

Clausing **Large Swing Lathes**

600 Group

*Built to Meet Your Turning Needs...
Extra Heavy-duty Large Swing, Big Bore,
Precision Gap Bed Standard Lathes*

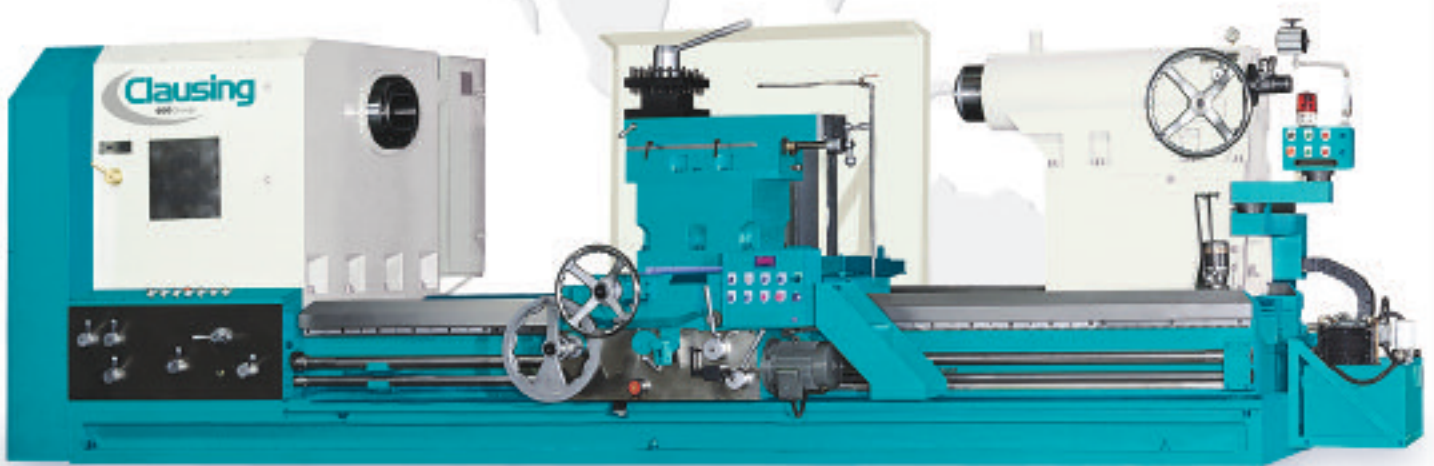

- **Swing Range... 34.6" to 100"**
- **Spindle Bore Range... 6" to 24"**
- **Center Distance Range... 63" to 487"**

Clausing Large Swing Heavy-Duty Gap Bed Standard Lathes are Built for all Your Turning Needs. Just fill out the “Clausing Large Swing Standard Lathe Profile” and we will design a machine that is ideal for Your turning applications. Larger custom designed machines available.

MA Series

Machining Range...

Capacity

- Swing over bed: 34.6" (880mm) 39.7" (1000mm) 44.6" (1135mm) 50" (1275mm)
- Swing over cross slide: 24" (610mm) 29" (740mm) 34.3" (870mm) 39.7" (1010mm)
- Swing in gap: 53" (1340mm) 57.9" (1470mm) 63" (1600mm) 68.5" (1740mm)
- Gap width from headstock: 23.6" (600mm)
- Center height over bed: 17.3" (400mm) 19.85" (505mm) 22.3" (568mm) 25" (638mm)
- Center height from floor: 44.1" (1120mm) 46.7" (1185mm) 49.1" (1248mm) 51.8" (1315mm)
- Center distance: 63" (1600mm) to 476" (12100mm) (see dimension & center distance chart)
- Maximum weight between centers: 8,800 lbs (4000kg)
- Maximum weight with steady rest: 11,000 lbs (5000kg)
- Maximum unsupported weight in chuck: 5,500 lbs (2500kg)
- Small closed steady rest (optional): 1.2" (30mm) to 15.7" (400mm)
- Large closed steady rest (optional): 13.8" (350mm) to 27.6" (700mm)
- Follower rest (optional): 1.5" (40mm) to 7" (178mm)

Bed

- Bed width: 22" (560mm) with standard auxiliary guides: 25.5" (650mm)
- Bed height from floor: 26.77" (680mm)
- 1.97" (50mm) leadscrew, leadscrew/feed rod support on
- 122" (3100mm) and longer models

Headstock

- Spindle bore 6" (153mm) standard,
- Up to 14.17" (360mm) optional on 34.6" (880mm) swing models
- Up to 16.14" (410mm) optional 39.7" (1010mm) and larger swing models
- Spindle nose: A2-11 to A2-28
- Spindle speed range: 18 step manual gear change on 6" (153mm) - 10.03" (255mm) spindle bore models, 4 range auto change variable speed with CSS on 12.5" (318mm) and larger spindle bore models (optional on 6" (153mm) - 10.03" (255mm) spindle bore models)
- Spindle speeds: 8-800 rpm 18 step manual gear box, 4-1000 rpm auto variable speed (see spindle and speed range chart)
- Spindle drive motor: 30 Hp standard

Carriage

- Cross-slide travel: 26.4" (670mm)
- Compound rest travel: 17.7" (450mm)
- 4 way, 8 position tool post with T-slots

Tailstock

- Quill diameter: 4.5" (115mm)
- Quill travel: 7.87" (200mm)
- Quill taper: 6MT
- Bearing surface on bed ways: 19.75" (500mm)
- Manual tailstock with saddle pin body movement

MB Series

Machining Range...

Capacity

- Swing over bed: 44.6" (1135mm) 50" (1275mm) 60" (1527mm) 70" (1790mm)
- Swing over cross slide: 31.9" (810mm) 37" (950mm) 47" (1200mm) 57" (1460mm)
- Swing in gap: 65" (1650mm) 70" (1780mm) 80" (2040mm) 90" (2300mm)
- Gap width from headstock: 23.6" (600mm)
- Center height over bed: 22.3" (568mm) 25" (638mm) 30" (764mm) 35" (895mm)
- Center height from floor: 49.1" (1246mm) 51.8" (1315mm) 56.8" (1442mm) 61.8" (2330mm)
- Center distance: 69" (1750mm) to 482" (12250mm) (see dimension & center distance chart)
- Maximum weight between centers: 11,000 lbs (5000kg)
- Maximum weight with steady rest: 13,200 lbs (6000kg)
- Maximum unsupported weight in chuck: 6,600 lbs (3000kg)
- Small closed steady rest (optional): 1.2" (30mm) to 15.75" (400mm)
- Large closed steady rest (optional): 13.8" (350mm) to 27.6" (700mm)
- Follower rest (optional): 1.5" (40mm) to 7" (178mm)

Bed

- Bed width: 28" (712mm) with standard auxiliary guides: 32" (812mm)
- Bed height from floor: 26.77" (680mm)
- 1.97" (50mm) leadscrew, leadscrew/feed rod support on
- 128" (3250mm) and longer models

Headstock

- Spindle bore: 6" (153mm) standard, up to 24.02" (610mm) optional
- Spindle nose: A2-11 to A2-28
- Spindle speed range: 18 step manual gear change on 6" (153mm) and 9" (230mm) spindle bore models, 4 range auto change variable speed with CSS on 10.03" (255mm) and larger spindle bore models (optional on 6" (153mm) and 9" (230mm) spindle bore models)
- Spindle speeds: 8-800 rpm 18 step manual gear box, 4-1000 rpm auto variable speed (see spindle and speed range chart)
- Spindle drive motor: 40 Hp standard

Carriage

- Cross-slide travel: 31.5" (800mm)
- Compound rest travel: 17.7" (450mm)
- 4 way, 8 position tool post with T-slots

Tailstock

- Quill diameter: 5.7" (145mm)
- Quill travel: 7.87" (200mm)
- Quill taper: 6MT
- Bearing surface on bed ways: 23.5" (600mm)
- Manual tailstock with saddle pin body movement

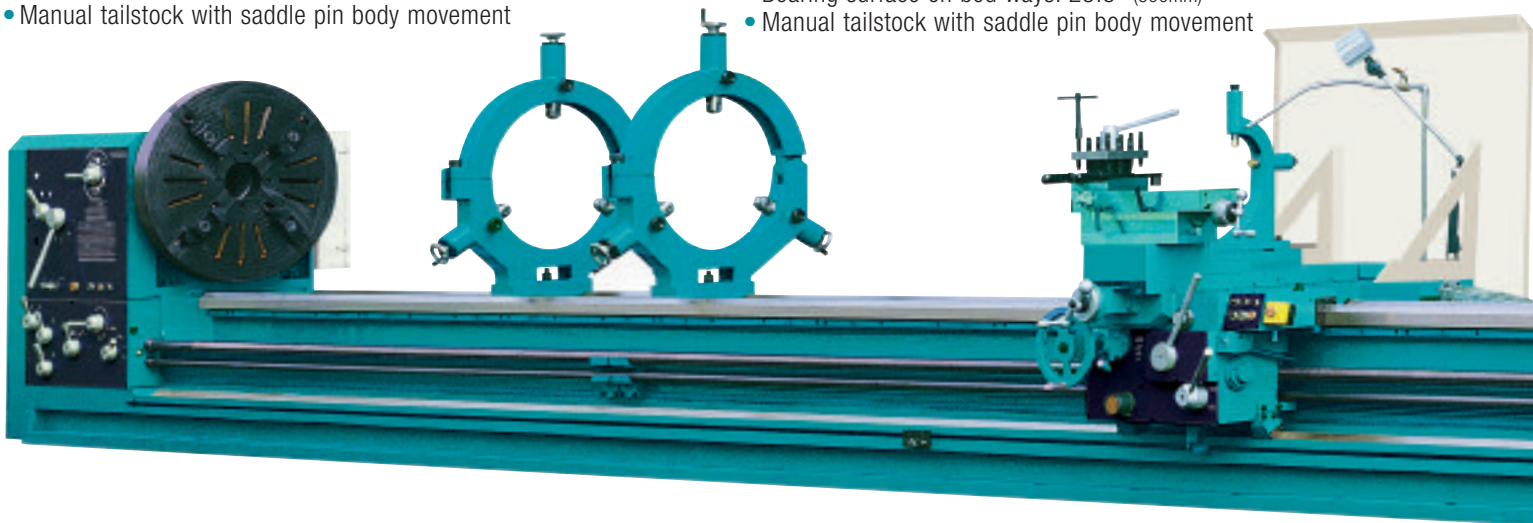

Shown with optional steady rests, follower rest and 4 jaw face plate

Due to on going design improvements or customer requirements, design and specifications are subject to change without notice.

Clousing Large Swing Lathes are designed for optimum performance, heavy stock removal while providing the versatility required by a large range of industries. All machines are tested to the most stringent accuracy and test cuts are made before shipping...

MH Series

Machining Range...

Capacity

- Swing over bed: 50" (1275mm) 60" (1527mm) 70" (1790mm) 80" (2040mm)
- Swing over cross slide: 35" (885mm) 44.7" (1137mm) 55" (1400mm) 65" (1650mm)
- Center height over bed: 25" (638mm) 30" (764mm) 35" (895mm) 40" (1020mm)
- Center height from floor: 54" (1372mm) 59" (1500mm) 64" (1625mm) 69" (1752mm)
- Center distance: 93" (2370mm) to 487" (12370mm)
(see dimension & center distance chart)
- Maximum weight between centers: 17,600 lbs (8000kg)
- Maximum weight with steady rest: 22,200 lbs (10000kg)
- Maximum unsupported weight in chuck: 9,900 lbs (4500kg)
- Small closed steady rest (optional): 1.2" (30mm) to 15.75" (400mm)
- Small open steady rest (optional): 1.2" (30mm) to 15.75" (400mm)
- Large closed steady rest (optional): 13.8" (350mm) to 27.56" (700mm)
- Large open steady rest (optional): 13.8" (350mm) to 27.56" (700mm)

Bed

- Bed width: 40" (1020mm), with standard auxiliary guides: 45.7" (1160mm)
- Bed height from floor: 29" (740mm)
- 1.97" (50mm) leadscrew, leadscrew/feed rod support on 132" (3352mm) and longer models

Headstock

- Spindle bore: 6" (153mm) standard, up to 24.02" (610mm) optional
- Spindle nose: A2-11 to A2-28
- Spindle speed range: 4 auto change variable speed ranges with CSS
- 4-1000 rpm auto variable speed (see spindle and speed range chart)
- Spindle drive motor: 50 Hp standard

Carriage

- Cross-slide travel: 43.3" (1100mm)
- Compound rest travel: 17.7" (450mm)
- 4 way, 8 position tool post with T-slots

Tailstock

- Quill diameter: 9.25" (235mm)
- Quill travel: 7.87" (200mm)
- Quill taper: 6MT
- Bearing surface on bed ways: 26" (660mm)
- Hydraulic tailstock with rotating quill and hydraulic body movement

MK Series

Machining Range...

Capacity

- Swing over bed: 70" (1790mm) 80" (2040mm) 90" (2290mm) 100" (2540mm)
- Swing over cross slide: 53" (1350mm) 63" (1590mm) 73" (1840mm) 82" (2090mm)
- Center height over bed: 35" (895mm) 40" (1020mm) 45" (1145mm) 50" (1270mm)
- Center height from floor: 49" (1245mm) 52" (1320mm) 58" (1475mm) 62" (1575mm)
- Center distance: 81" (2060mm) to 474" (12060mm)
(see dimension & center distance chart)
- Maximum weight between centers: 33,000 lbs (15000kg)
- Maximum weight with steady rest: 37,400 lbs (17000kg)
- Maximum unsupported weight in chuck: 19,800 lbs (900kg)
- Small closed steady rest (optional): 1.2" (30mm) to 15.75" (400mm)
- Small open steady rest (optional): 1.2" (30mm) to 15.75" (400mm)
- Large closed steady rest (optional): 13.8" (350mm) to 27.56" (700mm)
- Large open steady rest (optional): 13.8" (350mm) to 27.56" (700mm)
- Extra large closed steady rest (optional): 26.6" (675mm) to 39.4" (1000mm)
- Extra large closed steady rest (optional): 26.6" (675mm) to 39.4" (1000mm)

Bed

- Bed width: 47.5" (1210mm), with standard auxiliary guides: 54" (1370mm)
- Bed height from floor: 30" (760mm)
- 2.36" (60mm) leadscrew, leadscrew/feed rod support on 120" (3048mm) and longer models

Headstock

- Spindle bore: 9" (230mm) standard, up to 24.02" (610mm) optional
- Spindle nose: A2-15 to A2-28
- Spindle speed range: 4 auto change variable speed ranges with CSS
- 4-700 rpm auto variable speed (see spindle and speed range chart)
- Spindle drive motor: 75 Hp standard

Carriage

- Cross-slide travel: 51" (1300mm)
- Compound rest travel: 19.7" (500mm)
- 4 way, 12 position tool post with T-slots

Tailstock

- Quill diameter: 11" (280mm)
- Quill travel: 10" (250mm)
- Quill taper: 6MT
- Bearing surface on bed ways: 44" (1120mm)
- Hydraulic tailstock with rotating quill and hydraulic body movement

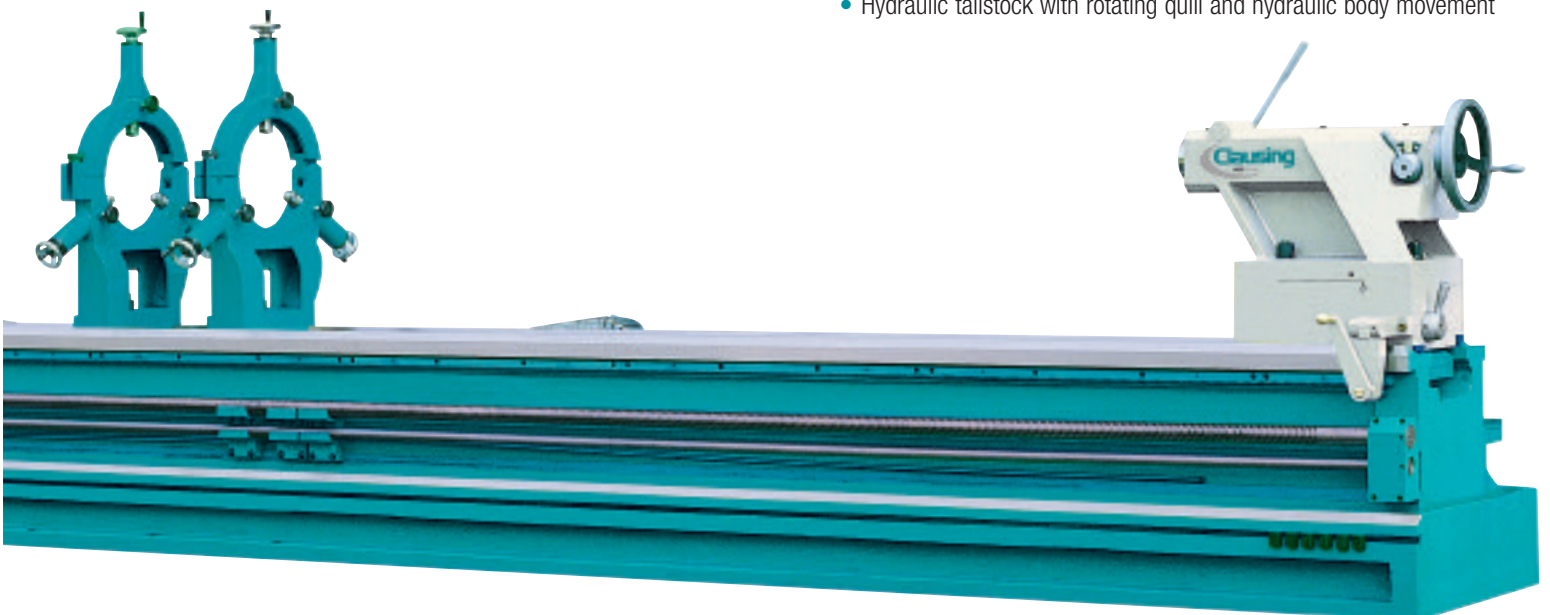

Center Distance, Dimensions and Weight

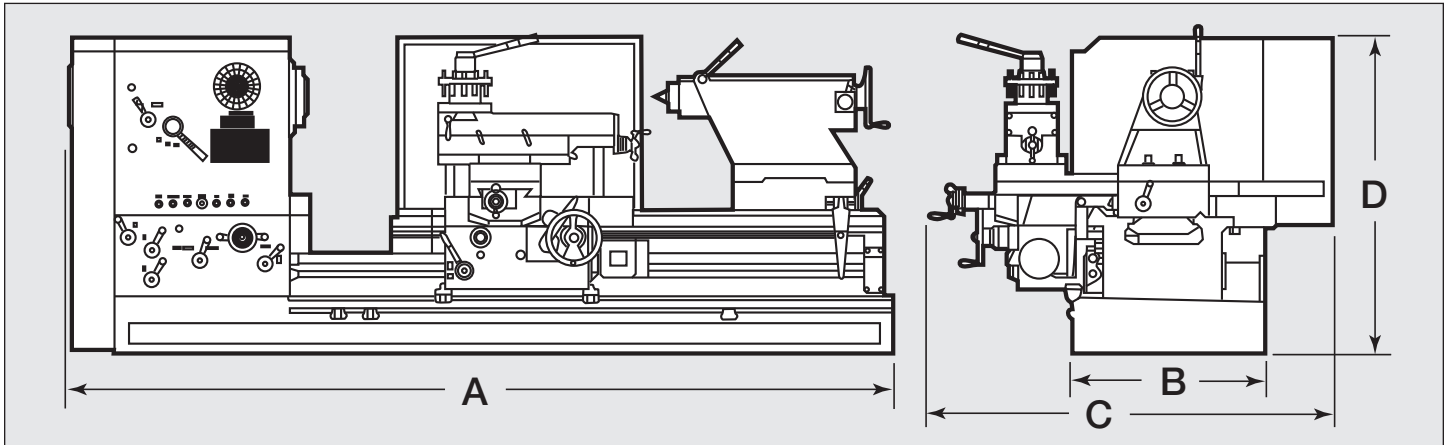

MA Series

Center Distance	63" (1600mm)	82" (2100mm)	122" (3100mm)	160" (4100mm)	200" (5100mm)	240" (6100mm)	279" (7100mm)	318" (8100mm)	358" (9100mm)	397" (10100mm)	437" (11100mm)	476" (12100mm)
Length A	145" (3690mm)	165" (4190mm)	204" (5190mm)	244" (6190mm)	283" (7180mm)	322" (8190mm)	362" (9190mm)	401" (10901mm)	440" (11190mm)	480" (12190mm)	519" (13190mm)	559" (14190mm)
Base width B	34.6" (880mm)											
Overall width C	71" (1800mm)											
Height D	35" (880mm) swing - 54" (1370mm)			40" (1010mm) swing - 56" (1422mm)			45" swing (1135mm) - 59" (1500mm)			50" swing (1275mm) - 62" (1575mm)		
Weight lbs.(kg)												
35" swing	20,900 (9480)	22,000 (9980)	24,200 (10980)	26,400 (11975)	28,600 (12975)	30,800 (13970)	33,000 (14970)	35,200 (15970)	37,400 (16965)	39,600 (17965)	41,800 (18960)	44,000 (19960)
40" swing	21,670 (9830)	22,770 (10330)	24,970 (11330)	27,170 (12325)	29,370 (13325)	31,570 (14320)	33,770 (15320)	35,970 (16315)	38,170 (17315)	40,370 (18405)	42,570 (19310)	44,770 (20310)
45" swing	22,440 (10180)	23,540 (10675)	25,740 (11675)	27,940 (12675)	30,140 (13675)	32,340 (14670)	34,540 (15670)	36,740 (16665)	38,940 (17665)	41,140 (18665)	43,340 (19660)	45,540 (20660)
50" swing	23,440 (10635)	24,310 (11027)	26,510 (12025)	28,710 (13025)	30,910 (14020)	33,110 (15020)	35,310 (16065)	37,510 (17015)	39,710 (18015)	41,910 (19010)	44,110 (20010)	46,310 (21010)

MB Series

Center Distance	69" (1750mm)	88" (2550mm)	128" (3250mm)	167" (4250mm)	206" (5250mm)	246" (6250mm)	285" (7250mm)	324" (8250mm)	364" (9250mm)	403" (10250mm)	443" (11250mm)	482" (12250mm)
Length A	158" (4010mm)	178" (4510mm)	217" (5510mm)	256" (6510mm)	296" (7510mm)	335" (8510mm)	374" (9510mm)	414" (10510mm)	453" (11510mm)	493" (12510mm)	532" (13510mm)	571" (14510mm)
Base width B	37.4" (950mm)											
Overall width C	78" (1990mm)											
Height D	45" (1135mm) swing - 62" (1550mm)			50" (1275mm) swing - 64" (1625mm)			60" (1527mm) swing - 69" (1757mm)			70" (1790mm) swing - 74" (1880mm)		
Weight lbs.(kg)												
45" swing	27,280 (12375)	29,040 (13175)	32,560 (14770)	36,080 (16365)	39,600 (17965)	43,120 (19560)	46,640 (21155)	50,160 (22755)	53,680 (24350)	57,200 (25945)	60,720 (27545)	64,240 (29140)
50" swing	28,160 (12775)	29,920 (13575)	33,440 (15170)	36,960 (16765)	40,480 (18365)	44,000 (19960)	47,520 (21555)	51,040 (23155)	54,560 (24750)	58,080 (26345)	61,600 (27945)	65,120 (29540)
60" swing	30,100 (13655)	31,680 (14370)	35,200 (15970)	38,720 (17365)	42,240 (19160)	45,760 (20760)	49,280 (22355)	52,800 (23950)	56,320 (25560)	59,840 (27145)	63,360 (28740)	66,880 (30340)
70" swing	31,680 (14370)	33,440 (15170)	36,960 (16765)	40,480 (18365)	44,000 (19960)	47,520 (21555)	51,040 (23155)	54,560 (24750)	58,080 (26345)	61,600 (27945)	65,120 (29540)	68,640 (31135)

Due to on going design improvements or customer requirements, design and specifications are subject to change without notice.

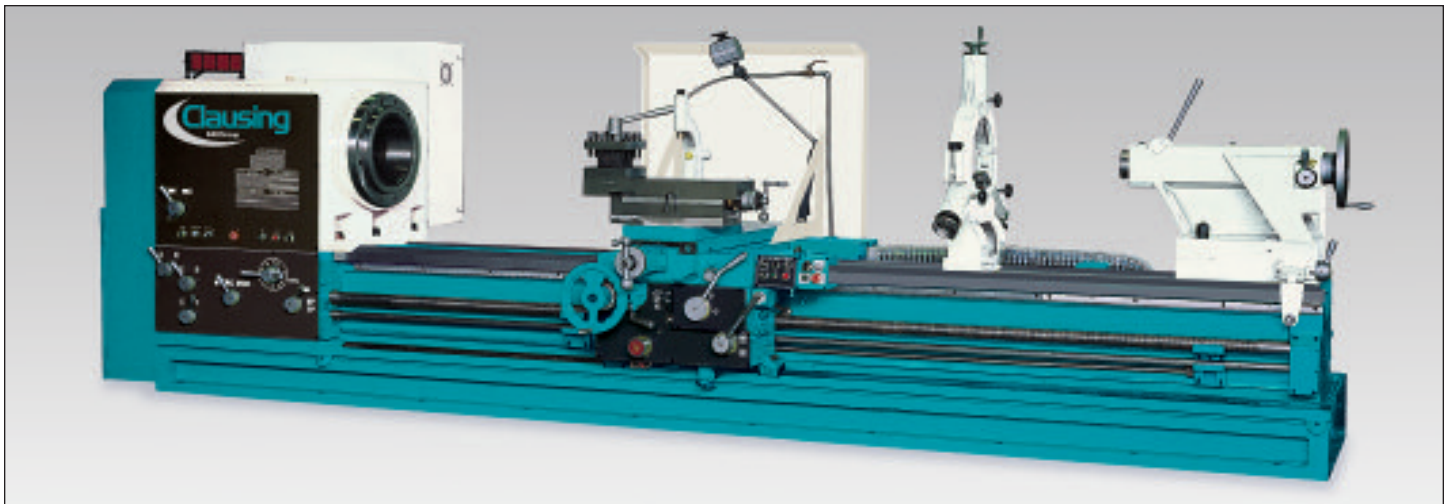

Center Distance, Dimensions and Weight

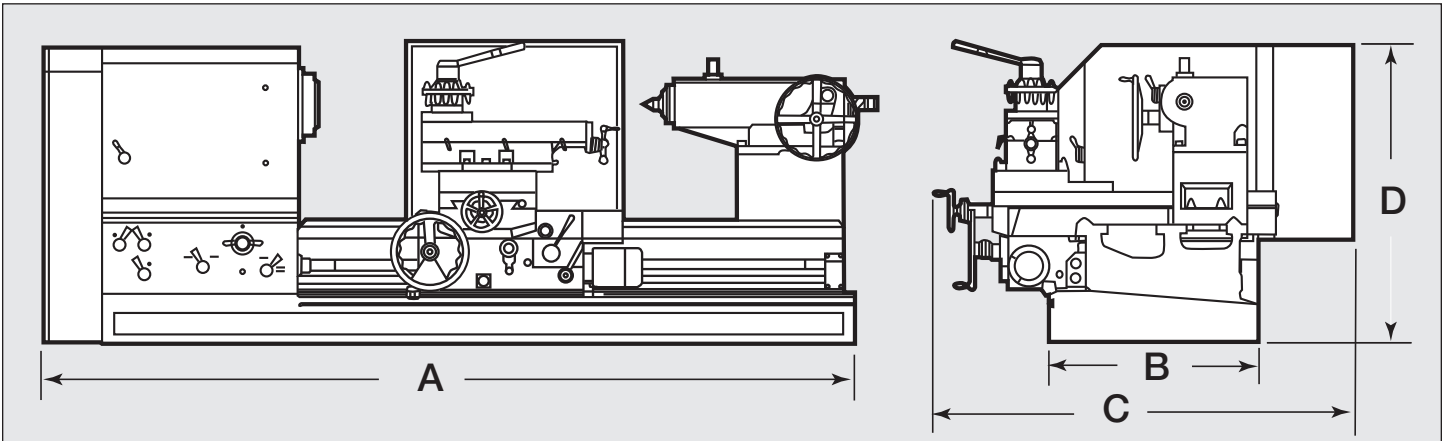

MH Series

Center Distance	93" (2370mm)	132" (3370mm)	172" (4370mm)	210" (5370mm)	250" (6370mm)	290" (7370mm)	329" (8370mm)	368" (9370mm)	408" (10370mm)	447" (11370mm)	487" (12370mm)
Length A	215" (5450mm)	254" (6450mm)	293" (7450mm)	333" (8450mm)	372" (9450mm)	411" (10450mm)	451" (11450mm)	490" (12450mm)	529" (13450mm)	569" (14450mm)	608" (15450mm)
Base width B	49.6" (1290mm)										
Overall width C	105" (2660mm)										
Height D	50" swing (1275mm) - 72" (1830mm)			60" (1527mm) swing - 77" (1955mm)			70" (1790mm) swing - 83" (2110mm)		80" (2040mm) swing - 88" (2235mm)		
Weight lbs.(kg)											
50" swing	36,740 (16665)	42,240 (19160)	47,740 (21655)	53,240 (24150)	58,740 (26645)	64,240 (29140)	69,740 (31635)	75,240 (34130)	80,740 (36625)	86,240 (39120)	91,740 (41620)
60" swing	38,940 (17665)	44,440 (20160)	49,940 (22655)	55,440 (25150)	60,940 (27645)	66,440 (30137)	71,940 (32635)	77,440 (35130)	82,940 (37625)	88,440 (40120)	93,940 (42615)
70" swing	41,140 (18665)	46,640 (21155)	52,140 (23650)	57,640 (26145)	63,140 (28640)	68,640 (31135)	74,140 (33630)	79,640 (36125)	85,140 (38620)	90,640 (41115)	96,140 (43610)
80" swing	43,340 (19660)	48,840 (22155)	54,340 (24650)	59,840 (27145)	65,340 (29640)	70,840 (32135)	76,340 (34630)	81,840 (37125)	87,340 (39620)	92,840 (42115)	98,340 (44610)

MK Series

Center Distance	81" (2060mm)	120" (3060mm)	160" (4060mm)	199" (5060mm)	238" (6060mm)	278" (7060mm)	317" (8060mm)	356" (9060mm)	396" (10060mm)	435" (12060mm)	474" (13060mm)
Length A	215" (5450mm)	254" (6450mm)	293" (7450mm)	333" (8450mm)	372" (9450mm)	411" (10450mm)	451" (11450mm)	490" (12450mm)	529" (13450mm)	569" (14450mm)	608" (15450mm)
Base width B	57.9" (1470mm)										
Overall width C	101" (2815mm)										
Height D	70" (1790mm) swing - 78" (1980mm)		80" (2040mm) swing - 83" (2110mm)			90" swing (2290mm) - 88" (2235mm)		100" (2540mm) swing - 94" (2390mm)			
Weight lbs.(kg)											
70" swing	49,940 (22655)	58,740 (26645)	67,540 (30640)	76,340 (34630)	85,140 (38620)	93,940 (42615)	102,740 (46605)	111,540 (50595)	120,340 (54590)	129,140 (58575)	137,940 (62210)
80" swing	53,240 (24150)	62,040 (28145)	70,840 (32135)	79,640 (36125)	88,440 (40120)	97,240 (44110)	106,040 (48100)	114,840 (52095)	123,640 (56085)	132,440 (60075)	141,240 (64070)
90" swing	56,540 (25650)	65,340 (29640)	74,140 (33630)	82,940 (37625)	91,740 (41615)	100,540 (45605)	109,340 (49595)	118,140 (53590)	126,940 (57580)	135,740 (61575)	144,540 (65565)
100" swing	59,840 (27145)	68,640 (31135)	77,440 (35130)	86,240 (39120)	95,040 (43110)	103,840 (47105)	112,670 (51185)	121,440 (55190)	130,240 (59080)	139,040 (63070)	147,840 (67060)

Due to on going design improvements or customer requirements, design and specifications are subject to change without notice.

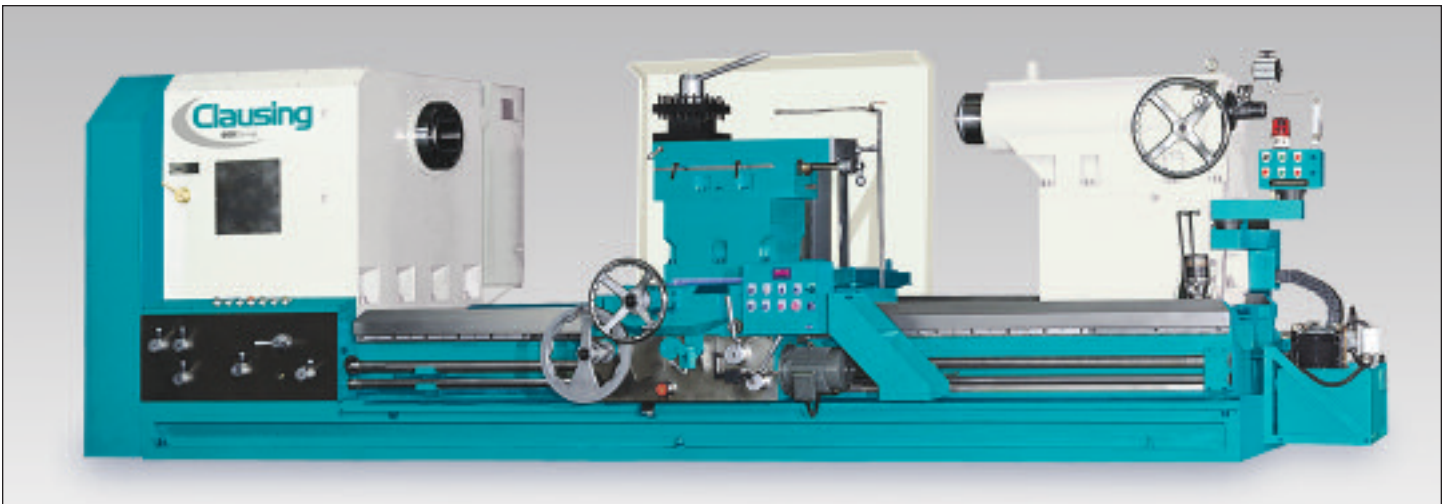

Clausing Manual Large Swing Lathes Standard Equipment

MA Series

- Chuck guard with limit switch
- 30 Hp spindle drive motor
- Auto power off with 2 adjustable position stops
- Mechanical safety device • Lockable main switch
- Electrical cabinet ventilation fans • Electromagnetic spindle brake
- 6 way rapid traverse • 6 way power feed
- 4 way 8 position tool post with T-slots • 2 dead centers
- Steel leadscrew cover • Coolant system • Auto lube
- Thread dial • QIK Threading system and A.P.I. threads
- Manual tailstock with saddle pin body movement and anti slip lock
- Gears and bed ways hardened and ground
- Traveling splash guard • Built-in air power supply tube
- Halogen work light
- Leveling screws and pads
- Tools, tool box and operation manual

MB Series

- Chuck guard with limit switch
- 40 Hp spindle drive motor
- Auto power off with 2 adjustable position stops
- Mechanical safety device • Lockable main switch
- Electrical cabinet ventilation fans • Electromagnetic spindle brake
- 6 way rapid traverse • 6 way power feed
- 4 way 8 position tool post with T-slots • 2 dead centers
- Steel leadscrew cover • Coolant system • Auto lube
- Thread dial • QIK Threading system and A.P.I. threads
- Manual tailstock with saddle pin body movement and anti slip lock
- Gears and bed ways hardened and ground
- Traveling splash guard • Built-in air power supply tube
- Halogen work light
- Leveling screws and pads
- Tools, tool box and operation manual

MH Series

- Chuck guard with limit switch
- 50 Hp motor with inverter variable speed motor
- 4 range auto change variable speed with CSS
- Auto power off with 2 adjustable position stops
- Mechanical safety device • Lockable main switch
- Electrical cabinet ventilation fans • Electromagnetic spindle brake
- 6 way rapid traverse
- 6 way power feed
- 4 way 8 position tool post with T-slots • 2 dead centers
- Steel leadscrew cover • Coolant system • Auto lube
- Thread dial • QIK Threading system and A.P.I. threads
- Hydraulic tailstock with with rotating quill, hydraulic movement and anti-slip lock
- Gears and bed ways hardened and ground
- Traveling splash guard
- Built-in air power supply tube
- Halogen work light
- Leveling screws and pads
- Tools, tool box and operation manual

MK Series

- Chuck guard with limit switch
- 75 Hp motor with inverter variable speed motor
- 4 range auto change variable speed with CSS
- Auto power off with 2 adjustable position stops
- Mechanical safety device • Lockable main switch
- Electrical cabinet ventilation fans • Electromagnetic spindle brake
- 6 way rapid traverse
- 6 way power feed
- 4 way 12 position tool post with T-slots • 2 dead centers
- Steel leadscrew cover • Coolant system • Auto lube
- Thread dial • QIK Threading system and A.P.I. threads
- Hydraulic tailstock with with rotating quill, hydraulic movement and anti-slip lock
- Gears and bed ways hardened and ground
- Traveling splash guard
- Built-in air power supply tube
- Halogen work light
- Leveling screws and pads
- Tools, tool box and operation manual

Thread and feed Range Spindle Bore and Speed Range

Longitudinal feeds	0.0018-0.1in/rev (0.045-2.55mm/rev)
Cross feeds	0.0009-0.05(in/rev) (0.023-1.28mm/rev)
Longitudinal rapid feeds	80in/min (2000mm/min)
Cross rapid feeds	40in/min (2000mm/min)
No. of metric threads	60
Range (mm)	1-56
No. of inch threads	60
Range (tpi)	1/2-28
No. of module threads	60
Range (mod)	0.25-14
No. of diametral pitch threads	60
Range (mm)	2-112
Leadscrew pitch (tpi)	2

Spindle Bore Size	6.02" (153mm)	9.05" (230mm)	10.03" (255mm)	12.5318" (153mm)	14.17" (360mm)	16.14" (410mm)	21.06" (535mm)	24.02" (610mm)
Spindle Nose	A2-11	A2-15	A2-15	A2-20	A2-20	A2-28	A2-28	A2-32
Front Spindle Bearing	7.87" (200mm)	12" (305mm)	14" (355mm)	15" (381mm)	16.12" (409mm)	19.25" (489mm)	23.5" (596mm)	27.5" (698mm)
Speed Range #1 (rpm)	18-130	16-120	13-95	12-85	10-75	8-50	6-40	4-25
Speed Range #2 (rpm)	35-260	30-200	25-185	23-170	20-150	15-100	12-80	8-50
Speed Range #3 (rpm)	85-550	70-420	60-400	55-300	50-250	35-200	30-180	20-140
Speed Range #4 (rpm)	165-1000	150-700	120-600	110-400	95-350	65-300	50-250	40-220
18 Step Gear Box								
Spindle Speeds (rpm)	8-11-15-19-25-35-50-68-87-100-120-145-215-320-410-480-620-800							
*Optional 1000 (rpm)	10-15-19-25-31-43-65-85-105-130-150-180-270-400-500-590-780-1000							
*Optional 1200 (rpm)	12-17-23-30-38-52-78-105-130-155-180-215-325-480-610-700-930-1200							

*Optional 1000 and 1200 rpm 18 step gear box require refrigerated electrical cabinet.

Due to on going design improvements or customer requirements, design and specifications are subject to change without notice.

Optional Equipment

MA Series

- 'CE' Telemecanique electrics
- 40 hp spindle drive motor
- Spindle bore up to 14.17" on 34.6" swing and 16.14" on 39.7" swing and larger
- 4 range auto change variable speed with CSS for 6"/9"/10" bore models
- Dual chuck adapter
- Closed steady rest 1.5" to 15.75"
- Closed steady rest 13.8" to 27.56"
- Follower rest 1.5" to 7"
- Full length rear splash guard
- Full guarding
- Belt chip conveyor with cart
- 30" 4 jaw american type, ground, thick body chuck
- 36" 4 jaw american type, ground, thick body chuck
- 40" 4 jaw english type chuck
- 45" 4 jaw english type chuck
- 50" 4 jaw english type chuck
- Special long jaws
- Taper attachment
- Full length hydraulic profile cutting system including semi-auto threading
- Full length tracer
- Semi-auto threading • Micro stop

MB Series

- 'CE' Telemecanique electrics
- 50 hp spindle drive motor
- Spindle bore up to 24.02"
- 4 range auto change variable speed with CSS for 6"/9"/10" bore models
- Dual chuck adapter
- Closed steady rest 1.5" to 15.75"
- Closed steady rest 13.8" to 27.56"
- Follower rest 1.5" to 7"
- Full length rear splash guard
- Full guarding
- Belt chip conveyor with cart
- 30" 4 jaw american type, ground, thick body chuck
- 36" 4 jaw american type, ground, thick body chuck
- 40" 4 jaw english type chuck
- 45" 4 jaw english type chuck
- 50" 4 jaw english type chuck
- Special long jaws
- Taper attachment
- Full length hydraulic profile cutting system including semi-auto threading
- Full length tracer
- Semi-auto threading • Micro stop

MH Series

- 'CE' Telemecanique electrics
- 75 hp spindle drive motor
- Spindle bore up to 24.02"
- Dual chuck adapter
- Closed steady rest 1.5" to 15.75"
- Closed steady rest 13.8" to 27.56"
- Open steady rest 1.5" to 15.75"
- Open steady rest 13.8" to 27.56"
- Full length rear splash guard • Full guarding
- Belt chip conveyor with cart
- 40" 4 jaw ground, thick steel body chuck - A2-15
- 46" 4 jaw ground, thick steel body chuck - A2-15 to A2-28
- 50" 4 jaw ground, thick steel body chuck - A2-15 to A2-28
- 60" 4 jaw ground, thick steel body chuck - A2-15 to A2-28
- 70" 4 jaw ground, thick steel body chuck - A2-15 to A2-28
- 80" 4 jaw ground, thick steel body chuck - A2-15 to A2-28
- 30" 4 jaw american type, ground, thick body chuck
- 36" 4 jaw american type, ground, thick body chuck
- 40" 4 jaw english type chuck
- 45" 4 jaw english type chuck
- 50" 4 jaw english type chuck
- Special long jaws
- Taper attachment
- Full length hydraulic profile cutting system including semi-auto threading
- Full length tracer
- Semi-auto threading • Micro stop

MK Series

- 'CE' Telemecanique electrics
- 100 hp spindle drive motor
- Spindle bore up to 24.02"
- Dual chuck adapter
- Closed steady rest 1.5" to 15.75" • Closed steady rest 13.8" to 27.56"
- Closed steady rest 23.6" to 39.37"
- Open steady rest 1.5" to 15.75" • Open steady rest 13.8" to 27.56"
- Open steady rest 23.6" to 39.37"
- Full length rear splash guard • Full guarding
- Belt chip conveyor with cart
- 40" 4 jaw ground, thick steel body chuck - A2-15
- 46" 4 jaw ground, thick steel body chuck - A2-15 to A2-28
- 50" 4 jaw ground, thick steel body chuck - A2-15 to A2-28
- 60" 4 jaw ground, thick steel body chuck - A2-15 to A2-28
- 70" 4 jaw ground, thick steel body chuck - A2-15 to A2-28
- 80" 4 jaw ground, thick steel body chuck - A2-15 to A2-28
- 50" 4 jaw english type chuck - A2-15 to A2-28
- 55" 4 jaw english type chuck - A2-15 to A2-28
- 60" 4 jaw english type chuck - A2-15 to A2-28
- 70" 4 jaw english type chuck - A2-15 to A2-28
- 80" 4 jaw english type chuck - A2-15 to A2-28
- 90" 4 jaw english type chuck - A2-15 to A2-28
- 100" 4 jaw english type chuck - A2-15 to A2-28
- Special long jaws • Taper attachment
- Full length hydraulic profile cutting system including semi-auto threading
- Full length tracer • Semi-auto threading • Micro stop

Due to on going design improvements or customer requirements, design and specifications are subject to change without notice.

The "Clousing Large Swing Standard Lathe Profile" e-form is available on our web site, simply save it to your desktop, fill it out and e-mail to: info@clousing-industrial.com

www.clousing-industrial.com



Your Single Source for Machine Tools

Clausing Precision Drills

- Clausing Belt-drive Drills
- Clausing Geared-head Drills
- Clausing Radial Drills

Clausing Precision Mills

- Clausing Bed Mills
- Clausing CNC Bed Mills
- Clausing Knee Mills
- Clausing EVS Knee Mills

Clausing Precision Lathes

- Clausing/Colchester Geared Head Lathes
- Clausing/Colchester Professional V.S. Lathes
- Clausing CV Standard and CNC Lathes
- Clausing Large Swing Standard and CNC Lathes

Clausing Precision Grinders

- Clausing Manual Grinders
- Clausing 2 Axes Hydraulic Grinders
- Clausing 3 Axes Hydraulic Grinders
- Clausing ASDII Automatic Grinders

Clausing Precision Cutting Machines

- Clausing Horizontal Bandsaws
- Clausing Vertical Bandsaws
- Clausing Tilt Frame Miter Bandsaws
- Clausing Cold Saws

For detailed catalogs of the full line of Clausing Machine Tools visit our Web Site:

www.clausing-industrial.com

or e-mail us and request an electronic (pdf) catalog at:

info@clausing-industrial.com

Your Authorized Clausing Precision Machine Tools Distributor



Clausing Industrial, Inc.
1819 North Pitcher Street
Kalamazoo, Michigan 49007-1886
Information: info@clausing-industrial.com

Toll Free: 800-323-0972
Phone: 269-345-7155
Fax: 269-345-5945
Web Site: www.clausing-industrial.com