



AHB
TOOLING & MACHINERY

COMPLETE METALWORKING SOLUTIONS
(800) 991-4225 www.ahbinc.com
ISO Certified customerservice@ahbinc.com



MD4



Universal working center for deburring and finishing ferrous and non ferrous materials. These machines are available with variable height, working width of 1150mm, and can process heavy parts of weight up to 300 Kg.

The machine utilizes 2200mm long sanding belts.

Thanks to our modular concept, it is possible to build a custom "working center" by inserting the proper working units required for each application.

The frame is engineered to hold 2-3 internal working units and one auxiliary unit.

Dimensions	A [mm]	B [mm]	C [mm]
2 working units	1660	1824	2070
3 working units	1921	1824	2070

MD5

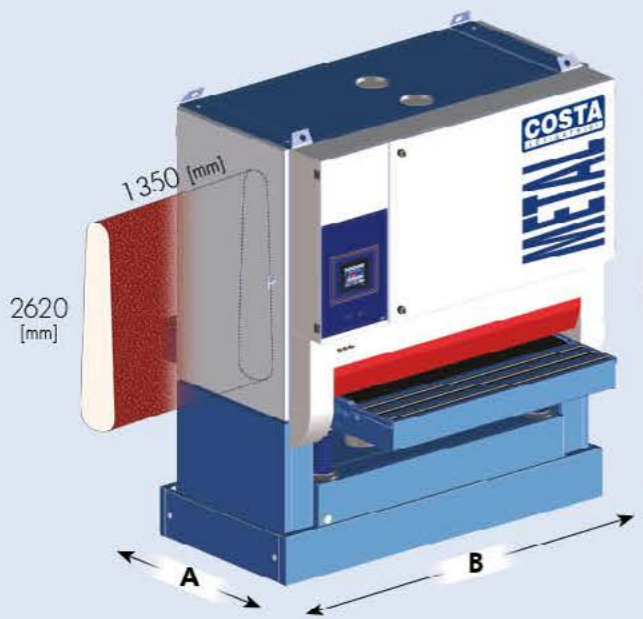

Universal working center for deburring and finishing ferrous and non ferrous materials. These machines are available with constant feed height for in-line operation, and to simplify the processing of large parts. They are available with a working width of 1350mm and can process parts of weight up to 400 Kg.

The machines utilize 2620mm longitudinal abrasive belts that guarantee longer life and a consistent finishing, reducing the consumable costs.

Thanks to our modular concept it is possible to build a custom "working center" by inserting the proper working units required for each application.

The frame is engineered to hold 2-3 internal working units and one auxiliary unit.

The high rigidity of the frame and feed table of this machine - combined with the advanced mechanics and electronic features - make of this series an universal working center for deburring and finishing.

Dimensions	A [mm]	B [mm]	C [mm]
2 working units	1864	2020	2305+2455
3 working units	2204	2020	2305+2455

MD61

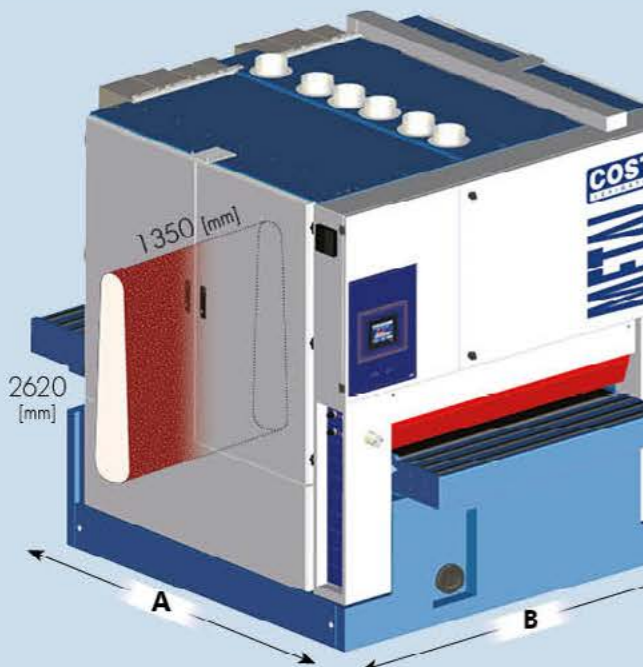

Universal working center for deburring and finishing ferrous and non ferrous materials. These machines are available with constant feed height for in-line operation, and to simplify the processing of large parts. They are available with a working width of 1350mm and can process parts of weight up to 500 Kg.

The machines utilizes 2620mm longitudinal abrasive belts that guarantee longer life and a consistent finishing, reducing the consumable costs.

Thanks to our modular concept it is possible to build a custom "working center" by inserting the proper working units required for each application.

The frame is engineered to hold 4 internal working units and one auxiliary unit.

Dimensions	A [mm]	B [mm]	C [mm]
4 working units	2925	2140	2215+2375

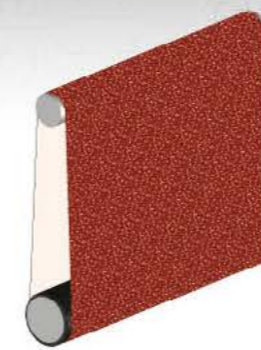

Cylinder (Ø 200mm / Ø 330mm)

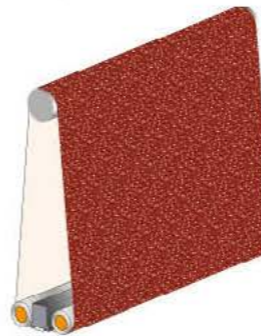

Pad



Top vertical brush (Ø 85mm / Ø 130mm)



Orbital multi-brushes



Longitudinal Brush Ø 180 (Stainless steel, Scotch-Brite™..)

MD4
(2 / 3 units) **MD5**
(2 / 3 units) **MD61**
(4 units)

Grinding



Deburring



Finishing



Vacuum hold plant (standard from dust system - optional with electroventilator)

The vacuum hold system improves holding of small and/or slippery work-pieces to the feed belt. It is connected to the dust extraction plant (a good air speed is required).

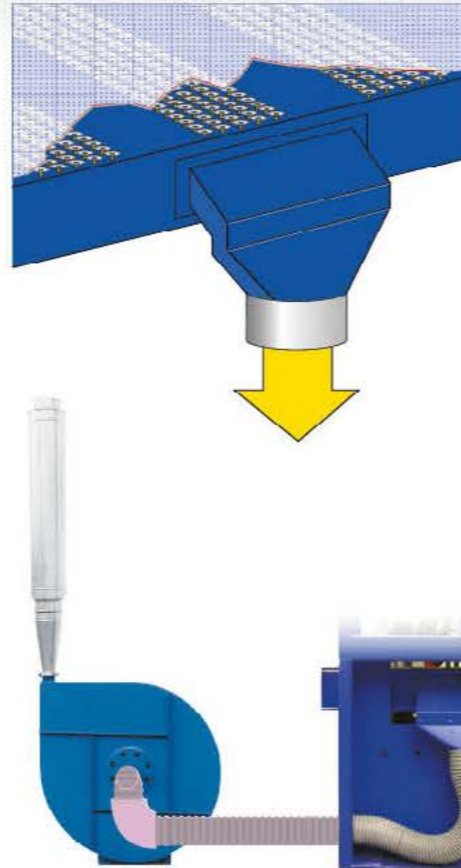
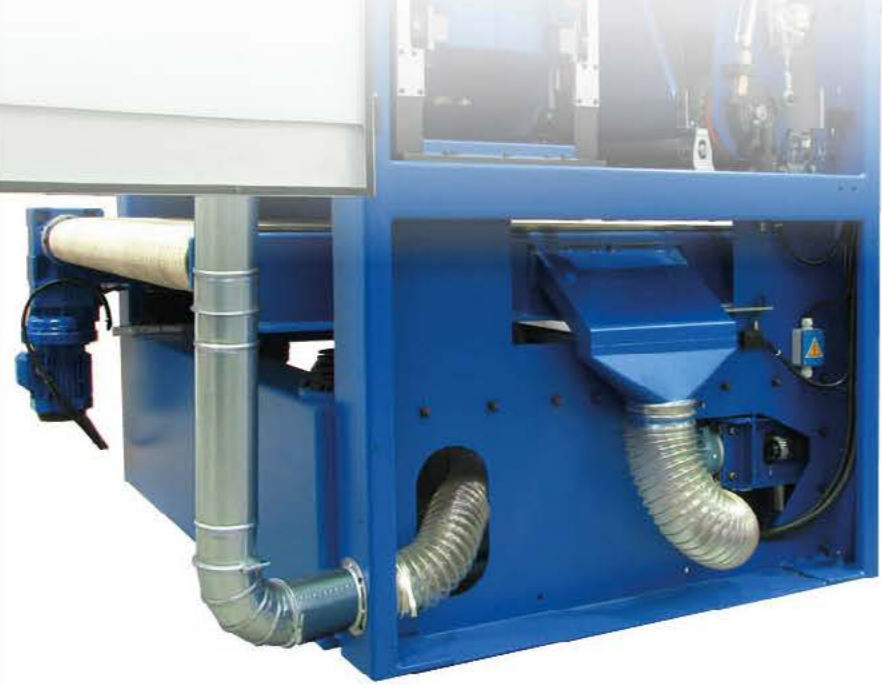

A high speed electroventilator creates a vacuum hold under each working unit to secure the traction of slippery material or of workpieces smaller than distance between the pressure units (opt.)

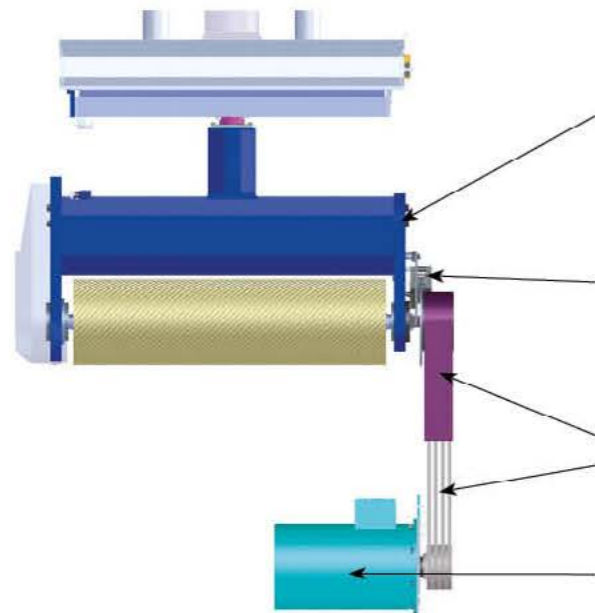

Heavy-duty rigid supporting beam to sustain the working units and the sanding belt tensioning system. The working units are adjustable from right to left to maintain the parallelism with the feed table.

Disk brakes with pneumatic clamps. They are equipped with non ferrous brake pads to avoid sparks.

Transmission with:
 • "Poly V" belt system (optional), with double pneumatic tensioning system;
 • "V" belt system (standard) with mechanical / pneumatic tensioning system.

Motors are positioned inside machine frame.

Safety in-feed sensing roller for over thickness limit

Safety device designed to stop the feed and exclude all the working units if the roller detects a work-piece thickness exceeding the programmed value.

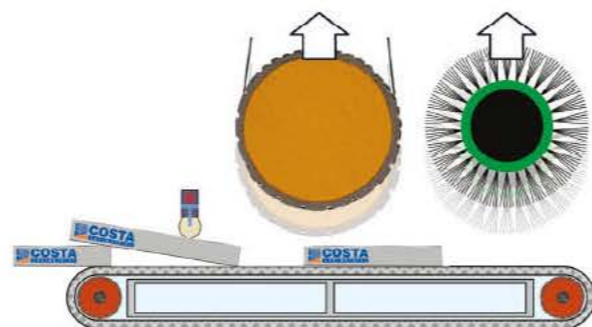

PLC VISION (optional)

The PLC panel VISION enables the visualization in a touch-screen monitor of the actual setup data and operation of the machine and to store many complete working programmes.



Power Saving Features

The power saving features (standard), allow the use of the machine with maximum efficiency in respect of the environment.

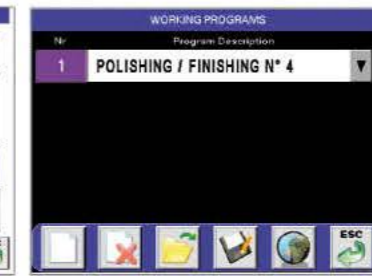
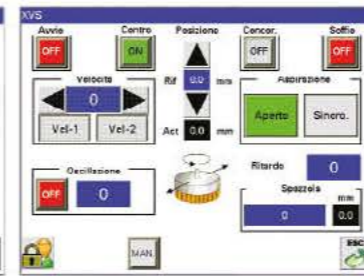
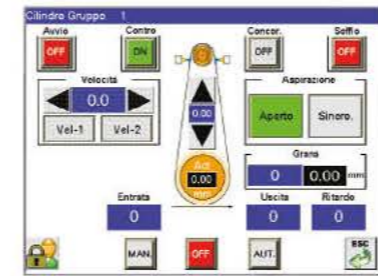

Wireless caliper (optional)

Automatic thickness setting by means of Electronic Wireless Caliper; using this Caliper, the operator will be able to measure the work pieces being processed and send the information to the PLC VISION just with a simple click.



Electromechanical panel (standard)

Control panel positioned in front of the machine, with push-buttons for all motors and ammeter readers of power utilization of the working units. Emergency stop and reset. Range change switch for the variation of the feed speed. Diagnostic leds of electric-pneumatic / safety problems.



Digital positioner with read-out of the thickness adjustment with decimal accuracy.

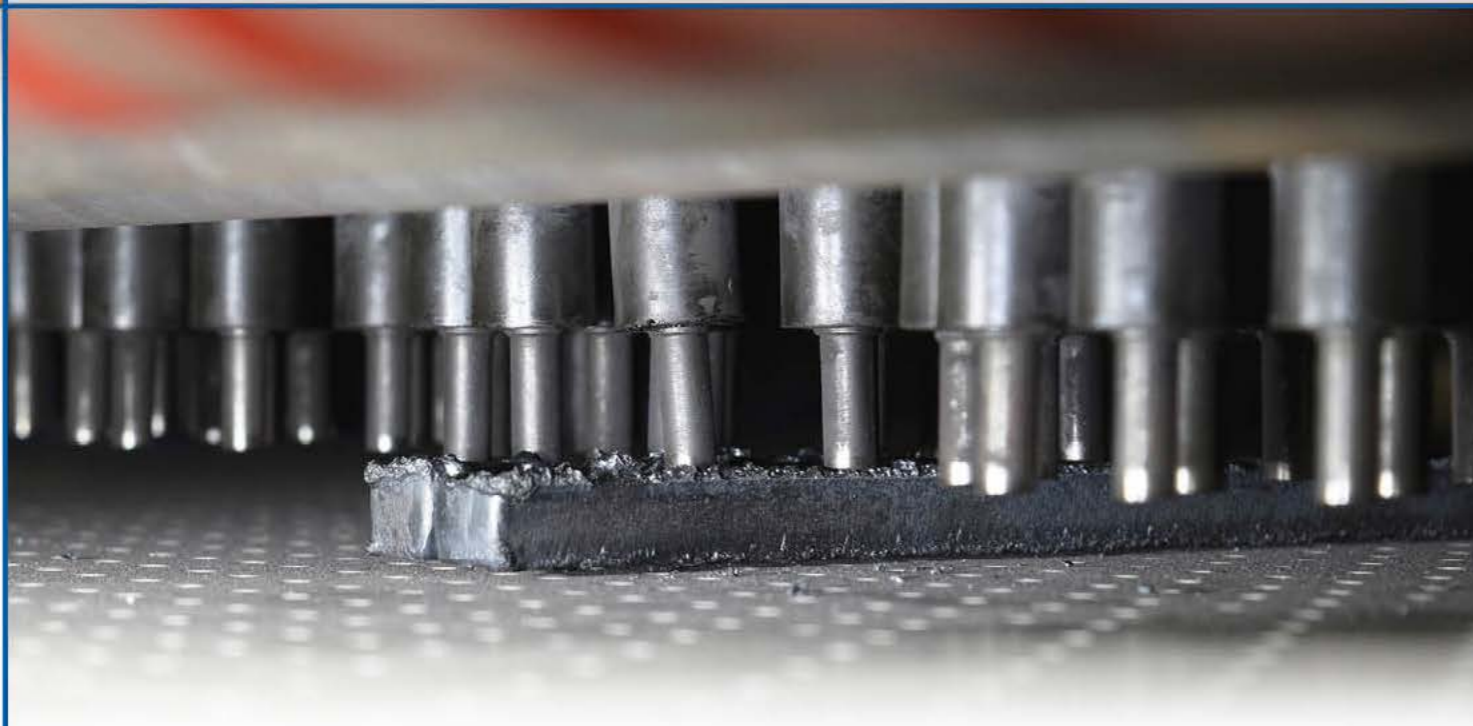

Backing pads with hardened steel pins for **HEAVY SLAG REMOVAL**

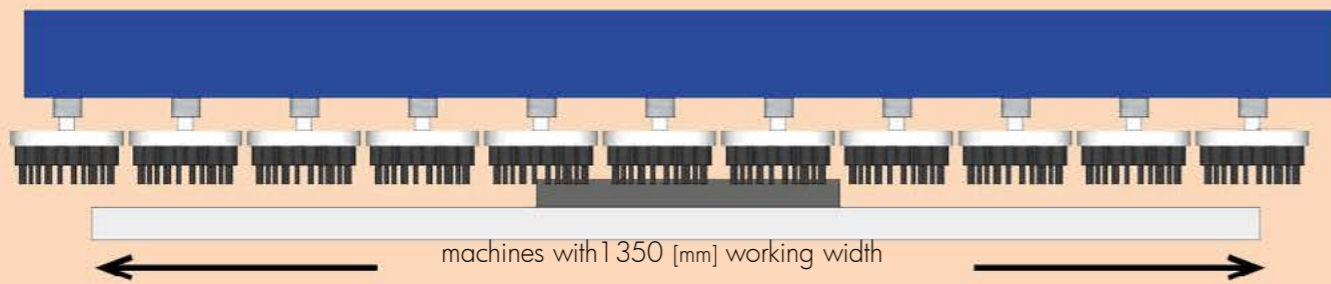

Cylinder covered with special rubber, oil and heat resistant with special high temperature bearings for high cutting speed applications.

To quickly compensate the thickness difference of the various types of abrasive belts, the cylinder is equipped with **pneumatic grit-set** with 6 position revolver (standard)

Electronic Grit-set System for centesimal positioning of the cylinder height in relation to the abrasive belt grit. Centesimal read out display on the main control panel.

Sanding belt tracking photocell.

Oscillating air jet blowers (optional) for an efficient cleaning of sanding belts, they are activated only when the workpiece is being processed.

Each working unit motor is equipped with a **disk brake** to allow the machine to stop in a few seconds in case of emergency.

Double pressure rollers with micrometric precision adjustment mounted in front and rear of each working unit.

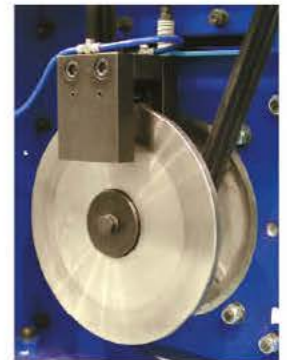

The perimetral deburring unit is composed of an identification system of the geometrical shape of the workpiece to be deburred. It is controlled by a PLC which activates a series of pneumatic sections (with 32 mm or 16 mm definition) that apply the necessary pressure on the abrasive belt on the perimeter of the workpiece only, thus removing the burrs. The advanced system management via PLC allows to vary the amplitude and the pressure of the working area as required.

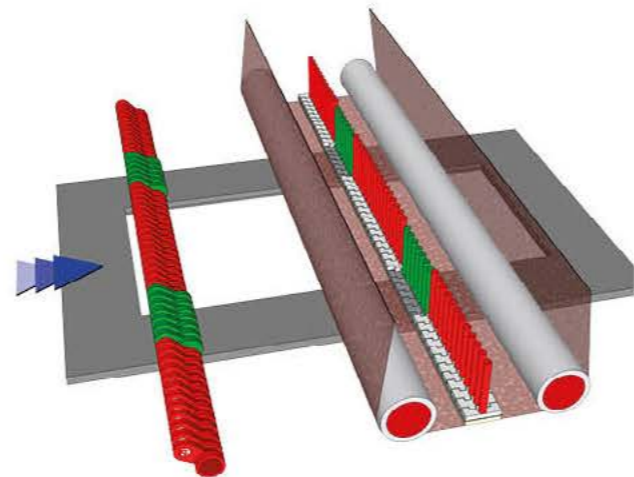

Shape detecting

infed sensing bar with rubber covered wheels and inductive sensors. It detects the presence of the workpiece along with its form and size.

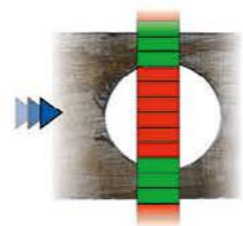

Shape processing

pressing system - acting on each-one section with pneumatic or electromagnetic pressure

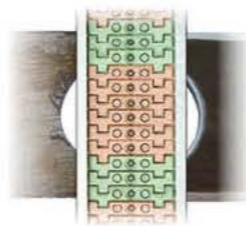

Definition Barrier (DB)

Main benefits of this working unit:

- easy **deburring** of **warped workpieces**, thanks to the excursion control of each section of the perimetral unit (up to 6mm)
- **processing** of the **edges only** (with control of width) to facilitate the welding operations;
- **burrs removing only**, without affecting the remaining surface (significant power and sanding belts savings).

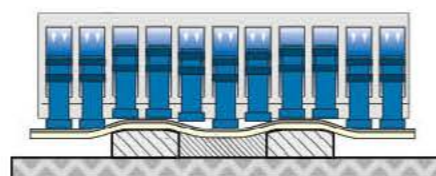

Perimetral deburring

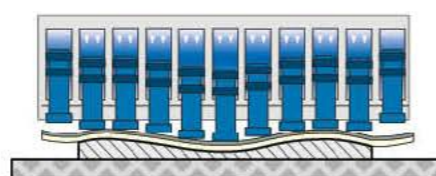

Polishing of deformed and/or uneven pieces



This unit is composed of a series of vertical brushes, rotating at high speed (inverter controlled) and oscillating side-ways at adjustable rate of oscillation.

Combining the vertical axis rotation with high frequency oscillation it allows to achieve a perfect deburring in all directions with a single working unit.

The XVS unit is ideal for a multitude of operations:

- **deburring,**
- **oxide removal,**
- **edge rounding,** etc.

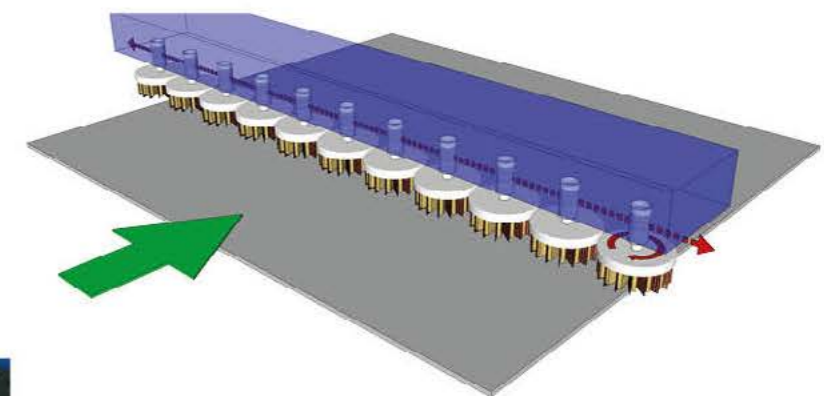

XVS Ø 130 mm with abrasive inserts for **deburring** and **edge rounding**



XVS Ø 85 with steel wires for **oxide removal**

The flexibility of the abrasive brush cups ensure a perfect burr removal also on warped parts, and on material with protective film, PVC: galvanized, pre-painted, zinc coated, etc.

The working pressure adjustment is manual controlled, or electronically through the main panel(opt.).

The pressure units are adjacent to the brush unit to reliably process small parts.

available units

XVS85
n° 15 x Ø 85 [mm]



XVS130
n° 11 x Ø 130 [mm]



for machines with 1350 [mm] working width

The XVS unit is extractable to simplify the tool change and regular maintenance and is designed to operate with standard, low-cost, brush cups as well as more specialized, custom-made, brushes.

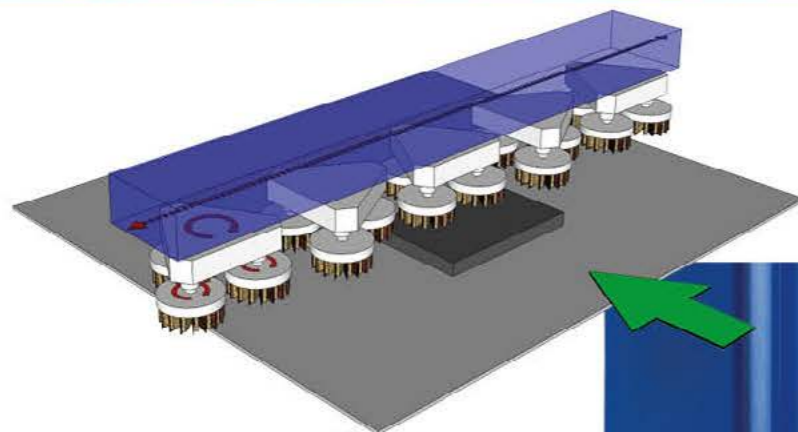
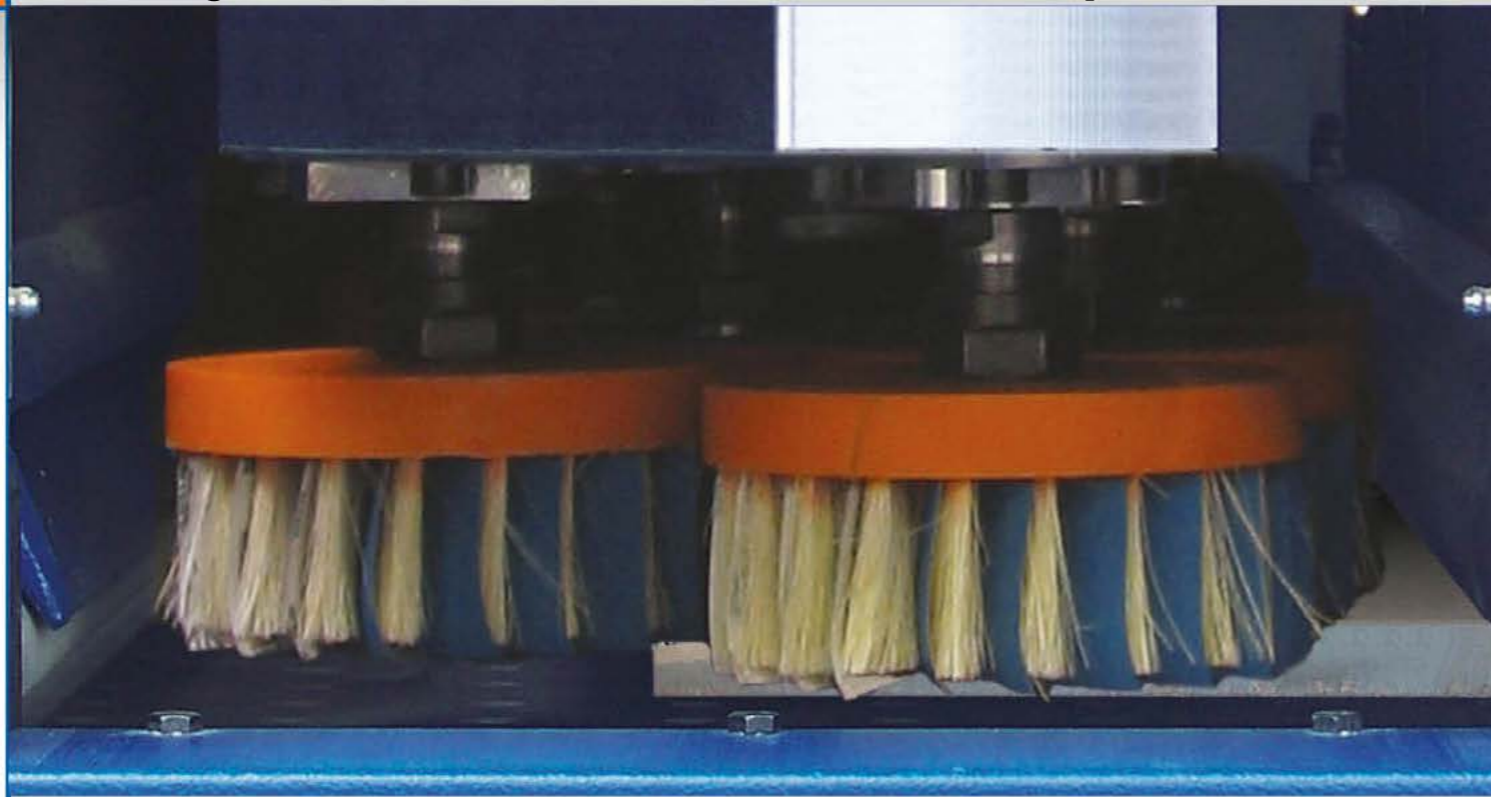

The orbital brushes rotate on their axe and at same time they rotate in number of three (inverter controlled). Furthermore, by combining the rotation with high frequency oscillation covering all working surface, we will achieve a perfectly homogeneous rounding on the edges of any geometrical shape.



The working pressure adjustment is electronically controlled through the main panel. The R unit is extractable to facilitate brush tool replacement and maintenance operations. The R unit is designed to operate with standard, low-cost, brush cups as well as custom-made brushes for special applications. This working unit is installed inside the main machine frame. Depending upon the work type and feed speed, we can configure more R units in sequence.

Optional devices

External brushing unit

The brushes can be:

- vegetal fibers for the dust removal;
- scotch-brite™ for finishing;
- with interchangeable abrasive inserts;
- steel, stainless steel or tyrex.



Scotch-Brite™ brush

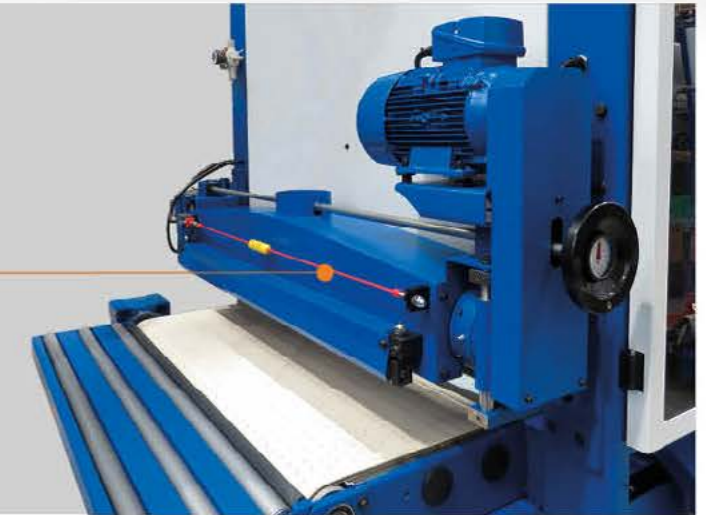

Ultra-Fine antistatic cleaning brush

Brush complete with integrated micro-moistening, self-cleaning mechanism (compressed air nozzles, roto-rack), motor with inverter

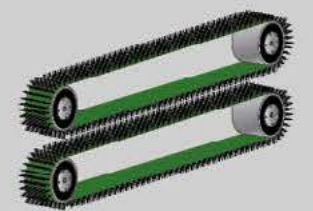
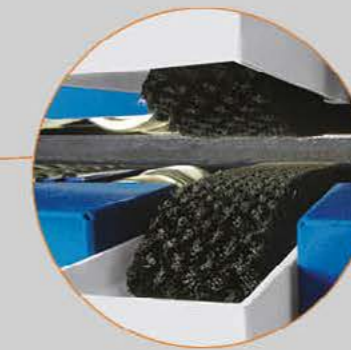

Oscillating cleaning blowers for processed parts (JL)

Timed oscillating unit for the removal of dust from the workpieces.

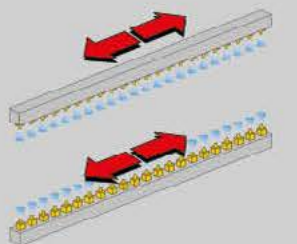

Feed belt cleaning blowers (JFB)

Positioned under the feed belt, they are connected to a timed entry system that enables automatically the blowing of air + water moisture to maintain a high grip of parts on the feed belt.

Air treatment system

The dust generated by the process is removed through an exhaust hood and conveyed to the suction filter (optional) for the collection.

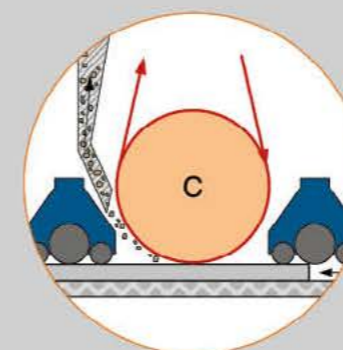

Deburring & edge rounding of punched, sheared, or laser-cut parts, using a machine in configuration "CV"

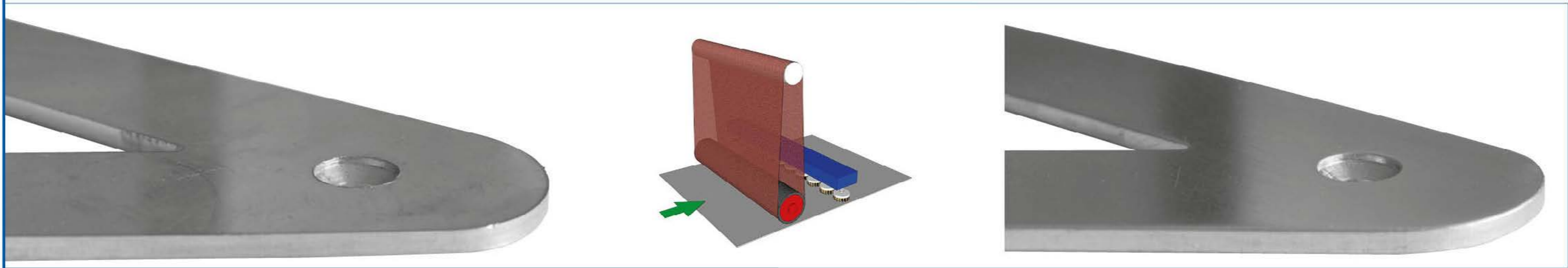

Deburring, edge rounding and polishing of laser-cut, punched, or sheared parts, using a machine in configuration "CVC"

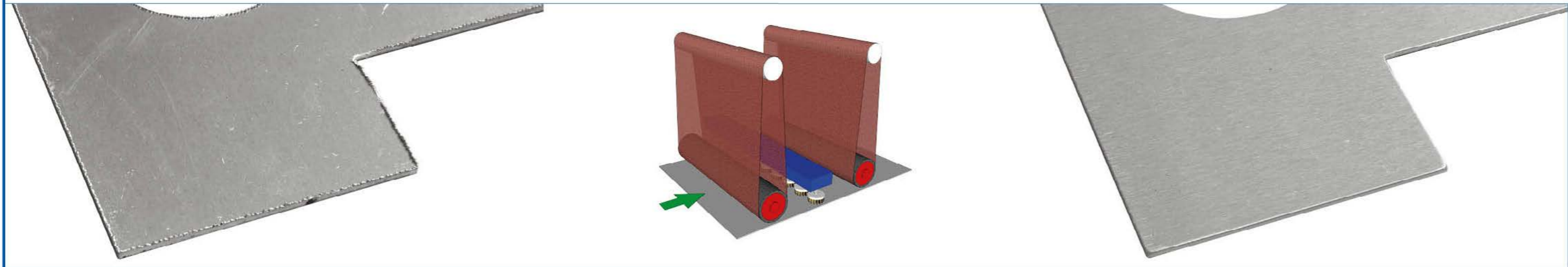

Deburring, oxide removal & edge rounding of laser-cut, using a machine in configuration "CVV"

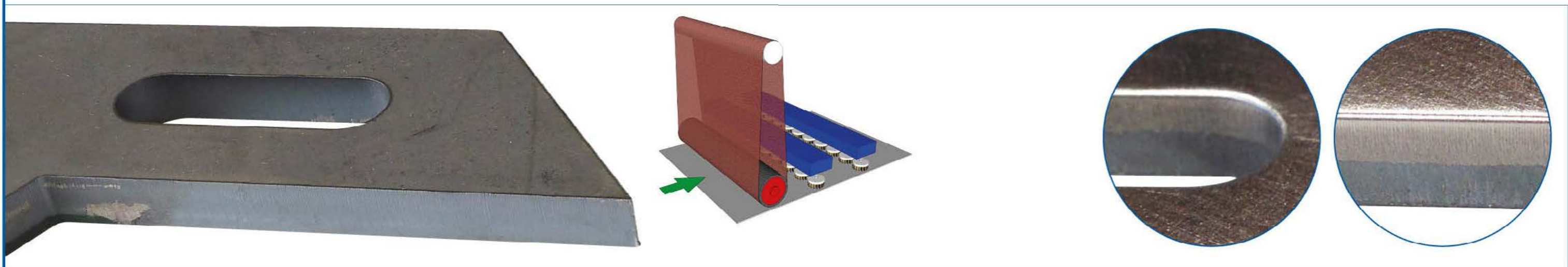

Deburring & edge rounding of oxy and plasma cut parts, using a machine in configuration "XDS C R"

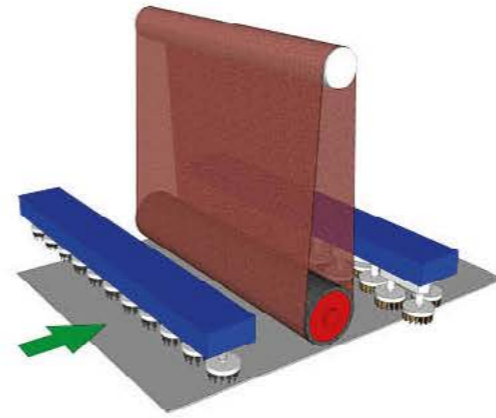

Deburring and polishing (cosmetic grinding) of hot/cold rolled stainless steel, aluminium, for Duplo finish and/or Scotch-Brite™, using a machine in configuration "CCS"

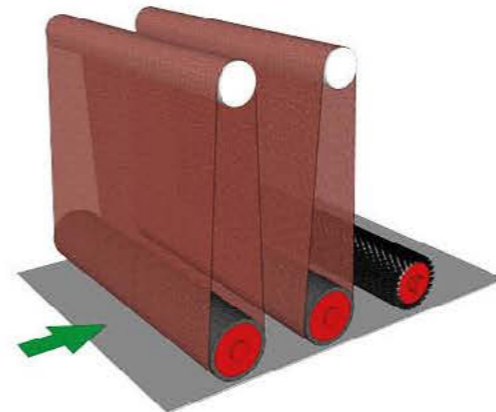

Location: Italy - Veneto



Airports

Venezia: 90 Km - 1h drive
 Treviso: 75 Km - 1,5 h drive
 Verona: 65 Km - 45 min drive
 Bologna: 160 Km - 2h drive

Train Station

Vicenza: 30 km - 30 min drive

Car Directions

To the Factories in Sandrigo
 Highway A31 - Exit Dueville - 3,5 km

To the Main Office in Schio
 Highway A31 - Exit Thiene-Schio - 13 Km



Headquarter of Schio

Via Venezia, 144
 36015 Schio



Factory of Sandrigo 2

Via G.Galilei, 5
 36066 Sandrigo



Factory of Sandrigo 3

Via Galvani, 3-5
 36066 Sandrigo



Factory of Sandrigo 4

Via Galvani, 1
 36066 Sandrigo

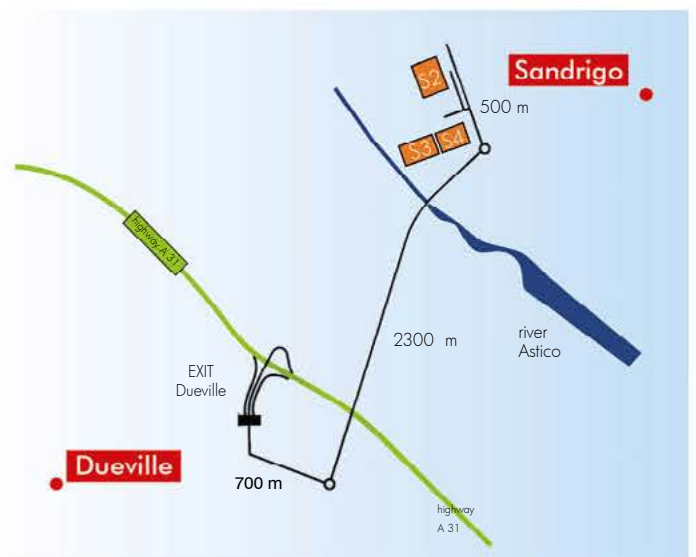
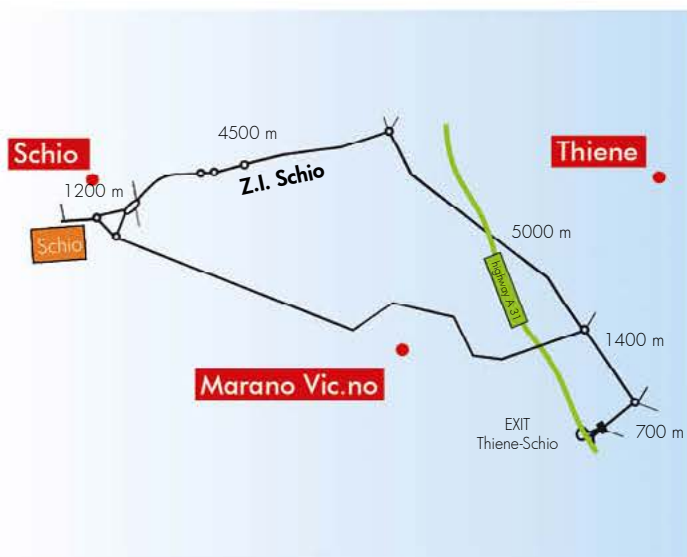

We reserve the right to change features without any notice



Costa Levigatrici S.p.A.

Via Venezia, 144 - 36015 Schio (VI) Italy
 Tel. (+39) 0445-675000 - Fax (+39) 0445-675110
 www.costalev.com - info@costalev.com