



Fred SR
With 10' capture arm

Fred ^{SR}

Self Cleaning, Portable Smoke, Dust & Fume Extractor

This professional grade fume extractor is the industry standard for eliminating smoke, dust and other unbreathables from the air. The powerful blower features a high face-velocity, removing particulate as small as 0.5 micron with our standard MERV 15 rated Nanofiber filter.

Our patented Injection Self-Cleaning System (ICS-360) reduces total cost of ownership by extending filter life expectancy, improving aggregate filter efficiency, and making routine service faster & easier.

Benefits:

- Automatic Filter Cleaning makes service easy
- Compact, portable and easy to operate
- Capture-at-source for cleaner air
- Complies with OSHA guidelines for controlling weld fumes

* Selected Models

Features:

- ICS-360 Injection Self-Cleaning System
- Flexible 10' Externally Articulated Capture Arm
- 21" easy-to-service Nanofiber filter (MERV 15)
- Rotary starter with 15' power cord & casters

Options:

- Flexible externally articulated capture arm 6.5', 10', or 13'
- Automatic self-positioning, Fume Tracker™ capture arm
- 3.0 HP 1800 CFM High-Static Motor [230/460/575V 3PH]
- Odor Absorption Kits
- Minihelic Gauge
- Spunbond Polyester Filter Cartridge (washable)
- After-filter module, with HEPA Filter
- Hood mounted LED light kit

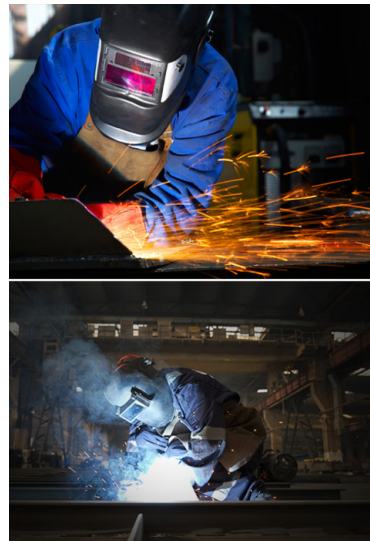

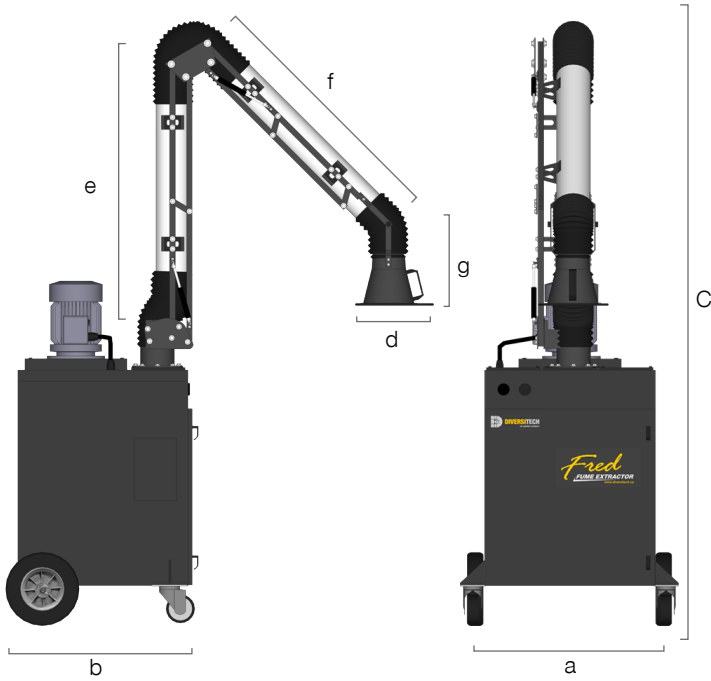

NANOTECH XV



MERV 15 efficient cartridge filter captures particles at the submicron level, and surface-loading technology allows dust to be easily dislodged during cleaning with compressed air.

EFFICIENCY:	MERV 15
FILTER MEDIA:	NANOFIBER
MEDIA AREA:	190 SQ.FT.
COATING:	FIRE RETARDANT
END CAP:	OPEN/OPEN
CLEANING METHOD:	COMPRESSED AIR
MAX TEMP:	180° F / 82° C
FLANGE:	NONE

POLYTECH XI



High strength, high efficiency (MERV 11) cartridge filter made from 100% spun-bond polyester that lowers costs, by allowing for water-based cleaning of captured contaminants.

EFFICIENCY:	MERV 11
FILTER MEDIA:	SPUN-BOND POLY
MEDIA AREA:	105 SQ.FT.
COATING:	FIRE RETARDANT
END CAP:	OPEN/OPEN
CLEANING METHOD:	AIR + WATER WASH
MAX TEMP:	180° F / 82° C
FLANGE:	NONE

Technical Specifications

Model	Motor (H.P.)	Power					Airflow (CFM)	Cord Length (ft.)	Arm Length (ft.)
		Phase (hz)	@120V (amps)	@230V (amps)	@460V (amps)	@575V (amps)			
FRED SR Portable Fume Collector with externally articulated manual capture arm									
FRED SR	1.5	1P/60Hz	13.2	---	---	---	1200	15	10 or 13
	3.0	3P/60Hz	---	7.1	3.7	3.2	1800	---	10 or 13
	5.0	3P/60Hz	---	13.0	6.5	5.2	2500	---	10 or 13

Dimensions

Model	Arm Length (ft.)	Arm Diameter (in.)	Net Weight (lbs.)	Product Dimensions (in.)							Shipping Dimensions (in.)			Gross Weight (lbs.)
				Width [a]	Height [C]	Length [b]	[d]	[e]	[f]	[g]	Width	Height	Length	
FRED SR Portable Fume Collector with externally articulated manual capture arm														
FRED SR	10	6	285	32.5	115	33	13	60	34	18.5	48	90	54	330
	13	6	290	32.5	128	33	13	60	60	18.5	48	90	54	335



**COMPLETE
METALWORKING
SOLUTIONS**

(800) 991-4225

www.ahbinc.com

ISO Certified

customerservice@ahbinc.com