

***Ebbco* inc.**

INDUSTRIAL FILTRATION SYSTEMS

MODEL # GRS-0250-B-CC

OPERATION AND MAINTENANCE MANUAL



Contents:

- Section 1 **Introduction.**
- 1.1 Introduction.
 - 1.2 Sequence of Operation.
- Section 2 **Specification.**
- 2.1 Utilities Requirements.
 - 2.2 System Specifications.
- Section 3 **System Installation and Start-Up.**
- 3.1 Installation Procedure.
 - 3.2 Start Up Procedure.
- Section 4 **Maintenance.**
- 4.1 Garnet Removal System Daily Check List.
 - 4.2 Garnet Removal Pump Suction Basket.
 - 4.3 Garnet Removal System Pump.
 - 4.4 Garnet Removal Centrifugal Separator.
 - 4.5 Work Tank Sweeper Package
 - 4.6 Abrasive Bag Hopper
- Section 5 **Troubleshooting Guide.**
- 5.1 System Troubleshooting.
 - 5.2 Pump Troubleshooting.
- Section 6 **Spare Parts.**
- Section 7 **General Policy & Limited Warranty.**
- Section 8 **Product Literature & Drawings.**
- 8.1 Pump Suction Strainer Basket.
 - 8.2 System Pump.
 - 8.3 Centrifugal Separator.
 - 8.4 General Assembly.
 - 8.5 Layout drawing.
 - 8.6 Sweeper Package.
 - 8.7 Electrical Schematic.

Section 1: Introduction

1.1 Introduction

This following technical manual provides instruction on installation and operation of the Garnet Removal System manufactured by Ebbco Inc. With correct maintenance and system operation the Garnet Removal System will keep garnet from building up in the waterjet cutting machines work tank and will increase production by eliminating down time for tank shoveling. The Garnet Removal System will require some assembly on site. This will include sweeper package assembly and connecting the Garnet Removal System to the waterjet cutting machines work tank. The Garnet Removal System is manufactured using quality materials and by highly experience production staff. The Garnet Removal System is tested in Ebbco's test department to ensure that it meets the specifications required by the customer. The Garnet Removal System is inspected and all test data documented prior to shipment.

1.2 Sequence of operation.

This system is designed to keep garnet from building up in the cutting table. The method used to achieve this is the use of agitation on the bottom of the tank by water pumped through eductor header nozzles located and directed in engineered locations. The garnet thus stays in suspension due to the agitation and is carried out of the tank by way of the heavy duty centrifugal pump. It is pumped through a centrifugal separator, which concentrates the garnet in the fluid stream and separates it for disposal into an abrasive bag hopper. Excess water that comes out of the separator when it purges the solids from the collection chamber is decanted from the hopper, returning to system tank.

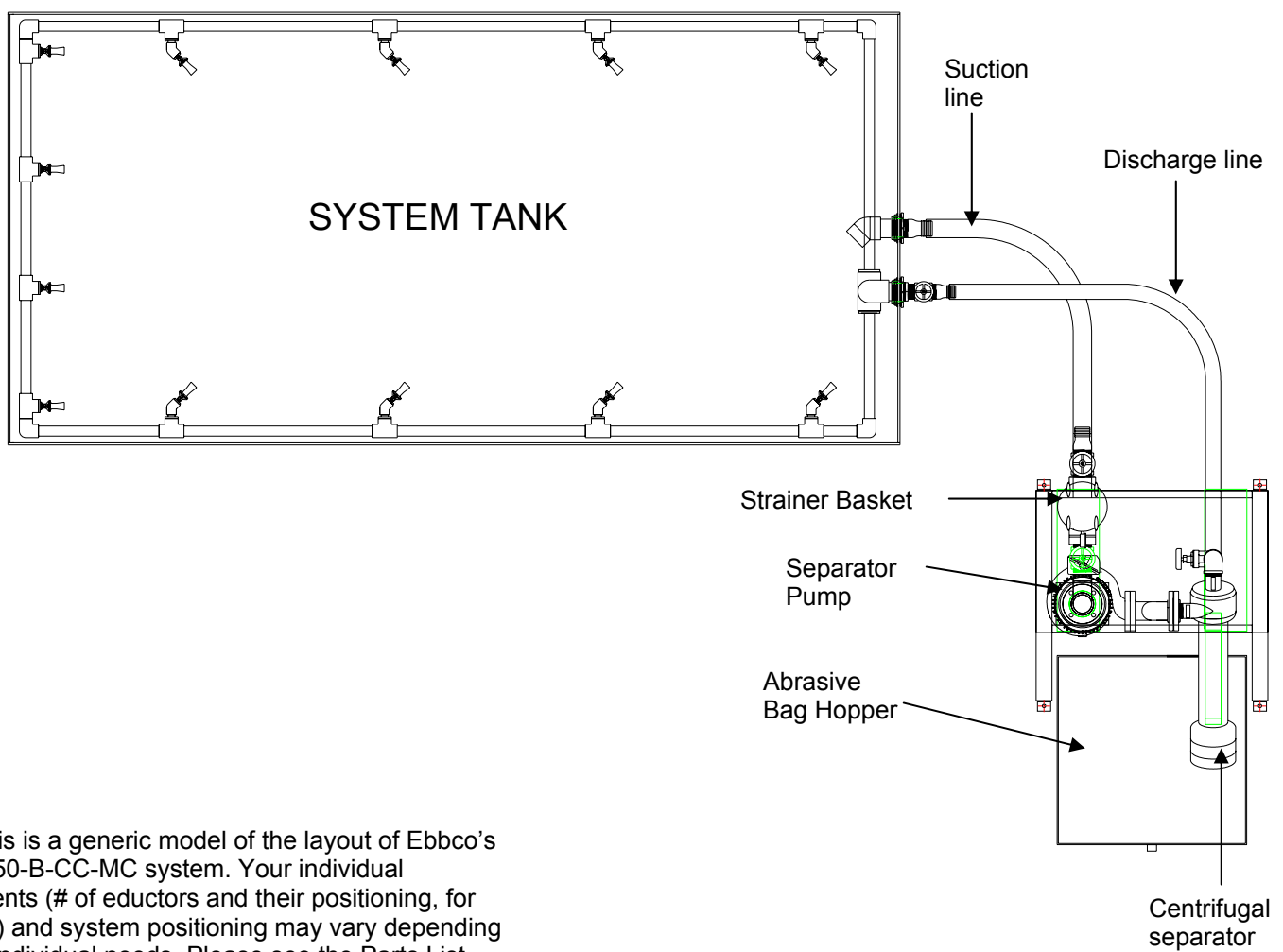

Note: This is a generic model of the layout of Ebbco's GRS-0250-B-CC-MC system. Your individual components (# of eductors and their positioning, for example) and system positioning may vary depending on your individual needs. Please see the Parts List (Section 6) for a list of your individual components.

Section 2: **System Specifications**

2.1 System utilities requirements

Inlet connection :	3" steel hose barb
Outlet connection:	2 1/2" steel hose barb
Electrical:	230vac/3ph/60Hz
Full load amps:	33.0 amps

2.2 System components

Pump suction basket – PKG-98

Cast iron housing with flanged inlet and outlet connections. Internal basket is constructed of perforated stainless steel.

System pump – PCL 2x3x10B-CC+6

Close-coupled, all iron construction, 316 stainless steel shaft sleeve, semi-open impeller.

Motor:	
Electrical:	230vac/3ph/60Hz
Horse power:	10 hp
Full load amp @ 230vac:	25.6 amps
Speed:	1760 rpm
Enclosure:	TEFC
Pump:	PCL 3x4-10-B-CC+6
Impeller:	10"dia.

Centrifugal Separator - SDS-250-B

Carbon steel construction, designed to remove 98% of particulate from liquid, sized at 74 micron and larger with a specific gravity of 2.6 or higher.

Maximum particle size:	3/8-inch
Maximum pressure rating:	150 psi
Pressure loss range:	4.5 to 12 psi

Electrical controller – EHOA-3

Disconnect supplied by others. Provide maximum upstream protection per NEC code 430-52 and table 430-152

Enclosure:	Steel, Nema 12
Transformer:	75va primary/secondary fused
Filter pump starter module:	Internal sort circuit / thermal overload.

Filter pump starter module: PKZ2

Thermal overload yellow dial set point 230vac:	Internal sort circuit / Thermal overload. 25.6 (FLA of motor)
Sort circuit red dial set point 230vac:	332.8 (13 times FLA of motor)

Pressure gauge – GRS-60-GA

Range:	0-60 psi
Face dia:	2"
Inlet size:	1/4" NPT
Case material:	Stainless/steel
Wetted parts:	Brass

Section 2: **System Specifications**

Vacuum gauge – GRS-V-GA

Range:	-30inHg - 0 psi
Face dia:	2"
Inlet size:	1/4" NPT
Case material:	Stainless steel
Wetted parts:	Brass

Abrasive bag hopper – 1-CUYD-ABH

All carbon steel construction. 1 cubic yard capacity. 3" coupler on decant outlet.

Section 3: **System Installation and Start-Up**

3.1 Installation Procedure

1. Upon receipt of the system, carefully check each component against the bill of materials to ensure that everything has been received with the system. If anything is missing or damaged, immediately contact the freight company to file the appropriate claim.
2. Remove system from wooden 2 x 4 undercarriage using suitable materials handling equipment.
3. Install catcher tank sweeper package as shown in the sweeper layout drawing provided.
4. Install the gate valve to the suction port on the catcher tank.
5. Install the gate valve to the discharge port on the catcher tank.
6. Install hose barbs into the suction and discharge gate valves.
7. Close the suction and discharge valves.
8. Fill the catcher tank with water.
9. Position system next to waterjet machine as discussed with Ebbco Inc. Anchor system to floor as necessary.
10. Using the black suction hose and clamps provided in the installation kit, connect the suction barb on the catcher tank to the suction barb on the garnet removal system.
11. Using the black discharge hose and clamps provided in the installation kit, connect the discharge barb on the catcher tank to the discharge barb on the garnet removal system.
12. Place abrasive bag hopper under purge outlet. Connect decant line to fitting provided on hopper.
13. Connect the overflow piping from the 3" port on the abrasive bag hopper to the garnet pump column.
14. Have a qualified industrial electrician connect the 3 phase electrical power to the control panel as per electrical drawing. (230vac/3 ph/60Hz)

3.2 Start Up Procedure:

1. Check the pump suction basket for debris.
2. Open the suction and discharge valves on the catcher tank.
3. Ensure that the catcher tank is full of water.
4. Check pump for correct rotation (clockwise as viewed from the top of the motor) by bumping the HOA switch, located on the main electrical panel.
5. The pump motor on the filtration system has been synchronized at the factory if the pump motor is running in reverse have a qualified electrician swap over one of the in coming line powers at electrical panel.
6. Turn the HOA switch to the HAND position.

Warning! If the filtration system dose not prime after 5 seconds, stop the system. Try three more times and if the system still will not prime call the Ebbco service department 1-586-716-5151

7. Check separator inlet and outlet pressure gauges to ensure differential pressure is between 4 and 12 psi.

Section 3: **System Installation and Start-Up**

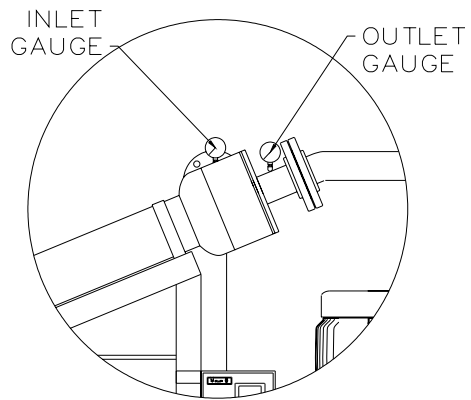

Warning If pressure differential is too low or is too high, call the Ebbco service department 1-800-991-4225

Section 4: **System Maintenance**

4.1 Garnet Removal System Daily Check List

Warning Always disconnect power and relive pressure from the system before performing any maintenance on this filtration system.

Caution Always follow correct lock out procedures when working on this filtration system.

Warning Failure to keep suction above -10 in/hg could result in catastrophic pump failure.

1. Make sure suction basket is serviced (empty).
2. Open all gate valves.
3. Start filtration system.
4. Check suction basket pressure gauge. At start up this should read approximately -3 in.hg – service basket before the suction vacuum gauge reads -10 in.hg.
5. Check inlet and outlet gauges on top of separator. These pressure readings should be approximately 35 psi on the inlet gauge and approximately 26 psi on the outlet gauge. Separator must run between 4 and 12 psid.

Warning This garnet removal separator must run between these pressure differentials. If the system does not maintain the proper differential pressure it will affect the garnet removals performance and can cause premature pump maintenance/failure.

6. Service hopper as needed.
7. In front of the eductors there will be no garnet accumulation, however there maybe some quite areas in the tank where garnet may collect. The garnet "pile" should not be allowed to exceed 6" in height. Monthly checking of garnet build up on the tank bottom is advised, using a stick tap on the tank bottom in various locations. Any garnet accumulation will show up on the stick and it can be easily removed.

**If there are any questions regarding this system please call the Ebbco Service Department at
1-800-991-4225**

Section 4: **System Maintenance**

The system will require the following items to be maintained on a scheduled basis.

Warning Always disconnect power and relieve pressure from the system before performing any maintenance on this filtration system.

Caution Always follow correct lock out procedures when working on this filtration system.

4.2 Pump Suction Basket

The vacuum gauge located on the pump suction basket should be monitored every time the system is started and then after every 8 hours of operation to ensure that the suction does not exceed -10 in/hg.

The pump suction basket should be removed and emptied every 8 hours of operation. It is important to check the condition of the gasket on basket's lid, make sure it is free of dirt and is firmly in place before turning the system back on.

Ebbco recommends that a preventive maintenance schedule be implemented for this component.

Note: The vacuum gauge must read -3 in.hg – service basket at -10 in.hg.

4.3 System Pump

The centrifugal pump has been tested and greased at the factory; therefore lubrication is not necessary for a period of approximately six to eight months. Remember that over greasing will cause the bearing to run hot, so grease bearings sparingly when it is necessary. Ebbco recommends the use of sri # 2 chevron ball bearing grease.

Applications where there is a high abrasion the pump may have to be inspected quarterly for wear on impeller and impeller housing.

It is recommended that a routine maintenance schedule be set up and followed for the best service of the pump. A periodic comparison of existing operating conditions and data against data taken when pump was initially started may indicate a problem developing and allow for a planned maintenance check before a breakdown occurs.

4.4 Centrifugal Separator

There is no scheduled maintenance on the separator itself.

Section 4: **System Maintenance**

4.5 Work Tank Sweeper Package

To ensure that the garnet removal system works at the designed performance the work tank sweeper package must be visually inspected every 12 months. If the sweeper package is damaged (broken eductor or piping, blocked suction) there will be a noticeable change in system performance. This may manifest itself as a separator inlet pressure drop, a low differential across the separator or a high vacuum gauge reading. If any of these conditions occur and are not corrected the system pump and other components will become damaged.

Once the work tank has drained of water:

- Check for damaged or broken piping and eductors.
- Check for any garnet build up in front of any eductor.
- Check for any material that may be wedged between the eductor nozzle and the horn.

Ebbco Inc can provide an experienced service technician to service the tank sweeper package and inspect the complete system. Please call Ebbco for pricing and to schedule a service technician.

4.6 Abrasive bag hopper

The hopper should be visually inspected to be aware of solids level, service when full.

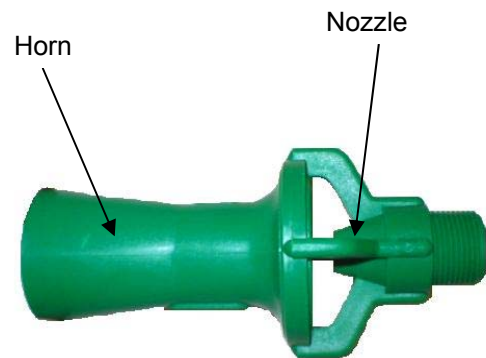

Section 5: **Troubleshooting Guide**

5.1 System Troubleshooting

Warning Always disconnect power and relive pressure from the system before performing any maintenance on this filtration system.

Caution Always follow correct lock out procedures when working on this filtration system.

1. Pump will not start

- a. Check the electrical hookup for proper direction and power requirements.

Warning do not operate the pump without the inner basket inside the strainer

2. No flow/no pressure

- a. Check the electrical hookup for proper direction and power requirements. The pump's motor should run clockwise looking down from the top.
- b. Check fuses in step-down transformer. Replace as necessary.
- c. Check the motor for any foreign objects.

3. Decreasing flow and pressure during operation

- a. Check the pump protection strainer for fouling. If plugged, remove the contaminants. Caution: do not operate the pump without the inner basket inside the strainer.

4. Low flow/low pressure (10 psi or less)

- a. Check the rotation of the pump motor. It should be running in the direction noted in 1.a.
- b. Check the pump protection strainer for fouling.

5. No flow/maximum pressure (pegged gauges)

- a. Check the separator's purge area for blockage.

6. No transfer of solids/correct separator pressure/correct separator flow

Check for blockage in purge area.

Section 5: Troubleshooting Guide

5.2 System Pump

For troubleshooting pumps, read symptom describing problem, consult keyed causes and correct those that apply. Caution: be sure unit's power is disconnected before attempting any work on pump or motor.

SYMPTOM		KEY NUMBERS FOR CAUSES
A	Pump does not deliver liquid	1,2,3,4,6, 10,12,14,15,20,21
B	Pump delivers too little flow	2,3,4,5,6,7, 10,11,12,13,15,18,20,21,27,28
C	Delivery pressure too low	5,12,13,14,15,18,20,27,28
D	Pump loses prime after starting	2,3,5,6,7,10
E	Pump needs too much power	13,15,16,17,18,21,22,24,25,27
F	Seal leaks	22,24,29,30
G	Pump vibrates or is noisy	2,3,4,10,19,21,22,23,24,25,26,28,29,30,31,32,33,34
H	Motor bearings have short life	22,24,25,26,29,30
I	Pump overheats and/or seizes	1,4,19,20,22,25,26,29,30

CAUSES			
1	Pump not primed	18	Viscosity of liquid different than design
2	Pump or suction pipe not completely full of liquid	19	Pump operating at very low capacity
3	Suction lift too high	20	Parallel operation of pumps unsuited for such operation
4	Pump cavitating, increase suction pressure	21	Foreign matter in impeller
5	Excessive amount of air/gas in liquid	22	Misalignment of pump or piping
6	Air pockets in suction pipe	23	Foundations not rigid
7	Air leakage in suction pipe	24	Shaft bent
		25	Rotating part rubbing on stationary part
		26	Bearings worn
10	Suction pipe not sufficiently submerged	27	Wear ring worn
11	Impeller, suction or trap partially or completely plugged	28	Impeller damaged
12	Speed too low	29	Shaft running off center due to worn bearings or misalignment
13	Voltage wrong or too low	30	Impeller out of balance resulting in vibration
14	Wrong direction of rotation	31	Excessive grease in bearing causing high bearing temperature
15	System head too high for pump design	32	Lack of lubrication
16	System head too low for system design	33	Dirt in bearings
17	Specific gravity of liquid different than design	34	Rust in bearings due to water getting into motor

Section 6: **Parts List**

REC. ON SITE	QTY REQ.	DELIVERY TIME	COMPONENT DESCRIPTION	LOCATION OF PART ON SYSTEM	PART NUMBER
N/A	1	2-4 weeks	Centrifugal separator	On separator support frame.	SDS-0250-B
N/A	1	2-4 weeks	Complete pump	On pump base.	PCL2x3-10-B-CC+6
1	1	2-4 weeks	Pump impeller	Inside pump impeller housing.	PCL2x3-10-B-CC+6-IMP.10"
1	1	Stock 2-5 days	Pump case gaskets	Inside pump impeller housing.	61115
1	1	Stock 2-5 days	Pump strainer basket's internal basket	Inside pump suction strainer.	PKG-98-IB-SS
1	1	Stock 2-5 days	Pump strainer basket's lid gasket	On suction basket lid.	U9-46
2	2	Stock 2-5 days	0-60 psi liquid filled pressure gauge	Separator inlet/outlet.	GRS-60-GA
1	1	Stock 2-5 days	Vacuum gauge -30 in/mg 0PSI	On side of pump suction strainer basket.	GRS-V-GA
N/A	1	Stock 2-5 days	Abrasive bag hopper bag	In abrasive bag hopper.	GRS-ABH-B
12	12	Stock 2-5 days	3/8" poly eductor	End of clean discharge in system tank.	OMP

Section 7: **General Policy & Limited Warranty**

It is Ebbco's policy to ship and charge for replacement parts upon notification of a problem. Warranty will be determined upon inspection of said part after it is returned to Ebbco, freight pre-paid. A returned goods claim form will be sent with replacement part and must be returned with defective part. Ebbco Inc. shall not be liable for incidental and consequential losses and damages under this expressed warranty, any applicable implied warranty, or claims for negligence.

All products manufactured and marketed by Ebbco are warranted to be free of defects in materials and workmanship for a period up to one year for date of delivery or 2080 hours of operation, whichever comes first.

Equipment such as pumps, pump bodies, separators, etc. will carry one-year manufacturer warranty. Pump seals: Ninety day limited warranty.

This limited warranty does not cover any products, damages or injuries resulting from misuse, neglect, normal expected wear, chemical-caused corrosion, improper installation or operation contrary to Ebbco's recommendations. Nor does it cover equipment which has been modified, tampered with or altered without authorization.

No other extended liabilities are stated or implied and this warranty in no way covers incidental or consequential damages, injuries or cost resulting from any such defected product.

Product Profile

HEAVY DUTY SUCTION STRAINER BASKET

MODEL # PKG98 & PKG51

PRODUCT FEATURES

THE HEAVY DUTY SUCTION STRAINER BASKET IS USED AS THE FRONT LINE PUMP PROTECTION. EBBCO INC SUCTION STRAINER BASKET HAS A RUGGED ONE PIECE CAST IRON BODY WITH A CAST IRON LID. BASKET MATERIAL AS STANDARD ON THE PKG-51 IS ABS AND STAINLESS STEEL GR303 ON THE PKG-98. A STAINLESS STEEL BASKET IS PROVIDED AS AN OPTION FOR THE PKG-51.

ALL LID GASKET MATERIAL IS BUNA-NITRILE AS STANDARD WITH EPDM AND VITON AS OPTIONS.

- RUGGED CAST IRON HOUSING.
- PKG-98 STAINLESS STEEL PERFORATED BASKET.
- PKG-51 ABS INTERNAL PERFORATED BASKET. OPTIONAL STAINLESS STEEL.
- BUNA-NITRILE LID GASKET.

MODEL PKG98

MODEL PKG51



STAINLESS
STEEL BASKET



Ebbco inc.

METALWORKING FILTRATION & FLUIDS

THIS IS A PROPRIETARY
DOCUMENT OF EBBCO, INC.

www.ebbcoinc.com

Specifications

HEAVY DUTY SUCTION STRAINER BASKET

MODEL # PKG98 & PKG51

	PKG-51	PKG-98
RECOMMENDED	GPM	150 GPM
MAX FLOW RATE		300 GPM
MAX TEMP	180°F	180°F
MAX PRESSURE	PSI	PSI
LOSS		
INLET	2" NPT	3" NPT
OUTLET	SQ. FLANGE	SQ. FLANGE
MATERIALS OF CONSTRUCTION		
BODY	CAST IRON	CAST IRON
LID	CAST IRON	CAST IRON
O-RING	BUNA-N	BUNA-N
BASKET	ABS (OR SS)	SS

SPARE PARTS

O-RING	U9-46	U9-171
FLANGE	C20-19	C20-19
GASKET		
LOCK HANDLE	C154-18D	C154-18D
LID	C3-30	C3-105
ABS BASKET	C108-11P	N/A
SS BASKET	C108-11SS	16401-0030

MODEL #PKG-98

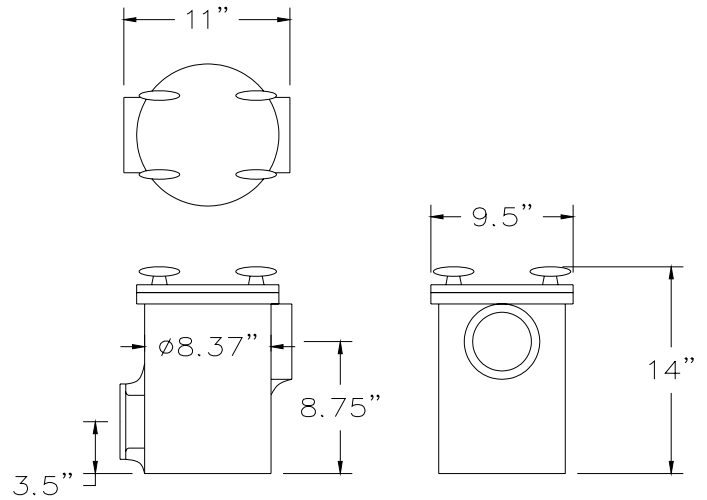

MODEL #PKG-51

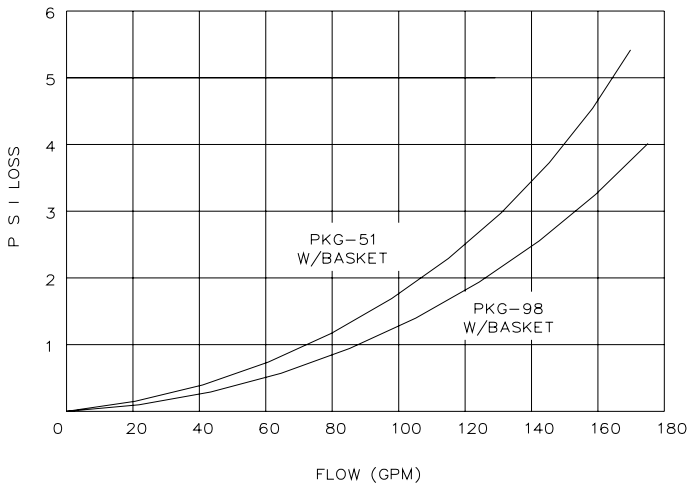
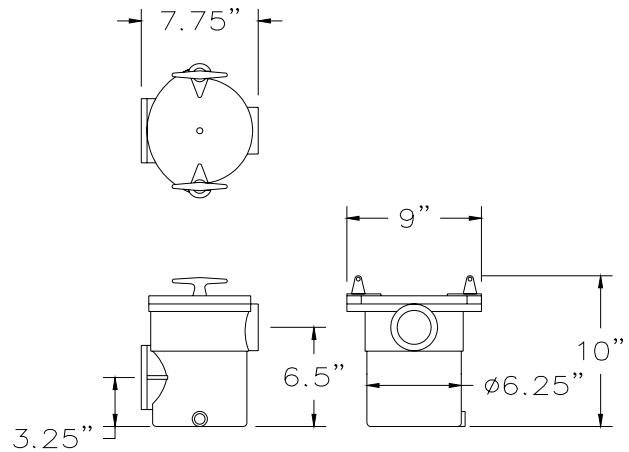

GUSHER[®]

PUMPS

MAINTENANCE • INSTALLATION • OPERATION

7550 SERIES
52 HEAVY DUTY, 53 HEAVY DUTY
AND 54 HEAVY DUTY POWER FRAMES

INDEX

Warranty.....	2
Receiving and Inspection.....	2
Installation	
Pump Positioning.....	3
Pipe Connection.....	3
Impeller Adjustment.....	3
Coupling Alignment.....	3
Maintenance	
Lubrication.....	4
Coupling Alignment.....	3
Disassembly	
Chair and Drive Motor.....	5
Barrel and Drive Motor.....	5
Pump.....	5
Pipe Friction Chart.....	14
Bearing Installation.....	7
Trouble Shooting.....	8
Cross Section Drawings	
52V Heavy Duty Power Frame.....	9
53V & 54V Heavy Duty Power Frame.....	10
Parts List Covering (Power Frames).....	11
Parts List Covering (Basic Pump).....	11
Parts List Covering (Stem).....	11
Maintenance History.....	16
Engineering Data.....	12, 13, 14, 15

WARRANTY

Gusher Pumps, Inc. will replace or repair, within one year of shipment from our plant, any pump in our judgement that has failed due to defects in materials or workmanship, provided the pump has been properly installed and maintained and has not been subject to abuse. These pumps must return to Gusher Pumps, Inc. with complete history of service for inspection and warranty consideration. Gusher Pumps, Inc. does not accept the responsibility for transportation to and from our plant. Furthermore, we do not assume any responsibility for consequential damage or loss of production.

RECEIVING AND INSPECTION

The utmost care has been taken at the factory to assure proper coupling alignment and impeller adjustment. However, due to circumstances beyond our control, YOU MUST inspect the pump upon receipt and follow the installation instructions completely before start-up.

RECEIVING:

1. Rotate shaft by hand. If it does not rotate freely:
 - a. Check impeller adjustment.
 - b. Check for bent coupling guard.
 - c. Check slinger (#8).
 - d. Check for bent shaft (#1).
2. Check for cracked or damaged parts. If upon receipt, you find the pump damaged, file a claim with the delivering carrier.
3. If drive motor has been supplied, check the R.P.M. and horsepower to be sure it is correct as ordered.
4. Check the pump name tag to be sure we have shipped correctly as ordered:
 - a. Model Number
 - b. Head in feet (Ft. Hd.)
 - c. Gallons per minute (G.P.M.)
 - d. Construction:
 1. All iron.
 2. All iron with stainless steel shaft and impeller.
 3. All stainless steel.
5. If there is anything that appears to be incorrect, call the factory immediately.

INSTALLATION

After careful preliminary inspection, you may proceed with the installation of the pump into your system.

1. Lower the pump into system.
2. Make sure mounting plate (#37) is setting firmly on the support channels. (It may be necessary to use metal shims to level plate.)
3. Secure mounting plate (#37) by using hold-down screws in all four corners. Again, care must be taken to make sure plate is firm and level. **DO NOT** force bowed plate level. Use metal shims if necessary.
4. Making pipe connections:
 - a. Extreme care must be taken to support piping without causing any strain on the pump.
 - b. Install pipe hanger on the discharge pipe so all piping weight is supported by the hanger and not be the pump or the casing.
 - c. Bolt holes must line-up without prying to insert bolts.
 - d. When tightening flange bolts, pipe flanges must not be forced together.
 - e. Check valve should be placed in discharge line between gate valve and pump discharge pipe to prevent liquid from running back through the pump and causing reverse rotation. This is extremely important in applications with intermittent duty where the pump may be rotating backwards when service is resumed. This will cause damage to the pump and the drive motor.
 - f. Pressure gauge should be located at the pump discharge, as all performance data is taken at pump discharge.
 - g. If intake piping is used to pump the tank down, it must also be supported independently of the pump.
5. Remove coupling guard and rotate coupling by hand. Pump should rotate freely at this point. If it does not, check for:
 - a. Piping strain: without exception, piping must not rest on pump in any manner. (SEE ITEM #4 of the INSTALLATION SECTION.)
 - b. Impeller adjustment:
 1. Disconnect coupling (#32) and remove sleeve (#32a).
 2. Loosen three locking screws (#57).
 3. Loosen three adjusting screws (#55).
 4. Lightly tap shaft (#1) until impeller (#12) bottoms on the intake flange (#13).

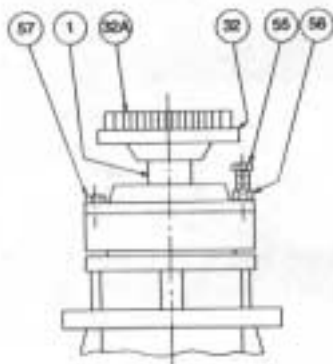
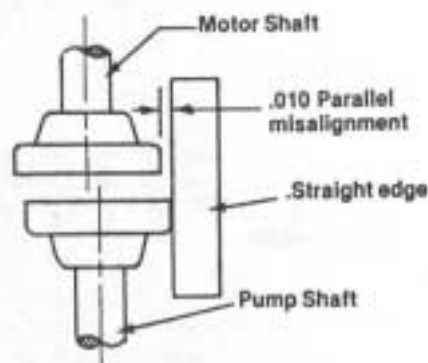
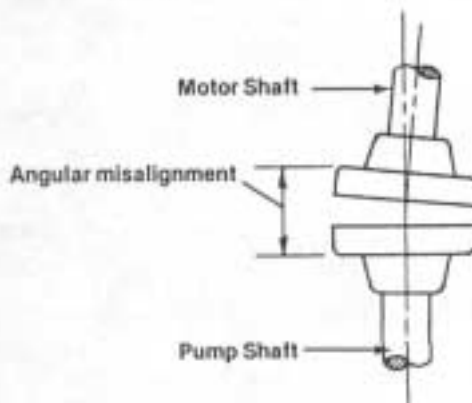

FIG. #1

5. Tighten three adjusting screws by hand until they touch ball bearing housing (#5).
6. Tighten three adjusting screws 1/4 turn (approximately .016") by alternating from one screw to the next, until all three screws have been turned 1/4 turn.
7. Tighten locking screws (#57) and jamb nuts (#56).
8. Rotate coupling by hand to be sure impeller (#12) does not rub intake flange (#13). If impeller does rub, repeat steps #1 through #7.
9. Connect Coupling.
 - c. Slinger adjustment: The slinger (#8) is set at the factory and normally causes no problems, but should be checked when unit is inspected upon arrival at your plant site and before unit is lowered into position in your system.
 - d. Coupling alignment – SEE ITEM #6 below:
6. Coupling alignment: **MUST BE CHECKED** before and after system start-up.
 - a. Check parallel alignment by placing a straight-edge across the two coupling flanges and measuring the maximum offset at various points around the periphery of the coupling. If the maximum offset exceeds .010", realign the coupling.



- b. Check angular alignment with a micrometer or caliper. Measure from the outside of the one flange to the outside of the other at intervals around the periphery of the coupling. Determine the maximum and minimum dimensions. **DO NOT** rotate. The difference between the maximum and the minimum must not exceed .010". If a correction is necessary, be sure to recheck the parallel alignment.



CHM STYLE ONLY (chair mounted style)

c. If coupling alignment is out, adjustment can be made by the following steps.

1. LATERAL PARALLEL MISALIGNMENT is adjusted by loosening the four motor retaining bolts (#49) after which you loosen the lateral adjusting screws (#58) on the side of the motor that has to be shifted and tighten the remaining lateral adjustment screws until lateral parallel alignment is achieved. (SEE FIG #3) If misalignment is our more than .020" SEE #5.

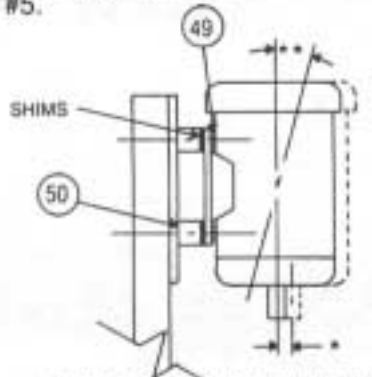

* HORIZ. PARALLEL MISALIGNMENT
 ** HORIZ. ANGULAR MISALIGNMENT

FIG. #2

2. HORIZONTAL PARALLEL MISALIGNMENT is adjusted by loosening the four motor retaining bolts (#49) after which you add or subtract shims from between motor base and motor support pads (#50). (SEE FIG #2) If more .1875 of an inch total shims are required or alignment cannot be achieved without any shims, SEE #5. Tighten all screws before operating pump.
3. LATERAL ANGULAR MISALIGNMENT is adjusted by loosening the four motor retaining bolts (#49) after which you loosen the angular alignment screws (#59) on the side of motor that has to be lowered and tighten the angular alignment screws on side of motor that has to be raised, until angular alignment is achieved. (SEE FIG #3) Tighten all screws before operating.
4. HORIZONTAL ANGULAR MISALIGNMENT is adjusted by loosening the four motor retaining bolts (#49) after which you add or subtract shims from between motor base and motor support pads (#50). (SEE FIG #2) Tighten all screws before operating pump.
5. If lateral alignment and horizontal parallel alignment cannot be achieved with the above steps use the following operation. Loosen nuts or screws that hold bearing housing to mounting plate. Tap ball bearing housing (#5) with lead hammer to move coupling into alignment. If unable to align coupling by tapping the ball bearing housing then insert a prybar between the ball bearing housing and the burned out hole in the mounting plate (#37) and shift coupling into alignment by prying housing from one position to another as required. Tighten all screws before operating pump.

NOTES:

1. DO NOT LOOSEN THE FOUR MOTOR SCREWS TO MUCH, AS THIS WILL CAUSE DIFFICULTY WHEN TRYING TO ALIGN COUPLING. Motor screws must be snug so a slight force must be applied to move motor.

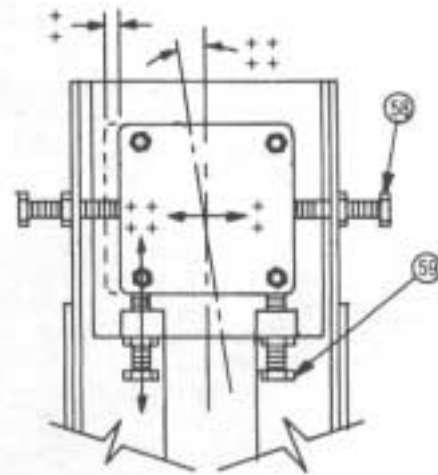

+ LATERAL PARALLEL MISALIGNMENT
 +* LATERAL ANGULAR MISALIGNMENT

FIG. #3

2. If an adjustment in either parallel or angular alignment is required, you must check both after adjustment is made.
3. Coupling alignment must be checked after system has been operating for 300 hours. Then as a preventative maintenance procedure, it should be checked every 1200 hours of normal operation. More sever duty operation requires more frequent attention.
7. Make electrical connection to conform with state and local codes. (It is advised to use approximately 4' length of flexible conduit to facilitate removal of chair, if repair is required.)

Upon initial start-up, pumps may seem to run tight and hot. This is caused by breaking-in of oil seals and ball bearings. Pump will operate normally after approximately 150 hours of service. Ball bearings should not run over 225° F. When checking temperature use a pyrometer.

MAINTENANCE

1. Lubrication – all pumps are lubricated at the factory and should not require additional lubrication for approximately 1200 hours of run at 1750 R.P.M. OR 600 hours if run at 3450 R.P.M. A well planned maintenance schedule can only be devised after careful observation of the pump for the first six months of operation and the lubrication that has been required. Each pump installation is unique and requires a different lubrication schedule compatible with that specific operation. Use Chevron SRI #2 ball bearing grease. DO NOT OVER GREASE as it will cause ball bearings to run hot.

To lubricate:

- a. Remove pipe plug from back of ball bearing housing (#5).
 - b. Fill with grease until fresh grease flows from opening.
 - c. If automatic lubrication system is being used, reliefs must be placed in the tapped hole (1/8" N.P.T.).
2. Coupling alignment: This must be checked before and after system start-up; after 300 hours of operation; and again after 1200 hours of operation. Follow procedure given in ITEM #6 of the INSTALLATION SECTION of this manual. Again, we recommend strongly that a routine preventative maintenance schedule be devised and followed to achieve optimum life and performance from the pump.

DISASSEMBLY

A. CHAIR AND DRIVE MOTOR

1. Disconnect electrical leads. During installation it was advised to allow sufficient flexible conduit (approximately 4 feet) to allow removal without disconnection of electrical leads.
2. Remove coupling guard.
3. Disconnect coupling (#32).
4. Remove four motor retaining bolts (#49). Motor can now be removed from chair.
5. Break welds loose that hold discharge pipe cover plate to mounting plate (#37).
6. Remove bolts & nuts that hold discharge pipe to impeller housing (#11).
7. Remove discharge pipe.

52VHD Power Frame

- a. Remove bolts, nuts & washer that hold chair (#34) to stem (#7).
- b. Remove chair (#34) from pump.

53VHD & 54VHD Power Frames

- a. Remove intake flange (#13).
NOT APPLICABLE ON ALL MODELS.
- b. Remove impeller housing (#11).
- c. Remove impeller retaining nut (#40).
- d. Remove impeller retaining washer (#18).
NOT APPLICABLE ON ALL MODELS.
- e. Remove impeller (#12).
- f. Remove impeller drive key (#19) and tape it to the hub of the impeller so it will not get lost.
- g. Loosen set screws in slinger (#8).
- h. Remove stem plate (#41).
NOT APPLICABLE ON ALL MODELS.
- i. Remove stem (#7).
- j. Remove power frame assembly from chair (#34).

B. BARREL AND DRIVE MOTOR

1. Disconnect electrical leads. During installation it is advisable to allow sufficient flexible conduit (approximately 4 feet) to allow removal without disconnection of the electrical leads.
2. Remove coupling guard.
3. Disconnect coupling (#32).
4. Remove bolts that hold barrel (#36) to bearing housing (#5).
5. Remove barrel (#36) & motor from power frame.

C. PUMP DISASSEMBLY

Read thoroughly before disassembly.

1. 52VHD barrel mount or chair mount.
 - a. Follow steps in section A or B
 - b. Remove bolts nuts and washers that hold discharge pipe to the impeller housing (#11). Remove bolts, nuts and washers that hold mounting plate (#37) to stem (#7). Remove mounting plate (#37). (Barrel mount only.)
 - c. Remove intake flange (#13).
NOT APPLICABLE ON ALL MODELS.
 - d. Remove impeller housing (#11).
 - e. Remove impeller retaining screw (#16).
 - f. Remove impeller retaining washer (#18).
 - g. Remove impeller (#12).
 - h. Remove impeller drive key (#19). Tape it to the hub of the impeller so it will not get lost.
 - i. Loosen set screw in slinger (#8).
 - j. Remove stem plate (#41).
NOT APPLICABLE ON ALL MODELS.
 - k. Remove stem (#7).
 - l. Remove ball bearing retainer (#2).
 - m. Slide shaft (#1), telescoping ball bearing housing (#5a), ball bearing (#6), grease and radial bearing retainer (#61) and radial bearing (#4) out of bearing housing (#5) as one unit.
 - n. Remove ball bearing lock nut (#3) from shaft (#1).
 - o. Remove ball bearing (#6) from shaft (#1).
 - p. Remove telescoping ball bearing housing (#5a) from shaft (#1).
 - q. Remove oil seal (#21) from telescoping ball bearing housing (#5a).
 - r. Remove grease and radial ball bearing retainer (#61) and radial ball bearing (#4) together from shaft (#1).
 - s. Remove oil seal (#22) from ball bearing housing (#5).
 - t. Remove throttle bushing retainer (#9).
NOT APPLICABLE ON ALL MODELS.
 - u. Remove throttle bushing (#10).

2. 53VHD & 54VHD chair mount.
 - a. Follow steps in section A.
 - b. Remove 3 bolts (#57). SEE FIG #1.
 - c. Slide shaft (#1), ball bearing retainer (#2), thrust ball bearing (#6) and radial ball bearing (#4) out of ball bearing housing (#5) as one unit.
 - d. Remove ball bearing retainer (#2).
 - e. Slide telescoping ball bearing housing (#5a) down off of the thrust bearing (#6).
 - f. Remove ball bearing housing (#3) from shaft (#1).
 - g. Remove thrust ball bearing (#6) from shaft (#1).
 - h. Slide telescoping ball bearing housing (#5a) off shaft (#1).
 - i. Remove bearing and grease retainer (#61) and radial ball bearing (#4) from shaft (#1). Remove both at the same time so as not to damage retainer.
 - j. Remove oil seal (#21) from telescoping ball bearing housing (#5a).
 - k. Remove oil seal (#22) from ball bearing housing (#5).
 - l. Remove throttle bushing retainer (#9). NOT APPLICABLE ON ALL MODELS.
 - m. Remove throttle bushing (#10).
3. 53VHD & 54VHD barrel mount
 - a. Follow steps in section B.
 - b. Break welds loose that hold discharge pipe cover plate to mounting plate (#37).
 - c. Remove bolts and nuts that hold discharge pipe to impeller housing (#11).
 - d. Remove discharge pipe.
 - e. Remove intake flange (#13). NOT APPLICABLE ON ALL MODELS.
 - f. Remove impeller housing (#11).
 - g. Remove impeller retaining nut (#40).
 - h. Remove impeller retaining washer (#18). NOT APPLICABLE ON ALL MODELS.
 - i. Remove impeller (#12).
 - j. Remove impeller drive key (#19) and tape it to the hub of the impeller so it will not get lost.
 - k. Loosen set screws in slinger (#8).
 - l. Remove stem plate (#41). NOT APPLICABLE ON ALL MODELS.
 - m. Remove stem (#7)
 - n. Remove power frame from mounting plate (#37)
 - o. Remove 3 bolts (#57). SEE FIG #1.
 - p. Slide shaft (#1), ball bearing retainer (#2), thrust ball bearing (#6) and radial ball bearing (#4) out of ball bearing housing (#5) as one unit.

- q. Remove ball bearing retainer (#2).
- r. Slide telescoping ball bearing housing (#5a) down off of the thrust bearing (#6).
- s. Remove ball bearing lock nut (#3) from shaft (#1).
- t. Remove thrust ball bearing (#6) from shaft (#1).
- u. Slide telescoping ball bearing housing (#5a) off shaft (#1).
- v. Remove bearing and grease retainer (#61) and radial ball bearing (#4) from shaft (#1). Remove both at the same time so as not to damage retainer.
- w. Remove oil seal (#21) from telescoping ball bearing housing (#5a).
- x. Remove oil seal (#22) from ball bearing housing (#5).
- y. Remove throttle bushing retainer (#9). NOT APPLICABLE ON ALL MODELS.
- z. Remove throttle bushing (#10).

TO REASSEMBLE PUMP REVERSE THE PROCEDURE USED WHILE MAKING SURE OF THE FOLLOWING.

1. For bearing installation see page 7.
2. Check grease seals (#21) and (#22) for wear. Replace if worn.
3. Install retainer (#61) and telescoping ball bearing housing (#5a) on shaft (#1). Before putting bearing (#6) on shaft (#1).
4. Install slinger (#8) on shaft (#1) while connecting stem (#7) to bearing housing (#5).
5. Check throttle bushing for wear. Replace if worn. There are two different versions of throttle bushings. One is a TEFLON TYPE that has a retainer. The other is a CARBON TYPE that is pressed in place.
6. Clearance between impeller and housing or intake flange should not exceed .015". To adjust clearance see INSTALLATION on page 3, section 5b (for SE models only).

CERTAIN MODELS HAVE AN ENCLOSED IMPELLER. THESE MODELS ARE SUPPLIED WITH A CARBON WEAR RING (#27) THAT IS PRESS FITTED INTO THE INTAKE FLANGE (#13). UPON DISASSEMBLY CHECK THE WEAR RING FOR WEAR. REPLACE IF WORN.

BEARING INSTALLATION

Begin by cleaning your work area thoroughly, contaminants can cause bearing failures as fast as any other reason.

When a bearing is installed, the mounting force should be applied against the ring, and only the ring, which is being press-fitted. A bearing should never be forced onto a shaft by pressure or hammer blows applied to the other ring, nor should the bearing be press-fitted into housing by force allied to the inner ring.

Using an arbor press, the bearing may be laid on a face block which contacts only the bearing inner ring and which has a hole diameter greater than the bearing bore, as shown in FIG. 10. The shaft is pressed through the bearing until it is seated firmly against the shaft shoulder.

If the shaft is not too long, it can be supported beneath the table of the arbor press and the bearing pressed onto it by ram pressure against a piece of soft metal tubing, as shown in FIG. 11. The tubing must be clean, inside and

out, and the diameter of the tubing should be slightly greater than the bearing bore. The end of the tubing should be square (with corners chamfered to avoid flaking) and should contact only the bearing inner ring. The shaft must be held in line with the ram of the arbor press to avoid cocking the bearing on the shaft seat.

When an arbor press is not available, the bearing can be driven onto the shaft seat by light hammer blows against the end of the soft metal tubing. These blows should be made alternately against opposite sides of the tubing face, and great care must be taken to avoid cocking the bearing as it is driven onto the shaft seat.

When a ball bearing is installed into the housing it is normally a slip fit, however if force is necessary to install bearing the force should be exerted on the outer ring of the bearing as shown in FIG. 12. Again the force must be applied evenly so as not to cock the bearing in the bore.

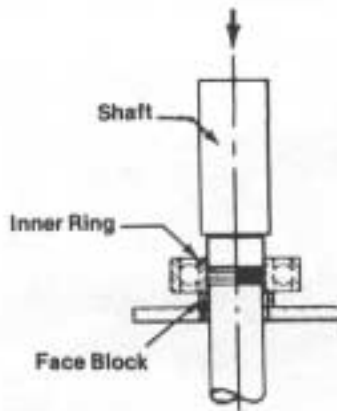

Fig. 10

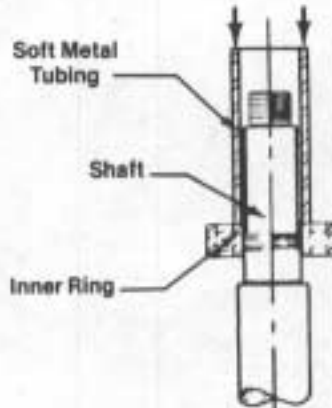

Fig. 11

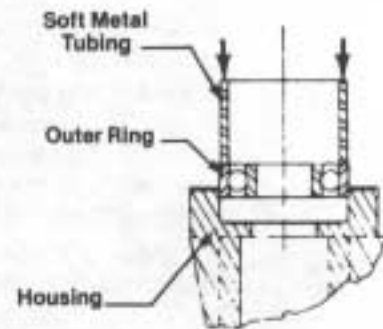

Fig. 12

TROUBLE SHOOTING

NO WATER DELIVERED.

- (1) Pump not primed.
- + (2) Speed too low.
- (3) Discharge head too high.
- (4) Suction line or suction strainer is clogged.
- (5) Impeller completely clogged.
- (6) Wrong direction of rotation.
- (7) Too much clearance between impeller and intake flange.

NOT ENOUGH WATER DELIVERED.

- (1) Air leaks in suction or stuffing boxes.
- + (2) Speed too low.
- (3) Discharge head higher than anticipated.
- (4) Too much clearance between impeller and intake flange.
- (5) Impeller partially clogged.
- (6) Not enough suction head for hot water.
- (7) Mechanical defects:
 - Wear ring is worn.
 - Impeller damaged.
- (8) Impeller diameter too small.
- (9) Foot valve too small.
- (10) Foot valve or suction opening not submerged deep enough.

NOT ENOUGH PRESSURE.

- + (1) Speed too low.
- (2) Air in water.
- (3) Mechanical defects:
 - Wear ring is worn.
 - Impeller damaged.
- (4) Impeller diameter too small.

VIBRATION.

- (1) Bent shaft.
- (2) Pipe strain.
- (3) Impeller clogged.
- (4) Coupling alignment off.

PUMP WORKS FOR A WHILE AND THEN LOSES SUCTION.

- (1) Leaky suction line.
- (2) Water seal plugged.
- (3) Impeller clogged.
- (4) Air or gasses in liquid.

PUMP TAKES TOO MUCH POWER.

- + (1) Speed too high.
- (2) Head lower than rating, pumps too much water.
- (3) Specific gravity or viscosity too high.
- (4) Mechanical defects:
 - Shaft bent.
 - Power frame in bind.
 - Wear ring is worn.
- (5) Impeller diameter too large.
- (6) Pump delivering too many gallons.

+ When directly connected to electric motors, check for full voltage across all electrical leads.

52HD POWER FRAME

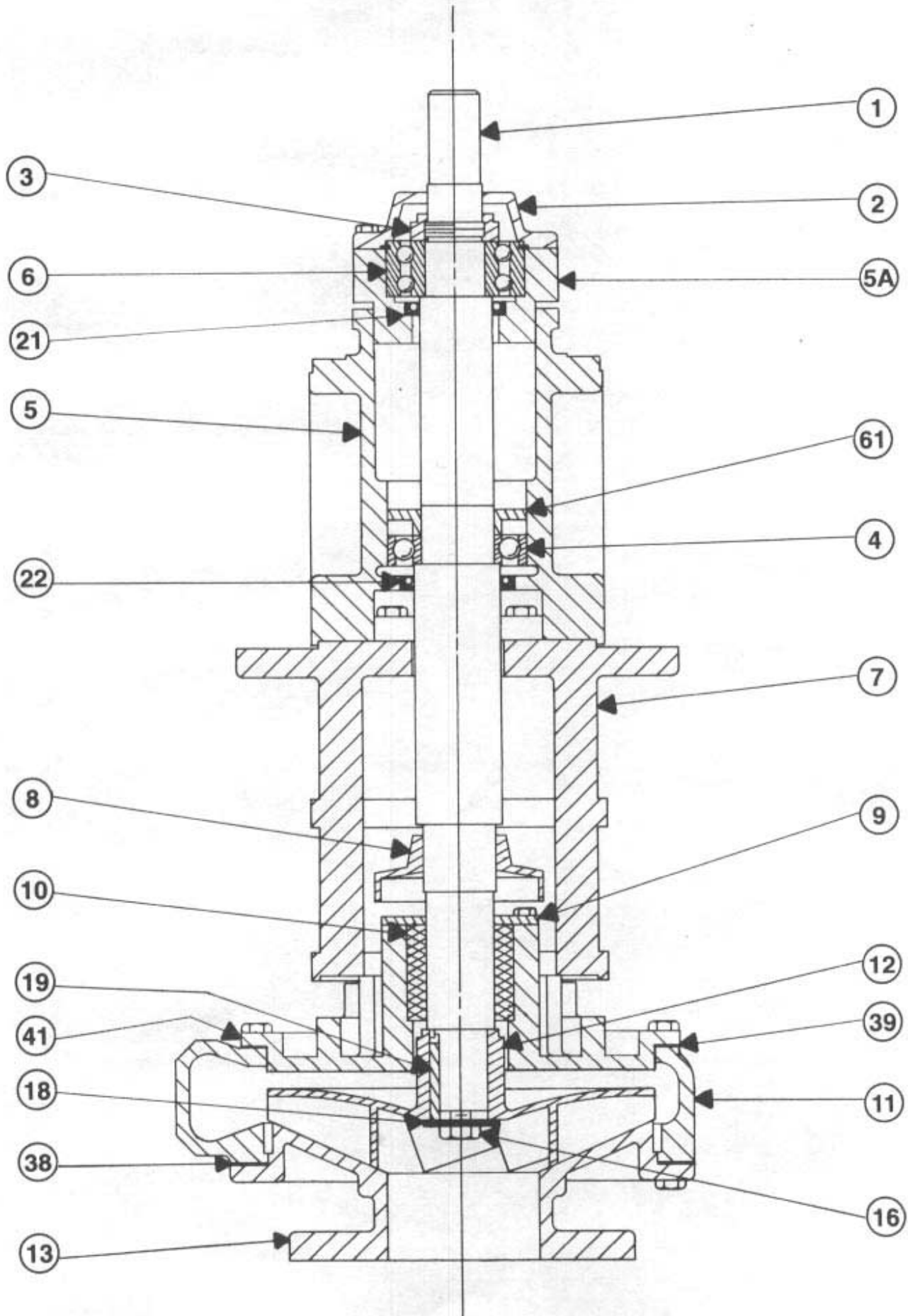

53HD & 54HD POWER FRAME

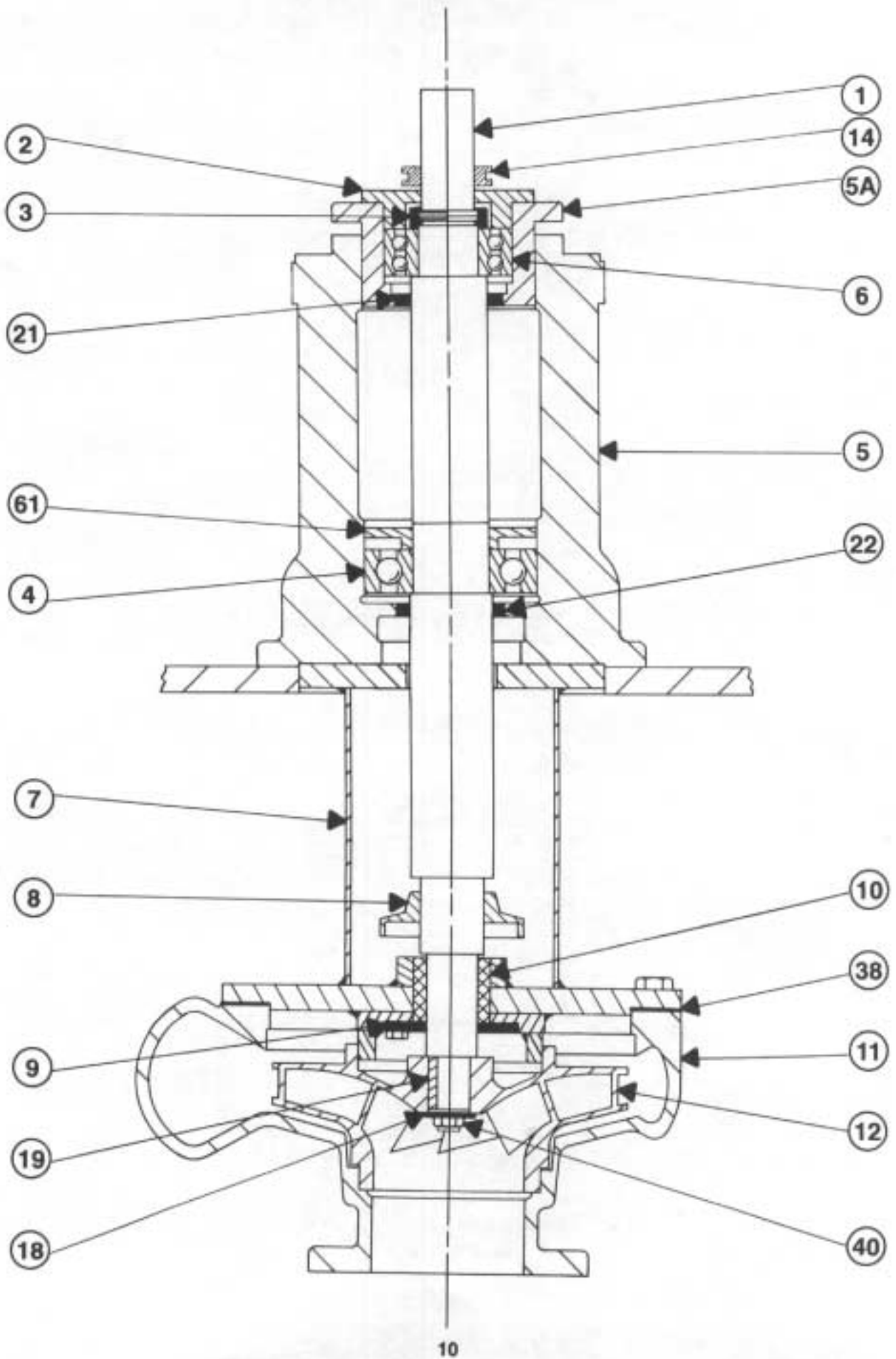

Model	#11 Impeller Housing	#12 Impeller	#13 Intake Flange	#27 Wear Ring	#38 Impeller Hag. Gasket	#39 Stem Pil. Gasket	#41 Stem Plate
1.25X1.5-7	27037	25015	33015	-	61013	61149	21037H
1.5X2-7	27039	25016	33016	-	61013	61149	21037H
2X2.5-7	27041	25017	33017	-	61013	61149	21037H
2.5X3-7	27043	25018	33018	-	61013	61149	21037H
3X4-7	27013	25013	33013	-	61013	-	-
4X5-7	27047	25020	33020	-	61013	61149	21037H
CL-3X4-8	27108A	25108	-	-	61108	-	21108H-4
1.25X1.5-9	27038	25011	33011	-	61011	61011	21038H
5X6-9	27049	25022	33022	-	61011	61011	21038H
1.5X2-10	27040	25009	33009	-	61007	61007	21040H
CL-1.5X3-10	27111A	25111	-	-	61115	-	21111H
2X2.5-10	27042	25010	33010	-	61007	61007	21040H
2.5X3-10	27044	25007	33001	-	61007	61007	21040H
3X4-10	27046	25006	33000	-	61007	61007	21040H
CL-4X6-10	27115A	25115	-	-	61115	-	21220H
5X6-10	27053	25023	33023	65012	61007	61007	21040H
4X5-11	27048	25008	33008	-	61008	61008	21048H
6X8-11	27300-1	25027	-	-	61008	-	21048H-1
CL-1.5X3-13	27116A	25416	-	-	61116	-	21173H
3X4-13	27051-1	25019	33019	65019	61012	61012	21051H
CL-3X4-13	27116A	25116	-	-	61116	-	21140H
4X5-13	27052-1	25021	33021	65019	61012	61012	21051H
CL-4X6-13	27119A	25119	-	-	61116	-	21170H
5X6-13	27154	25012	33012	65012	61012	61012	21051H
CL-6X8-13	27120A	25120	-	-	61116	-	-
6X8-14	27024	25024	-	-	61024	-	-
CL-6X8-15	27122A	25122	-	-	61122	-	-
CL-5X6-16	27141A	25141	-	65141	61141	-	-

Part #	Description	52VHD Power Frame	53VHD Power Frame	53VHD Power Frame 6XB-14E	54VHD Power Frame
1	Shaft	7600HD	100025	100034	100035
2	Ball Brg. Retainer	14003	14083	14083	14082
3	Lock Nut	68100	68100-1	68100-1	68100-2
4	Radial Ball Brg.	41211	41316	41316	41319
5	Ball Brg. Housing	51079	51080	51080	51081
5A	Telescoping Ball Brg. Housing	51019	51083	51083	51082
6	Trust Ball Brg.	41308-DR	41312-DR	41312-DR	41314-DR
8	Slinger	58002	58055	58055	58054
9	Bushing Retainer	71003	71003-1	71024	71091
10	Throttle Bushing (Teflon)	62001	62001-7	62024	62054
10	Throttle Bushing (Carbon)	62001-C	62025	---	62054-C
14	Slinger	---	58053	58053	58071L
16	Impeller Retaining Screw	68015	---	---	---
18	Impeller Retaining Washer	68004	---	---	68024-3
19	Impeller Drive Key	71099	71099-1	71099-1	71099-1
21	Oil Seal	83000	83010	83010	83012
22	Oil Seal	83006	83011	83011	83013
40	Impeller Retaining Nut	---	71213	71213	71213
61	Grease & Radial Brg. Retainer	14079	14080	14080	14081

Model	#7 Stem		
	52VHD	53VHD	54VHD
1.25X1.5-7	17005	17171	-
1.5X2-7	17005	17171	-
2X2.5-7	17005	17171	-
2.5X3-7	17005	17171	-
3X4-7	17005	17171	-
4X5-7	17005	17171	-
CL-3X4-8	17005	17171	-
1.25X1.5-9	17005	17171	-
5X6-9	17005	17171	-
1.5X2-10	17005	17171	-
CL-1.5X3-10	17005	17171	-
2X2.5-10	17005	17171	-
2.5X3-10	17005	17171	-
3X4-10	17005	17171	-
CL-4X6-10	17005	17171	-
5X6-10	17005	17171	-
4X5-11	17005	17171	-
6X8-11	17005	17171	-
CL-1.5-3-13	17005	17171	-
3X4-13	17005	17171	-
CL-3X4-13	17005	17171	-
4X5-13	17005	17171	-
CL-4X6-13	17005	17171	-
5X6-13	17005	17171	-
CL-6X8-13	-	17209	17210
6X8-14	-	17170	17173
CL-6X8-15	-	17265	17261
CL-5X6-16	-	17143	17266

Frequently Used Formulas & Equivalents

HEAD & PRESSURE FORMULA

$$\text{Head in feet} = \frac{(\text{Head in psi}) \times 2.31}{(\text{Sp. Gr.})}$$

$$\text{Head in psi} = \frac{(\text{Head in ft}) \times (\text{Sp. Gr.})}{2.31}$$

NET POSITIVE SUCTION HEAD

Flooded suction: $NPSH = h_a - h_v + h_s - h_f$ Suction lift: $NPSH = h_a - h_v - h_s - h_f$

h_a = the absolute pressure in feet of liquid on the surface of the supply liquid.
 h_v = the vapor pressure of the liquid being pumped expressed in feet of head.
 h_s = the height in feet of the supply liquid surface with respect to the pump inlet.
 h_f = suction line friction losses expressed in feet of head.

These calculations yield the available net positive suction head for a given system. This must be compared to the required net positive suction head $NPSH_R$ calculated by the manufacturer. $NPSH_A$ must exceed $NPSH_R$.

PRESSURE EQUIVALENT TABLE

Convert from	Convert to		Atmospheres	kg/cm ²	kg/m ²	in. water (68°F)	ft. water (68°F)	in. mercury (32°F)	mm mercury (32°F)	Bars †	Mega-Pascals (MPa) †
lb/in ²	1	144	0.068046	0.070307	703.070	27.7278	2.3106	2.03602	51.7150	0.06895	0.006895
lb/ft ²	0.0069444	1	0.000473	0.00488	4.88241	0.1825	0.01605	0.014139	0.35913	0.000479	0.0000479
Atmospheres.....	14.696	2116.22	1	1.0332	10332.27	407.484	33.9570	29.921	760	1.01325	0.101325
kg/cm ²	14.2233	2048.155	0.96794	1.	10000.	394.38	32.8650	28.959	735.558	0.98067	0.098067
kg/in ²	0.01422	0.204768	0.000968	0.0001	1.	0.03944	0.003267	0.002896	0.073558	0.000098	0.0000098
in. water*.....	0.036092	5.1972	0.002454	0.00253	25.375	1.	0.08333	0.073430	1.8651	0.00249	0.000249
ft. water*.....	0.432781	62.3205	0.029449	0.03043	304.275	12.	1.	0.88115	22.3813	0.029839	0.0029839
in. mercury.....	0.491154	70.7282	0.03421	0.03453	345.316	13.6185	1.1349	1.	25.40005	0.033864	0.0033864
mm mercury.....	0.0153368	2.79450	0.0013158	0.0013595	13.59509	0.53616	0.044990	0.03937	1.	0.001333	0.0001333
Bars.....	14.5038	2088.55	0.98692	1.01972	10197.2	402.159	33.5130	29.5300	750.062	1.	0.10
MPa.....	145.038	20885.5	9.8692	10.1972	101972.0	4021.59	335.130	295.300	7500.62	10.0	1.

*Water at 68°F (20°C) 1 mercury at 32°F (0°C) † 1 MPa (MegaPascal) = 10 Bars = 1,000,000 N/m² (Newton/meter²)
 Courtesy of Crane Co. Technical Paper 416.

FLOW EQUIVALENTS

Convert from	Convert to					
	U.S. gal/min.	Imp. gal/min.	U.S. million gal/day	Cu. ft. per sec. (sec.-ft.)	Cu. meters per hour	Liters per sec.
U.S. gal/min.....	1.	0.8327	0.00144	0.00223	0.2271	0.0631
Imp. gal/min.....	1.201	1.	0.00173	0.002676	0.2727	0.0758
U.S. million gal/day.....	694.4	578.25	1.	1.547	157.7	43.8
Cu. ft/sec.....	448.83	373.7	0.646	1.	0.060	28.32
Cu. m/sec.....	15852	13200	22.83	35.35	3600	1000
Cu. m/min.....	264.2	220	0.3804	0.5886	60.0	16.667
Cu. m/hr.....	4.403	3.67	0.00634	0.00982	1	0.2778
Liters/sec.....	15.85	13.20	0.0228	0.0353	3.60	1
Liters/min.....	0.2642	0.220	0.000380	0.000589	0.060	0.0167

VOLUME & WEIGHT EQUIVALENTS

Convert from	Volume and weight equivalents—any liquid						*Weight equivalent basis water at 60°F (15.6°C)		
	U.S. gallons	Imperial gallons	Cubic inches	Cubic feet	Liters	Cubic meters	Pounds	U.S. tons	Kilo-grams
U.S. gallons.....	1.	0.8327	231.	0.13368	3.7854	0.0037854	8.338	0.00417	3.782
Imperial gallons.....	1.20094	1.	277.39	0.16054	4.546	0.004546	10.0134	0.005	4.542
Cubic inches.....	0.004329	0.003605	1.	0.0005787	0.016387	0.00016387	0.036095	55409	0.016372
Cubic feet.....	7.48052	6.229	1728	1.	28.317	0.02832	62.3714	0.03119	28.291
Liters.....	0.2642	0.2200	61.024	0.035315	1.	0.001	2.2029	0.0011	0.1000
Cubic meters.....	264.2	220.0	61024	35.315	1000.	1.	2202.65	1.10133	1000.0
Pounds*.....	0.1199	0.09987	27.71	0.016033	4539	.000454	1.	0.0005	0.45359
U.S. tons*.....	238.87	199.7	55409	32.066	907.9	0.908	2000	1.	907.2
Kilograms*.....	0.2644	0.2202	61.08	0.03534	1.000	.001	2.205	0.0011	1

*Volume and weight equivalents basis water at 60°F (15.6°C); for weights and volumes at other temperatures see page 4-4.

VACUUM PRESSURE EQUIVALENTS

1 atmosphere = 29.92 in Hg = 760mm Hg = 14.7 psi
 1 mm Hg = 1 Torr = (3.937 x 10⁻²) in Hg = 1000µHg = 1.333 milibars
 1 bar = 10⁵ milibars = 10⁶ microbars = 750.06 mm Hg
 1 microbar = 0.75 micron
 1 inch Hg = 2.54 x 10⁴ mm Hg

x in. Hg vacuum = (29.92 - x) in Hg absolute
 y mm Hg vacuum = (760 - y) mm Hg absolute
 z PSIG = (z + 14.7) PSIA
 W PSIA = (w - 14.7) PSIG

GENERAL ENGINEERING DATA

VISCOUS LIQUIDS

CHART II

VISCOSITY MEASURES A LIQUID'S RESISTANCE TO FLOW

VISCOSITY CONVERSION TABLE							
SAYBOLT UNIVERSAL SSU	STOKES	CENTI STOKES	POISES*	CENTI* POISES	ENGLER SECONDS	REDWOOD NO. 1 SECONDS	TYPICAL LIQUIDS AT 70° F
31	.010	1.00	.008	.8	54	29	WATER
35	.025	2.56	.020	2.05	59	32.1	KEROSENE
50	.074	7.40	.059	5.92	80	44.3	NO. 2 FUEL OIL
80	.157	15.7	.126	12.6	125	69.2	NO. 4 FUEL OIL
100	.202	20.2	.162	16.2	150	85.6	TRANSFORMER OIL
200	.432	43.2	.346	34.6	295	170	HYDRAULIC OIL
300	.654	65.4	.522	52.2	470	254	SAE 10W OIL
500	1.10	110	.88	88.0	760	423	SAE 10 OIL
1,000	2.16	220	1.73	173	1,500	896	SAE 20 OIL
2,000	4.40	440	3.52	352	3,000	1,690	SAE 30 OIL
5,000	10.8	1,080	8.80	880	7,500	4,230	SAE 50 OIL
10,000	21.6	2,160	17.0	1,760	15,000	8,460	SAE 60-70 OIL
50,000	108	10,800	88	8,800	75,000	43,660	MOLASSES B
100,000	216	21,600	173	17,300	150,000	88,160	MOLASSES C

*Poises and centipoises are given for oil of .8 spec. Gravity. Relationship: centistokes X specific gravity = centipoises.

PUMPING VISCOUS LIQUIDS WITH CENTRIFUGAL PUMPS

VISCOSITY SSU	30	100	250	500	750	1000	1500	2000
Flow Reduction GPM %	—	3	8	14	19	23	30	40
Head Reduction Feet %	—	2	5	11	14	18	23	30
Horsepower Increase %	—	10	20	30	50	65	85	100

CONVERSION CHART

BARS	x 14.5	=	LBS / SQ. INCH
CELSIUS	= .556 X	(°F - 32)	
CUBIC METRE PER HOUR	x 4.403	=	GALLONS—U.S. PER MINUTE
FAHRENHEIT	= (1.8 x °c)	+ 32	
FEET	x .3048	=	METERS
FEET OF WATER	x .4335	=	LBS / SQ. INCH
GALLONS—IMPERIAL	x 1.20095	=	GALLONS—U.S.
GALLONS—U.S.	x .83267	=	GALLONS—IMPERIAL
GALLONS—U.S.	x 3.785	=	LITRES
GALLONS—U.S. PER MINUTE	x .2271	=	CUBIC METRE PER HOUR
HORSE POWER	x .746	=	KILOWATT
INCHES	x 25.4	=	MILLIMETRES
KILOWATT	x 1.34048	=	HORSE POWER
LITRES	x .2642	=	GALLONS—U.S.
METRES	x 3.281	=	FEET
MILLIMETRES	x .03937	=	INCHES
POUNDS / SQ. INCH	x 2.307	=	FEET OF WATER
POUNDS / SQ. INCH	x .0689	=	BARS

ENGINEERING DATA

CAPACITY AND HEAD IN FEET . . . Gallons per minute (G.P.M.) and Foot heads in the performance charts in this catalog were compiled from actual tests. The Maximum G.P.M. shown is the pump capacity at rated horsepower. The maximum Head in Feet is at full rated speed (60 cycle current). For Maximum G.P.M. all piping should be straight, short and large as possible. Heads and G.P.M. are based on tests with specific gravity of 1 and a temperature of 70°F.

HOW TO FIGURE HEAD . . .

1. Determine static lift (height liquid is to be raised above reservoir)
2. Determine friction loss (losses due to piping depend on size, length and condition of piping system in relation to G.P.M. needed, see table below. Friction losses also include loss due to valves and fittings)
3. Determine velocity head (refer to table below) $V_H = \left(\frac{Vel}{8.02}\right)^2$
4. Total all three of the above and compare to performance chart. Select pump which delivers total head at desired G.P.M.

PIPE FRICTION

Loss of Head in Feet, Per 100 Ft. of 15-year-old Ordinary Iron Pipe Due to Friction.

Gallons per Minute	½" Pipe		¾" Pipe		1" Pipe		1 ¼" Pipe		1 ½" Pipe		2" Pipe		2 ½" Pipe		3" Pipe	
	Vel.	Fric.	Vel.	Fric.	Vel.	Fric.	Vel.	Fric.	Vel.	Fric.	Vel.	Fric.	Vel.	Fric.	Vel.	Fric.
1	1.05	2.1	-----	-----	-----	-----	-----	-----	-----	-----	-----	-----	-----	-----	-----	-----
2	2.10	7.4	1.20	1.9	-----	-----	-----	-----	-----	-----	-----	-----	-----	-----	-----	-----
3	3.16	15.8	1.80	4.1	1.12	1.26	-----	-----	-----	-----	-----	-----	-----	-----	-----	-----
4	4.21	27.0	2.41	7.0	1.49	2.14	0.86	0.57	0.63	0.26	-----	-----	-----	-----	-----	-----
5	5.26	41.0	3.01	10.5	1.86	3.25	1.07	0.84	0.79	0.39	-----	-----	-----	-----	-----	-----
10	10.52	167.0	6.02	38.0	3.72	11.7	2.14	3.05	1.57	1.43	1.02	0.5	0.65	0.17	0.45	0.07
15	-----	-----	9.02	80.0	5.60	25.0	3.2	6.5	2.36	3.0	1.53	1.0	0.98	0.36	0.68	0.15
20	-----	-----	12.03	136.0	7.44	42.0	4.29	11.1	-----	-----	-----	1.83	1.31	0.61	0.91	0.25
25	-----	-----	-----	-----	9.30	64.9	5.36	16.6	3.94	7.8	3.55	2.73	1.63	0.92	1.13	0.38
30	-----	-----	-----	-----	11.15	89.0	6.43	23.5	4.72	11.0	3.06	3.84	1.96	1.29	1.36	0.54
35	-----	-----	-----	-----	13.02	119.0	7.51	31.2	5.51	14.7	3.57	5.1	2.20	1.72	1.59	0.71
40	-----	-----	-----	-----	14.88	152.0	8.58	40.0	6.3	18.8	4.08	6.6	2.61	2.20	1.82	0.91
45	-----	-----	-----	-----	-----	-----	9.65	50.	7.08	23.3	4.60	8.2	3.94	2.80	2.05	1.15
50	-----	-----	-----	-----	-----	-----	10.72	60.	7.87	28.4	5.11	9.9	3.27	3.32	2.27	1.38
70	-----	-----	-----	-----	-----	-----	15.01	113.	11.02	53.0	7.15	18.4	4.58	6.2	3.18	2.57
90	-----	-----	-----	-----	-----	-----	-----	-----	14.17	84.0	9.19	29.4	5.88	9.8	4.09	4.08
100	-----	-----	-----	-----	-----	-----	-----	-----	15.74	102.0	10.21	35.8	6.54	12.0	4.54	4.96
120	-----	-----	-----	-----	-----	-----	-----	-----	18.89	143.0	12.25	50.0	7.84	16.8	5.45	7.0
140	-----	-----	-----	-----	-----	-----	-----	-----	22.04	190.0	14.30	67.0	9.15	22.3	6.35	9.2
160	-----	-----	-----	-----	-----	-----	-----	-----	-----	-----	16.34	86.0	10.46	29.0	7.26	11.8
180	-----	-----	-----	-----	-----	-----	-----	-----	-----	-----	18.38	107.0	11.76	35.7	8.17	14.8
200	-----	-----	-----	-----	-----	-----	-----	-----	-----	-----	20.42	129.0	13.07	43.1	9.08	17.8
220	-----	-----	-----	-----	-----	-----	-----	-----	-----	-----	22.47	154.0	14.38	52.0	9.99	21.3
240	-----	-----	-----	-----	-----	-----	-----	-----	-----	-----	24.51	182.0	15.69	61.0	10.89	25.1
260	-----	-----	-----	-----	-----	-----	-----	-----	-----	-----	26.55	211.0	16.99	70.0	11.80	29.1
280	-----	-----	-----	-----	-----	-----	-----	-----	-----	-----	-----	-----	18.30	81.0	12.71	33.4
300	-----	-----	-----	-----	-----	-----	-----	-----	-----	-----	-----	-----	19.61	92.0	13.62	38.0

Friction of Water in 90° Elbows

Size of Elbow, inches	½"	¾"	1"	1 ¼"	1 ½"	2"	2 ½"	3"	4"	5"	6"
Friction Equivalent Feet Straight Pipe	5	6	6	8	8	8	11	15	16	18	18

To Compute Break Horse Power

$$BHP = \frac{GPM \times H \times S.G.}{3960 \times \text{pump Eff.}^*}$$

S.G. = Specific Gravity,

BHP = Break Horse Power,

GPM = Gallons per Minute,

H = Head in Feet

Eff. = Efficiency

Horse Power and Pressure (PSI) vary in direct proportion to the Specific Gravity.

Effect of Speed Changes

1. Capacity (GPM) is directly proportional to the change in speed.
2. Head is proportional to the square of the change in speed.
3. Horse Power is proportional to the cube of the change in speed.

Pipe Friction (Continued)

Loss of Head in Feet, Per 100 Ft. of 15-year-old Ordinary Iron Pipe Due to Friction.

Gallons per Minute	4" Pipe		5" Pipe		6" Pipe	
	Vel.	Fric.	Vel.	Fric.	Vel.	Fric.
40	1.02	0.22	-----	-----	-----	-----
45	1.17	0.28	-----	-----	-----	-----
50	1.28	0.34	-----	-----	-----	-----
75	1.79	0.63	1.14	0.21	-----	-----
75	1.92	0.73	1.22	0.24	-----	-----
100	2.55	1.23	1.63	0.39	1.14	0.14
120	3.06	1.71	1.96	0.57	1.42	0.25
123	3.19	1.86	2.04	0.64	1.48	0.28
150	3.84	2.35	2.43	0.86	1.71	0.32
175	4.43	3.26	2.86	1.18	2.00	0.48
200	5.11	4.37	3.27	1.48	2.28	0.62
225	6.32	6.61	3.67	1.86	2.57	0.74
250	6.40	6.72	4.08	2.34	2.80	0.92
275	7.03	7.99	4.50	2.73	3.06	1.15
300	7.66	9.38	4.90	3.15	3.40	1.29
350	8.90	12.32	5.72	4.19	3.96	1.69
400	10.20	15.82	6.54	5.33	4.54	2.21
450	11.50	19.74	7.35	6.65	5.12	2.74
475	12.30	22.96	7.88	7.32	5.55	3.21
500	12.77	24.08	8.17	8.12	5.60	3.26
550	-----	-----	9.09	9.66	6.16	3.93
600	-----	-----	9.80	11.34	6.72	4.70
650	-----	-----	10.63	13.16	7.28	5.60
700	-----	-----	11.44	15.12	7.84	6.38
750	-----	-----	12.36	17.22	8.50	7.00
800	-----	-----	-----	-----	9.08	7.90
850	-----	-----	-----	-----	9.58	8.75
900	-----	-----	-----	-----	10.20	10.11
950	-----	-----	-----	-----	10.72	10.71
1000	-----	-----	-----	-----	11.32	12.04
1100	-----	-----	-----	-----	12.50	14.31
1200	-----	-----	-----	-----	13.52	16.89

THEORETICAL DISCHARGE OF NOZZLES IN U. S. GALLONS PER MINUTE

HEAD		Velocity of Discharge Feet Per Second	DIAMETER OF NOZZLE IN INCHES								
Pounds	Feet		1/8	1/4	3/8	1/2	5/8	3/4	7/8	1	
10	23.1	38.6	0.37	1.48	3.32	5.91	13.3	23.6	36.9	53.1	72.4
15	34.6	47.25	0.45	1.84	4.06	7.24	16.3	26.9	45.2	65.0	88.5
20	46.2	54.55	0.52	2.09	4.69	8.35	18.8	33.4	52.2	75.1	102
25	57.7	61.0	0.58	2.34	5.25	9.34	21.0	37.3	58.3	84.0	114
30	69.3	66.85	0.64	2.56	5.75	10.2	23.0	40.9	63.9	92.0	125
35	80.8	72.2	0.69	2.77	6.21	11.1	24.8	44.2	69.0	99.5	135
40	92.4	77.2	0.74	2.96	6.64	11.8	26.6	47.3	73.8	106	145
45	103.9	81.8	0.78	3.13	7.03	12.5	28.2	50.1	78.2	113	153
50	115.5	86.25	0.83	3.30	7.41	13.2	29.7	52.8	82.5	119	162
55	127.0	90.4	0.87	3.46	7.77	13.8	31.1	55.3	86.4	125	169
60	138.6	94.5	0.90	3.62	8.12	14.5	32.5	57.8	90.4	130	177
65	150.1	98.3	0.94	3.77	8.45	15.1	33.8	60.2	94.0	136	184
70	161.7	102.1	0.98	3.91	8.78	15.7	35.2	62.5	97.7	141	191
75	173.2	105.7	1.01	4.05	9.08	16.2	36.4	64.7	101	146	198
80	184.8	109.1	1.05	4.18	9.39	16.7	37.6	66.8	104	150	205
85	196.3	112.5	1.08	4.31	9.67	17.3	38.8	68.9	108	155	211
90	207.9	115.8	1.11	4.43	9.95	17.7	39.9	70.8	111	160	217
95	219.4	119.0	1.14	4.56	10.2	18.2	41.0	72.8	114	164	223
100	230.9	122.0	1.17	4.67	10.0	18.7	42.1	74.7	117	168	229
105	242.4	125.0	1.20	4.79	10.8	19.2	43.1	76.5	120	172	234
110	254.0	128.0	1.23	4.90	11.0	19.8	44.1	78.4	122	176	240
115	265.5	130.9	1.25	5.01	11.2	20.0	45.1	80.1	125	180	245
120	277.1	133.7	1.28	5.12	11.5	20.5	46.0	81.8	128	184	251
125	288.6	136.4	1.31	5.22	11.7	20.9	47.0	83.5	130	188	256
130	300.2	139.1	1.33	5.33	12.0	21.3	48.0	85.2	133	192	261
135	311.7	141.8	1.36	5.43	12.2	21.7	48.9	86.7	136	195	266
140	323.3	144.3	1.38	5.53	12.4	22.1	49.8	88.4	138	199	271
145	334.8	146.9	1.41	5.62	12.6	22.5	50.6	89.9	140	202	275
150	346.4	149.5	1.43	5.72	12.9	22.9	51.5	91.5	143	206	280
175	404.1	161.4	1.55	6.16	13.9	24.7	55.6	98.8	154	222	302
200	461.9	172.6	1.65	6.61	14.8	26.4	59.5	106	165	238	323

HEAD		Velocity of Discharge Feet Per Second	DIAMETER OF NOZZLE IN INCHES								
Pounds	Feet		1	1 1/4	1 1/2	1 3/4	1 7/8	2	2 1/4	2 1/2	
10	23.1	38.6	94.5	120	148	179	213	289	378	479	591
15	34.6	47.25	116	147	181	219	260	354	463	585	723
20	46.2	54.55	134	169	209	253	301	409	535	676	835
25	57.7	61.0	149	189	234	283	336	458	598	756	934
30	69.3	66.85	164	207	256	309	368	501	655	828	1023
35	80.8	72.2	177	224	277	334	398	541	708	895	1106
40	92.4	77.2	188	239	296	357	425	578	756	957	1182
45	103.9	81.8	200	253	313	379	451	613	801	1015	1252
50	115.5	86.25	211	267	330	399	475	647	845	1070	1320
55	127.0	90.0	221	280	346	418	498	678	886	1121	1365
60	138.6	94.5	231	293	362	438	521	708	926	1172	1447
65	150.1	98.3	241	305	376	455	542	737	964	1220	1506
70	161.7	102.1	250	317	391	473	563	765	1001	1267	1565
75	173.2	105.7	259	327	404	489	582	792	1037	1310	1619
80	184.8	109.1	267	338	418	505	602	818	1010	1354	1672
85	196.3	112.5	276	349	431	521	620	844	1103	1395	1723
90	207.9	115.8	284	359	443	536	638	868	1136	1436	1773
95	219.4	119.0	292	369	456	551	656	892	1168	1476	1824
100	230.9	122.0	299	378	467	565	672	915	1196	1512	1870
105	242.4	125.0	306	388	479	579	689	937	1226	1550	1916
110	254.0	128.0	314	397	490	593	705	960	1255	1588	1961
115	265.5	130.9	320	406	501	606	720	980	1282	1621	2005
120	277.1	133.7	327	414	512	619	736	1002	1310	1639	2050
125	288.6	136.4	334	423	522	632	751	1022	1338	1690	2090
130	300.2	139.1	341	432	533	645	767	1043	1365	1726	2132
135	311.7	141.8	347	439	543	656	780	1063	1390	1759	2173
140	323.3	144.3	354	448	553	668	795	1082	1415	1790	2212
145	334.8	146.9	360	455	562	680	809	1100	1400	1820	2250
150	346.4	149.5	366	463	572	692	824	1120	1466	1853	2290
175	404.1	161.4	395	500	618	747	890	1210	1582	2000	2473
200	461.9	172.6	423	535	660	799	950	1294	1691	2140	2645

NOTE—The actual quantities will vary from these figures, the amount of variation depending upon the shape of nozzle and size of pipe at the point where the pressure is determined. With smooth taper nozzles the actual discharge is about 94 per cent of the figures given in the labels.

MAINTENANCE HISTORY

SERIAL NO. _____
 MODEL NO. _____ IMP. DIA. _____
 OPERATING COND. _____ GPM @ _____ FT. THD
 HP. _____ SPEED/RPM _____
 Start-Up Date _____ Amps at Start-Up _____
 Pressure at Start-Up _____

ENGINEERING DATA

POWER FRAME	52HD	53HD	54HD
1. RADIAL BRG.	41211	41316	41319
2. THRUST BRG.	41308-DR	41312-DR	41314-DR
3. BALL BRG. SPAN	9.032	12.750	12.750
4. SHAFT DIA'S.			
@ RADIAL BRG.	2.1655	3.1497	3.7403
@ THRUST BRG.	1.5750	2.3623	2.7560
@ THROTTLE BUSHING	1.735	1.875*	2.500
@ IMPELLER	1.375	1.500	1.750
BET. BALL BRG'S.	1.937	3.125	3.625
BET. RADIAL BRG. & THROTTLE SLV.	2.250	3.250	4.250

*2.010 (6x6-14)

GREASE LUBRICATION

DATE	GREASED	DATE	GREASED	DATE	GREASED

TYPE GREASE USED _____

COUPLING ALIGNMENT

Parallel Alignment

Angular Alignment

Date Checked	Amt. Out	Date Checked	Amt. Out	Date Checked	Amt. Out	Date Checked	Amt. Out	Date Checked	Amt. Out	Date Checked	Amt. Out

NOTES: _____

Product Profile

SEVERE DUTY CENTRIFUGAL SEPARATOR

MODEL # SDS SERIES SEPARATOR

PRODUCT FEATURES

THE EBBCO SDS CENTRIFUGAL SEPARATORS ARE DESIGNED TO REMOVE SOLIDS FROM LIQUIDS. EACH MODEL IS SIZED BASED UPON THE FLOW RATE.

UPON TANGENTIAL ENTRY, THE LIQUID AND SOLIDS ARE DRAWN THROUGH INTERNAL SLOTS AND ACCELERATE INTO THE SEPARATION CHAMBER. SOLIDS THAT ARE HEAVIER THAN THE CARRYING LIQUID ARE SEPARATED AND ACCUMULATED IN THE COLLECTION CHAMBER. THE SOLIDS ARE PERIODICALLY PURGED INTO A COLLECTION VESSEL. CLEAN LIQUID IS DRAWN UP AND OUT OF THE SEPARATOR

- NO MOVING PARTS TO WEAR OUT.
- LOW PRESSURE LOSS.
- NO BACKFLUSHING.
- NO DOWNTIME REQUIREMENTS.
- NO SCREENS, CARTRIDGES, CONES, OR FILTER ELEMENTS TO CLEAN OR REPLACE.
- FLOW RATES FROM 45-1200 GPM

PROVEN APPLICATIONS

- ABRASIVE WATERJET-GARNET REMOVAL.
- PARTS WASHERS.
- HEAT TREATMENT SYSTEMS.
- MACHINE TOOL COOLANT FILTRATION.



FLOW vs PRESSURE LOSS

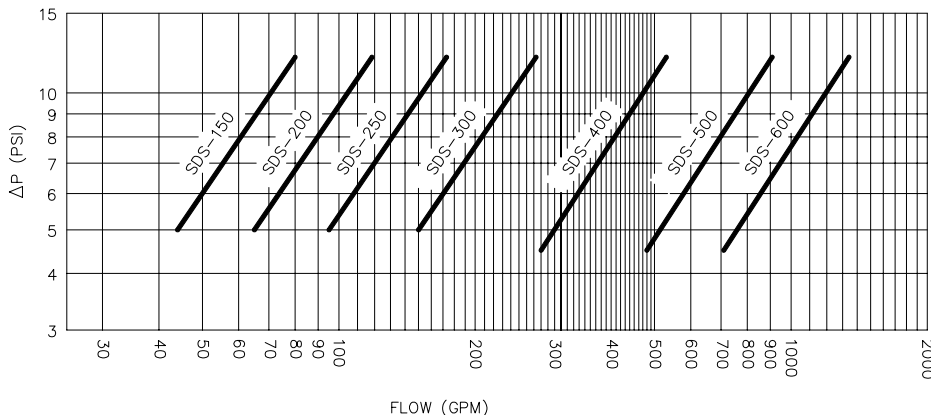

Ebbco inc.

METALWORKING FILTRATION & FLUIDS

THIS IS A PROPRIETARY DOCUMENT OF EBBCO, INC.

www.ebbcoinc.com

Specifications

SEVERE DUTY CENTRIFUGAL SEPARATOR

MODEL # SDS SERIES SEPARATOR

MAX PRESSURE	150 psi
PRESSURE LOSS RANGE	5-12 psi
FLOW RANGE	45-1200 gpm
MAX PARTICLE SIZE	3/8"
MATL OF CON.	CARBON STEEL (STAINLESS STEEL OPTIONAL)

*CONSULT FACTORY FOR HIGHER FLOW RATES AND OPERATING PRESSURES

CAUTION: FOR USE WITH A CENTRIFUGAL PUMP ONLY! DO NOT USE WITH A POSITIVE DISPLACEMENT PUMP.

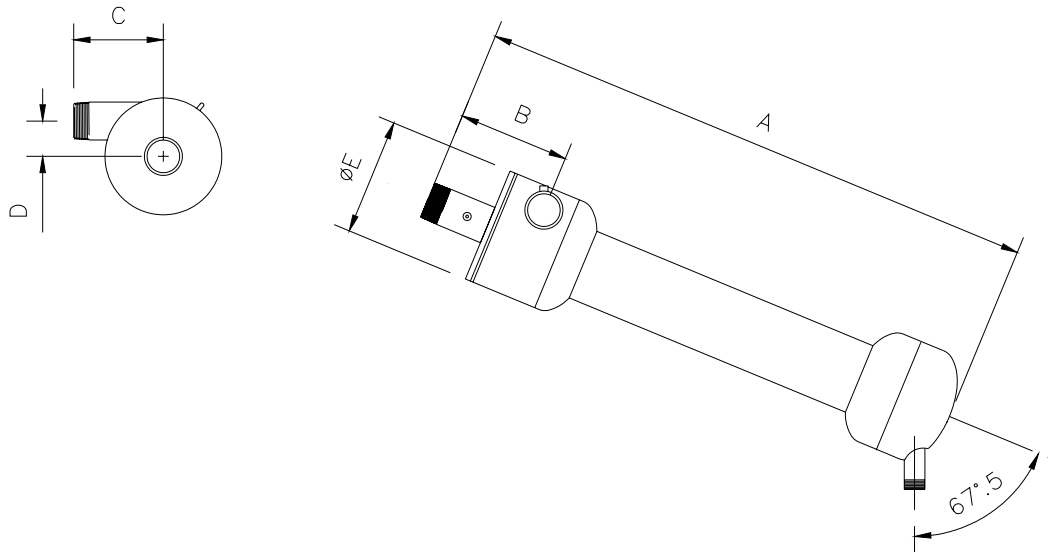

MODEL	A	B	C	D	E	FLOW RANGE	INLET/OUTLET	PURGE SIZE	WEIGHT DRY	WEIGHT WET
0150-B	30	4 ³ / ₈	4 ³ / ₄	1 ³ / ₄	6	45-70	1 1/2"	1 1/2"	27	40
0200-B	33 ⁵ / ₈	5	5 ¹ / ₂	2 ⁵ / ₈	8 ⁵ / ₈	65-108	2"	1 1/2"	52	98
0250-B	37	5 ¹ / ₂	6 ¹ / ₄	2 ⁵ / ₈	8 ⁵ / ₈	98-155	2 1/2"	1 1/2"	60	109
0300-B	42	7	8 ¹ / ₄	3 ¹ / ₄	10 ³ / ₄	148-290	3"	1 1/2"	101	177
0400-B	88	14 ¹ / ₂	10	3 1/8	11	275-550	4"	1 1/2"	300	410
0500-B	108	16 ¹ / ₄	12	3 11/16	11	480-880	6"	1 1/2"	415	615
0600-B	108	16 ¹ / ₄	12	3 11/16	11	720-1200	6"	1 1/2"	475	714

ALL DIMENSION (") ALL FLOW IN (USGPM)

Product Profile

TANK EDUCTORS

TO KEEP UNWANTED SOLIDS FROM SETTLING IN A SUMP, EBBCO EDUCTORS PROVIDE A VENTURI ACTION, WHICH AMPLIFIES THE INPUT FLOW RATE TO SWEEP SOLIDS TOWARDS THE PUMP INTAKE.

- HELPS TO AVOID TROUBLESOME ACCUMULATION
- REDUCES MAINTENANCE AND SHUTDOWN ROUTINES
- PROTECTS PUMPS AND PROCESS FLUID SYSTEMS FROM FOULING AND/OR ABRASIVE WEAR FROM UNWANTED SOLIDS
- MINIMIZES BACTERIAL GROWTH, BROUGHT ON OTHERWISE BY SOLIDS ACCUMULATION
- LIMITS THE NEED FOR CHEMICAL TREATMENTS TO CONTROL BACTERIAL & ALGAE BT PREVENTING SOLIDS BUILD UP

ABLE TO OPERATE AT LOW PRESSURES AND IN LOW SUBMURGANCE. EBBCO EDUCTORS MULTIPLY THE FLOW RATE BY A FACTOR OF FOUR OR FIVE ENABLING THE USE OF A SMALLER PUMP TO REDUCE ENERGY COSTS. COMPACT IN DESIGN, DURABLE AND EASY TO INSTALL.

MALT OF CONST.

PDVF (KYNAR), 316 SS, GLASS FILLED PP, CAST IRON

MODEL No	10	15	20	25	30	35	40
	NOZZLE FLOW (US GPM)						
0MP	7.5	9.2	10.7	11.9	13.1	14.1	15
2MP	13.5	17	19	21	23	25	27

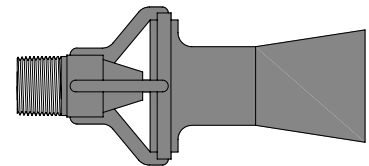

OMP

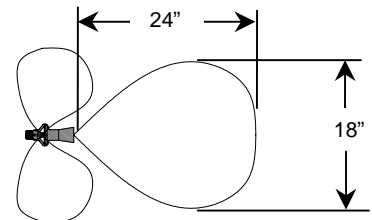

2MP

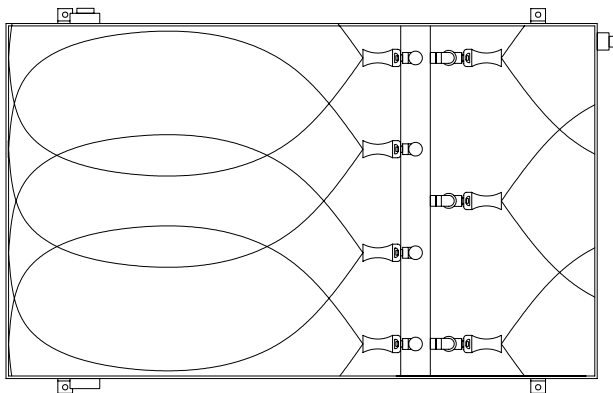
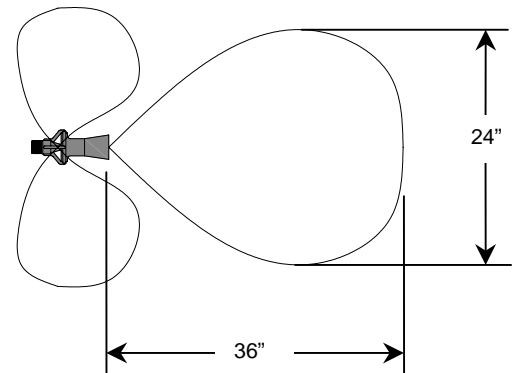

Ebbco inc.

METALWORKING FILTRATION & FLUIDS



www.ebbcoinc.com

Product Profile

Abrasive Bag Hopper

MODEL # GRS-ABH



Description:

The Ebbco one cu.yd. Abrasive Bag Hopper is designed to capture up to 4000 lb. of garnet. Spent garnet that is discharge from the centrifugal separator is collected into the Abrasive Bag Hopper. The heavy garnet settles to the bottom of the Abrasive Bag Hopper and begins to de-water itself. The excess fluid that is purged into the Abrasive Bag Hopper flows out of the collection bag and decants back to the catch tank. The Abrasive Bag Hopper is constructed from 1/4" carbon steel plate.

- Dimensions: 36"L x 36"W x 48"H
- Material of cont.: Carbon Steel
- Finish: Industrial enamel paint
- Dry Weight 580 lb.

System Features & Benefits:

- Clean and easy system for handling spent abrasive.
- Spent abrasive is bagged and ready for recycling or reclamation.
- Rouged construction.
- Clean out ports.
- Fork truck access.

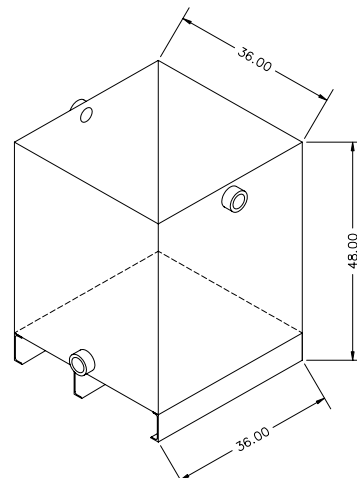

THIS IS A PROPRIETARY DOCUMENT
OF EBBCO, INC

Ebbco inc.

METALWORKING FILTRATION & FLUIDS

www.ebbcoinc.com

EBBCO REF J-8259

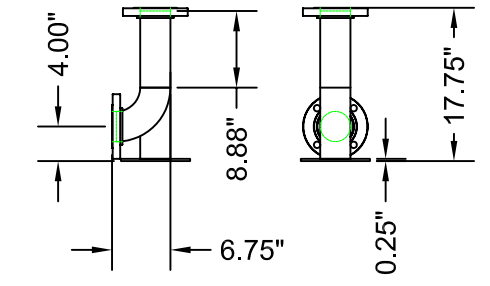
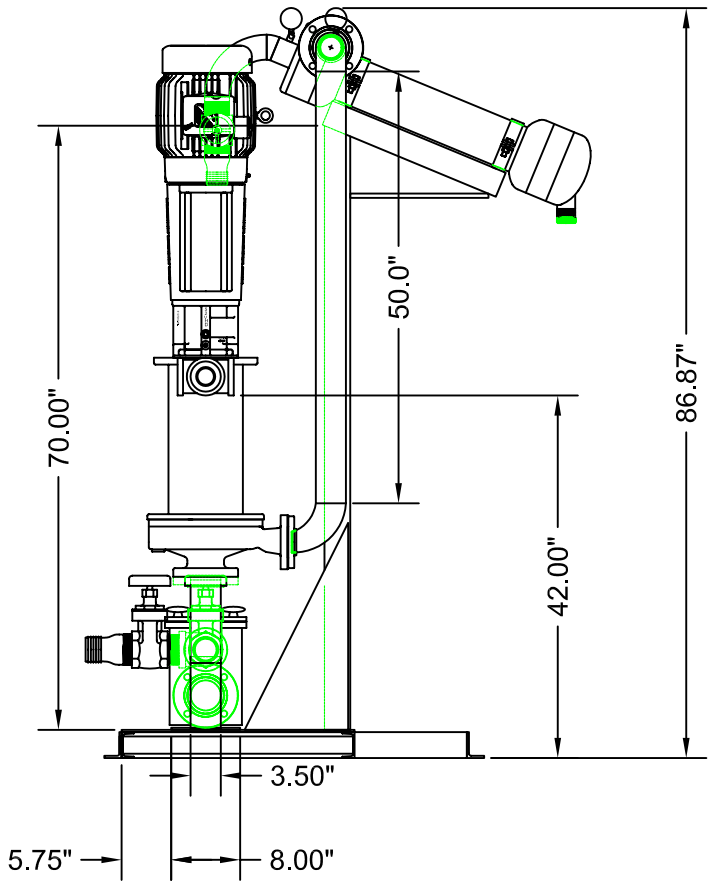
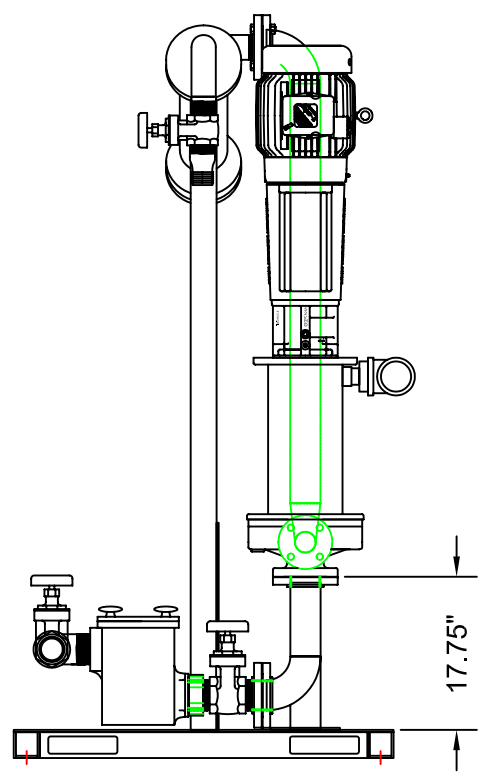
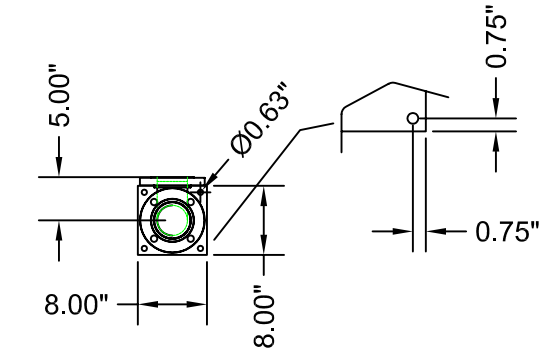
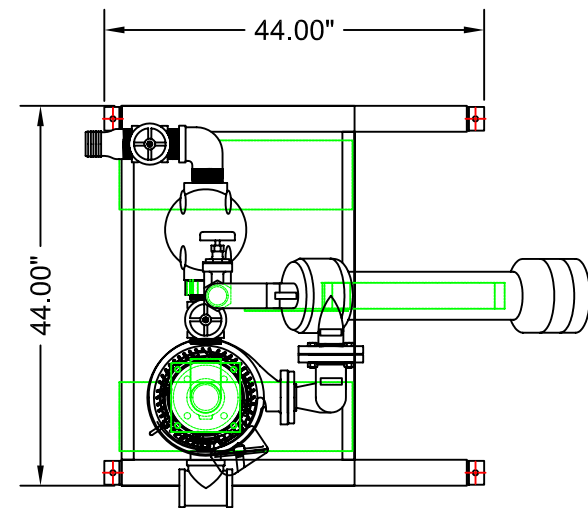

<small>THIS DOCUMENT IS PROPRIETARY. NO DISCLOSURE, REPRODUCTION OR USE OF ANY PART THEREOF MAY BE MADE WITHOUT THE EXPRESS WRITTEN PERMISSION OF EBBCO INC. CUSTOMER</small>					51536 Industrial Dr New Baltimore, MI 48047 (586) 716-5151 Fax (586) 716-4949
TOLERANCES DIMENSIONS UNLESS SPECIFIED UNLESS OTHERWISE SPECIFIED FRACTIONS DECIMALS ANGLES .X .XX .XXX .4 .5 .6 .7 .8 .9 .00 .01 .02 .03 .04 .05 .06 .07 .08 .09 .10 .15 .20 .25 .30 .35 .40 .45 .50 .60 .70 .80 .90 .000 .001 .002 .003 .004 .005 .006 .007 .008 .009 .010 .015 .020 .025 .030 .035 .040 .045 .050 .060 .070 .080 .090 .100 .150 .200 .250 .300 .350 .400 .450 .500 .600 .700 .800 .900	JOB NUMBER J-8259	PART NUMBER	DRAWN BY T.W.K.	DATE 12/11/08	TITLE GRS-0250-B-CC-
THIRD ANGLE PROJECTION PRINT STATUS	CHECKED BY	DATE	INIT REL APPR BY	DATE	SIZE W-2208-108-001
					SCALE SHEET 1 of 1

EBBCO REF J-8259

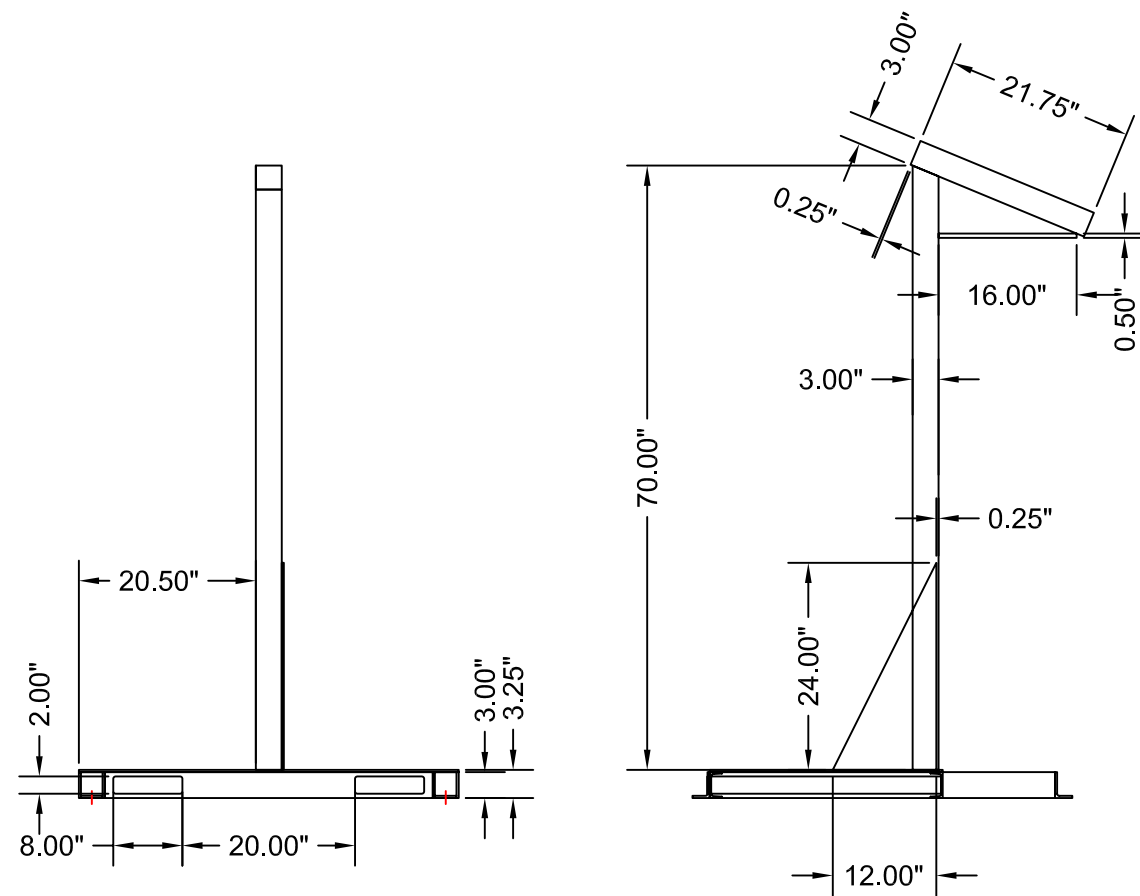
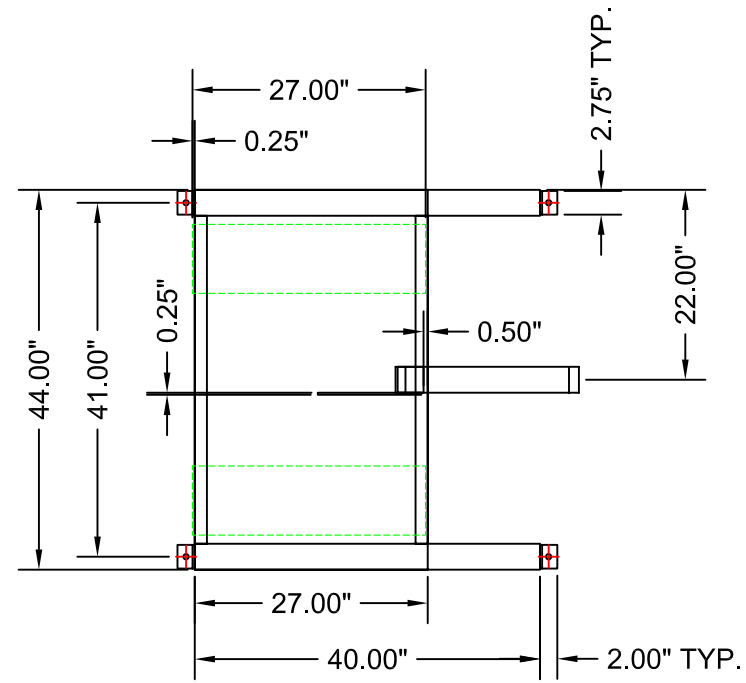

THIS DOCUMENT IS PROPRIETARY. NO DISCLOSURE, REPRODUCTION OR USE OF ANY PART THEREOF MAY BE MADE WITHOUT THE EXPRESSED WRITTEN PERMISSION OF EBBCO INC.

CUSTOMER		JOB NUMBER		PART NUMBER		 51536 Industrial Dr New Baltimore, MI 48047 (586)716-5151 Fax(586)716-4949	
DIMENSIONS UNLESS SPECIFIED UNLESS OTHERWISE SPECIFIED FRACTIONS DECIMALS ANGLES 1/8" 0.125" 30°		J-8259					
DRAWN BY		DATE		TITLE		GRS-0250-B-CC-	
T.W.K.		12/11/08					
CHECKED BY		DATE		SIZE		DRAWING NUMBER	
				W-2208-108-002		ENS	
INIT REL APPR BY		DATE		SCALE		SHEET 1 of 1	

THIRD ANGLE PROJECTION

EBBCO REF J-8259

230VAC 3 PH 60HZ

PROVIDE MAXIMUM
UPSTREAM PROTECTION
PER NEC CODE
430-52 AND TABLE
430-152

L1 L2 L3

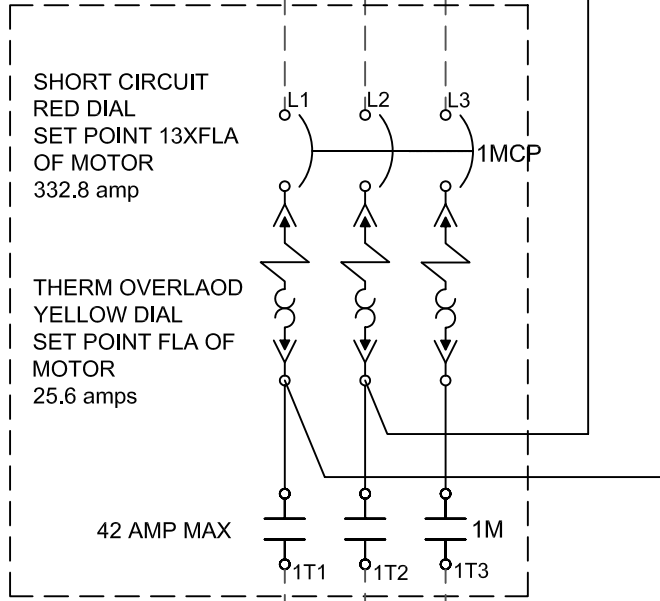

BLACK BLACK BLACK

1MTR

FILTER PUMP
230VAC 3 PH 60HZ
10 HP TEFC
21.0 FLA
RPM 1755

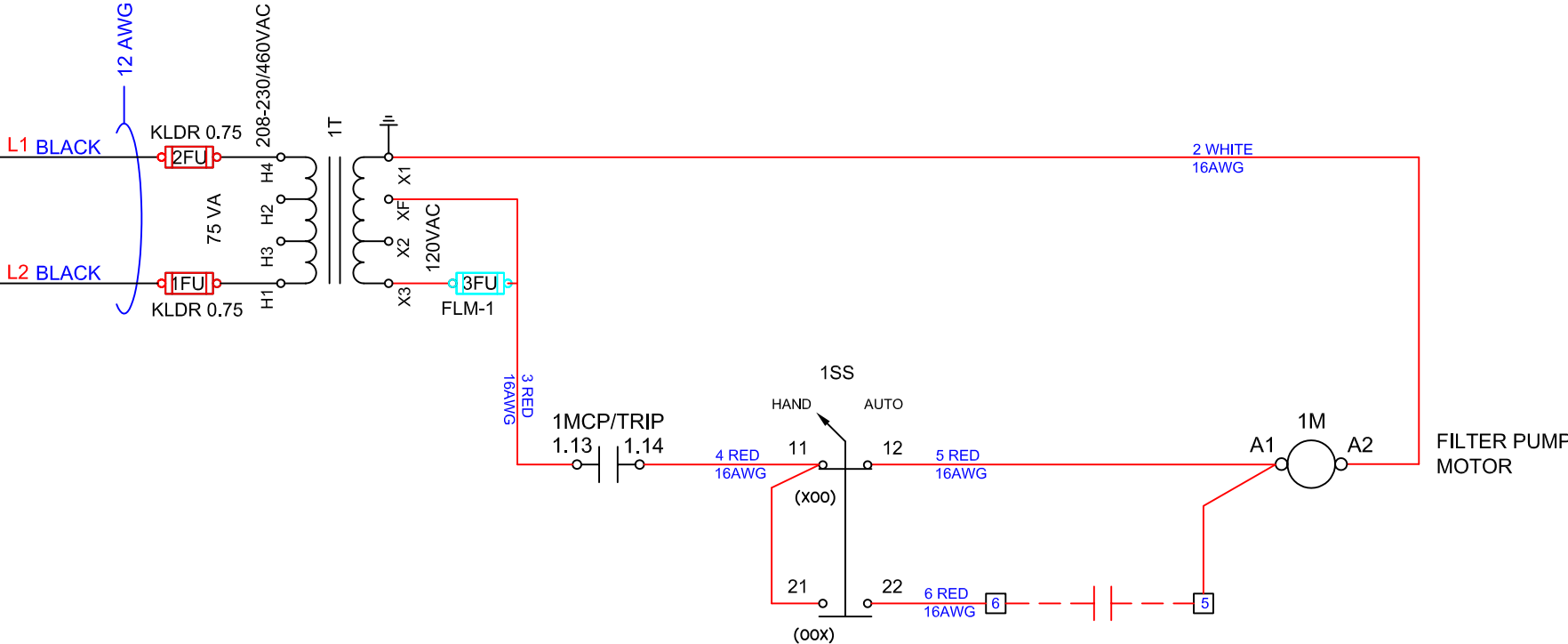

THIS DRAWING HAS BEEN GENERATED AND IS MAINTAINED BY A CAD SYSTEM. PAPER COPIES ARE UNCONTROLLED.

<small>THIS DOCUMENT IS PROPRIETARY. NO DISCLOSURE, REPRODUCTION OR USE OF ANY PART THEREOF MAY BE MADE WITHOUT THE EXPRESS WRITTEN PERMISSION OF EBBCO INC.</small>		EBBCO inc. 51536 Industrial Dr New Baltimore, MI 48047 (586)716-5151 Fax(586)716-4949	
CUSTOMER: MC MACHINERY		JOB NUMBER:	PART NUMBER:
TOLERANCES: DIMENSIONS UNLESS OTHERWISE SPECIFIED FRACTIONS DECIMALS ANGLES .0001" .0001" .0001"	DRAWN BY: JPG	DATE: 11/20/08	TITLE: GARNET REMOVAL SYSTEM ELECTRICAL SCHEMATIC GRS-0250-B-CC-MC
THIRD ANGLE PROJECTION	CHECKED BY:	DATE:	SIZE: E-2208-108-001
PRINT STATUS:	INIT REL APPR BY:	DATE:	SHEET 1 of 1



EBBCO REF

REV	ZONE	REVISION HISTORY	DATE	APP'D
0		FIRST ISSUE	11/25/08	JPG

ITEM	QTY	DESCRIPTION	MATERIAL	Part List	DRN REF	PART #	VENDOR	NOTE
1	2	3" -1.5" REDUCER BUSHING	PVC SCH 80				EBBCO	
2	2	3" TOE NIPPLE	PVC SCH 80				EBBCO	
3	1	3" 90 ELBOW	PVC SHD 80				EBBCO	
4	1	3" STRAIGHT TEE	PVC SCH 80				EBBCO	
5	4	1.5" 90 ELBOW	PVC SCH 80				EBBCO	SLIPxSLIP
6	12	1 1/2" STRAIGHT TEE	PVC SCH 80				EBBCO	EF-1.50-TE-P8-SS
7	12	3/8" EDUCTOR	POLYPROPYLENE				EBBCO	OMP
8	6	1" - 3/8" REDUCER BUSHING	PVC SCH 80				EBBCO	EF-1.00-0.375-RB-P8-TT
9	12	1 1/2" -1" REDUCER BUSHING	PVC SCH 80				EBBCO	EF-1.50-1.00-RB-P8-ST
10	6	1" TOE NIPPLE	PVC SCH 80				EBBCO	EBF-1.00-NO-P8
11	6	1" - 3/8" REDUCER BUSHING	PVC SCH 80				EBBCO	EF-1.00-0.375-RB-P8-ST
12	6	1" 45 ELBOW	PVC SCH 80				EBBCO	EF-1.00-E4-P8-SS
13	1	3" HOSE BARB	STEEL				EBBCO	
14	1	2.5" HOSE BARB	STEEL				EBBCO	
17	1	2.5" CLOSE NIPPLE	CARBON STEEL				EBBCO	
18	1	2.5" GATE VALVE	BRASS				EBBCO	
19	1	3" - 2.5" REDUCING BUSH	CAST IRON			EF-3.00-2.50-RB-CI-TT	EBBCO	
20	2	3" BOLH HEAD FITTING	PP				EBBCO	
21	1	3" 45 ELBOW	PVC SCH 80				EBBCO	SLIPxSLIP

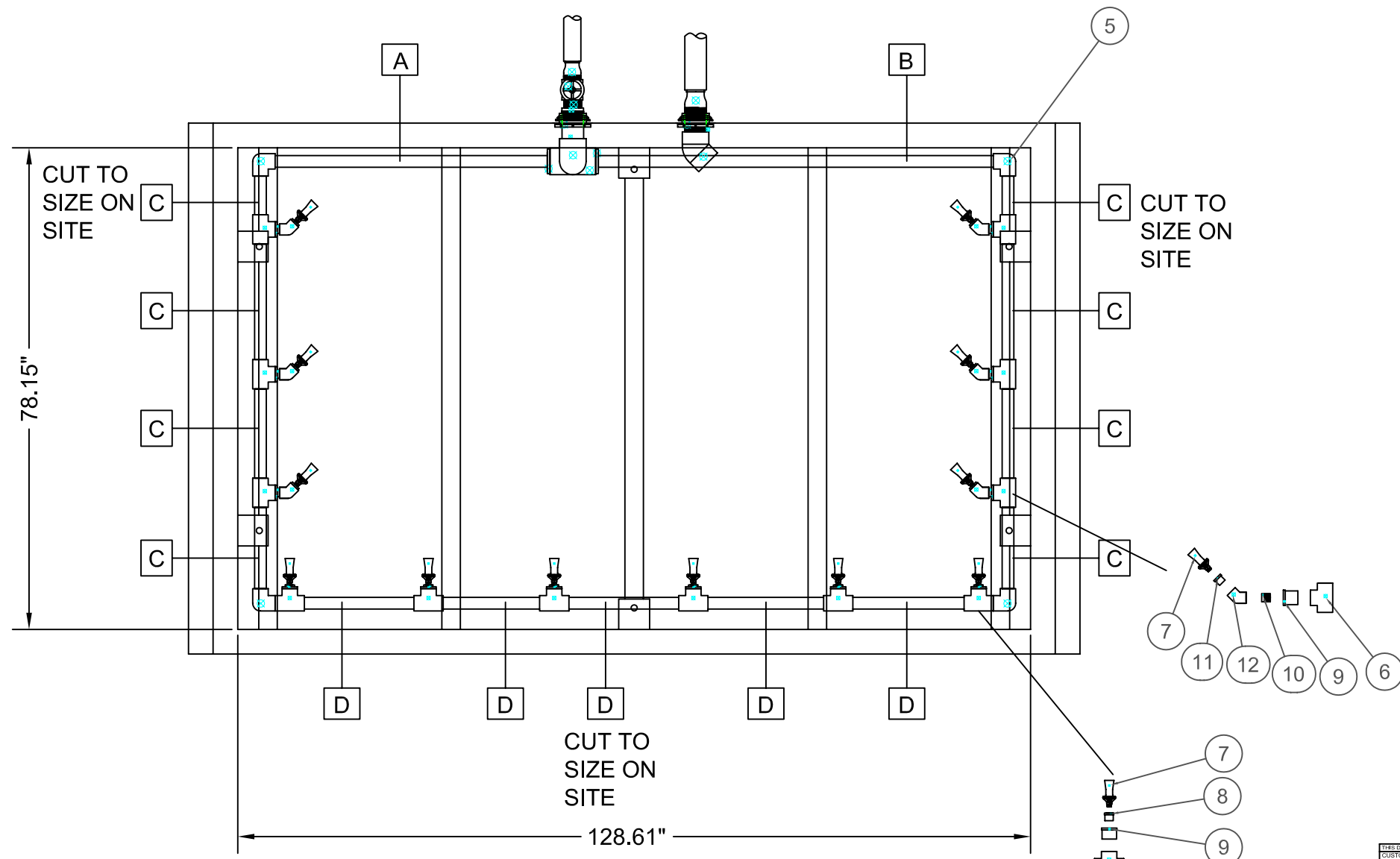
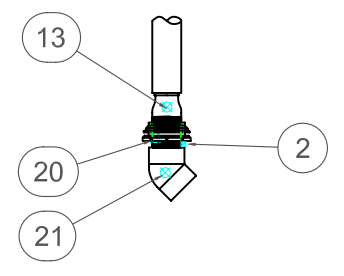
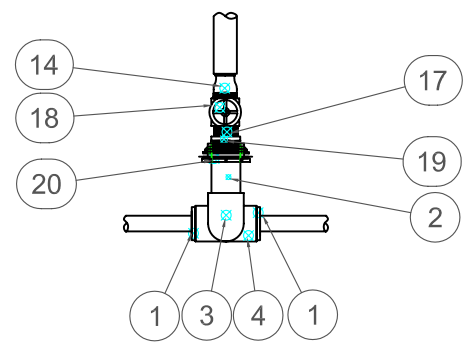

PVC PIPE CUT LIST		
ITEM	QTY	LENGHT
A	1	72"
B	1	84"
C	8	16"
D	5	20"

NOTES:

1. ASSEMBLE THREADED FITTINGS WITH PIPE DOPE AND TIGHTEN. CLEAN AND GLUE SLIP FITTINGS AS DESCRIBED BELOW. PIPE DOPE, CLEANER, AND CEMENT ARE INCLUDED.

IMPORTANT

CORRECT GLUING PROCEDURE:

1. PRIME BOTH THE PIPE AND FITTING SOCKET TO BE JOINED.
2. IMMEDIATELY APPLY A COAT OF CEMENT TO THE PIPE.
3. APPLY A LIGHT COAT OF CEMENT TO THE FITTING.
4. ADD A SECOND COAT OF CEMENT TO THE PIPE.
5. PUSH THE PARTS TOGETHER, ENSURING THAT THE PIPE IS FULL DEPTH OF SOCKET ROTATING 1/8" TO 1/4", AND HOLD FOR 15 - 30 SECONDS.

DO NOT IGNORE THE PROPER SEQUENCE OF APPLYING THE PRIMER AND CEMENT. IT IS EXTREMELY IMPORTANT WHEN YOU ASSEMBLE ANY PVC SCHEDULE 80 FITTINGS.

KEY:
[X] ASSEMBLY REFERENCE TAG

THIS DRAWING HAS BEEN GENERATED AND IS MAINTAINED BY A CAD SYSTEM. PAPER COPIES ARE UNCONTROLLED.

<small>THIS DOCUMENT IS PROPRIETARY. NO DISCLOSURE, REPRODUCTION OR USE OF ANY PART THEREOF MAY BE MADE WITHOUT THE EXPRESS WRITTEN PERMISSION OF EBBCO INC. CUSTOMER</small>		MC MACHINERY	Ebbco inc.
<small>DESIGNER</small> <small>UNLESS OTHERWISE SPECIFIED</small>	<small>JOB NUMBER</small> <small>PART NUMBER</small>	<small>DATE</small> 11/25/08	51536 Industrial Dr New Baltimore, MI 48047 (586)716-5151 Fax(586)716-4949
<small>DATE</small> 11/25/08	<small>DATE</small> 11/25/08	<small>TITLE</small> GRS-0250-B-CC SWEEPER PACKAGE DRAWING	<small>SCALE</small> S-2208-108-001
<small>THIRD ANGLE PROJECTION</small>	<small>SCALE</small>	<small>SIZE</small> S-2208-108-001	<small>END</small> SHEET 1 of 1

DANGER

FOLLOW PROPER LOCKOUT PROCEDURE BEFORE SERVICING THIS EQUIPMENT.

DANGER

GARNET REMOVAL INSTALLATION REGISTRATION AND ACCEPTANCE FORM

1. System is positioned properly.
2. Sweeper package has been installed according to drawing provided by Ebbco.
3. All external connections have been made between Garnet Removal System and waterjet catch tank; and proper air supply has been hooked up to plant air minimum 80 PSI @ 2 SCFM.
4. System runs with a 4 to 10 PSI pressure differential between inlet and outlet of separator.*
5. Good water movement in waterjet catcher tank.
6. System runs with no leaks.
7. Purge is set for a four (4) second purge every 60 seconds; water should flow back from the Garnet Hopper to the waterjet cutting tank.*
8. Customer understands how system works and how to service the strainer basket.
9. Customer knows how, and when, to empty spent Garnet Hopper.*
10. Overflow baffle is installed in Garnet Hopper.*
11. Use only Ebbco certified consumables and replacement parts. Failure to do so may cause catastrophic failure.
12. System is designed to run simultaneously with waterjet. Always run your Garnet Removal System while you cut.

***Note: Item numbers 4, 7, 9, and 10 must be followed and maintained or warranty is null and void.**

Failure to follow above instructions can lead to catastrophic failure of the Ebbco Garnet Removal System as well as poor performance. The Garnet Removal System has been installed and is operating correctly according to the service manual. I have read and understand the Ebbco Service Manual. I agree that proper system maintenance and filter change out will be adhered to.

OPERATING PRESSURES		
Inlet	Outlet	Vac

Ebbco Technician (if on site)

Company

Supervisor

Contact Name

Operator

Contact Phone Number

Operator

Contact E-Mail Address

INSTALL DATE: _____

SERIAL NO: _____

NOTE: Warranty on equipment is null and void if this form is not completed and returned to Ebbco upon installation. Email to: customerservice@ahbinc.com