

Product Profile

Abrasive Removal System

Application 31 -72 Square Feet

Recommended Model: GRS-0250B-CC-SL



Product Description:

Ebbco's Abrasive Removal System is designed to continuously remove the spent abrasive that collects in the catch tank, thus eliminating downtime for clean out and maximizes production. The Abrasive Removal can be retrofitted to any Abrasive Waterjet Cutting machine tool.

System Benefits:

- Maximizes Productivity
- Eliminates Downtime for Catch Tank Cleaning
- Reduces the Possibility of Thermal Distortion
- Reduces Closed Loop Consumable Costs
- Full One Year Warranty on Pump & System



Abrasive Receiver Options:

The Ebbco Abrasive Removal System comes with a choice of three abrasive receivers. A 55 Gallon Drum or the Ebbco Abrasive Bag Hopper.



Patent Applied For

Specifications

Abrasive Removal System

Model # GRS-0250B-CC-SL

System:

Dimensions: 66" L X 44"w
Voltage Requirements 220v / 460v 3 Phase
Full Load Amp 27/15

Inlet / Outlet :

Suction 3"
Discharge 2.5"

Pump/Motor:

Hp 10
Rpm 1800
Fla 25.6/12.8 (220/460)
Suction Pipe Size 3"
Discharge Pipe Size 2"

Separator:

Model: SDS-0250-B
Inlet/Outlet Size 3"/2.5"
Purge Size 1"

Suction Basket

Heavy Duty Carbon Steel Housing For Pump Protection. Internal Stainless Steel Removable Basket for Ease of Service.

Sweeper Package:

The Sweeper Package Incorporates a 4 to 1 Eductor System, Which Enhances Water Flow and Keeps the Garnet in Suspension, Pushing it Toward the Pumps Suction.

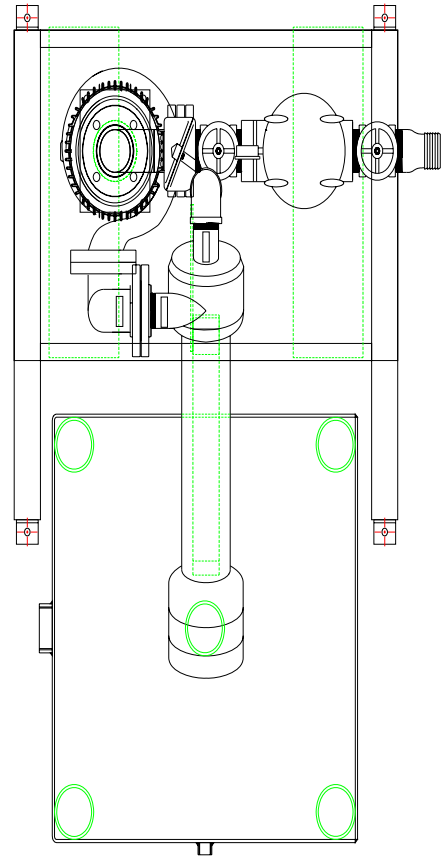

**COMPLETE
METALWORKING
SOLUTIONS**

(800) 991-4225
www.ahbinc.com
ISO Certified
customerservice@ahbinc.com

