

FACILITY REQUIREMENTS	
MAIN SYSTEM	
AIR	538L/MIN (19SCFM) @ 6.9-8.3 BAR (100-120 PSI) FOR Z-AXIS END EFFECTOR AND (OPTIONAL) WATER LEVEL CONTROL ADDITIONAL 538 L/MIN (19 SCFM) INTERMITTENT REQUIRED PER Z-AXIS END EFFECTOR FOR (OPTIONAL) ULTRAPIERCE VACCUM ASSIST
WATER	7.6 L/MIN (2 GPM) @ 4.1 BAR (60 PSI)
CATCHER	
DRAIN	1" NPT GRAVITY DRAIN
ABRASIVE BULK TRANSFER (ABT)	
AIR	SEE ABT PRE-INSTALL DRAWING FOR REQUIREMENTS
PUMP	
AIR	SEE PUMP PRE-INSTALL DRAWING FOR REQUIREMENTS
WATER	
POWER	
ELECTRICAL REQUIREMENTS	
3-PHASE VOLTAGE/FREQUENCY	MAIN CIRCUIT BREAKER SIZE
480 VAC - 60 HZ	25 AMP
400 VAC - 50 HZ	25 AMP

NOTES:

- 101 RECOMMENDED CLEARANCE FOR MACHINE ACCESS AND MAINTENANCE IS 1000 MM (39"). ACTUAL DISTANCE TO BE DETERMINED BY LOCAL CODES/REGULATIONS.
- 102 SEE PUMP PRE-INSTALL DRAWING FOR SIZE AND REQUIREMENTS
- 103 UTILITIES DROPS FOR AIR, WATER, AND POWER LOCATION ARE APPROXIMATED. DROPS MUST NOT INTERFERE WITH LIGHT CURTAIN SIGNAL (IF EQUIPPED).
- 104 LOCATION SHOWN FOR REFERENCE. ABT CAN BE LOCATED WITHIN CABLE AND HOSE LIMITS. EXTENSION KITS ARE AVAILABLE FOR ALTERNATE LOCATIONS IF REQUIRED. SEE ABT PRE-INSTALL DRAWING FOR SIZE AND REQUIREMENTS.
- 105 INSTALLATION TYPICAL OUTSIDE LIGHT CURTAIN BOUNDARY, FINAL LOCATION TO BE DETERMINED AT TIME OF INSTALL.
- 106 RECOMMENDED CLEARANCE FOR ACCESS AND SAFETY AROUND THE ABT (ABRASIVE BULK TRANSFER) UNIT IS 1000 MM (39")

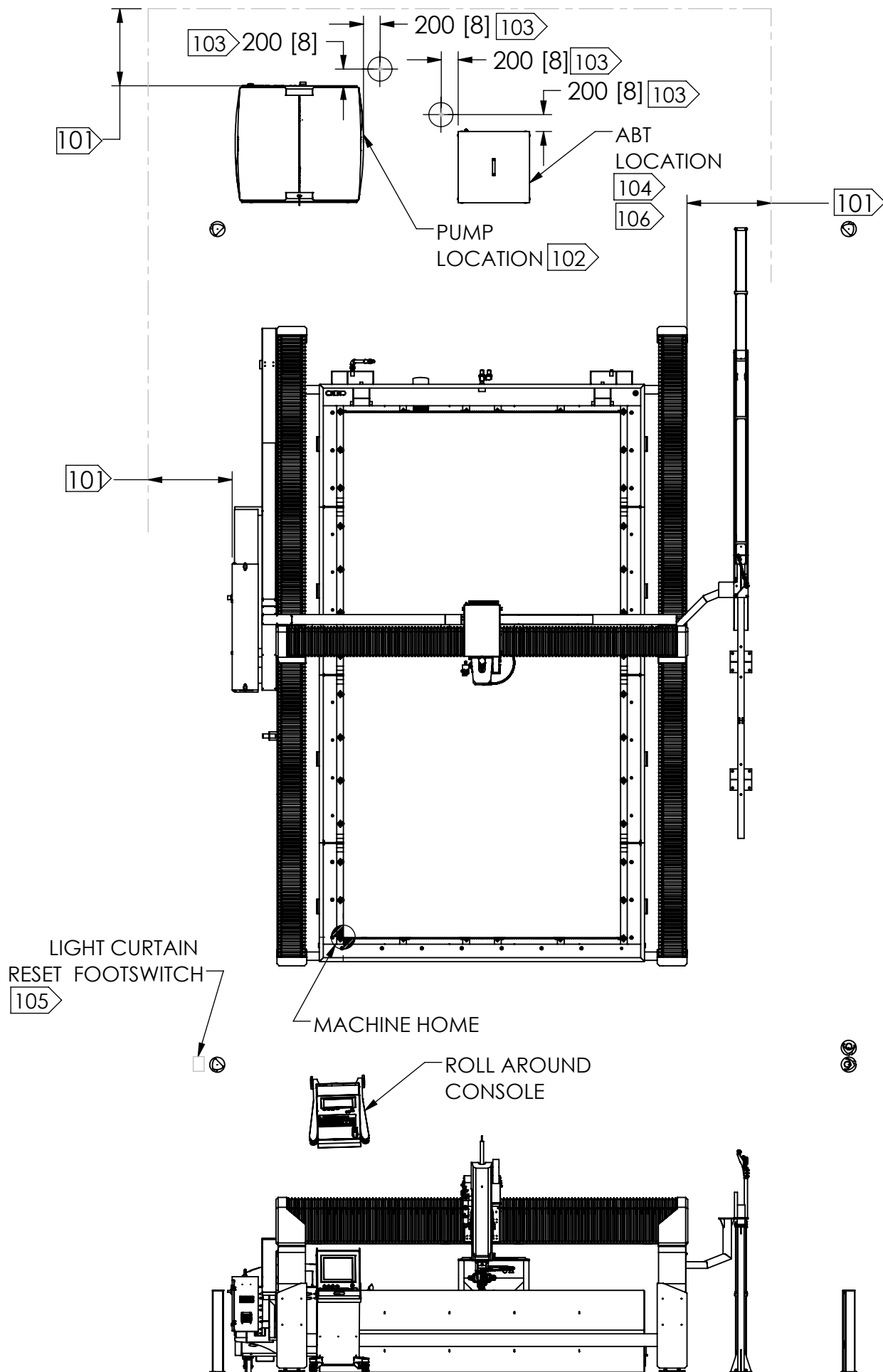

- LEGEND**
- MACHINE HOME
 - UTILITY DROP

DIMENSIONS ARE IN MILLIMETERS, DIMENSIONS IN BRACKETS ARE IN INCHES.

THIRD ANGLE PROJECTION		THIS DRAWING IS THE PROPERTY OF FLOW INTERNATIONAL CORPORATION AND IS NOT TO BE COPIED OR REPRODUCED WITHOUT THE WRITTEN CONSENT OF FLOW INTERNATIONAL CORPORATION.		
MATERIAL				
DRAWN BY J.OROVA	STARTED 11/10/2016	ENG J.HOPKINS	EST WEIGHT N/A	MODELED IN SOLIDWORKS
TITLE PRE-INSTALL;M500;3060				
REVISION 02	SCALE 1:64	BASE PART NUMBER	059874	1 OF 3

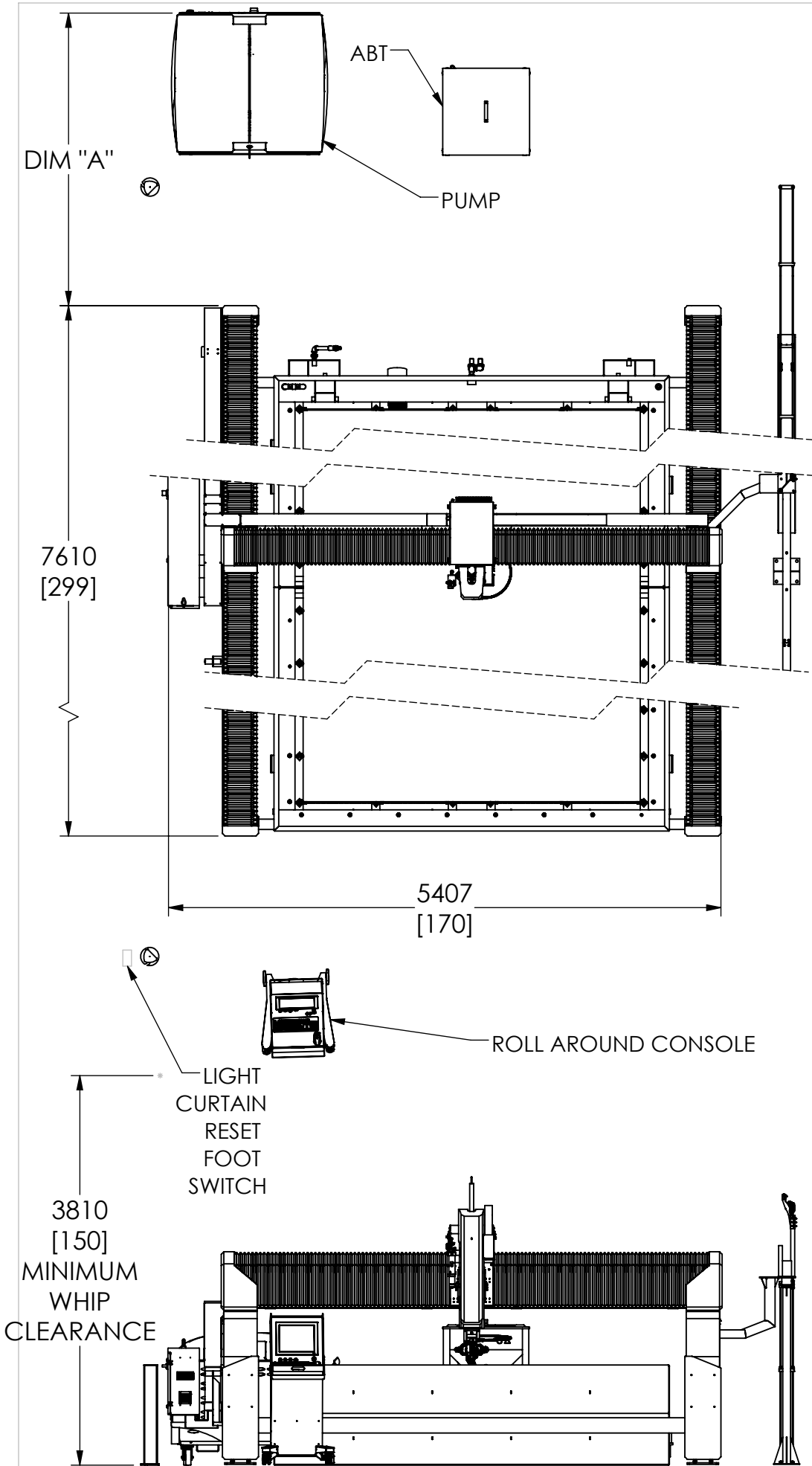

NOTES:

- 201 LOCATION OF ANCHORS TO BE DETERMINED ONCE MACHINE HAS BEEN SET AND LEVELED
- 202 SEE PRE-INSTALLATION GUIDE FOR FOUNDATION REQUIREMENTS.
- 203 LIGHT CURTAIN BOUNDARY DIMENSIONS TAKEN FROM THE FARTHEST LEFT/RIGHT MOVING PART OF BRIDGE RISERS (INCLUDING UHP), FRONT OF CATCHER TANK, AND REAR OF BRIDGE AT MAXIMUM EXTENT OF TRAVEL REARWARD. 2500MM (98.4") MINIMUM FROM CUTTING AREA FOR XD WRIST CONFIGURATIONS. 1200MM (47.3") MINIMUM TO ANY MOVING PART OF GANTRY IN GENERAL AND FOR ALL NON-XD CONFIGURATIONS.

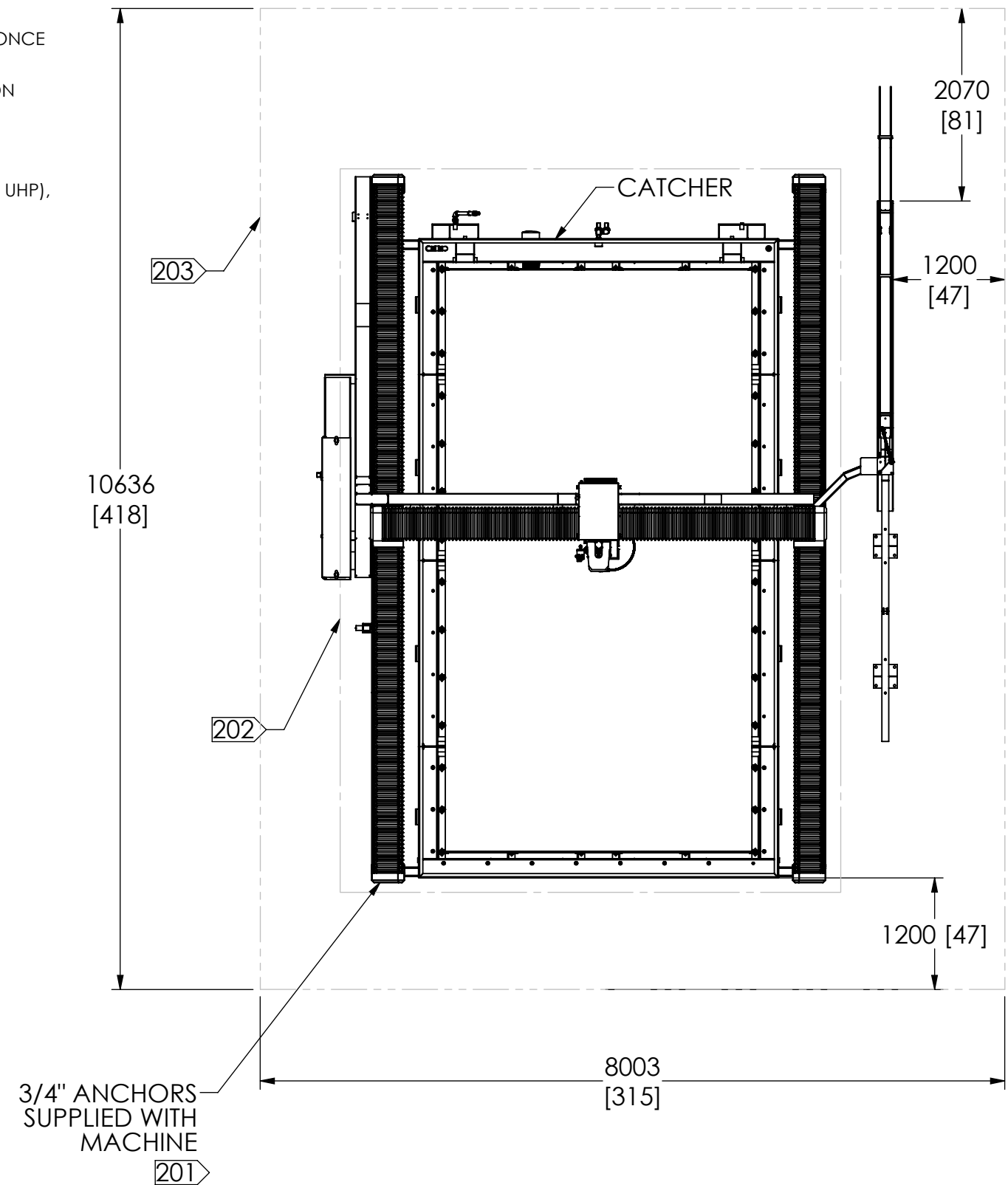

DIM "A"	
WITH LIGHT CURTAIN	3500 [137]
WITHOUT LIGHT CURTAIN	2600 [102]

THIRD ANGLE PROJECTION			THIS DRAWING IS THE PROPERTY OF FLOW INTERNATIONAL CORPORATION AND IS NOT TO BE COPIED OR REPRODUCED WITHOUT THE WRITTEN CONSENT OF FLOW INTERNATIONAL CORPORATION.		
	MATERIAL				
DRAWN BY J.OROVA	STARTED 11/10/2016	ENG J.HOPKINS	EST WEIGHT N/A	MODELED IN SOLIDWORKS	
TITLE PRE-INSTALL;M500;3060					
REVISION 02	SCALE 1:55	BASE PART NUMBER	059874		2 OF 3

NOTE:

301 J8 (RJ45 CONNECTOR) IS RESERVED FOR CUSTOMER ETHERNET.
 DISTANCE AND OTHER LIMITATIONS APPLY. REFER TO PRE-INSTALLATION
 GUIDE FOR DETAILS.

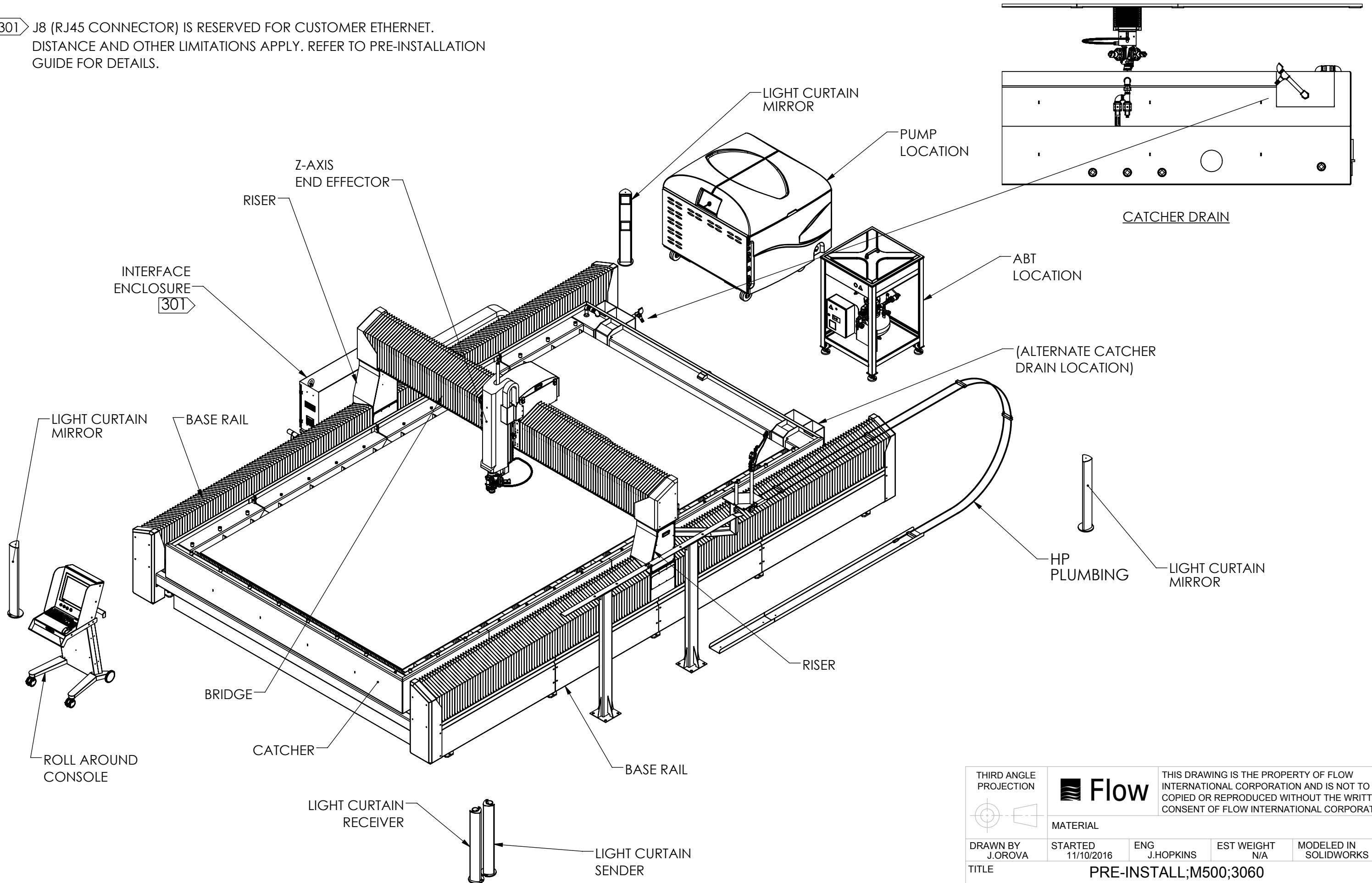

UNCONTROLLED COPY. USER IS RESPONSIBLE FOR VERIFYING THE CURRENT REVISION LEVEL.

THIRD ANGLE PROJECTION			THIS DRAWING IS THE PROPERTY OF FLOW INTERNATIONAL CORPORATION AND IS NOT TO BE COPIED OR REPRODUCED WITHOUT THE WRITTEN CONSENT OF FLOW INTERNATIONAL CORPORATION.		
	MATERIAL				
DRAWN BY J.OROVA	STARTED 11/10/2016	ENG J.HOPKINS	EST WEIGHT N/A	MODELED IN SOLIDWORKS	
TITLE			PRE-INSTALL;M500;3060		
REVISION 02	SCALE 1:40	BASE PART NUMBER	059874		3 OF 3