

AHB

TOOLING & MACHINERY

COMPLETE METALWORKING SOLUTIONS

(800) 991-4225

www.ahbinc.com

ISO Certified

customerservice@ahbinc.com

GORBEL[®]
A CLASS ABOVE

www.gorbel.com

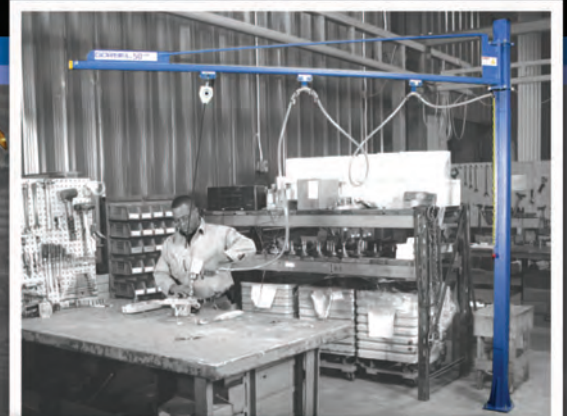

CRANES

JIB CRANES

Capacities from 50 pounds to 5 tons

Performance I-Beam Jibs
Enclosed Track Work Station Jibs
Articulating Jibs
Light Duty Tool Suspension Jibs
PIVOT PRO[®] Vacuum Sealed Jibs

Why Choose Gorbel® Products?

- 1 Industry's Best Warranty**
 We are proud to offer a ten year (20,000 hour) warranty on manually operated crane systems. With this warranty, our customers are guaranteed years of quality, dependable service.
- 2 Quick Ship Programs**
 Gorbel offers a 5-Day Quick Ship program which means that most cranes and most components can ship in five working days. Fast, reliable, on time shipments are just one of many ways Gorbel is working with our customers to make it easier to purchase our products. Optional two and three day shipments are also available at a premium.
- 3 Reliability**
 Since 1996 our on-time shipping percentage has been over 99%. We're proud that our customers can rely on us to ship their orders on time, keeping to their installation schedules. No other manufacturer in the industry can offer five day shipping and a 99% on-time rate.
- 4 Ease of Installation**
 We've been told time and time again that our products are much easier to install than others in the industry.
- 5 "If it's late, we pay the freight"**
 With this program if we don't have an order ready to ship on or before the scheduled ship date, we will pay the freight for the order. Contact your local Gorbel® dealer for details.
- 6 Multiple Shipping Points**
 With manufacturing facilities in Fishers, New York; Pell City, Alabama; and Tianjin, China, we are able to offer multiple shipping points, decreasing shipping costs to our customers.
- 7 Extensive Dealer Network**
 Our network of dealers extends across North America and many countries internationally, making it easier for a trained local material handling sales consultant to provide the best solution for your needs.
- 8 Customer Service Support**
 Our customer service teams are the best in the industry.

Selecting Your Jib Crane

	Crane Type	Best Use	Standard Capacities	Standard Spans	Motorized Option	Special Foundation Requirements	Beam Type	Page Number
Performance	Free Standing I-Beam Jibs	Heavy duty, high productivity applications	1/4 ton - 5 tons	8' - 20'	●	Some designs	Structural beam	4-5
	Wall Bracket Jibs	An economical heavy duty solution	1/2 ton - 5 tons	8' - 30'	●	None	Structural beam	6-7
	Wall Cantilever Jibs	An ideal jib for maximizing headroom	1/4 ton - 5 tons	8' - 20'	●	None	Structural beam	8-9
	Mast Type Jibs	Reduced thrust and pull	1/4 ton - 5 tons	10' - 20'	●	None	Structural beam	10-11
Enclosed Track	Work Station Jibs	Lower capacity, high productivity applications	Up to 2000 pounds	4' - 16'		Some designs	Enclosed track	14-16
	Aluminum Wall Bracket Jibs	Easiest movement with minimal bounce	Up to 2000 pounds	4' - 20'		None	Enclosed track	17
	Tool Support Jibs	Suspension of tools, management of cables	50 - 150 pounds	4' - 12'		None	Enclosed track	18-19
Articulating	Articulating Jibs	Reaching around corners or into machines	Up to 2000 pounds	8' - 16'		Some designs	Tubing	22-24
	PIVOT PRO®	Optimized to pair with vacuum tube lifters and air hoists	Up to 150 pounds	8' - 12'		None	Tubing	25-27

Motorized Rotation Jib Cranes



Motorized Jibs are available in the Free Standing, Wall Bracket, Wall Cantilever, and Mast Type Series. Retrofit Motorized kits for Free Standing Jibs are also available.

Why a Gorbel® Motorized Jib Crane?

Gorbel® Motorized Jibs are not mere adaptations. They are totally conceived as motorized products, with all the outstanding features of our standard jib cranes, plus these:

Control

- Variable Frequency Drives (VFD) are standard on all Motorized Jib Cranes. The drive can be configured for single or multiple speeds

Long Life

- Precision drive assembly with field adjustable torque limiter for added drive protection
- Worm gear reducer with oil bath lubrication for reliable operation and low maintenance. Worm gear reducer includes overload safety clutch
- Heavy-duty, totally enclosed, fan cooled, 3 phase Class B, 40°C ambient continuous, "C" faced motor, 30 minute rated, is standard

Precision

- Direct drive for all series jib cranes allows for accurate and consistent positioning of loads. This modular drive design makes maintenance easy and reduces long term costs
- Wall Cantilever and Mast Type masts are boxed for extra rigidity to withstand the forces of a Motorized Crane and provide more precise load control

Motorized Control Package Features

Variable Frequency Drive (VFD) is standard

- The Variable Frequency Drive can be used in one, two or three speed applications

VFD provides the ultimate in load control

- The VFD provides the ultimate in load control and positioning from the slowest possible creep speed up to the maximum speed

Easily adjustable speed control

- Through a simple keypad on the VFD, the acceleration rate, deceleration rate and rotation speed can be adjusted to fit your application. This allows you to customize the performance of the jib to your exact requirements

Designed for indoor and outdoor use

- When being used outdoors, the cranes are designed to operate in winds of 15 mph or less, based on a maximum load surface of 64 square feet. Consult the factory for applications exceeding these standards

Standard NEMA Rated Control Enclosure

- Gorbel's standard control enclosure meets the requirements for NEMA 3R, 12 and 4 environments. Optional enclosures are available for other environments

Low Maintenance Costs

- The VFD eliminates the need for magnetic reversing contactors, reduces the number of wearable components in the panel, and reduces long-term maintenance costs

Retrofit Existing Jibs with Motorized Rotation

The Retrofit Traction Drive kit will fit all Free Standing Jibs with box-style head assemblies no matter who made your jib crane. The modular drive assembly bolts to the back of the box-style head assembly. The friction drive powers large, heavy-walled rollers. The drive roller is easily adjusted to ensure a constant driving force. This is a great way to upgrade an existing Free Standing Jib Crane with motorized power making the Retrofit Kit a great, cost-effective way to solve workers' compensation or safety problems. Retrofit Traction Drive kits are available for indoor applications up to 5 ton with spans to 20 feet.



Retrofit Drive

Free Standing Jib Cranes

For heavy duty, high productivity applications

Free Standing Jib Cranes are Gorbel's most versatile crane. They are perfect to place underneath large bridge cranes, in open areas where they can serve several work stations, in outdoor applications such as loading docks, or in machining and assembly operations where they can be overlapped with other jibs to provide staged operation.

Gorbel's Advantage:

Ease of Operation

- Allows operators to position loads precisely, effortlessly and efficiently
- Precision tapered roller bearings in top pivot and trunnion assemblies provide smooth operation and long life
- Full supporting triangular base plate gussets are used (in lieu of struts) to minimize crane deflection, thus making it easier to accurately position loads

Ease of Installation

- Independent head assembly, installed separately from the boom for easier installation
- Recessed bearing assembly allows greatly reduced clearances needed for installation
- Bolted head/boom connection which permits separate installation and provides maximum lift for the hoist, since it can be installed very close to the underside of the lower ceiling obstruction for greater headroom
- Movable bolted trolley stops
- In-head totally enclosed, bottom entry collector assembly allows the option of easily adding power to the hoist for 360° rotation at the time of or after purchase



Safety

- Head retaining pin provides resistance to accidental upward dislodgement of the head

Full Rated Capacity

- Pre-engineered for use with powered hoists. A factor of 15% of the jib crane capacity is allowed for the hoist and trolley weight with an additional 25% of the capacity allowed for impact, thus giving full rated capacity use of the jib



Power rotation is an available option.

Designed for Performance

Gorbel's boxed style head provides benefits from installation through operation of the jib crane.

The design allows for installation of the head prior to the boom, which reduces the required installation clearances and allows maximum hoist lift.

The boxed style head also increases stability versus common sleeve-over-pipe designs. The result is less deflection and bouncing of the load, which creates a safer application with reduced risk of product damage.

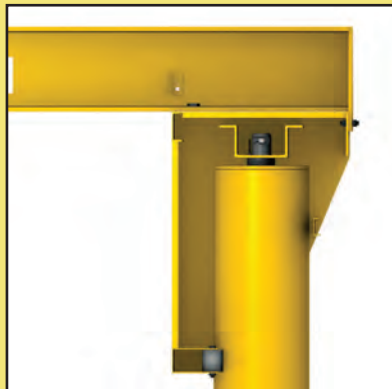

Free Standing Mounting Styles

FS300 - Baseplate Mounted



FS350 - Insert Mounted
(permanent mount)

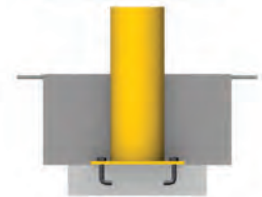

FS350S - Insert
Sleeve Mounted
(jib can be removed)

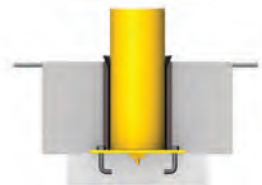

FS300 Baseplate Mounted

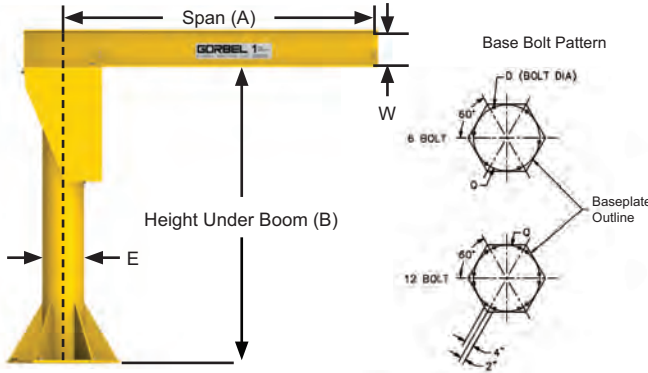

Mast Diameter (E)	8"	12"	14"	16"	18"	20"	24"	30"
Number of Anchor Bolts	6	6	6	12	12	12	12	12
Bolt Diameter (D)	1"	1" or 1.25"	1.25"	1.25"	1.25"	1.25"	1.25"	1.25"
Bolt Circle* (Q)	24"	24"	30"	36"	42"	48"	54"	60"

Note: For jib crane foundation requirements, overturning moment, axial load and anchor bolt pull out forces, consult your local Gorbel® dealer.
 *Dimensions from corners of the hexagonal baseplate are 6" longer than the corresponding bolt circle.

CAPACITY	HUB (B)	SPAN (A)							
		8'	10'	12'	14'	16'	18'	20'	30'
1/4 Ton	8'	FS300-8-6	FS300-8-6	FS300-8-6	FS300-12-W8	FS300-12-W8	FS300-12-10	FS300-12-10	FS300-12-10
	10'	FS300-8-6	FS300-8-6	FS300-8-6	FS300-12-W8	FS300-12-W8	FS300-12-10	FS300-12-10	FS300-12-10
	12'	FS300-8-6	FS300-8-6	FS300-12-6	FS300-12-W8	FS300-12-W8	FS300-12-10	FS300-12-10	FS300-12-10
	14'	FS300-8-6	FS300-8-6	FS300-12-6	FS300-12-W8	FS300-12-W8	FS300-12-10	FS300-14-10	FS300-14-10
	16'	FS300-8-6	FS300-8-6	FS300-12-6	FS300-12-W8	FS300-12-W8	FS300-12-10	FS300-14-10	FS300-14-10
	18'	FS300-8-6	FS300-12-6	FS300-12-6	FS300-12-W8	FS300-14-W8	FS300-14-10	FS300-14-10	FS300-14-10
1/2 Ton	8'	FS300-8-6	FS300-8-6	FS300-12-W8	FS300-12-W8	FS300-12-10	FS300-12-10	FS300-12-12	FS300-14-12
	10'	FS300-8-6	FS300-8-6	FS300-12-W8	FS300-12-W8	FS300-12-10	FS300-12-10	FS300-12-12	FS300-14-12
	12'	FS300-8-6	FS300-12-6	FS300-12-W8	FS300-12-12	FS300-12-12	FS300-14-W16	FS300-14-W16	FS300-14-W16
	14'	FS300-8-6	FS300-12-6	FS300-12-10	FS300-12-12	FS300-12-12	FS300-14-W16	FS300-14-W16	FS300-14-W16
	16'	FS300-8-6	FS300-12-6	FS300-12-10	FS300-12-12	FS300-14-12	FS300-14-W16	FS300-16-W16	FS300-16-W16
	18'	FS300-8-6	FS300-12-6	FS300-12-10	FS300-14-12	FS300-14-12	FS300-16-W16	FS300-16-W16	FS300-16-W16
1 Ton	8'	FS300-12-W8	FS300-12-W8	FS300-12-10	FS300-14-12	FS300-14-12	FS300-14-W16	FS300-14-W16	FS300-14-W16
	10'	FS300-12-W8	FS300-12-W8	FS300-12-10	FS300-14-12	FS300-14-12	FS300-14-W16	FS300-14-W16	FS300-14-W16
	12'	FS300-12-W8	FS300-12-W8	FS300-14-10	FS300-14-12	FS300-16-12	FS300-16-W16	FS300-16-W16	FS300-16-W16
	14'	FS300-12-W8	FS300-12-W8	FS300-14-10	FS300-14-12	FS300-16-12	FS300-18-W16	FS300-18-W16	FS300-18-W16
	16'	FS300-12-W8	FS300-12-W8	FS300-14-10	FS300-16-12	FS300-18-12	FS300-18-W16	FS300-18-W16	FS300-18-W16
	18'	FS300-12-W8	FS300-14-W8	FS300-16-10	FS300-16-12	FS300-18-12	FS300-18-W16	FS300-18-W16	FS300-18-W16
2 Ton	8'	FS300-14-10	FS300-14-12	FS300-16-12	FS300-16-W16	FS300-16-W18	FS300-18-W18	FS300-18-W18	FS300-18-W18
	10'	FS300-14-10	FS300-14-12	FS300-16-12	FS300-16-W16	FS300-16-W18	FS300-18-W18	FS300-18-W18	FS300-18-W18
	12'	FS300-14-10	FS300-14-12	FS300-16-12	FS300-16-W16	FS300-16-W18	FS300-18-W18	FS300-18-W18	FS300-18-W18
	14'	FS300-14-10	FS300-14-12	FS300-16-12	FS300-16-W16	FS300-18-W18	FS300-18-W18	FS300-18-W18	FS300-20-W18
	16'	FS300-14-10	FS300-14-12	FS300-16-12	FS300-18-W16	FS300-18-W18	FS300-18-W18	FS300-18-W18	FS300-24-W18
	18'	FS300-14-10	FS300-16-12	FS300-18-12	FS300-18-W16	FS300-20-W18	FS300-20-W18	FS300-20-W18	FS300-24-W18
3 Ton	8'	FS300-16-12	FS300-16-W16	FS300-18-W16	FS300-18-W18	FS300-20-W18	FS300-20-W21	FS300-24-W24	FS300-24-W24
	10'	FS300-16-12	FS300-16-W16	FS300-18-W16	FS300-18-W18	FS300-20-W18	FS300-20-W21	FS300-24-W24	FS300-24-W24
	12'	FS300-16-12	FS300-16-W16	FS300-18-W16	FS300-18-W18	FS300-20-W18	FS300-20-W21	FS300-24-W24	FS300-24-W24
	14'	FS300-16-12	FS300-16-W16	FS300-18-W16	FS300-18-W18	FS300-20-W18	FS300-20-W21	FS300-24-W24	FS300-24-W24
	16'	FS300-16-12	FS300-16-W16	FS300-18-W16	FS300-18-W18	FS300-20-W18	FS300-24-W21	FS300-24-W24	FS300-24-W24
	18'	FS300-16-12	FS300-16-W16	FS300-18-W16	FS300-20-W18	FS300-24-W18	FS300-24-W21	FS300-24-W24	FS300-24-W24
5 Ton	8'	FS300-18-W16	FS300-20-W18	FS300-24-W18	FS300-24-W21	FS300-24-W24	FS300-30-W24	FS300-30-W24	FS300-30-W24
	10'	FS300-18-W16	FS300-20-W18	FS300-24-W18	FS300-24-W21	FS300-24-W24	FS300-30-W24	FS300-30-W24	FS300-30-W24
	12'	FS300-18-W16	FS300-20-W18	FS300-24-W18	FS300-24-W21	FS300-24-W24	FS300-30-W24	FS300-30-W24	FS300-30-W24
	14'	FS300-18-W16	FS300-20-W18	FS300-24-W18	FS300-24-W21	FS300-24-W24	FS300-30-W24	FS300-30-W24	FS300-30-W24
	16'	FS300-18-W16	FS300-20-W18	FS300-24-W18	FS300-24-W21	FS300-24-W24	FS300-30-W24	FS300-30-W24	FS300-30-W24
	18'	FS300-18-W16	FS300-20-W18	FS300-24-W18	FS300-24-W21	FS300-24-W24	FS300-30-W24	FS300-30-W24	FS300-30-W24

30' Span Jibs Available - Consult Gorbel® Customer Service for additional information.

Model Number Explanation

Example: 1/4 Ton FS300-8-6; 1/4 Ton = 500 pound capacity, FS300 = base plate mount style, 8 = mast diameter in inches (E), 6 = beam size in inches (W). Use "E" dimension above to determine base plate and anchor bolt dimensions.

Other Models, Sizes and Capacities Readily Available

FS350 (insert mounted), FS350S (sleeve insert mounted), and other spans, heights, and capacities are available by contacting your local Gorbel® dealer.

Note: Dimensions are subject to change without notice.

Wall Bracket Jib Cranes

An economical heavy duty solution

The Wall Bracket (WB100) Jib is the most economical means of providing hoist coverage for individual use in bays, along walls or columns of plants, or as a supplement to an overhead crane or monorail system.

Two key requirements must be met before applying the Wall Bracket Series:

1. A structurally adequate wall or column to support the jib must exist
2. Sufficient clearance above the boom throughout its arc to accommodate the tie rod suspension must exist

Gorbel's Advantage:

Ease of Movement

- Low dead weight of the boom combined with bronze bushings and oil-impregnated bronze thrust washers provide for easy rotation and superior load positioning

Safety

- Formed bracket fittings provide for greater reliability. No welds in tension, all bolts are in double shear for increased strength

Full Rated Capacity

- Pre-engineered for use with powered hoists. A factor of 15% of the jib crane capacity is allowed for the hoist and trolley weight with an additional 25% of the capacity allowed for impact, thus giving full rated capacity use of the jib



Ease of Installation

- Single tie rod, right hand threaded at both ends for easy leveling
- All connections bolted, including movable bolted trolley stops
- Grease fittings are provided for easy field lubrication



200° Power rotation is an available option.

WB100 - Wall Bracket Jib

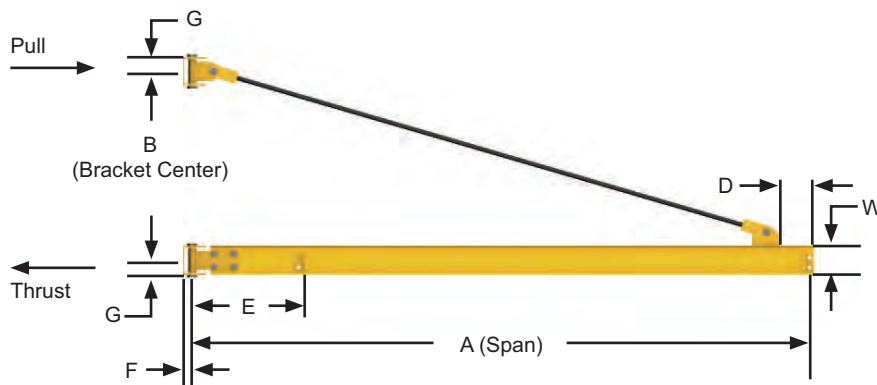

The Thrust & Pull diagram above details the thrust and pull forces that the jib applies to the supporting structure when a load is lifted. It is essential that a structurally adequate wall or column exists. Refer to the Thrust & Pull chart opposite this page for exact forces.

Fitting kits are available for fabrication of cranes locally.

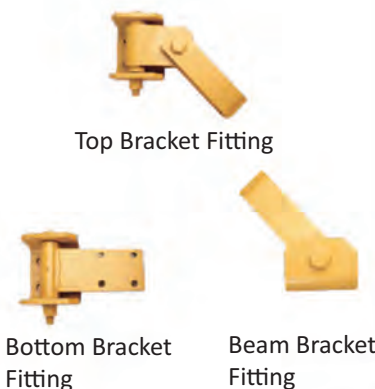

WB100 Wall Bracket

CAPACITY	SPAN (A)	MODEL NUMBER	B	D	E	F	G	W	TIE ROD DIAMETER	THRUST & PULL
1/2 Ton	8'	WB100-G1-8-6	2' 9"	1' 3"	13-1/2"	3-1/2"	3-1/2"	6"	1"	3709#
	10'	WB100-G1-10-6	3' 0"	1' 6"	13-1/2"	3-1/2"	3-1/2"	6"	1"	4408#
	12'	WB100-G1-12-6	3' 9"	1' 9"	13-1/2"	3-1/2"	3-1/2"	6"	1"	4347#
	14'	WB100-G1-14-6	4' 6"	2' 0"	13-1/2"	3-1/2"	3-1/2"	6"	1"	4317#
	16'	WB100-G1-16-6	5' 6"	2' 0"	13-1/2"	3-1/2"	3-1/2"	6"	1"	4109#
	18'	WB100-G1-18-W8	6' 0"	2' 0"	13-1/2"	3-1/2"	3-1/2"	8"	1"	4453#
	20'	WB100-G1-20-W8	6' 6"	2' 3"	13-1/2"	3-1/2"	3-1/2"	8"	1"	4646#
	24'	WB100-G1-24-W8c6	7' 6"	2' 6"	13-1/2"	3-1/2"	3-1/2"	8"	1"	5426#
	30'	WB100-G1-30-12c8	10' 0"	3' 6"	13-1/2"	3-1/2"	3-1/2"	12"	1"	6009#
1 Ton	8'	WB100-G1-8-6	2' 9"	1' 3"	13-1/2"	3-1/2"	3-1/2"	6"	1"	7273#
	10'	WB100-G1-10-6	3' 0"	1' 6"	13-1/2"	3-1/2"	3-1/2"	6"	1"	8608#
	12'	WB100-G1-12-6	3' 9"	1' 9"	13-1/2"	3-1/2"	3-1/2"	6"	1"	8453#
	14'	WB100-G1-14-W8	4' 6"	2' 0"	13-1/2"	3-1/2"	3-1/2"	8"	1"	8481#
	16'	WB100-G1-16-W8	5' 6"	2' 3"	13-1/2"	3-1/2"	3-1/2"	8"	1"	8055#
	18'	WB100-G1-18-W8	6' 0"	2' 6"	13-1/2"	3-1/2"	3-1/2"	8"	1"	8419#
	20'	WB100-G1-20-10	6' 6"	2' 6"	13-1/2"	3-1/2"	3-1/2"	10"	1"	8966#
	24'	WB100-G1-24-10c6	7' 6"	2' 9"	13-1/2"	3-1/2"	3-1/2"	10"	1"	9877#
	30'	WB100-G1-30-12c8	10' 0"	3' 6"	13-1/2"	3-1/2"	3-1/2"	12"	1"	10069#
2 Ton	8'	WB100-G2-8-W8	2' 9"	1' 3"	13-1/2"	4"	4-1/8"	8"	1-1/2"	14464#
	10'	WB100-G2-10-W8	3' 0"	1' 6"	13-1/2"	4"	4-1/8"	8"	1-1/2"	17100#
	12'	WB100-G2-12-W8	3' 9"	1' 9"	13-1/2"	4"	4-1/8"	8"	1-1/2"	16772#
	14'	WB100-G2-14-W8	4' 6"	2' 0"	13-1/2"	4"	4-1/8"	8"	1-1/2"	16570#
	16'	WB100-G2-16-10	5' 6"	2' 3"	13-1/2"	4"	4-1/8"	10"	1-1/2"	15864#
	18'	WB100-G2-18-12	6' 0"	2' 3"	13-1/2"	4"	4-1/8"	12"	1-1/2"	16725#
	20'	WB100-G2-20-12	6' 6"	2' 6"	13-1/2"	4"	4-1/8"	12"	1-1/2"	17348#
	24'	WB100-G2-24-12c8	7' 6"	3' 0"	13-1/2"	4"	4-1/8"	12"	1-1/2"	18836#
	30'	WB100-G2-30-12c8	10' 0"	3' 0"	13-1/2"	4"	4-1/8"	12"	1-1/2"	18189#
3 Ton	8'	WB100-G3-8-W8	2' 9"	1' 3"	14"	4"	4-5/8"	8"	1-1/2"	21591#
	10'	WB100-G3-10-W8	3' 3"	1' 6"	14"	4"	4-5/8"	8"	1-1/2"	23539#
	12'	WB100-G3-12-10	4' 0"	1' 9"	14"	4"	4-5/8"	10"	1-1/2"	23557#
	14'	WB100-G3-14-10	4' 9"	2' 0"	14"	4"	4-5/8"	10"	1-1/2"	23514#
	16'	WB100-G3-16-12	5' 6"	2' 3"	14"	4"	4-5/8"	12"	1-1/2"	23649#
	18'	WB100-G3-18-12c8	6' 3"	2' 3"	14"	4"	4-5/8"	12"	1-1/2"	23970#
	20'	WB100-G3-20-12c8	7' 0"	2' 6"	14"	4"	4-5/8"	12"	1-1/2"	24037#
	24'	WB100-G3-24-12c8	8' 6"	3' 0"	14"	4"	4-5/8"	12"	1-1/2"	24197#
	30'	WB100-G3-30-12c10	11' 0"	3' 0"	14"	4"	4-5/8"	12"	1-1/2"	24072#
5 Ton	8'	WB100-G5-8-12	3' 0"	1' 6"	15-1/4"	6"	7"	12"	2"	33006#
	10'	WB100-G5-10-12	3' 3"	1' 6"	15-1/4"	6"	7"	12"	2"	39258#
	12'	WB100-G5-12-12	4' 0"	1' 9"	15-1/4"	6"	7"	12"	2"	39072#
	14'	WB100-G5-14-12c8	4' 9"	2' 0"	15-1/4"	6"	7"	12"	2"	39209#
	16'	WB100-G5-16-W16	5' 6"	2' 6"	15-1/4"	6"	7"	16"	2"	39229#
	18'	WB100-G5-18-W16	6' 3"	3' 0"	15-1/4"	6"	7"	16"	2"	39246#
	20'	WB100-G5-20-W16	7' 0"	3' 6"	15-1/4"	6"	7"	16"	2"	39286#
	24'	WB100-G5-24-W16c12	8' 9"	3' 6"	15-1/4"	6"	7"	16"	2"	39926#
	30'	WB100-G5-30-W16c12	11' 0"	3' 6"	15-1/4"	6"	7"	16"	2"	39376#

Model Number Explanation

Example: 3 Ton WB100-G3-20-12c8; 3 Ton = 6,000 pound capacity, WB100 = wall bracket style, 20 = span (A), 12 = beam size in inches (W), c8 = 8" cap channel welded to top of boom.

Other Sizes & Capacities Readily Available

Other spans and capacities are available by contacting your local Gorbel® dealer.

Note: Dimensions are subject to change without notice.

Wall Cantilever Jib Cranes

An ideal jib for maximizing headroom

The Wall Cantilever (WC200) provides hoist coverage and 200° rotation for individual use in bays, along walls or columns of plants, or as a supplement to an overhead crane or monorail system. The jib has the advantage of providing maximum lift for the hoist, since it can be installed very close to the underside of the lowest ceiling obstruction.

Two key requirements must be met before applying the Wall Cantilever Series:

1. A structurally adequate wall or column to support the jib must exist
2. Sufficient clearance above the boom throughout its arc must exist

Gorbel's Advantage:

Ease of Movement

- The fittings contain bronze bushings and oil-impregnated bronze thrust washers which provide for easy rotation and superior load positioning

Safety

- Fabricated steel fittings provide excellent torsional rigidity

Full Rated Capacity

- Pre-engineered for use with powered hoists. A factor of 15% of the jib crane capacity is allowed for the hoist and trolley weight with an additional 25% of the capacity allowed for impact, thus giving full rated capacity use of the jib

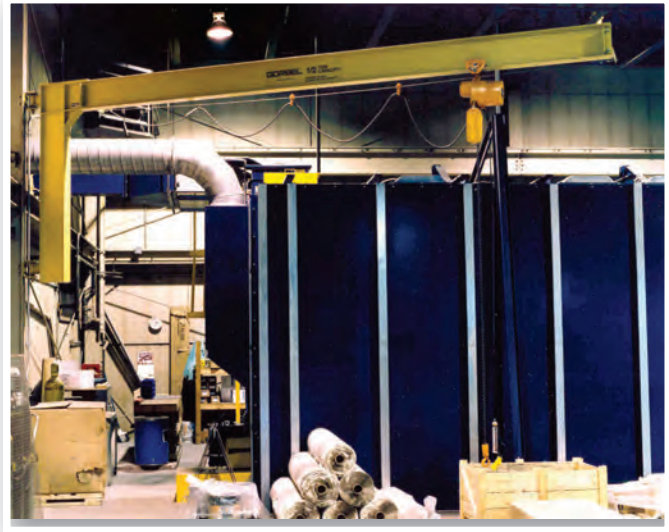

Ease of Installation

- When the bracket center dimension is 6' 0" or less, the mast/boom connection is welded. This provides the most economical means of installation
- When the bracket center is greater than 6' 0", a bolted mast/boom connection is used, which enables the larger cranes to be shipped disassembled for ease of handling during shipping and installation
- Grease fittings are provided for easy field lubrication



200° Power rotation is an available option.

WC200 Wall Cantilever Jib

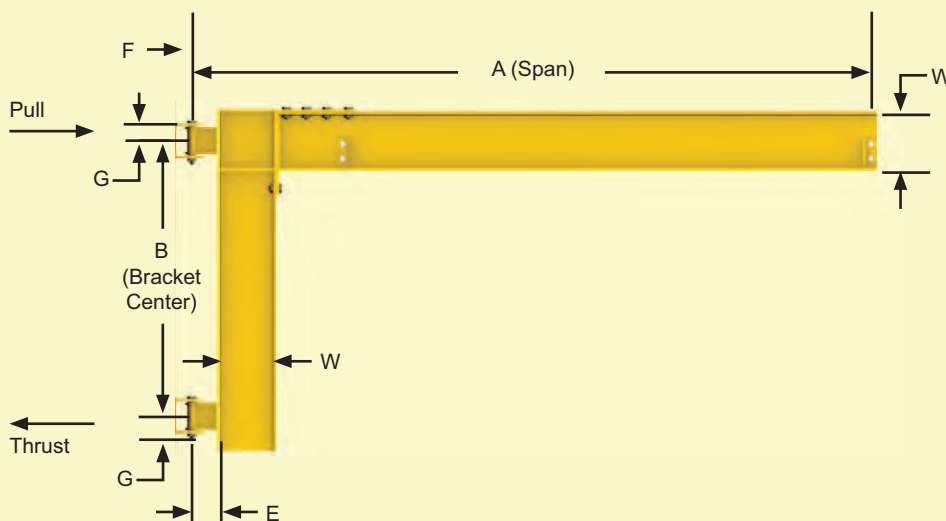

The Thrust & Pull diagram above details the thrust and pull forces that the jib applies to the supporting structure when a load is lifted. It is essential that a structurally adequate wall or column exists. Refer to the Thrust & Pull chart opposite this page for exact forces.

Top and Bottom Bracket Fittings



Wall Cantilever fitting kits are available for fabrication of cranes locally.

WC200 Wall Cantilever

CAPACITY	SPAN (A)	MODEL NUMBER	B	E	F	G	W	THRUST & PULL
1/4 Ton	8'	WC200-B1-8-6	3' 0"	5"	3-1/2"	6"	6"	1767#
	10'	WC200-B1-10-6	3' 0"	5"	3-1/2"	6"	6"	2308#
	12'	WC200-B1-12-6	3' 0"	5"	3-1/2"	6"	6"	2867#
	14'	WC200-B1-14-W8	3' 0"	5"	3-1/2"	6"	8"	3624#
	16'	WC200-B1-16-W8	3' 0"	5"	3-1/2"	6"	8"	4268#
	18'	WC200-B1-18-W8	4' 0"	5"	3-1/2"	6"	8"	3704#
	20'	WC200-B1-20-10	4' 0"	5"	3-1/2"	6"	10"	4595#
1/2 Ton	8'	WC200-B1-8-W8	3' 0"	5"	3-1/2"	6"	8"	3459#
	10'	WC200-B1-10-W8	3' 0"	5"	3-1/2"	6"	8"	4500#
	12'	WC200-B1-12-W8	3' 0"	5"	3-1/2"	6"	8"	5565#
	14'	WC200-B1-14-W8	4' 0"	5"	3-1/2"	6"	8"	4991#
	16'	WC200-B1-16-10	4' 0"	5"	3-1/2"	6"	10"	6063#
	18'	WC200-B1-18-10	4' 0"	5"	3-1/2"	6"	10"	6979#
	20'	WC200-B1-20-12	6' 0"	5"	3-1/2"	6"	12"	5493#
1 Ton	8'	WC200-B1-8-W8	4' 0"	5"	3-1/2"	6"	8"	5044#
	10'	WC200-B1-10-10	5' 0"	5"	3-1/2"	6"	10"	5294#
	12'	WC200-B1-12-10	5' 0"	5"	3-1/2"	6"	10"	6526#
	14'	WC200-B1-14-10	5' 0"	5"	3-1/2"	6"	10"	7778#
	16'	WC200-B1-16-12	6' 0"	5"	3-1/2"	6"	12"	7678#
	18'	WC200-B1-18-W16	6' 0"	5"	3-1/2"	6"	16"	9148#
	20'	WC200-B1-20-W16	6' 0"	5"	3-1/2"	6"	16"	10367#
2 Ton	8'	WC200-B2-8-12	4' 0"	5"	4"	6"	12"	10054#
	10'	WC200-B2-10-12	4' 0"	5"	4"	6"	12"	12998#
	12'	WC200-B2-12-W16	4' 6"	5"	4"	6"	16"	14409#
	14'	WC200-B2-14-W16	5' 0"	5"	4"	6"	16"	15442#
	16'	WC200-B2-16-W18	6' 0"	5"	4"	6"	18"	15067#
	18'	WC200-B2-18-W18	6' 6"	5"	4"	6"	18"	15892#
	20'	WC200-B2-20-W21	7' 6"	5"	4"	6"	21"	15840#
3 Ton	8'	WC200-B3-8-W16	4' 0"	5"	4"	6"	16"	15060#
	10'	WC200-B3-10-W16	4' 6"	5"	4"	6"	16"	17300#
	12'	WC200-B3-12-W16	5' 6"	5"	4"	6"	16"	17390#
	14'	WC200-B3-14-W18	6' 0"	5"	4"	6"	18"	19017#
	16'	WC200-B3-16-W18	7' 6"	5"	4"	6"	18"	17653#
	18'	WC200-B3-18-W21	8' 6"	5"	4"	6"	21"	17982#
	20'	WC200-B3-20-W21	9' 6"	5"	4"	6"	21"	18105#
5 Ton	8'	WC200-B5-8-W18	6' 6"	7"	6"	9"	18"	15323#
	10'	WC200-B5-10-W18	6' 6"	7"	6"	9"	18"	19770#
	12'	WC200-B5-12-W21	6' 6"	7"	6"	9"	21"	24379#
	14'	WC200-B5-14-W21	7' 6"	7"	6"	9"	21"	25077#
	16'	WC200-B5-16-W24	9' 6"	7"	6"	9"	21"	23240#
	18'	WC200-B5-18-W24	9' 6"	7"	6"	9"	24"	26485#
	20'	WC200-B5-20-W24	9' 6"	7"	6"	9"	24"	29769#

Model Number Explanation

Example: 1 Ton WC200-B1-12-10; 1 Ton = 2,000 pound capacity, WC200 = Wall Cantilever style, 12 = span (A), 10 = boom size in inches (W).

Other Sizes & Capacities Readily Available

Other spans and capacities are available by contacting your local Gorbel® dealer.

Note: Dimensions are subject to change without notice.

Mast Type Jib Cranes

Reduced thrust and pull forces, no foundation required



The MT Series Crane is floor supported, top stabilized, and is capable of 360° rotation via a top and bottom bearing assembly.

Three key requirements must be met before deciding on a Mast Type Jib Crane:

1. An adequate structural support to stabilize the crane at the top of the mast must exist. If the jib is installed underneath an overhead crane runway or building truss, then the deflection of the supporting member may not exceed 1/2 inch
2. Clearance overhead for the pivot assembly must exist
3. Clearance overhead for the boom to rotate must exist

Available in Two Styles

1. MT400 FULL CANTILEVER - provides for maximum amount of lift where full use of available headroom is desired
2. MT450 DROP CANTILEVER - jib boom can be placed at a specific height to clear overhead obstructions

Gorbel's Advantage:

Economical

- Simple, efficient design that usually requires no special foundation makes the Mast Type Cranes the most cost effective of the 360° rotation jib styles

Exerts Less Force On Building Structure

- Exerts the least amount of force of any Gorbel® jib on its supporting structure

Safety

- Utilizes a self-aligning radial bushing at the top which cannot be displaced, and an identical self-aligning radial bushing at the bottom which, when used in combination with an oil-impregnated bronze thrust washer, provides ease of movement

Full Rated Capacity

- Pre-engineered for use with powered hoists. A factor of 15% of the jib crane capacity is allowed for the hoist and trolley weight with an additional 25% of the capacity allowed for impact, thus giving full rated capacity use of the jib

Productive

- Allows full utilization of the working area with 360° rotation

Maximum Trolley Travel

- Mast/beam connections eliminate the need for tie rods or knee braces found on competitive designs, thus permitting maximum trolley travel



Power rotation is an available option.

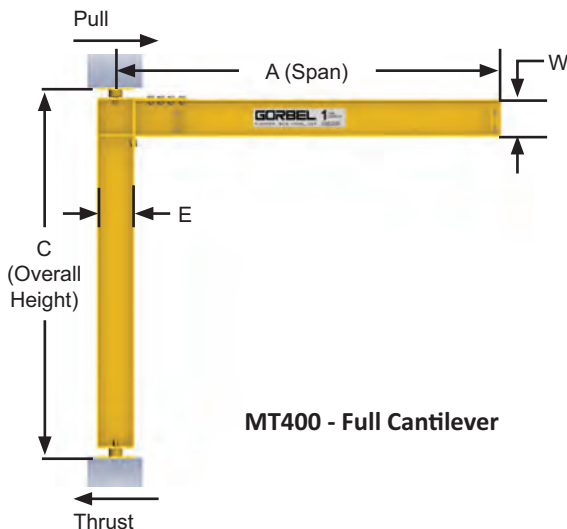

MT400 - Full Cantilever



MT450 - Drop Cantilever

The diagram above details the thrust and pull forces that the jib crane applies to the supporting structure when a load is lifted. It is essential that a structurally adequate wall or column exists to support the jib crane. Contact your local Gorbel® dealer for specific thrust and pull forces.

MT400 Mast Type Cranes

CAPACITY	OAH (C)	SPAN (A)						
		8'	10'	12'	14'	16'	18'	20'
1/4 Ton	10'	MT400-8-6-15	MT400-8-6-15	MT400-8-8-15	MT400-8-8-15	MT400-8-8-15	MT400-10-10-15	MT400-10-10-15
	12'	MT400-8-6-15	MT400-8-6-15	MT400-8-8-15	MT400-8-8-15	MT400-8-8-15	MT400-10-10-15	MT400-10-10-15
	14'	MT400-8-6-15	MT400-8-6-15	MT400-8-8-15	MT400-8-8-15	MT400-10-8-15	MT400-10-10-15	MT400-10-10-15
	16'	MT400-8-6-15	MT400-8-6-15	MT400-8-8-15	MT400-8-8-15	MT400-10-8-15	MT400-10-10-15	MT400-10-10-15
	18'	MT400-8-6-15	MT400-8-6-15	MT400-8-8-15	MT400-8-8-15	MT400-10-8-15	MT400-10-10-15	MT400-10-10-15
1/2 Ton	10'	MT400-8-6-15	MT400-10-8-15	MT400-10-8-15	MT400-14-10-15	MT400-14-10-15	MT400-14-12-15	MT400-14-12-15
	12'	MT400-8-6-15	MT400-10-8-15	MT400-10-8-15	MT400-14-10-15	MT400-14-10-15	MT400-14-12-15	MT400-14-12-15
	14'	MT400-8-6-15	MT400-10-8-15	MT400-10-8-15	MT400-14-10-15	MT400-14-10-15	MT400-14-12-15	MT400-14-12-15
	16'	MT400-8-6-15	MT400-10-8-15	MT400-10-8-15	MT400-14-10-15	MT400-14-10-15	MT400-14-12-15	MT400-14-12-15
	18'	MT400-8-6-15	MT400-10-8-15	MT400-10-8-15	MT400-14-10-15	MT400-14-10-15	MT400-14-12-15	MT400-14-12-15
1 Ton	10'	MT400-10-8-15	MT400-14-10-15	MT400-14-10-15	MT400-14-12-15	MT400-14-12-15	MT400-16-16-20	MT400-16-16-20
	12'	MT400-10-8-15	MT400-14-10-15	MT400-14-10-15	MT400-14-12-15	MT400-14-12-15	MT400-16-16-15	MT400-16-16-20
	14'	MT400-10-8-15	MT400-14-10-15	MT400-14-10-15	MT400-14-12-15	MT400-14-12-15	MT400-16-16-15	MT400-16-16-15
	16'	MT400-10-8-15	MT400-14-10-15	MT400-14-10-15	MT400-14-12-15	MT400-16-12-15	MT400-16-16-15	MT400-18-16-15
	18'	MT400-14-8-15	MT400-14-10-15	MT400-14-10-15	MT400-16-12-15	MT400-16-12-15	MT400-18-16-15	MT400-18-16-15
2 Ton	10'	MT400-14-10-15	MT400-14-12-20	MT400-16-16-20	MT400-16-16-20	MT400-18-18-20	MT400-18-18-25	MT400-21-21-25
	12'	MT400-14-10-15	MT400-14-12-20	MT400-16-16-20	MT400-16-16-20	MT400-18-18-20	MT400-18-18-20	MT400-21-21-20
	14'	MT400-14-10-15	MT400-16-12-15	MT400-16-16-20	MT400-18-16-20	MT400-18-18-20	MT400-18-18-20	MT400-21-21-20
	16'	MT400-14-10-15	MT400-16-12-15	MT400-18-16-15	MT400-18-16-20	MT400-18-18-20	MT400-18-18-20	MT400-21-21-20
	18'	MT400-16-10-15	MT400-16-12-15	MT400-18-16-15	MT400-18-16-15	MT400-18-18-20	MT400-21-18-20	MT400-21-21-20
3 Ton	10'	MT400-16-12-20	MT400-16-16-20	MT400-18-16-20	MT400-18-18-25	MT400-21-21-25	MT400-21-21-25	MT400-21-24-25
	12'	MT400-16-12-20	MT400-16-16-20	MT400-18-16-20	MT400-18-18-25	MT400-21-21-25	MT400-21-21-25	MT400-21-24-25
	14'	MT400-16-12-20	MT400-18-16-20	MT400-18-16-20	MT400-18-18-20	MT400-21-21-25	MT400-21-21-25	MT400-21-24-25
	16'	MT400-18-12-15	MT400-18-16-20	MT400-18-16-20	MT400-18-18-20	MT400-21-21-20	MT400-21-21-25	MT400-24-24-25
	18'	MT400-18-12-15	MT400-18-16-15	MT400-18-16-20	MT400-21-18-20	MT400-21-21-20	MT400-24-21-20	MT400-24-24-25
5 Ton	10'	MT400-18-18-25	MT400-18-18-25	MT400-21-21-25	MT400-21-21-25	MT400-24-24-25	MT400-24-24-25	MT400-24-24-25
	12'	MT400-18-18-25	MT400-18-18-25	MT400-21-21-25	MT400-21-21-25	MT400-24-24-25	MT400-24-24-25	MT400-24-24-25
	14'	MT400-18-18-20	MT400-18-18-25	MT400-21-21-25	MT400-24-21-25	MT400-24-24-25	MT400-24-24-25	MT400-27-24-25
	16'	MT400-18-18-20	MT400-21-18-20	MT400-21-21-25	MT400-24-21-25	MT400-24-24-25	MT400-27-24-25	MT400-27-24-25
	18'	MT400-18-18-20	MT400-21-18-20	MT400-24-21-20	MT400-24-21-25	MT400-27-24-25	MT400-27-24-25	MT400-27-24-25
20'	MT400-21-18-20	MT400-21-18-20	MT400-24-21-20	MT400-24-21-25	MT400-27-24-25	MT400-27-24-25	MT400-27-24-25	

Model Number Explanation

Example: 1/2 Ton MT400-8-6-15; 1/2 Ton = 1,000 pound capacity, MT400 = full cantilever style, 8 = mast wide flange depth in inches (E), 6 = beam size in inches (W), 15 = mast pivot pin diameter (1-1/2").

Other Models, Sizes and Capacities Readily Available

MT450 (drop cantilever), and other spans, heights, and capacities are available by contacting your local Gorbel® dealer.

Note: Dimensions are subject to change without notice.

Work Station Jib Cranes

Lighter capacity, easy rolling enclosed track jibs

Gorbel® Work Station Jib Cranes provide excellent coverage in circular areas not efficiently served by a main crane. They're ideal for supporting tool balancers, air balancers, hoists, vacuum lifters and welding wire feeders. And they can handle up to 200° rotation when column or wall mounted, and up to 360° rotation when floor mounted.



Gorbel's Advantage:

Easy Movement

Gorbel® Work Station Jib Cranes are easier to move and position than traditional I-beam jibs. The cold-formed, high-strength enclosed track design keeps rolling surfaces clean, contributing to easier movement and longer life. The track's low weight-per-foot reduces the dead weight of the boom. And all Gorbel® enclosed track profiles feature 2° taper in the lower running flange which helps center the trolley in the track, increasing wheel life and allowing smooth rolling of the trolleys.

Unsurpassed Ease of Rotation

The steel enclosed track work station jibs (WSJ360, WSJ200, TSJ50 and TSJ150) weigh less and rotate easier than traditional I-beam cranes. The aluminum wall mounted jibs (AL100) feature extruded aluminum enclosed track that is lighter in weight for even easier movement of the boom.

Precise Load Positioning

A hoist trolley with low rolling resistance and lubricated-for-life sealed bearings combined with easy rotation of the boom help to precisely position and spot loads.

DURACOMP 4® Wheels

Gorbel® trolley wheels are made of DURACOMP 4® - a food grade material that outperforms steel wheels in endurance and destructive testing. Wheels are tapered to match the track flange's 2° taper, which enhances wheel life and keeps the trolleys running smoothly.

Pre-engineered for Powered Hoists

Hoist trolleys are included in the base price of all Gorbel® Work Station Jib Cranes. A factor of 15% of the jib capacity is allowed for the weight of the hoist, trolley and below-the-hook device. A factor of 25% of the jib capacity is allowed for impact (covers hoist speeds up to 50 fpm).

Work Station Jib Reduces Worker Injuries

This customer was changing the chuck on a CNC machine by hand, requiring two men and causing physical injuries. The company wanted to reduce back injuries while maximizing safety and ergonomics.

The customer first looked at a Gorbel® WSJ360 but there was not enough room between the machines for the footings. Monorails were unable to cover the entire area.

The Gorbel® WSJ200 Work Station Jib Crane was the most cost effective and least disruptive solution. It allowed the maintenance to be performed by only one person and reduced the risk of back injury. With no footing, it allowed the customer to maximize their work space.



Enclosed Track Jibs

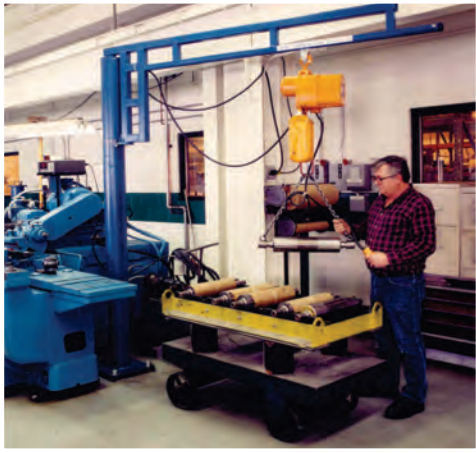

WSJ360 Free Standing Work Station Jib Cranes

360° Rotation

In most cases, Gorbel® WSJ360 Free Standing Series Jib Cranes can be bolted directly to your existing floor without adding special foundations (see the specific product information on the pages that follow for more details). Installation and adjustment are easy with our eccentric cam followers. Free Standing Work Station Jibs are available in capacities to 1000 lb. and spans up to 16'. See pages 14-15 for details.



WSJ200 Wall Cantilever Work Station Jib Cranes

200° Rotation

The wall or column mounted WSJ200 crane uses tapered roller bearings at the pivot points for unsurpassed ease of rotation. The cantilevered design of the WSJ200 allows for maximum headroom. Wall Cantilever Work Station Jib Cranes are available in capacities to 1000 lb. and spans up to 16'. See page 16 for details.



AL100 Wall Bracket Work Station Jib Cranes

200° Rotation

The AL100 Wall Bracket Work Station Jib Crane utilizes Gorbel's patented light weight, high-strength extruded aluminum enclosed track for its boom. This revolutionary new aluminum track reduces the rotational dead weight of the boom by 56% to 68%, allowing the AL100 to rotate up to 40% easier than a comparable I-beam jib. Sufficient clearance throughout the arc of the boom must exist to accommodate the tie rod suspension. AL100 jibs are available in capacities to 2000 lb. with spans up to 20'. See page 17 for details.



TSJ50 & TSJ150 Tool Solution Jib Cranes

Up to 200° Rotation

Gorbel's Tool Solutions jib cranes were designed to be a durable, lightweight option for applications with suspended tooling or light duty lifting. The small footprint of these cranes makes installation possible in small areas, such as between machines. Tool Solution Jibs are available in 50 lb. and 150 lb. capacities with spans up to 12'. See pages 18-19 for details.

WSJ360 Free Standing Work Station Jibs: 360° Rotation

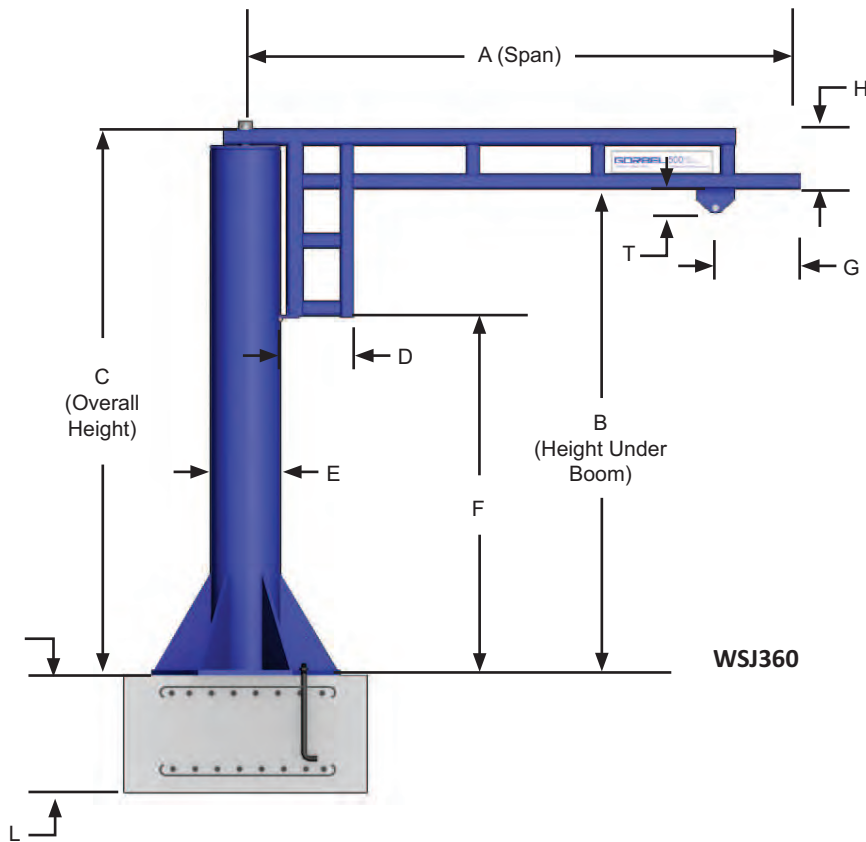

Base Bolt Patterns

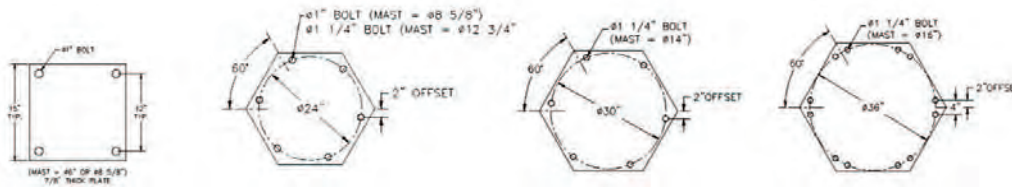

WSJ360 is available in stainless steel for models with 250 or 500 lb. capacities.

Jib crane foundation requirements are based on a soil pressure of 2500# per square foot. Concrete recommended for jib crane foundation is 3000# per square inch of compressive force.

Standard hoist trolley and end stops included in the base price. Festooning, anchor bolts and installation templates are optional. Hoist by others. Dimensions and design details subject to change without notice. Existing floor should have no cracks or seams within a 48" square area around center of mast.



WSJ360 Portable Base: To allow a WSJ360 to be lifted with a lift truck and transported to multiple locations, a portable base is required.

WSJ360 Free Standing Work Station Jibs: 360° Rotation

CAPACITY	HUB (B)	SPAN (A)	MODEL NUMBER	TRACK SERIES	WEIGHT	C	D	E	F	G	H	L	T	BOLT QTY.	ANCHOR BOLT LOAD
						in	in	in	in	in	in	in	in		
150#	8'	8'	WSJ360-150-8-8	250	390#	108-1/4	9-3/4	6-5/8	73-7/8	5	9	6	1-1/2	4	820#
		10'	WSJ360-150-8-10	250	411#	108-1/4	9-3/4	6-5/8	73-7/8	5	9	6	1-1/2	4	1100#
		12'	WSJ360-150-8-12	250	443#	111-1/4	12-3/4	6-5/8	64-7/8	5	12	6	1-1/2	4	1390#
		14'	WSJ360-150-8-14	500	511#	113-3/4	16-1/4	6-5/8	55-7/8	7-1/8	15	6	2-7/8	4	1830#
		16'	WSJ360-150-8-16	500	589#	113-3/4	16-1/4	6-5/8	55-7/8	7-1/8	15	6	2-7/8	4	2190#
	10'	8'	WSJ360-150-10-8	250	427#	132-1/4	9-3/4	6-5/8	97-7/8	5	9	6	1-1/2	4	810#
		10'	WSJ360-150-10-10	250	448#	132-1/4	9-3/4	6-5/8	97-7/8	5	9	6	1-1/2	4	1090#
		12'	WSJ360-150-10-12	250	487#	135-1/4	12-3/4	6-5/8	88-7/8	5	12	6	1-1/2	4	1380#
		14'	WSJ360-150-10-14	500	549#	137-3/4	16-1/4	6-5/8	79-7/8	7-1/8	15	6	2-7/8	4	1820#
		16'	WSJ360-150-10-16	500	634#	137-3/4	16-1/4	6-5/8	79-7/8	7-1/8	15	6	2-7/8	4	2180#
	12'	8'	WSJ360-150-12-8	250	465#	156-1/4	9-3/4	6-5/8	121-7/8	5	9	6	1-1/2	4	800#
		10'	WSJ360-150-12-10	250	486#	156-1/4	9-3/4	6-5/8	121-7/8	5	9	6	1-1/2	4	1080#
		12'	WSJ360-150-12-12	250	519#	159-1/4	12-3/4	6-5/8	112-7/8	5	12	6	1-1/2	4	1370#
		14'	WSJ360-150-12-14	500	630#	161-3/4	16-1/4	8-5/8	103-7/8	7-1/8	15	6	2-7/8	4	1800#
		16'	WSJ360-150-12-16	500	679#	161-3/4	16-1/4	8-5/8	103-7/8	7-1/8	15	6	2-7/8	4	2170#
250#	8'	8'	WSJ360-250-8-8	250	461#	108-1/4	9-3/4	6-5/8	73-7/8	5	9	6	1-1/2	4	1310#
		10'	WSJ360-250-8-10	250	499#	111-1/4	12-3/4	6-5/8	64-7/8	5	12	6	1-1/2	4	1730#
		12'	WSJ360-250-8-12	500	562#	114-1/4	12-3/4	8-5/8	55-7/8	7-1/8	15	36	2-7/8	6	910#
		14'	WSJ360-250-8-14	500	613#	113-3/4	16-1/4	8-5/8	55-7/8	7-1/8	15	36	2-7/8	6	1140#
		16'	WSJ360-250-8-16	500	661#	113-3/4	16-1/4	8-5/8	55-7/8	7-1/8	15	36	2-7/8	6	1370#
	10'	8'	WSJ360-250-10-8	250	535#	132-1/4	9-3/4	8-5/8	97-7/8	5	9	6	1-1/2	4	1290#
		10'	WSJ360-250-10-10	250	574#	135-1/4	12-3/4	8-5/8	88-7/8	5	12	6	1-1/2	4	1710#
		12'	WSJ360-250-10-12	500	607#	138-1/4	12-3/4	8-5/8	79-7/8	7-1/8	15	36	2-7/8	6	900#
		14'	WSJ360-250-10-14	500	658#	137-3/4	16-1/4	8-5/8	79-7/8	7-1/8	15	36	2-7/8	6	1130#
		16'	WSJ360-250-10-16	500	706#	137-3/4	16-1/4	8-5/8	79-7/8	7-1/8	15	36	2-7/8	6	1360#
	12'	8'	WSJ360-250-12-8	250	580#	156-1/4	9-3/4	8-5/8	121-7/8	5	9	6	1-1/2	4	1280#
		10'	WSJ360-250-12-10	250	618#	159-1/4	12-3/4	8-5/8	112-7/8	5	12	6	1-1/2	4	1700#
		12'	WSJ360-250-12-12	500	651#	162-1/4	15-3/4	8-5/8	103-7/8	7-1/8	15	36	2-7/8	6	890#
		14'	WSJ360-250-12-14	500	702#	161-3/4	16-1/4	8-5/8	103-7/8	7-1/8	15	36	2-7/8	6	1120#
		16'	WSJ360-250-12-16	500	891#	161-3/4	16-1/4	12-3/4	103-7/8	7-1/8	15	36	2-7/8	6	1310#
500#	8'	8'	WSJ360-500-8-8	500	518#	111-1/4	12-3/4	8-5/8	64-7/8	7-1/8	12	36	2-7/8	6	1030#
		10'	WSJ360-500-8-10	500	640#	111-1/4	12-5/8	12-3/4	64-7/8	7-1/8	12	36	2-7/8	6	1350#
		12'	WSJ360-500-8-12	500	676#	114-1/4	15-5/8	12-3/4	55-7/8	7-1/8	15	36	2-7/8	6	1710#
		14'	WSJ360-500-8-14	1000	962#	116-1/4	16-1/4	12-3/4	58-3/8	7-7/8	17-1/2	48	3-1/8	6	2140#
		16'	WSJ360-500-8-16	1000	1005#	116-1/4	16-1/4	12-3/4	58-3/8	7-7/8	17-1/2	48	3-1/8	6	2530#
	10'	8'	WSJ360-500-10-8	500	563#	135-1/4	12-3/4	8-5/8	88-7/8	7-1/8	12	36	2-7/8	6	1020#
		10'	WSJ360-500-10-10	500	707#	135-1/4	12-5/8	12-3/4	88-7/8	7-1/8	12	36	2-7/8	6	1340#
		12'	WSJ360-500-10-12	500	743#	138-1/4	15-5/8	12-3/4	79-7/8	7-1/8	15	36	2-7/8	6	1690#
		14'	WSJ360-500-10-14	1000	1004#	140-1/4	16-1/4	12-3/4	82-3/8	7-7/8	17-1/2	48	3-1/8	6	2120#
		16'	WSJ360-500-10-16	1000	1047#	140-1/4	16-1/4	12-3/4	82-3/8	7-7/8	17-1/2	48	3-1/8	6	2520#
	12'	8'	WSJ360-500-12-8	500	749#	159-1/4	12-5/8	12-3/4	112-7/8	7-1/8	12	36	2-7/8	6	980#
		10'	WSJ360-500-12-10	500	773#	159-1/4	12-5/8	12-3/4	112-7/8	7-1/8	12	36	2-7/8	6	1320#
		12'	WSJ360-500-12-12	500	810#	162-1/4	15-5/8	12-3/4	103-7/8	7-1/8	15	36	2-7/8	6	1680#
		14'	WSJ360-500-12-14	1000	1046#	164-1/4	16-1/4	12-3/4	106-3/8	7-7/8	17-1/2	48	3-1/8	6	2110#
		16'	WSJ360-500-12-16	1000	1309#	165-1/4	16-5/8	14	106-3/8	7-7/8	17-1/2	48	3-1/8	6	1880#
1000#	8'	8'	WSJ360-1000-8-8	1000	631#	111-1/4	12-5/8	12-3/4	64-7/8	7-7/8	12	48	3-1/8	6	2080#
		10'	WSJ360-1000-8-10	1000	702#	114-1/4	15-5/8	12-3/4	56-7/8	7-7/8	15	48	3-1/8	6	2690#
		12'	WSJ360-1000-8-12	1000	728#	116-1/4	15-5/8	12-3/4	57-7/8	7-7/8	17	48	3-1/8	6	3370#
		14'	WSJ360-1000-8-14	2000	1202#	118-3/4	18-5/8	14	40	8-1/8	20	48	2-7/8	6	3210#
		16'	WSJ360-1000-8-16	2000	1271#	118-3/4	18-5/8	14	40	8-1/8	20	48	2-7/8	6	3800#
	10'	8'	WSJ360-1000-10-8	1000	698#	135-1/4	12-5/8	12-3/4	88-7/8	7-7/8	12	48	3-1/8	6	2020#
		10'	WSJ360-1000-10-10	1000	768#	138-1/4	15-5/8	12-3/4	80-7/8	7-7/8	15	48	3-1/8	6	2680#
		12'	WSJ360-1000-10-12	1000	795#	140-1/4	15-5/8	12-3/4	81-7/8	7-7/8	17	48	3-1/8	6	3350#
		14'	WSJ360-1000-10-14	2000	1264#	142-3/4	18-5/8	14	64	8-1/8	20	48	2-7/8	6	3180#
		16'	WSJ360-1000-10-16	2000	1337#	142-3/4	18-5/8	14	64	8-1/8	20	48	2-7/8	6	3770#
	12'	8'	WSJ360-1000-12-8	1000	765#	159-1/4	12-5/8	12-3/4	112-7/8	7-7/8	12	48	3-1/8	6	2000#
		10'	WSJ360-1000-12-10	1000	835#	162-1/4	15-5/8	12-3/4	104-7/8	7-7/8	15	48	3-1/8	6	2670#
		12'	WSJ360-1000-12-12	1000	862#	164-1/4	15-5/8	12-3/4	105-7/8	7-7/8	17	48	3-1/8	6	3340#
		14'	WSJ360-1000-12-14	2000	1399#	166-3/4	18-5/8	14	88	8-1/8	20	48	2-7/8	6	3160#
		16'	WSJ360-1000-12-16	2000	1548#	166-3/4	18-5/8	16	88	8-1/8	20	48	2-7/8	12	1510#

Additional Sizes and Capacities Readily Available

Other spans, heights, and capacities are available by contacting your local Gorbel® dealer.

Note: Dimensions are subject to change without notice.

WSJ200 Wall Cantilever Work Station Jibs: 200° Rotation

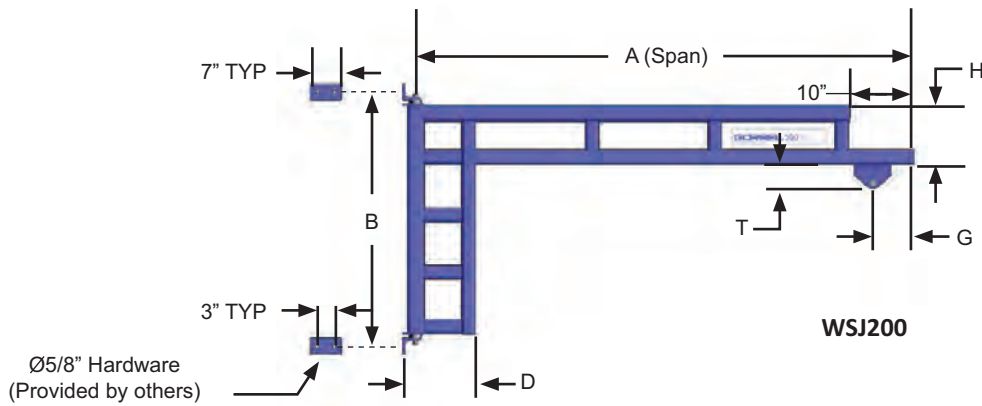

CAPACITY	SPAN (A)	MODEL NUMBER	TRACK SERIES	WEIGHT	B	D	G	H	T	THRUST & PULL
					in	in	in	in	in	
150#	8'	WSJ200-150-8	250	160#	36	10-3/8	5	9	1-1/2	612#
	10'	WSJ200-150-10	250	181#	36	10-3/8	5	9	1-1/2	801#
	12'	WSJ200-150-12	250	216#	48	13-3/8	5	12	1-1/2	750#
	14'	WSJ200-150-14	500	282#	60	16-7/8	7-1/8	15	2-7/8	782#
	16'	WSJ200-150-16	500	330#	60	16-7/8	7-1/8	15	2-7/8	932#
250#	8'	WSJ200-250-8	250	160#	36	10-3/8	5	9	1-1/2	962#
	10'	WSJ200-250-10	250	198#	48	13-3/8	5	12	1-1/2	933#
	12'	WSJ200-250-12	500	252#	60	16-3/8	7-1/8	15	2-7/8	945#
	14'	WSJ200-250-14	500	282#	60	16-7/8	7-1/8	15	2-7/8	1160#
	16'	WSJ200-250-16	500	330#	60	16-7/8	7-1/8	15	2-7/8	1366#
500#	8'	WSJ200-500-8	500	188#	48	13-3/8	7-1/8	12	2-7/8	1390#
	10'	WSJ200-500-10	500	213#	48	13-3/8	7-1/8	12	2-7/8	1784#
	12'	WSJ200-500-12	500	252#	60	16-3/8	7-1/8	15	2-7/8	1750#
	14'	WSJ200-500-14	1000	384#	60	16-7/8	7-7/8	17-1/2	3-1/8	2152#
	16'	WSJ200-500-16	1000	416#	60	16-7/8	7-7/8	17-1/2	3-1/8	2512#
1000#	8'	WSJ200-1000-8	1000	204#	48	13-3/8	7-7/8	12	3-1/8	2722#
	10'	WSJ200-1000-10	1000	274#	60	16-3/8	7-7/8	15	3-1/8	2781#
	12'	WSJ200-1000-12	1000	301#	60	16-3/8	7-7/8	17	3-1/8	3394#
	14'	WSJ200-1000-14	2000	546#	72	18-7/8	8-1/8	20	2-7/8	3451#
	16'	WSJ200-1000-16	2000	595#	72	18-7/8	8-1/8	20	2-7/8	4010#

Additional Sizes and Capacities Readily Available
Other spans, heights, and capacities are available by contacting your local Gorbel® dealer.

Note: Dimensions are subject to change without notice.

Accessories for Work Station Jib Cranes

Festooning

Festoon Saddle: Gorbel's Tool Solution saddles were designed for applications that require festooning of cables and hoses. The arched saddle with the option of angled mounting creates a very clean, efficient way to manage your cables and wires.

Saddles are available in 3 and 6 inch diameters for various sized festooning with a 75 pound capacity per saddle. The universal mounting plate allows for the saddle to hang in line with the track, or at a 30° angle to assist the cable in self-coiling, taking up less track space and allowing more room for end approach.



Festoon Gliders are used to support flat electrical cable along the jib boom. No tools are required to attach the festooning to the gliders. *Not available for AL100 jibs.*



Festoon Trolleys are used to support flat cable, air hose or round cable along the jib boom. The trolleys have four wheels and a pivoting festoon saddle support.

Enclosed Track Jibs

AL100 Wall Bracket Work Station Jibs: 200° Rotation

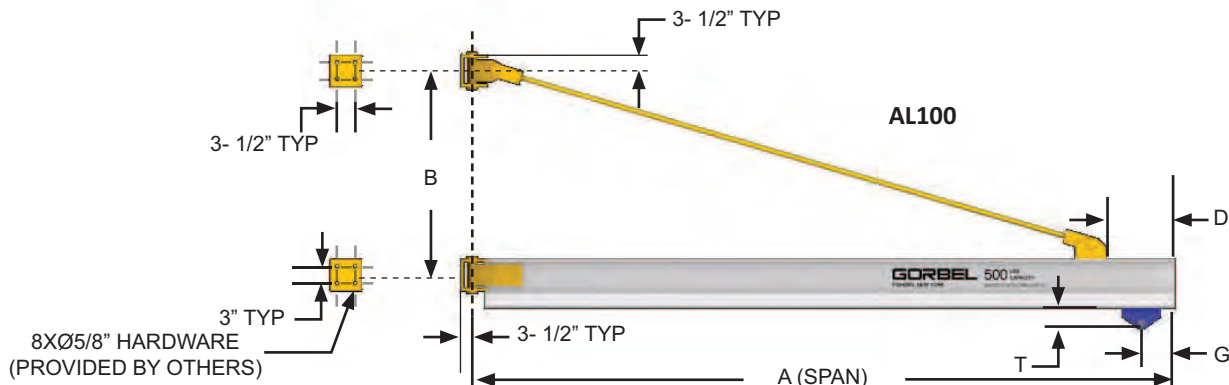

CAPACITY	SPAN (A)	MODEL NUMBER	TRACK SERIES	WEIGHT	B	D	G	T	TIE ROD DIAMETER	THRUST & PULL
					in	in	in	in		
250#	8'	AL100-G1-250-8	A0250	165#	24	18	7-1/4	2-5/8	1"	1377#
	10'	AL100-G1-250-10	A0250	178#	27	21	7-1/4	2-5/8	1"	1567#
	12'	AL100-G1-250-12	A0250	190#	30	24	7-1/4	2-5/8	1"	1725#
	14'	AL100-G1-250-14	A0250	203#	33	27	7-1/4	2-5/8	1"	1861#
	16'	AL100-G1-250-16	A0250	216#	36	30	7-1/4	2-5/8	1"	1979#
500#	8'	AL100-G1-500-8	A0500	173#	36	18	7-1/4	2-5/8	1"	1800#
	10'	AL100-G1-500-10	A0500	187#	42	21	7-1/4	2-5/8	1"	1967#
	12'	AL100-G1-500-12	A0500	202#	48	24	7-1/4	2-5/8	1"	2097#
	14'	AL100-G1-500-14	A0500	217#	54	27	7-1/4	2-5/8	1"	2202#
	16'	AL100-G1-500-16	A0500	231#	60	30	7-1/4	2-5/8	1"	2290#
1000#	8'	AL100-G1-1000-8	A1000	203#	30	18	7-7/8	2-7/8	1"	4306#
	10'	AL100-G1-1000-10	A1000	225#	33	21	7-7/8	2-7/8	1"	4987#
	12'	AL100-G1-1000-12	A1000	246#	36	24	7-7/8	2-7/8	1"	5566#
	14'	AL100-G1-1000-14	A1000	268#	39	27	7-7/8	2-7/8	1"	6066#
	16'	AL100-G1-1000-16	A1000	289#	42	30	7-7/8	2-7/8	1"	6504#
2000#	8'	AL100-G1-2000-8	A2000	231#	48	18	12-7/8	2-7/8	1"	4982#
	10'	AL100-G1-2000-10	A2000	256#	54	21	12-7/8	2-7/8	1"	5713#
	12'	AL100-G1-2000-12	A2000	280#	60	24	12-7/8	2-7/8	1"	6307#
	14'	AL100-G1-2000-14	A2000	305#	66	27	12-7/8	2-7/8	1"	6800#
	16'	AL100-G1-2000-16	A2000	330#	75	30	12-7/8	2-7/8	1"	6929#

Additional Sizes and Capacities Readily Available

Other spans, heights, and capacities are available by contacting your local Gorbel® dealer.

Note: Dimensions are subject to change without notice.

Trolley Options



Light Tool Trolley: Designed specifically for suspended small tools, the light tool trolley features a six wheel design with the center wheel positioned slightly higher to prevent binding when force is applied at an angle. The short

wheel base allows for multiple trolleys to be used in a small area, making this trolley ideal for hanging tooling with spring balancers that require side loading capabilities. This trolley fits 250 series track in capacities up to 75 lbs.



Heavy Tool Trolley: The heavy tool trolley features six wheels with the center axis set higher to prevent binding. With a higher capacity and longer body profile, this trolley fits 500 series track in capacities up to 125

lbs., and can be used for suspending tools or festooning. An optional swivel attachment can be added to the bottom edge to support festooning of electrical, air or vacuum tube.

Rotation Options

Four Ring Electrical Collector (*Top or Bottom Entry - not shown*) Provides continuous 360° rotation of the boom when using an electrical lifting device. The top entry collector requires 11 ¼" additional clearance height

Air Swivel (*Top or Bottom Entry - not shown*) Provides continuous 360 rotation of the boom when using an air powered lifting device. A top entry collector require 5" of additional clearance above the pivot pin. The bottom entry collector requires 8 ½ to 9 ½ inches above the pivot pin depending on span and capacity.

Manual Rotation Stops (*not shown*): To prevent boom damage to machines, equipment, or building structures, rotation stops can be used to the limit the WSJ360 rotation to less than 360°.

Tool Solution Jib Cranes

Tool Solution Jib Cranes use Gorbel's enclosed track to provide effortless movement and high productivity in work cells. Each jib is designed to be a durable, lightweight and cost effective solution for applications with suspended tools or light duty lifting.

TSJ50: 50 Pound Capacity



The TSJ50 is designed for easy movement of light loads. Its lightweight tie rod style insures easy movement and high performance without giving you more crane than you need for low capacity applications.

With a slim profile and simple installation, the TSJ50 excels in tight work spaces. The small bracket centers of 13-3/16 inches make it ideal for low headroom applications. For free standing models, the crane's slim 4 inch square mast allows installation without a foundation where floor space may be limited. The four-bolt mounting brackets allow for easy adjustment of the boom height, and make conversion to wall or column mounting a simple task.

- Standard spans to 10 feet
- Available as wall or floor mounted
- Up to 180 degrees of rotation
- Uses 250 Series Track
- Free Standing Height Under Boom to 10 feet
- **Available Options:** Rotation lock/adjustable friction brake

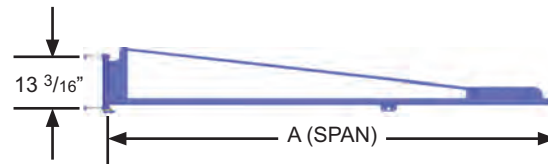
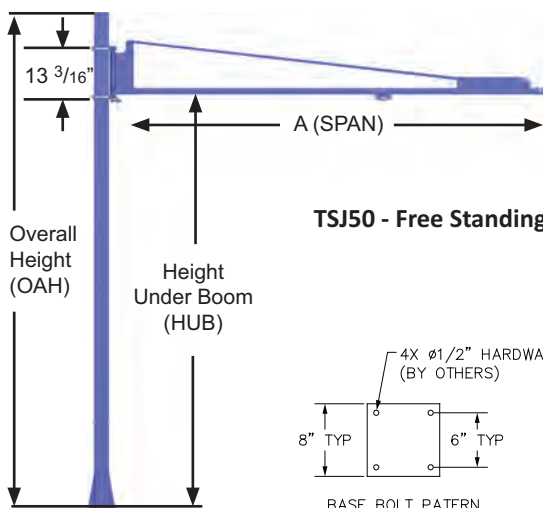

TSJ50 - Free Standing

TSJ50 - Wall/Column Mounted

CAPACITY	SPAN (A)	MODEL NUMBER
50#	4'	TSJ50-WM-50-4
	6'	TSJ50-WM-50-6
	8'	TSJ50-WM-50-8
	10'	TSJ50-WM-50-10

CAPACITY	HUB	SPAN (A)	MODEL NUMBER	OAH
50#	8'	4'	TSJ50-FS-50-8-4	9-1/4"
		6'	TSJ50-FS-50-8-6	9-1/4"
		8'	TSJ50-FS-50-8-8	9-1/4"
		10'	TSJ50-FS-50-8-10	9-1/4"
	10'	4'	TSJ50-FS-50-10-4	11-1/4"
		6'	TSJ50-FS-50-10-6	11-1/4"
		8'	TSJ50-FS-50-10-8	11-1/4"
		10'	TSJ50-FS-50-10-10	11-1/4"

Rotation Lock/Adjustable Friction Brake (TSJ50 Only):

The rotation lock allows you to securely lock the boom of the crane in position for storage. The lock features a spring loaded bit that fits into any of 9 positions within the 180° rotation when engaged.



TSJ150: 150 Pound Capacity



For heavier or higher impact applications, Gorbel offers the TSJ150. The lightweight design makes this higher capacity tool jib easy to operate as either a free standing or a column/wall mounted style.

The slim profile of the TSJ150 features bracket centers of only 19-1/2 inches, making it ideal for applications with limited head room. Installing a free standing model in a crowded workspace is made easier with this jib, which does not require a special foundation.

Free standing jib cranes require a 6 inch reinforced concrete floor.

- Standard spans to 12 feet
- Available as wall or floor mounted
- Up to 200 degrees of rotation
- Uses 250 Series Track
- Free Standing Height Under Boom to 10 feet
- **Available Options:** Adjustable friction brake

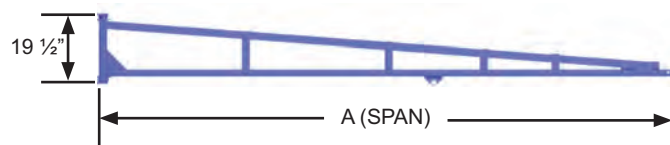
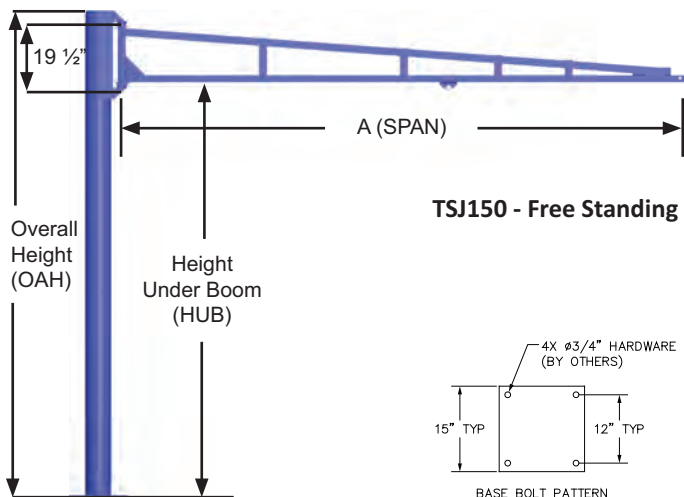

TSJ150 - Free Standing

TSJ150 - Wall/Column Mounted

CAPACITY	SPAN (A)	MODEL NUMBER
150#	4'	TSJ150-WM-150-4
	6'	TSJ150-WM-150-6
	8'	TSJ150-WM-150-8
	10'	TSJ150-WM-150-10
	12'	TSJ150-WM-150-12

CAPACITY	HUB	SPAN (A)	MODEL NUMBER	OAH
150#	8'	4'	TSJ150-FS-150-8-4	9-9/16"
		6'	TSJ150-FS-150-8-6	9-9/16"
		8'	TSJ150-FS-150-8-8	9-9/16"
		10'	TSJ150-FS-150-8-10	9-9/16"
		12'	TSJ150-FS-150-8-12	9-9/16"
	10'	4'	TSJ150-FS-150-10-4	11-9/16"
		6'	TSJ150-FS-150-10-6	11-9/16"
		8'	TSJ150-FS-150-10-8	11-9/16"
		10'	TSJ150-FS-150-10-10	11-9/16"
		12'	TSJ150-FS-150-10-12	11-9/16"

Portable Base: Our optional portable base provides a stable base that can be moved easily within your facility. The square steel plate allows you to secure and level your jib with mast mounting hardware and leveling feet. It also features fork pockets for easy relocation by fork truck or pallet jack.



See page 27 for dimensional information.

Articulating Jib Cranes

Ideal for reaching in, around and under

Gorbel® Articulating Jib Cranes can position loads in places you cannot reach with traditional jibs. They provide easy rotation and consistent responsiveness when positioning loads throughout the crane's coverage area. Gorbel® Wall/Column Mounted Articulating Jibs can handle up to 200° rotation for the primary boom and up to 360° for the secondary boom. Gorbel's Free Standing and Ceiling Mounted Articulating Jibs can rotate up to 360° on the primary and secondary booms.

Gorbel's Advantage

Easy Movement

Traditional jib cranes can be difficult to rotate when the load is on the inner half of the boom. The articulating jibs are easier to rotate in close to the free standing mast or building column.

Precise Load Positioning

Gorbel® Articulating Jib Cranes are A Class Above™ when it comes to positioning and spotting loads around an obstruction, through an open doorway, or rotating in close to the free standing mast or building column.

Wide Variety of Spans and Capacities

Gorbel® Articulating Jib Cranes are available as standard products in capacities up to 2000 lbs. and spans up to 16' without the extra lead time and costs associated with customization.



Easy Movement Throughout The Coverage Area

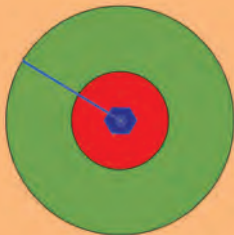

Traditional Jib Coverage

With a traditional jib crane, placement near the mast of the jib becomes difficult due to the weight of the jib boom.



Articulating Jib Coverage

The articulating arm allows easy movement of the load throughout the coverage area.

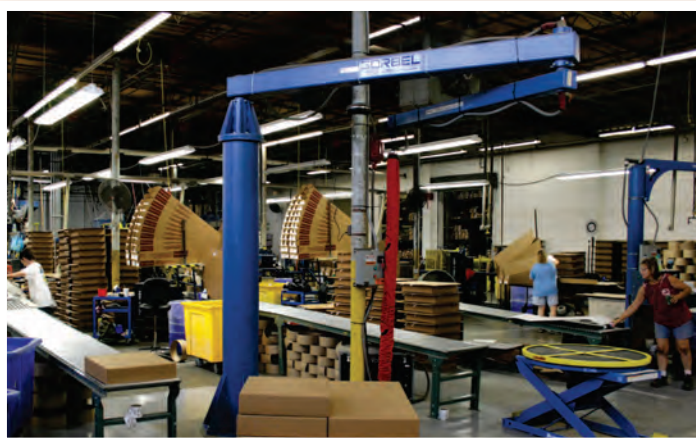

AJ360-F Free Standing Articulating Jib Crane

The AJ360-F is perfect for applications that demand the use of an articulating jib, but there are no walls or columns to mount the crane. This crane offers effortless rotation and a consistent responsiveness when positioning loads in a work cell, through open doorways, or into machines. See pages 22-23 for details.

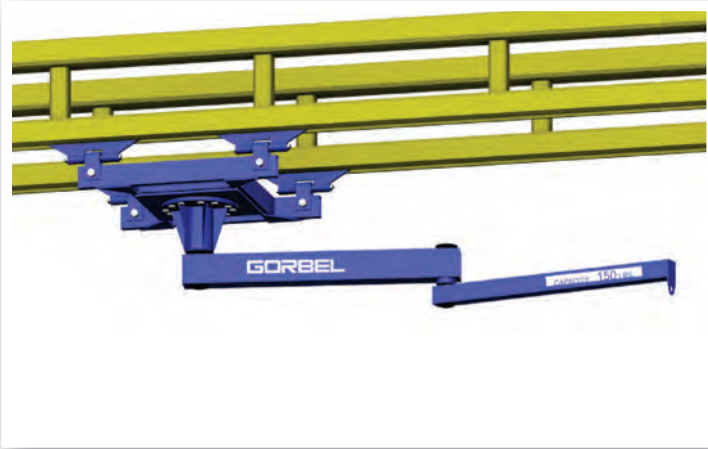

AJ360-C Ceiling Mounted Articulating Jib Crane

The AJ360-C is mounted overhead leaving nothing to disrupt workflow in the production area below. The AJ360-C can be stationary mounted or platform supported from a Gorbels® Work Station Dual Girder Bridge Crane, which allows usage outside the normal coverage of a bridge crane or the jib to swing under obstructions. With the jib mounted to a platform, multiple work cells can be covered with just one crane and lifting device. See page 24 for details.



AJ200 Wall/Column Mounted Articulating Jib Crane

The AJ200 is perfect for applications that require maneuvering under obstructions or around obstacles and there is an adequate wall/column to support the crane. See page 24 for details.

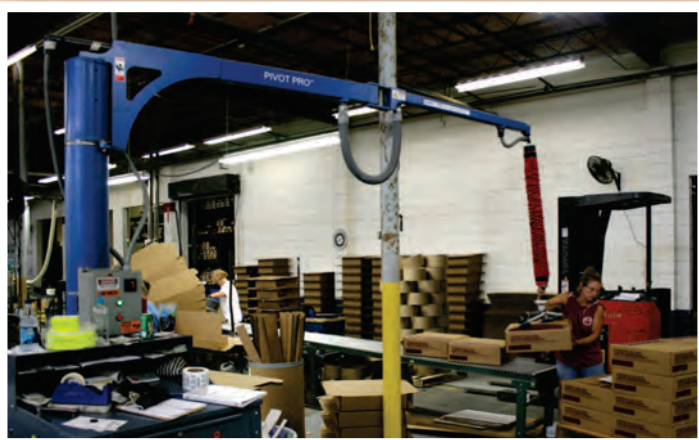

PIVOT PRO® Wall Mounted or Free Standing Vacuum Sealed Articulating Jib Crane

The PIVOT PRO® is great for vacuum lifting applications or lighter capacity applications where an articulated arm would be beneficial. For vacuum lifting, the PIVOT PRO® features vacuum sealed arms to reduce hose festooning. See pages 25-27 for details.

AJ360 Free Standing Articulating Jib Cranes: 360° Rotation

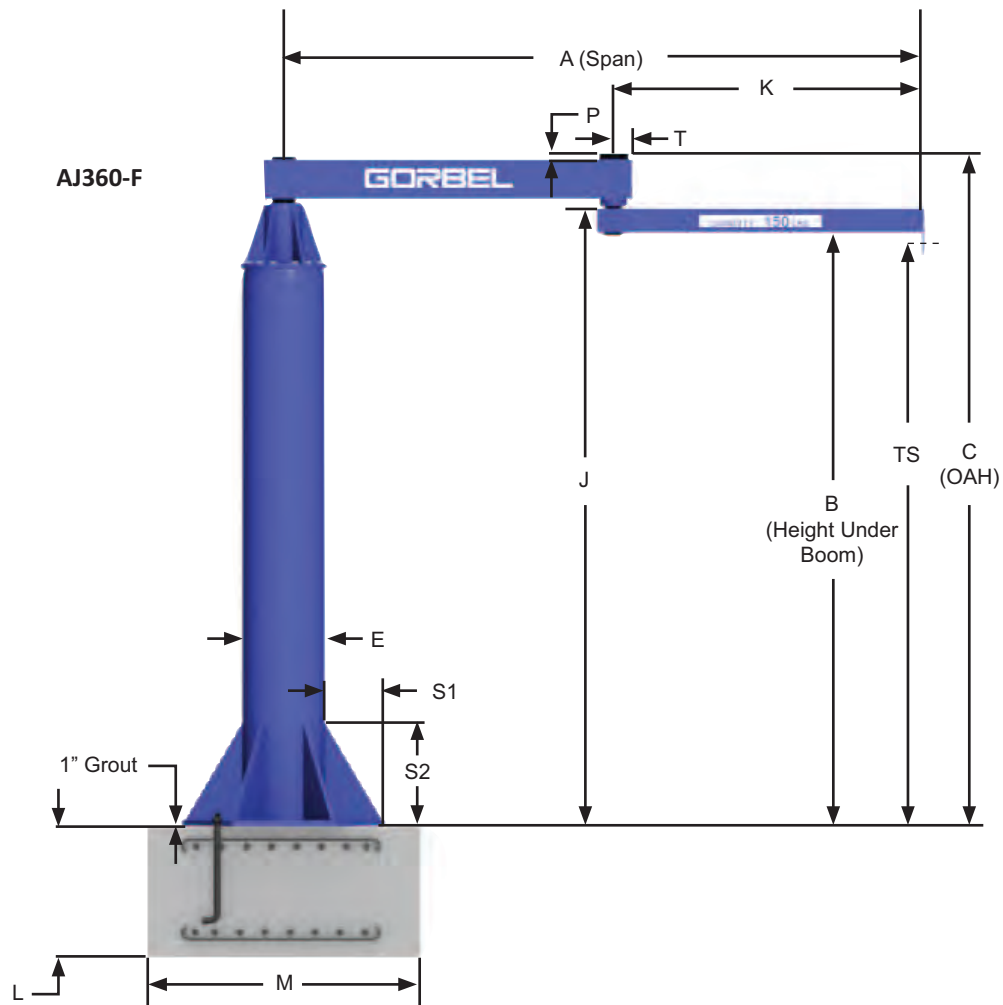

E (Pipe Size)	8"	12"	14"	16"	18"	20"	24"
Number of Ancho Bolts	6	6	6	12	12	12	12
Diameter (D)	1"	1.25"	1.25"	1.25"	1.25"	1.25"	1.25"
Bolt Circle (Q)	24"	24"	30"	36"	42"	48"	54"

Jib crane foundation requirements are based on soil pressure of 2500# per square foot. Concrete recommended for jib crane foundation is 3000# per square inch of compressive force.

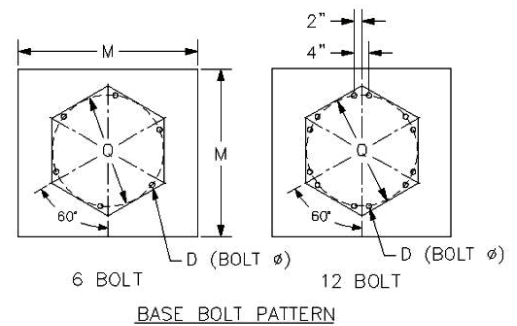

Note: Gorbel® Articulating Jib Cranes REQUIRE ONE of the following when using a powered lifting device:

1. Electric Lifting Devices - Require either: *Rotation stops to limit boom and/or arm rotation to <360° or Collectors when 360° rotation is required.
2. Air Lifting Devices - Require either: *Rotation stops to limit boom and/or arm rotation to <360° or Air Swivels when 360° rotation is required.
3. Vacuum Lifting Devices: *Rotation stops to limit boom and/or arm rotation to <360°.
*Rotation stops require field welding.

Figure A - AJ360 Ceiling Mounted

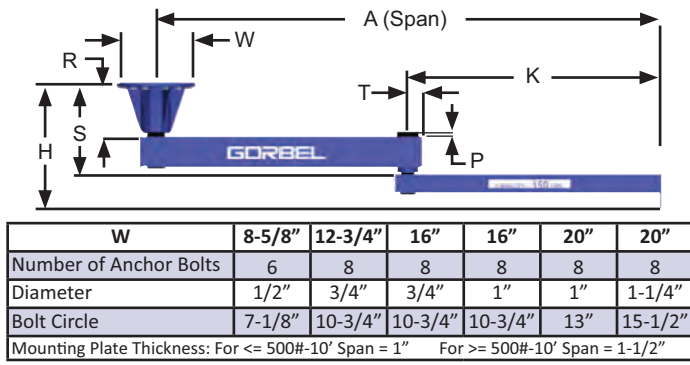
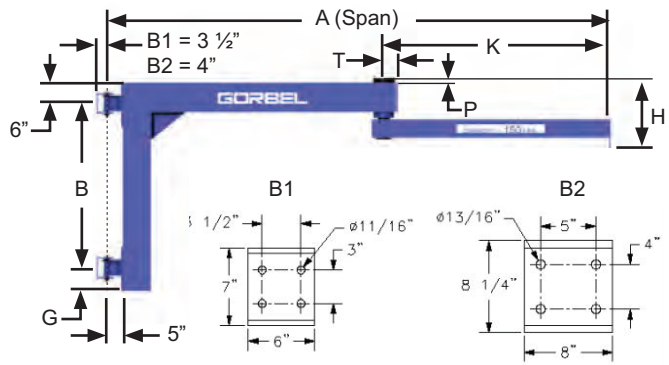

Figure B - AJ200 Wall Mounted



AJ360 Ceiling Mounted Articulating Jib Cranes: 360° Rotation (Figure A)

CAPACITY	SPAN (A)	MODEL NUMBER	WEIGHT	K	T	P	H	R	S	W	BOLT QTY.	ANCHOR BOLT LOAD	OTM kip-ft.
				in	in	in	in	in	in				
250#	8'	AJ360-C-250-8	340#	36	3-5/16	1	29-7/16	11-13/16	19-15/16	12-3/4	8	1140#	3.37
	10'	AJ360-C-250-10	440#	48	3-15/16	1-3/4	29-3/16	11-13/16	21-11/16	12-3/4	8	1590#	4.64
	12'	AJ360-C-250-12	540#	60	3-15/16	1-3/4	31-7/8	14-1/2	24-3/8	16	8	1980#	5.73
	14'	AJ360-C-250-14	575#	72	3-15/16	1-3/4	31-7/8	14-1/2	24-3/8	16	8	2400#	6.88
	16'	AJ360-C-250-16	645#	84	3-15/16	1-1/4	32-3/8	14-1/2	24-7/8	16	8	2890#	8.22
500#	8'	AJ360-C-500-8	470#	36	3-15/16	1-3/4	31-7/8	14-1/2	24-3/8	16	8	2190#	6.40
	10'	AJ360-C-500-10	505#	48	3-15/16	1-3/4	31-7/8	14-1/2	24-3/8	16	8	2830#	8.14
	12'	AJ360-C-500-12	735#	60	4-11/16	1-3/8	35-3/8	16-3/8	26-7/8	16	8	3680#	10.54
	14'	AJ360-C-500-14	780#	72	4-11/16	1-3/8	35-3/8	16-3/8	26-7/8	16	8	4430#	12.57
	16'	AJ360-C-500-16	935#	84	4-15/16	1-11/16	37-11/16	16-3/8	29-3/16	16	8	5450#	15.39
1000#	8'	AJ360-C-1000-8	650#	36	4-11/16	1-3/8	35-3/8	16-3/8	26-7/8	16	8	4240#	12.32
	10'	AJ360-C-1000-10	780#	48	4-15/16	1-11/16	37-11/16	16-3/8	29-3/16	16	8	5590#	15.99
	12'	AJ360-C-1000-12	950#	60	4-15/16	1-11/16	39-1/8	17-13/16	30-5/8	20	8	5590#	19.43
	14'	AJ360-C-1000-14	1005#	72	4-15/16	1-11/16	39-1/8	17-13/16	30-5/8	20	8	6670#	22.97
	16'	AJ360-C-1000-16	1795#	84	5-7/16	1-5/8	41	15-3/4	30-1/2	20	8	6840#	28.58
2000#	8'	AJ360-C-2000-8	850#	36	4-15/16	1-11/16	39-1/8	17-13/16	30-5/8	20	8	6730#	23.84
	10'	AJ360-C-2000-10	1285#	48	5-7/16	1-5/8	41	15-3/4	30-1/2	20	8	7320#	31.00
	12'	AJ360-C-2000-12	1365#	60	5-7/16	1-5/8	41	15-3/4	30-1/2	20	8	8990#	37.53
	14'	AJ360-C-2000-14	1445#	72	5-7/16	1-5/8	41	15-3/4	30-1/2	20	8	10700#	44.19
	16'	AJ360-C-2000-16	1620#	84	6-5/16	2-3/8	42-3/4	15-3/4	31-1/4	20	8	12610#	51.73

AJ200 Wall Mounted Articulating Jib Cranes: 200° Rotation (Figure B)

CAPACITY	SPAN (A)	MODEL NUMBER	WEIGHT	K	T	H	P	B	FITTING TYPE	THRUST & PULL
				in	in	in	in	in		
250#	8'	AJ200-B1-250-8	294#	36	3-5/16	15-5/8	1	36	B1	1120#
	10'	AJ200-B1-250-10	400#	48	3-15/16	19-1/8	1-3/4	36	B1	1550#
	12'	AJ200-B1-250-12	457#	60	3-15/16	19-1/8	1-3/4	48	B1	1430#
	14'	AJ200-B1-250-14	514#	72	3-15/16	19-1/8	1-3/4	60	B1	1380#
	16'	AJ200-B1-250-16	596#	84	3-15/16	19-1/8	1-3/4	60	B1	1640#
500#	8'	AJ200-B1-500-8	368#	33	3-15/16	19-1/8	1-3/4	36	B1	2140#
	10'	AJ200-B1-500-10	425#	45	3-15/16	19-1/8	1-3/4	48	B1	2040#
	12'	AJ200-B1-500-12	555#	57	4-11/16	19-5/16	1-3/8	60	B1	2050#
	14'	AJ200-B1-500-14	593#	69	4-11/16	19-5/16	1-3/8	60	B1	2430#
	16'	AJ200-B2-500-16	837#	81	4-15/16	23	1-11/16	60	B2	3090#
1000#	8'	AJ200-B1-1000-8	454#	33	4-11/16	19-5/16	1-3/8	48	B1	3050#
	10'	AJ200-B2-1000-10	649#	45	4-15/16	23	1-11/16	48	B2	4010#
	12'	AJ200-B2-1000-12	734#	57	4-15/16	23	1-11/16	60	B2	3900#
	14'	AJ200-B2-1000-14	785#	69	4-15/16	23	1-11/16	60	B2	4600#
	16'	AJ200-B2-1000-16	999#	81	5-7/16	27-7/8	2-5/8	72	B2	4660#
2000#	8'	AJ200-B2-2000-8	601#	30	4-15/16	23	1-11/16	48	B2	5980#
	10'	AJ200-B2-2000-10	779#	42	5-7/16	26-7/8	2-5/8	60	B2	6130#
	12'	AJ200-B2-2000-12	1156#	54	5-7/16	26-7/8	1-5/8	60	B2	7550#
	14'	AJ200-B2-2000-14	1382#	66	6-5/16	29-5/16	2-3/8	72	B2	7510#
	16'	AJ200-B2-2000-16	1466#	78	6-5/16	29-5/16	2-3/8	72	B2	8670#

Additional Sizes and Capacities Readily Available

Other spans and capacities are available by contacting your local Gorbel® dealer.

Note: Dimensions are for reference only and are subject to change without notice.

Base Price Includes: jib boom, jib arm, friction brakes, and clevis assembly for hook mounted lifting devices (lifting device by others).

AJ360-C price includes the assembly for ceiling mounting (anchor bolts by others). AJ200 price includes mounting brackets (hardware by others). Festooning is optional.

PIVOT PRO®

The PIVOT PRO® is a sleek new addition to the Gorbel® line of jib cranes. The PIVOT PRO® is an articulating jib that is specifically designed for applications under 150 lbs. Its smaller capacity allows it to have a lighter, less bulky design so it's easy to move. This lessens physical stress on workers, reduces employee injuries, and leads to increased efficiency.

Gorbel's Advantage

Ergonomic Design

The PIVOT PRO® can help you position loads in places you cannot reach with traditional jibs. It provides easy rotation and consistent responsiveness when positioning loads throughout the crane's coverage area. Our Free Standing PIVOT PRO® is capable of 360° non-continuous coverage around the mast, with the secondary arm covering 300°. The Wall Mounted model is capable of 200° rotation on the primary arm and 300° rotation with the secondary arm.

Easy Movement

Traditional jib cranes can be difficult to rotate when the load is on the inner half of the boom. The PIVOT PRO® is easier to rotate in close to the free standing mast or building column.

Rapid Return on Investment

Gorbel's PIVOT PRO® provides a rapid return on investment through increased productivity, reduced injuries, and improved safety. Increases in production result from the easy rotation of the boom and quick, precise load positioning. It is up to three times easier to start and stop the boom of a PIVOT PRO® compared to work station jib cranes. The result is reduced injury and improved safety. When you choose the PIVOT PRO®, you get a quality ergonomic product, a delivery date you can plan on, and the industry's best warranty.



"The PIVOT PRO® makes manipulating packages for palletizing so much easier. You don't have a lot of resistance from the boom to contend with when trying to place an object."

- Industrial Engineer for pump manufacturer

PIVOT PRO® Reduces Maintenance Costs

This customer was moving finished goods through a packaging line to prepare for shipping. The vacuum tube lifter they were using was constantly tearing and needing maintenance. Plus the operators were having difficulty moving the boxes the entire length of the old jib boom.

The PIVOT PRO® reduced the need for maintenance because the ease of movement caused less stress on the vacuum tube. After using the PIVOT PRO® on the application, the company purchased an additional unit for another application in the facility.



PIVOT PRO® Features & Benefits

Sealed Tube (1)

Our sealed tube eliminates the need for festooning in vacuum applications. No more festoon stack up, plus you get greater travel and minimize the potential for reduced vacuum suction caused by kinked hoses.

Articulated Boom Design (2)

- Moves up to 3 times easier than a work station jib
- Lighter weight makes positioning the loads easier
- Easier movement of loads close to the mast
- Safer operation by reducing the “whip” of the boom in high cycle applications
- Less boom “whip” reduces the wear and tear on vacuum lift tubes

Rotation Limits for Primary Arm (3)

The PIVOT PRO® has multiple rotation stop locations so you can tailor the coverage area to your needs.

Compatible with All Major OEM Tube Lifters (4)

Gorbel's PIVOT PRO® has been designed to be used with all major OEM manufacturers' vacuum tube lifters. (Note: Vacuum tube lifters by others).

No Foundation Required (5)

The PIVOT PRO® can bolt to any 6” reinforced concrete floor.

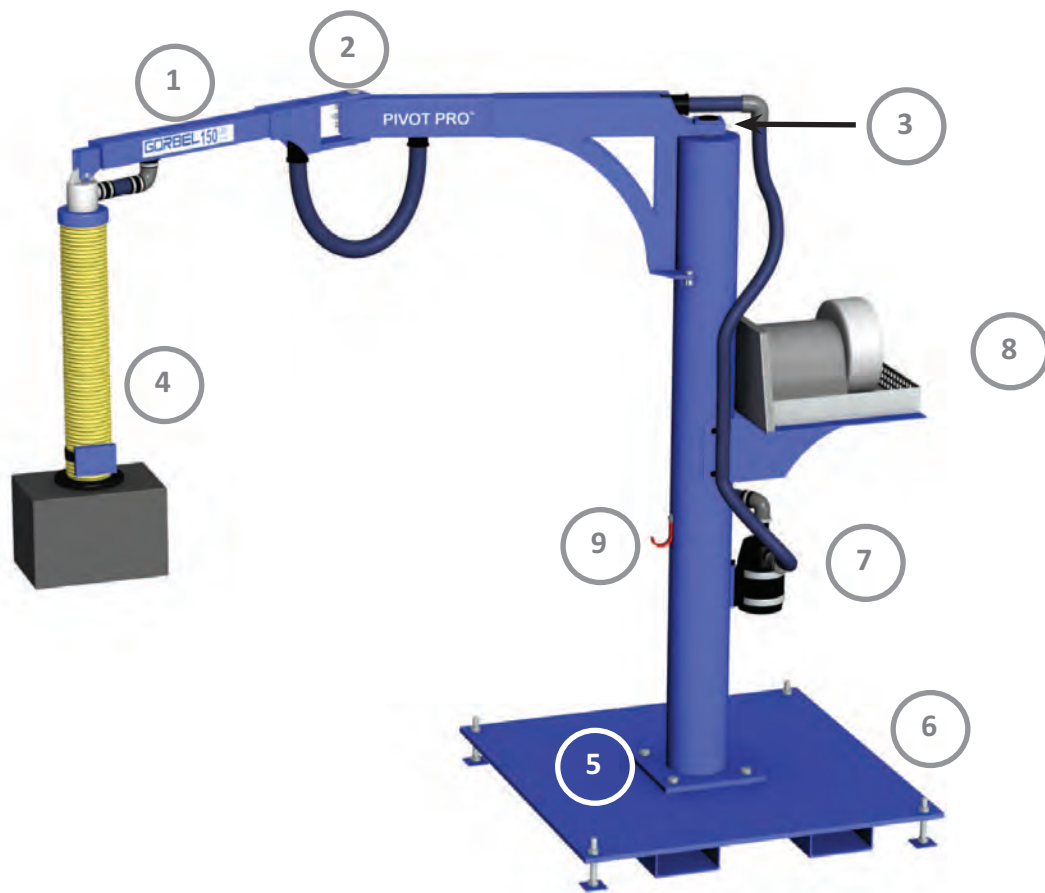

Optional Accessories for PIVOT PRO®

Portable Base (6)

Use the PIVOT PRO® throughout your plant when you choose our portable base. It's designed to accommodate small fork trucks and pallet jacks, and even comes with leveling feet. The base is sized for the capacity of the PIVOT PRO®.

Filter Bracket (7)

You can also choose to have us provide a filter bracket, and specify where on the PIVOT PRO® you want it placed.

Vacuum Pump with Platform (8)

We can also provide a platform that accommodates all the major OEM manufacturers' pumps. You specify where on the PIVOT PRO® mast you want the platform located.

Smart Hook (9)

When the PIVOT PRO® is not being used, this hook will keep your handle or end effector off the floor.

Articulating Jibs

Wall Mounted PIVOT PRO®

CAPACITY	SPAN (A)	MODEL NUMBER	SHIPPING WEIGHT	THRUST & PULL
50#	8'	PPRO-WM-50-8-T*	235#	584#
	10'	PPRO-WM-50-10-T*	250#	756#
	12'	PPRO-WM-50-12-T*	265#	941#
75#	8'	PPRO-WM-75--8-T*	235#	717#
	10'	PPRO-WM-75--10-T*	250#	921#
	12'	PPRO-WM-75--12-T*	265#	1139#
100#	8'	PPRO-WM-100--8-T*	235#	849#
	10'	PPRO-WM-100--10-T*	250#	1086#
	12'	PPRO-WM-100--12-T*	265#	1337#
150#	8'	PPRO-WM-150--8-T*	235#	1114#
	10'	PPRO-WM-150--10-T*	250#	1417#
	12'	PPRO-WM-150--12-T*	265#	1732#

* The "T" in the model number denotes vacuum hose at TOP of boom connection. Substitute a "B" in its place for the hose at the BOTTOM of boom connection.

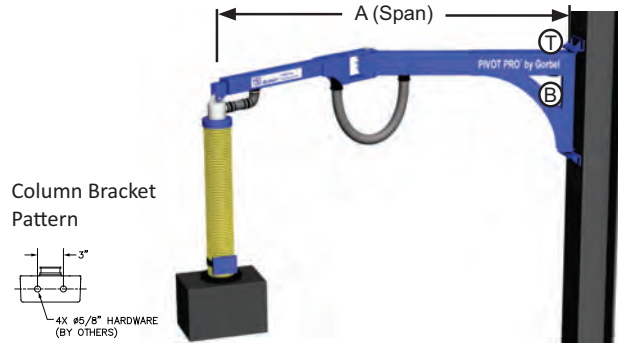

Column Bracket Pattern

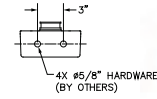

Includes: Jib boom assembly (primary and secondary arm), jib arm, pivot assemblies, friction brakes, vacuum hose between primary and secondary arm, hose fittings and mounting assembly (5/8" mounting hardware by others).

Free Standing PIVOT PRO®

CAPACITY	HUB	SPAN (A)	MODEL NUMBER	SHIPPING WEIGHT	ANCHOR BOLT LOAD
50#	10'	8'	PPRO-FS-50-10-8-T*	490#	528#
		10'	PPRO-FS-50-10-10-T*	505#	720#
		12'	PPRO-FS-50-10-12-T*	520#	927#
	12'	8'	PPRO-FS-50-12-8-T*	530#	517#
		10'	PPRO-FS-50-12-10-T*	545#	709#
		12'	PPRO-FS-50-12-12-T*	560#	916#
75#	10'	8'	PPRO-FS-75-10-8-T*	490#	668#
		10'	PPRO-FS-75-10-10-T*	505#	897#
		12'	PPRO-FS-75-10-12-T*	520#	1142#
	12'	8'	PPRO-FS-75-12-8-T*	530#	656#
		10'	PPRO-FS-75-12-10-T*	545#	885#
		12'	PPRO-FS-75-12-12-T*	560#	1131#
100#	10'	8'	PPRO-FS-100-10-8-T*	490#	807#
		10'	PPRO-FS-100-10-10-T*	505#	1074#
		12'	PPRO-FS-100-10-12-T*	520#	1356#
	12'	8'	PPRO-FS-100-12-8-T*	530#	796#
		10'	PPRO-FS-100-12-10-T*	545#	1063#
		12'	PPRO-FS-100-12-12-T*	560#	1345#
150#	10'	8'	PPRO-FS-150-10-8-T*	490#	1086#
		10'	PPRO-FS-150-10-10-T*	505#	1428#
		12'	PPRO-FS-150-10-12-T*	520#	1785#
	12'	8'	PPRO-FS-150-12-8-T*	530#	1075#
		10'	PPRO-FS-150-12-10-T*	545#	1417#
		12'	PPRO-FS-150-12-12-T*	560#	1774#

* The "T" in the model number denotes vacuum hose at TOP of boom connection. Substitute a "B" in its place for the hose at the BACK of boom connection (as shown).

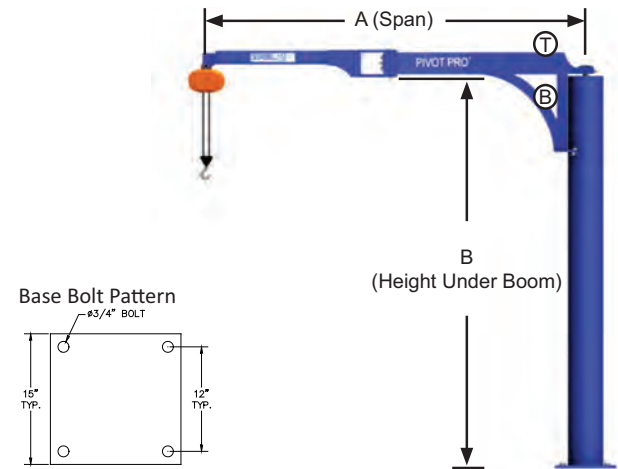

Base Bolt Pattern

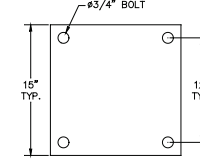

UNDER ARM HEIGHT	VACUUM HOSE LOCATION	OVERALL HEIGHT
10'	Top	10' 6-3/8"
12'	Top	12' 6-3/8"
10'	Back	10' 3-5/8"
12'	Back	12' 3-5/8"

Includes: Jib boom assembly (primary and secondary arm), jib arm, pivot assemblies, friction brakes, free standing mast, vacuum hose between primary and secondary arm, hose fittings, rotation stops and mounting assembly (3/4" anchor bolts by others).

Optional Portable Base

SPAN	CAPACITY	50#	75#	100#	150#
8'	Model Number	PB-48-10	PB-48-10	PB-48-12	PB-54-12
	Square Length	48"	48"	48"	54"
	Thickness	1"	1"	1.25"	1.25"
	Shipping Weight	696#	696#	858#	1098#
10'	Model Number	PB-48-10	PB-48-12	PB-54-12	PB-60-12
	Square Length	48"	48"	54"	60"
	Thickness	1"	1.25"	1.25"	1.25"
	Shipping Weight	696#	858#	1098#	1363#
12'	Model Number	PB-48-12	PB-54-12	PB-60-12	PB-60-15
	Square Length	48"	54"	60"	60"
	Thickness	1.25"	1.25"	1.25"	1.5"
	Shipping Weight	858#	1098#	1363#	1617#



Includes: Fork pockets, leveling feet, and mast mounting hardware.

Fork pocket dimensions = 7-1/4" inside width, 3-1/2" inside depth, and 20-1/2" from pocket centerline to centerline.

OVERVIEW BROCHURE



OVERVIEW DVD



CRANES



FREE STANDING



CEILING MOUNTED



GANTRY CRANES



CLEVELAND TRAMRAIL®



TOOL SOLUTIONS

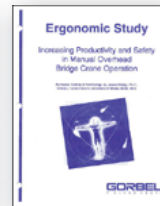

ERGONOMIC STUDY



INTERLOCK/
TRANSFER

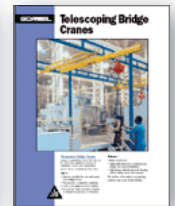

TELESCOPING

ERGONOMIC LIFTING



G-FORCE® &
EASY ARM®

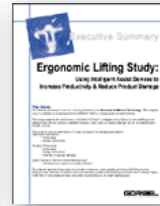

ERGONOMIC STUDY

FALL ARREST



TETHER TRACK™

FOR MORE INFORMATION

Your authorized Gorbels® dealer can give you more information on what makes Gorbels's Ergonomic Work Station Cranes and other material handling products "A Class Above."



COMPLETE METALWORKING SOLUTIONS
 (800) 991-4225 www.ahbinc.com
 ISO Certified customerservice@ahbinc.com



GORBEL®
 A CLASS ABOVE
 www.gorbel.com

GORBEL T 800.821.0086
 600 Fishers Run T 585.924.6262
 PO Box 593 F 585.924.6273
 Fishers, NY 14453 USA E info@gorbel.com