

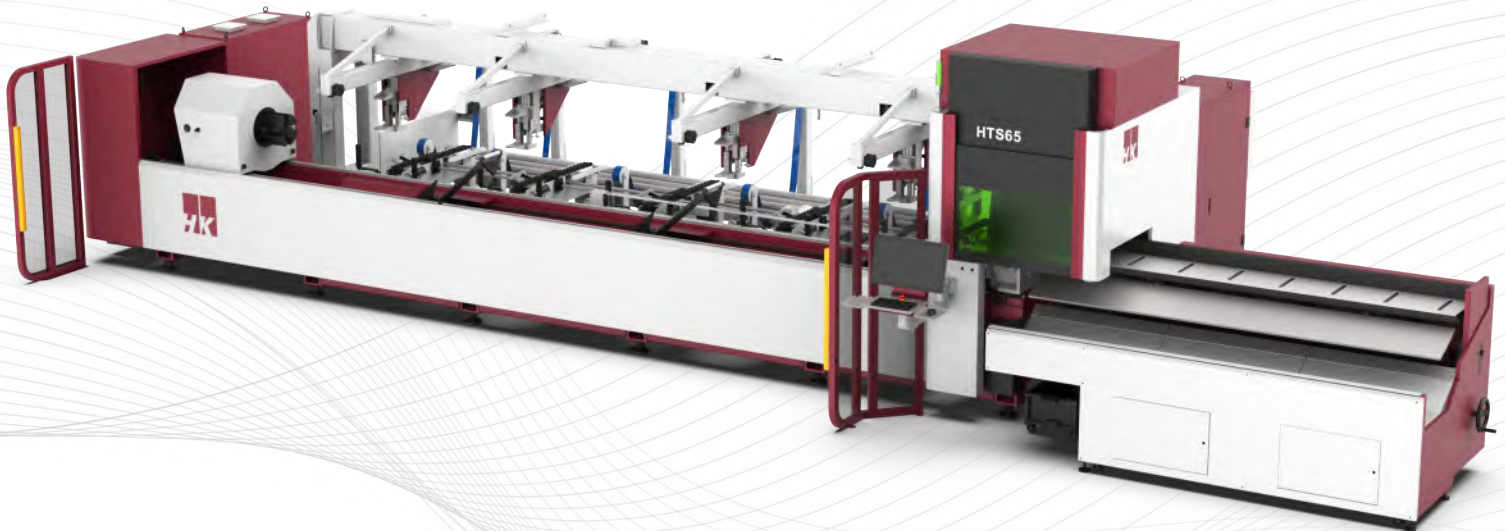

Fiber Laser | Tube Cutting | Automation



COMPLETE METALWORKING SOLUTIONS
(800) 991-4225 www.ahbinc.com
ISO Certified customerservice@ahbinc.com



TUBE LASER CUTTING SYSTEMS

hk-us.com





Branches

HK HEADQUARTES

South Korea

HK AMERICA

Chicago
Atlanta
Mexico
Brasil

HK EUROPE

Frankfurt

HK CHINA

Shanghai
Qingdao

HK TAIWAN

Taichung

HK VIETNAM

Ho Chi Minh

Dealers

AMERICA

Mexico
Canada
Brasil
Argentina
Chile

ASIA-PACIFIC

Thailand
Malaysia
Singapore
Indonesia
India
Phillipines

EUROPE

Russia CIS	Italy
Finland	France
Czech	UAE
Spain	Oman
Denmark	Hungary
Portugal	

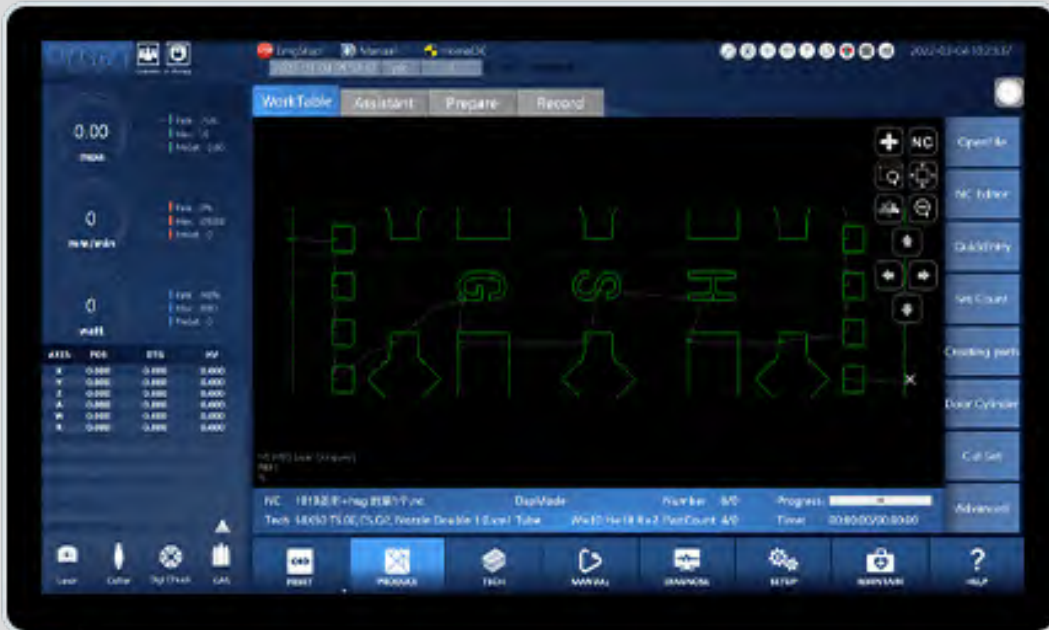

X9000 BUS CNC SYSTEM

- 21.5 inch touch screen
- Cutting process database
- Early warning system
- Real time monitoring system

Automatic Loading and Unloading Device



- Load and unload multiple or single tubes
- Semi-/full automatic equipment available to requests
- Fits both compact and heavy duty tube lasers

Chuck Clamping Technology

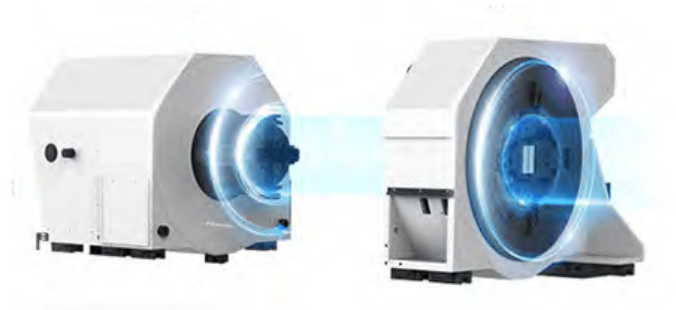

▶ Two Chucks

Pressure adjustments depending on tube diameter and thickness

Available for TL-S2, TL-S, TL-P, TL-X Plus Models

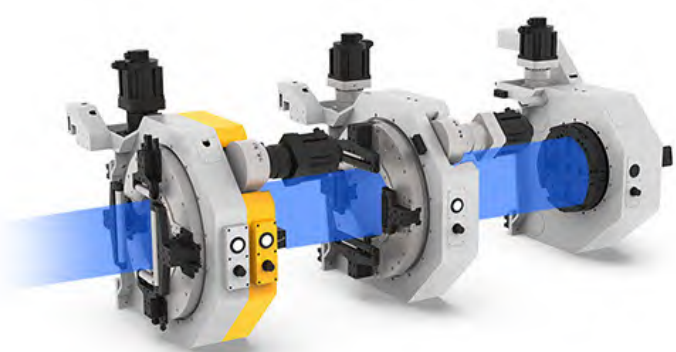

▶ Three Chucks

Chuck C3 and C4 are combined as one and rotate synchronously while controlling claws independently.

Available for TL-X models

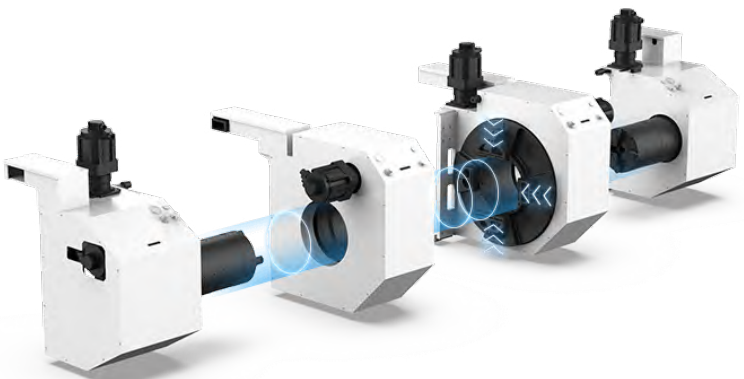

▶ Four Chucks

Four pneumatic chucks with a large clamping force for heavy and thick tubes.

Available for TL-L models

Tube Laser Line Up

Economic Solution
for tube cutting needs

TL-S2 Series



- Equipped with rectangular-circle pneumatic chucks
- Power from 1500 to 6000W for all cutting needs
- 21.5 inch touch screen with interface

Most Popular
solution with bundle loading system

TL-S Series

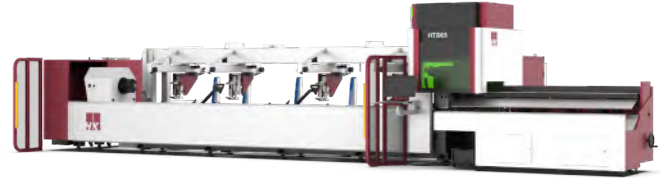

- High performance tube cutting solution with a complete automated bundle loading system
- Maximum diameter up to 10 inches and tube length up to 26 ft
- Digital chuck system that enables automatic clamping setup

Same features as TL-S Series
with bevel head

TL-P Series



- Includes same features as TL-S series
- Extra features include: 45 degree bevel cutting head

Most economic solution
for heavy duty application

TL-X Plus Series

Two chuck system



- Heavy duty with side mounted chuck system and automated front loading system
- Max diameter up to 12.7 inches (optional 13.7 inches) tube length up to 40ft



Heavy Duty Application for big structural beams (I/H/Angle beams)

TL-X Series

Three chuck system



- Heavy duty tube cutting with side mounted 3+1 Twin chucks
- Diameters up to 14.1 inches for structural I/H/Angle beams
- Maximum tube length up to 40 ft (optional 50 ft)

TL-L Series

Four chuck system



- Heavy duty tube cutting with four chucks with a full-scale automated loading/unloading system
- Diameters up to 20 inches
- Maximum tube length up to 40 ft (optional 50 ft)



TL-S2 Series



Details

Technical Details	TL-S2
Power	1.5-6kW
Rotating Speed of Chucks	100r/min
Round Tube	0.78-9.4 in
Rectangle	0.78*0.78 - 9.4*9.4 in
Single Tube Weight	440 lbs
Tailing Length	3.3 in
Dimensions (L*W*H)	41*15.4*8.2 ft

TL-S Series

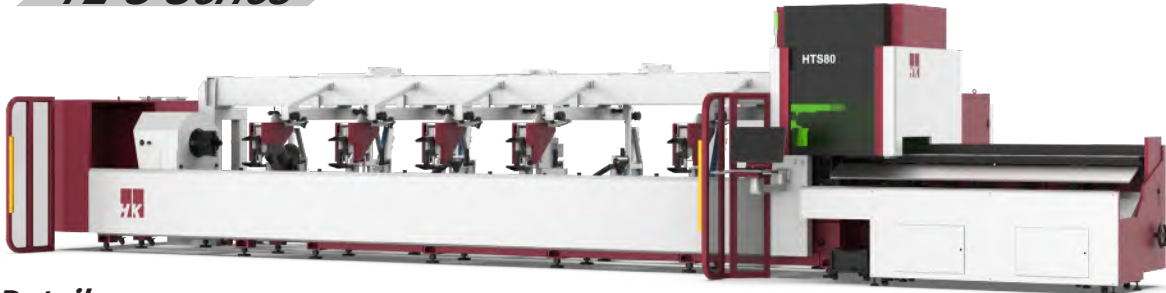

Details

Technical Details	TL6500-S	TL8000-S
Power	3-6kW	3-6kW
Rotating Speed of Chucks	120r/min	120r/min
Round Tube	0.5-10.7 in	0.5-10.7 in
Rectangle	.78*.78-7.8*7.8 in	0.5*0.5 - 7.8*7.8 in
Single Tube Weight	440 lbs	440 lbs
Tube Length	21 ft	26 ft
Dimensions (L*W*H)	46*17.3*8.2 ft	46*15.4*8.5 ft

TL-P Series

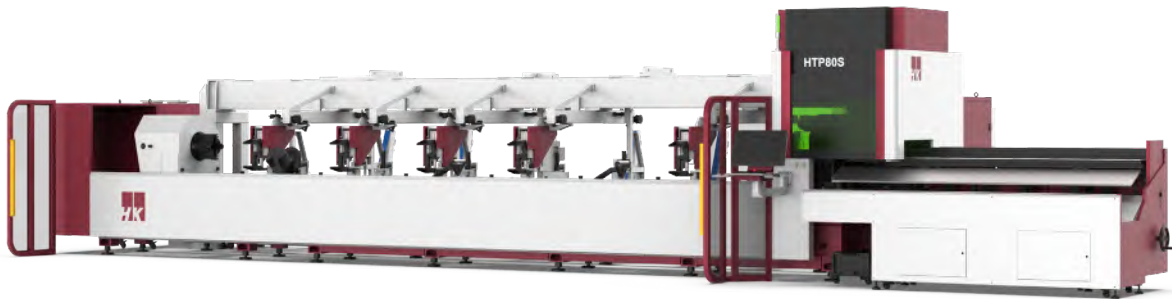

Details

Technical Details	TL6500-P	TL8000-P
Power	3-6kW	3-6kW
Rotating Speed of Chucks	120r/min	120r/min
Round Tube	0.78-10 in	0.78-10 in
Rectangle	0.5*0.5 - 7.8*7.8 in Rectangular Diagonal 10 in	0.5*0.5 - 7.8*7.8 in Rectangular Diagonal 10 in
Single Tube Weight	440 lbs	440 lbs
Tube Length	21 ft	26 ft
Dimensions (L*W*H)	41*15.4*8.5 ft	46*15.4*8.5 ft

TL-X Plus Series



Details

Technical Details	TL-X Plus	TL-X Plus II
Power	3-12kW	3-12kW
Rotating Speed of Chucks	80r/min	80r/min
Round Tube	0.78-12.7 in	0.78-13.7 in
Rectangle	.78*.78-9*9 in	0.78*0.78 - 13.8*13.8 in
Single Tube Weight	1322 lbs	1102 lbs
Tube Length	6500 - 21 ft 9000 - 30 ft 12000 - 39 ft	6500 - 21 ft 9000 - 30 ft 12000 - 39 ft

TL-X Series

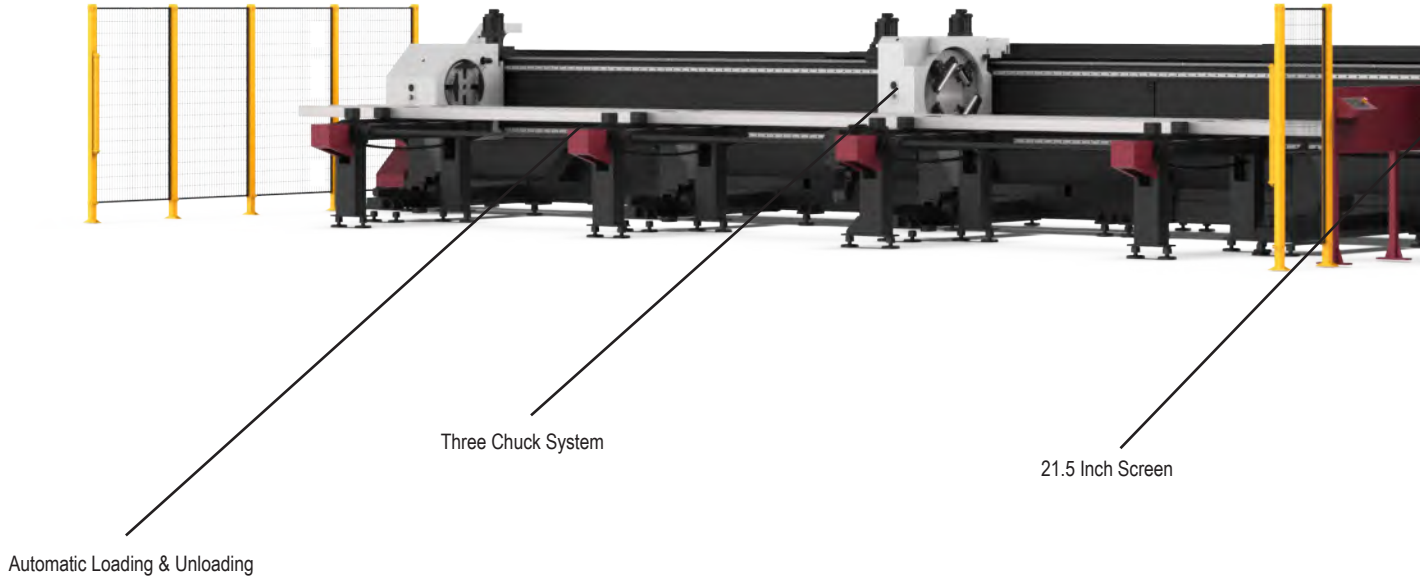

TL-L Series



The TL-L is equipped with four chucks to facilitate heavy-duty clamping. The four chucks give the needed stability for heavy and long tubes. The maximum clamping diameter is 25.5 inches and max weight of a single tube is 2,650 pounds.



Technical Details	TL9000-X	TL12000-X
Power	6-12kW	6-12kW
Rotating Speed of Chucks	60r/min	60r/min
Round Tube	0.78-14 in	0.78-14 in
Rectangle	0.78*0.78 - 9.8*9.8 in	0.78*0.78 - 9.8*9.8 in
Single Tube Weight	1322 lbs	2645 lbs
Tube Length	30 ft	40 ft
Dimensions (L*W*H) with Automatic Loading	57*19.5*8 ft	67*19.5*8 ft



Technical Details	TL350-L	TL500-L
Power	6-12kW	6-12kW
Rotating Speed of Chucks	80r/min	30r/min
Round Tube	1.5-12.8 in	4.7-19.7in
Rectangle	1.5*1.5-9*9 in	4.7*4.7mm-13.7*13.7in
Single Tube Weight	1322 lbs	2645 lbs
Tube Length	26/40/50 ft	26/40/50 ft
Dimensions (L*W*H) with Semi-/Full-automatic Loading Device	83.5*21.5*8.8 ft 96.5*21.5*8.8 ft 121*21.5*8.8 ft	83.5*21.5*8.8 ft 96.5*21.5*8.8 ft 121*21.5*8.8 ft



LASER & SYSTEMS

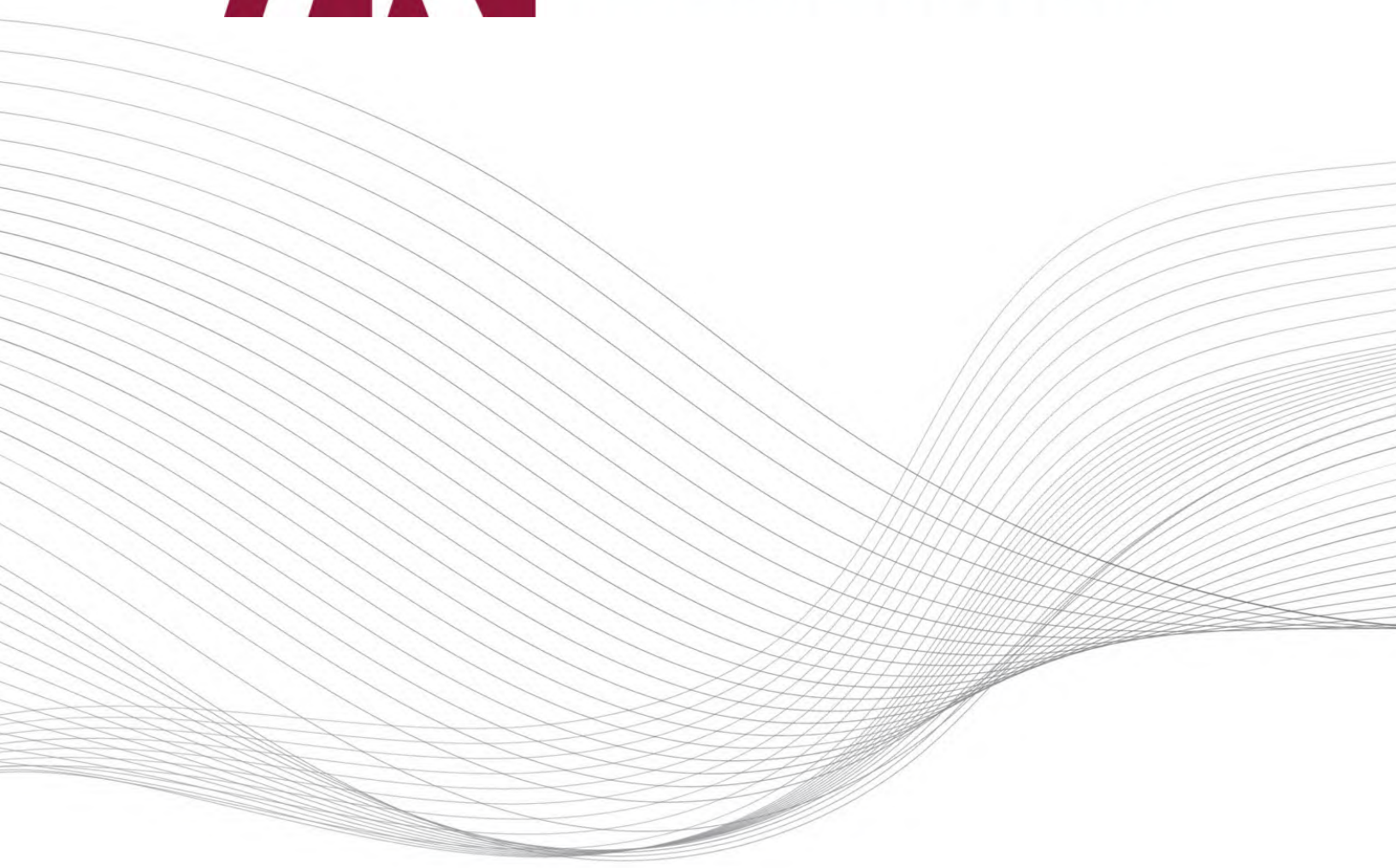

📍 1296 Humbracht Cir.
Bartlett, IL 60103

 AHB TOOLING & MACHINERY	COMPLETE METALWORKING SOLUTIONS
	<small>(800) 991-4225 www.ahbinc.com ISO Certified customerservice@ahbinc.com</small>

hk-us.com