

ITEM	STANDARD FEATURE	BASIC DATA
1	CAPACITY:	SQUARE: 18" X 18" ROUND: 18" DIAMETER
2	BLADE:	1.5" X 19' 2" X 0.050"
3	BLADE SPEED:	50-350 SFM (INFINITELY VARIABLE-VFD)
4	BLADE DRIVE:	10HPX1750RPM(215TC) EL.MTR, PM50 G.BOX , i=45.6/1
5	HYDRAULIC SYSTEM:	HYDRAULIC DRIVE: 3 HP
6	SYSTEM PRESSURE:	1000 P.S.I.
7	TABLE HEIGHT:	31"
8	MAXIMUM WORK LOAD:	10,000 LBS
9	MACHINE WEIGHT:	8,500 LBS ( ESTIMATE)
10	OVERALL DIMS:	88.5"(L)X127"(W)X92.5"(H)
11	BLADE GUIDES:	CARBIDE
12	BLADE WHEEL DIA.	22.0 "
13	HYDR. TANK CAP	9.5 U.S. GALLONS
14	COOLANT TANK CAP.	30 U.S. GALLONS
15	SHUTTLE STROKE:	0-34" SINGLE STROKE MULTI-INDEXING STANDARD
16	WISE CONTROL:	HYDRAULIC (FULL STROKE)
17	CHIP REMOVAL	HYDRAULIC CHIP AUGER
18	OPTIONS:	FULL CAPACITY HYDRAULIC OVERHEAD BUNDLING VARIABLE VISE PRESSURE ROLLER OUTFEED CONVEYOR VERTICAL ROLLERS OUT-OF STOCK LIMIT SWITCH OUTBOARD VISE BUNDLING

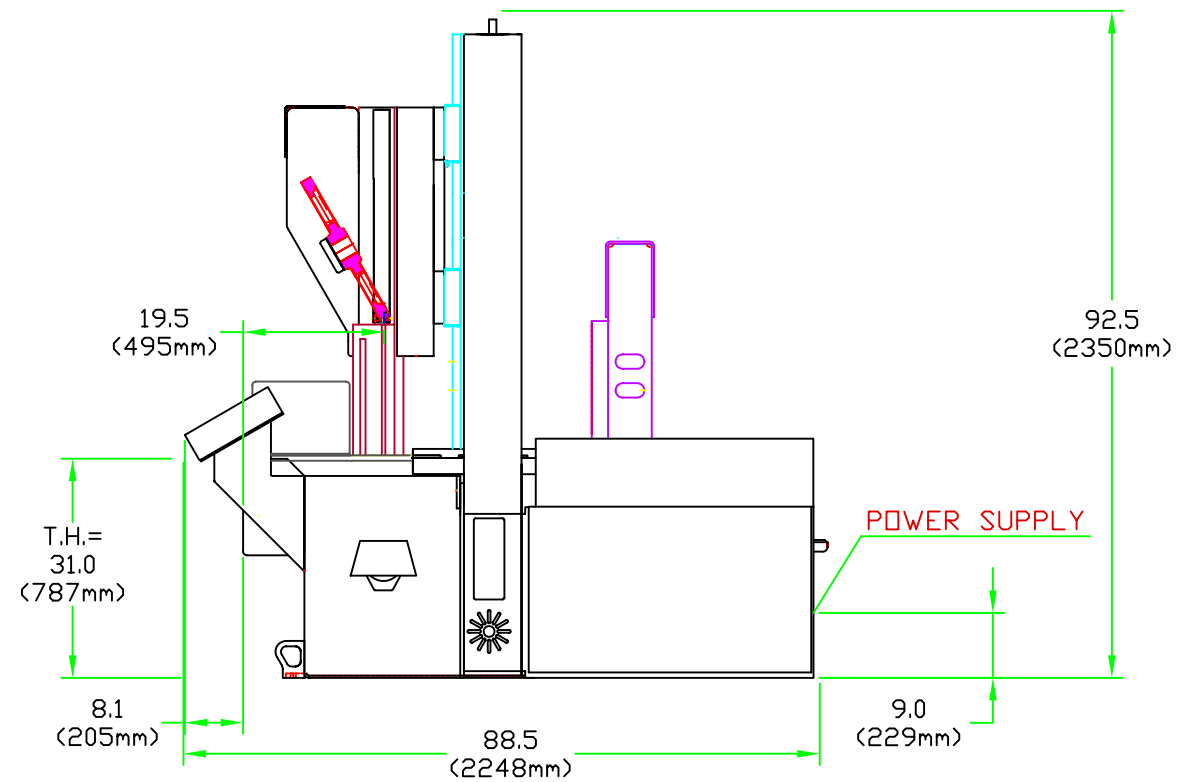
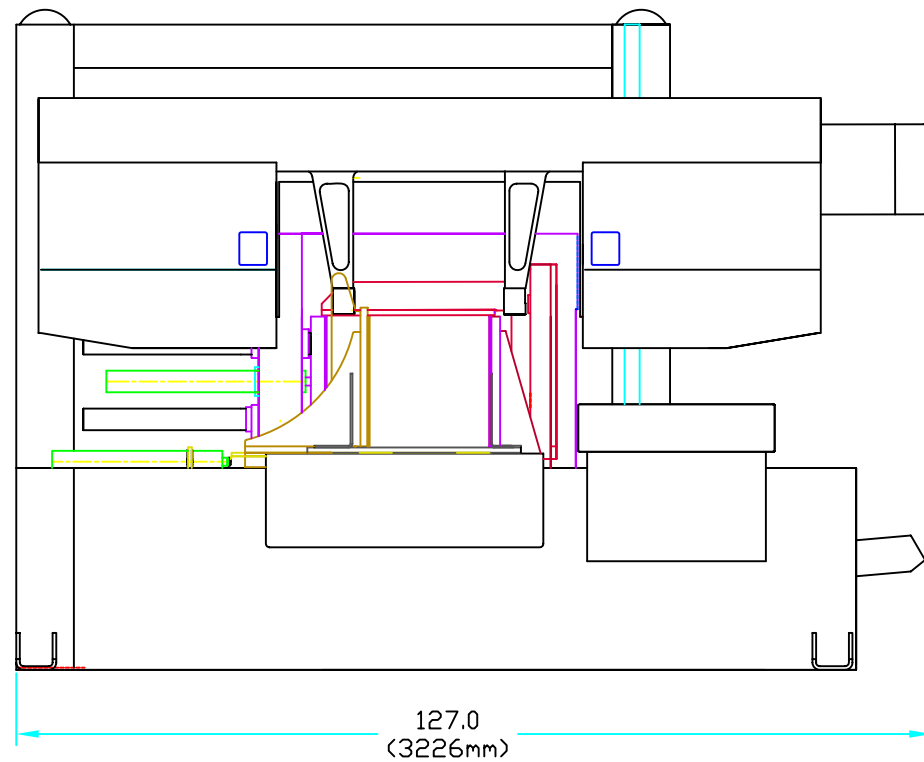

THE DATA/DESIGN CONTAINED HEREIN IS PROPRIETARY AND CONFIDENTIAL. REPRODUCTION, PUBLICATION OR DISTRIBUTION OF ANY PART REQUIRES WRITTEN CONSENT OF HYD-MECH GROUP. THIS DATA IS THE PROPERTY OF HYD-MECH GROUP AND ITS POSSESSION CONFERS NO LICENSE TO USE OR RIGHT OR LICENSE TO DISCLOSE IT TO OTHERS FOR ANY PURPOSE, WHATSOEVER. ALL RIGHTS RESERVED.

REVISIONS				STANDARD TOLERANCES UNLESS OTHERWISE SPECIFIED		HYD-MECH		HYD-MECH GROUP LIMITED				
REV.	ECN NUMBER	DATE	BY	DIMENSIONS ARE IN INCHES		The Real Solid Solution		WOODSTOCK, ONTARIO, CANADA. N4S 8A4				
				LINEAR	ANGULAR	THIRD ANGLE PROJECTION		TITLE: H18SV BAND SAW				
				.X +/- .015 IN	X.X +/- 0.5 DEG			DRWN BY: WR	CHKD BY:	SCALE	SHEET	REV
				.XX +/- .010 IN				DATE: SEP.19.03	DATE:			
				.XXX +/- .005 IN				MATERIAL:				
				√ = 125 MICRONS				DRAWING NUMBER: H18SV-00-00				