



**704-0101-761**  
**Autobend 6**  
**Installation Manual**  
**Revision E**  
**November, 1999**

# **Installation Manual**

## **Autobend 6**

This manual pertains to the Autobend Control System:

(Record Serial Number here)

Hurco Companies, Inc. reserves the right to incorporate any modifications or improvements in machines and machine specifications which it considers necessary, and does not assume any obligation to make any said changes in machines or equipment previously sold.

Hurco products and services are subject to Hurco's then current prices, terms, and conditions, which are subject to change without notice.

---

The information in this document is subject to change without notice and does not represent a commitment on the part of Hurco Companies, Inc. (Hurco). No part of this document may be reproduced or transmitted in any form or by any means, electronic or mechanical, including photocopying, for any purpose without the express written permission of Hurco.

© 1999 Hurco Companies, Inc. All rights reserved. Printed in the United States of America.

Amada is a registered trademark of Amada Co. Ltd.

Hurco and Autobend are registered trademarks of Hurco Companies, Inc.

Guifil is a registered trademark of Guimaraes and Filho, Lba.

IBM and PC/AT are registered trademarks of International Business Machines Corporation.

Komatsu is a registered trademark of Komatsu Ltd.

Many of the designations used by manufacturers and sellers to distinguish their products are claimed as trademarks. Hurco has listed here all trademarks of which it is aware.

**Patents:** U.S. Patents B14,477,754; 5,453,933; Canadian Patent 1,102,434; Japanese Patents 1,649,006 and 1,375,124; other Patents pending.

For more information on Hurco products and services, contact the corporate headquarters in Indianapolis, Indiana or one of the subsidiaries listed below:

**Hurco Companies, Inc.**

One Technology Way  
P.O. Box 68180  
Indianapolis, Indiana  
46268-0180

TEL (317) 293-5309  
FAX (317) 328-2812

Autobend Service

TEL (317) 298-2639  
FAX (317) 328-2806

**Autocon Technologies, Inc.**

38455 Hills Tech Drive  
Farmington Hills, Michigan  
48331-5751

TEL (248) 488-0440  
FAX (248) 488-0430

**Hurco Southeast Asia Pte Ltd**

No. 37 Lorong 23 Geylang  
#0501, Yu Li Industrial Building  
Singapore 1438  
Republic of Singapore

TEL (65) 742 6177  
FAX (65) 745 7664

**Hurco Europe Ltd.**

Lincoln Road  
Cressex Industrial Estates  
High Wycombe  
Buckinghamshire, England  
HP12 3TH

TEL (01494) 442222  
FAX (01494) 444646

**Hurco s.a.r.l.**

Centre Hurco  
Belgique, Espagne, France, Portugal  
Parc d'activité Charles de Gaulle  
4, rue Jean Monnet - BP 702  
95197 Goussainville Cedex France

TEL (1) 39.88.64.00  
FAX (1) 39.92.94.83

**Hurco GmbH**

Benzstrasse 8  
85551 Kirchheim  
Munich, Germany

TEL (089) 9050 9434  
FAX (089) 9050 9450

---

---

Hurco is committed to designing reliable, easy-to-operate machines which promote greater productivity. This system will provide a modern, efficient method of meeting metal forming needs. To prevent serious bodily injury, always observe the safety precautions listed in this manual when installing, operating, and servicing the Autobend System.

These and other safety precautions are discussed in the American National Standards Institute's "Standard for Machine Tools - Power Press Brakes - Safety Requirements for Construction, Care, and Use" (ANSI B11.3). The press brake operator's responsibility regarding his or her own safety, the safety of assigned helpers, and the safety of others affected by the press brake operator's acts is explained in this ANSI publication which is available from:

American National Standards Institute  
1430 Broadway  
New York, NY 10018

In preparing these instructions, we have attempted to recommend the most effective methods and cautions to warn against actions that could cause personal injury or make the equipment unsafe. It is important to understand that Hurco cannot anticipate or list all conceivable methods and warn of all possible hazards. In the interest of promoting safety, Hurco advises that service personnel and operators should always make sure that personal safety, the safety of the operator, and the safe operation of the machine will not be adversely affected by their actions. Review the list of safety precautions before attempting to service or operate the system. Also review the manuals furnished by your press brake manufacturer for additional safety information and procedures that must be observed.

Please read all information for safe, efficient use of the Hurco Autobend 6 Control System.

---

# Using this Manual

---

The *Installation Manual* is intended to be used by customers and Hurco service representatives for installing the Autobend 6 control system. This manual employs several conventions to explain the system concepts and point out key concepts. These conventions are described in this section.

## Sections of the Manual

This manual is divided into these chapters:

Chapter 1 - Introduction

Chapter 2 - Installation

Chapter 3 - Maintenance

Follow the checklist at the end of the “Installation” chapter while installing and referencing the system. Refer to the “Installation” chapter for detailed information.

There is also an index that cross-references the material presented in the manual.

## Style Guide

Indexed terms are *italicized* within the text paragraphs that define them. Titles of books also appear in italic print to meet the English language convention for titles. References to chapter and section names within the text are set in quotation marks for the same reason.

Button names begin with capital letters within the text and in the index to help the reader identify the exact reference as it appears on the system console.

## Standard Text Icons

This manual contains several icons to mark important sections:



### Caution

A “Caution” message tells the operator that the machine may be damaged or a part ruined if the described procedure is not followed.



### Hints

The light bulb icon marks useful suggestions for the press brake operator. These suggestions may show creative uses of the Autobend features or just helpful hints.



### Important

Information marked with this icon must be carefully studied to ensure proper operation of the machine and/or the control.



### Troubleshooting

The toolbox icon indicates steps that can be taken to solve potential problems. These sections contain information for Hurco Technical Service representatives and customers.



### Warning

A “Warning” message indicates that the operator may be injured and the machine tool severely damaged if the described procedure is not followed.



### Where can we go from here?

This icon and heading indicate that at this point in the description the operator has several possible options which are then listed under the heading.

# Table of Contents

---

---

## Chapter 1 - Introduction

Overviews.....	1-1
Installation.....	1-1
Component Mounting .....	1-1
Electrical Connections.....	1-2
System Checklist.....	1-2
Safety Precautions .....	1-3
Control Console Stop Button .....	1-4
Power Cabinet and Console Location .....	1-5
Gauges.....	1-6
Axes' Orientation .....	1-7
Owner's Responsibilities.....	1-8
Machine Modification.....	1-8
Hardware and Software .....	1-9
Installation.....	1-9
Maintenance .....	1-10
Safety Signs.....	1-10
Operators' Responsibilities .....	1-11
Training .....	1-11
Clothing and Other Apparel .....	1-11
Personal Care.....	1-11
System Operation .....	1-12
Part Dimensions and Fixturing.....	1-13
Travel Limits.....	1-13
Part Bending.....	1-14
Subsystem Failure .....	1-15
Electrical Systems .....	1-15
Electrical Safety Guidelines .....	1-16
Procedures for Handling Printed Circuit Boards.....	1-17
Fire Prevention and Fighting.....	1-18
Additional Safety Information.....	1-18
Service Department .....	1-19
Console Keypad Functions.....	1-20
Calibration.....	1-22
Start-up Procedure.....	1-22
Shut-down Procedure .....	1-23



## Chapter 2 - Installation

Preparation for Installation.....	2-1
Parts List.....	2-2
Recommendations .....	2-2
Drill Bits and Tap Sizes .....	2-3
Affixing Safety Decals .....	2-4
Power Cabinet .....	2-5
Control Console .....	2-7
Mounting AB6 Control Console Directly to Press Brake .....	2-8
Mounting Control Console with Optional Pendant Arm .....	2-9
Gauge Installation.....	2-11
Types of Gauges .....	2-11
Gauge Installation Overview .....	2-12
Centerline of Press Brake .....	2-13
Dovetail Slots .....	2-14
Die Retainer Plates .....	2-14
Die Retainer Plates with S6 or S8 Gauges .....	2-15
Die Retainer Plates with S7 Gauges.....	2-15
Gauge Mounting.....	2-16
Number of Gauge Mounting Holes .....	2-16
Gauge Height.....	2-17
S6 Gauge Mounting Hole Dimensions.....	2-18
Hydraulic/Mechanical or Upacting Press Brakes .....	2-18
Komatsu Press Brakes .....	2-19
S7 Gauge Mounting Hole Dimensions.....	2-21
Hydraulic/Mechanical or Upacting Press Brakes .....	2-21
Komatsu Press Brakes .....	2-22
LP11 Gauge Mounting Hole Dimensions .....	2-24
Dual Gauge Mounting Hole Dimensions .....	2-25
S8 Gauges on Hydraulic/Mechanical or Upacting Press Brakes .....	2-25
S8 Gauges on Komatsu Press Brakes.....	2-26
LP21 and LP22 Gauges—Hydraulic/Mechanical or Upacting Press Brakes .....	2-28

Gauge Installation—Gauge Mounting (continued) .....	2-11
X Dimension Tables for Dual Gauges .....	2-29
S8 Gauges on Hydraulic/Mechanical and Upacting Press Brakes .....	2-29
S8 Gauges on Komatsu Press Brakes.....	2-30
LP22, LP22/54 Gauges on Hydraulic/Mechanical and Upacting Press Brakes .....	2-31
LP21Gauges on Hydraulic/Mechanical and Upacting Press Brakes.....	2-31
Mounting Dimensions for Dual Gauges.....	2-32
S8 Gauges on Hydraulic/Mechanical and Upacting Press Brakes .....	2-32
S8 Gauges on Komatsu Press Brakes.....	2-33
LP21, LP22, LP22/54 Gauges— Hydraulic/Mechanical, Upacting Press Brakes .....	2-34
Vertical Mounting for S8 Gauges .....	2-35
Attaching Gauge to Press Brake.....	2-38
Attaching LP21 Rear Cover Kit Assembly .....	2-38
Attaching Adjustable Leg Assembly for LP22/54 Gauges.....	2-41
Gauge Bars and Mounting Devices .....	2-42
Vertical Supports.....	2-42
S6, S7, S8, and Vertical S8 Gauges .....	2-43
LP11, LP21, and LP22 Gauges .....	2-44
Gauge Bars .....	2-45
Y-Shaped Rigid Gauge Bar .....	2-45
Tilting Gauge Bar .....	2-47
LP11, LP21, and LP22 Gauge Bar .....	2-49
Carriage Arrestor Bars.....	2-50
Selecting the Gauging Surface .....	2-53
Flip Fingers .....	2-54
Gauge Blocks .....	2-54
Referencing the Gauging Surface.....	2-55

## Chapter 2 - Installation (continued)

Electrical Connections.....	2-58
Small or Standard Power Cabinets with Main Board .....	2-58
J8 Connector.....	2-59
Advance Connections.....	2-59
Two-Conductor Shielded Cable .....	2-60
Advance Switch.....	2-61
Mechanical Press Brakes.....	2-61
Upacting Press Brakes.....	2-62
Advance Cable .....	2-66
Adira Upacting Press Brakes.....	2-67
Guifil Press Brakes.....	2-69
Advance Relay - Hydraulic Press Brakes.....	2-71
Large Power Cabinet with Relay Board .....	2-76
TB14 Connector .....	2-77
Advance Connections.....	2-77
Two-Conductor Shielded Cable .....	2-78
Advance Switch.....	2-79
Mechanical Press Brakes.....	2-79
Upacting Press Brakes.....	2-80
Advance Cable .....	2-84
Adira Upacting Press Brakes.....	2-85
Guifil Press Brakes.....	2-87
Advance Relay - Hydraulic Press Brakes.....	2-89
Optional Retract Sensor .....	2-93
Retract Sensor Assembly.....	2-95
Magnet Assembly.....	2-95
Installing Magnet Assembly.....	2-96
Small or Standard Power Cabinets.....	2-98
Large Power Cabinet .....	2-99
Advance/Pinch Retract Assembly .....	2-100
AB6 Limit Switch .....	2-100
Installing the Assembly .....	2-101
Connections between System Components.....	2-103
AB6 Control Console Cable.....	2-105
Gauge Cable .....	2-107
Installing Cable to S6 Gauge.....	2-108
Installing Cable to S7 Gauge.....	2-109
Installing Cable to S8 Gauges .....	2-110
Installing Cable to LP Gauges.....	2-111

**Chapter 2 - Installation (continued)**

External Power Source .....2-112  
     Connecting the Incoming Power Line to the Plug.....2-113  
     Connecting the Plug to the AB6 Power Cabinet .....2-113  
     Changing Incoming Power Connections .....2-114  
 Optional Ram Control .....2-116  
 AB6 Installation Checklist .....2-117

**Chapter 3 - Maintenance**

Maintenance Schedule.....3-1  
     Control.....3-1  
     X-Axis .....3-1  
     Y-Axis Downacting Hydraulic.....3-2  
     Y-Axis Positive Stop.....3-2  
     Y-Axis Upacting .....3-2

**Index**



# Figure List

---

Figure 1-1. AB6 Control Console Keypad.....	1-4
Figure 1-2. Side Views of Upacting Press Brake with Small and Large Power Cabinets.....	1-5
Figure 1-3. Front View of Upacting Press Brake with AB6 Control Console Attached.....	1-5
Figure 1-4. Autobend Gauges .....	1-6
Figure 1-5. Typical Axes' Configuration.....	1-7
Figure 1-6. Warning Decal.....	1-10
Figure 1-7. Caution Tape .....	1-10
Figure 1-8. AB6 Control Layout.....	1-20
Figure 2-1. Warning and Danger Decals on Press Brake and Power Cabinet.....	2-4
Figure 2-2. AB6 Power Cabinets Mounted to Clear Area on Sides of Press Brakes .....	2-6
Figure 2-3. AB6 Control Console .....	2-7
Figure 2-4. AB6 Control Console Mounted Directly to an Upacting Press Brake.....	2-8
Figure 2-5. AB6 Control Console Mounted to Press Brake with Pendant Arm.....	2-9
Figure 2-6. Optional AB6 Pendant Arm Bracket and Dimensions .....	2-10
Figure 2-7. Types of Autobend Gauges .....	2-11
Figure 2-8. Centerline of Press Brakes with Single and Dual Gauge Systems.....	2-13
Figure 2-9. Top View of Bed - Upacting Press Brake .....	2-14
Figure 2-10. Top View of S6 or one S8 Mounting on Upacting Press Brake .....	2-15
Figure 2-11. Top View of S7 Mounting on Upacting Press Brake.....	2-15
Figure 2-12. Configuration to Determine Gauge Mounting Height .....	2-17
Figure 2-13. S6 Gauge Mounting Pattern .....	2-18
Figure 2-14. Komatsu S6 Mounting Plate .....	2-19
Figure 2-15. Komatsu S6 Mounting Configuration.....	2-19
Figure 2-16. S7 Mounting Pattern.....	2-21
Figure 2-17. Komatsu S7 Gauge Mounting Plate .....	2-22
Figure 2-18. Komatsu S7 Mounting Configuration .....	2-22
Figure 2-19. LP11 Mounting Pattern .....	2-24
Figure 2-20. S8 Mounting Pattern.....	2-25
Figure 2-21. Komatsu S8 Mounting Plate .....	2-26
Figure 2-22. Komatsu S8 Mounting Configuration.....	2-26
Figure 2-23. LP21 and LP22 Mounting Pattern.....	2-28
Figure 2-24. S8 Mounting Dimensions—Hydraulic/Mechanical and Upacting Press Brake....	2-32
Figure 2-25. S8 Mounting Dimensions—Komatsu Press Brake .....	2-33
Figure 2-26. LP21 and LP22 Mounting Dimensions—Hydraulic/Mechanical and Upacting Press Brake .....	2-34
Figure 2-27. Top View of Vertical S8 Gauge.....	2-35
Figure 2-28. Side View of Typical Press Brake .....	2-36
Figure 2-29. Rear View of Vertical S8 Model Gauge .....	2-37
Figure 2-30. Coupling Hubs.....	2-39
Figure 2-33. S6, S7, and S8 Vertical Support Assembly.....	2-42
Figure 2-34. LP11, LP21, and LP22 Gauge Bar and Vertical Supports .....	2-44
Figure 2-35. Position of Gauge Bar and Vertical Supports .....	2-45

Figure 2-36. Vertical Support and Y-Shaped Rigid Gauge Bar .....	2-46
Figure 2-37. Vertical Support and Tilting Gauge Bar .....	2-47
Figure 2-38. LP11, LP21, and LP22 Gauge Bar and Vertical Supports .....	2-49
Figure 2-39. Carriage Arrestor Bar on S6 or one S8 Gauge .....	2-50
Figure 2-40. Carriage Arrestor Bar on S7 Gauge .....	2-51
Figure 2-41. Side View of Press Brake and Gauge Bar with Carriage Arrestor Bar.....	2-52
Figure 2-42. Flip Fingers and Gauge Block.....	2-53
Figure 2-43. Zero Reference bars .....	2-55
Figure 2-44. Gauge referencing .....	2-57
Figure 2-45. Main Board with J8 Connector .....	2-58
Figure 2-46. Inserting Wires into a J8 Connector.....	2-59
Figure 2-47. Cord Grip.....	2-60
Figure 2-48. Advance Switch Mounting for Mechanical Press Brakes.....	2-61
Figure 2-49. Advance Switch on Upacting Press Brakes .....	2-62
Figure 2-50. Advance Switch with Cover Removed.....	2-64
Figure 2-51. Speed Change Switch on Left Side of Adira Press Brake.....	2-67
Figure 2-52. Guifil Press Brake Wiring Diagram .....	2-69
Figure 2-53. Relay Socket Diagram.....	2-72
Figure 2-54. Relay Diagram.....	2-72
Figure 2-55. Relay Socket Press Connections .....	2-75
Figure 2-56. Relay Board with TB14 Connector - Positions 6 and 7 .....	2-76
Figure 2-57. Inserting Wires into a TB14 Connector .....	2-77
Figure 2-58. Cord Grip.....	2-78
Figure 2-59. Advance Switch Mounting for Mechanical Press Brakes.....	2-79
Figure 2-60. Advance Switch on Upacting Press Brakes .....	2-80
Figure 2-61. Advance Switch with Cover Removed.....	2-82
Figure 2-62. Speed Change Switch on Left Side of Adira Press Brake.....	2-85
Figure 2-63. Guifil Press Brake Wiring Diagram .....	2-87
Figure 2-64. Relay Board with TB14 Connector - K4 Coil A (4) and K4 Coil B (5) .....	2-92
Figure 2-65. Top View of Retract Sensor and Magnet Alignment and Spacing .....	2-94
Figure 2-66. Retract Sensor Assembly .....	2-95
Figure 2-67. Magnet Assembly.....	2-95
Figure 2-68. Main board with J8Connector.....	2-98
Figure 2-69. Relay Board with TB14 Connector - Positions 8 and 9 .....	2-99
Figure 2-70. AB6 Limit Switch .....	2-100
Figure 2-71. Advance/Pinch Retract Switch Assembly.....	2-102
Figure 2-72. AB6 Cable Connections .....	2-104
Figure 2-73. Inside Front of AB6 Control console Showing Cable Connection .....	2-106
Figure 2-74. Inside View of an S6 Gauge.....	2-108
Figure 2-75. Inside View of an S7 Gauge.....	2-109
Figure 2-76. Inside View of an S8 Gauge.....	2-110
Figure 2-77. Inside View of IEC Power Entry Plug and Cover.....	2-112
Figure 2-78. IEC Power Entry Module .....	2-114
Figure 2-79. Side View of Fuse Clip Showing Voltage Selector .....	2-114
Figure 2-80. Top View of Fuse Clip Showing Voltage Selector Window .....	2-115

# Introduction

---

## Overviews

Before installing the gauging system, the installer should become familiar with concepts and terms regarding the Autobend control system. This manual provides procedures for installing the Autobend 6 (AB6) control system. The following are overviews of major concepts and terms used in this manual.

## Installation

Installation of the AB6 involves mounting gauge components to the press brake. The installation requires making electrical connections from the AB6 power cabinet to the gauge and to the console. Connections must also be made from the outside electrical source to the control. Testing the system is the final installation step. A checklist is provided at the end of the “Installation” chapter to use as a guide during installation.

## Component Mounting

The *control console*, *power cabinet*, *gauge*, *gauge bar*, and *supports* are components of the AB6. They are attached to the press brake during the component mounting phase of installation. When the system is installed, make arrangements to have the optional second axis installed by a Hurco factory-trained installer.



## **Electrical Connections**

The AB6 has electrical components that the installer connects within the system, between the system and the press brake, and to outside electrical devices. The advance switch, advance relay, retract sensor, cables (harnesses), and calibration switch are examples of system parts that require electrical connections. The external power source connects to the AB6 power cabinet.

## **System Checklist**

An important step in installing the AB6 is verifying that it is operational. The steps for verifying proper installation of the components and electrical connections are in a checklist at the end of the “Installation” chapter. Follow this checklist while installing the system.

## Safety Precautions

This section is included to address the safety hazards normally encountered with the intended use and the *foreseeable misuse* of the AB6. This product was intended to be used by trained operators who create metal bending programs either on the console or on an off-line system. These operators then run the programs to bend metal. While running the machines, the operators must use their experience and training to make any necessary adjustments and improve the efficiency of their programs.

This safety section describes common problems seen by Hurco Service representatives with suggestions for avoiding or dealing with the problems in a safe manner. However, this information is not an exhaustive description of all of the possible misuses of the machine nor is it a substitute for operator training, skill, and good judgment. Hurco does not accept any liability for *operator error*.

It is important to follow all of Hurco and the press brake manufacturer's safety precautions to avoid personal injury, damage to the machine, and unproductive downtime. Installers must also follow the safety regulations of their shops.

Errors in setup or programming can damage the press brake and cause severe personal injury. The Hurco AB6 does not reduce or eliminate the need for its users to follow the safety and operating instructions the press brake manufacturer provides. Do not ignore safety policies and safeguarding circuits of the press brake's controls.

Be familiar with the following safety issues regarding the press brake and the AB6:

- Control Console Stop Button
- Gauges
- Power Cabinet and Console Location
- Axes' Orientation

## Control Console Stop Button

The AB6 control console keypad and display areas are shown below. Users press the keys on the control console to interact with the system. Press the Stop key on the control any time a jam occurs between the gauging surface and the tooling or if an emergency situation arises involving the AB6 equipment. Refer to the AB6 *Programming and Operations* manual for details about the control console.

Here is the AB6 console:

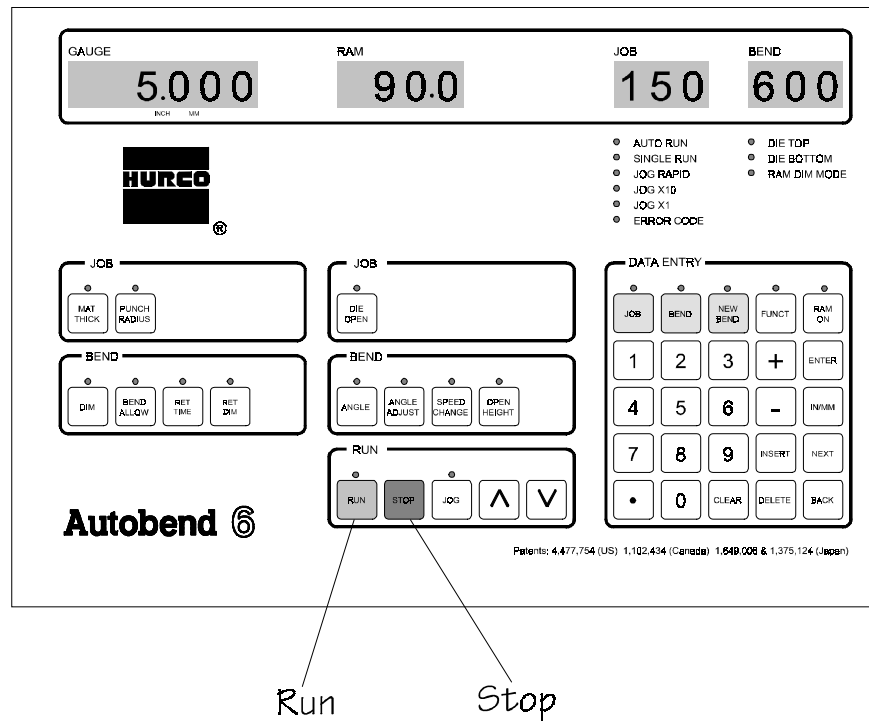

Figure 1-1. AB6 Control Console Keypad



### Important

The Stop button does not force the press brake to stop unless an interlock is wired from the Ram Enable relay (K1) to the press brake logic.

The press brake's Stop or E-Stop does not force either control to stop unless an interlock is wired from the press brake logic to the AB6 relay coil spare relay (K3).

## Power Cabinet and Console Location

Before operating the gauging system on a press brake, become familiar with the machine's components.

The figures below are examples that show *upacting* press brakes with the small and large AB6 power cabinets attached to the side:

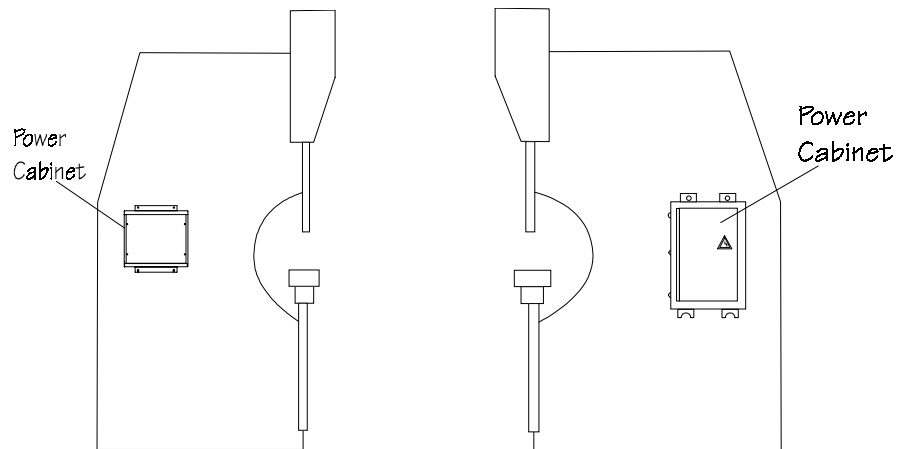

*Figure 1-2. Side Views of Upacting Press Brake with Small and Large Power Cabinets*

The figure below shows an *upacting* press brake with the AB6 control attached directly to the press brake. An alternative method of attaching the control console is to attach it with the optional pendant arm. (Refer to the *Installation* manual for details.)

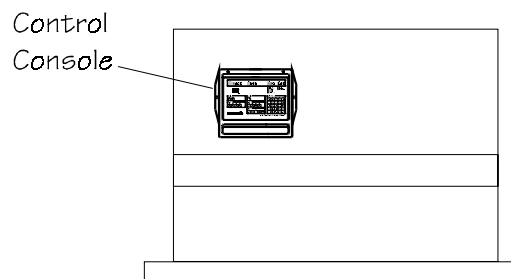
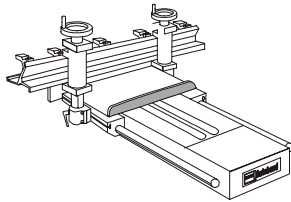

*Figure 1-3. Front View of Upacting Press Brake with AB6 Control Console Attached*

## Gauges

The AB6 operates all S and LP models of Autobend gauges. These gauges are mounted to the rear of different types of press brakes as discussed in the “Installation” chapter of this manual.

The figure below illustrates six models: the S6, S7, S8, LP11, LP21, and LP22. The S6 is narrower than the S7, and the S8 consists of two S6 gauges. The gauge bar length and horizontal adjustment vary among these gauges. The S8 gauge can be mounted horizontally or vertically, while the S6 and S7 can only be mounted horizontally. The LP gauges are longer and narrower than the S gauges.



S6 Gauge Assembly

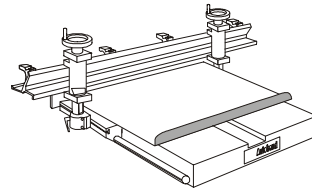

S7 Gauge Assembly

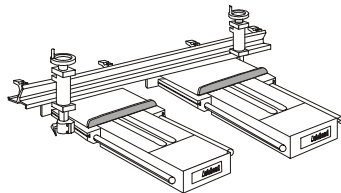

S8 Gauge Assembly

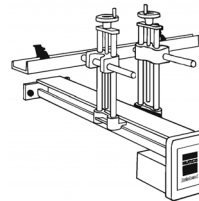

LP11 Gauge Assembly

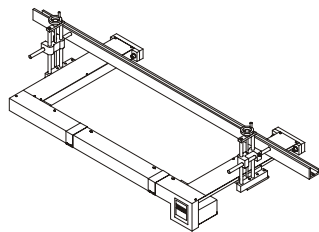

LP21 Gauge Assembly

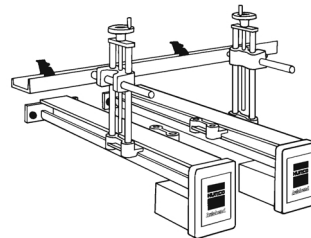

LP22 Gauge Assembly

*Figure 1-4. Autobend Gauges*

## Axes' Orientation

The axes' orientation is best observed from the front of the press brake as shown below. The X-axis positions the gauge bar for the desired flange lengths. The Y-axis controls the stopping point of the press brake's ram for the desired bend to occur. For hydraulic downacting press brakes, the Y-axis can also control the ram's opening height and speed change point.

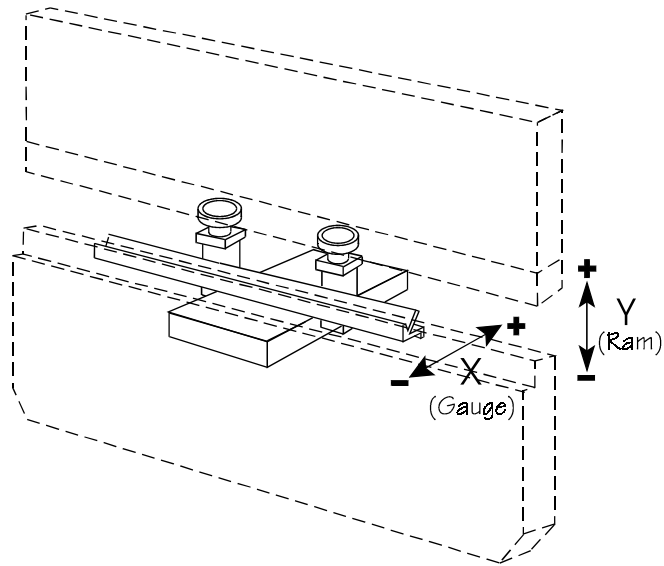

*Figure 1-5. Typical Axes' Configuration*

## **Owner's Responsibilities**

The AB6 owner has several responsibilities regarding safety. First, read this section of the manual and implement the safety requirements described. Then be certain that the operators in the shop are properly trained by Hurco and are using the AB6 as it was intended to be used.

If the Hurco trained operator leaves the shop, the owner is responsible for providing training for the new operator assigned to run the AB6. Call the nearest Hurco facility for information about on-site training or other special training opportunities.

Establish proper procedures to prevent fires and provide approved fire extinguishers to put out small fires. Of course, large fires must be extinguished by professional fire fighters. As a safety precaution, many shops have regular fire drills so that all employees know their responsibilities during an emergency situation.

### **Machine Modification**

The AB6 was designed to meet a wide range of customer needs. If the owner feels that the AB6 needs to be modified in any way to meet the special needs of the shop, Hurco recommends that the owner call Hurco Technical Support or an authorized Hurco distributor for modification assistance and a written authorization to proceed. Contact the press brake manufacturer for information about press brake modification.

If the owner modifies the AB6 in any way without Hurco's assistance and a written authorization, the warranty becomes invalid. In addition, such unauthorized modifications may cause safety hazards that may injure the operator and damage the AB6. The owner is fully responsible for any accidents resulting from unauthorized modifications.

## Hardware and Software

If the owner or an operator modifies the hardware or software by removing, altering, disabling, or tampering with any safety circuit, safety switch, or any safety operation and then continues to operate the AB6 with those modifications, such operation is extremely hazardous, a *foreseeable misuse*, and voids the Hurco warranty. If the owner or an operator finds that such modifications have been made, that person must immediately switch off the AB6 and prevent its use until it has been repaired. The owner must then contact a Hurco service representative for assistance in restoring the AB6 to safe operation.



### Important

In many locales, machine hardware or software modification to override safety protections and continued operation of such a modified machine is illegal and punishable with a fine and/or imprisonment.

## Installation

The owner is responsible for proper site preparation before the AB6 is installed as described in this manual. A Hurco Field Service Engineer or an authorized representative must install the AB6 in the prepared location. This location must not subject the AB6 to uncontrolled cabinet temperatures or unfavorable work environment conditions that could cause electronic component failure.

If the owner decides later to *move the press brake* from its installed location, and if it is necessary to remove the control console from the press brake, Hurco recommends that the owner call Hurco for assistance. Hurco recommends that the owner use a competent rigger with the necessary equipment to move the press brake to the desired location.



## Maintenance

The owner must be certain that the shop's maintenance personnel are trained.



## Warning

This AB6 must not be serviced, repaired, or maintained by unqualified or untrained personnel.

If at any time the operator or owner determines that the electrical cabinet must be opened, the power must be shut off to the AB6 and the press brake before the doors are opened. The only exception to this rule is when the AB6 or press brake is being serviced for electrical problems. Under those circumstances, Hurco Field Service should direct the person performing the work.

## Safety Signs

Safety-related signs are affixed to appropriate AB6 system components. A warning sign appears on the *safety decals* that must be affixed to specific areas on the AB6 components. (See the "Installation" chapter for directions for affixing these decals.) The warning signs alert operators of the possibility of personal injury and damage to the AB6 and press brake if they do not follow the described procedure.

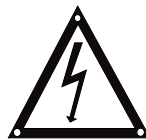

*Figure 1-6. Warning Decal*

The yellow and black caution tape (Hurco Part No. 703-0003-009) is applied across the top rear of the gauge carriage(s) and the gauge bar(s) alerting operators to a hazardous area.



*Figure 1-7. Caution Tape*

## **Operators' Responsibilities**

To avoid serious personal injury, damage to the AB6, and unproductive downtime, pay careful attention to safety precautions and proper maintenance. Press brake operation is often a dangerous task, so operators must stay alert and be aware of potential hazards. Operators must also follow the safety regulations of their shops.

### **Training**

All operators must be trained in order to operate an AB6. The operators who are going to run the press brake must be trained by Hurco or an authorized representative. Before attempting to run the control, study this manual and become familiar with the functions and safety features.

While studying the manual, make special note of the caution and warning messages in the manuals and all warning and instruction plates/decals on the AB6 and the press brake.

### **Clothing and Other Apparel**

Operators should always wear eye protection and safety shoes while in the work area. Safety glasses with side shields are recommended. Do not wear items such as loose-fitting clothing, watches, necklaces, rings, and neckties that could become caught in the moving parts of the AB6 and press brake.

### **Personal Care**

Operators must follow established working practices and personal hygiene standards. As part of this effort, they must avoid frequent or prolonged skin contact with fluids and oils on the sheet metal. Some operators wear gloves or use a special hand cream to protect their hands from these chemicals. If operators get chemicals on their hands, they must wash their hands immediately upon leaving the AB6 and pressbrake and before taking a break. They must also change clothing that has become contaminated with fluids and oils.

For complete information about handling industrial chemicals used in machining, refer to the international Control of Substances Hazardous to Health (COSHH) materials from the chemical suppliers.

## System Operation

When operating an AB6, always follow these safety rules:



### Warning

- Review all safety information and operating instructions the press brake manufacturer provides before attempting any operation.
- Use the press brake's Emergency Stop circuits to control emergency situations involving the AB6 and the press brake.
- Use the AB6's Stop button to control emergency situations involving the AB6 and the press brake.
- Turn the operator control(s) to Off before attempting to adjust the system.
- Use proper point of operation safeguarding.
- Adjust the gauging system from the rear of the press brake.
- Keep hands out of the point of operation and clear of the press brake's forming tools.
- Never reach across the press brake tooling to make any adjustment.
- Never attempt to make any adjustment to the system by reaching through the press brake's point of operation.
- Check the installation of the carriage arrestor bars before operating the system.
- Be sure that the gauge bar and flip fingers are correctly referenced to the press brake's tooling before attempting operation.
- When testing the AB6, check the ram adjustment before stroking the press brake. Set the down limit switch as required per the press brake's manufacturer. Tooling must not bottom out before the ram reaches the low end of its stroke.

## System Operation (continued)

- When testing and running the AB6, never attempt to bend metal that requires tonnage beyond the capacity of the press brake or the tooling, whichever is less.
- Never operate a disassembled system.
- Disconnect the external power source before attempting to connect or make adjustments within the power supply box or the AB6 power supply cabinet. Only qualified personnel should service this equipment.
- Before operating the system be sure that installers or operators will not be struck by the rapid movement of the gauge bar. Also make certain that nothing interferes with the gauge movement in either direction.

### Note

This list does not include all of the possible hazards regarding the AB6 and the press brake.

## Part Dimensions and Fixturing

Never bend a part on the gauging system that is larger than the working surface of the press brake or that juts out on any side beyond the edges of the press brake. If a part requires a range that is greater than the guarding allows, the work must be performed on another system having the necessary work volume capability.

Operators must follow procedures for referencing the bending material before starting the AB6. Remember that loose objects, such as wrenches and chuck keys, can become flying projectiles if not removed from the gauge bar before the AB6 is started. Be aware of protruding machine members (such as hoses, piping, or ductwork) when working around the AB6 and the press brake.

## Travel Limits

Safety *limit switches* provided for each system must not be removed or bypassed in order to obtain more travel or take short cuts. Serious damage to the AB6 and personal injury to the operator may result from such actions. It is also dangerous to bend a part that requires operation outside the limits of the AB6. A larger press brake should be used for such a part.

## Part Bending

Always know the locations of the *Stop* key on the press brake and AB6 control. The operator must be very careful when working in the area of the gauge. To prevent injury, the gauge should be completely stopped before the operator attempts to make adjustments to a work piece or the gauging surface.



### Warning

When running programs, always follow these rules:

- Never press the *Run* key without knowing exactly what the AB6 and pressbrake will do!
- Never start the AB6 when the back gauge is in contact with the work piece.
- Never stand in the rear inside area between the back of the press brake bed and the gauge bar while the gauge is moving.
- **Never leave the AB6 or the press brake unattended.**

Always work within reach of the Stop keys and observe the operation of the gauge. Running a program out of reach of the Stop key and not observing the gauge is considered *unattended operation* and is viewed as a *foreseeable misuse* of the AB6.

## Subsystem Failure

Maintenance personnel and trained operators need to understand the maintenance requirements and possible problems associated with the press brake subsystems. They can become familiar with the subsystem maintenance requirements by studying the press brake's maintenance manual.

### Electrical Systems

Clean electrical AC power source, as defined in the ANSI/NFPA 79 standard, is essential to the successful operation and continued reliability of the AB6. Therefore, the gauging system must be properly connected to its power source as described in detail in this manual. The system must be attached to a dedicated, fused, and isolated line with incoming power that matches the specified, factory-wired, power cabinet voltages, and current requirements of the AB6 system.



### Warning

If the AB6 is not properly connected to its power source, there may be electrical noise and fluctuations with the power source that will affect safety, performance, and the warranty. In addition, brown-out conditions and surges may occur in the shop, and the AB6 electrical components may fail and require replacement.

## Electrical Safety Guidelines

Follow these electrical safety guidelines before operating the AB6:

1. Provide a clean source of electrical power with a separate dedicated incoming power line (hot, neutral, and ground wire).
2. Ensure that this source of electrical power is of proper voltage and is free of electrical sags, surges, spikes, and noise. This source must be free of inductive loads that might cause high-frequency electrical noise.
3. Prevent an unwanted ground loop. The electrical control systems are interconnected to terminate at the central point ground terminal located inside the AB6 power cabinet. This single point ground must be connected to the ground circuit of the electrical power source so that it provides only one conducting path (between the AB6 power cabinet and the power cord).
4. Route all AB6 cables to prevent close contact (6" - 10", 150 mm. - 250 mm.) with any press brake control, voltage line, motor, or other noise-generating devices.
5. Attach all system cables properly to the press brake's frame. Loop cables with excessive length. Use the extra large tie wraps and 3/8" self-tapping screws provided to attach the cables to the frame.

## Procedures for Handling Printed Circuit Boards

Static charges are present at all times and in all environments. Damage to sensitive electronics occurs at lower voltage levels than people can sense. Static damage may cause total failure or degrade the circuits' performance and can eventually lead to intermittent or total failure. Prevent component damage by discharging static electricity to a ground. Follow the procedures below.

Before touching, adjusting, or removing a printed circuit board (PCB), wear a wrist strap grounded to the cabinet or enclosure ground point. If a grounding wrist strap is not available, touch a grounded point within the enclosure each time before touching a PCB or electronic assembly. An example of a *grounding point* is the metal cabinet's screws.



### Caution

Limit the direct handling of the PCB to reduce the chance of damage.

Keep the PCB in a protective bag until it is installed. Use static handling procedures before opening the bag and removing the circuit board. Return all replaced PCBs to the static protective bag.



## Fire Prevention and Fighting

There are some obvious causes of fires that should be avoided in all shops:

- Storing or handling flammable materials near heat sources
- Not keeping the work area clear of debris such as shop clothes, cartons, and other shop supplies that could catch fire

If a fire does occur, press the Stop key on the control and on the press brake and activate the factory's fire alarm system to evacuate personnel who are not directly involved with extinguishing a small fire. Shop personnel may be able to put out small fires using extinguishers approved for the conditions in their shops. However, if it is clear the fire is uncontrolled or too large for the shop extinguishers, professional fire fighters must be called and all shop personnel evacuated.

If a fire has occurred and the shop personnel have extinguished it, it may still be wise to contact the fire department or fire prevention authorities for advice to be certain the fire has been completely extinguished and to help prevent future fires. Fire extinguishers should be tested for proper operation at least three times a year by a trained and certified inspector.

## Additional Safety Information

For additional safety information Hurco recommends the following sources:

1. National Safety Council  
444 N. Michigan Avenue  
Chicago, Illinois 60611
2. State, provincial, and local safety codes
3. Worker's compensation carrier's loss prevention department
4. Press brake manufacturer

## Service Department

The goal of Hurco's Autobend Service Department is to provide customers with services necessary to help ensure success in their investment. If customers experience problems with the AB6 components such as screen errors, lack of power to the components, or gauge performance that are not solved by suggestions in the "Error Codes" section of the *Programming and Operations* manual, they should contact Hurco's Service Department by calling the appropriate phone number listed in the first section of this manual. The Service Department personnel will attempt to correct problems in an efficient and timely manner, saving the company downtime.

The AB6 serial number is located on the door of the AB6 power cabinet's data plate. Record the serial number here and on the cover page for reference:

Please provide the following information when calling Hurco's Service Department:

1. company name and telephone number
2. name and extension
3. serial number
4. a brief, accurate description of the problem and its specific symptom(s)

The Hurco Autobend Service Department is committed to helping customers obtain the maximum benefits from investing in its products.

Call (317) 298-2639 for Hurco's Autobend Service Department in Indianapolis.

## Console Keypad Functions

Below are descriptions of the AB6 console keypad functions. Be familiar with these functions before testing the system.

The AB6 control contains a display group at the top of the control where programming entries or default values appear. There are also programming keys with dedicated LEDs (light emitting diodes).

Values for Gauge, Ram, Job and Bend appear in the displays. Single axis Job and Bend programming keys are below the Gauge display, and dual axis Job and Bend programming keys are below the Ram display.

The Data Entry keys are grouped together. Use them to select tasks, scan job and bend lists, perform calculations, select special functions, and input numbers. Within this group of keys are the yellow Job, Bend, and New Bend programming keys.

The keys in the Run group are the operation keys. Use them to select Auto or Single Run mode and to jog the selected axis.

Here is the AB6 control layout:

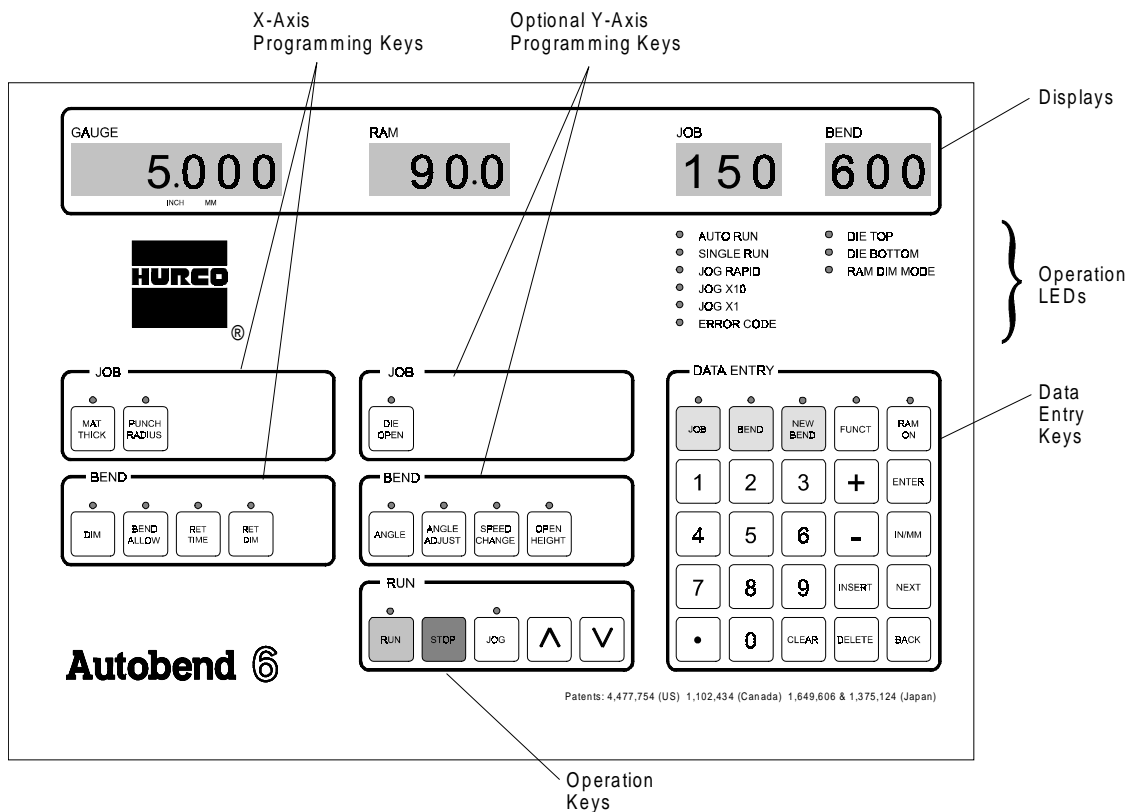

Figure 1-8. AB6 Control Layout

The Programming keys are grouped with the Data Entry keys. Programming, Job, Bend, and Run keys have dedicated LEDs to show whether their state is Active (On) or Stand-by (Off). Use the Programming and Data Entry keys to perform these functions:

**Programming Key      Function**

Job	Activate the Job display and input new jobs.
Bend	Activate the Bend display and input bend number.
New Bend	Activate the Bend display and input a new bend number.
Funct	Used in conjunction with other programming and data entry keys to enable special functions.
Ram On	Select ram control status (On/Off).

**Data Entry Key      Function**

Enter	Enter selected data, move cursor the next prompt, transfer Die Top and Die Bottom positions, and transfer the Teach position.
IN/MM	Select measurement unit (inch or metric). This key is used with the Funct key.
Next	Select the next job parameter or bend parameter, depending on mode.
Back	Select the previous job parameter or bend parameter, depending on mode.
Insert	Insert a new bend.
Delete	Delete the displayed job or bend.
+	Input positive data entries or perform Calculator functions.
-	Input negative data entries or perform Calculator functions.
Clear	Clear displayed data.
0-9	Use the number keys to input numerical values, or to perform special functions when used in conjunction with the Funct key.



**Important**

Refer to the *Programming and Operations* manual for more information about calibration and job programming.

## Calibration

The axes automatically calibrate and position to the first bend (i.e., station) during start-up when a job is programmed and the Run button is pressed. There are additional calibration procedures to follow for the AB6 control. Refer to the *Programming and Operations* manual for details.

## Start-up Procedure

The following sections contain procedures for powering up the AB6 control.

Follow these instructions to power up the AB6 system:

1. Turn on the power to the AB6 using the switch on the side of the AB6 power cabinet. The AB6 control performs this power-up sequence:
  - a. All segments of the LEDs light up for approximately 3 seconds.
  - b. The software version number appears in the Gauge display.
  - c. The date appears in the Ram display.
  - d. The number of available Jobs and Bends appears in their displays.
2. Turn on the power to the press brake and start the pump motor by following the manufacturer's instructions.
3. Following the power-up sequence, data for the most recently operated job appears in the Job and Bend displays. Program the job if it is not already programmed. (Refer to the "Programming and Operations" chapter of the AB6 *Programming and Operations* manual for more information.)
4. Press the Job key.
5. Select a job from memory by inputting a Job number, or program a new job.
6. The axes calibrate and then position to the first bend.
7. The bending operation may begin.

## Shut-down Procedure

This section describes procedures for shutting down the AB6 control:

To shut-down the AB6, follow these steps:

1. Press Stop. This disables the servos and turns off the Run key's LED.
2. Block the press brake's ram and turn off the power to the press brake by following the manufacturer's instructions.



# Installation

---

This chapter contains directions for installing the Autobend 6 (AB6) control system. Familiarity with this information before beginning the process provides better results.



### Warning

Do not connect electrical cables until completing the procedures in the “Electrical Connections” section.

## Preparation for Installation

Prepare for the installation by following these steps and gathering the proper tools:

1. Read the “Introduction” chapter of this manual before attempting to install the system onto the press brake.
2. Lay out the gauging system parts on a clean work area near the press brake.
3. These tools are required for installing this gauging system:
  - Ohmmeter
  - Assorted screwdrivers and wrenches
  - Allen head wrench set (Metric and U.S. Standard)
  - Electric drill (magnetic base drill recommended)
  - Assorted drill bits
  - Plumb and level
  - Center punch and scribe
  - Tap handle, assorted taps, and tapping fluid



## Parts List

The AB6 is foam packaged for protection during shipment. Remove the parts from the foam packing and inventory them by using the *Parts Lists* included with the system.

## Recommendations

These instructions represent typical installations and may not have the same physical appearance as a particular press brake. However, the instructions apply unless otherwise stated.



### Important

If the press brake or its physical location requires *mounting variations* not illustrated, remember the following important recommendations:

- Make certain that the mounting of a component or assembly does not interfere with the operation of the press brake.
- Mount the gauge frame to the press brake, and make sure the gauge bar can reach the forming tools.
- Attach the control console and the AB6 power cabinet on the same side of the press brake. If this arrangement is not possible, check the control console cable length to be sure it will reach the power cabinet.
- If it is not possible to mount the AB6 power cabinet directly to the press brake, use a bonding conductor between the press brake and the AB6 power cabinet.



### Caution

To avoid personal injury be certain to follow safe shop practices. Be familiar with technical work and press brake operation.

## Drill Bits and Tap Sizes

Use these drill bits and tap sizes for installing this gauging system:

U.S. Standard Hardware	
Inches	
3/4 - 10 tap (S7 Gauge)	21/32 bit
5/8 - 11 tap (S6 Gauge)	17/32 bit
1/4 - 20 tap	13/64 bit
10-24 tap	#24 bit
1/4 - 20 × 1/2 self-tapping screw (AB6 small Power Cabinet)	7/32 bit
5/16-18 tap (AB6 large Power Cabinet)	Size F bit

Metric Hardware	
Millimeters	
M20 × 2.5 P tap	17.50 bit
M16 × 2.0 P tap	14.0 bit
M8 × 1.25 P tap	6.80 bit
M6 × 1.0 P tap	5.0 bit

## Affixing Safety Decals

At the beginning of the installation process it is important to affix Hurco's safety-related decals to the press brake in the locations shown below.

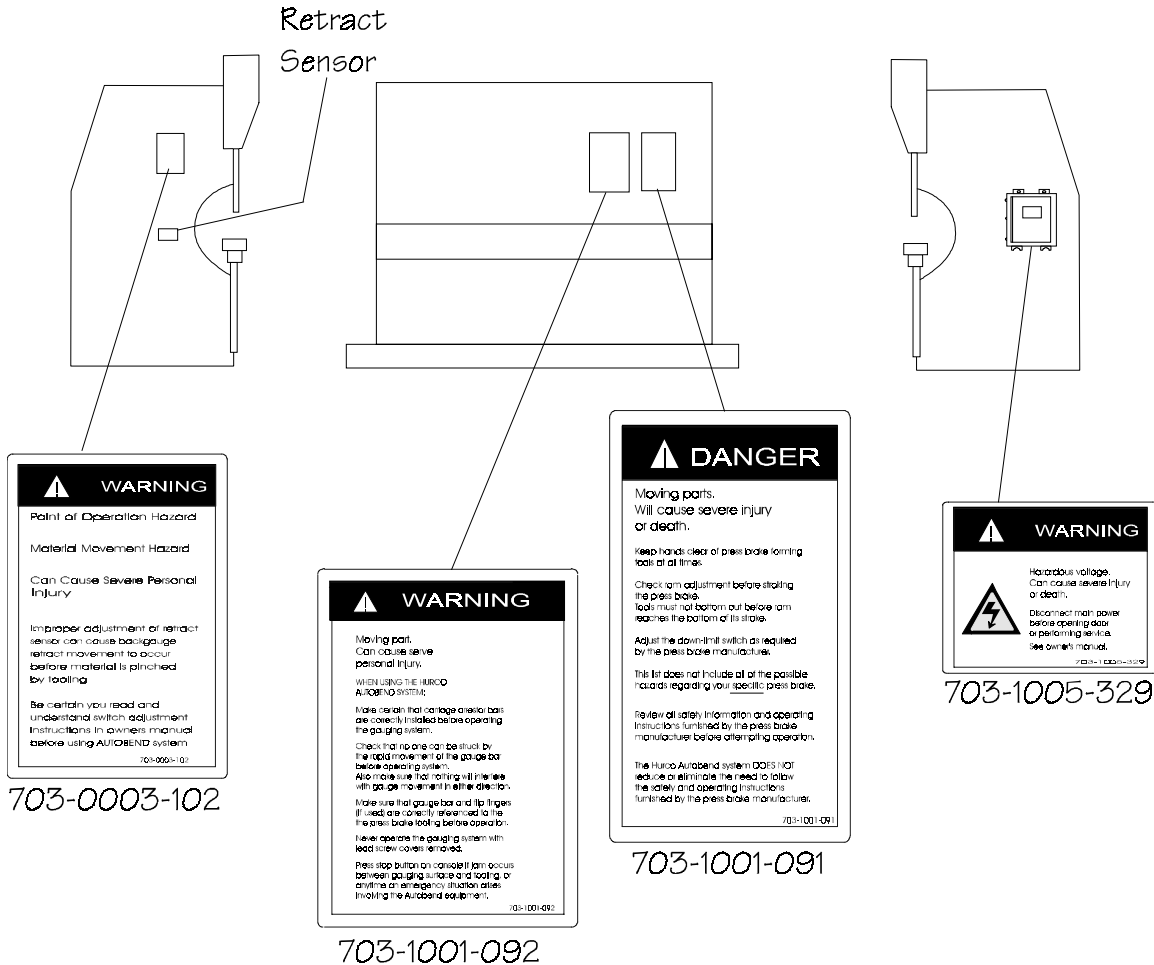

**Figure 2-1. Warning and Danger Decals on Press Brake and Power Cabinet**

### Note

Customers may order replacement decals at no charge by contacting Hurco. Please have the AB6 serial number available when placing an order.

---

## Power Cabinet

The AB6 power cabinet houses the electrical circuits that transfer energy from the outside power source to the control console. Attach the AB6 power cabinet on the same side that the press brake's control box is attached if possible.

There is a *warning decal* on the AB6 power cabinet's door that cautions the operator to disconnect main power before opening it. The decal also warns about the possibility of personal injury. When it is necessary to access the electrical circuits inside the AB6 power cabinet, remove the cabinet's door.



### Caution

Consider *cable runs* when selecting the area to mount the AB6 power cabinet. Never install cables so they interfere with the press brake's throat. It is important to allow clearance for incoming power and second axis components (for example, linear scale assemblies and Y-axis motor drive units).

Follow these instructions to mount the AB6 power cabinet onto the press brake:

1. If possible, position the power cabinet on the same side as the press brake's control box.
2. Mount the power cabinet in a clear area on the press brake. Do not mount it in the shaded areas as shown in the figures on the following pages.
3. Use the power cabinet as a template to locate and mark the centerline of its four (4) mounting holes. Allow at least 6" (150 mm) of clearance between the bottom of the power cabinet and the floor for plugging in the cables.
4. Drill the four (4) mounting holes, using the drill bit and tap sizes indicated in the drawing on the following page.
5. Clean the surface of the press brake and bolt the power cabinet in position.

The figure below illustrates correct AB6 power cabinet mounting to a clear area on the side of press brakes.



**Important**

The power cabinet can be mounted to either side of the press brake provided the cable length requirements are met.

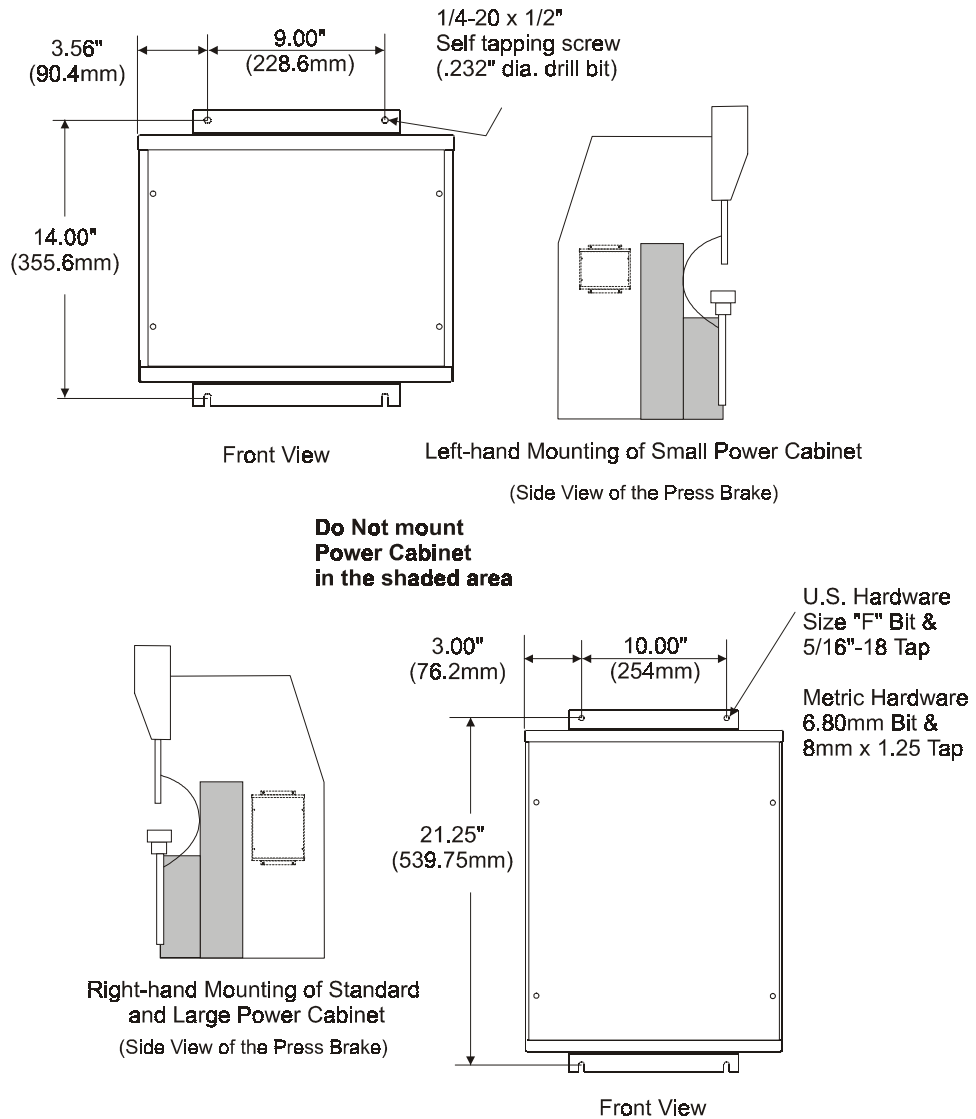

*Figure 2-2. AB6 Power Cabinets Mounted to Clear Area on Sides of Press Brakes*

## Control Console

The front of the AB6 LED control console contains displays, data entry keys, and operation keys. Use the Stop key during an emergency situation involving the AB6 equipment. For information about the key functions and running jobs, see the *Programming and Operations* manual.

There are two methods of mounting the AB6 control console to a press brake: directly, or with the optional pendant arm. The sections that follow describe these methods. This is the AB6 control console:

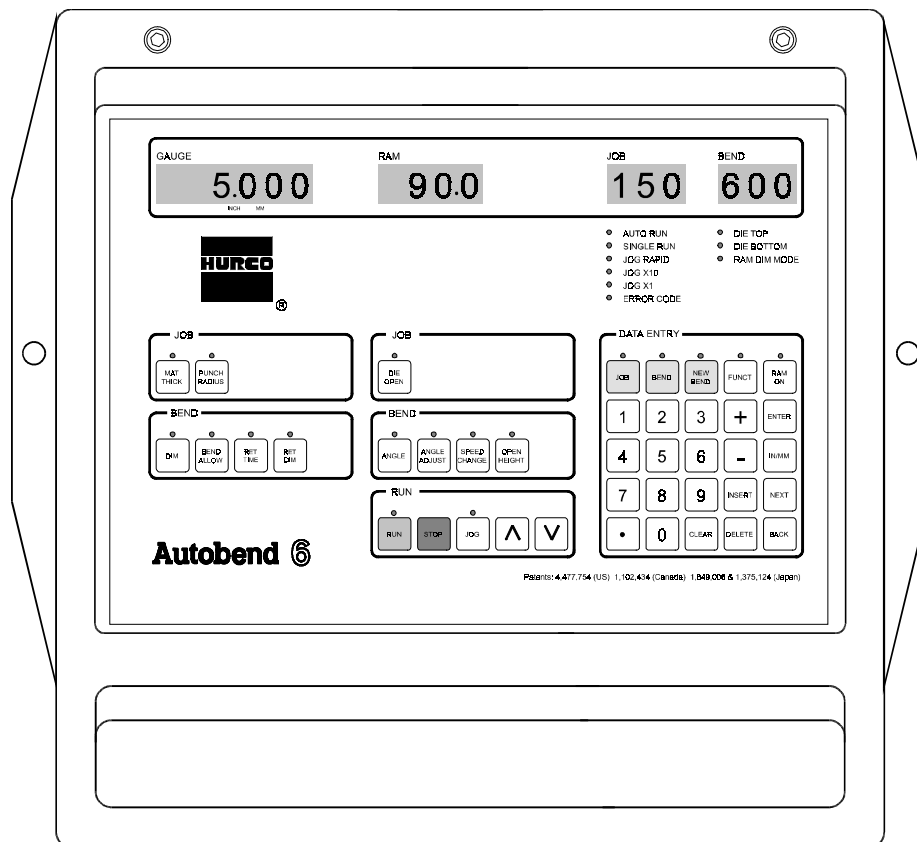
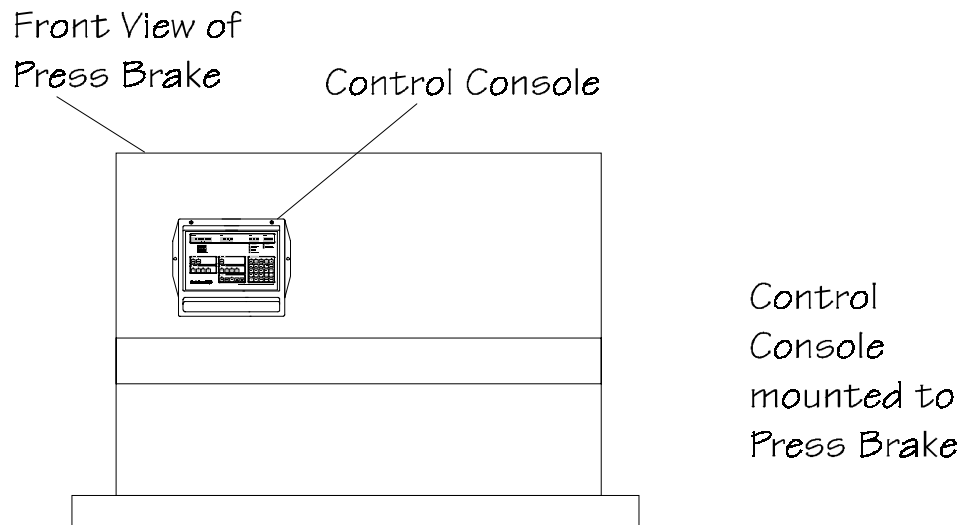

Figure 2-3. AB6 Control Console

## Mounting AB6 Control Console Directly to Press Brake

To install the AB6 control console directly to the press brake, follow these instructions:

1. Mount the control console in a clear area on the front of the press brake.
2. Use the control console as a template to locate and mark the centerline of its two (2) mounting holes.
3. Drill the two (2) mounting holes, using the 5/16" (M8) bolt drill bit and tap sizes.
4. Clean the surface and bolt the control console in position.



*Figure 2-4. AB6 Control Console Mounted Directly to an Upacting Press Brake*



### Caution

Do not mount the control console on a moving part of the press brake or where it could cause interference. The placement of the control console depends on the type of press brake.

## Mounting Control Console with Optional Pendant Arm

To install the optional pendant arm to the press brake, follow these instructions:



### Caution

Make sure to position the pendant arm and the control console so they do not interfere with the press brake's operation.

1. Determine the position of the pendant arm so the control console is at the operator's eye level. The pendant arm projects approximately 40" (1016 mm) outward from the press brake.
2. Determine the correct position of the pendant arm bracket. Locate and mark the centerline of its four (4) mounting holes on the press brake's surface. Be sure that the top of the bracket is level and square against this surface.
3. Drill and tap the holes for the bracket in the press brake.
4. Use the four (4) 5/16-18 x 3/4 LG (M8 x 20 LG) SHCS to attach the pendant arm bracket to the press brake.
5. Attach the control console's pendant arm bracket with the four (4) M8 x 1.25 P x 16 LG SHCS to rear of the control console.

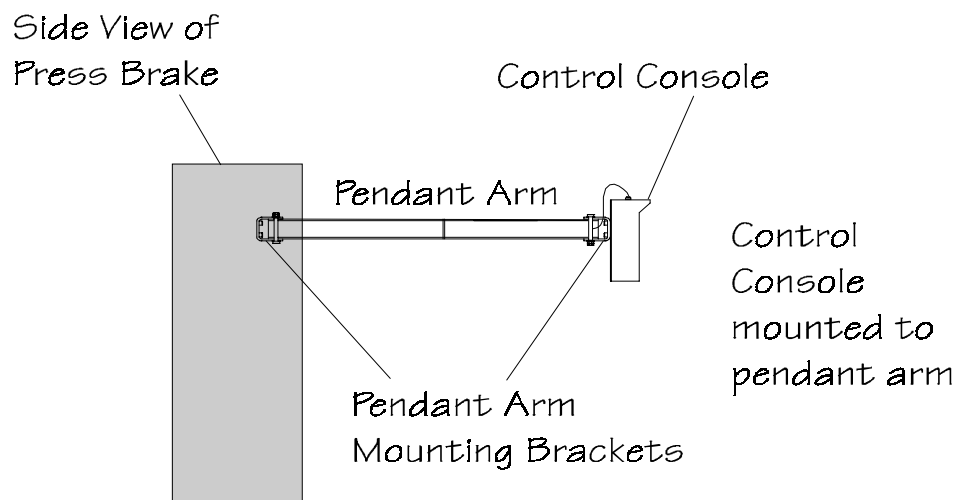

*Figure 2-5. AB6 Control Console Mounted to Press Brake with Pendant Arm*



The figure below shows the pendant arm's mounting plate dimensions:

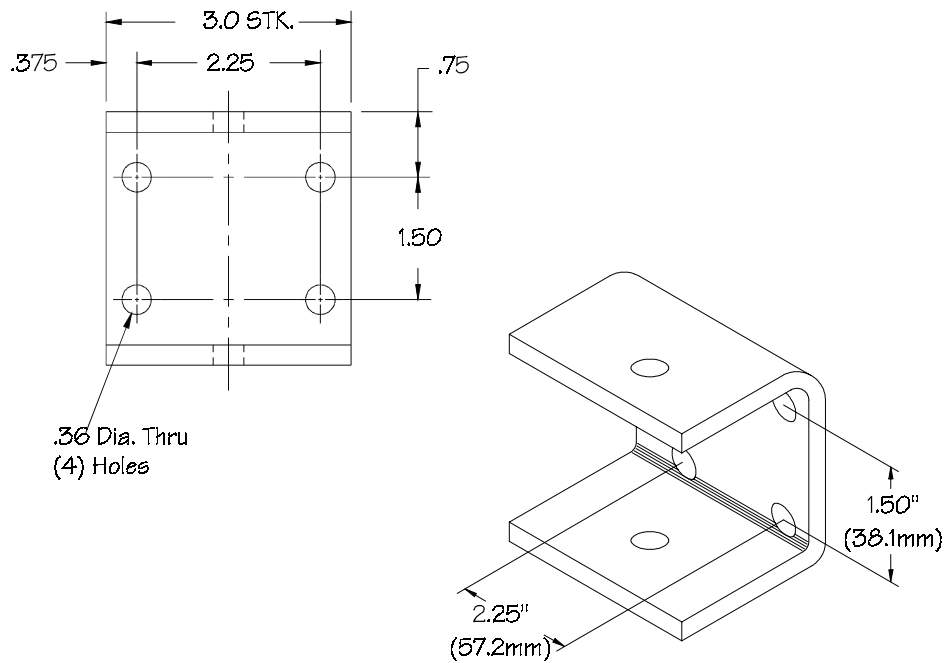

*Figure 2-6. Optional AB6 Pendant Arm Bracket and Dimensions*



### Important

If using the optional pendant arm, install it onto the press brake then mount the console to the arm.

## Gauge Installation

Because of the different types of Autobend gauges and types of press brakes, this section is organized according to the installation steps. Detailed instructions for mounting single and dual gauge systems follow. Be sure to pay close attention to the subheadings that identify choices for the process. The “Where can we go from here?” messages identify the ending of a particular section and lead to the appropriate section.

### Types of Gauges

The AB6 control console operates all models of Autobend gauges. These gauges are mounted to the rear of different types of press brakes. The figure below illustrates the S6, S7, S8, LP11, LP21, and LP22 gauges. This section also contains installation procedures for the LP22-54 and vertical S8 gauges.

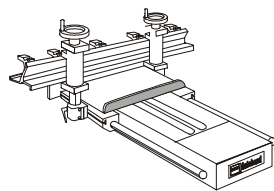

S6 Gauge Assembly

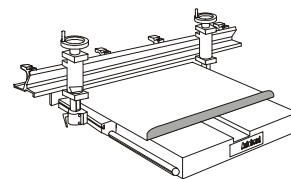

S7 Gauge Assembly

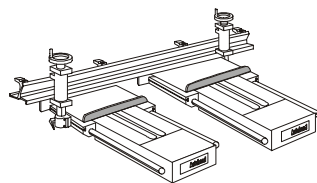

S8 Gauge Assembly

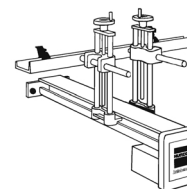

LP11 Gauge Assembly

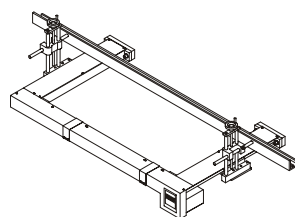

LP21 Gauge Assembly

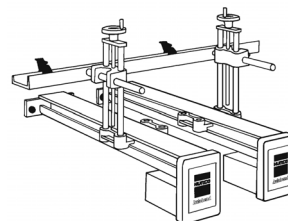

LP22 Gauge Assembly

*Figure 2-7. Types of Autobend Gauges*

## Gauge Installation Overview

Here are the basic steps to the gauge installation process:

1. Locate and mark the rear centerline of the press brake.
2. Determine the gauge height.
3. If drilling and tapping are necessary to mount the gauge(s), determine the bolt hole locations and mark their centerlines.
  - a. Use a plumb and level to ensure the holes are parallel to the top of the press brake.
  - b. Drill and tap the holes.
  - c. If the mounting surface is irregular or not machined, use shims between the press and the gauge(s).
  - d. Thoroughly clean the mounting surface before attaching the gauge.
4. Attach the gauge to the press brake and install the mounting bolts and washers. Make sure the gauge is level front to back. Tighten the bolts securely against the washers.
5. Wipe down the lead screw and carriage ways with a soft, lint-free cloth. Apply a light film of S.A.E. #10 machine oil to the lead screw and both rod ways.
6. Mount the gauge bar as described in the “Gauge Bar and Mounting Devices” section of this manual.
7. Consult the “Maintenance” chapter for *maintenance procedures*.



### Where can we go from here?

Begin with the “Centerline of Press Brake” section of this chapter.

## Centerline of Press Brake

Locate and mark the rear centerline of the press brake between the inside of the housings at the rear of the press.

- The gauge attaches to the bed on a downacting press brake.
- The gauge attaches to the ram on an upacting press brake.

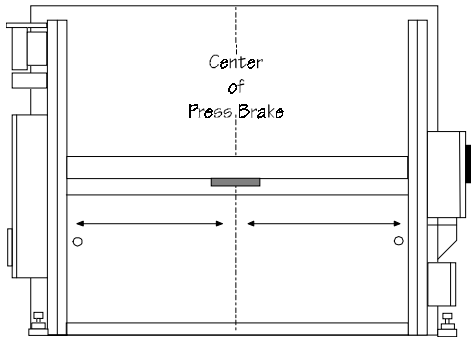

Single Gauge System

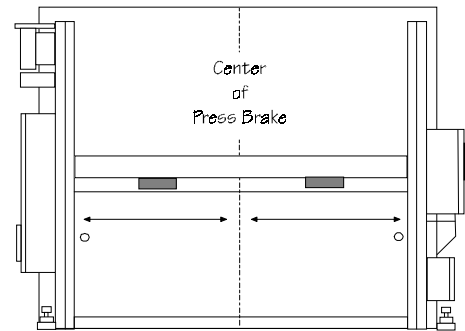

Dual Gauge System

*Figure 2-8. Centerline of Press Brakes with Single and Dual Gauge Systems*



### Where can we go from here?

Depending on the press brake's configuration, refer to either the "Dovetail Slots," "Die Retainer Plates," or "Gauge Mounting" section in this chapter before mounting the gauge to the press brake.

## Dovetail Slots

For press brakes with *dovetail slots* in the rear of the bed, mounting can be accomplished easily without drilling. Use the dovetail bolts, flat washers, and nuts in the installation kit.

## Die Retainer Plates

Follow these steps for press brakes that use die retainer plates:

1. Remove the die retainer plates where the gauge will mount.  
(See the figure below.)

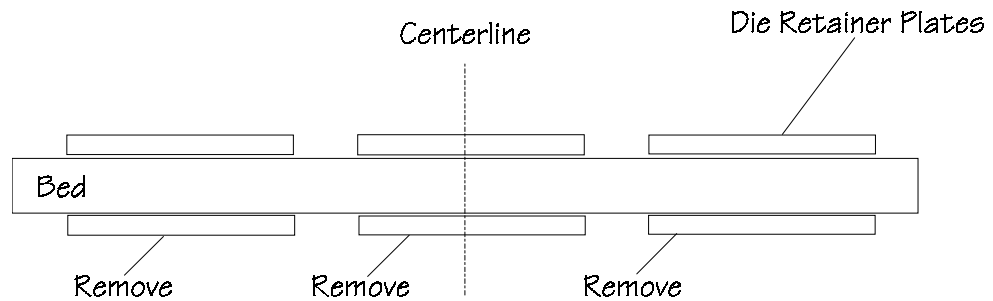
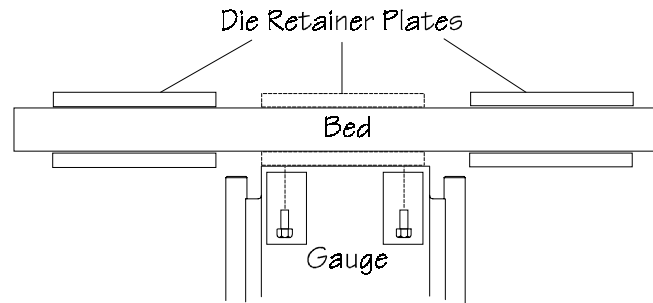

*Figure 2-9. Top View of Bed - Upacting Press Brake*

2. Install the support pins into the front surface of the gauge's mounting plate as shown in the figures on the following page.
3. If the mounting surface is irregular or not machined, use shims between the press and the gauge's mounting plate.
4. Place the die retainer plates over the bolts and support pins.

## Die Retainer Plates with S6 or S8 Gauges

This figure represents an S6 or one S8 gauge:



*Figure 2-10. Top View of S6 or one S8 Mounting on Upacting Press Brake*

## Die Retainer Plates with S7 Gauges

This figure represents an S7 gauge:

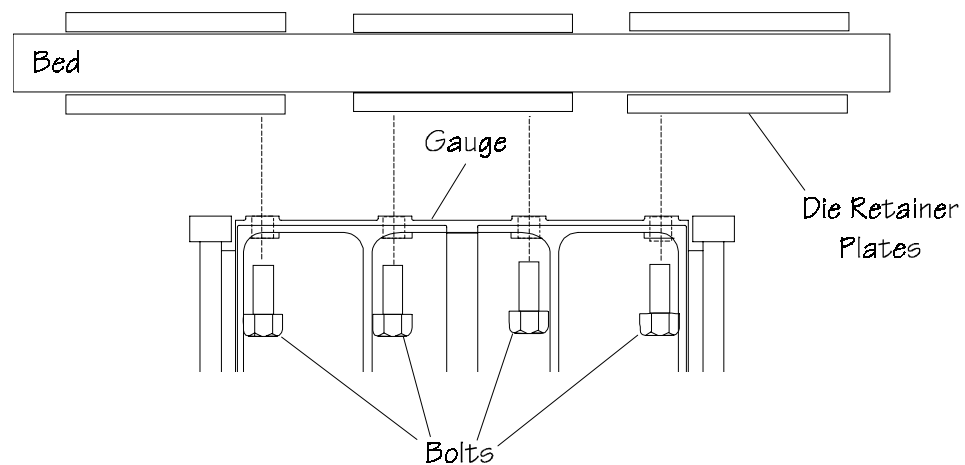

*Figure 2-11. Top View of S7 Mounting on Upacting Press Brake*



## Where can we go from here?

Proceed to the “Gauge Mounting” section of this chapter.

## Gauge Mounting

If gauge mounting holes need to be drilled and tapped, it is important to remember that different types of gauges have different mounting hole requirements. This section describes procedures for locating, drilling, and tapping mounting holes for different types of gauges and press brakes.

### Number of Gauge Mounting Holes

The number of mounting holes varies among the types of gauges:

<b>Gauge</b>	<b>Mounting Holes</b>
S6	2
S7	4
S8	4 (2 for each gauge)
LP11	2
LP21	4 (2 for each gauge)
LP22	4 (2 for each gauge)
LP22/54	4 (2 for each gauge)

## Gauge Height

Position the gauge so the gauge bar can be vertically adjusted to fit different die heights.

1. Locate the gauge's mounting holes approximately 10" below the top of the lowest die. (See the figure below.)
2. Use a plumb and level to ensure the mounting holes are parallel to the top of the press brake's bed.

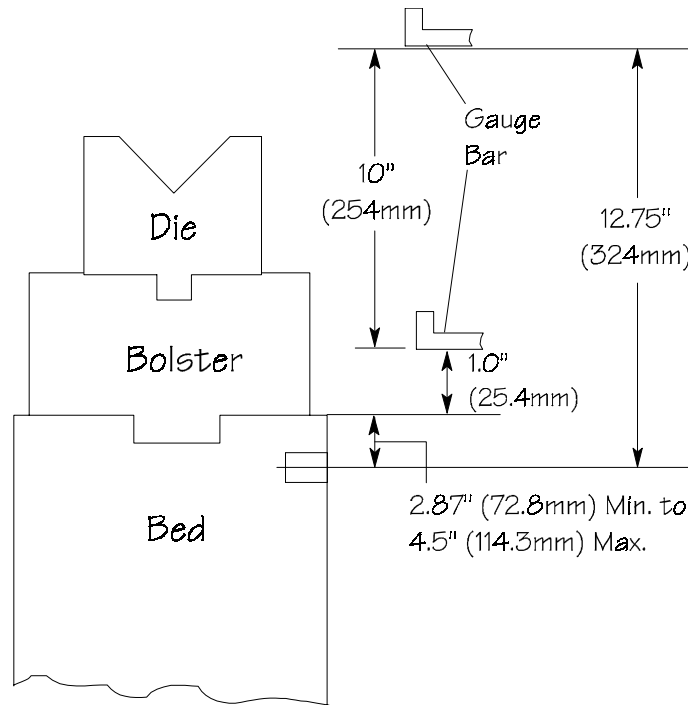

Side View of Typical Press Brake

*Figure 2-12. Configuration to Determine Gauge Mounting Height*



## S6 Gauge Mounting Hole Dimensions

This section contains measurements for correct placement of mounting holes for the S6 gauge and different types of press brakes.

### Hydraulic/Mechanical or Upacting Press Brakes

For hydraulic/mechanical or upacting press brakes, refer to these figures:

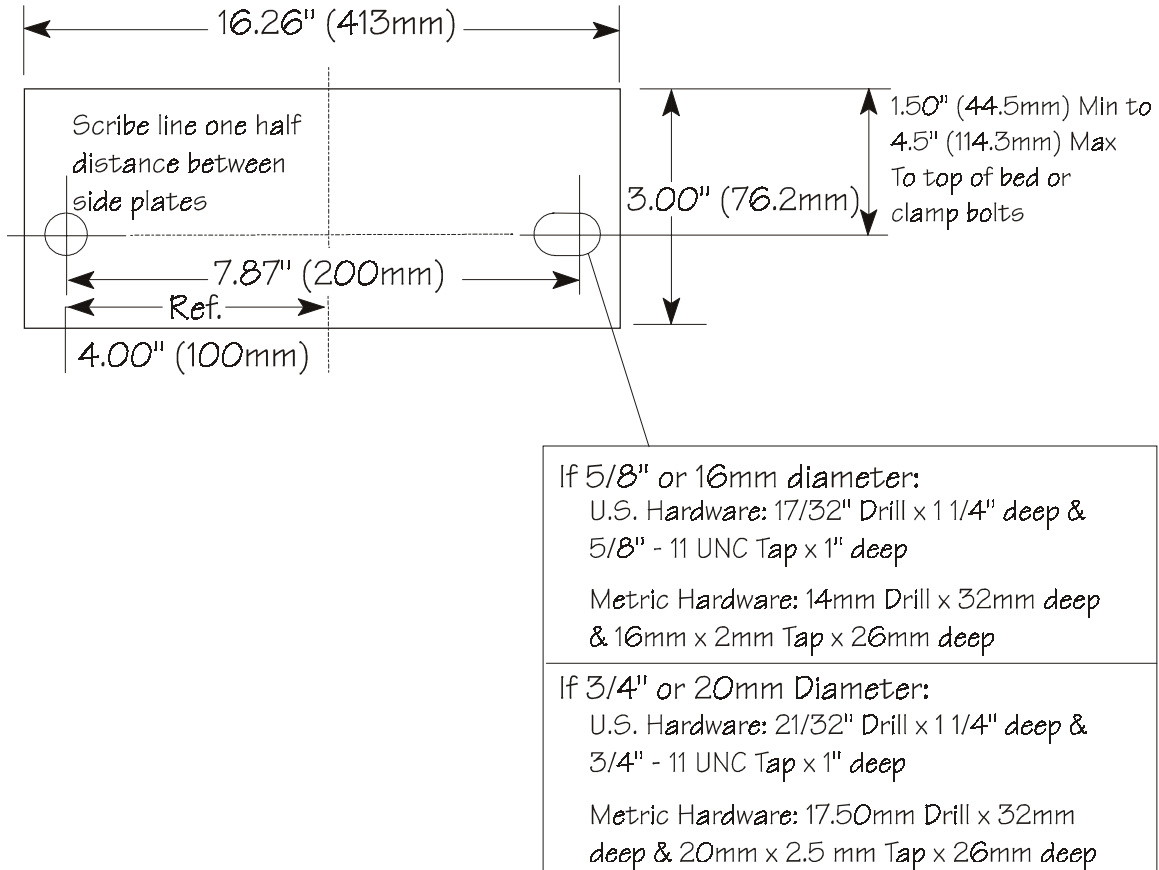

**Figure 2-13. S6 Gauge Mounting Pattern**

Komatsu Press Brakes

Autobend gauges are attached to Komatsu press brakes with mounting plates. For Komatsu press brakes, refer to these figures:

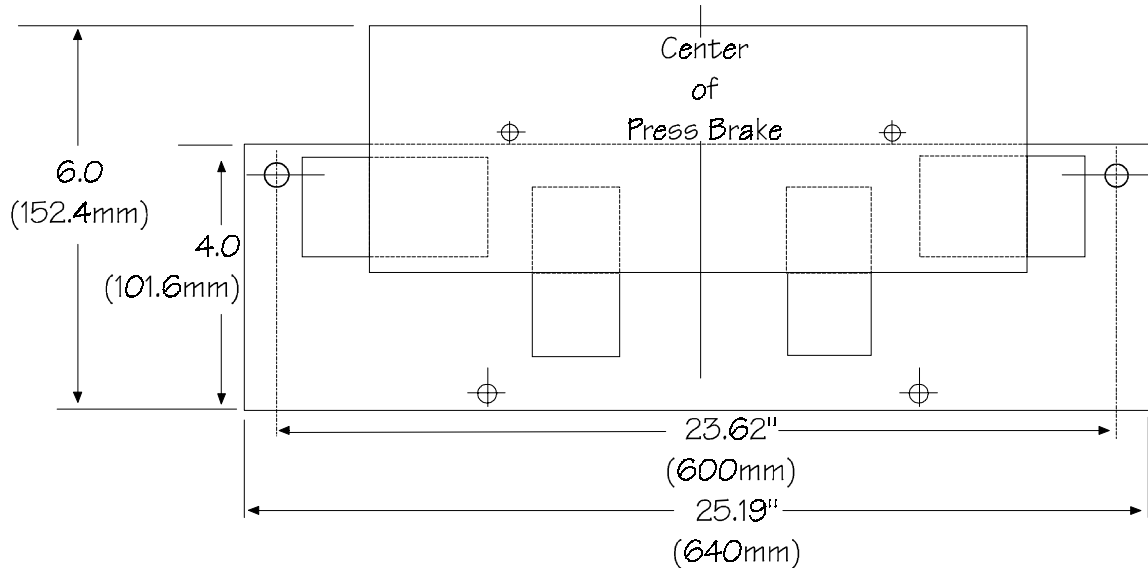

*Figure 2-14. Komatsu S6 Mounting Plate*

Drill and tap to the size and depth recommended in the figure below.

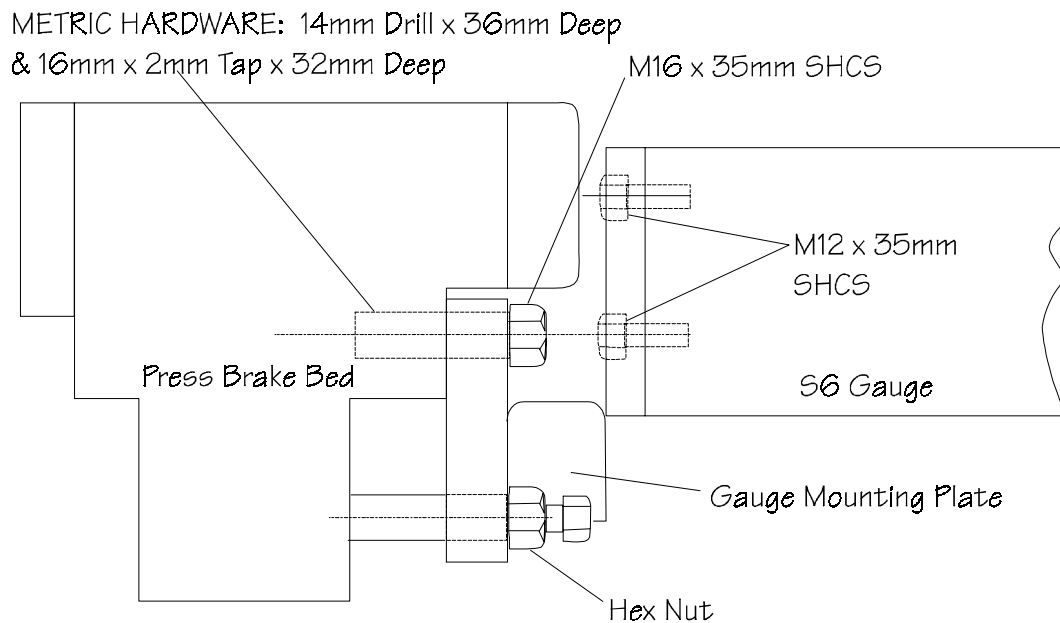

*Figure 2-15. Komatsu S6 Mounting Configuration*

Attach the mounting plate for the S6 gauge to the Komatsu press brake by following these instructions:

1. Position the mounting plate to the press brake.
2. Attach with the mounting bolts and washers.
3. Tighten the bolts securely.

**Note**

Adjust the leveling screws as required to prevent cocking and to level the gauge assembly.



**Where can we go from here?**

Proceed to the “Attaching Gauge to Press Brake” section in this chapter.

## S7 Gauge Mounting Hole Dimensions

This section contains measurements for correct placement of mounting holes for the S7 gauge and different types of press brakes.

### Hydraulic/Mechanical or Upacting Press Brakes

For hydraulic/mechanical or upacting press brakes, refer to this figure:

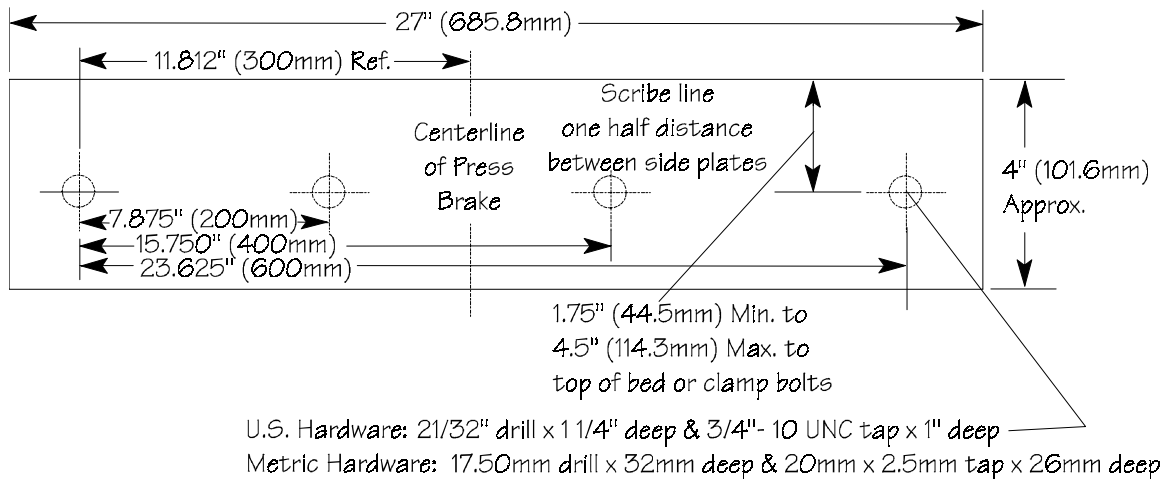

**Figure 2-16. S7 Mounting Pattern**



### Important

Remove the left and right covers from the S7 gauge. Do not re-install the covers until completing the cable connections as outlined in the "Electrical Connections" section of this chapter.

Komatsu Press Brakes

Autobend gauges are attached to Komatsu press brakes with mounting plates. For Komatsu press brakes, refer to these figures:

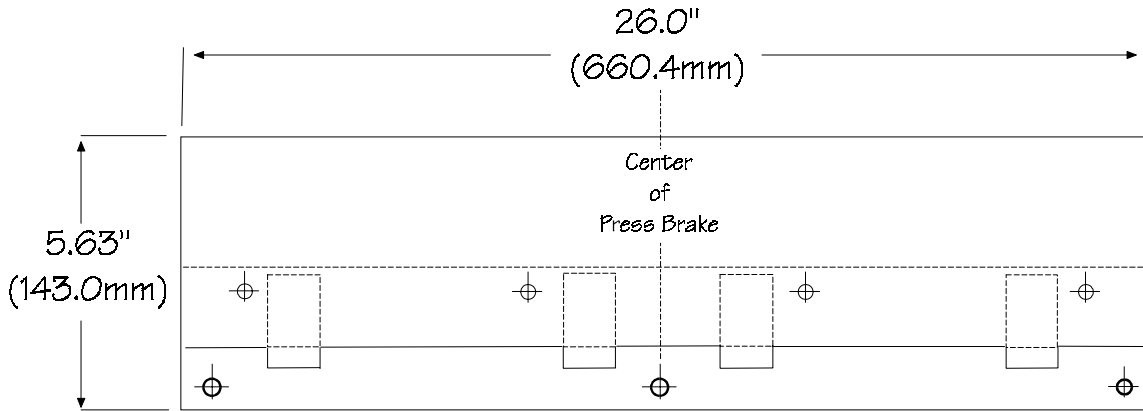

*Figure 2-17. Komatsu S7 Gauge Mounting Plate*

Drill and tap to the size and depth recommended in the figure below.

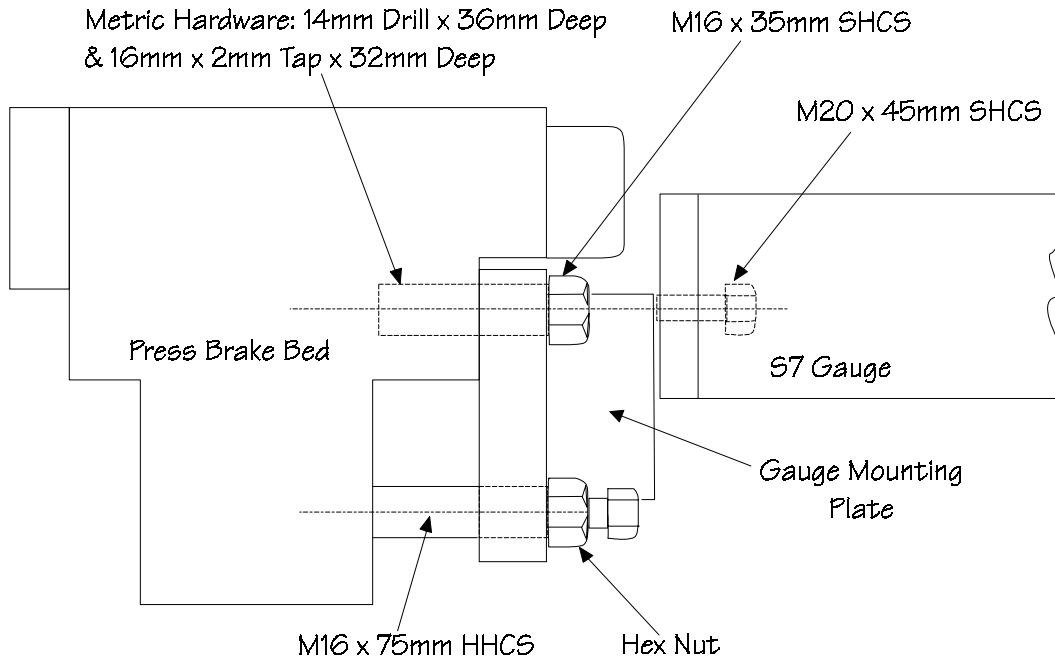

*Figure 2-18. Komatsu S7 Mounting Configuration*

Attach the mounting plate for the S7 gauge to the Komatsu press brake by following these instructions:

1. Position the mounting plate to the press brake.
2. Attach with the mounting bolts and washers.
3. Tighten the bolts securely.

**Note**

Adjust the leveling screws as required to prevent cocking and to level the gauge assembly.



**Where can we go from here?**

Proceed to the “Attaching Gauge to Press Brake” section in this chapter.

## LP11 Gauge Mounting Hole Dimensions

For hydraulic/mechanical or upacting press brakes, refer to this figure:

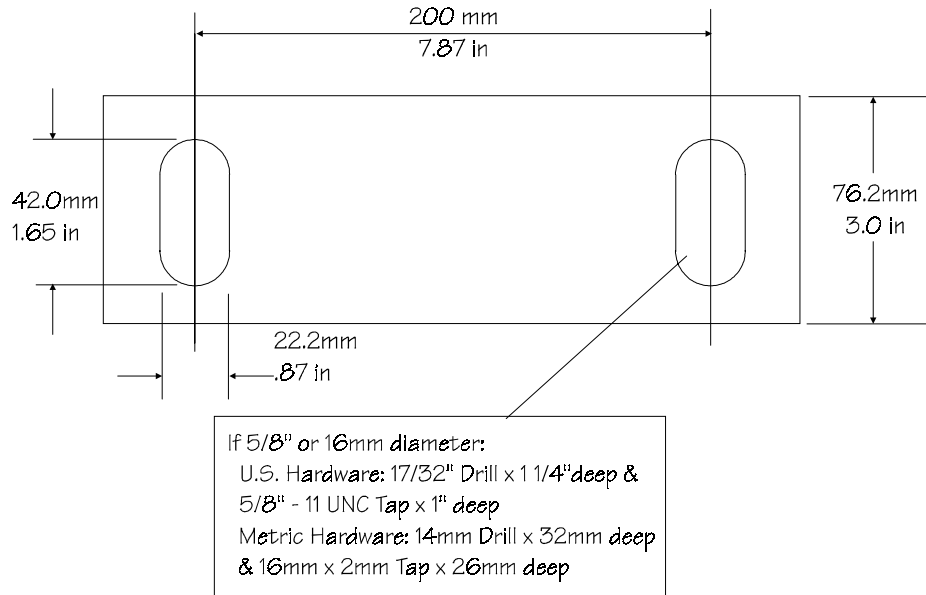

**Figure 2-19. LP11 Mounting Pattern**



### Where can we go from here?

Proceed to the “Attaching Gauge to Press Brake” section of this manual.

### Dual Gauge Mounting Hole Dimensions

This section contains measurements for correct placement of mounting holes for dual gauges and different types of press brakes.

#### S8 Gauges on Hydraulic/Mechanical or Upacting Press Brakes

For hydraulic/mechanical or upacting press brakes, refer to this figure:

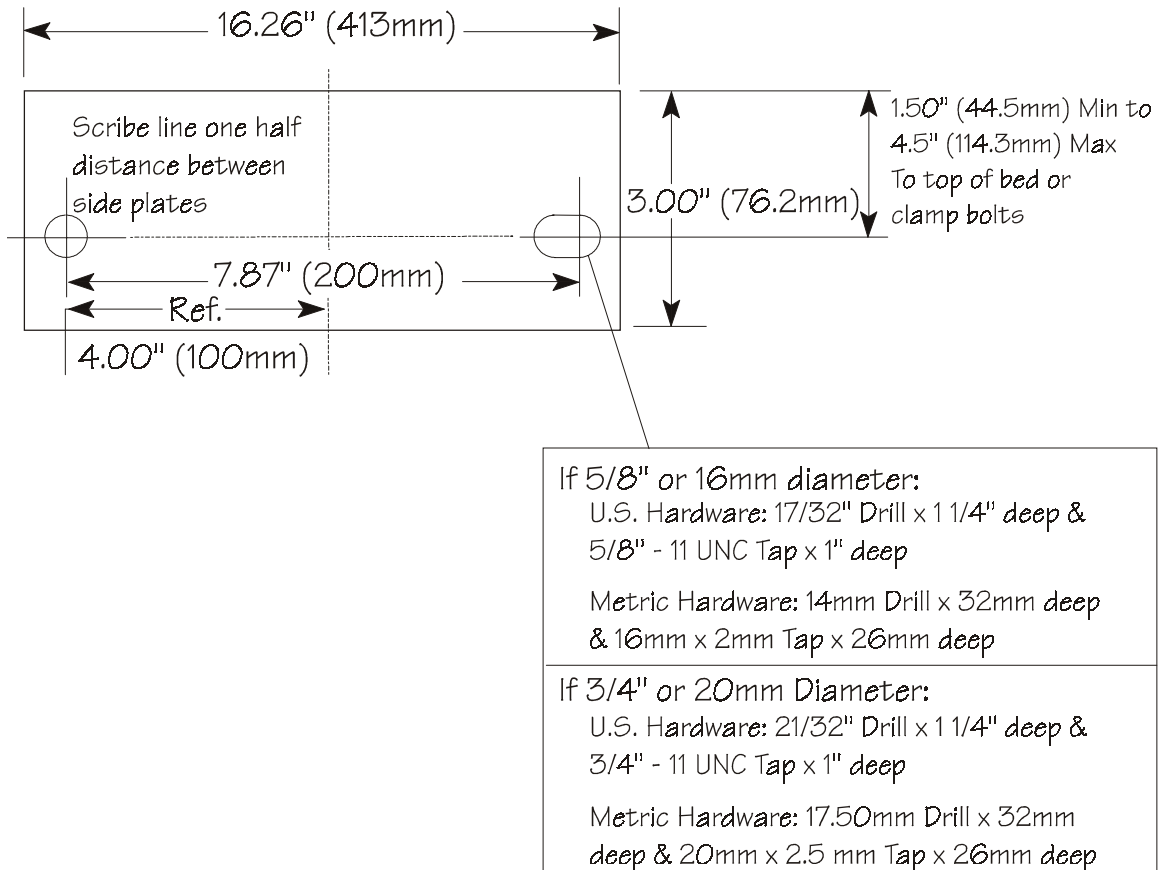
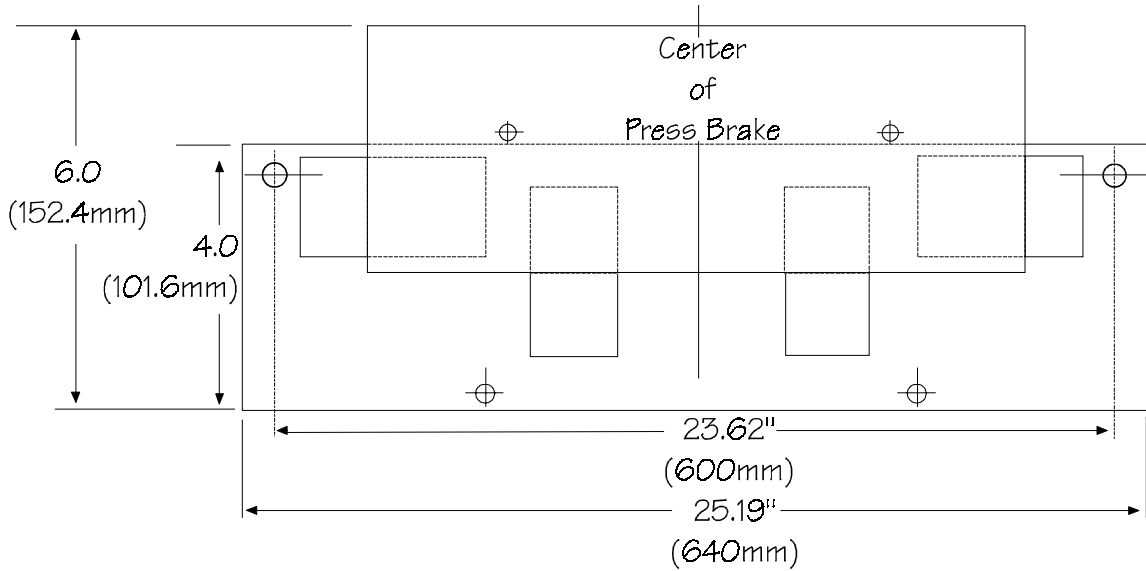

**Figure 2-20. S8 Mounting Pattern**



S8 Gauges on Komatsu Press Brakes

Autobend gauges are attached to Komatsu press brakes with mounting plates. For Komatsu press brakes, refer to these figures:



*Figure 2-21. Komatsu S8 Mounting Plate*

Drill and tap to the size and depth recommended in the figure below.

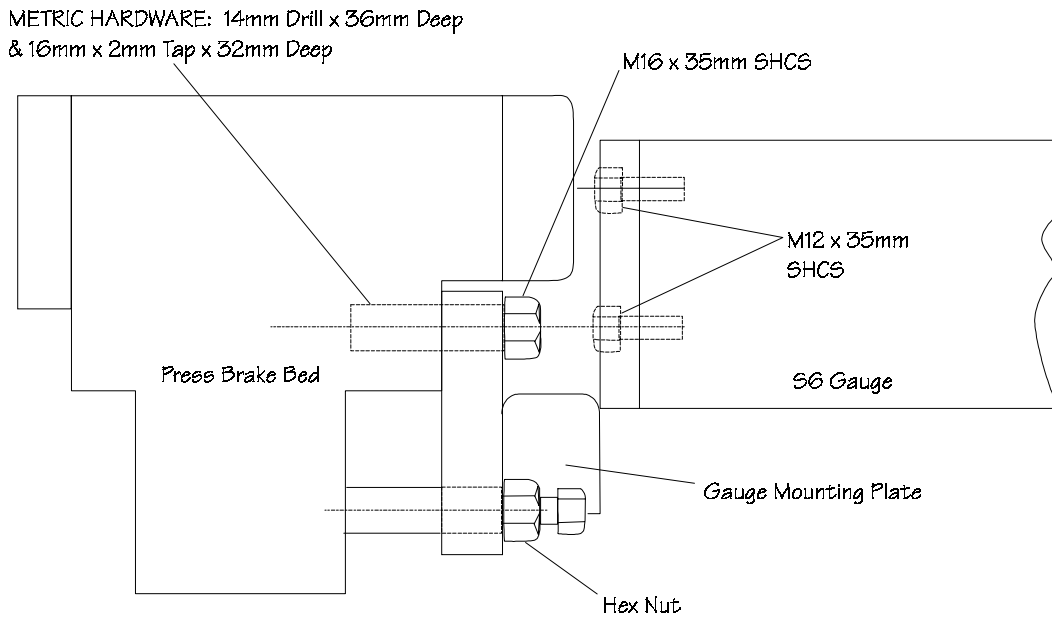

*Figure 2-22. Komatsu S8 Mounting Configuration*

Attach the mounting plate for the S8 gauge to the Komatsu press brake by following these instructions:

1. Position the mounting plate to the press brake.
2. Attach with the mounting bolts and washers.
3. Tighten the bolts securely.

**Note**

Adjust the leveling screws as required to prevent cocking and to level the gauge assembly.



**Where can we go from here?**

Proceed to the “Attaching Gauge to Press Brake” section in this chapter.

LP21 and LP22 Gauges—Hydraulic/Mechanical or Upacting Press Brakes

For hydraulic/mechanical or upacting press brakes, refer to this figure:

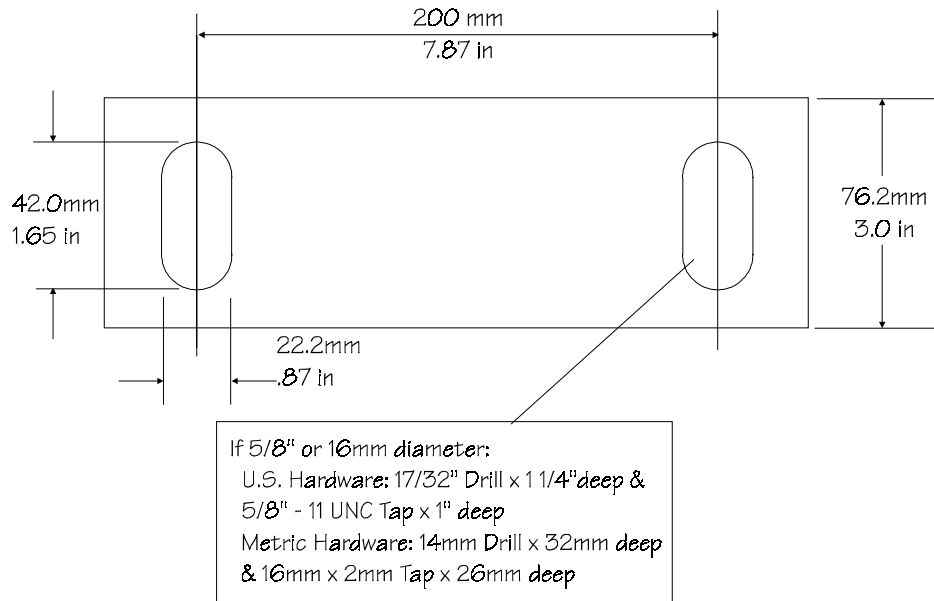

**Figure 2-23. LP21 and LP22 Mounting Pattern**

## X Dimension Tables for Dual Gauges

The location of the gauges for a dual gauge system is determined by measuring the length of the gauge bar and calculating the X Dimension from the centerline of the press brake. The X Dimension is the distance from the press brake's centerline to the inside bolt center for each gauge.

Refer to the appropriate X Dimension Table in this section and the "Mounting Dimensions for Dual Gauges" section to determine the correct location to mount the gauges.

<b><u>S8 Gauges on Hydraulic/Mechanical and Upacting Press Brakes</u></b>			
<b>X Dimension Table</b>			
Gauge Bar Length		X Dimensions from Centerline	
Inches	Millimeters	Inches	Millimeters
90	2286.0	22	560.0
96	2438.4	22	560.0
102	2590.8	27	700.0
108	2743.2	31	785.0
114	2895.6	31	785.0
120	3048.0	36	900.0
126	3200.4	36	900.0
132	3352.8	43	1100.0
138	3505.2	43	1100.0
144	3657.6	43	1100.0
150	3810.0	43	1100.0
156	3962.4	51	1300.0
162	4114.8	51	1300.0
168	4267.2	51	1300.0

*Table 1. S8 Gauges on Hydraulic/Mechanical and Upacting Press Brakes—  
X Dimension*

<b><u>S8 Gauges on Komatsu Press Brakes</u></b>			
<b>X Dimension Table</b>			
Gauge Bar Length		X Dimensions from Centerline	
Inches	Millimeters	Inches	Millimeters
90	2286.0	27.56	700.0
96	2438.4	27.56	700.0
102	2590.8	27.56	700.0
108	2743.2	35.43	900.0
114	2895.6	35.43	900.0
120	3048.0	35.43	900.0
126	3200.4	35.43	900.0
132	3352.8	43.31	1100.0
138	3505.2	43.31	1100.0
144	3657.6	43.31	1100.0
150	3810.0	43.31	1100.0
156	3962.4	51.18	1300.0
162	4114.8	51.18	1300.0
168	4267.2	51.18	1300.0

*Table 2. S8 Gauges on Komatsu Press Brakes—X Dimension*

<b><u>LP22, LP22/54 Gauges on Hydraulic/Mechanical and Upacting Press Brakes</u></b>			
<b>X Dimension Table</b>			
Gauge Bar Length		X Dimensions from Centerline	
Inches	Millimeters	Inches	Millimeters
72	1828.8	16.94	430.0
90	2286.0	25.94	659.0
114	2895.6	34.94	888.0
120	3048.0	39.94	1015.0
138	3505.2	46.94	1192.0

*Table 3. LP22 and LP22/54 Gauges on Hydraulic/Mechanical Press Brakes—  
X Dimension*

<b><u>LP21 Gauges on Hydraulic/Mechanical and Upacting Press Brakes</u></b>		
<b>X Dimension Table from Centerline</b>		
Gauge Size	Inches	Millimeters
1.5 M	11.81	300.0
2.0 M	19.69	500.0
2.5 M	27.56	700.0
3.0 M	35.43	900.0
4.0 M	43.31	1100.0

*Table 4. LP21 Gauge on Hydraulic/Mechanical Press Brakes—  
X Dimension*

## Mounting Dimensions for Dual Gauges

Refer to the X Dimension tables in the previous section and the appropriate figure below to determine the location for dual gauges.

### S8 Gauges on Hydraulic/Mechanical and Upacting Press Brakes

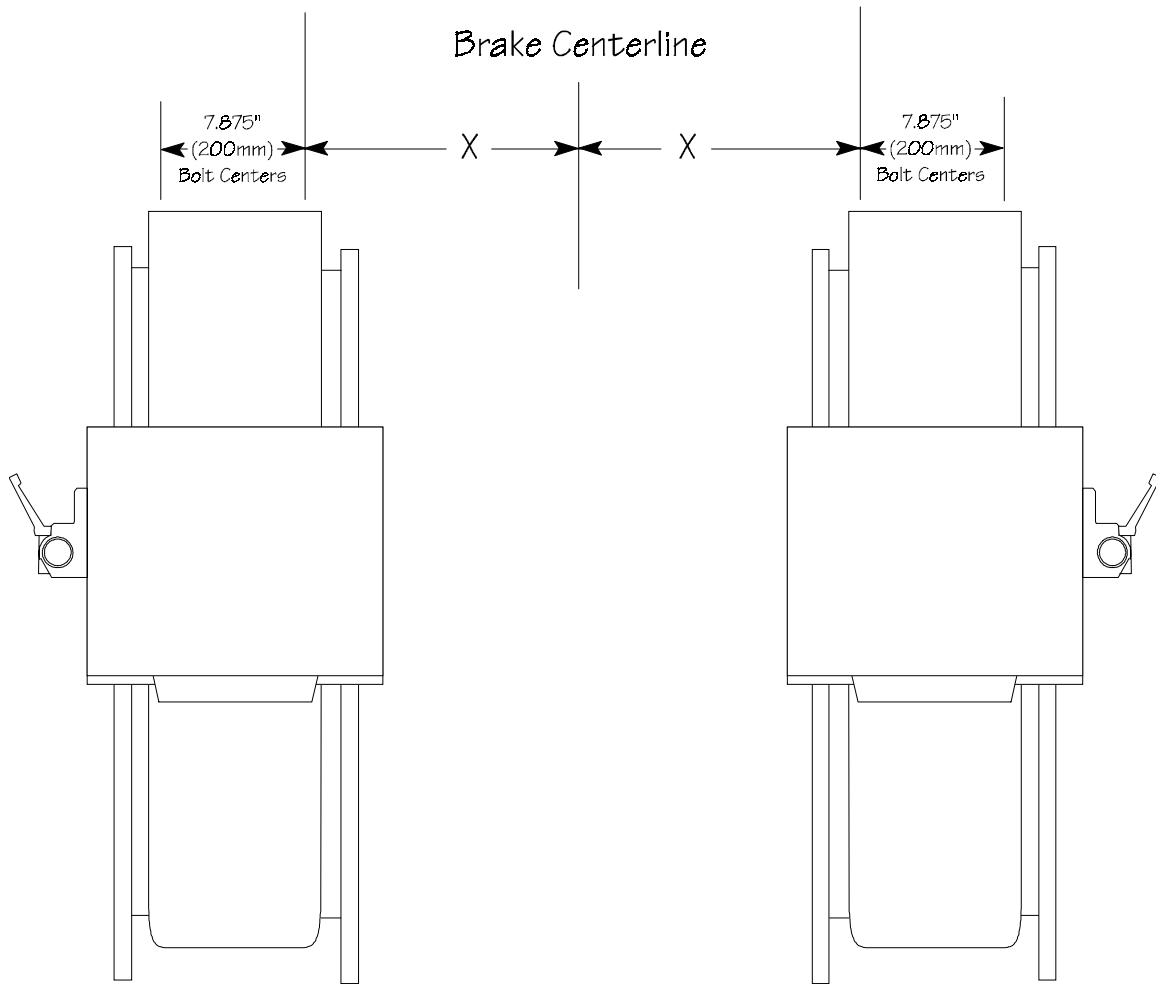

**Figure 2-24. S8 Mounting Dimensions—Hydraulic/Mechanical and Upacting Press Brake**

S8 Gauges on Komatsu Press Brakes

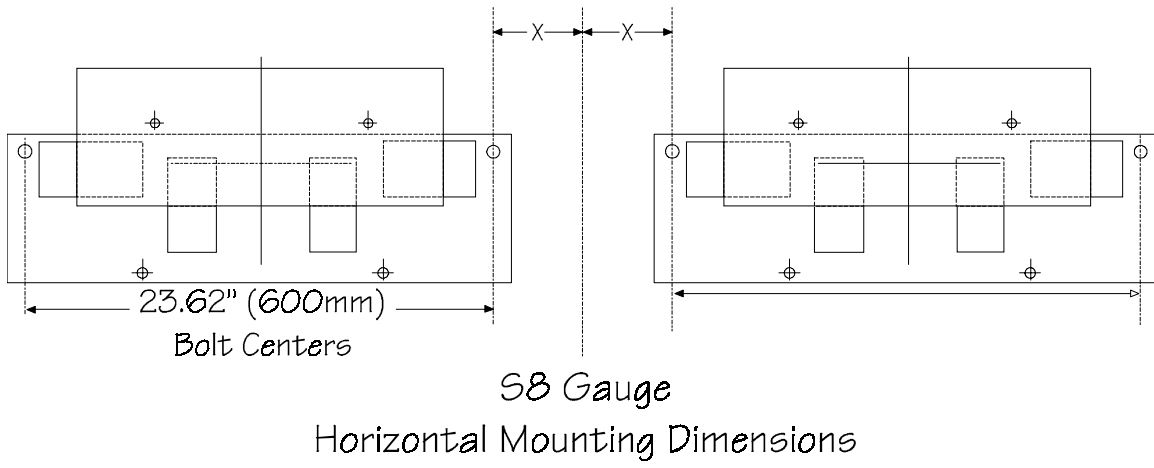

*Figure 2-25. S8 Mounting Dimensions—Komatsu Press Brake*



LP21, LP22, LP22/54 Gauges—Hydraulic/Mechanical, Upacting Press Brakes

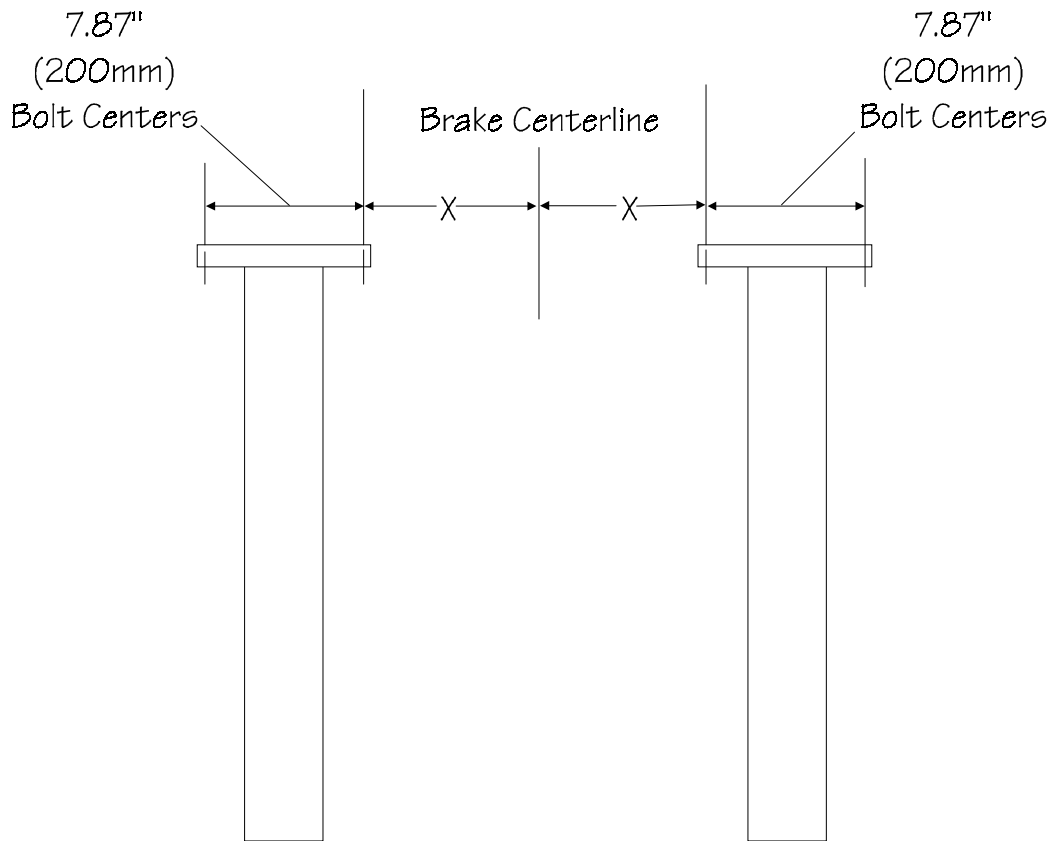

*Figure 2-26. LP21 and LP22 Mounting Dimensions—Hydraulic/Mechanical and Upacting Press Brake*



**Where can we go from here?**

Proceed to the “Attaching Gauge to Press Brake” section of this manual.

## Vertical Mounting for S8 Gauges

For vertical installation of the S8 gauge, use mounting brackets to attach the dual housing assemblies to the inner surface of the press brake's side walls. Each gauge uses two brackets, one attached to each end. To ensure the best performance and reliability, align these brackets parallel to the top of the press bed. Before drilling the mounting holes, position the gauge at a height so the gauge bar can be vertically adjusted to fit different die heights.

Follow these instructions to vertically mount S8 gauges:

1. Scribe a horizontal line on both side frames using the top of the press bed as a basic reference point. Using a plumb and level, extend this line the full length of the side frame.

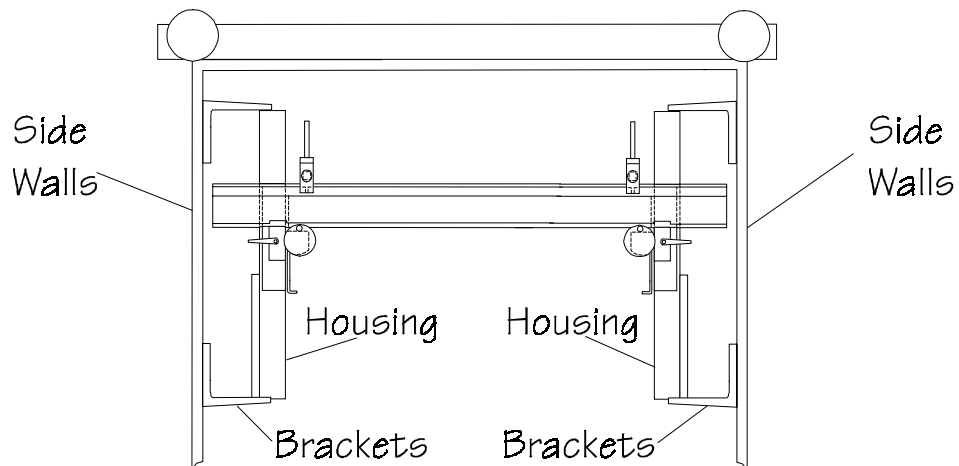

*Figure 2-27. Top View of Vertical S8 Gauge*

2. Locate the centerline of both the forward and rear mounting brackets' holes (see the figure below). Mark the centers of the mounting holes.
3. Carefully drill and tap the eight bolt holes to the recommended sizes and dimensions (see the figure below).

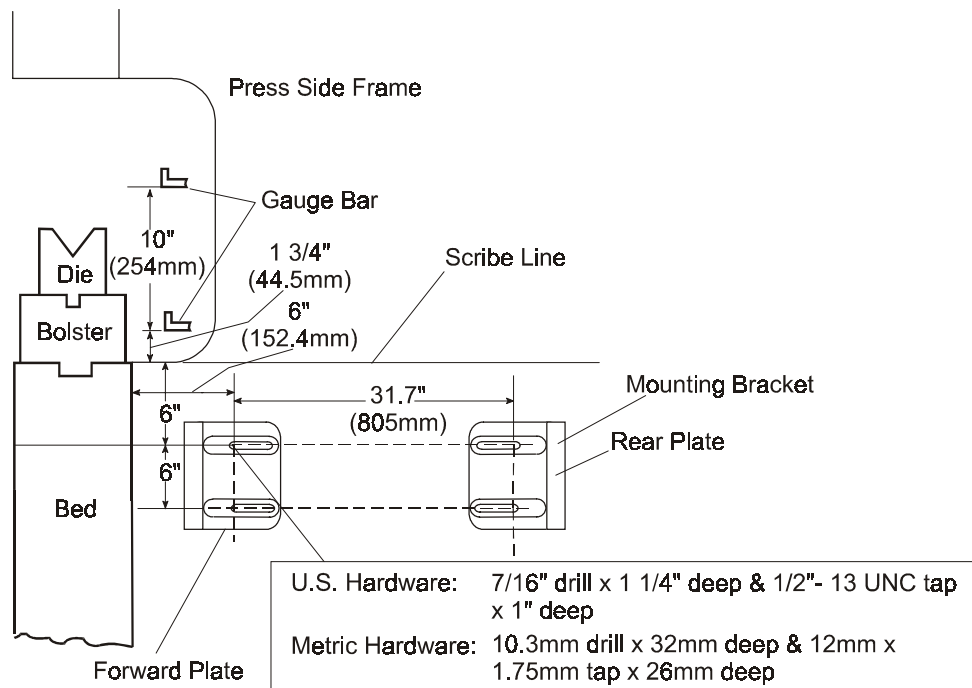
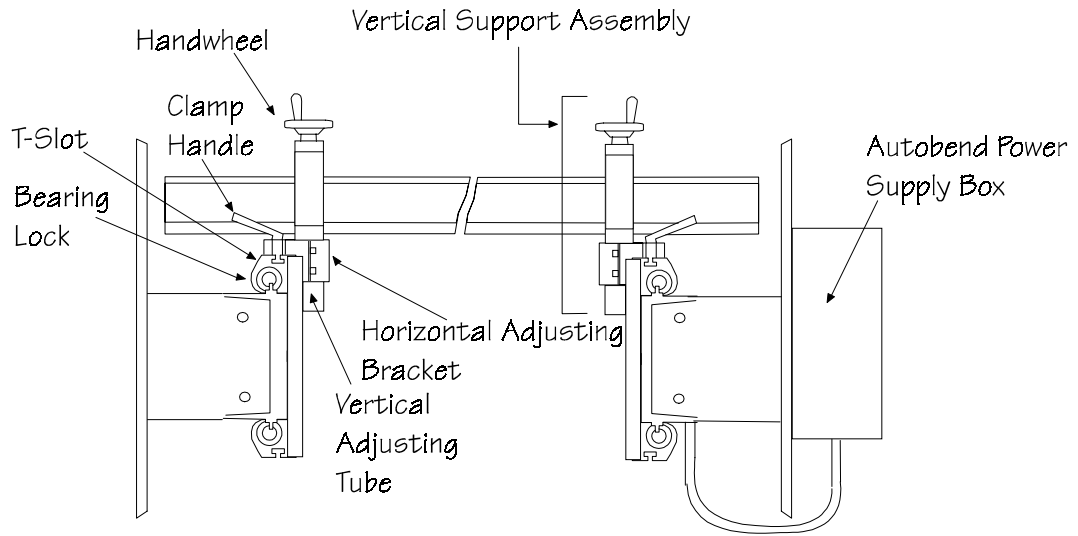

Figure 2-28. Side View of Typical Press Brake

4. Loosely attach the gauges' mounting brackets to the side frames, using the screws and flat washers provided.
5. Remove the Autobend S8 name plates at the rear of each gauge.
6. To prevent each gauge cable (harness) from becoming entangled with the lead screw when the gauges are mounted vertically, secure the cable to the gauge frame with tie wraps.
  - a. Use the 15/64" drill bit and drill one hole in each gauge frame for connecting the tie wraps. Each hole should be located 8" from the rear and 1/2" up from the bottom.
  - b. Insert the self tapping screws, and attach one tie wrap to each frame.

Here is a vertical S8 gauge configuration:



*Figure 2-29. Rear View of Vertical S8 Model Gauge*

## Attaching Gauge to Press Brake

Attach the gauge(s) to the rear of the press brake.

1. Position the gauge(s) to the press and install the mounting bolts and washers. Tighten the bolts securely against the washers.
2. Wipe down the lead screw and carriage ways with a soft, lint-free cloth. Apply a light film of S.A.E. #10 machine oil to the lead screw and both rod ways.

### Note

Hurco and Mebusa press brakes require a spacer plate between the die retainer plates and each LP21 gauge. These spacer plates raise the gauges so they clear the top of the back cover.

An additional spacer plate is required for inch/metric adjustment for an R axis with the LP21 gauge. Alignment between the left and right sides is critical for proper operation.

## Attaching LP21 Rear Cover Kit Assembly

LP21 gauge assemblies consist two sides, a rear connector which attaches the two sides together, and one motor. Refer to Hurco Part Number 001-2010-008/009/010. First mount the two sides, then assemble the rear connecting shaft, support bearing assemblies, and couplings.

1. Install the rear connecting channel between the two (2) gauges with four (4) M6 x 16 SHCS and flat washers. Use the two (2) pre-drilled slots at each end of the channel.
2. Install the rear support bearing into the rear support bearing housing with the two (2) M5 x 10 BHCS and flat washers in the side of the housing block.
3. Measure the total distance between the two (2) gear box shafts that face each other. Cut the rear connecting shaft 1.12" shorter than this measurement.
4. Install the rear support bearing assemblies from above onto the shaft. Do not tighten the two (2) bearing set screws.

5. Slide one (1) coupling hub onto the end of each of the gear boxes and connecting shafts.

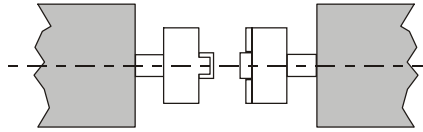

*Figure 2-30. Coupling Hubs*

6. Push both gauge carriages as far as possible toward the front of the press brake to ensure left and right alignment. The gauges should bottom out on the mounting screws.
7. Center the connecting rod assembly and install inside the channel by aligning the blocks. Use two (2) M6 x 16 SHCS to secure blocks. Do not tighten screws .



### **Important**

Make sure the carriages are evenly aligned.

8. Insert the plastic disks inside the two coupling hubs of the gear box.
9. Rotate the coupling hub so you can tighten it. The inside holes should be on top, and the outside holes should be on the bottom. Make sure the end of the gearbox shaft is flush with the inboard face of the coupling.
10. Tighten the outside coupling (the top hole).
11. Slide the inside coupling hub to engage the plastic disk on the outside coupling hub.
12. Tighten the bottom hole on the inside coupling hub.
13. Tighten the bearing support housing block's screws.
14. Test before installing the covers. Operate with the control to ensure the left and right gauges are the same distance from the die.

15. Install the covers:
  - a. Right rear connecting cover — use two (2) M6 x 16 BHCS and flat washers.
  - b. Left rear connecting cover — use two (2) M6 x 16 BHCS and flat washers.
  - c. Center rear connecting cover — use two (2) M6 x 16 BHCS and flat washers.
  - d. Rear Cover strap — use four (4) M6 x 16 BHCS and flat washers (2 with washers in back and 2 with washers and nuts).

## Attaching Adjustable Leg Assembly for LP22/54 Gauges

The length of the LP22/54 gauges requires leg assemblies for support. Follow these steps to attach the legs:

1. Make sure the gauge is level front to back.
2. Attach the LP22/54 gauges to the adjustable leg assemblies with the bolts provided.
3. Secure the adjustable leg assemblies to the floor in a safe manner.

### Note

Hurco cannot provide hardware for securing the leg assembly to the floor since floor types vary.



### Where can we go from here?

- Consult the “Maintenance” chapter for maintenance procedures.
- Proceed to the “Gauge Bar and Mounting Devices” section of this chapter.



## Gauge Bars and Mounting Devices

Following are instructions for installing different types of gauge bars to the gauge with vertical supports.

### Vertical Supports

Vertical supports are manually adjusted so the gauge bar can produce different bends. The handwheel allows approximately three inches of fine vertical adjustment. Use the lower horizontal adjusting bracket to make coarse vertical movements. A T-slot in the gauge bearing block provides horizontal movement relative to the tooling.

Here is a vertical support for S6, S7, or S8 gauges:

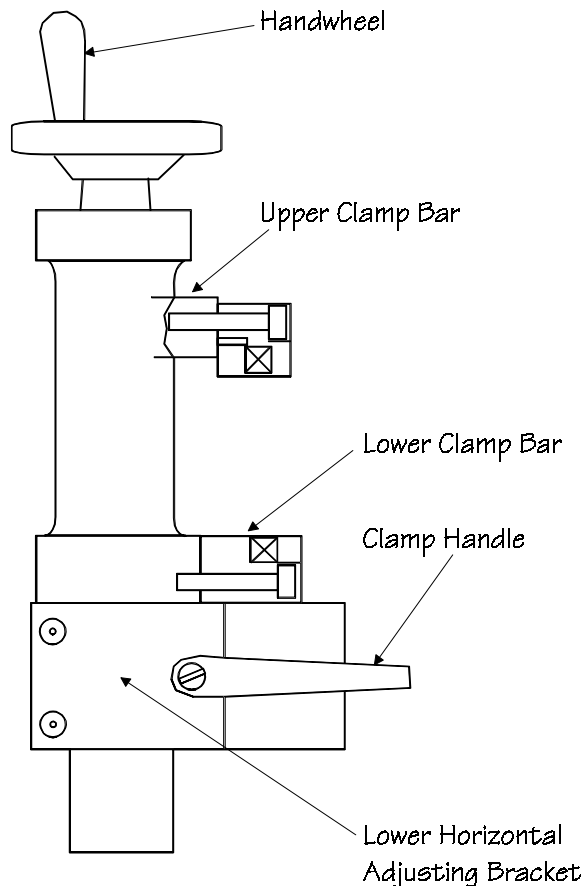

*Figure 2-33. S6, S7, and S8 Vertical Support Assembly*

## **S6, S7, S8, and Vertical S8 Gauges**

Follow these steps to install vertical supports to S6, S7, and S8 gauge bars:

1. Adjust both vertical supports to the same length.
2. Placing the clamp handle and T-nut to the rear, slide the vertical supports an equal distance into the T slot in the bearing blocks.
3. Tighten the clamp handle slightly when in position.



### **Where can we go from here?**

Proceed to either the “Y-Shaped Rigid Gauge Bar” or “Tilting Gauge Bar” section of this chapter.

## LP11, LP21, and LP22 Gauges

Install vertical supports to LP11 and LP22 gauge bars as follows:

1. Remove the two (2)  $3/8$ "-16  $\times$  1 SHCS from the bottom of the support assembly.
2. Insert the vertical supports into the corresponding sockets on the outside of the gauge carriage. Also, keep the horizontal bar on the outside of the supports.
3. Re-install the two screws and tighten.

Here is a vertical support for LP11, LP21, or LP22 gauges:

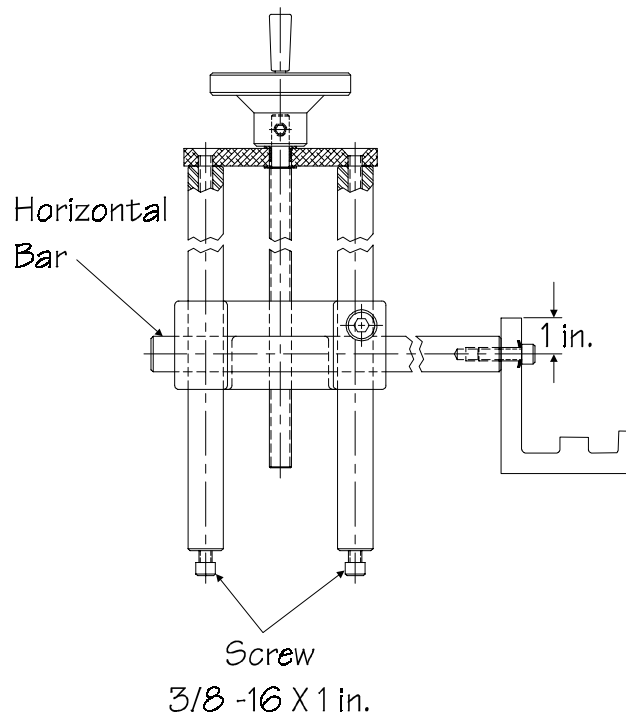

*Figure 2-34. LP11, LP21, and LP22 Gauge Bar and Vertical Supports*



### Where can we go from here?

Proceed to the “LP11 and LP22 Gauge Bar” section of this chapter.

## Gauge Bars

The Autobend utilizes three types of gauge bars: the *Y-Shaped Rigid Gauge Bar*, the *Tilting Gauge Bar*, and the *LP11, LP21, and LP22 Gauge Bar*. Following are instructions for installing each type.

### Y-Shaped Rigid Gauge Bar

The Y-Shaped Rigid Gauge Bar is installed on Autobend's S6, S7, and S8 gauges. Vertical supports hold it to the gauge. This type of gauge bar provides an accurate positive stop for the material being bent. *Flip fingers* installed on the gauge bar provide clearance for the material as it is bent.

To install the Y-Shaped Rigid Gauge Bar, follow these instructions:

1. Loosen the socket head cap screws of the upper and lower clamp bars located on the vertical supports (see the figure below).

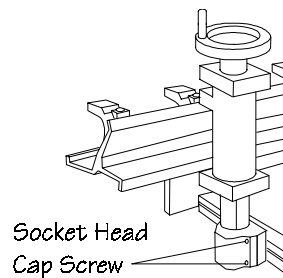

*Figure 2-35. Position of Gauge Bar and Vertical Supports*

2. Insert compression springs into the cavities of both the lower and upper clamp bars. See the figure on the following page.
3. Install the lower clamp bars with just a few turns of the screws.
4. Position the Y-shaped gauge bar into the lower clamp bars and tighten slightly.
5. Install the upper clamp bars and compression springs, tightening slightly.
6. Using a level, check the gauge surface and make any necessary adjustments to position the gauge bar both vertically and horizontally.
7. Tighten the upper and lower clamp bars securely.

Refer to the figure below when installing a Y-Shaped Rigid Gauge Bar:

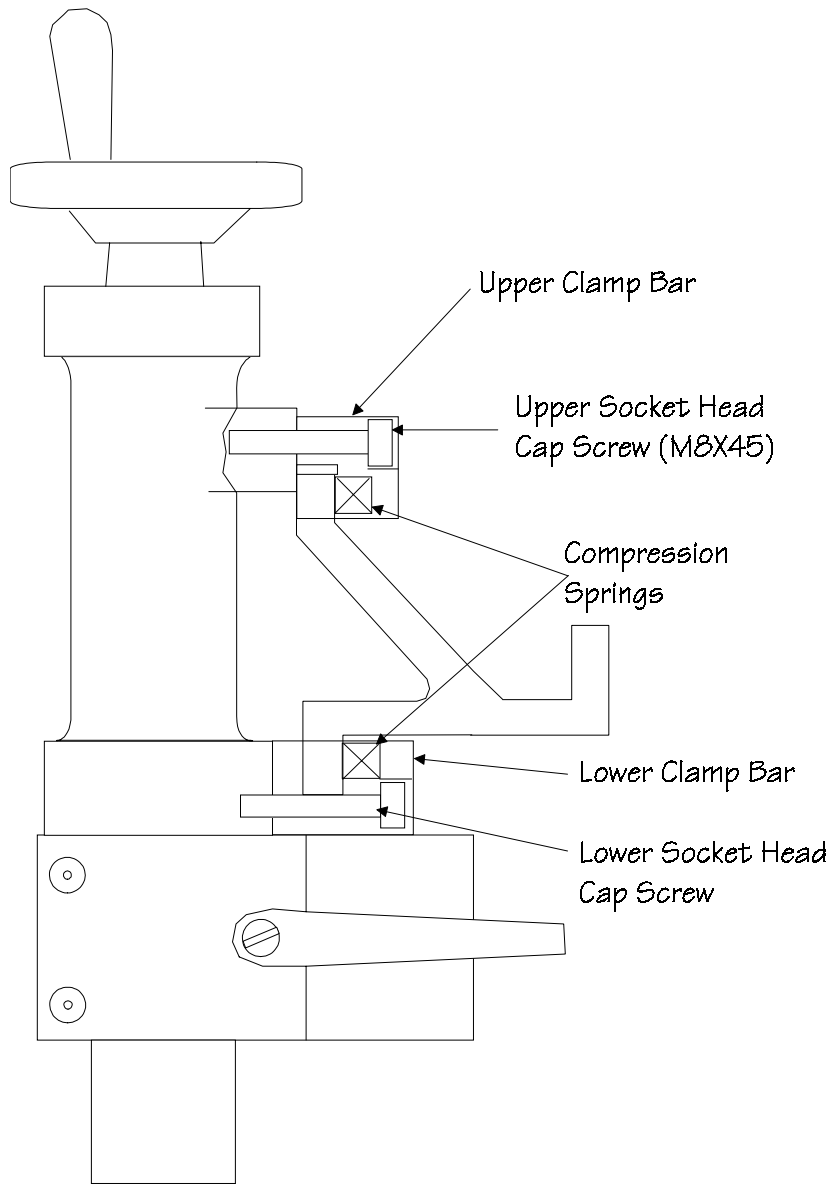

*Figure 2-36. Vertical Support and Y-Shaped Rigid Gauge Bar*



### **Where can we go from here?**

Proceed to the “Carriage Arrestor Bar” section of this chapter.

## Tilting Gauge Bar

The Tilting Gauge Bar is installed on Autobend's S6, S7, and S8 gauges. *Steel wear plates* on the front of the aluminum gauge bar protect it from the metal being formed as they make contact. *Vertical supports* hold the bar to the gauge. This type of gauge bar pivots; the tilting action provides clearance for the material as it is bent.

1. Loosen the socket head cap screws of the upper and lower clamp bars located on the vertical supports (see the figure below).

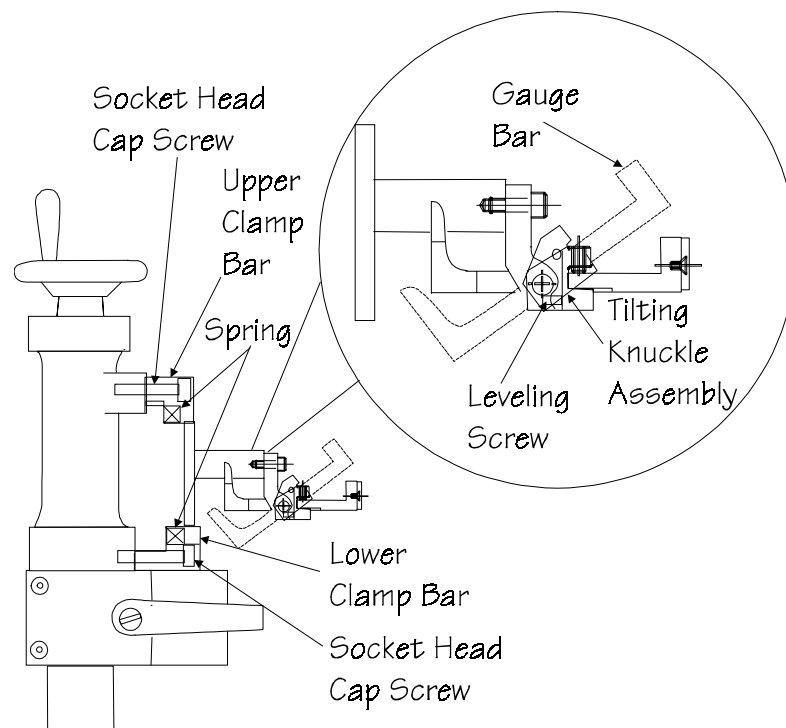

**Figure 2-37. Vertical Support and Tilting Gauge Bar**

2. Insert compression springs into the cavities of both the lower and upper clamp bars.
3. Install the lower clamp bars with a few turns of the screws.
4. Position the tilting knuckle assemblies into the lower clamp bars and tighten slightly.
5. Install the upper clamp bars and compression springs, tightening slightly.

6. Position the gauge bar into the tilting clamps, tightening the set screws to hold the bar into position. Verify that after the bar tilts it returns to a level position. Adjust the leveling screw as necessary to maintain this movement.
7. Tighten all cap screws.



### **Where can we go from here?**

Proceed to the “Carriage Arrestor Bar” section of this chapter.

## LP11, LP21, and LP22 Gauge Bar

The LP11, LP21, and LP22 gauge bar is installed on Autobend's LP gauges. Vertical supports hold the bar to the gauge. Follow the procedures below to install these gauge bars:

1. Measure the distance between the horizontal shafts on the two LP series vertical supports.
2. Record the distance.
3. Transfer the measurement to the back of the gauge bar. Keep the beginning and end points of the measurement centered on the bar.
4. Drill one (1)  $7/16$ " hole at each end 1" from the top rear of the gauge bar. See the figure below.
5. Mount the bar.
6. Tighten the cap screws and spring washers.

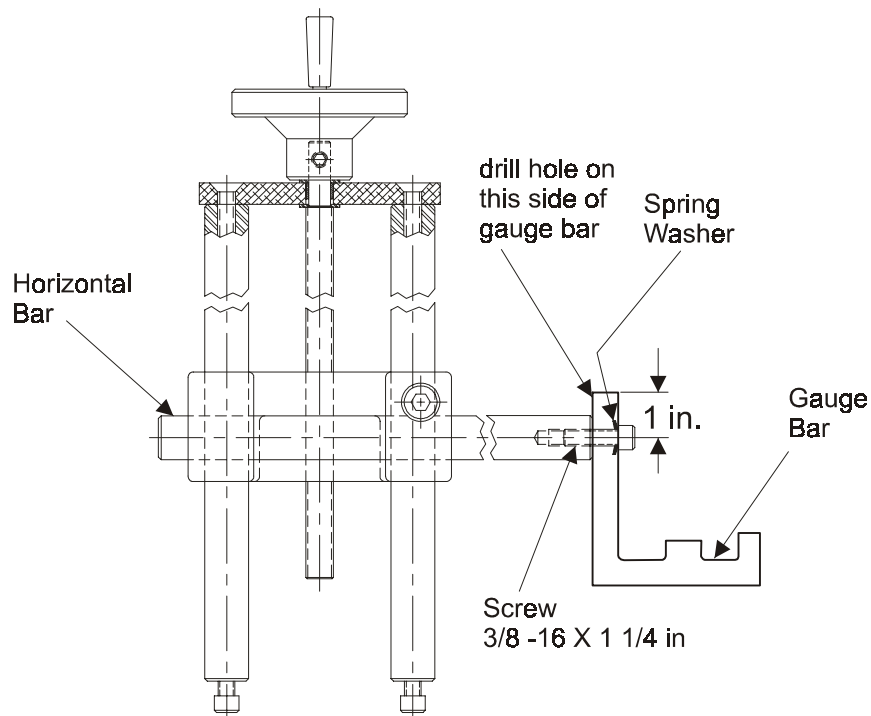

*Figure 2-38. LP11, LP21, and LP22 Gauge Bar and Vertical Supports*



## Carriage Arrestor Bars

Use carriage arrestor bars for *safety devices*. They consist of two plates that clamp to each gauge frame and provide a forward positive hard stop for the carriage. Place each arrestor bar at a point that prevents the gauging surface from interfering with the forming tools. Set them in the correct position each time after a tooling change and/or re-referencing the gauge bar.

Refer to the figure below for the S6 or S8 gauge.

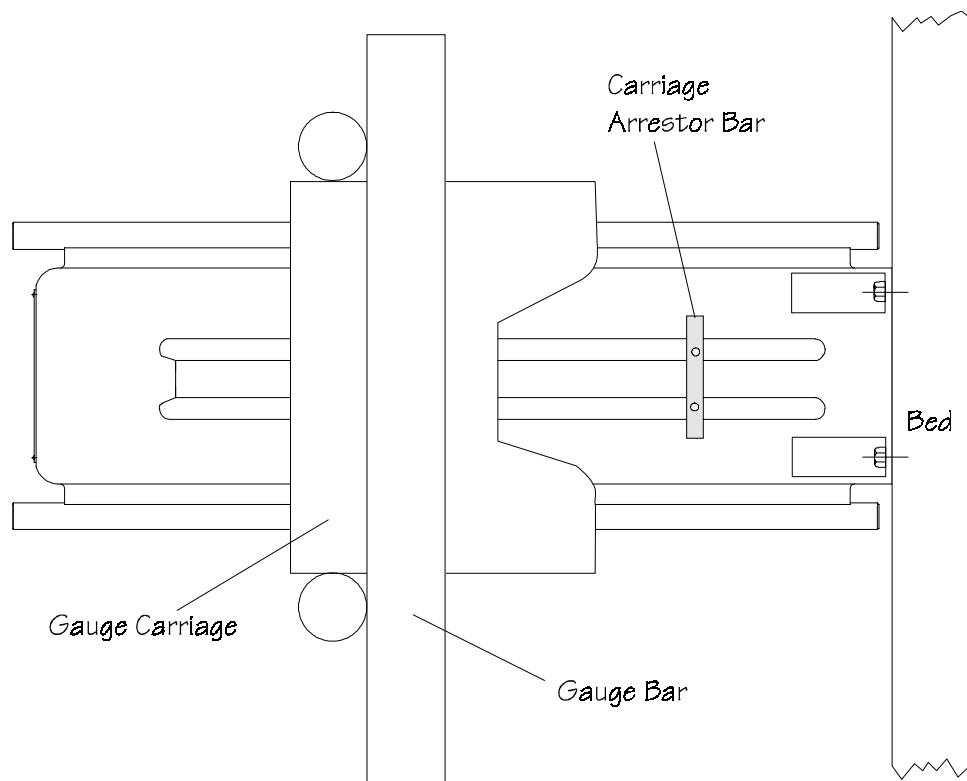

**Figure 2-39. Carriage Arrestor Bar on S6 or one S8 Gauge**

Refer to the figure below for the S7 gauge.

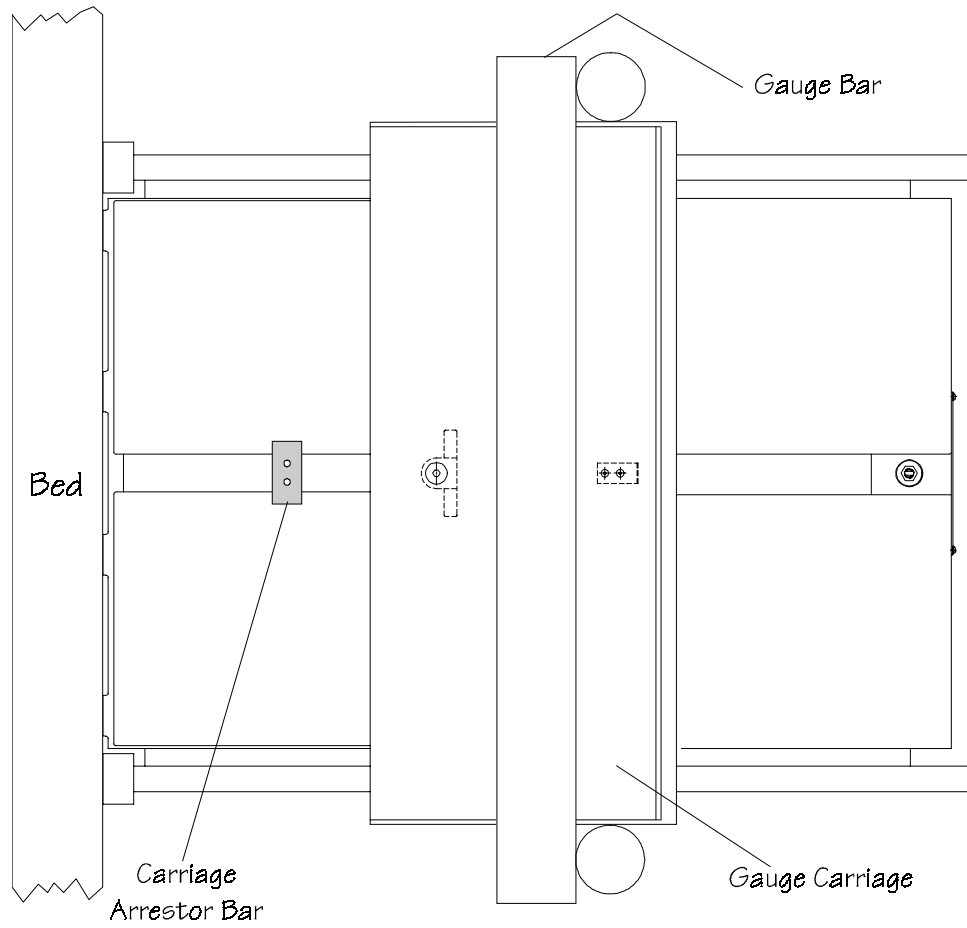

*Figure 2-40. Carriage Arrestor Bar on S7 Gauge*

Follow these instructions to install the carriage arrestor bars:

1. Remove the screws from the carriage arrestor bars and separate the clamp into two pieces.
2. Sandwich the clamp plates around the gauge, replace the screws, and tighten them until the clamp just slides.
3. Set the final position by sliding the gauge carriage forward to the desired hard stop position.

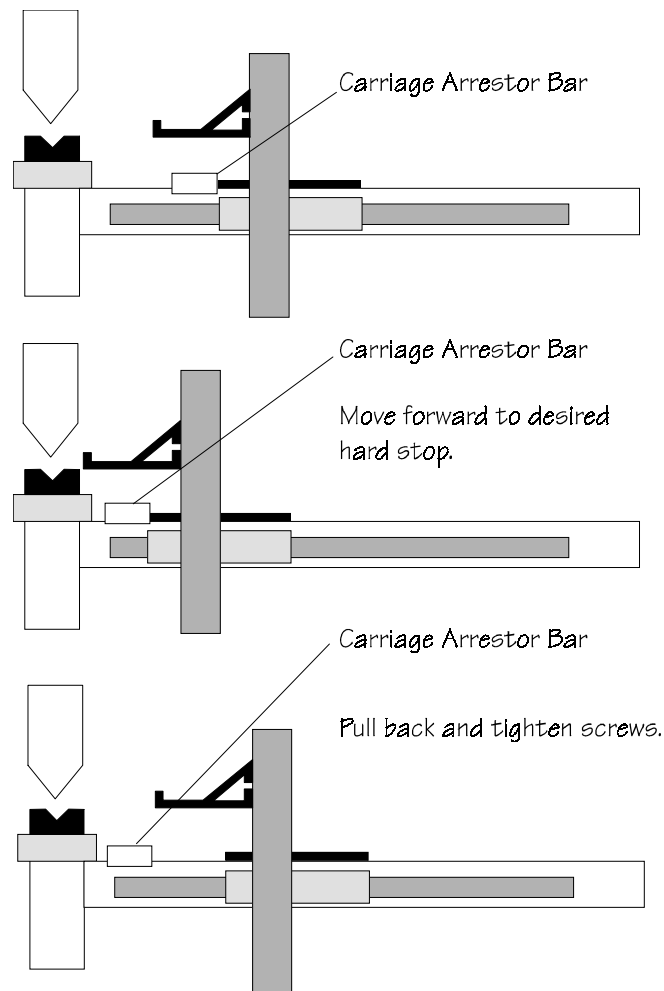

*Figure 2-41. Side View of Press Brake and Gauge Bar with Carriage Arrestor Bar*

4. Pull the gauge carriage back to expose the carriage arrestor bars.
5. Tighten the screws to lock the carriage arrestor bars.

## Selecting the Gauging Surface

The Autobend gauge bar provides various methods of referencing the material to be formed. For best results do not place material directly against the front edge or face of the gauge bar. This surface should be used to hold the flip fingers and gauge blocks suited to this task. Ideally using two stops per bend is recommended since tooling centerlines and material edges are typically not straight.

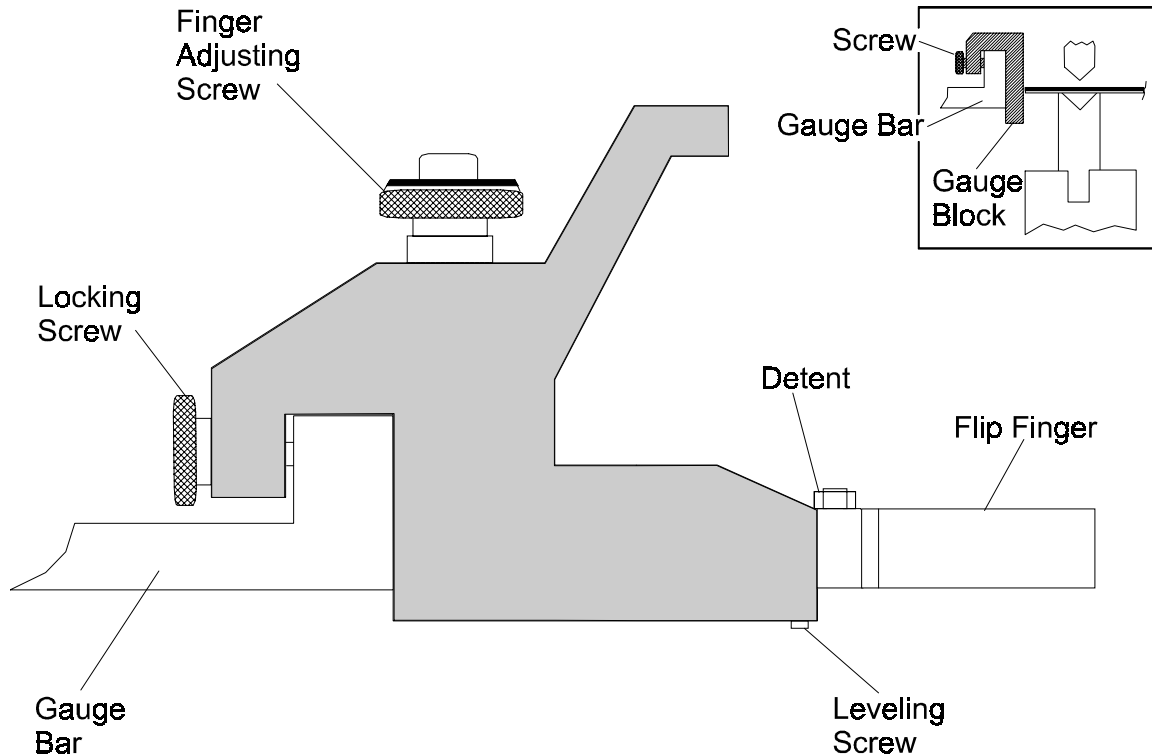

Figure 2-42. Flip Fingers and Gauge Block



### Warning

Ensure that the *carriage arrestor bars* are correctly set on the gauge(s) to prevent any part of the gauge bar, finger(s) or block(s) from contacting the tooling in an unsafe manner. All adjustments should be made from the rear of the press brake. Do not reach across the tooling or in through the bed and ram.

## Flip Fingers

Flip fingers permit closer gauge positioning to the tooling. The fingers' tilting action allows reverse bending, with the length of the reverse bend dependent on the type of part to be formed.

Fingers can be manufactured by customers to suit their individual forming needs. For the most accurate results, always reference the flip fingers prior to using them after changing the tooling setup. Refer to the "Referencing the Gauging Surface" section that follows.

Install the flip fingers at any location along the gauge bar to best suit the requirements of the part. These fingers allow approximately 0.090" of horizontal micro-adjustment for close-tolerance forming. Fingers rotate in 90° increments for narrow or wide target area selection. Each finger tilts on a leveling adjustment screw at the front bottom of the body. The locking screw at the end of the flip finger assembly is used to lock it in place along the gauge bar.

When two flip fingers are used, both must be set to the same length, as measured from the back of the body to the tip of the finger. Otherwise, the parts will not have equal flange lengths on both ends.

## Gauge Blocks

Gauge blocks provide a large target area suited for work involving large-scale parts and long flanges.

Install gauge blocks at any location along the gauge bar to best suit the requirements of the part. The locking screw at the end of the gauge block is used to lock the block in place on the gauge bar. For the most accurate results, always reference the gauge blocks prior to using them after changing the tooling setup. Refer to the "Referencing the Gauging Surface" section that follows.

## Referencing the Gauging Surface

Prior to forming parts, the gauging surface must be referenced to the forming tools. The programmed dimension is the distance from the gauging surface to the punch centerline. This centerline changes for each set of tooling.

Two *zero reference bars* are provided with each Autobend to provide a quick and controlled method of squaring the gauge bar. Each zero reference bar has a 90° “V” notch in the center and a machined edge on one end. The distance from the center of the “V” notch to the machined edge is 5" (127 mm).



### Warning

Do not use the reference bars if the rubber pad is damaged or missing. This pad is a safety feature to reduce the possibility of breakage from slight over-pressure. The pads will not prevent the bars from breaking in the event of severe over-pressure from the press brake.

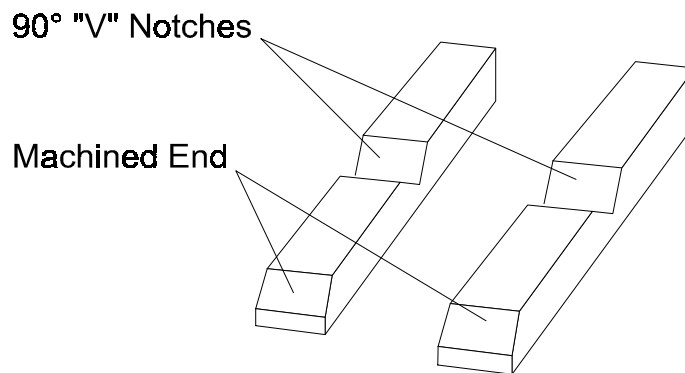

*Figure 2-43. Zero Reference bars*

Follow these instructions to reference the gauge bar:



### **Important**

For AB6 systems equipped with Ram control, the Ram On key's LED should be off indicating the control is in Standby mode.

1. Place the flip fingers or gauge blocks on the gauge bars at the extreme ends of the tooling to ensure that the gauge bar is parallel to the tooling.
2. Loosen the clamp bolts on the lower part of the vertical supports. Slightly pull back the support.
3. Loosen the carriage arrestor bars.
4. Program a single bend job with a 5" (127 mm) dimension and 0 bend allowance.

### **Note**

Refer to the "Job Programming" and "Bend Programming" sections of the *AB6 Programming and Operations* manual for more information.

5. Press the Run button.
6. Insert the zero reference bars so the machined edges face the gauging surface with the "V" notches aligning with the punch centerline.
7. Carefully jog the ram until the tooling firmly clamps the zero reference bars. Lock the ram in this position.
8. Adjust the gauge bar's height so the gauging surface is aligned with the reference bars.
9. Push the vertical supports forward so the gauging surface is flush against the zero reference bars. For the most accurate results, use a 0.002" feeler gauge to verify that the gauge surface is flush with the machined edge of the zero reference bars.
10. Lock the clamping bolts at the bottom of the vertical supports.
11. Return the ram to its open position. Remove the zero reference bars and store them in a safe place.
12. Press the console's Stop button.

13. Return the Y-Axis mode to Active.
14. Press the Ram On key.

The figure below illustrates the gauge referencing process:

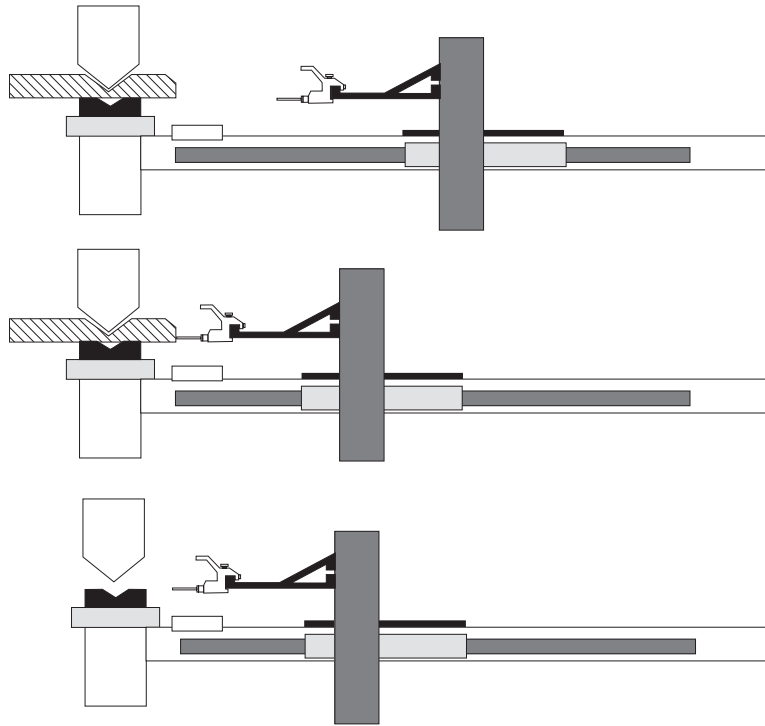

*Figure 2-44. Gauge referencing*



## Electrical Connections

Electrical connections for the AB6 are covered in this section. These connections include the advance and retract sensor. There are also cable connections between the power cabinet, control console, and gauge(s).

Two types of power cabinets are available for the AB6: the Small or Standard power cabinets which have a Main board for advance retract connections, and the Large power cabinet which contains a Relay board for advance retract connections.



### Warning

Before performing any electrical connections, become familiar with the “Electrical Safety Guidelines” in the “Introduction” chapter of this manual.

### Small or Standard Power Cabinets with Main Board

The electrical connections require stripped wires to be inserted into the J8 connector in the Main Board. The following sections refer to the Main Board J8 Connector. This removable 7-pin connector is located on the *Main board* in the AB6 Small or Standard power cabinet (see the figure below). This figure shows the Main board’s components.

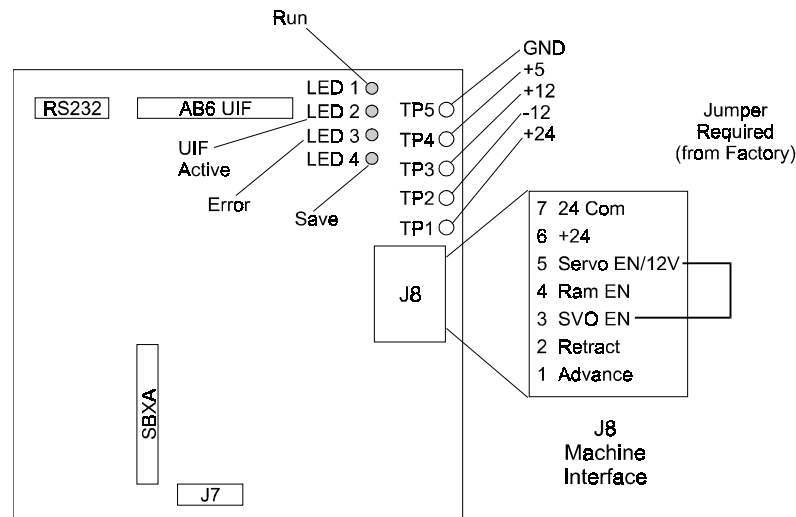
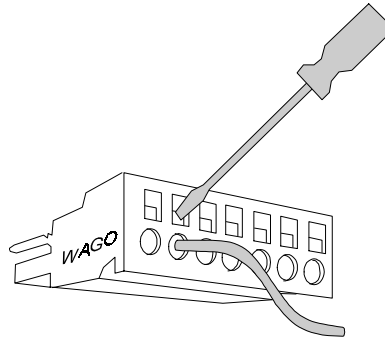

Figure 2-45. Main Board with J8 Connector

## J8 Connector

Make connections to the J8 connector as follows:

1. Remove the J8 connector from the Main board.
2. Open a terminal by inserting the blade of a small flat screwdriver into the rectangular slot above the wire connection point as shown in the figure below.
3. As the directions in the following text require, insert the stripped wire into the circular hole directly below the appropriate rectangular slot. Be sure that the jaws do not pinch the wire insulation.
4. Remove the screwdriver. Gently pull on the wires to ensure they are securely set in the connector.
5. Repeat these steps for each wire connection.



*Figure 2-46. Inserting Wires into a J8 Connector*

## Advance Connections

There are different types of connections to advance the gauge. These connections are made with a shielded cable that runs between the advance and the AB6 power cabinet.

The *advance switch* signals the gauge to advance to its next programmed station on mechanical and upacting press brakes. However, for Guifil and Adira upacting press brakes the *advance cable* is connected without using the advance switch. An external *advance relay* provides a direct connection to its upper limit switch for hydraulic press brakes.

For more specific connection information, read the press brake's instructions.

## Two-Conductor Shielded Cable

The following sections refer to a two-conductor shielded cable that connects the advance switch or relay to the AB6 power cabinet. This cable enters the bottom of the cabinet through a *cord grip conduit fitting*. Refer to the figure below for assembly of the fitting.

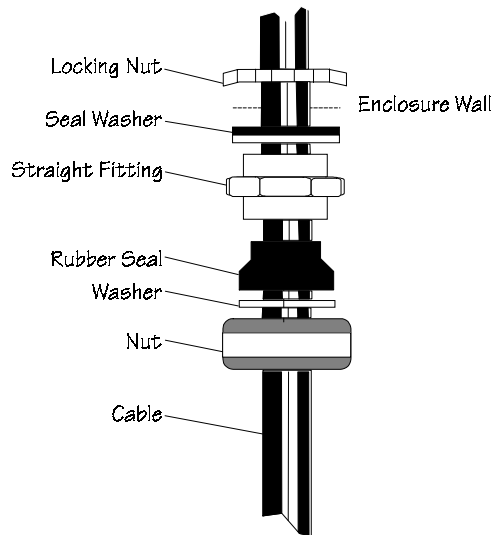

Figure 2-47. Cord Grip



### Where can we go from here?

The “Advance Switch” section contains directions for installing the advance switch on mechanical or upacting press brakes (except Adira and Guifil).

**Or...**

The “Advance Cable” section contains directions for connecting the advance cable on Guifil and Adira upacting press brakes.

**Or...**

The “Advance Relay” section contains directions for installing the advance switch on hydraulic press brakes.

## Advance Switch

Determine a suitable location for mounting the advance switch on the stationary part of the press brake's frame for either mechanical or upacting press brakes.

Locate these materials in the AB6 installation kit:

- two-conductor shielded cable
- two (2) cord-grip conduit fittings sized for the cable
- advance switch and actuator rod
- mounting screws

### Mechanical Press Brakes

Mechanical press brakes use an advance switch actuated at the top of the *ram stroke* by the *Pitman assembly* and the *rotating shaft* to signal the gauge to advance to its next programmed position.

Do not mount the switch so that any adjustable portion of the *ram* actuates it. Mounting the switch in this manner prevents having to adjust the switch every time the shut-height changes. The switch should close just before the ram reaches the top of its upward motion and open before the ram completes its downward stroke.

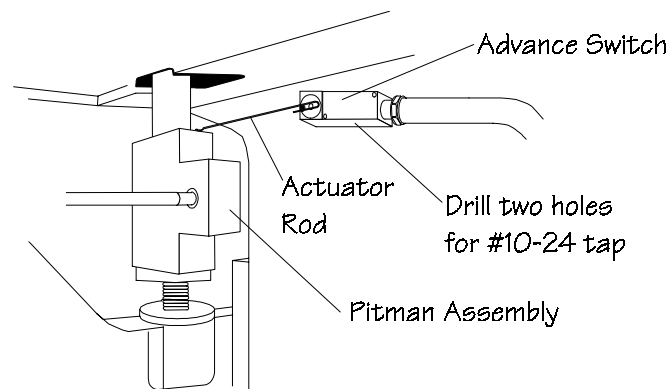

*Figure 2-48. Advance Switch Mounting for Mechanical Press Brakes*

### Upacting Press Brakes

The advance switch on upacting press brakes is actuated through the *foot treadle*. Mount the advance switch either horizontally or vertically to a stationary part of the upacting press brake's frame next to the foot treadle. The point of actuation must be in the treadle's upper mid-stroke. Place the switch as close to this point as possible.

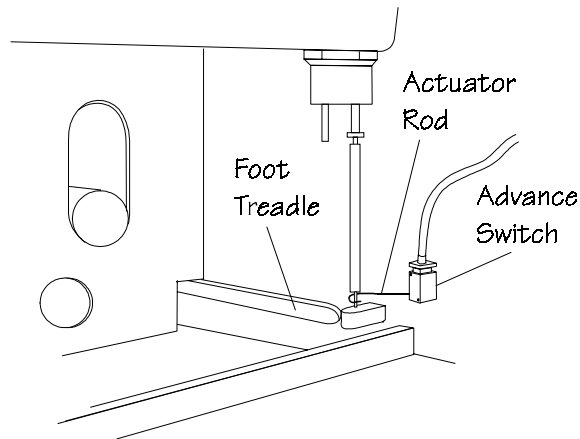

*Figure 2-49. Advance Switch on Upacting Press Brakes*

#### **Note**

The “Advance Cable” section contains directions for connecting the advance cable on Guifil and Adira upacting press brakes.

To install the advance switch on mechanical or upacting press brakes follow these instructions:



## Warning

High Voltage! To avoid potential *shock hazards*, disconnect power to the AB6 power cabinet. Failure to do so may result in serious injury.

To avoid *potential injury* turn off the press brake, and install the Out of Service tag and the lockout device.

Prevent component damage by discharging static electricity to a ground.

- Before touching, adjusting, or removing a printed circuit board (PCB), wear a wrist strap grounded to the cabinet or enclosure ground point.
- If a grounding wrist strap is not available, touch a grounded point in the enclosure each time before touching a PCB or electronic assembly. An example of a *grounding point* is the metal cabinet's screws.

Follow the procedures below:

1. Disconnect power to the press brake.
2. Remove the rear covers from the upacting press brake (not the mechanical press brake) to access its interior.
3. Position the advance switch to a clean mounting surface next to either:
  - the foot treadle on upacting press brakes, or
  - the Pitman assembly on mechanical press brakes.
4. Mark the centerline of the advance switch mounting holes. See the appropriate Advance Switch figure shown previously:  
*Advance Switch Mounting for Mechanical Press Brakes*  
*Advance Switch on Upacting Press Brakes.*
5. Drill two (2) holes with a #24 bit and tap for a #10-24 thread.

6. Remove the switch cover, and secure the switch to its mounting surface (see the figure below).

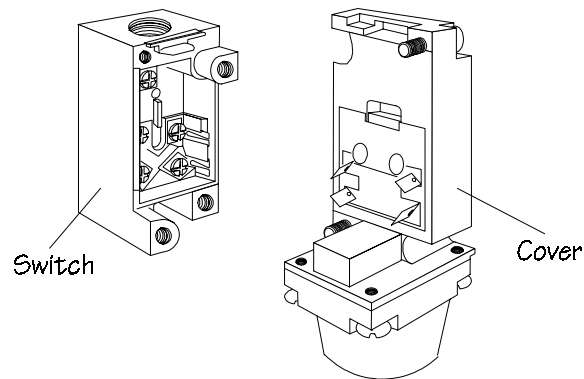

*Figure 2-50. Advance Switch with Cover Removed*

7. Mount one of the cord-grip conduit fittings to the switch. Route about 5" (127 mm) of cable through the fitting to the switch.
8. Strip back 1" (25.4 mm) of insulation and 1/4" (6 mm) on both wire ends.
9. Connect one of the stripped wires to switch Normally Open contact (terminal #3) and the other to Common contact (terminal #4).
10. Place the shielded wire under the ground terminal and tighten.
11. Refer to the instructions that come with the switch and set the internal cam lobes for upward rotation.



### **Important**

After setting the cam, close the cover and check that the rotation is correct. Reset the cam if necessary. Be sure to firmly tighten the four attaching screws.

12. Re-install the switch cover. Be sure to firmly tighten both screws.
13. Determine the appropriate actuator rod length to maintain full contact throughout the stroke.
14. Bend the rod's end to form an upward hook. Cut off the excess.

15. Adjust the switch to actuate at the top of the stroke for mechanical press brakes and at the upper mid-stroke of the foot treadle for upacting press brakes.
16. Route the other end of the cable to the AB6 power cabinet. Do not route this cable adjacent to any electrical cables.
17. Remove the 7/8" (22.22 mm) diameter knock out for the 1/2" conduit fitting at the bottom of the AB6 power cabinet.
18. Route about 10" (254 mm) of the cable through the fitting into the AB6 power cabinet.
19. Strip back 2" (51 mm) of the outer insulation.
20. Cut off the shield and dispose.
21. Strip back 1/4" (6 mm) of insulation on each of the individual wires.
22. Locate the *Main board* mounted inside the AB6 power cabinet on the left-hand side.
23. Locate and remove the J8 connector in the center lower portion of the Main board.
24. Using a small screwdriver, open position #1 (labeled ADVANCE) and insert the clear wire.
25. Open position #7 (labeled 24 COM) and insert the black wire.
26. Replace the J8 connector.



### **Important**

The “Main Board” and “J8 Connector” sections earlier in this chapter contain information about locating the connector and opening the position on it.



## Advance Cable

On Guifil and Adira upacting press brakes, it is possible to connect the *advance cable* without using the advance switch. This section contains specific directions for these cable connections.

### Note

The AB6 power cabinet connections remain the same.



### Warning

High Voltage! To avoid potential *shock hazards*, disconnect power to the AB6 power cabinet. Failure to do so may result in serious injury.

To avoid *potential injury* turn off the press brake, install the Out of Service tag, and install the lockout device.

Prevent component damage by discharging static electricity to a ground.

- Before touching, adjusting, or removing a printed circuit board (PCB), wear a wrist strap grounded to the cabinet or enclosure ground point.
- If a grounding wrist strap is not available, touch a grounded point within the enclosure each time before touching a PCB or electronic assembly. An example of a *grounding point* is the metal cabinet's screws.

Follow the procedures for the appropriate section that follows.

### Adira Upacting Press Brakes

The speed change switch signals the advance. Connect the Adira cable to the press brake's speed change switch. To install the advance cable to the Adira upacting press brake, follow these instructions:

1. Locate the speed change switch labeled FV on the side of the press brake.
2. Remove the cover from the speed change switch.

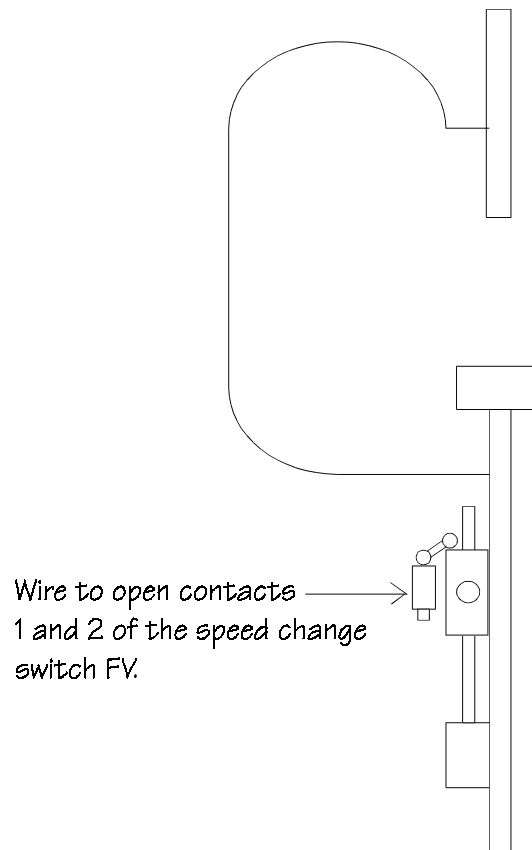

*Figure 2-51. Speed Change Switch on Left Side of Adira Press Brake*

3. Loosen the cord-grip conduit fitting.
4. Route the two-conductor cable through the fitting into the speed change switch and up to the connection points.
5. Connect to unused switch terminals #1 and #2.
6. Replace the cover on the speed change switch.



### Caution

Do not route the cable adjacent to any electrical cables.

7. Route the other end of the cable to the AB6 power cabinet. Do not route this cable adjacent to any electrical cables.
8. Remove the 7/8" (22.22 mm) diameter knock out for the 1/2" conduit fitting at the bottom of the AB6 power cabinet.
9. Route about 10" (254 mm) of the cable through the fitting into the AB6 power cabinet.
10. Strip back 2" (51 mm) of the outer insulation.
11. Cut off the shield and dispose.
12. Strip back 1/4" (6 mm) of insulation on each of the individual wires.
13. Locate the *Main board* mounted inside the AB6 power cabinet on the left-hand side.
14. Locate and remove the J8 connector in the center lower portion of the Main board.
15. Using a small screwdriver, open position #1 (labeled ADVANCE) and insert the clear wire.
16. Open position #7 (labeled 24 COM) and insert the black wire.
17. Replace the J8 connector.



### Important

The “Main Board” and “J8 Connector” sections earlier in this chapter contain information about locating the connector and opening the position on it.

Guifil Press Brakes

The speed change switch signals the advance. Connect the Guifil's cable to the press brake's terminals #8 and #11 of relay K0102 (speed change switch).

To install the advance cable to the Guifil upacting press brake, follow these instructions:

1. Open the Guifil power box and locate the connection points according to the wiring diagram below.

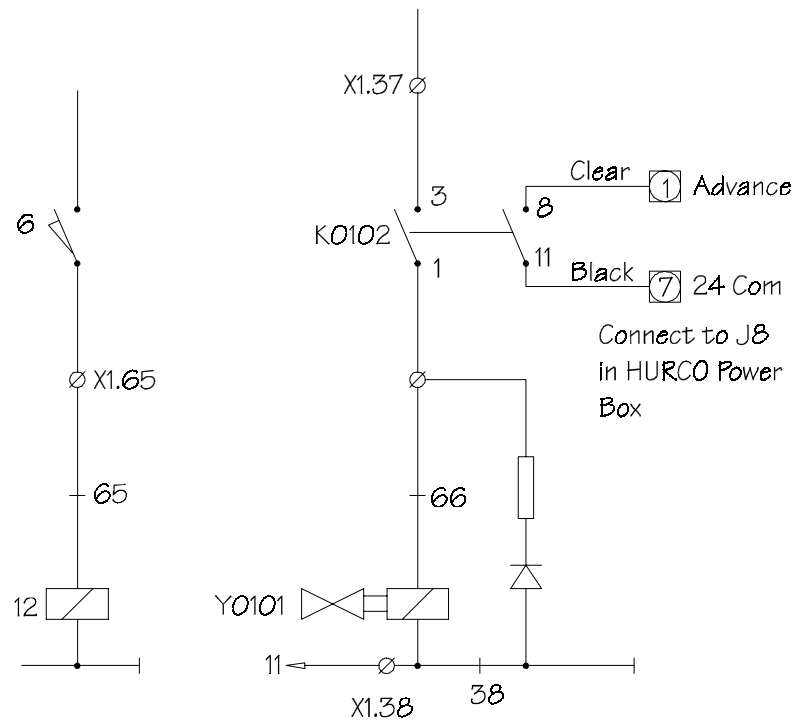

**Figure 2-52. Guifil Press Brake Wiring Diagram**

2. Install a cord-grip conduit fitting in the Guifil power box adjacent to the connection points.
3. Route the two-conductor cable through the fitting into the power box and up to the connection points.



### Caution

Do not route the cable adjacent to any electrical cables.

4. Route the other end of the cable to the AB6 power cabinet. Do not route this cable adjacent to any electrical cables.
5. Remove the 7/8" (22.22 mm) diameter knock out for the 1/2" conduit fitting at the bottom of the AB6 power cabinet.
6. Route about 10" (254 mm) of the cable through the fitting into the AB6 power cabinet.
7. Strip back 2" (51 mm) of the outer insulation.
8. Cut off the shield and dispose.
9. Strip back 1/4" (6 mm) of insulation on each of the individual wires.
10. Locate the Main board mounted inside the AB6 power cabinet on the left-hand side.
11. Locate and remove the J8 connector in the lower portion of the Main board.
12. Remove the J8 connector.
13. Using a small screwdriver, open position #1 (labeled ADVANCE) and insert the clear wire.
14. Open position #7 (labeled 24 COM) and insert the black wire.
15. Replace the J8 connector.



### Important

The “Main Board and J8 Connector” sections earlier in this chapter contain information about locating the connector and opening the position on it.

## Advance Relay - Hydraulic Press Brakes

Use a relay to advance the gauge on hydraulic and hydro-mechanical press brakes. These press brakes use electrical relays and solenoids for controlling the *ram stroke* movements.

Typically upon completion of a ram stroke, the press brake activates or deactivates an up relay. To provide an advance signal, a relay is installed inside the press brake's power cabinet. This relay is connected in parallel with the press brake's up relay.

The coil voltage of the advance relay depends on the press brake's circuit voltage. Most press brake manufacturers use the universally accepted values 120VAC and 24VDC. Hurco provides for both voltages. Refer to the press brake manufacturer's manuals to determine the correct voltage. In the event that the press brake's voltage is different, obtain a relay designed for the same voltage. For questions about obtaining a correct relay, call Hurco's Service Department for advice on how to proceed.

Locate these materials in the AB6 installation kit:

- two-conductor shielded cable
- two (2) cord-grip conduit fittings sized to the above cable
- 120VAC or 24VDC relays
- relay socket



### Warning

High Voltage! To avoid potential *shock hazards*, disconnect power to the AB6 power cabinet. Failure to do so may result in serious injury.

To avoid *potential injury* turn off the press brake, and install the Out of Service tag and the lockout device.

Prevent component damage by discharging static electricity to a ground.

- Before touching, adjusting, or removing a printed circuit board (PCB), wear a wrist strap grounded to the cabinet or enclosure ground point.
- If a grounding wrist strap is not available, touch a *grounding point* (i.e., the metal cabinet's screws) within the enclosure each time before touching a PCB or electronic assembly.

To install the advance relay on hydraulic press brakes follow these instructions:

1. Disconnect power to the press brake.
2. Examine the electrical schematics of the press brake to determine the control voltage at the ram up circuits.
3. Locate the connection points to wire the advance relay in parallel with the up relay or solenoid on the electrical schematics.
4. Locate these connection points in the press brake's power box.
5. Refer to the figures below for relay connections. The Relay Socket diagram is a track mounted, track size 1.39" (35.30 mm) Omron PTF08A-E socket. The Relay diagram is for 120 VAC and 24 VDC K10 series DPDT Potter and Brumfield relays.

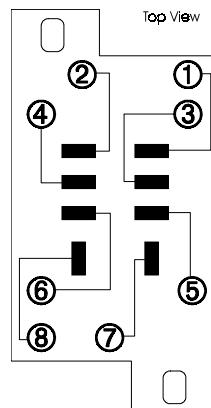

*Figure 2-53. Relay Socket Diagram*

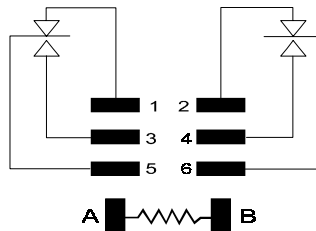

*Figure 2-54. Relay Diagram*

6. Select a relay with a coil voltage that matches the press brake's control voltage.
  - a. Mount the relay socket in the press brake's power cabinet.
  - b. Install the selected relay into the relay socket in the press brake's power cabinet.
7. Install a cord-grip conduit fitting at the bottom of the press brake's power box by punching a 7/8" (22.22 mm) hole through the power box.
8. Mount the other cord-grip conduit fitting into one of the 7/8" (22.22 mm) holes for the 1/2" (12.7 mm) conduit fitting located at the bottom of the AB6 power cabinet.



### Hint

Leave extra cable length until verifying the proper operation.

9. Route the two-conductor cable from these connection points to the relay socket coil connections.
10. Strip back the required amount of outer insulation. Do not cut off the shield.
11. Strip back 1/4" (6 mm) of insulation from the individual wires and install in the connection points of the press brake and the relay socket terminals 7 and 8 (coil). (Refer to the Relay Socket diagram on the previous page.)
12. Connect the shield to a ground lug or common point within the press brake's power box. If necessary, use a butt splice and 16- to 18-gauge stranded wire to add extra length to the shield.



### Warning

Avoid locating this cable next to the high voltage wiring.

13. Route the two-conductor cable from the relay socket through the fitting of the press brake's power box.



14. Route the two-conductor cable along the press brake's frame to the AB6 power cabinet.



**Caution**

Avoid routing this cable adjacent to any electrical cables.

15. Route the cable through the fitting and into the AB6 power cabinet.
16. Remove excess cable leaving only 10" (254 mm) of cable inside the cabinet.
17. Strip back 5" (127 mm) of outer insulation, and remove the shield.
18. Strip back 1/4" (6 mm) of insulation on both ends from the individual wires.
19. Connect the wires to the relay socket COM and N.O. connections. (Refer to the relay diagrams at the beginning of this section: the Relay Socket diagram, terminals 5 and 3, and the Relay Diagram.)
20. Locate and remove the J8 connector in the center lower portion of the Main board.
21. Using a small screwdriver, open position #1 (labeled ADVANCE) and insert one of the wires.
22. Open position #7 (labeled 24 COM) and insert the remaining wire.
23. Replace the connector into J8.

**Note**

If the relay energizes when the ram is at the bottom of its stroke, move the wire from N.O. and place in N.C. Otherwise, the gauge advances when the ram is at the bottom of its stroke instead of at the top.

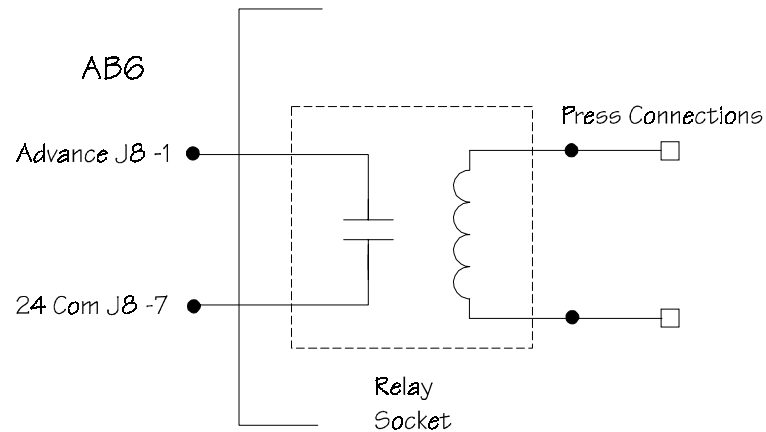

*Figure 2-55. Relay Socket Press Connections*

**Important**

The “Main Board” and “J8 Connector” sections earlier in this chapter contain information about locating the connector and opening the position on it.

## Large Power Cabinet with Relay Board

The electrical connections require stripped wires to be inserted into the TB14 connector in the Relay board. The following sections refer to the Relay Board TB14 Connector. This removable 12-pin connector is located on the *Relay board* in the Large AB6 power cabinet (see the figure below). This figure shows the Relay board's components.

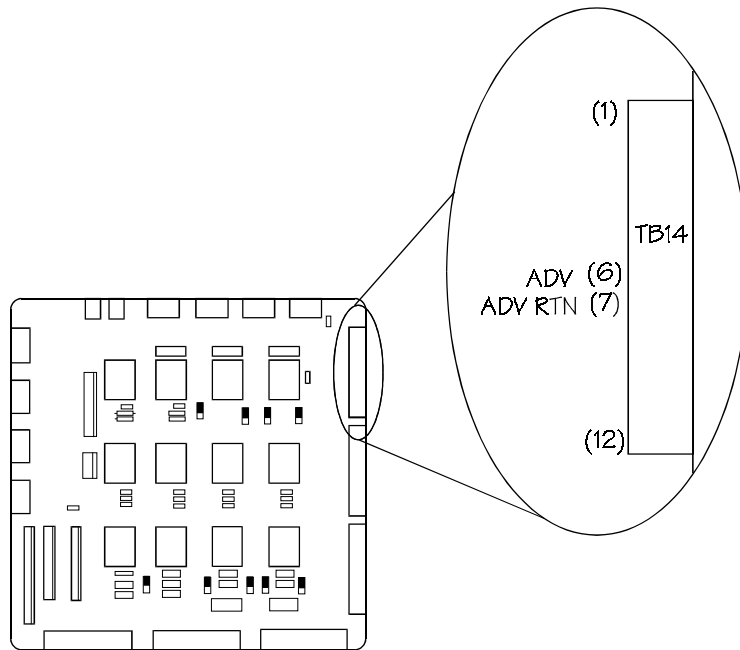
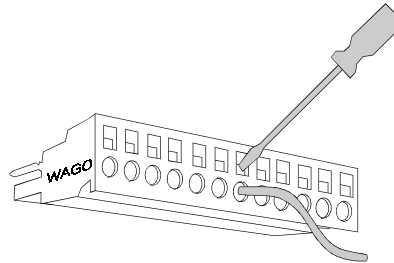

**Figure 2-56. Relay Board with TB14 Connector - Positions 6 and 7**

## TB14 Connector

Make connections to the TB14 connector as follows:

1. Remove the TB14 connector from the Relay board.
2. To open a terminal, insert the blade of a small flat screwdriver into the rectangular slot above the wire connection point as shown in the figure below.
3. As the directions in the following text require, insert the stripped wire into the circular hole directly below the appropriate rectangular slot. Be sure that the jaws do not pinch the wire insulation.
4. Remove the screwdriver. Gently pull on the wires to ensure they are securely set in the connector.
5. Repeat the previous steps for each wire connection.



*Figure 2-57. Inserting Wires into a TB14 Connector*

## Advance Connections

There are different types of connections to advance the gauge. These connections are made with a shielded cable that runs between the advance and the AB6 power cabinet.

The *advance switch* signals the gauge to advance to its next programmed station on mechanical and upacting press brakes. However, for Guifil and Adira upacting press brakes the *advance cable* is connected without using the advance switch. An external *advance relay* provides a direct connection to its upper limit switch for hydraulic press brakes.

For more specific connection information, read the press brake's instructions.

## Two-Conductor Shielded Cable

The following sections refer to a two-conductor shielded cable that connects the advance switch or relay to the AB6 power cabinet. This cable enters the bottom of the cabinet through a *cord grip conduit fitting*. Refer to the figure below for assembly of the fitting.

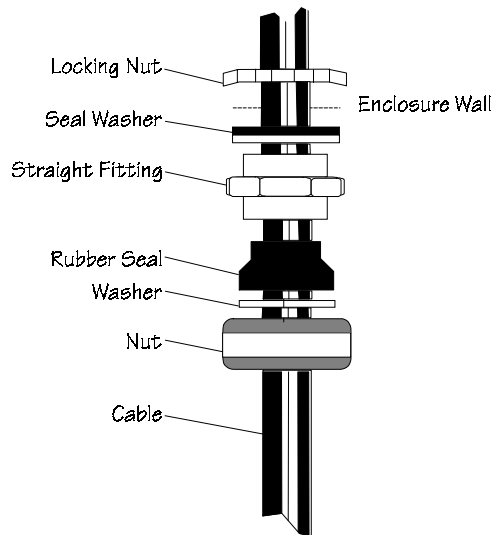

Figure 2-58. Cord Grip



### Where can we go from here?

The “Advance Switch” section contains directions for installing the advance switch on mechanical or upacting press brakes (except Adira and Guifil).

**Or...**

The “Advance Cable” section contains directions for connecting the advance cable on Guifil and Adira upacting press brakes.

**Or...**

The “Advance Relay” section contains directions for installing the advance switch on hydraulic press brakes.

## Advance Switch

Determine a suitable location for mounting the advance switch on the stationary part of the press brake's frame for either mechanical or upacting press brakes.

Locate these materials in the Standard AB6 installation kit:

- two-conductor shielded cable
- two (2) cord-grip conduit fittings sized for the cable
- advance switch and actuator rod
- mounting screws

### Mechanical Press Brakes

Mechanical press brakes use an advance switch actuated at the top of the *ram stroke* by the *Pitman assembly* and the *rotating shaft* to signal the gauge to advance to its next programmed position.

Do not mount the switch so that any adjustable portion of the *ram* actuates it. Mounting the switch in this manner prevents having to adjust the switch every time the shut-height changes. The switch should close just before the ram reaches the top of its upward motion and open before the ram completes its downward stroke.

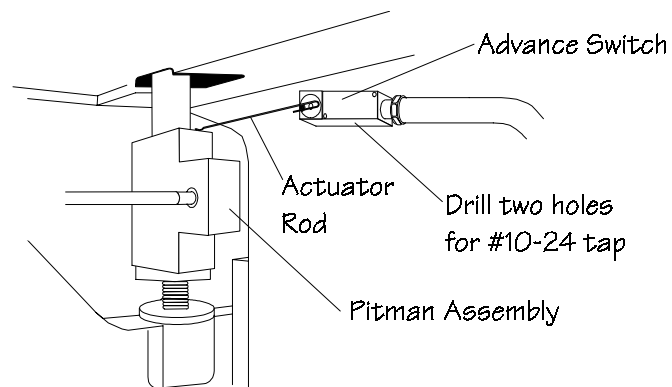

*Figure 2-59. Advance Switch Mounting for Mechanical Press Brakes*

### Upacting Press Brakes

The advance switch on upacting press brakes is actuated through the *foot treadle*. Mount the advance switch either horizontally or vertically to a stationary part of the upacting press brake's frame next to the foot treadle. The point of actuation must be in the treadle's upper mid-stroke. Place the switch as close to this point as possible.

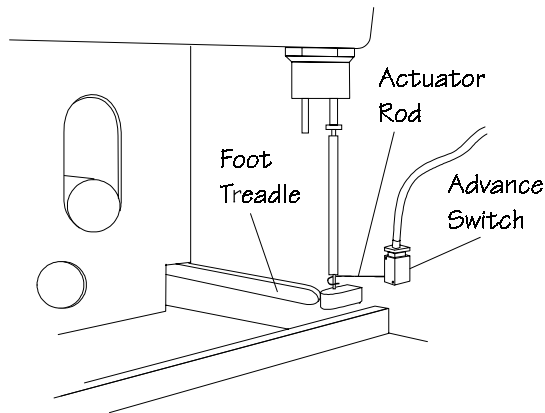

*Figure 2-60. Advance Switch on Upacting Press Brakes*

#### **Note**

The “Advance Cable” section contains directions for connecting the advance cable on Guifil and Adira upacting press brakes.

To install the advance switch on mechanical or upacting press brakes follow these instructions:



## Warning

High Voltage! To avoid potential *shock hazards*, disconnect power to the power cabinet. Failure to do so may result in serious injury.

To avoid *potential injury* turn off the press brake, and install the Out of Service tag and the lockout device.

Prevent component damage by discharging static electricity to a ground.

- Before touching, adjusting, or removing a PC board, wear a wrist strap grounded to the cabinet or enclosure ground point.
- If a grounding wrist strap is not available, touch a grounded point within the enclosure each time before touching a PCB or electronic assembly. An example of a *grounding point* is the metal cabinet's screws.

Follow the procedures below:

1. Disconnect power to the press brake.
2. Remove the rear covers from the upacting press brake (not the mechanical press brake) to access its interior.
3. Position the advance switch to a clean mounting surface next to either:
  - the foot treadle on upacting press brakes, or
  - the Pitman assembly on mechanical press brakes.
4. Mark the centerline of the advance switch mounting holes. See the appropriate Advance Switch figure shown previously:

*Advance Switch Mounting for Mechanical Press Brakes*  
*Advance Switch on Upacting Press Brakes.*
5. Drill two (2) holes with a #24 bit and tap for a #10-24 thread.



6. Remove the switch cover, and secure the switch to its mounting surface (see the figure below).

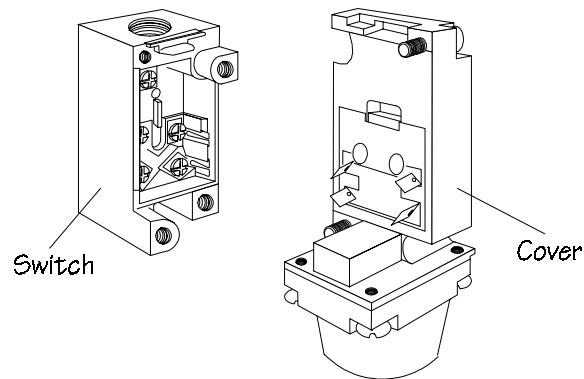

*Figure 2-61. Advance Switch with Cover Removed*

7. Mount one of the cord-grip conduit fittings to the switch. Route about 5" (127 mm) of cable through the fitting to the switch.
8. Strip back 1" (25.4 mm) of insulation and 1/4" (6 mm) on both wire ends.
9. Connect one of the stripped wires to switch Normally Open contact (terminal #3) and the other to Common contact (terminal #4).
10. Place the shielded wire under the ground terminal and tighten.
11. Refer to the instructions that come with the switch and set the internal cam lobes for upward rotation.



### **Important**

After setting the cam, close the cover and check that the rotation is correct. Reset the cam if necessary. Be sure to firmly tighten the four attaching screws.

12. Re-install the switch cover. Be sure to firmly tighten both screws.
13. Determine the appropriate actuator rod length to maintain full contact throughout the stroke.
14. Bend the rod's end to form an upward hook. Cut off the excess.

15. Adjust the switch to actuate at the top of the stroke for mechanical press brakes and at the upper mid-stroke of the foot treadle for upacting press brakes.
16. Route the other end of the cable to the Large AB6 power cabinet. Do not route this cable adjacent to any electrical cables.
17. Route about 10" (254 mm) of the cable through the fitting into the Large AB6 power cabinet.
18. Strip back 2" (51 mm) of the outer insulation.
19. Cut off the shield and dispose.
20. Strip back 1/4" (6 mm) of insulation on each of the individual wires.
21. Locate the *Relay board* mounted inside the back of the Large AB6 power cabinet.
22. Locate the TB14 connector in the upper right-hand corner of the Relay board.
23. Remove the TB14 connector.
24. Using a small screwdriver, open position #6 (labeled ADV) and insert the clear wire.
25. Open position #7 (labeled ADV RTN) and insert the black wire.
26. Replace the TB14 connector.



### **Important**

The “Relay Board” and “TB14 Connector” sections earlier in this chapter contain information about locating the connector and opening the position on it.

## Advance Cable

On Guifil and Adira upacting press brakes, it is possible to connect the *advance cable* without using the advance switch. This section contains specific directions for these cable connections.

### Note

The Large AB6 power cabinet connections remain the same.



### Warning

High Voltage! To avoid potential *shock hazards*, disconnect power to the power cabinet. Failure to do so may result in serious injury.

To avoid *potential injury* turn off the press brake, install the Out of Service tag, and install the lockout device.

Prevent component damage by discharging static electricity to a ground. Follow the procedures below:

- Before touching, adjusting, or removing a printed circuit board (PCB), wear a wrist strap grounded to the cabinet or enclosure ground point.
- If a grounding wrist strap is not available, touch a grounded point within the enclosure each time before touching a PCB or electronic assembly. An example of a *grounding point* is the metal cabinet's screws.

### Adira Upacting Press Brakes

The speed change switch signals the advance. Connect the Adira cable to the press brake's speed change switch. To install the advance cable to the Adira upacting press brake, follow these instructions:

1. Locate the speed change switch labeled FV on the side of the press brake.
2. Remove the cover from the speed change switch.

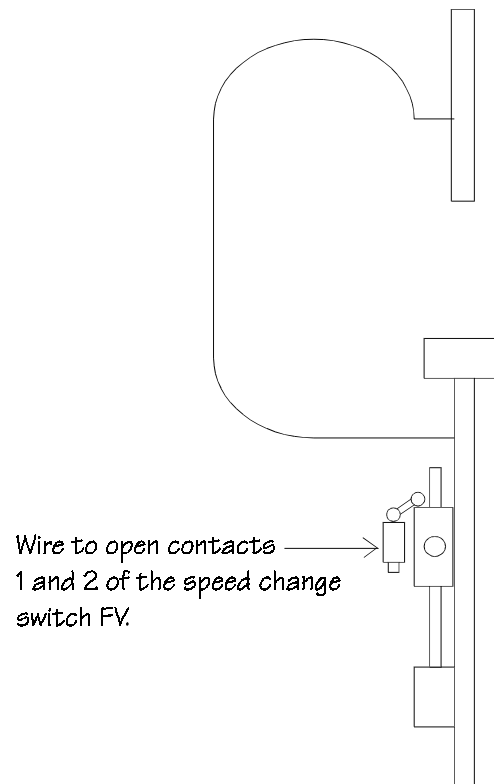

*Figure 2-62. Speed Change Switch on Left Side of Adira Press Brake*

3. Loosen the cord-grip conduit fitting.
4. Route the two-conductor cable through the fitting into the speed change switch and up to the connection points.
5. Connect to unused switch terminals #1 and #2.
6. Replace the cover on the speed change switch.



### Caution

Do not route the cable adjacent to any electrical cables.

7. Route the other end of the cable to the Large AB6 power cabinet. Do not route this cable adjacent to any electrical cables.
8. Route about 10" (254 mm) of the cable through the fitting into the Large AB6 power cabinet.
9. Strip back 2" (51 mm) of the outer insulation.
10. Cut off the shield and dispose.
11. Strip back 1/4" (6 mm) of insulation on each of the individual wires.
12. Locate the *Relay board* mounted inside the back of the Large AB6 power cabinet.
13. Locate the TB14 connector in the upper right-hand corner of the Relay board.
14. Remove the TB14 connector.
15. Using a small screwdriver, open position #6 (labeled ADV) and insert the clear wire.
16. Open position #7 (labeled ADV RTN) and insert the black wire.
17. Replace the TB14 connector.
18. Adjust the speed change switch so the advance occurs during mid-stroke.



### Important

The “Relay Board” and “TB14 Connector” sections earlier in this chapter contain information about locating the connector and opening the position on it.

Guifil Press Brakes

The speed change switch signals the advance. Connect the Guifil's cable to the press brake's terminals #8 and #11 of relay K0102 (speed change switch).

To install the advance cable to the Guifil upacting press brake, follow these instructions:

1. Open the Guifil power box and locate the connection points according to the wiring diagram below.

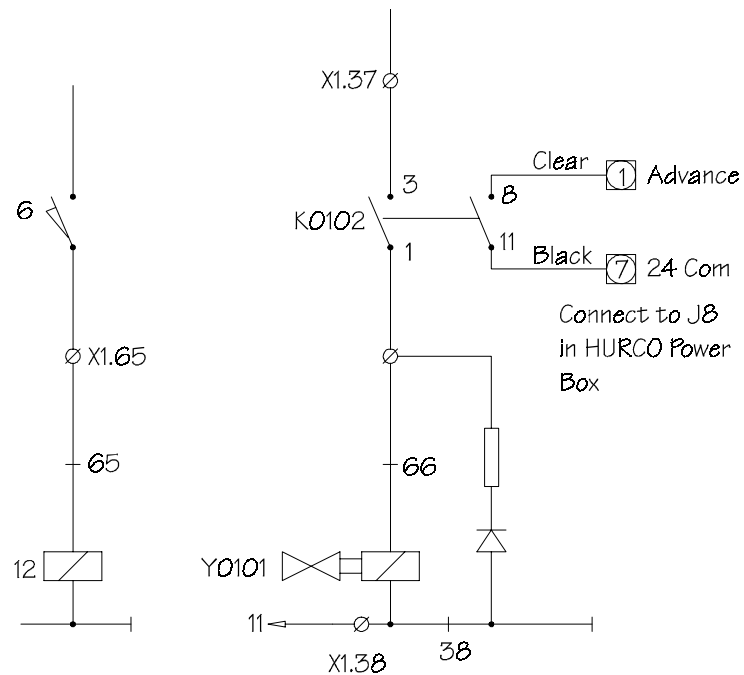

*Figure 2-63. Guifil Press Brake Wiring Diagram*

2. Install a cord-grip conduit fitting in the Guifil power box adjacent to the connection points.
3. Route the two-conductor cable through the fitting into the power box and up to the connection points.



**Caution**

Do not route the cable adjacent to any electrical cables.

4. Route the other end of the cable to the Large AB6 power cabinet. Do not route this cable adjacent to any electrical cables.
5. Route about 10" (254 mm) of the cable through the fitting into the Large AB6 power cabinet.
6. Strip back 2" (51 mm) of the outer insulation.
7. Cut off the shield and dispose.
8. Strip back 1/4" (6 mm) of insulation on each of the individual wires.
9. Locate the Relay board mounted inside the back of the Large AB6 power cabinet.
10. Locate the TB14 connector in the upper right-hand corner of the Relay board.
11. Remove the TB14 connector.
12. Using a small screwdriver, open position #6 (labeled ADV) and insert the clear wire.
13. Open position #7 (labeled ADV RTN) and insert the black wire.
14. Replace the TB14 connector.



**Important**

The “Relay Board and TB14 Connector” sections earlier in this chapter contain information about locating the connector and opening the position on it.

## Advance Relay - Hydraulic Press Brakes

Use a relay to advance the gauge on hydraulic and hydro-mechanical press brakes. These press brakes use electrical relays and solenoids for controlling the *ram stroke* movements.

Typically upon completion of a ram stroke, the press brake activates or deactivates an up relay. To provide an advance signal, a relay is installed inside the Large AB6 power cabinet. This relay is connected in parallel with the press brake's up relay.

The coil voltage of the advance relay depends on the press brake's circuit voltage. Most press brake manufacturers use the universally accepted values 120VAC and 24VDC. Hurco provides for both voltages. Refer to the press brake manufacturer's manuals to determine the correct voltage. In the event that the press brake's voltage is different, obtain a relay designed for the same voltage. For questions about obtaining a correct relay, call Hurco's Service Department for advice on how to proceed.

Locate these materials in the Standard AB6 installation kit:

- two-conductor shielded cable
- two (2) cord-grip conduit fittings sized to the above cable
- 120VAC or 24VDC relays



### Warning

High Voltage! To avoid potential *shock hazards*, disconnect power to the power cabinet. Failure to do so may result in serious injury.

To avoid *potential injury* turn off the press brake, and install the Out of Service tag and the lockout device.

Prevent component damage by discharging static electricity to a ground. Follow the procedures below:

- Before touching, adjusting, or removing a printed circuit board (PCB), wear a wrist strap grounded to the cabinet or enclosure ground point.
- If a grounding wrist strap is not available, touch a *grounding point* (i.e., the metal cabinet's screws) within the enclosure each time before touching a PCB or electronic assembly.



To install the advance relay on hydraulic press brakes follow these instructions:

1. Disconnect power to the press brake.
2. Examine the electrical schematics of the press brake to determine the control voltage at the ram up circuits.
3. Locate the connection points to wire the advance relay in parallel with the up relay or solenoid on the electrical schematics.
4. Locate these connection points in the press brake's power box.
5. Install a cord-grip conduit fitting at the bottom of the press brake's power box by punching a 1/2" (12.7 mm) hole through the power box.
6. Route the two-conductor cable through the fitting into the power box and up to the connection points.



**Hint**

Leave extra cable length until verifying the proper operation.

7. Strip back the required amount of outer insulation. Do not cut off the shield.
8. Strip back 1/4" (6 mm) of insulation from the individual wires and install in the connection points.
9. Connect the shield to a ground lug or common point within the press brake's power box. If necessary, use a butt splice and 16- to 18-gauge stranded wire to add extra length to the shield.



**Warning**

Avoid locating this cable next to the high voltage wiring.

10. Select a relay with a coil voltage that matches the press brake's control voltage.
11. Install the selected relay in the K4 socket on the *Relay board* located inside the Large AB6 power cabinet (see the Relay Board figure at the end of this section).

12. Mount the other cord-grip conduit fitting into one of the 1/2" (6 mm) holes located at the bottom of the Large AB6 power cabinet.
13. Route the two-conductor cable along the press brake frame to the Large AB6 power cabinet.



### Caution

Avoid routing this cable adjacent to any cables carrying electricity.

14. Route the cable through the fitting and into the Large AB6 power cabinet.
15. Remove excess cable leaving only 10" (254 mm) of cable inside the cabinet.
16. Strip back 5" (127 mm) of outer insulation, and remove the shield.
17. Strip back 1/4" (6 mm) of insulation from the individual wires.
18. Locate connector TB14 in the upper right-hand corner on the Relay board. Refer to the figure on the following page for the exact location of TB14.
19. Remove the TB14 connector.
20. Using a small screwdriver, open position #4 (labeled K4 Coil A in the figure on the following page) and insert one of the wires.



### Important

The "TB14 Connector" section at the beginning of this section contains instructions about opening the connection positions on the TB14 connector.

21. Open position #5 (labeled K4 Coil B) and insert the remaining wire.
22. Replace the connector into TB14.

**Note**

If the relay energizes when the ram is at the bottom of its stroke, move the jumper JP1 (see the figure below) from pins 1 and 2 and place on pins 2 and 3. Otherwise the gauge will advance when the ram is at the bottom of its stroke instead of the top.

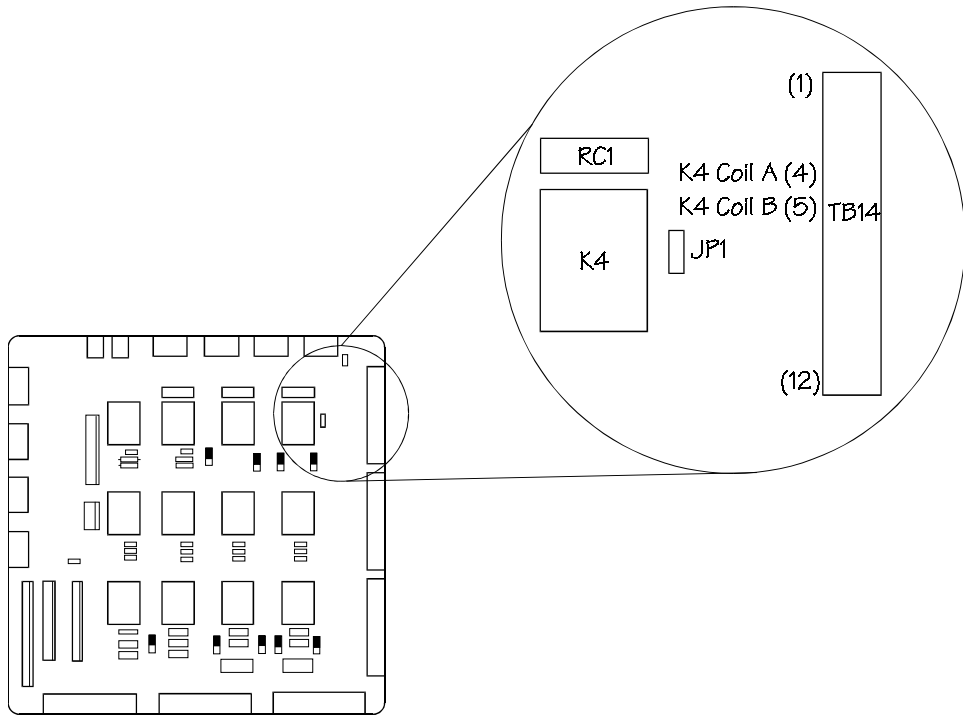

*Figure 2-64. Relay Board with TB14 Connector - K4 Coil A (4) and K4 Coil B (5)*



**Important**

The “Relay Board” and “TB14 Connector” sections earlier in this chapter contain information about locating the connector and opening the position on it.

---

## Optional Retract Sensor

The retract sensor is an option for the AB6. It signals the gauge to retract to its programmed retract dimension when the ram or bed reaches the material's pinching point position.

### Note

A retract sensor is NOT used for downacting hydraulic systems equipped with hydraulic *ram control*. The ram control measures the ram position and signals the gauge to retract when programmed. The following information does not pertain to these types of systems.

The retract sensor is mounted to the side wall of the press brake. When the sensor closes, the LED on the sensor box switches off to indicate the sensor's activation. The magnet is mounted to the press brake's ram or bed (whichever moves). As the press brake moves, the magnet passes the sensor which triggers the retract.

Locate these materials in the AB6 installation kit:

- retract sensor box
- adjustment bracket
- two (2) "L" brackets
- black magnet
- mounting hardware



### Warning

Improper retract sensor mounting may cause the gauge to retract at an inappropriate time. Gauge may run at high speed.

Keep clear of the gauge, gauge bar, and pinch points at all times.

Please read all instructions pertaining to the installation of the retract sensor prior to attempting installation. Make sure that the retract sensor and magnet will not interfere with the press brake during operation.

The figure below shows the proper placement of the retract sensor on the press brake's side wall. It is important to have 1/4" (6 mm) spacing between the magnet and the sensor during the press brake's operation.



**Caution**

To avoid damaging the retract sensor, do not allow the magnet and sensor to touch during a press cycle.

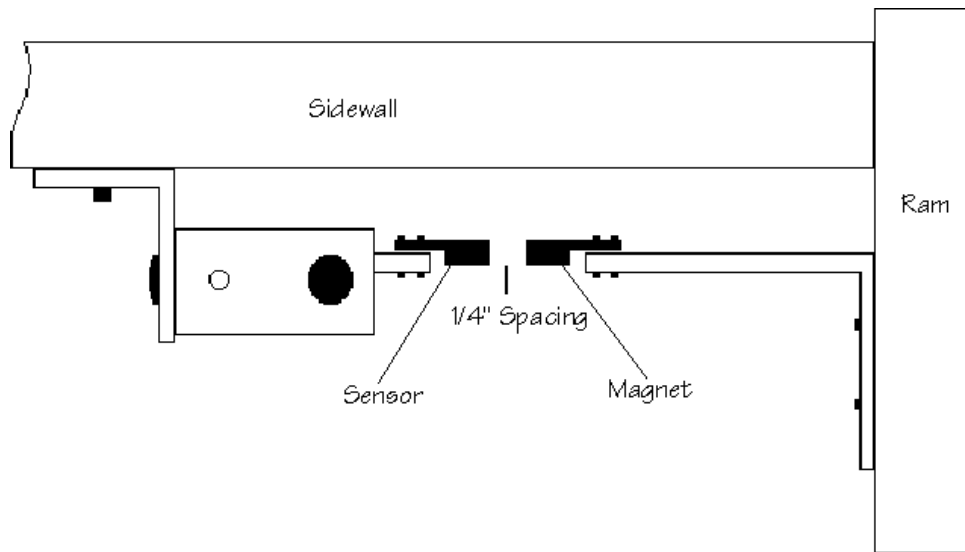

*Figure 2-65. Top View of Retract Sensor and Magnet Alignment and Spacing*

## Retract Sensor Assembly

Attach the retract sensor to the adjustment bracket with two wing nuts (see the figure below).

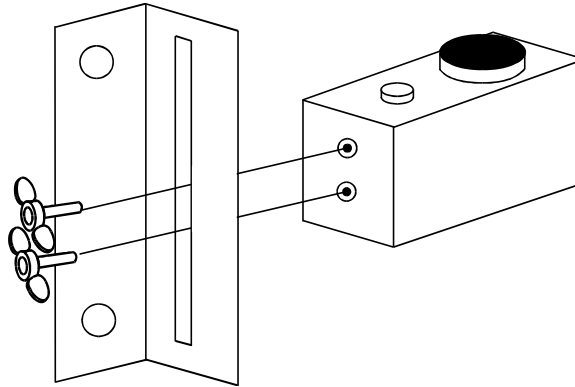
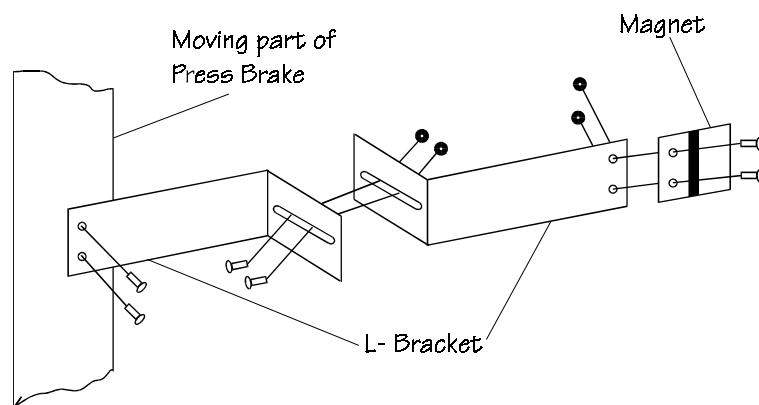

*Figure 2-66. Retract Sensor Assembly*

## Magnet Assembly

Assemble the magnet to its bracket(s) prior to attaching it to the moving part of the press brake.

1. Mount the magnet to one of the “L” brackets with screws and nuts.
2. For press brakes with the ram or bed flush with the side wall, use the two “L” brackets together to form an “S” bracket. For press brakes with the ram or bed extending beyond the side wall, use one “L” bracket.



*Figure 2-67. Magnet Assembly*

## Installing Magnet Assembly

Locate an area on the side wall of the press brake that allows mounting of the retract sensor so the magnet, when mounted on a moving element of the brake, is at pinch point for common height tooling.



### Warning

High Voltage! To avoid potential *shock hazards*, disconnect power to the AB6 power cabinet. Failure to do so may result in serious injury.

To avoid *potential injury* turn off the press brake, install the Out of Service tag, and install the lockout device.

Prevent component damage by discharging static electricity to a ground. Follow the procedures below:

- Before touching, adjusting, or removing a printed circuit board (PCB), wear a wrist strap grounded to the cabinet or enclosure ground point.
- If a grounding wrist strap is not available, touch a grounded point within the enclosure each time before touching a PCB or electronic assembly. An example of a *grounding point* is the metal cabinet's screws.

After assembling the magnet, follow these instructions to install the retract sensor:

1. Disconnect power to the press brake.
2. Hold the sensor against the side wall and the magnet assembly against the ram or bed (whichever moves).
3. Align them horizontally so there is a 1/4" (6 mm) gap between the sensor and the magnet (see the Alignment and Spacing figure).
4. Cut the brackets to fit the particular ram to which they are mounted.
5. Clean the mounting surface and secure the retract sensor.

6. Hold the magnet as a template against the ram or bed in the previously determined location. Mark the centerlines of the mounting holes.
7. Drill holes for either 8-32 or 4 mm screws.
8. Clean the mounting surface and secure the magnet in place.
9. Using the retract sensor assembly as a template, hold the sensor against the side wall in the previously determined location.
10. Mark the centerlines of the mounting holes on the adjustment bracket.
11. Drill and tap the holes for either 10-32 or 4 mm screws.
12. Route the *retract cable* from the sensor to the AB6 power cabinet.

**Caution**

Avoid routing the cable adjacent to any press brake electrical cables.

13. Install a cord-grip conduit fitting into the 1/2" (12.7 mm) hole in the bottom of the AB6 power cabinet.
14. Route the *cable* through the fitting and into the AB6 power cabinet. Remove excess cable leaving only 10" (254 mm) of cable inside the cabinet.
15. Strip back 4" (100 mm) of outer insulation and cut off the shield.
16. Strip back 1/4" (6 mm) of insulation from the individual wires.
17. Cut off shield wire.



## Small or Standard Power Cabinets

1. Using a small screwdriver, insert the blade into the slot at the top of the connector (see the AB6 J8 Connector figure at the beginning of this section).
2. Locate the connector marked J8 on the relay printed circuit board shown in the figure below.
3. Open the connection at pin 2 and insert the red wire.
4. Open the connection at pin 7 and insert the black wire.

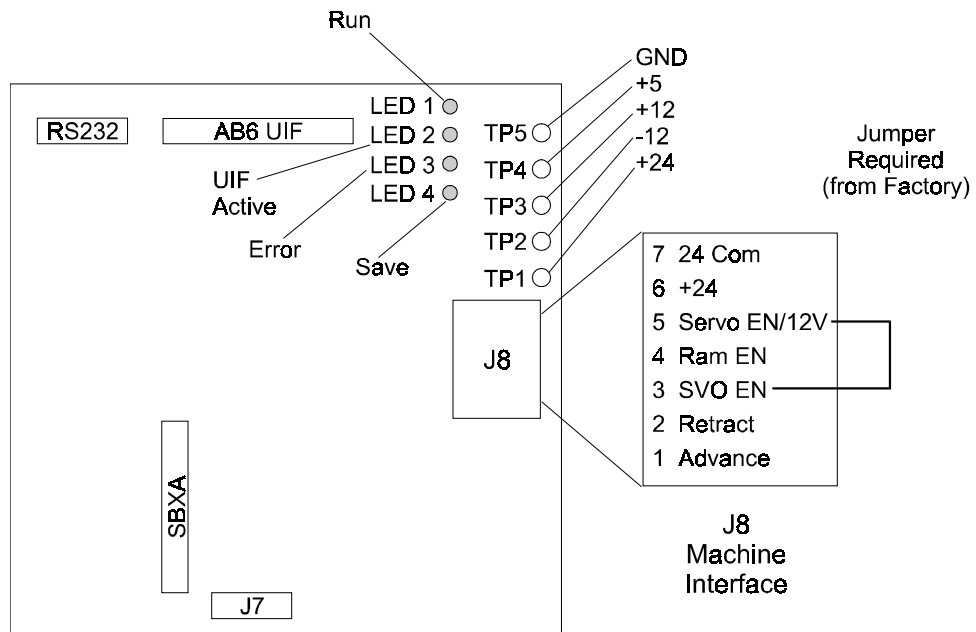
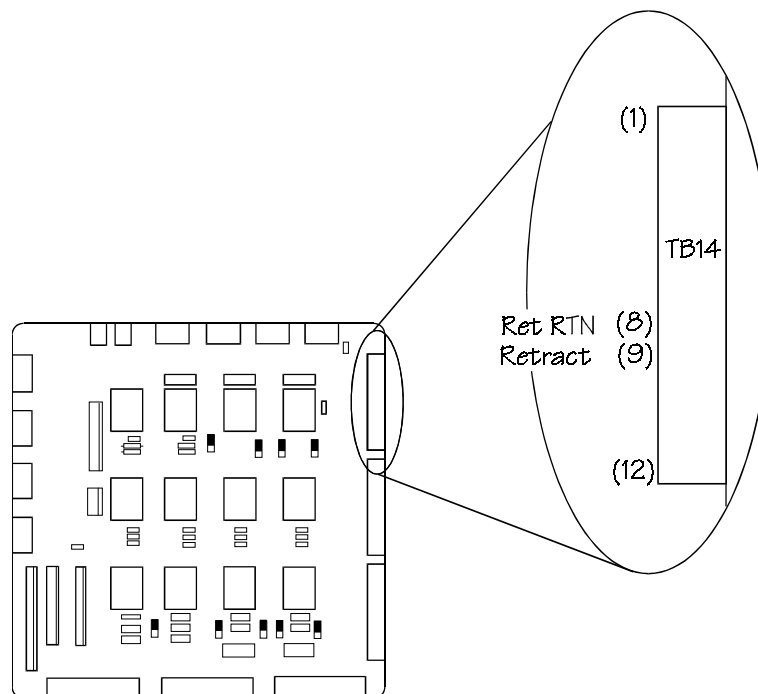

Figure 2-68. Main board with J8Connector

## Large Power Cabinet

1. Using a small screwdriver, insert the blade into the slot at the top of the connector (see the Standard AB6 TB14 Connector figure at the beginning of this section).
2. Locate the connector marked TB14 on the relay printed circuit board shown in the figure below.
3. Open the connection at pin 9 and insert the red wire.
4. Open the connection at pin 8 and insert the black wire.



*Figure 2-69. Relay Board with TB14 Connector - Positions 8 and 9*

## Advance/Pinch Retract Assembly

The advance/pinch retract is used in Europe on upacting press brakes. It signals the gauge to retract to its programmed retract dimension when the ram or bed reaches the point at which the upper tool pinches the material.

### Note

Enable Retract at Pinch with these keystrokes: Funct, 707. Set to 1. (Set to 0 to disable.)

Advance to the next station occurs when the limit switch on the advance/pinch retract is pressed and then released. Retract at pinch point occurs as soon as the switch is pressed; therefore, it is very important to adjust the cam so that a retract can only take place immediately after the material is pinched. The station will not advance until the ram is on its return stroke.

Following are directions for assembling and mounting the advance/pinch retract to a press brake.

### AB6 Limit Switch

Here is an AB6 limit switch for the advance/pinch retract assembly with its J8 and Shield connections.

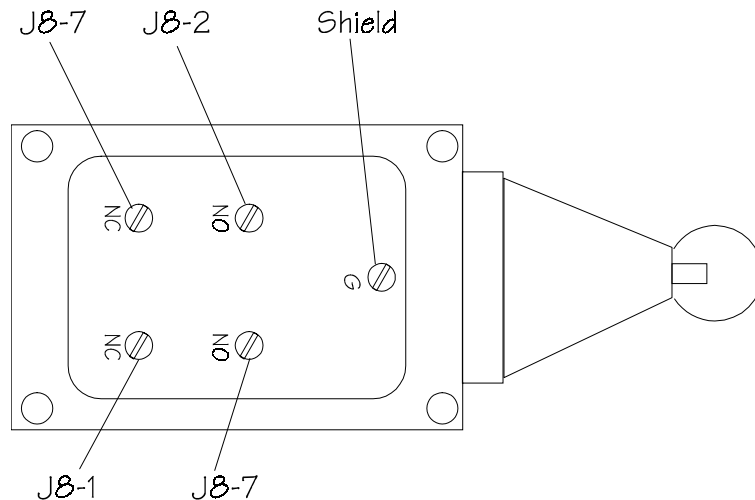

*Figure 2-70. AB6 Limit Switch*

## Installing the Assembly

To install the advance/pinch retract assembly on upacting press brakes, follow these instructions:

1. Attach the limit switch to its mounting bracket using two (2) of the M6 x 12 mm cap head screws provided.
2. Position the bracket to a fixed part of the press brake so that the adjustable actuator can activate the assembly at any point along the stroke of the press brake.
3. Mark the centerline of the bracket's holes.
4. Drill holes and attach the bracket to the press brake with three (3) of the of the M6 x 12 mm cap head screws provided.



### **Important**

The remaining four (4) M6 x 12 mm cap head screws are provided for attaching the adjustable actuator's brackets to the press brake's ram and for securing each end of the threaded rod to those brackets.

The figure below shows the switch and bracket mounted properly to the side of an upacting press brake.

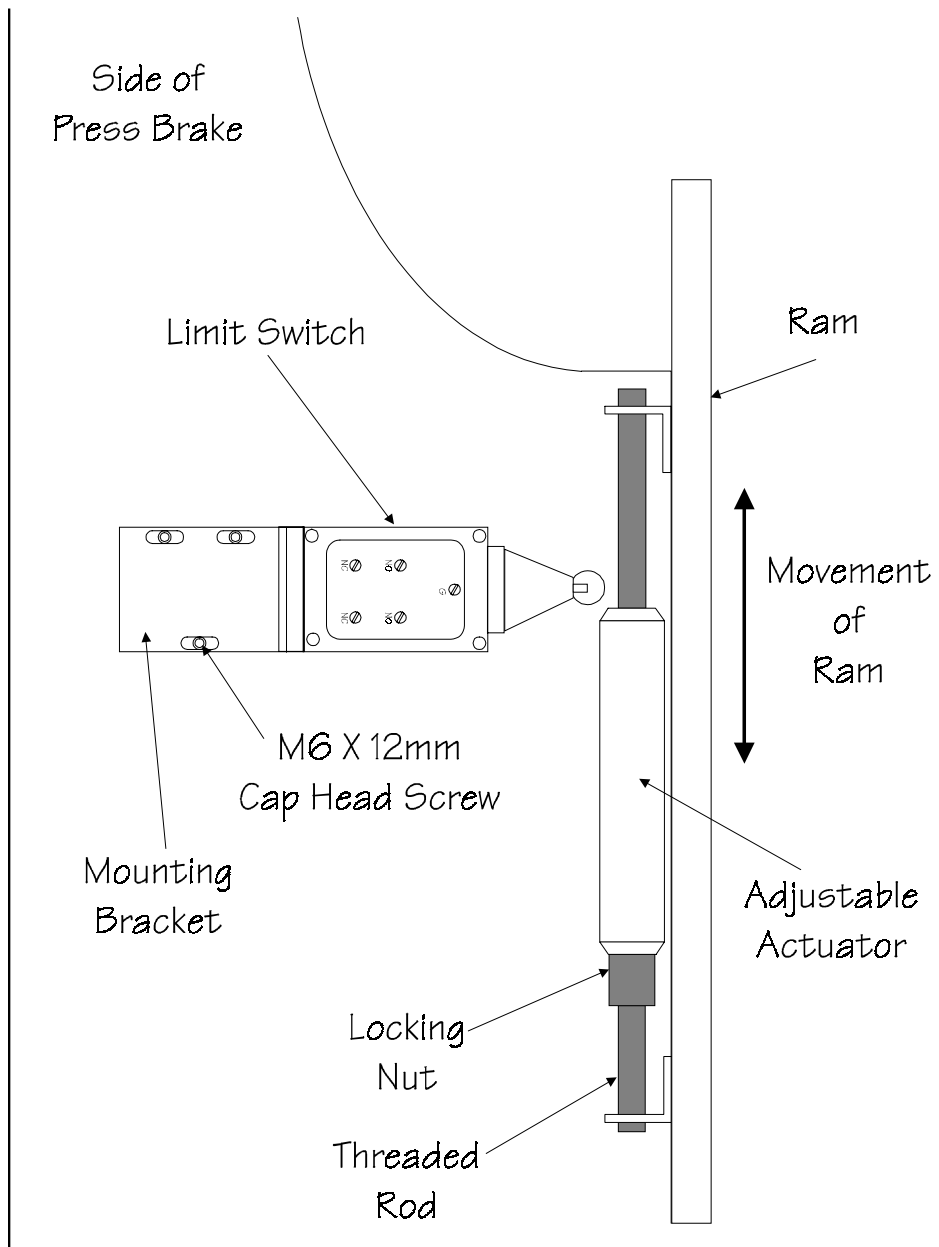

**Figure 2-71. Advance/Pinch Retract Switch Assembly**

# Connections between System Components



## Warning

Be certain to disconnect all electrical power to the press brake and the AB6 power cabinet. Do not attempt wiring with live circuits. Failure to do so may result in serious injury.

To avoid *potential injury* turn off the press brake, install the Out of Service tag, and install the lockout device.

Prevent component damage by discharging static electricity to a ground. Follow the procedures below:

- Before touching, adjusting, or removing a printed circuit board (PCB), wear a wrist strap grounded to the cabinet or enclosure ground point.
- If a grounding wrist strap is not available, touch a grounded point within the enclosure each time before touching a PCB or electronic assembly. An example of a *grounding point* is the metal cabinet's screws.

Electrical connections from the AB6 power cabinet to the control console and gauge(s) are described in the following sections. These connections are illustrated below:

Here are the AB6 component connections:

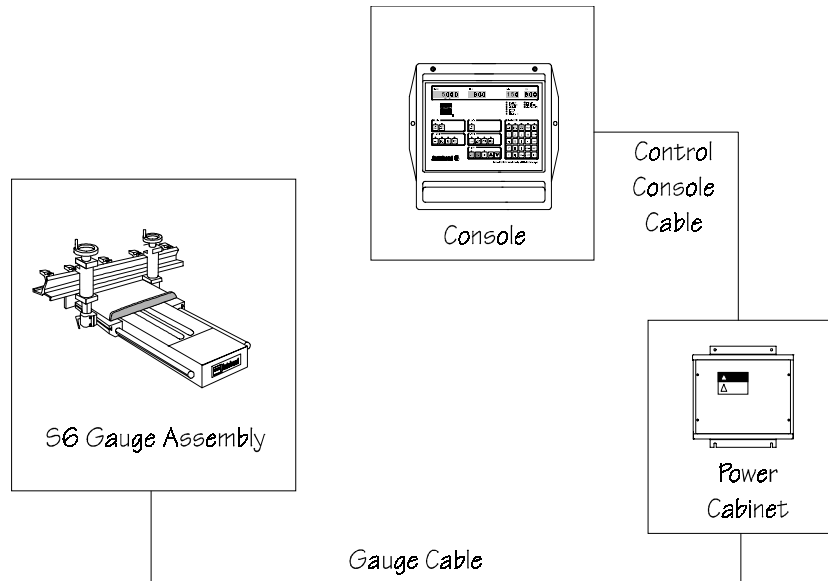

**Figure 2-72. AB6 Cable Connections**

## AB6 Control Console Cable

Follow these instructions to connect the control console to the AB6 power cabinet with an electrical cable (harness):

1. Locate the control console cable exiting from the bottom of the AB6 power cabinet.
2. Refer to the “Control Console” section at the beginning of this chapter for information about how the console is mounted to the press brake.
  - a. If the control console is mounted directly to the press brake, route the cable directly from the AB6 power cabinet to the control console.
  - b. If the control console is mounted to the press brake with the optional pendant arm, carefully route the control console cable through the pendant arm until there is enough cable to connect to the control console. Then route the cable from the end of the pendant arm into the hole in the top of the control console.
3. Unscrew the two (2) screws at the top on the front of the control console and remove the cover.
4. Connect the end of the cable to the user interface board located inside the control console on the keyboard panel. (See the figure on the following page.) Note the correct alignment of the connector key.
5. Route and secure the cable in a position where it will not be damaged.
6. Replace the cover.



The figure below illustrates the cable connection to the user interface board inside the console.



### Warning

The connector (J3) is keyed and can be connected correctly only one way. Insert the J3 connector with the single red wire on the right-hand side and the key way at the top.

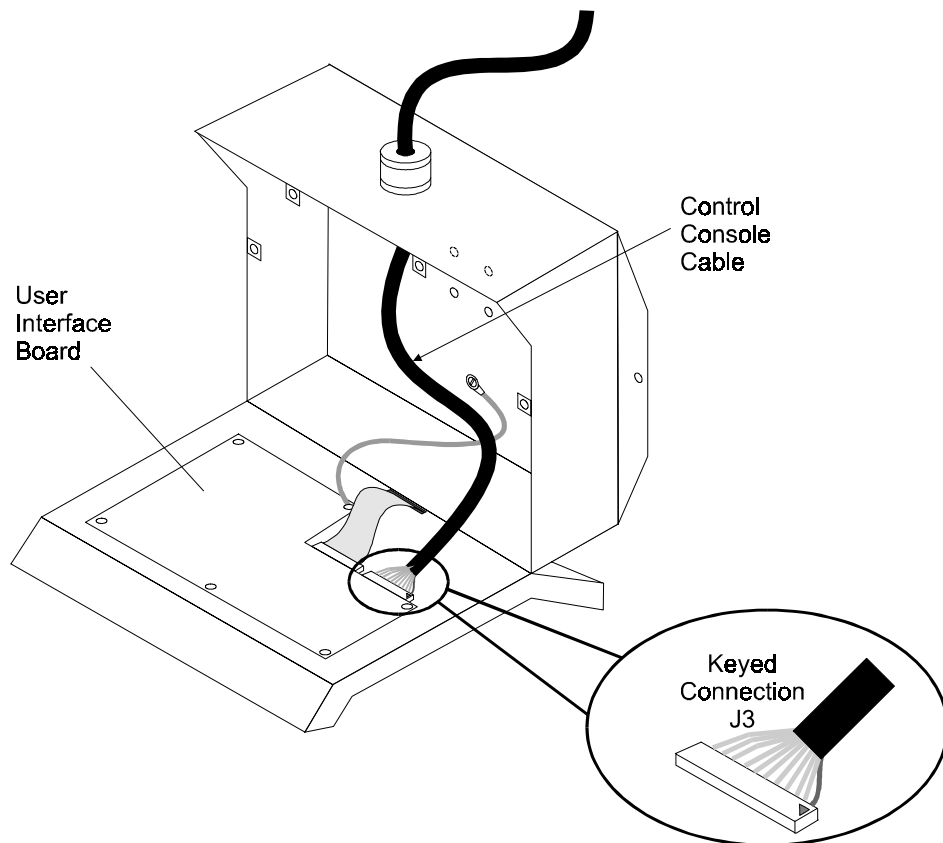

*Figure 2-73. Inside Front of AB6 Control console Showing Cable Connection*

## Gauge Cable

The gauge cable (harness) exits from the bottom of the AB6 power cabinet and connects to the gauge as described in the following sections.



### Warning

Failure to follow these guidelines may result in serious injury:

- Turn off the press brake.
- Install the Out of Service tag.
- Install the lockout device.
- Do not interchange motor and tach wiring.
- Do not reverse motor and tach positive and negative terminals as sudden gauge movement may result.

Contact Hurco's Autobend Service Department with questions regarding the *wiring* of these components.

## Installing Cable to S6 Gauge

Follow these steps to install cable to an S6 gauge:

1. Remove the gauge lock nut from the harness cord grip.
2. Thread the cable through the harness plate.
3. Re-install and tighten the lock nut.
4. Connect the two 9-pin connectors at the end of the gauge cable to their respective receptacles inside the motor housing.
5. Locate the ground wire (green with yellow stripe). Attach this wire with the self-tapping screws to the harness plate.
6. After connecting the cable, pull out any slack in the cable through the cord grip.
7. Route and secure the cable in a position where it will not be damaged.

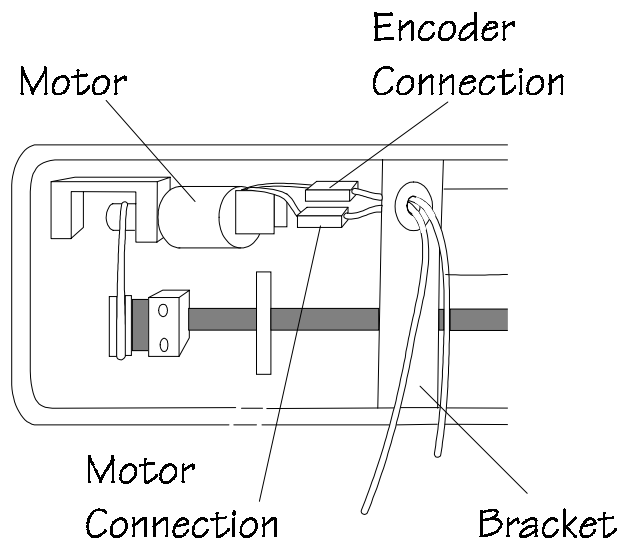
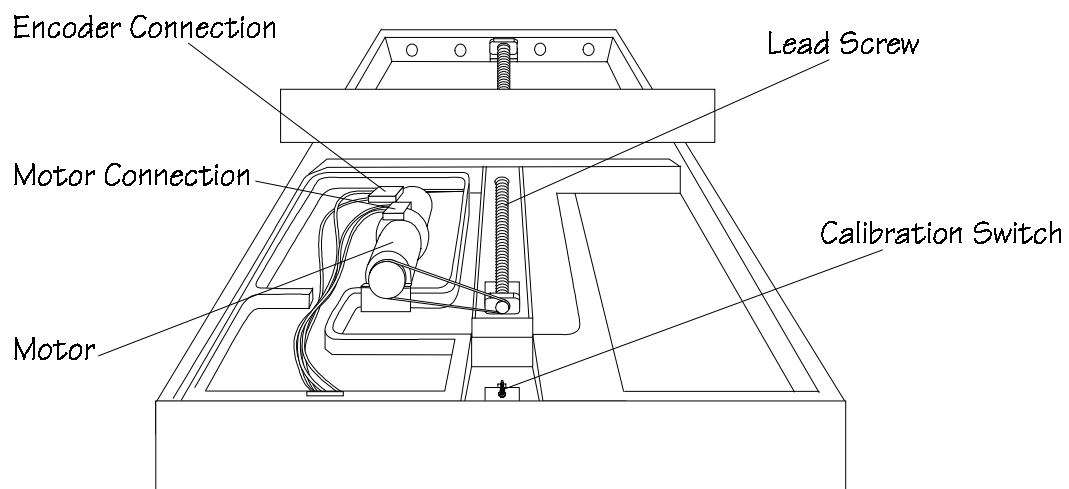

*Figure 2-74. Inside View of an S6 Gauge*

## Installing Cable to S7 Gauge

Follow these steps to install cable to an S7 gauge:

1. Remove the gauge lock nut from the harness cord grip.
2. Thread the cable through the opening in the frame at the rear left corner.
3. Re-install and tighten the lock nut.
4. Connect the two 9-pin connectors at the end of the gauge cable to their respective receptacles inside the motor housing.
5. Locate the ground wire (green with yellow stripe). Attach this wire with the self-tapping screws to the plate.
6. After connecting the cable, pull out any slack in the cable through the cord grip wire.
7. After securing the cable to the gauge, route and secure the cable in a position where it will not be damaged.
8. Install the two top covers to the frame and secure with self-tapping screws.

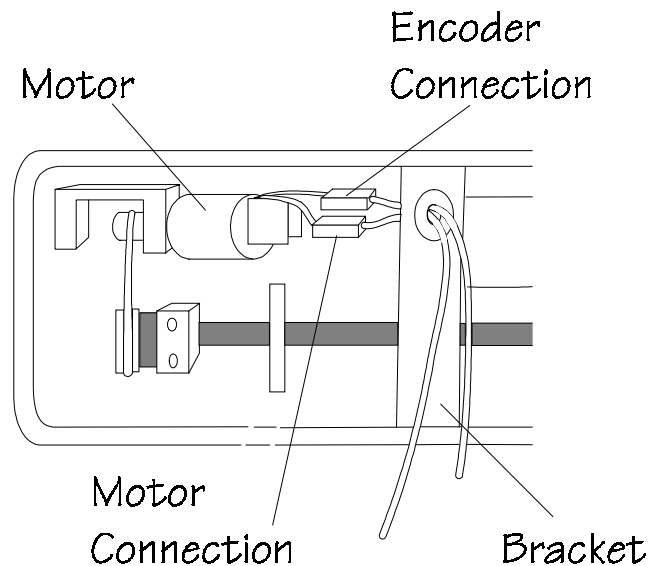

*Figure 2-75. Inside View of an S7 Gauge*

## Installing Cable to S8 Gauges

Follow these steps to install cables to S8 gauges:

1. Remove the gauge lock nut from the harness cord grip for each cable.
2. Route cables exiting from the bottom of the AB6 power cabinet to each gauge.
3. Re-install and tighten each lock nut for each gauge.
4. Repeat the following procedures for each gauge assembly:
  - a. Connect the two *9-pin connectors* at the end of the gauge cable. They connect to their respective receptacles at the motor under the gauge housing.
  - b. Locate the *ground wire* (green with yellow stripe). Attach this wire with the self-tapping screws to the harness plate.
  - c. Pull out any slack in the cable using the cord grip.
  - d. Route and secure the cable in a position where it will not be damaged.



*Figure 2-76. Inside View of an S8 Gauge*

## Installing Cable to LP Gauges

Follow these steps to install cables to LP gauges:

1. Remove the gauge lock nut from the harness cord grip for each cable.
2. Route cables exiting from the bottom of the AB6 power cabinet to each gauge.
3. Re-install and tighten each lock nut for each gauge.
4. Repeat the following procedures for each gauge assembly:
  - a. Connect the two *9-pin connectors* at the end of the gauge cable. They connect to their respective receptacles at the motor under the gauge housing.
  - b. Locate the *ground wire* (green with yellow stripe). Attach this wire with the self-tapping screws to the harness plate.
  - c. Pull out any slack in the cable using the cord grip.
  - d. Route and secure the cable in a position where it will not be damaged.

## External Power Source

Refer to the data plate affixed to the AB6 power cabinet to determine the external power requirements for the system. The power cabinet is typically factory wired to operate from either a 115 VAC ( $\pm 10\%$ ), 50/60 Hz, single phase electrical source or a 240 VAC, ( $\pm 10\%$ ), 50/60 Hz, single phase electrical source. Do not change the input voltage without also making the appropriate changes to the AB6 power cabinet wiring.

The electrical wiring must conform to all local, state or provincial codes. The external power source must be free of inductive loads that could cause noise or spikes on the line. Dedicate the external power source to the AB6, and leave it on at all times.

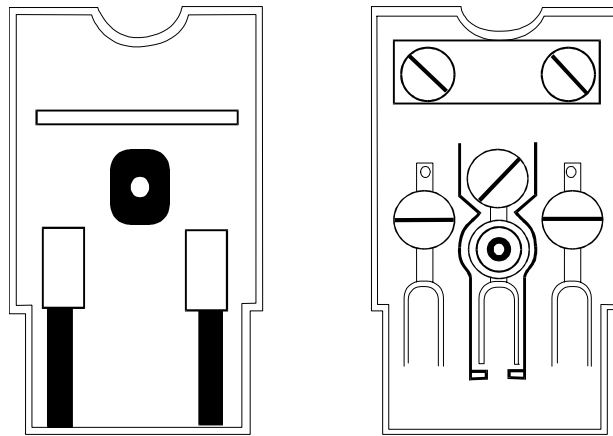

*Figure 2-77. Inside View of IEC Power Entry Plug and Cover*

Connect the external power source to the AB6 power cabinet via a 3-wire *IEC power entry plug*. Use a size 18-gauge AWG wire for the incoming power line consisting of a hot, neutral and ground wire.



### Warning

After determining the correct input electrical voltage, turn off the external power source. Failure to do so may result in serious injury.

## Connecting the Incoming Power Line to the Plug

To connect the incoming power line to the plug follow these instructions:

1. Remove the screw from the plug cover. Separate the plug into two halves.
2. Remove the two screws holding the strain relief clamp and remove the clamp.
3. Route the power line through the rubber gasket.
4. Strip back 1/8" (3 mm) of insulation from each wire.
5. Connect the neutral wire to the screw terminal with the "N" label.
6. Connect the ground wire to the screw terminal with the "E" label.
7. Connect the hot wire to the screw terminal with the "L" label.
8. Replace the clamp and tighten the two screws.
9. Replace the plug cover and tighten the screw.

## Connecting the Plug to the AB6 Power Cabinet

To connect the plug to the AB6 power cabinet follow these instructions:

1. Connect the plug into the power receptacle located on the right-hand side of the power cabinet.
2. Lock the plug in place with the clamp spring.
3. Route and secure the incoming power line where it will not be damaged.



## Changing Incoming Power Connections

If the incoming power source differs from what appears on the AB6 power cabinet's Data Plate, make appropriate changes to the AB6 power cabinet. Refer to the figures below and follow the steps as indicated.

1. Locate the IEC Power Entry Module (shown below) on the upper right-hand side of the AB6 power cabinet.

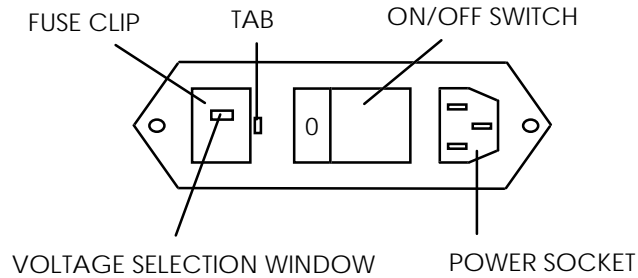

*Figure 2-78. IEC Power Entry Module*

2. Remove the fuse clip by depressing the tab located next to it. Inside the clip are two fuses and the Voltage Selector (see the figure below).

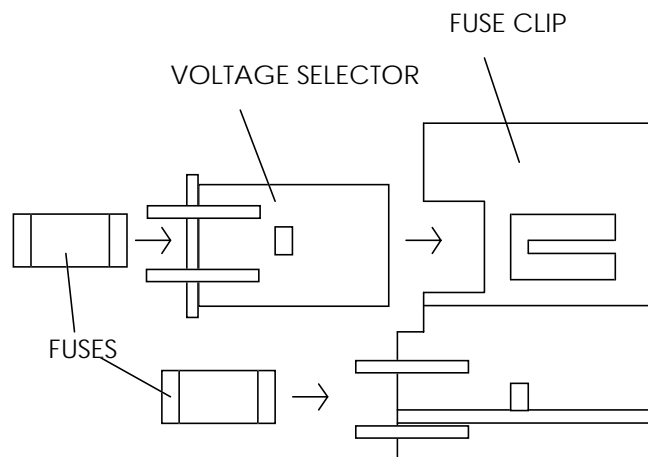

*Figure 2-79. Side View of Fuse Clip Showing Voltage Selector*

3. Set the AB6 power cabinet's voltage by rotating the selector until the correct voltage value (120 or 240) appears in the Voltage Selection Window at the top of the clip. The voltage value depends on the incoming power source.

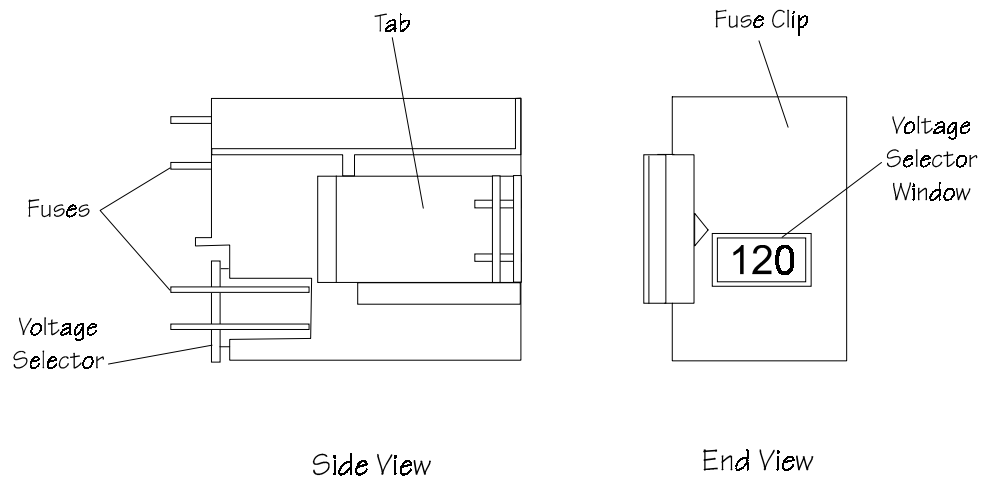

**Figure 2-80. Top View of Fuse Clip Showing Voltage Selector Window**

4. Replace the two fuses with appropriate ratings to match the power source: 120 VAC uses 8 Amps (Hurco #409-1001-235), and 240 VAC uses 4 Amps (Hurco #409-1001-234).
5. Re-install the fuse clip.

## Optional Ram Control

The second axis (ram control) controls the press brake's depth limit affecting the angle of the bend. The type of hardware used depends upon the press brake. Currently four types of hydraulic presses are eligible for second axis control:

- Upacting control
- Positive Stop Control
- Downacting Hydraulic Control
- Traveling Limit Switch Control (Komatsu)

A factory-trained Service Engineer will install the second axis and provide hands-on training. This service provides operators with the working knowledge and understanding needed to run the Hurco AB6 System confidently.

Contact Hurco after installing the items listed below and storing the unused parts:

1. Power cabinet
2. Pendant arm
3. Console head
4. Gauge assembly
5. Advance switch or relay
6. Retract sensor assembly
7. Gauge bar and support assemblies
8. Incoming power

Schedule installation and training for operating the second axis. If possible, arrange for several operators to attend the training program. Also note that misplaced parts will cause time delays and additional expenses.

---

## AB6 Installation Checklist

While installing the AB6, check each item below as it is completed:

- 1. Read all safety related information.
- 2. Disconnect the power to the press brake.
- 3. Locate an area on the press brake for mounting the AB6 power cabinet and console. Note cable (harness) lengths when these components are not mounted on the same side.
- 4. Mount the AB6 power cabinet.
- 5. Mount the AB6 console either directly to the press brake or with the optional pendant arm bracket.
- 6. Mount the console to the pendant arm.
- 7. Locate a position to mount the gauge(s) that will allow the gauge bar to be positioned to the same height as the work.
- 8. Mount the gauge(s).
- 9. Mount the vertical supports.
- 10. Mount the gauge bar.
- 11. Install the advance switch or relay.
- 12. Connect the advance wires to the advance switch (or press brake circuit). Connect the advance wires to the advance relay on hydraulic press brakes.
- 13. Connect the advance wires to the AB6 power cabinet at the main board connector J8. (Install advance relay on hydraulic press brakes.)
- 14. Install the optional retract switch (if using that option).
- 15. Connect the retract wire to the AB6 power cabinet at the main board connector J8.

- 16. Route the console cable (harness) along the side walls of the press brake to the console.
- 17. Connect the cable to the connector J3. (Note the correct alignment of the connector key.)
- 18. Route the gauge cable(s) from the AB6 power cabinet along the side walls of the press brake to the gauge(s).
- 19. Connect the gauge cables to the gauge(s). (Make sure that the cables do not interfere with the gauge movement.)
- 20. Wire the incoming power to the IEC power plug. (Note the voltage marked on the data plate.) Make sure to use a dedicated 3 wire service. Ensure a single point ground.
- 21. Using the self-tapping screws and tie wraps, secure all cables to the press brake.
- 22. Perform the system checkout:
  - a. Check to make sure area is clear.
  - b. Check for proper press brake operation.
  - c. Turn on the external power source.
  - d. Turn on the power switch located on the right side of the AB6 power cabinet. The LEDs illuminate.
  - e. For units configured for the Y-axis, press the Enter key followed by the Ram On key to change the mode to Standby Manual mode. (The Ram On LED will be off.)
  - f. Press the Jog key.
  - g. Press the Run key. The gauge(s) should calibrate.
  - h. Jog the gauge(s) forward by pressing the  $\nabla$  key. Verify that the gauge(s) moves.
  - i. Press the  $\blacktriangle$  key. Verify that the gauge(s) moves back.
- 23. Program and run a job. Refer to the “Programming and Operations” manual for details.
- 24. Contact Hurco to schedule an installation date with a factory-trained installer for the Y- axis.

# Maintenance

---

## Maintenance Schedule

For best results in keeping the Autobend in good condition, follow this maintenance schedule:

### Control

1. Clean the front panel with a mild soap detergent on a weekly basis; daily if the shop environment is dirty.
2. Every six months inspect the control harness for possible cuts in the cable insulation or wires. Replace if damaged.

### X-Axis

1. Wipe down the leadscrew and linear ways with a soft, lint-free cloth and apply a light film of S.A.E. #10 oil on a weekly basis. If the shop environment is dirty, clean them daily.
2. Every six months inspect belts, couplings, and pulleys for wear or looseness. Tighten as necessary.
3. Every six months inspect the gauge harness for possible cuts in the cable insulation or wires. Replace if damaged.

## **Y-Axis Downacting Hydraulic**

1. Every six months check the linear scale mounting bolts, linkage rod, rod mounting bolts, and bracket for looseness. Tighten as required.
2. Every three months remove the linear scale cover and wipe down the linear way with a soft, lint-free cloth. Apply a light film of lithium grease.
3. Every six months inspect the Y-axis linear scale harness for possible cuts in the cable insulation or wires. Replace if damaged.

## **Y-Axis Positive Stop**

1. Every six months inspect belts, couplings, and pulleys for wear or looseness. Tighten as necessary.
2. Every six months inspect the Y-axis harness for possible cuts in the cable insulation or wires. Replace if damaged.

## **Y-Axis Upacting**

1. Wipe down the lead screw and carriage ways with a soft, lint-free cloth. Apply a light film of S.A.E. #10 oil to the lead screw on a weekly basis; if the shop environment is dirty, clean the lead screw daily.
2. Every six months inspect belts, couplings, and pulleys for wear or looseness. Tighten as necessary.
3. Every six months inspect the Y-axis harness for possible cuts in the cable insulation or wires. Replace if damaged.

# Index

---

9-pin connector, 2-108 to 2-111

## A

Adira upacting press brake  
  speed change switch, 2-67, 2-85  
Adjustable leg assembly, 2-41  
Advance cable  
  Adira upacting p brake, 2-67, 2-85  
  Guifil upacting p brake, 2-69, 2-87  
Advance relay  
  hydraulic press brake, 2-59, 2-77  
  ram stroke, 2-71, 2-89  
  ram up circuits, 2-72, 2-90  
  solenoid, 2-72, 2-90  
  up relay, 2-72, 2-90  
  upper limit switch, 2-59, 2-77  
Advance switch  
  foot treadle, 2-62, 2-80  
  mechanical press brake, 2-59, 2-61,  
    2-63, 2-77, 2-79, 2-81  
  Pitman assembly, 2-61, 2-79  
  ram stroke, 2-61, 2-79  
  rotating shaft, 2-61, 2-79  
  upacting press brake, 2-59, 2-62,  
    2-63, 2-77, 2-80, 2-81  
Autobend power cabinet, 2-5  
  mounting to press brake, 2-5  
  safety decals, 2-4, 2-5

AWG wire, 2-112

Axis

  orientation, 1-7  
  X-axis, 1-7  
  Y-axis, 1-7

## B

Back key, 1-21  
Bend key, 1-21  
Bend,  
  most recently operated display, 1-22  
  number available, 1-22

## C

Cable, 2-97  
  control console, 2-105  
  retract, 2-97  
  runs, 2-5  
  S6 gauge installation, 2-108  
  S7 gauge installation, 2-108, 2-109  
  S8 gauge installation, 2-108 to 2-111  
  shielded cable, 2-60, 2-78  
  two-conductor shielded cable, 2-60,  
    2-78  
Calibration, 1-22  
Carriage arrestor bars, 1-12, 2-50, 2-53  
Caution tape, 1-10  
Checklist  
  installation, 1-2, 2-117  
Clear key, 1-21  
Component mounting, 1-1  
Console keys, 1-21  
Control console, 1-5, 2-7, 2-105  
  display, 1-20  
  layout, 1-20  
  maintenance schedule, 3-1  
  membrane keys, 1-21  
  Run key, 1-14  
  Stop key, 1-4, 1-14  
Control pendant arm, 2-8, 2-9, 2-105  
Cord grip conduit fitting, 2-60, 2-78

## D

Date, 1-22  
Decals  
  safety, 2-4  
Delete key, 1-21  
Die retainer plates, 2-14, 2-15  
Dimensions  
  mounting for dual gauges, 2-32  
  mounting hole, 2-18, 2-21, 2-24,  
    2-25  
  X for dual gauges, 2-29  
Dovetail slots, 2-14  
Drill bits, 2-3



## **E**

### Electrical

grounding point, 1-17, 2-63, 2-66,  
2-81, 2-84, 2-96, 2-103

printed circuit boards, 1-17

static, 1-17

systems, 1-15

### Electrical connections, 1-2, 2-58

9-pin connectors, 2-108 to 2-111

AB6 power cabinet, 2-112

AWG wire, 2-112

cable runs, 2-5

control console

    cable, 2-105

    harness, 2-105

control pendant arm, 2-105

external power source, 2-112

gauge cable, 2-107

gauge harness, 2-107

IEC power entry plug, 2-112, 2-114

incoming power connections, 2-114

J3 connector, 2-106

J8, 2-59, 2-65, 2-68, 2-70, 2-74, 2-98

main bd, 2-58, 2-65, 2-67, 2-68, 2-70

motor/tach/encoder wiring, 2-107

pwr cabinet, 2-58, 2-60, 2-76,

2-78, 2-107

press brake, 2-59, 2-77, 2-96

relay board, 2-76, 2-83, 2-85 to 2-88,

2-90, 2-91, 2-99

system component part, 2-104

TB14, 2-77, 2-83, 2-86, 2-88, 2-91,

2-99

### Electrical schematics

solenoid, 2-72, 2-90

up relay, 2-72, 2-90

### Emergency situation

Stop key, 1-4

Emergency Stop button, 1-14

Emergency stop circuits, 1-12

Enter key, 1-21

External power source, 2-112

## **F**

Fire hazards, 1-18

Fixturing, 1-13

    safety, 1-13

Flip fingers, 1-12, 2-45, 2-54

Foot treadle, 2-62, 2-80

Foreseeable misuse, 1-3

    from operator error, 1-3

    machine modification, 1-8

    tampering with safety devices, 1-9

    unattended operation, 1-14

Funct key, 1-21

Fuse clip, 2-114

## **G**

### Gauge

attaching to press brake, 2-38

blocks, 2-54

mounting plate, 2-14

### Gauge bar

length, 1-6

LP11, 2-45, 2-49

LP21, 2-45

LP22, 2-45, 2-49

referencing, 2-56

tilting, 2-45, 2-47

Y-shaped rigid, 2-45

Gauge cable, 2-36, 2-107

    installation, 2-108 to 2-111

Gauge harness, 2-36, 2-107

    installation, 2-108 to 2-111

Gauge height, 2-17

Gauge mounting, 2-16

Gauges, types, 1-6, 2-11

### Gauging surface

flip fingers, 2-54

gauge blocks, 2-54

referencing, 2-55

selecting, 2-53

zero reference bars, 2-55

Ground wire, 2-108 to 2-111

Guifil upacting press brake

    speed change switch, 2-69, 2-87

    wiring diagram, 2-69, 2-87

**H**

- Harness
  - control console, 2-105
- Horizontal adjustment, 1-6
- Hydraulic press brake
  - advance relay, 2-59, 2-77
  - upper limit switch, 2-59, 2-77

**I**

- IEC power entry plug, 2-112, 2-114
  - fuse clip, 2-114
  - voltage selection window, 2-115
  - voltage selector, 2-114
- IN/MM key, 1-21
- Incoming power connections, 2-114
- Insert key, 1-21
- Installation, 1-1
  - basic steps, 2-12
  - cable
    - S6 gauge, 2-108
    - S7 gauge, 2-108, 2-109
    - S8 gauge, 2-108 to 2-111
  - carriage arrestor bars, 2-50
  - checklist, 2-117
  - control pendant arm, 2-8, 2-9
    - mounting plate, 2-9
  - drill bits, 2-3
  - gauges, 2-11
  - magnet, 2-96
  - mounting variations, 2-2
  - optional ram control, 2-116
  - power cabinet, 2-5
    - mounting position, 2-6
  - preparation for, 2-1
  - retract sensor, 2-96
  - safety decals, 2-4, 2-5
  - tap sizes, 2-3
  - tilting gauge bar, 2-47
  - tools required, 2-1, 2-3
  - vertical S8 gauges, 2-35
  - vertical supports, 2-42
  - Y-shaped rigid gauge bar, 2-45

**J**

- J3 connector, 2-106
- J8 connector, 2-59, 2-65, 2-68, 2-70, 2-74, 2-98
- Job key, 1-21
- Job
  - most recently operated display, 1-22
  - number available, 1-22

**L**

- Large power cabinet, 2-76
- Leg assembly, adjustable, 2-41
- Limit switches, 1-13
- LP11 gauge
  - gauge bar, 2-49
  - mounting hole dimensions (hydraulic/mechanical or upacting press brakes), 2-24
  - vertical supports, 2-44
- LP21 gauge
  - gauge bar, 2-49
  - mounting dimensions (hydraulic/mechanical or upacting press brakes), 2-28
  - vertical supports, 2-44
- X dimension table (hydraulic/mechanical press brake), 2-31
  - vertical supports, 2-44
- LP22 and LP22/54 gauge
  - X dimension table (hydraulic/mechanical press brake), 2-31
- LP22 gauge
  - gauge bar, 2-49
  - mounting dimensions (hydraulic/mechanical or upacting press brakes), 2-28
  - vertical supports, 2-44
- LP22/54 gauge
  - adjustable leg assembly, 2-41

**M**

Magnet, 2-94, 2-95  
Main board, 2-58, 2-65, 2-67, 2-68, 2-70  
Maintenance procedures, 2-12  
Maintenance schedule, 3-1  
    control console, 3-1  
    X-axis, 3-1  
    Y-axis, 3-2  
Minus - key, 1-21  
Motor/Tach/Encoder wiring, 2-107  
Mounting device  
    vertical supports, 2-42, 2-45 to 2-47

**N**

New Bend key, 1-21  
Next key, 1-21  
Number keys, 1-21

**O**

Operator, 1-11  
    appropriate apparel, 1-11  
    error, 1-3  
    personal care, 1-11  
    qualifications, 1-3  
    training, 1-11  
Optional ram control  
    press brake, 2-116  
    second axis, 2-116

**P**

Part bending  
    safety, 1-14  
Parts list, 2-61, 2-71, 2-79, 2-89, 2-93  
Pitman assembly, 2-61, 2-79  
Plus **+** key, 1-21  
Power cabinet, 1-5  
    mounting position on press brake,  
    2-6  
Power connection, 1-15  
Power-up, 1-22  
Press brake, 1-5  
    pwr cabinet mounting position, 2-6  
    downacting hydraulic  
    optional ram control, 2-116  
Press brake (continued)

electrical connections, 2-96  
electro-mechanical failures, 1-15  
emergency stop circuits, 1-12  
foreseeable misuse, 1-3  
hydraulic  
    advance relay, 2-59, 2-77  
Komatsu  
    optional ram control, 2-116  
mechanical  
    advance switch, 2-59, 2-77  
mounting Autobend power cabinet,  
    2-5  
optional ram control, 2-116  
    positive stop control, 2-116  
owner responsibilities, 1-8  
retract sensor, 2-94  
unattended operation, 1-14  
upacting  
    advance switch, 2-59, 2-77  
    optional ram control, 2-116

**R**

Ram  
    block for shut-down, 1-23  
    control, 2-93  
    stroke, 2-61, 2-71, 2-79, 2-89  
Ram On key, 1-21  
Ram up circuits, 2-72, 2-90  
Referencing  
    gauge bar, 2-56  
    gauging surface, 2-55  
    zero reference bars, 2-55  
Relay board, 2-76, 2-83, 2-85 to 2-88,  
    2-90, 2-91, 2-99  
Relay connections, 2-72  
Relay socket press connections diagram,  
    2-75  
Retract cable, 2-97  
Retract sensor, 2-93 to 2-95  
    ram control, 2-93  
Rotating shaft, 2-61, 2-79  
Run key, 1-14

**S**

- S6 gauge
  - cable installation, 2-108
  - carriage arrestor bar, 2-50
  - mounting hole dimensions, 2-18
  - vertical supports, 2-43
- S7 gauge
  - cable installation, 2-108, 2-109
  - die retainer plates, 2-15
  - Komatsu mounting plate, 2-22
  - mounting hole dimensions, 2-21
  - vertical supports, 2-43
- S8 gauge
  - cable installation, 2-108 to 2-111
  - carriage arrestor bar, 2-50
  - mounting dimensions
    - (hydraulic/mechanical and upacting press brakes), 2-32
  - mounting dimensions (Komatsu press brakes), 2-33
  - mounting hole dimensions, 2-25
  - vertical supports, 2-43
  - X dimension table
    - hydraulic/mechanical press brake, 2-29
    - Komatsu press brake, 2-30
- S8 gauge, vertical, 2-35
- Safety, 1-3
  - additional sources, 1-18
  - Autobend system, 1-3
  - carriage arrestor bars, 1-12, 2-50
  - emergency stop circuits, 1-12
  - external power source, 1-13
  - fire prevention, 1-8, 1-18
  - fixturing, 1-13
  - gauge bar, 1-12
  - gauging fingers, 1-12
  - glasses, 1-11
  - ground wire, 2-108 to 2-111
  - grounding point, 1-17, 2-63, 2-66, 2-81, 2-84, 2-96, 2-103
  - hardware/software, 1-9
  - limit switches, 1-13
  - operator training, 1-11
- Safety (continued)
  - owner responsibilities, 1-8
  - potential injury, 2-63, 2-66, 2-71, 2-81, 2-84, 2-89, 2-96, 2-103
  - press brake, 1-12
  - printed circuit boards, 1-17
  - proper apparel, 1-11
  - ram, 1-12
  - shock hazards, 2-63, 2-66, 2-71, 2-81, 2-84, 2-89, 2-96
  - sign, 1-10, 2-5
  - static, 1-17
  - subsystem failure, 1-15
  - travel limits, 1-13
  - while operating press brake, 1-14
  - while running program, 1-14
- Safety decals, 1-10, 1-11, 2-4
  - caution tape, 1-10
  - warning sign, 1-10
- Second axis
  - optional ram control, 2-116
- Service
  - advance relay, 2-71, 2-89
  - component wiring, 2-107
  - department, 1-19
  - gauge performance, 1-19
  - lack of power, 1-19
  - optional ram control installation, 2-116
  - preparation for call, 1-19, 2-4
  - screen errors, 1-19
- Servos, disable, 1-23
- Shut-down
  - block ram, 1-23
- Small power cabinet, 2-58
- Software version number, 1-22
- Solenoid, 2-72, 2-90
- Standard power cabinet, 2-58
- Start-up, 1-22
- Steel wear plates, 2-47
- Stop key, 1-14
- Support pins, 2-14

**T**

- Tap sizes, 2-3
- TB14 connector, 2-77, 2-83, 2-86, 2-88, 2-91
- TB14 connector, 2-99
- Terminal, opening on J8 connector, 2-59
- Tilting gauge bar, 2-45, 2-47
- Two-conductor shielded cable, 2-60, 2-78

**U**

- Unattended operation, 1-14
- Up relay, 2-72, 2-90
- Upper limit switch
  - hydraulic press brake, 2-59, 2-77

**V**

- Vertical S8 gauges, 2-35
- Vertical supports, 2-42, 2-45, 2-47, 2-56
  - LP11, LP21, LP22, 2-44
  - S6, S7, S8, 2-43
- Voltage selection window, 2-115
- Voltage selector, 2-114

**W**

- Warning sign, 1-10
  - warning decal, 2-5

**X**

- X-axis, 1-7
  - maintenance schedule, 3-1

**Y**

- Y-axis, 1-7
  - maintenance schedule, 3-2
- Y-axis positive stop
  - maintenance schedule, 3-2
- Y-axis upacting
  - maintenance schedule, 3-2
- Y-shaped rigid gauge bar, 2-45

**Z**

- Zero reference bars, 2-55