



**JET**®

**METALWORKING**

**EMPOWERING SHOP PERFORMANCE**

[JETTOOLS.COM](http://JETTOOLS.COM)



**SPARKS FLY ILLUMINATING THE SHOP FLOOR...THE SOUND OF GRINDING METAL SAYS, "YOU ARE HOME". IT'S FULL POWER ALL THE TIME OR NOTHING. TO MEET YOUR PASSION FOR SHAPING, SHEARING AND TRANSFORMING METAL FROM A NON-DESCRIPT HUNK INTO SOMETHING OF REAL VALUE YOU TURN TO THE NAME INDUSTRY EXPERTS TRUST...JET.**

JET takes pride in providing you with the best in Metalworking Machinery. We know you take pride in what leaves your shop. Rugged-built to withstand the vibration and pounding of constant use, JET Metalworking Machines deliver precision results time after time. Nothing compares to the feeling of pride you get looking across your shop floor with nothing but JET as far as the eye can see. Every operation of your production line can be trusted to JET Metalworking. Reliable, quality engineering and manufacturing goes into each and every JET machine. Machinists find JET easy to use, easy to maneuver and safe to operate with a full line of accessories which give you the flexibility to create without limits.

Your JET-equipped shop is backed by one of the industry's most comprehensive warranties and unmatched levels of After-Sale service. While our machines are built to last, you can rely on JET to answer the call in the event something goes wrong. Visit any of the over 100 authorized JET dealers nationwide to see for yourself why so many rely on JET.





# CONTENTS

## SAWING .....004-029

Horizontal Bandsaws .....	006-021
Vertical Bandsaws .....	022-025
Coldsaws .....	026-028
Accessories .....	029

## TURNING .....030-055

Belt Drive Lathes .....	033-035
Geared Head Lathes .....	036-039
Large Spindle Bore Lathes .....	040-045
Accessories .....	046-047
Lathe Packages .....	048-051
Digital Read Outs .....	052-055

## MILLING .....056-081

Mill / Drill Machines .....	058-059
Step Pulley Milling Machines .....	060-061
Variable Speed Milling Machines .....	062-065
CNC Vertical Milling Machines .....	066-072
Digital Read Outs .....	073-075
Accessories .....	076-079
Milling Packages .....	080-081

## DRILLING .....082-101

Bench and Floor Model Drill Press .....	084-086
Variable Speed Drill Presses .....	087-090
Geared Head Drill Presses .....	091-096
Radial Arm Drill Presses .....	097-100
Accessories .....	101

## FORMING .....102-119

Shears .....	104-106
Brakes .....	107-110
Slip Rolls .....	111-112
Miscellaneous Forming .....	113-119

## FINISHING .....120-130

Bench Grinders .....	122
Belt and Disc Machines .....	123-126
Square Wheel Grinders .....	127
Disc Finishing Machines .....	128-129
Belt & Chamfering Machines .....	130

## WARRANTY .....131





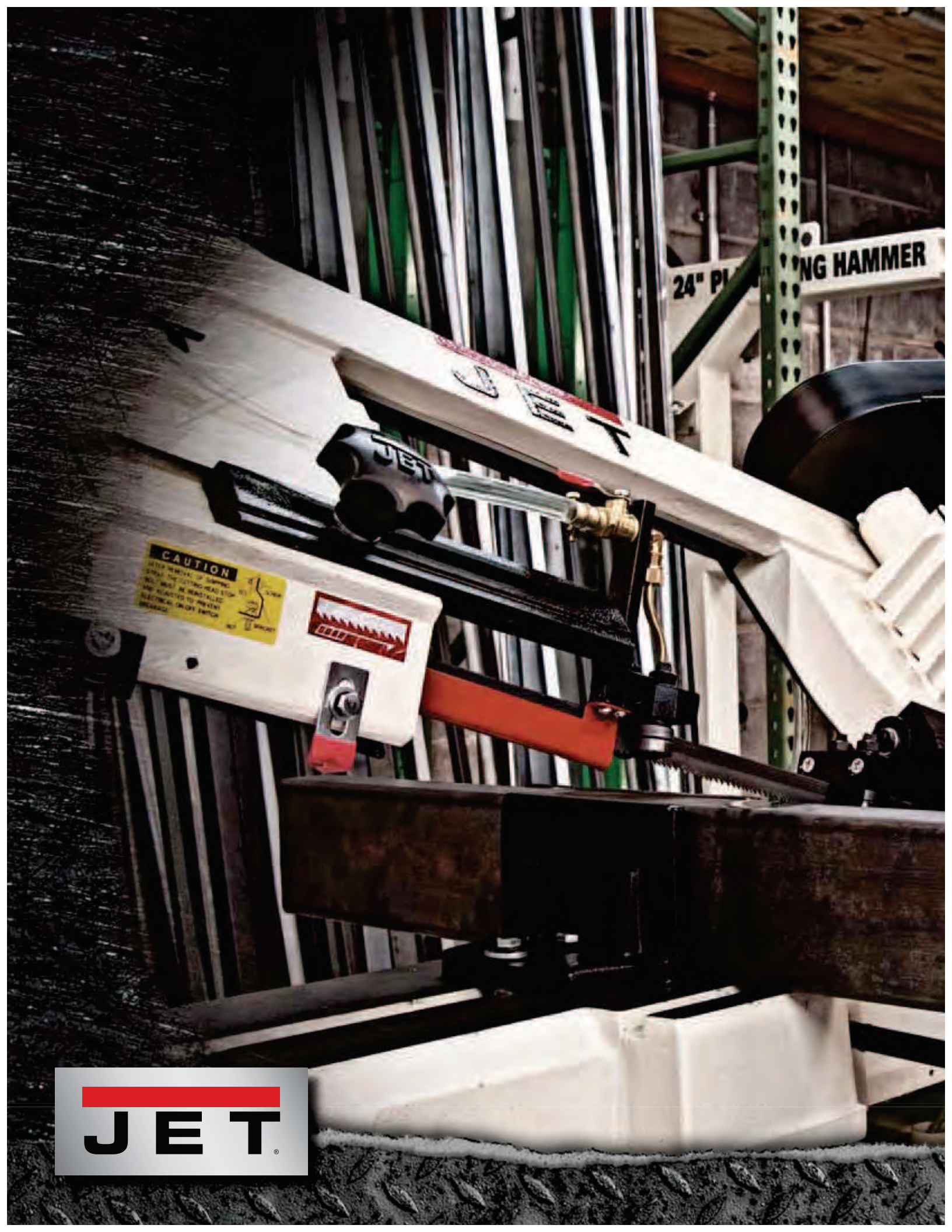

**CAUTION**  
AFTER REMOVAL OF SAWING,  
SMALL PARTICLES AND STEEL  
SWISP MUST BE REARDED  
AND REARDED TO PREVENT  
ELECTRICAL SHORT SWITCH  
OVERHEAT



24" PL... NG HAMMER





A man with safety glasses is operating a large industrial saw in a workshop. The saw is white and black, and the man is focused on his work. The background shows a workshop environment with wooden beams and various tools.

# SAWING

Whether you work in the shop or out on site, JET saws deliver precision cuts for even the most heavy-duty jobs. Horizontal and Vertical Band Saws, Cold Saws and Sawing Accessories – whatever your needs, JET manufactures these machines to provide consistent, high-quality results cut after cut. Backed by one of the industry's top warranties, and accompanied by professional operation manuals, JET machines are up and running faster, longer and more efficiently than the competition.

**HIGH-QUALITY  
RESULTS - CUT  
AFTER CUT**



# HORIZONTAL BANDSAWS

High-performance JET Horizontal Bandsaws enable your shop to make the cuts needed for any job. Heavy-duty rigid steel and cast iron construction, variable-speed drive systems, and counterbalance feed are among some of the features that ensure you get quality results cut after cut. JET Horizontal, Horizontal Mitering and Semi-Automatic Horizontal Bandsaws are built to last; metalworking professionals and commercial machine shops around the country rely on JET.



## 5" x 6" HORIZONTAL / VERTICAL BANDSAW

### FEATURES

- UL Listed single phase motor
- Exclusive design heavy-duty 14-gauge stand
- Large diameter wheels and built-in handle allows easy movement
- Front legs feature adjustable leveling pads
- Ball bearing supported blade wheel
- Fully adjustable ball bearing blade guides
- Heat-treated and ground steel worm gear with bronze drive gear
- Three blade speeds
- Automatic shut-off after cut

### STANDARD EQUIPMENT

- Vertical worktable
- 1/2" Carbon steel blade
- Adjustable material stop

<b>STOCK NUMBER</b>	414458
<b>Model Number</b>	HVBS-56M
<b>CUTTING CAPACITIES</b>	
<b>Round Capacity at 90° (in.)</b>	5
<b>Round Capacity at 45° (in.)</b>	3
<b>Rectangle Capacity at 90° (in.)</b>	5 (H) x 5-3/4 (W) & 2 (H) x 6 (W)
<b>Rectangle Capacity at 45° (in.)</b>	4-1/2 (H) x 3 (W)
<b>Throat Depth (in.)</b>	5
<b>Vertical Worktable (in.)</b>	9-5/8 x 9-1/2
<b>Vise Swivels (deg.)</b>	45
<b>Blade Size (in.)</b>	1/2 x .025 x 64-1/2
<b>Blade Wheel Diameter (in.)</b>	7-3/8
<b>Blade Speed (SFPM)</b>	80, 120, 200
<b>Bed Height (in.)</b>	26
<b>Motor</b>	1/2HP, 115/230V, 1Ph, Prewired 115V
<b>Floor Space Required (in./ L x W x H)</b>	36 x 20 x 39.5
<b>Net Weight (lbs.)</b>	115



<b>OPTIONAL EQUIPMENT</b>	<b>STOCK NUMBER</b>
Replacement Blade - 1/2" x .025" x 64-1/2" x 14R-C	414301





# 5" x 6" SWIVEL HEAD BANDSAW

**2**  
YEAR  
WARRANTY

## FEATURES

- Head swivels for a maximum cut at 45° & 60°
- Hydraulic down feed control
- Deluxe enclosed stand with handle and wheels for easy movement
- Ball bearing drive wheel and blade guides
- Sealed worm gear transmission
- UL Listed motor

## STANDARD EQUIPMENT

- 1/2" Carbon steel blade
- Adjustable material stop



STOCK NUMBER	414457
Model Number	HBS-56S
CUTTING CAPACITIES	
Round Capacity at 90° (in.)	5
Round Capacity at 45° (in.)	3
Round Capacity at 60° (in.)	1-3/4
Rectangle Capacity at 90° (in.)	5 x 6; 2 x 6-3/4
Rectangle Capacity at 45° (in.)	4 x 2-3/4; 2 x 3-3/4
Rectangle Capacity at 60° (in.)	5 x 1-3/4
Blade Size (in.)	1/2 x .025 x 64-1/2
Blade Wheel Diameter (in.)	7-3/8
Blade Speed (SFPM)	80, 120, 200
Bed Height (in.)	28
Motor	1/2HP, 115/230V, 1Ph, Prewired 115V
Floor Space Required (in./ L x W x H)	37 x 20-3/4 x 41
Net Weight (lbs.)	172

OPTIONAL EQUIPMENT	STOCK NUMBER
Replacement Blade - 1/2" x .025" x 64-1/2" x 14R-C	414301



Hydraulic Down Feed Control



414301 Blade



# 5" x 8" HORIZONTAL BANDSAW

# NEW!

## FEATURES

- Adjustable hydraulic feed system
- Adjustable ball bearing guides
- Heat treated steel worm gear and bronze drive gear
- Automatic shut off at end of cut
- Handle and wheels for convenient moving to various work stations

## STANDARD EQUIPMENT

- 1 gallon capacity coolant system, 115V/1Ph, complete with hose, flexible nozzle, shut off valve, tank and baffle
- Eccentric shaft and ball bearing side blade guides
- Ball bearing rear blade guides
- 1/2" carbon steel blade

STOCK NUMBER	414453
Model Number	J-3230
CUTTING CAPACITIES	
Round Capacity at 90° (in.)	5
Round Capacity at 45° (in.)	4-1/2
Rectangle Capacity at 90° (in.)	7-1/2 x 5
Rectangle Capacity at 45° (in.)	4-1/2 x 5
Blade Size (in.)	1/2 x .025 x 68-1/2
Blade Wheel Diameter (in.)	7-1/2
Blade Speed (SFPM)	85, 125, 200
Bed Height (in.)	23-1/2
Motor	1/2HP, 115V, 1Ph, 1725RPM
Floor Space Required (in./ L x W x H)	37 x 16 x 37
Net Weight (lbs.)	134



OPTIONAL EQUIPMENT	STOCK NUMBER
Replacement Blade - 1/2" x .025" x 64-1/2" x 14R-C	414301

# JET



# 7" x 12" HORIZONTAL / VERTICAL BANDSAW

**2**  
YEAR WARRANTY

## FEATURES

- UL listed motor
- Heavy cast iron bow and bed
- Hydraulic downfeed for ease of cut
- Hardened and ground worm gear
- Roller cabinet with built-in chip tray
- Automatic shut-off after cut

## STANDARD EQUIPMENT

- Vertical worktable
- Coolant system
- 3/4" Bi-metal blade
- Adjustable material stop
- Chip brush



## HVBS-7MW METALWORKING BANDSAW

The JET HVBS-7MW Metalworking Bandsaw is powered by a 3/4HP UL approved motor. Four wheels and built in handle allow easy movement. Each HVBS-7MW comes equipped with a 3/4" carbon steel blade, adjustable material stop and vertical worktable. You can be confident in the safety features offered on the HVBS-7MW with the automatic shut off after each cut.

OPTIONAL EQUIPMENT	STOCK NUMBER
Replacement Blade - 3/4" x .035" x 93" x 6/10VT	414304
Replacement Blade - 3/4" x .035" x 93" x 6R	5632142
Replacement Blade - 3/4" x .035" x 93" x 8R	5632141
Replacement Blade - 3/4" x .035" x 93" x 10R	5632151
Replacement Blade - 3/4" x .035" x 93" x 14R	5632161

STOCK NUMBER	414459
Model Number	HVBS-7MW
CUTTING CAPACITIES	
Round Capacity at 90° (in.)	7
Round Capacity at 45° (in.)	4-1/2
Rectangle Capacity at 90° (in.)	2 (H) x 12 (W) / 7 (H) x 10-7/8 (W)
Rectangle Capacity at 45° (in.)	7 (H) x 3-1/2 (W) / 5-1/2 (H) x 4-1/2 (W)
Throat Depth (in.)	7
Vertical Tables (in.)	9-3/8 x 10
Vise Swivels (deg.)	45
Blade Size (in.)	3/4 x .035 x 93
Blade Wheel Diameter (in.)	11-3/4
Blade Speed (SFPM)	86, 132, 178, 260
Bed Height (in.)	23
Motor	3/4HP, 115/230V, 1Ph, Prewired 115V
Floor Space Required (in./ L x W x H)	49-1/2 x 20-1/2 x 41
Net Weight (lbs.)	286



# 7" x 12" HORIZONTAL BANDSAW

# NEW!

## FEATURES

- Blade guides – side-eccentric shaft and ball bearing; rear-ball bearing
- Blade drive is steel, heat treated worm driving a bronze worm gear in oil bath
- Heavy duty cast iron saw head and table
- Blade wheels are made of flanged cast iron
- Adjustable hydraulic feed system
- Automatic shut-off at end of cut

## STANDARD EQUIPMENT

- Rapid acting vise
- Coolant pump 1 gallon, 1Ph motor, complete with hose, flexible nozzle, shut-off valve, tank and baffle
- Wheel kit for convenient moving to various work stations
- 3/4" bi-metal blade
- Adjustable material stop

STOCK NUMBER	414454	414455
Model Number	J-3410	J-3410-2
<b>CUTTING CAPACITIES</b>		
Round Capacity at 90° (in.)	7	7
Round Capacity at 45° (in.)	4-1/2	4-1/2
Rectangle Capacity at 90° (in.)	2 x 12 / 7 x 10-1/2	2 x 12 / 7 x 10-1/2
Rectangle Capacity at 45° (in.)	7 x 3-1/2	7 x 3-1/2
Blade Size (in.)	3/4 x .035 x 93	3/4 x .035 x 93
Blade Wheel Diameter (in.)	11-7/16	11-7/16
Blade Speed (SFPM)	80, 130, 180, 265	80, 130, 180, 265
Bed Height (in.)	23-1/2	23-1/2
Motor	3/4HP, 115V, 1Ph,	3/4HP, 220V, 1Ph
Floor Space Required (in./ L x W x H)	50 x 18 x 41	50 x 18 x 41
Net Weight (lbs.)	308	308

## OPTIONAL EQUIPMENT

OPTIONAL EQUIPMENT	STOCK NUMBER
Replacement Blade - 3/4" x .035" x 93" x 6R	5632142
Replacement Blade - 3/4" x .035" x 93" x 8R	5632141
Replacement Blade - 3/4" x .035" x 93" x 10R*	5632151*
Replacement Blade - 3/4" x .035" x 93" x 14R	5632161

\*Supplied as standard on bandsaw



5632142 Blade



414454



# JET

OIO



# 8" x 13" HORIZONTAL BANDSAW

## FEATURES

- Heavy duty, rigid steel and cast iron construction of the head and base provides full blade support and eliminates vibration and deflection.
- The combination of an oil bath, gear reduction power train, along with precision blade guides and a hydraulic feed system delivers consistent, accurate cuts and longer blade life.
- Conveniently located control panel and an easily accessible coolant system
- Dual voltage electrics (115V/230V) with overload and low voltage protection
- Easy to use belt drive tensioner does not require tools for blade speed changes or belt replacement
- Longer blade wheel base reduces blade fatigue and increases blade life

## STANDARD EQUIPMENT

- Rapid acting vise (allows miter cutting to 45°)
- Coolant system
- 1" Bi-metal blade
- Adjustable material stop

**2**  
YEAR  
WARRANTY



**NEW!**

STOCK NUMBER	414450
Model Number	J-7015
CUTTING CAPACITIES	
Round Capacity at 90° (in.)	9
Round Capacity at 45° (in.)	9
Rectangle Capacity at 90° (in.)	9 x 13
Rectangle Capacity at 45° (in.)	9 x 8
Blade Size (in.)	1 x .035 x 114.5
Blade Wheel Diameter (in.)	11-5/8
Blade Speed (SFPM)	82, 132, 170, 235
Bed Height (in.)	27-1/2
Motor	1.5HP, 115/230V, 1Ph, Prewired 115V
Floor Space Required (in./ L x W x H)	62-1/2 x 23 x 48
Net Weight (lbs.)	551

OPTIONAL EQUIPMENT	STOCK NUMBER
Replacement Blade - 1" x .035" x 114-1/2" x 4/6VT	5516191
Replacement Blade - 1" x .035" x 114-1/2" x 8/12VT	5516193



5516191 Blade

**SAWING**

OIL



# 8" x 14" HORIZONTAL GEARED HEAD BANDSAW

## FEATURES

- Heavy-duty geared head transmission for quick speed changes
- Easy accessible control panel for operator use
- Hydraulic feed
- Portable on wheels
- Hardened and ground worm gears
- Miters at 45°

## STANDARD EQUIPMENT

- Coolant system
- 3/4" Bi-metal blade
- Adjustable material stop
- Chip brush



<b>STOCK NUMBER</b>	<b>414466</b>
Model Number	HBS-814GH
<b>CUTTING CAPACITIES</b>	
Round Capacity at 90° (in.)	8
Round Capacity at 45° (in.)	6-1/2
Rectangle Capacity at 90° (in.)	14 x 8 / 2 x 14
Rectangle Capacity at 45° (in.)	6-1/2 (H) x 6 (W) & 2 (H) x 7 (W)
Throat Depth (in.)	8
Vise Swivels (deg.)	45
Blade Size (in.)	3/4 x .035 x 97
Blade Wheel Diameter (in.)	12
Blade Speed (SFPM)	135, 197, 256
Bed Height (in.)	26
Motor	1HP, 115/230V, 1Ph, Prewired 115V
Floor Space Required (in./ L x W x H)	51-1/2 x 18-1/8 x 44
Net Weight (lbs.)	400

## OPTIONAL EQUIPMENT

## STOCK NUMBER

Replacement Blade - 3/4" x .035" x 97" x 8R-C	5674032
Replacement Blade - 3/4" x .035" x 97" x 5/8VT	5674033
Replacement Blade - 3/4" x .035" x 97" x 8/12VT	5674034



Easy Accessible Control Panel



Coolant System Reservoir



5674032 Blade



# 7" AND 8 - 3/4" ZIP MITER HORIZONTAL BANDSAW

**NEW!**

## FEATURES

- Adjustable hydraulic feed system
- Eccentric shaft ball bearings
- Heavy duty cast iron saw head and sturdy base
- Mitering capability to 60°
- Convenient control panel

## STANDARD EQUIPMENT

- Complete coolant system
- Hydraulic blade tension gauge
- Adjustable material stop
- Bi-Metal bandsaw blade
- Overload protection



414464

STOCK NUMBER	414464	414467
Model Number	J-9180-3	J-9225
<b>CUTTING CAPACITIES</b>		
Round Capacity at 90° (in.)	7	8-3/4
Round Capacity at 45° (in.)	4-1/2	6-1/4
Rectangle Capacity at 90° (in.)	7 x 7	8-3/4 x 7
Rectangle Capacity at 45° (in.)	4-1/2 x 4-1/2	6-1/4 x 7-1/4
Vise Swivels (deg.)	60	60
Blade Size (in.)	3/4 x .035 x 82	1 x .035 x 96-1/2
Blade Wheel Diameter (in.)	10-1/2	11-5/8
Bed Height (in.)	35-7/8	38-7/16
Motor	1HP, 230V, 3Ph	1-1/2HP, 230V, 3Ph
Floor Space Required (in./ L x W x H)	47 x 29 x 56-1/2	51 x 33 x 59-1/4
Net Weight (lbs.)	385	485





# 9" x 16" HORIZONTAL BANDSAW

## FEATURES

- Large hand-wheel and built-in gauge for easy blade tensioning
- Coolant is distributed through the blade guides
- Blade guides feature parallel double row ball bearing support
- Blade brush is built-in and self-propelled
- Quick-positioning vise with fully adjustable jaws swivels to 45°
- Removable chip tray for quick clean-up
- Blade is fully guarded regardless of blade guide position
- Fully adjustable hydraulic downfeed with separate on/off valve

## STANDARD EQUIPMENT

- Automatic shut-off after cut
- Carbide blade guides with rollers
- Coolant system
- 4/6VT Bi-metal blade
- Adjustable material stop

<b>STOCK NUMBER</b>	414468
<b>Model Number</b>	HBS-916W
<b>CUTTING CAPACITIES</b>	
<b>Round Capacity at 90° (in.)</b>	9
<b>Round Capacity at 45° (in.)</b>	6-1/8
<b>Rectangle Capacity at 90° (in.)</b>	2 x 16 / 8-1/2 x 14
<b>Rectangle Capacity at 45° (in.)</b>	9 x 6-1/8
<b>Vise Swivels (deg.)</b>	45
<b>Blade Size (in.)</b>	1 x .035 x 119-1/2
<b>Blade Wheel Diameter (in.)</b>	13
<b>Blade Speed (SFPM)</b>	82, 132, 170, 235
<b>Bed Height (in.)</b>	25
<b>Motor</b>	1-1/2HP, 115/230V, 1Ph, Prewired 115V
<b>Floor Space Required (in./ L x W x H)</b>	65 x 28 x 42
<b>Net Weight (lbs.)</b>	625

## HBS-916W METAL WORKING BANDSAW

The JET HBS-916W Horizontal Bandsaw is one of the leading tools of its kind. It comes equipped with tons of features: a large handwheel, built-in gauge, blade guides, blade brush, quick-positioning vise, and removable chip tray just to name a few. The HBS-916W automatically shuts off after a cut for safety. Each horizontal bandsaw comes with a 4/6VT Bi-Metal blade and 2 year warranty.



Easy-To-Read Scale



414305 Blade



**JET**



# 10" x 16" HORIZONTAL BANDSAW

**NEW!**

**2**  
YEAR  
WARRANTY

## FEATURES

- 10" x 16" Horizontal Bandsaw
- Variable speed drive system allows the operator to fine tune the blade speed fast and easily
- Exclusive 6 contact point blade guide assemblies
- Exclusive swivel control panel
- One piece wheel cover
- Heavy duty rugged transmission utilizes hardened and ground gears operating in an oil bath

## STANDARD EQUIPMENT

- Swing away control panel
- Patented 3 jaw rapid action vise
- Cast iron blade wheels
- Coolant system
- 1" Bi-metal blade
- Adjustable material stop



414472

STOCK NUMBER	414472	414478	414499
Model Number	J-7020	J-7040	J-7040-4
<b>CUTTING CAPACITIES</b>			
Round Capacity at 90° (in.)	10	10	10
Round Capacity at 45° (in.)	10	10	10
Rectangle Capacity at 90° (in.)	7 x 16 / 10 x 10	7 x 16 / 10 x 10	7 x 16 / 10 x 10
Rectangle Capacity at 45° (in.)	6-1/2 x 11	6-1/2 x 11	6-1/2 x 11
Blade Size (in.)	1 x .035 x 130	1 x .035 x 130	1 x .035 x 130
Blade Wheel Diameter (in.)	14	14	14
Blade Speed (SFPM)	100 - 350	100 - 350	100 - 350
Bed Height (in.)	23-1/2	23-1/2	23-1/2
Motor	1-1/2HP, 115/230V, 1Ph, Prewired 230V	2HP, 3Ph	2HP, 460V, 3Ph, Prewired 460V
Floor Space Required (in./ L x W x H)	75-1/2 x 33 x 41	75-1/2 x 33 x 41	75-1/2 x 33 x 41
Net Weight (lbs.)	927	927	927

OPTIONAL EQUIPMENT	STOCK NUMBER
Replacement Blade - 1" x .035" x 135" x 4/6VT	5674011
Replacement Blade - 1" x .035" x 135" x 5/8VT	5674022
Replacement Blade - 1" x .035" x 135" x 6/10VT	5674021

**SAWING**



# 10" x 16" HORIZONTAL MITERING BANDSAW

**NEW!**

**2**  
**YEAR** WARRANTY

## FEATURES

- Variable speed drive system allows the operator to fine tune the blade speed fast and easily
- Exclusive six contact point blade adjustable guide assemblies
- Combined with the side bearings are carbide pads, the back of the blade rides on two load bearings mounted on a pivot shaft so both bearings share the load equally
- Mitering head – the workpiece remains fixed while the head swivels to cut any angle 0° - 45°
- Heavy duty transmission utilizes hardened and ground gears operating in an oil bath
- Counterbalanced feed system is controlled by a dual system of counterbalance springs working with a hydraulic cylinder.

## STANDARD EQUIPMENT

- Swing away control panel
- Cast iron blade wheels
- Coolant system
- 1" Bi-metal blade
- Adjustable material stop



414474

STOCK NUMBER	414474	414475	414484
Model Number	J-7020M	J-7040M	J-7040M-4
<b>CUTTING CAPACITIES</b>			
Round Capacity at 90° (in.)	10	10	10
Round Capacity at 45° (in.)	8-1/2	8-1/2	8-1/2
Rectangle Capacity at 90° (in.)	2 x 16 / 10 x 14	2 x 16 / 10 x 14	2 x 16 / 10 x 14
Rectangle Capacity at 45° (in.)	8-1/2 x 9	8-1/2 x 9	8-1/2 x 9
Vise Swivels (deg.)	45	45	45
Blade Size (in.)	1 x .035 x 135	1 x .035 x 135	1 x .035 x 135
Blade Wheel Diameter (in.)	14	14	14
Blade Speed (SFPM)	100-350	100 - 350	100 - 350
Bed Height (in.)	25-1/2	25-1/2	25-1/2
Motor	1-1/2HP, 115/230V, 1Ph, Prewired 230V	2HP, 230/460V, 3Ph, Prewired 230V	2HP, 230/460V, 3Ph, Prewired 460V
Floor Space Required (in./ L x W x H)	76 x 30 x 48	76 x 30 x 48	76 x 30 x 48
Net Weight (lbs.)	1,134	1,125	1,125

**JET**



# 10" x 14" HORIZONTAL MITERING BANDSAW

**2**  
YEAR WARRANTY

## FEATURES

- Unique design features a swivel-head for miter cutting structurals, pipe and tubing
- Miter head swivels from 90° to 45° while the stock remains in the same position
- Large, easy-to-read scale for positioning saw head
- Quick-positioning vise reduces set-up time
- Large handwheel and built-in gauge for easy blade tensioning
- Coolant is distributed through the blade guides
- Blade brush is built-in and self-propelled
- Fully adjustable hydraulic downfeed with separate on/off valve

## STANDARD EQUIPMENT

- Automatic shut-off after cut
- Carbide blade guides with rollers
- Coolant system
- 4/6VT Bi-metal blade
- Adjustable material stop



Easy-To-Read Scale



Removable Chip Tray



414311 Blade

STOCK NUMBER	414477
Model Number	MBS-1014W-1
CUTTING CAPACITIES	
Round Capacity at 90° (in.)	10
Round Capacity at 45° (in.)	9
Rectangle Capacity at 90° (in.)	15
Rectangle Capacity at 45° (in.)	9 x 8-1/2
Vise Swivels (deg.)	45
Blade Size (in.)	1 x .035 x 130
Blade Wheel Diameter (in.)	14
Blade Speed (SFPM)	82, 132, 210, 330
Bed Height (in.)	25
Motor	2HP, 230V Only, 3Ph
Floor Space Required (in./ L x W x H)	36 x 68 x 43
Net Weight (lbs.)	948

OPTIONAL EQUIPMENT	STOCK NUMBER
Replacement Blade - 1" x .035" x 130" x 4/6VT	414311



# 10" x 18" HORIZONTAL BANDSAW

**2**  
YEAR  
WARRANTY

## FEATURES

- Large hand wheel and built-in gauge for easy blade tensioning
- Coolant is distributed through the blade guides
- Blade guides feature parallel double-row ball bearing support
- Blade brush is built-in and self-propelled
- Quick-positioning vise with fully adjustable jaws swivels to 45°
- Removable chip tray for quick clean-up
- Blade is fully guarded regardless of blade guide position
- Fully adjustable hydraulic downfeed with separate on/off valve

## STANDARD EQUIPMENT

- Automatic shut-off after cut
- Carbide blade guides with rollers
- Coolant system
- 4/6VT Bi-metal blade
- Adjustable material stop



<b>STOCK NUMBER</b>	<b>414473</b>
Model Number	HBS-1018W
<b>CUTTING CAPACITIES</b>	
Round Capacity at 90° (in.)	10
Round Capacity at 45° (in.)	7-1/2
Rectangle Capacity at 90° (in.)	10 x 16 and 6-1/2 x 18
Rectangle Capacity at 45° (in.)	10 x 7-1/2
Vise Swivels (deg.)	45°
Blade Size (in.)	1 x .035 x 130-1/2
Blade Wheel Diameter (in.)	14
Blade Speed (SFPM)	82, 132, 210, 330
Bed Height (in.)	23-1/2
Motor	2HP, 230V only, 1Ph
Floor Space Required (in./ L x W x H)	69 x 28 x 42-3/4
Net Weight (lbs.)	705

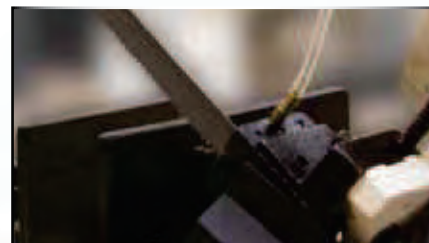

**Carbide Blade Guides**



**Removable Chip Tray**

<b>OPTIONAL EQUIPMENT</b>	<b>STOCK NUMBER</b>
Replacement Blade - 1" x .035" x 130-1/2" x 4/6VT	414308
Replacement Blade - 1" x .035" x 130-1/2" x 8/12VT	414310



**414308 Blade**



# 12" x 20" SEMI-AUTOMATIC HORIZONTAL BANDSAW

## FEATURES

- Variable speed drive system allows the operator to fine tune the blade speed fast and easily
- Exclusive swivel control panel
- Heavy duty transmission utilizes hardened and ground gears operating in an oil bath
- Counterbalanced feed system is controlled by a dual system of counterbalance springs working with a hydraulic cylinder
- Saw head raised hydraulically after each cut
- Cast iron band wheels
- Swing away control panel

- Exclusively patented 3 jaw vise allows for faster set up
- Exclusive six contact point blade adjustable guide assemblies utilize cam follower bearings mounted on eccentric shafts on both sides of the blade

## STANDARD EQUIPMENT

- Coolant system
- 1" Bi-metal blade
- Adjustable material stop

**NEW!**



STOCK NUMBER	414476
Model Number	J-7060
CUTTING CAPACITIES	
Round Capacity at 90° (in.)	12
Round Capacity at 45° (in.)	12
Rectangle Capacity at 90° (in.)	12 x 20
Rectangle Capacity at 45° (in.)	12 x 12
Blade Size (in.)	1 x .035 x 156
Blade Wheel Diameter (in.)	17
Blade Speed (SFPM)	82 - 262
Bed Height (in.)	26-1/4
Motor	3HP, 230/460V, 3Ph, Prewired 230V
Floor Space Required (in./ L x W x H)	87 x 37-1/2 x 53
Net Weight (lbs.)	1,456

OPTIONAL EQUIPMENT	STOCK NUMBER
Replacement Blade - 1" x .035" x 156" x 4/6VT	5512107
Replacement Blade - 1" x .035" x 156" x 5/8VT	5674023
Replacement Blade - 1" x .035" x 156" x 6/10VT	5512108



5512107 Blade

**SAWING**



# 13" SEMI-AUTO HORIZONTAL BANDSAW

## FEATURES

- Semi-automatic bow raises after cut is complete to predetermined height
- Fully adjustable hydraulic downfeed controls the rate of descent
- Variable blade speed allows optimum cutting performance
- Safety switch shuts off motor if band breaks
- Quick-positioning vise lessens set-up time
- Large hand wheel and built-in gauge provides easy blade tensioning
- Coolant is distributed through the blade guides
- Cleaning hose and nozzle assist in washing chips away
- Easy access chip tray allows quick cleanup
- Self-propelled blade brush extends the blade life

## STANDARD EQUIPMENT

- Automatic shut-off after cut
- Carbide blade guides with rollers
- Coolant system
- 1-1/4VT Bi-Metal
- Adjustable material stop

<b>STOCK NUMBER</b>	414471
<b>Model Number</b>	HBS-1321W
<b>CUTTING CAPACITIES</b>	
<b>Round Capacity at 90° (in.)</b>	13
<b>Round Capacity at 45° (in.)</b>	10-1/2
<b>Rectangle Capacity at 90° (in.)</b>	10 x 21 and 13 x 19
<b>Rectangle Capacity at 45° (in.)</b>	11-1/2 x 10-1/2
<b>Blade Size (in.)</b>	1-1/4 x .042 x 161-1/2
<b>Blade Wheel Diameter (in.)</b>	18
<b>Blade Speed (SFPM)</b>	80 - 260
<b>Bed Height (in.)</b>	28-3/4
<b>Motor</b>	3HP, 230/460V, 3Ph, Prewired 230V
<b>Floor Space Required (in./ L x W x H)</b>	87 x 32 x 55
<b>Net Weight (lbs.)</b>	1,276



**JET**

020



# 10" HORIZONTAL AUTO SAW

## FEATURES

- FCD50, a highly rigid material, is used to cast a majority of the machine structure. It is combined with an advanced torque enhanced transmission and give 30% more productivity in sawing steel and stainless steel
- Blade breakage detector
- 10 PLC-controlled programs
- 3300lbs load capacity
- Material detecting sensor
- Bundle cutting
- Saw Frame-work height selector
- Broken blade sensor
- Automatic chip-cleaning system
- Dual-vise shuttle feeding system
- Heavy-duty one-piece base assembly
- Heavy duty taper bearing in blade wheels
- Power driven blade brush
- Hydraulic blade tensioning system
- Large ball-bearing supporting the blade guides
- Material-size sensor for rapid travel
- Inverter blade speed control
- Vise pressure regulator

## STANDARD EQUIPMENT

- 2 Meter (6.5FT) Roller Stand
- Numerical Control Feed and Speed System
- PLC Memorize Programmable Cutting (10 programs)
- Chip Cart
- Auger-Type Hydraulic/Automatic Chip Conveyor
- Hydraulic Vertical Press Clamping (Nesting Fixture)
- Blade Breakage Detector
- Work Lamp
- Inverter Blade Speed Control
- Dual Vise Shuttle System
- Saw Frame Work Height Selector
- Out of Stock Sensor
- Hydraulic Blade Tension
- Full Stroke Vises
- Vise Pressure Regulator
- Bundle Clamps
- Power Driven Blade Cleaning Brush

<b>STOCK NUMBER</b>	<b>414462</b>
<b>Model Number</b>	AB-1012W
<b>CUTTING CAPACITIES</b>	
<b>Round Diameter (in.)</b>	10
<b>Rectangle (W x H)</b>	10 x 12
<b>Bundle Width (in.)</b>	6 - 10
<b>Bundle Height (in.)</b>	4 - 6
<b>Minimum Residual Work Length (in.)</b>	2
<b>Maximum Feeding Stroke (in.)</b>	15-3/4
<b>Minimum Stock Diameter (in.)</b>	3/8
<b>No Material Detecting Diameter (in.)</b>	1-1/4
<b>PLC-NC Programmable Cutting Quantities</b>	10 programs
<b>Work Load Capacity (lbs.)</b>	3,306
<b>Blade Size (in.)</b>	1 x 0.035 x 138
<b>Blade Speed (ft/min)</b>	88 - 295
<b>Blade Speed (m/min)</b>	27 - 90
<b>Main Motor</b>	3HP
<b>Coolant Motor</b>	1/6HP
<b>Hydraulic Motor</b>	1HP
<b>Coolant Tank Capacity (gal.)</b>	10.5
<b>Hydraulic Tank Capacity (gal.)</b>	8
<b>Roller Stand Load Capacity (lbs.)</b>	2,200
<b>Table Height (in.)</b>	30
<b>Packaging Size (in./ L x W x H)</b>	90 x 87 x 75
<b>Net Weight (lbs.)</b>	3,153



**NEW!**

**SAWING**



# VERTICAL BANDSAWS

When a project requires long, continuous cuts, contours or intricate cuts, JET Vertical Bandsaws perform flawlessly under shop or production line conditions. These rugged-built JET Vertical Bandsaws handle the heaviest workloads, with models that offer variable speed control, multi-tilting work tables, digital readouts and other features. Every JET sawing machine is built to last, and these precision Vertical Bandsaws are no exception.



**NEW!**

## 14" WOOD / METAL VERTICAL BANDSAWS

### FEATURES

- Cast iron frame
- Solid one piece steel base for extra stability
- Conveniently located on/off switch
- Variable speed drive system (8201VS, 8203VS, J-8201VS & J-8203VS)
- Exclusive gear box design allows wood/metal model saws to be used for a wider variety of metal, wood, non-ferrous metal, plastic cutting applications.

### STANDARD EQUIPMENT

- Miter gauge
- Dust chute
- Saw blades (wood & metal)



414500K

**2**  
YEAR WARRANTY

STOCK NUMBER	414500K	414504K	414502	414503	708116K
Model Number	J-8201K	J-8203K	J-8201VS	J-8203VS	JWBS-14MW
Blade Speeds Metal (SFPM)	39, 57, 78, 107, 142, 196, 278	39, 57, 78, 107, 142, 176, 278	Variable 90-340	Variable 90-340	735, 1,470, 2,350
Blade Speeds Wood (SFPM)	3,300	3,300	2,600	2,600	3,000
Under Guide (in.)	6	6	6	6	-
Under Guide with Riser Block (in.)	12	12	12	12	-
Height Capacity (max./in.)	6	6	6	6	8
Throat Capacity (max./in.)	13-1/2	13-1/2	13-1/2	13-1/2	13-1/2
Table Size (in.)	14 x 14	14 x 14	14 x 14	14 x 14	15 x 15
Table Tilt Right	45°	45°	45°	45°	45°
Table Tilt Left	15°	15°	15°	15°	10°
Blade Length (approx./in.)	92-1/2	92-1/2	92-1/2	92-1/2	93-1/2
Blade Width (min-max/in.)	1/8 - 3/4	1/8 - 3/4	1/8 - 3/4	1/8 - 3/4	1/8 - 3/4
Miter Gauge Groove Wide x Deep (in.)	3/4 x 3/8	3/4 x 3/8	3/4 x 3/8	3/4 x 3/8	3/4 x 3/8
Table Height (in.)	44	44	44	44	43-1/2
Motor	1HP, 115/230V, 1Ph, Prewired 155V	1HP, 230/460V, 3Ph, Prewired 230V	1HP, 115/230V, 1Ph, Prewired 115V	1HP, 230/460V 3Ph, Prewired 230V	1HP, 1Ph, 115/230V, Prewired 115V
Floor Space Required (in./ L x W x H)	26 x 18-1/2 x 67	26 x 18-1/2 x 67	26 x 18-1/2 x 67	26 x 18-1/2 x 67	19 x 26 x 68
Net Weight (lbs.)	171	155	325	325	194

### OPTIONAL EQUIPMENT

OPTIONAL EQUIPMENT	STOCK NUMBER
Rip Fence — fits all models	5782171
Riser block assembly increases height under the guide by 6" — fits all models	5782181
Replacement Blade - 3/8" x .025" x 92-1/2" x 14R-C	5782722
Replacement Blade - 3/8" x .025" x 92-1/2" x 10R-C	5782723

**JET**



# 18" WOOD / METAL VERTICAL BANDSAW

## FEATURES

- Exclusive quick-release, precision T-square style rip fence
- Built-in cutting height scale
- Extra large 19" x 19" cast iron table
- Convenient speed changes with no tools required
- Ball bearing guide system reduces friction for longer blade life
- Lower blade wheel brush and dust collection port



STOCK NUMBER	414418
Model Number	VBS-18MW
Height Capacity (max./in.)	12
Throat Depth (max./in.)	18-3/8
Rip left of blade w/fence (max./in.)	16-1/2
Blade Size (in.)	137 x 3/4 x .035
Blade Length (approx./in.)	137
Blade Width (min-max./in.)	1/8 - 1-1/2 (Wood)
Cutting Speeds Wood (SFPM)	1,000, 1,800, 3,200
Cutting Speeds Metal (SFPM)	80, 150, 265
Table Size (in.)	19 x 19
Table Tilt	R 45°, L 10°
Table Height at 90° (in.)	37-1/2
Motor	1HP, 115/230V, 1Ph, Prewired 115V
Floor Space Required (in./ L x W x H)	42 x 38 x 74
Net Weight (lbs.)	456



# SAWING



# VERTICAL SELF-FEED BANDSAW

**2**  
YEAR WARRANTY

## FEATURES

- Designed for multiple uses cutting both ferrous and nonferrous metals
- Welded frame and base of heavy gauge steel
- Swivel vise for mitering
- Heavy-duty cast iron table
- Four blade speeds
- Hydraulic feed control
- Guide rollers accept blade sizes: 1/8", 1/4", 3/8", 1/2", 5/8", 3/4", 1"

## STANDARD EQUIPMENT

- Four foot pads
- Work lamp
- Chip tray
- Miter gauge
- 5/8" Bi-metal blade
- Extension roller
- Blade speed and pitch selector



Swivel Vise for Mitering



Hydraulic Feed Control

STOCK NUMBER	414486	414487
Model Number	VSF-14-1	VSF-14-3
Blade Speeds (SFPM)	70, 140, 280, 580	70, 140, 280, 580
Height Capacity (max./in.)	14-1/2	14-1/2
Throat Capacity (max./in.)	8-1/2	8-1/2
Table Size (in.)	30-1/2 x 18-1/2	30-1/2 x 18-1/2
Blade Length (approx./in.)	120	120
Blade Width (min-max./in.)	1/8 - 1	1/8 - 1
Table Height (in.)	30	30
Motor	1HP, 115/230V, 1Ph, Prewired 115V	1HP, 230/460, 3Ph, Prewired 230V
Floor Space Required (in./ L x W x H)	49-1/4 x 32-1/4 x 70	49-1/4 x 32-1/4 x 70
Net Weight (lbs.)	550	550

**JET**



# 14", 16", 20" AND 36" VERTICAL BANDSAWS



## COMMON FEATURES

- Heavy Duty completely enclosed steel frame
- Variable speeds provide proper adjustments for high efficiency cutting
- Multi-tilting work surfaces
- Easy to read blade tension indicator

## FEATURES OF THE VBS-3612

- Heavy duty bandsaw can handle large production pieces on its extra large twin tables
- Three wheel system for cutting wide pieces
- Two speed transmission and variable speed allow for wide range of blade speeds

## STANDARD EQUIPMENT

- Blade welder, grinder and cutter
- Worklamp
- Chip Blower
- 1/4" x 14/18 VT Bi-Metal blade
- Blade and tire cleaning brush
- Set of tools

## ADDITIONAL STANDARD EQUIPMENT FOR THE VBS-3612

- Rip fence
- 2 Worktables



414470

414485

STOCK NUMBER	414438	414485	414482	414470
Model Number	VBS-1408	VBS-1610	VBS-2012	VBS-3612
Blade Speeds (SFPM)	82 - 330	Low 82 - 330, High 985 - 3,950	Low 65 - 555, High 390 - 3,280	Low 50 - 410, High 550 - 5,000
Height Capacity (max./in.)	8	10	12	12
Throat Capacity (max./in.)	14	15-1/2	20	36
Table Size (in.)	20 x 20	22 x 24	24 x 22-1/2	23-5/8 x 27-1/2 and 17-3/4 x 27-1/2
Table Tilt	8° F & B, 12° L, 15° R	8° F & B, 12° L, 15° R	8° F & B, 15° R & 12° L	10° L & 45° R
Blade Length (approx./in.)	114	123-1/2	156-1/2	197
Blade Width (min-max./in.)	1/8 - 1/2	1/8 - 5/8	1/8 - 1	1/8 - 1
Table Height (in.)	39	40	39-1/2	40
Motor	1HP, 115/230V, 1Ph, Prewired 115V	2HP, 230/460V, 3Ph, Prewired 230V	2HP, 230/460V, 3Ph, Prewired 230V	3HP, 230/460V, 3Ph, Prewired 230V
Floor Space Required (in./ L x W x H)	34 x 24 x 68-1/2	37 x 28 x 72-1/2	42 x 30 x 79	69 x 32 x 81
Net Weight (lbs.)	634	944	1,244	1,760

## OPTIONAL EQUIPMENT

## STOCK NUMBER

VBS-3612 Replacement Blade - 1/4" x .025" x 197" x 14R-C

5674030

# SAWING



# COLDSAWS

Job site safety is always critical. JET Cold Saws deliver precise, burr-free cuts and easy miters without sparks or generating heat that could pose a danger to the operator or those around them. JET Cold Saws feature rugged design, a reliable coolant system and adjustable workstop for optimal action. Floor models and bench saws enable a shop of any size to deliver meticulous results cut after cut.



## J-F225 BENCH COLDSAW

### J-F225 FEATURES

- Manually cuts from 0 - 45° left
- Bronze worm gear and hardened ground worm screw gear box in an oil bath
- Control handle with a safety spring loaded trigger switch to start or stop the machine
- Coolant system
- Manual vise
- Adjustable depth stop



STOCK NUMBER	414220
Model Number	J-F225
<b>CUTTING CAPACITIES</b>	
Round at 90° (in.)	2-1/2
Round at 45° (in.)	2
Rectangle at 90° (in.)	2-1/2 x 2-15/16
Rectangle at 45° (in.)	1-3/4 x 1-1/4
Square at 90° (in.)	2-1/4
Square at 45° (in.)	1-5/8 x 1-5/8
Blade Size (mm.)	225
Blade Speed (RPM)	52
Motor	1HP, 115V, 1Ph
Floor Space Required (in./ L x W x H)	30 x 17 x 32
Net Weight (lbs.)	84

OPTIONAL EQUIPMENT	STOCK NUMBER
Replacement Blade - 225 - 2 - 32 / 180 Teeth	579000
Replacement Blade - 225 - 2 - 32 / 120 Teeth	579002



# MANUAL FERROUS COLDSAWS CS AND FK350 SERIES

## CS SERIES FEATURES

- Heavy duty cast iron frame base standard
- Cast dual pivot saw head
- Two cutting speeds
- Hardened and ground worm and wheel gear box
- 1.3 gallon coolant tank capacity

## FK350 FEATURES

- 350mm Ferrous cold saw for steel, stainless and tough to cut alloys
- Sturdy gear box design
- Manually cuts from 45° left to 45° right
- Miter stops at 90°, 45° left to 45° right
- Double self centering vise for burr free cuts
- Two cutting speeds
- Thermal overload protection with magnetic starter



STOCK NUMBER	414226	414227	414214	414217
Model Number	CS-275	CS-315	J-FK350-2K	J-FK350-4K
<b>CUTTING CAPACITY FOR TUBING</b>				
Round at 90° (in.)	3-5/16	3-1/2	4-1/2	4-1/2
Round at 45° (in.)	3-5/16	3-1/2	3-1/2	3-1/2
Square at 90° (in.)	2-1/2 x 2-1/2	3-1/4 x 3-1/4	4-1/4	4-1/4
Square at 45° (in.)	2-1/4 x 2-1/4	2-5/8 x 2-5/8	3-1/2	3-1/2
Rectangle at 90° (in.)	3 x 2	4 x 3-1/4	5-1/2 x 3-3/4	5-1/2 x 3-3/4
Rectangle at 45° (in.)	2-1/4 x 2-5/16	3-1/4 x 2-5/8	3-1/2 x 3-1/2	3-1/2 x 3-1/2
<b>CUTTING CAPACITY FOR SOLID</b>				
Round at 90° (in.)	3-1/3	3-1/2	2	2
Round at 45° (in.)	3-1/3	3-1/2	1-3/4	1-3/4
Square at 90° (in.)	2-1/2 x 2-1/2	3-1/4 x 3-1/4	2	2
Square at 45° (in.)	2-1/4 x 2-1/4	2-5/8 x 2-5/8	1-3/4	1-3/4
Blade Size (mm)	275 x 32 x 2	315 x 32 x 2	350 x 32 x 2.5	350 x 32 x 2.5
Blade Speeds (RPM)	54, 108	52, 104	44, 88	44, 88
Maximum Vise Opening (in.)	4	4-3/4	6	6
Motor	1.5HP, 230V, 3Ph	2HP, 230V, 3Ph	2HP, 230V, 3Ph	2HP, 460V, 3Ph
Floor Space required (in./ L x W x H)	38 x 37 x 64	39 x 37 x 69	50 x 28 x 60	50 x 28 x 60
Net Weight (lbs.)	350	390	794	794





# NON-FERROUS HIGH SPEED MANUAL COLD SAWS

**2**  
YEAR WARRANTY

## FEATURES

- Mitering capabilities – stops at 90°, 45° left and 45° right
- Double self-centering vise for burr-free cuts
- Two cutting speeds
- Includes one high speed NF 350mm blade (579052)
- Capable of slotting

## STANDARD EQUIPMENT

- Integral flood-style coolant system
- 30" material length stop
- Safety guards



414203

STOCK NUMBER	414203	414207
Model Number	CK350-2K	CK350-4K
<b>CUTTING CAPACITY FOR TUBING</b>		
Round at 90° (in.)	4-1/2	4-1/2
Round at 45° (in.)	3-1/2	3-1/2
Square at 90° (in.)	4-1/4 x 4-1/4	4-1/4 x 4-1/4
Square at 45° (in.)	3-1/2 x 3-1/2	3-1/2 x 3-1/2
Rectangle at 90° (in.)	5-1/2 x 3-3/4	5-1/2 x 3-3/4
Rectangle at 45° (in.)	3-1/2 x 3-1/2	3-1/2 x 3-1/2
<b>CUTTING CAPACITY FOR SOLID</b>		
Round at 90° (in.)	3	3
Round at 45° (in.)	2-1/2	2-1/2
Square at 90° (in.)	3 x 3	3 x 3
Square at 45° (in.)	2-1/2 x 2-1/2	2-1/2 x 2-1/2
Blade Size (mm.)	350 x 32 x 3.4	350 x 32 x 3.4
Blade Speeds (RPM)	1,750, 3,500	1,750, 3,500
Maximum Vise Opening (in.)	6	6
Motor	2HP, 230V, 3Ph	2HP, 460V, 3Ph
Floor Space Required (in./L x W x H)	25 x 52 x 73	25 x 52 x 73
Net Weight (lbs.)	683	683

**JET**



# SAWING ACCESSORIES

## CARBIDE TIPPED COLD SAW BLADES

FOR NON-FERROUS MATERIALS

- All of the carbide blades are three tooth precision tungsten carbide cutting style blades
- They are for general purpose applications
- The 84 teeth blade is for use on medium size solids and extrusions
- The 108 teeth blade is for use on small size solids, tubing and small size extrusions
- These blades are for use on CK High Speed Cold Saws only

STOCK NUMBER	DESCRIPTION
579062	350 - 3.4 - 32 / 84 teeth
579064	350 - 3.4 - 32 / 108 teeth

**90**  
DAY  
WARRANTY

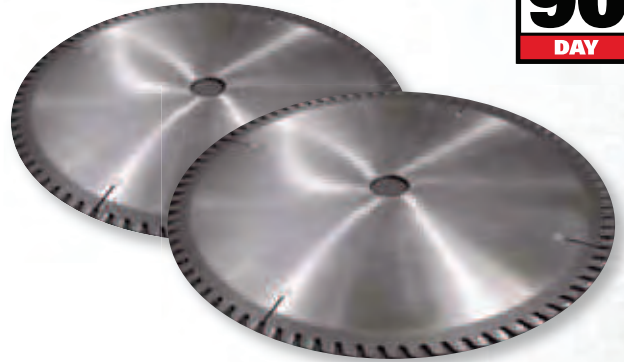

## MATERIAL SUPPORT STANDS

- Heavy-duty cast iron and steel construction
- Chrome plated ball bearing roller head
- Locking screws provide added safety
- The roller heads are interchangeable

STOCK NUMBER	414221	414222
Weight Holding Capacity (lbs.)	2,000	2,000
Minimum Stock Diameter (in.)	-	1
Maximum Stock Diameter (in.)	-	12
Length of Horizontal Roller (in.)	14	-
Height Range (in.)	23.5 - 38.5	23.5 - 38.5
Base/3 Legs Area Required (in.)	16.5 x 16.5 Square	16.5 x 16.5 Square
Stand Dimensions (in./ L x W x H)	22 x 22 x 5	22 x 22 x 5
Net Weight (lbs.)	30	30

STOCK NUMBER	DESCRIPTION
414223	Horizontal Material Support (Head Only)
414224	V-Roller Material Support (Head Only)



Horizontal



V-Roller

**2**  
YEAR  
WARRANTY

**SAWING**



# GHB-1340A

LEAD SCREW		STPI		P					
CROSS SCREW		STPI		P					
LEVER		Q		%					
		AD	NO	AC	BC	AD	NO	AC	BC
IN	NU	8	7	14	38				
	NB	4	8	12	32				
	KV	2	10	11	42				
	LT	6	12	22	42				
T/4	NU	8	7	14	38				
	NB	4	8	12	32				
	KV	2	10	11	42				
	LT	6	12	22	42				
MM	NU	10	20	40	60				
	NB	5	10	20	40				
	KV	2	10	11	42				
	LT	6	12	22	42				
MM	MV	2.5	1.75						
	KV	2.6	1.8	0.8	0.42				
	LB	4	2	1	0.8				
	LT	6	3	1.5	0.75				
MM	NB	8	4.5	2.25					
	JB	10	5	2.5	1.25				

**WARNING**  
STOP SPINDLE  
BEFORE SWAPPING  
SPINDLE AND  
TURRET LEADERS



**JET**  
EQUIPMENT & TOOLS

**JET Equipment & Tools**  
GEARED HEAD PRECISION LATHE  
Model No. GHB-1340A Stock No. 321357A  
Serial No. \_\_\_\_\_ Date \_\_\_\_\_

**WARNING**

1. Read instruction manual before use.  
2. Do not use machine if you are not qualified to do so.  
3. Do not use machine if you are not qualified to do so.  
4. Do not use machine if you are not qualified to do so.  
5. Do not use machine if you are not qualified to do so.  
6. Do not use machine if you are not qualified to do so.  
7. Do not use machine if you are not qualified to do so.  
8. Do not use machine if you are not qualified to do so.  
9. Do not use machine if you are not qualified to do so.  
10. Do not use machine if you are not qualified to do so.







# TURNING

JET's extensive selection of turning machines allows the experts to choose the lathes they need to perform any turning operation. Precision manufactured to meet the demands of even the highest volume shop, JET turning machines, taper attachments, collet closers, digital readouts and accessories are built to last.

JET machines are backed by an industry-best Two year warranty, and come with superior customer support like professional manuals to ensure precise, accurate and efficient operation.

**PRECISION  
MANUFACTURED  
TO MEET YOUR  
DEMANDS**



# JET JHL-610 HOBBY LATHE

## FEATURES

- Electronic Variable Speed 100-2000RPM
- Over-load protection
- Leadscrew is protected under the bed with auto-feed mechanism
- Cross-slide has an industrial-style bolt-down heavy cast-iron tool holder with calibrated feed
- Tailstock has an MT-1 and is made from cast-iron
- Capable of cutting metric thread 0.5-1.25mm pitch
- Capable of cutting inch thread 16-24 TPI

## STANDARD EQUIPMENT

- 3-jaw chuck
- Dead center MT1
- Wrench Set
- Oil Can
- Splash Guard
- Chuck guard with automatic on/off switch for safety
- Gear change kit

STOCK NUMBER	321200
Model Number	JHL-610
Swing over Bed (in.)	5-1/2
Distance Between Centers (in.)	9-3/4
Spindle Bore (in.)	3/8
Spindle Mount	MT-2
Number of Spindle Speeds	Electronic Variable Speed
Range of Spindle Speeds (RPM)	100 - 2,000
Number of Inch Threads	5
Range of Inch Threads (TPI)	16 - 24
Number of Metric Threads	5
Range of Metric Threads	0.5 - 1.25
Max Tool Size (in.)	3/8-shank
Cross Slide Travel (in.)	2-1/2
Carriage Travel (in.)	7-1/16
Taper in Tailstock Spindle	MT-1
Overall Dimensions (in./ L x W x H)	27 x 14 x 13
Motor	150W, 115V, Single Phase
Net Weight (lbs.)	50

OPTIONAL EQUIPMENT	STOCK NUMBER
Stand	350213
11 pc. cutter set	321201
Quick Change cutter rest	321202
Quick Vise	321203
4 Jaw Chuck	321204
Wood tool rest/center	321205
Tool Holder	321206
Clamping Kit for face plate	321207
Lathe Dog	321208
Live Center	321209
Ball Head cutting set	321210
Steady rest	321211
Follow rest	321212



Shown with  
Optional Stand



**JET**



# BELT DRIVE LATHES

The industry standard in Metal Turning, JET Belt Drive Bench Lathes come fully loaded and designed to accommodate a huge variety of optional accessories to perform a variety of operations, while increasing overall production. A JET Belt Drive Bench Lathe allows the operator to change between standard and metric gears quickly and easily to enhance productivity and efficiency, and create finely-shaped tapering with great precision.



## 9" x 20" BELT DRIVE BENCH LATHE

### FEATURES

- Spindle supported by precision tapered roller bearings
- Hardened and ground bedways
- Power Longitudinal feed allows threading and reverse threading
- Standard 1-1/2 x 8 TPI spindle mount allows for many aftermarket accessories
- Reversing switch included for added versatility
- Backlash adjustments provided throughout the carriage
- Tailstock is adjustable for taper cuts
- Quick change gearbox provides wide range of inch and metric threads

### STANDARD EQUIPMENT

- 4" 3-jaw chuck with threaded back plate
- 7" 4-jaw chuck with threaded back plate
- Metric Change gears
- Enclosed gear box
- Centers
- Threading dial



Shown with  
Optional Stand



JETTOOLS.COM

STOCK NUMBER	321376
Model Number	BD-920W
Swing over Bed (in.)	9
Swing over Cross Slide (in.)	5-5/16
Distance Between Centers (in.)	20
Spindle Bore (in.)	7/8
Spindle Mount (TPI)	1/2 x 8
Spindle Taper w/ Sleeve	MT-3
Number of Spindle Speeds	6
Range of Spindle Speeds (RPM)	130 - 2,000
Number of Longitudinal Feed Rates	60
Range of Longitudinal Feeds (IPR)	.0006 - .037
Number of Inch Threads	30
Range of Inch Threads (TPI)	8 - 60
Number of Metric Threads	18
Range of Metric Threads	0.4 - 3.5
Max Tool Size (in.)	1/2 x 1/2
Compound Slide Travel (in.)	1-7/8
Cross Slide Travel (in.)	4-3/8
Carriage Travel (in.)	16
Tailstock Spindle Travel (in.)	1-9/16
Taper in Tailstock Spindle	MT-2
Steady Rest Capacity (in.)	1/4 - 1-7/8
Follow Rest Capacity (in.)	1/4 - 1-1/8
Width of Bed (in.)	4-1/2
Overall Dimensions (in./ L x W x H)	37 x 18-3/4 x 17-3/8
Motor	3/4HP, 1Ph, 115V Only
Net Weight (lbs.)	265

OPTIONAL EQUIPMENT	STOCK NUMBER
S-920N Stand for BD-920N	321374
Lathe with S-920N Stand	321155K

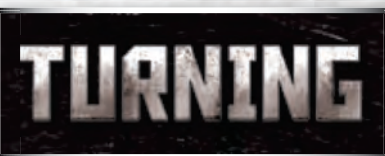



# 13" x 40" BELT DRIVE BENCH LATHE

## FEATURES

- One of the most popular JET lathes now comes with an enclosed gearbox as a standard feature
- Enclosed gearbox design provides smooth, quiet operation
- Fast, easy speed changes
- Low voltage motor controls
- Helical cut headstock gears reduce noise
- Changes gears allow metric threading
- Spindle is supported by precision tapered roller bearings
- V-way bed is induction hardened and ground
- Gap bed section provided for large diameter work
- Independent leadscrew and feed rod
- T-slotted compound slide with four-way tool post
- Carriage mounted spindle control lever
- Automatic feeding and threading are fully interlocked
- Tailstock may be offset for turning tapers and includes an inch/metric graduated quill

## STANDARD EQUIPMENT

- Coolant tray
- Tolerance test certificate
- 6" 3-jaw direct mount scroll chuck with top reversing jaws
- 8" 4-jaw independent chuck
- 12" faceplate
- Four-way tool post
- Steady and follow rest
- Metric change gear
- Centers with headstock center sleeve
- Threading dial
- Micro Carriage Bed Stop
- Tool box with tools



STOCK NUMBER	321360A
Model Number	BDB-1340A
Swing over Bed (in.)	13
Swing over Cross Slide (in.)	7-25/32
Swing Through Gap (in.)	18-3/4
Length of Gap (in.)	8
Distance Between Centers (in.)	40
Spindle Bore (in.)	1-3/8
Spindle Mount	D1-4
Spindle Taper (w/ Sleeve)	MT-5 (MT-3)
Number of Spindle Speeds	12
Range of Spindle Speeds (RPM)	60 - 1,240
Number of Longitudinal and Cross Feed Rates	40
Range of Longitudinal Feeds (IPR)	.0018 - .0374
Range of Cross Feeds (IPR)	.0012 - .0345
Number of Inch Threads	40
Range of Inch Threads (TPI)	4-112
Number of Metric Threads	27
Range of Metric Threads	0.2-6
Max Tool Size (in.)	5/8 x 5/8
Compound Slide Travel (in.)	2-11/16
Cross Slide Travel (in.)	6-5/16
Carriage Travel (in.)	35
Tailstock Spindle Travel (in.)	3-3/4
Taper in Tailstock Spindle	MT-3
Steady Rest Capacity (in.)	2-5/8
Follow Rest Capacity (in.)	2-3/4
Width of Bed (in.)	7-3/8
Overall Dimensions (in./ L x W x H)	71 x 32 x 45 with Stand
Motor	2HP, 1Ph, 230V
Net Weight (lbs.)	1,175

OPTIONAL EQUIPMENT	STOCK NUMBER
Lathe with CBS-1340A Stand	321102AK
Cabinet Stand	321443AK
5C Collet Set (16pc)	650014
Coolant System	321444
Rocker Style Tool Post	321431
Digital Readouts	Available for installation

Refer to pages 46-47 for Lathe Accessories.







Shown with Optional Stand

**TURNING**



# GEARED HEAD LATHES

Yet another advancement in the field of Metal Turning led by JET. Designed for smooth, quiet operation and user versatility a JET Geared Head Bench Lathe cuts and tapers with exacting accuracy. JET Geared Head Bench Lathes feature extensive standard equipment packages that add to the ease of operation and production flexibility.

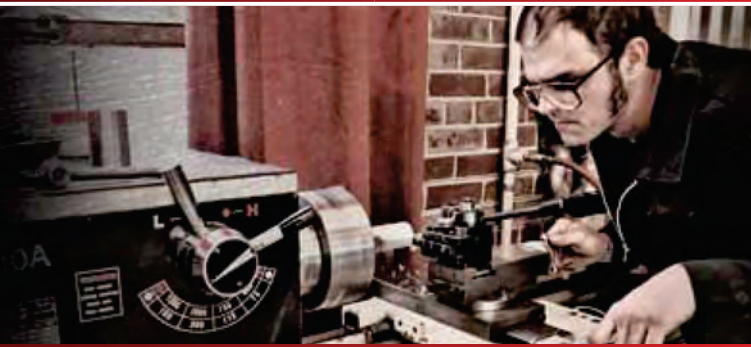

## 13" x 40" GEARED HEAD BENCH LATHE

### FEATURES

- One of the most popular JET lathes now comes with an enclosed gearbox as a standard feature
- Enclosed gearbox design provides smooth, quiet operation
- Fast, easy speed changes
- Hardened and ground gears are featured in the headstock and gearbox
- D1-4 spindle is precision ground for accuracy and supported by high quality tapered roller bearings
- Headstock is constantly oiled during operation
- Gear box gives wide inch threading and feed capabilities with no gear changes
- V-way bed is induction hardened and ground
- Gap bed section provided for large diameter work
- Independent leadscrew and feed rod
- Spindle actuation control is apron mounted
- Compound and cross slide have backlash adjustment
- Adjustable gibs are incorporated in the carriage and slideways
- Tailstock may be offset for turning tapers and includes an inch/metric graduated quill

### STANDARD EQUIPMENT

- Coolant tray
- Tolerance test certificate
- 6" 3-jaw direct mount scroll chuck with top reversing jaws
- 8" 4-jaw independent chuck
- 12" faceplate
- Four-way tool post
- Steady and follow rest
- Metric change gear
- Centers with headstock center sleeve
- Threading dial
- Tool box with tools
- Splash guard
- Micro Carriage Bed Stop



321357A - Shown with Optional Stand

**JET**





Enclosed Gearbox

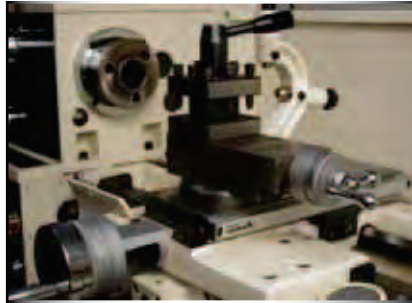

Complete with 4-Way Tool Post and 3-Jaw Chuck Mounted for Ease of Use



STOCK NUMBER	321357A	321359A
Model Number	GHB-1340A	GHB-1440A
Swing over Bed (in.)	13	14
Swing over Cross Slide (in.)	7-25/32	9-1/16
Swing Through Gap (in.)	18-3/4	20
Length of Gap (in.)	8	8
Distance Between Centers (in.)	43	43
Spindle Bore (in.)	1-3/8	1-3/8
Spindle Mount	D1-4	D1-4
Spindle Taper (w/ Sleeve)	MT-5 (MT-3)	MT-5 (MT-3)
Number of Spindle Speeds	8	8
Range of Spindle Speeds (RPM)	70 - 2,000	70 - 2,000
Number of Longitudinal and Cross Feed Rates	40	40
Range of Longitudinal Feeds (IPR)	0.0018 - 0.0374	0.0018 - 0.0374
Range of Cross Feeds (IPR)	0.0006 - 0.0130	0.0006 - 0.0130
Number of Inch Threads	38	38
Range of Inch Threads (TPI)	3-1/2 - 80	3-1/2 - 80
Number of Metric Threads	23	23
Range of Metric Threads	0.45 - 10	0.45 - 10
Max Tool Size (in.)	5/8 x 5/8	5/8 x 5/8
Compound Slide Travel (in.)	2-11/16	2-11/16
Cross Slide Travel (in.)	6-5/16	6-5/16
Carriage Travel (in.)	35	35
Tailstock Spindle Travel (in.)	3-3/4	3-3/4
Taper in Tailstock Spindle	MT-3	MT-3
Steady Rest Capacity (in.)	2-3/4	2-3/4
Follow Rest Capacity (in.)	2-3/8	2-3/8
Width of Bed (in.)	7-3/8	7-3/8
Overall Dimensions (in./ L x W x H)	79 x 28-1/2 x 30	79 x 28-1/2 x 30
Motor	2HP, 1Ph, 230V	2HP, 1Ph, 230V
Net Weight (lbs.)	1,154	1,211

OPTIONAL EQUIPMENT	STOCK NUMBER
Cabinet Stand	321443AK
5C Lever-Type Collet Closer	321514A
5C Collet Set	650014
Coolant System	321444
Rocker Style Tool Post	321431
Digital Readouts	Available for installation

Refer to pages 46-47 for Lathe Accessories.



# 13" x 40" AND 14" x 40" GEARED HEAD ENGINE LATHES

## FEATURES

- Uniquely designed exclusively by JET
- Hardened and ground gears are featured in the headstock and gearbox
- D1-4 spindle is precision ground for accuracy and supported by high-quality tapered roller bearings
- Headstock is constantly oiled during operation
- Splined, not keyed, shafts are utilized in the headstock
- V-way bed design is induction hardened and ground
- Gap bed section provided for larger diameter work
- Independent leadscrew and feed rod
- Spindle actuation control is apron mounted
- Inch-metric dials are standard
- Compound and cross slide have backlash adjustment
- Adjustable gibs are incorporated in the carriage and slideways
- Tailstock may be offset for turning tapers and includes an inch-metric graduated quill
- Tolerance test certificate included

## STANDARD EQUIPMENT

- Heavy-duty Stand
- 6" 3-jaw direct mount scroll chuck with top reversing jaws
- 8" 4-jaw independent chuck
- 12" face plate
- Four-way tool post
- Steady and follow rest
- Micro-carriage bed stop
- Front removable chip tray
- Spindle jog button
- Foot brake
- Coolant system with splash guard
- Metric change gears
- Halogen work lamp



321810



**JET**





STOCK NUMBER	321810	321820	321830	321840
Model Number	GH-1340W-1	GH-1340W-3	GH-1440W-1	GH-1440W-3
Swing over Bed (in.)	13	13	14	14
Swing over Cross Slide (in.)	7-1/4	7-1/4	8-1/4	8-1/4
Swing Through Gap (in.)	19	19	20	20
Length of Gap (in.)	9-3/8	9-3/8	9-3/8	9-3/8
Distance Between Centers (in.)	40	40	40	40
Spindle Bore (in.)	1-1/2	1-1/2	1-1/2	1-1/2
Spindle Mount	D1-4	D1-4	D1-4	D1-4
Spindle Taper (w/ Sleeve)	MT-5 (MT-3)	MT-5 (MT-3)	MT-5 (MT-3)	MT-5 (MT-3)
Number of Spindle Speeds	12	12	12	12
Range of Spindle Speeds (RPM)	40 - 1,800	40 - 1,800	40 - 1,800	40 - 1,800
Number of Longitudinal and Cross Feed Rates	40	40	40	40
Range of Longitudinal Feeds (IPR)	0.0011 - 0.0271	0.0011 - 0.0271	0.0011 - 0.0271	0.0011 - 0.0271
Range of Cross Feeds (IPR)	0.0003 - 0.0103	0.0003 - 0.0103	0.0003 - 0.0103	0.0003 - 0.0103
Number of Inch Threads	40	40	40	40
Range of Inch Threads (TPI)	4 - 112	4 - 112	4 - 112	4 - 112
Number of Metric Threads	22	22	22	22
Range of Metric Threads	0.45 - 7.5	0.45 - 7.5	0.45 - 7.5	0.45 - 7.5
Max Tool Size (in.)	5/8 x 5/8	5/8 x 5/8	5/8 x 5/8	5/8 x 5/8
Compound Slide Travel (in.)	3-1/2	3-1/2	3-1/2	3-1/2
Cross Slide Travel (in.)	6-3/8	6-3/8	6-3/8	6-3/8
Carriage Travel (in.)	37-1/2	37-1/2	37-1/2	37-1/2
Tailstock Spindle Travel (in.)	4-3/4	4-3/4	4-3/4	4-3/4
Taper in Tailstock Spindle	MT-3	MT-3	MT-3	MT-3
Steady Rest Capacity (in.)	3-1/2	3-1/2	3-1/2	3-1/2
Follow Rest Capacity (in.)	2-3/4	2-3/4	2-3/4	2-3/4
Width of Bed (in.)	10-1/4	10-1/4	10-1/4	10-1/4
Overall Dimensions (in./ L x W x H)	78 x 38 x 59	78 x 38 x 59	78 x 38 x 59	78 x 38 x 59
Motor	3HP, 1Ph, 230V	3HP, 3Ph, 230/460V	3HP, 1Ph, 230V	3HP, 3Ph, 230V/460V
Prewired	230V	230V	230V	230V
Net Weight (lbs.)	2,081	2,081	2,191	2,191

OPTIONAL EQUIPMENT	STOCK NUMBER
5C Collet Set (16 pc.)	650014
Taper Attachment Kit	321520
Rocker Style Tool Post	321431
Digital Readouts	Available for installation
<b>NOTE: Use of Static Phase converter will void warranty.</b>	



# LARGE SPINDLE BORE LATHES

A JET-exclusive design, the Large Spindle Bore Lathes provide power, precision, efficiency and reliability to your metal shop. A one-piece, cast iron base absorbs vibrations during operation to allow heavier cuts and ensure accuracy throughout, and the Universal Gearbox eliminates the need for change gears. A loaded standard equipment package makes JET Large Spindle Bore Lathes the model of production proficiency.



## 14" ZX SERIES LARGE SPINDLE BORE LATHES

### FEATURES

- Uniquely designed exclusively by JET
- ISO 9001 certified manufacturer
- Large easy to use foot brake
- 3-1/8" bore spindle is supported by two tapered and one ball bearing
- Chrome molybdenum headstock gears are hardened, ground, and shaved
- Universal gearbox allows inch, metric, diametral, and module pitch threads, no change gears required
- Carriage features one-shot lubrication and Turcite B on bed sliding surfaces
- T-slotted compound slide featuring a four-way tool post
- One-piece cast iron base absorbs vibration allowing heavier cuts
- High quality ANSI Class 50 wear-resistant cast iron bed ways are hardened and ground
- Removable gap allows up to 23-5/8" diameter work
- Five position automatic carriage stop increases productivity
- Attractive chrome control levers, dials, and knobs complete this impressive package

### STANDARD EQUIPMENT

- Tolerance test certificate
- 10" 3-jaw scroll chuck with top reversing jaws
- 12" 4-jaw independent chuck
- 12" face plate
- Four-way tool post
- Follow rest
- Large capacity steady rest
- Fully integrated coolant system
- Full length splash guard and coolant return
- Articulating halogen work lamp
- Centrally located controls with jog button
- Threading dial
- Mounting pads and levelers
- Spindle sleeve (MT-7 to MT-5)
- Dead center and live center





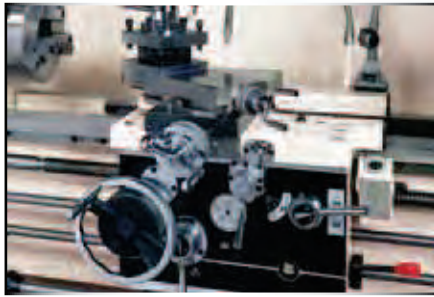

**Carriage Features One-Shot Lubrication and Turcite B on Sliding Surfaces**



**Clean, Simple Design and Well Marked Electrics Make Maintenance on These Lathes Easy!**



321910

STOCK NUMBER	321910	321920
Model Number	GH-1440ZX	GH-1460ZX
Swing over Bed (in.)	14	14
Swing over Cross Slide (in.)	7-5/8	7-5/8
Swing Through Gap (in.)	18	18
Length of Gap (in.)	12	12
Distance Between Centers (in.)	40	60
Spindle Bore (in.)	3-1/8	3-1/8
Spindle Mount	D1-8	D1-8
Spindle Taper (w/ Sleeve)	MT-7 (MT-5)	MT-7 (MT-5)
Number of Spindle Speeds	12	12
Range of Spindle Speeds (RPM)	42 - 1,800	42 - 1,800
Number of Longitudinal and Cross Feed Rates	122	122
Range of Longitudinal Feeds (IPR)	.0015 - .0913	.0015 - .0913
Range of Cross Feeds (IPR)	.0006 - .0365	.0006 - .0365
Number of Inch Threads	61	61
Range of Inch Threads (TPI)	1-5/8 - 72	1-5/8 - 72
Number of Metric Threads	24	24
Range of Metric Threads	.05 - 20	.05 - 20
Max Tool Size (in.)	1 x 1	1 x 1
Compound Slide Travel (in.)	5-1/8	5-1/8
Cross Slide Travel (in.)	9	9
Carriage Travel (in.)	36-9/16	55-9/16
Tailstock Spindle Travel (in.)	5	5
Taper in Tailstock Spindle	MT-4	MT-4
Steady Rest Capacity (in.)	3/8 to 7	3/8 to 7
Follow Rest Capacity (in.)	1/2 - 3-1/2	1/2 - 3-1/2
Width of Bed (in.)	13-1/8	13-1/8
Overall Dimensions (in./ L x W x H)	96 x 44 x 66	116 x 44 x 66
Motor	7-1/2HP, 3Ph, 230V/460V Prewired 230V	7-1/2HP, 3Ph, 230/460V Prewired 230V
Net Weight (lbs.)	5,187	5,380

OPTIONAL EQUIPMENT	STOCK NUMBER
5C Lever-Type Collet Closer	321292
16-pc 5C Collet Set	650014
Taper Attachment Kit	321291
Digital Readouts	Available for installation

**NOTE: Rotary phase converter must be 10HP or higher with high torque kit. Use of static phase converter will void warranty.**



# 16", 18", AND 22" ZX SERIES LARGE SPINDLE BORE LATHES

**2**  
YEAR  
WARRANTY

## FEATURES

- Uniquely designed exclusively by JET
- ISO 9001 certified manufacturer
- Large easy to use foot brake
- 3-1/8" bore spindle is supported by two tapered and one ball bearing
- Chrome molybdenum headstock gears are hardened, ground, and shaved
- Universal gearbox allows inch, metric, diametral, and module pitch threads, no change gears required
- Carriage features one-shot lubrication and Turcite B on bed sliding surfaces
- T-slotted compound slide featuring a four-way tool post
- One-piece cast iron base absorbs vibration allowing heavier cuts
- High quality ANSI Class 50 wear-resistant cast iron bed ways are hardened and ground
- Removable gap allows up to 25-7/8" diameter work on 16", 27-1/2" on 18"
- Five position automatic carriage stop increases productivity
- Attractive chrome control levers, dials, and knobs complete this impressive package

## STANDARD EQUIPMENT

- Tolerance test certificate
- 10" 3-jaw scroll chuck with top reversing jaws
- 12" 4-jaw independent chuck
- 12" face plate (16" models)
- 16" face plate (18" models)
- Four-way tool post
- Follow rest
- Large capacity steady rest
- Fully integrated coolant system
- Full length splash guard and coolant return
- Articulating halogen work lamp
- Centrally located controls with jog button
- Threading dial
- Mounting pads and levelers
- Spindle sleeve (MT-7 to MT-5)
- Live center
- Tool box and adjusting tools



321930

**JET**

042



STOCK NUMBER	321930	321940	321950	321960	321970	321980
Model Number	GH-1640ZX	GH-1660ZX	GH-1840ZX	GH-1860ZX	GH-1880ZX	GH-2280ZX
Swing over Bed (in.)	16	16	18	18	18	22
Swing over Cross Slide (in.)	10	10	11	11	11	13
Swing Through Gap (in.)	25-1/2	25-1/2	27-1/2	27-1/2	27-1/2	29-1/2
Length of Gap (in.)	12	12	12	12	12	12
Distance Between Centers (in.)	40	60	40	60	80	80
Spindle Bore (in.)	3-1/8	3-1/8	3-1/8	3-1/8	3-1/8	3-1/8
Spindle Mount	D1-8	D1-8	D1-8	D1-8	D1-8	D1-8
Spindle Taper (w/ Sleeve)	MT-7 (MT-5)	MT-7 (MT-5)	MT-7 (MT-5)	MT-7 (MT-5)	MT-7 (MT-5)	MT-7(MT-5)
Number of Spindle Speeds	12	12	12	12	12	12
Range of Spindle Speeds (RPM)	25 - 1,800	25 - 1,800	25 - 1,800	25 - 1,800	25 - 1,800	25 - 1,800
Number of Longitudinal and Cross Feed Rates	122	122	122	122	122	122
Range of Longitudinal Feeds (IPR)	.0015 - .0913	.0015 - .0913	.0015 - .0913	.0015 - .0913	.0015 - .0913	.0015 - .0913
Range of Cross Feeds (IPR)	.0006 - .0365	.0006 - .0365	.0006 - .0365	.0006 - .0365	.0006 - .0365	.0006 - .0365
Number of Inch Threads	61	61	61	61	61	61
Range of Inch Threads (TPI)	1-5/8 - 72	1-5/8 - 72	1-5/8 - 72	1-5/8 - 72	1-5/8 - 72	1-5/8 - 72
Number of Metric Threads	24	24	24	24	24	24
Range of Metric Threads	.05 - 20	.05 - 20	.05 - 20	.05 - 20	.05 - 20	.05 - 20
Max Tool Size (in.)	1 x 1	1 x 1	1 x 1	1 x 1	1 x 1	1 x 1
Compound Slide Travel (in.)	5-1/8	5-1/8	5-1/8	5-1/8	5-1/8	5-1/8
Cross Slide Travel (in.)	9	9	9	9	9	12
Carriage Travel (in.)	36-9/16	55-9/16	36-9/16	55-9/16	74-5/16	74-5/16
Tailstock Spindle Travel (in.)	5	5	5	5	5	5
Taper in Tailstock Spindle	MT-4	MT-4	MT-5	MT-5	MT-5	MT-5
Steady Rest Capacity (in.)	3/8 to 7	3/8 to 7	3/8 to 7-3/4	3/8 to 7-3/4	3/8 to 7-3/4	3/8 to 7-3/4
Follow Rest Capacity (in.)	1/2 - 3-1/2	1/2 - 3-1/2	1/2 - 3-1/2	1/2 - 3-1/2	1/2 - 3-1/2	1/2 - 3-1/2
Width of Bed (in.)	13-1/8	13-1/8	13-1/8	13-1/8	13-1/8	13-1/8
Overall Dimensions (in./ L x W x H)	96 x 44 x 66	115 x 44 x 66	96 x 44 x 66	115 x 44 x 66	136 x 44 x 66	136 x 45 x 71
Motor	7-1/2HP, 230/460V, 3Ph, Prewired 230V	7-1/2HP, 230/460V, 3Ph, Prewired 230V	7-1/2HP, 230/460V, 3Ph, Prewired 230V	7-1/2HP, 230/460V, 3Ph, Prewired 230V	7-1/2HP, 230/460V, 3Ph, Prewired 230V	10HP, 230/460V, 3Ph, Prewired 230V
Net Weight (lbs.)	5,475	5,795	5,980	6,245	6,590	6,933



Attractive Chrome Control Levers, Dials and Knobs Complete this Package

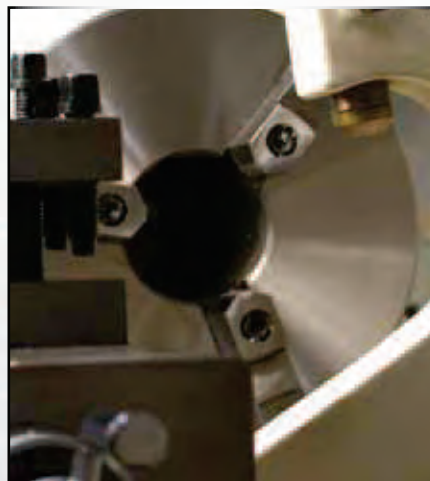

Large 3-1/8" Spindle Bore



Every JET ZX Lathe Comes with a Four-Way Tool Post



# CL-1640ZX-CNC LATHE WITH ANILAM 4200T CONTROL

## FEATURES

- Anilam 4200T with 12.1 TFT Flat Screen CNC Control
- Dual electronic handwheels for manual control
- Hardened and precision ground bed ways
- High alloy gears hardened, ground and honed
- 3-Bearing spindle support
- Automatic homing
- Easy access chip removal
- 4 Station Programmable Turret
- Automatic lubrication system
- Coolant system with 5.5 gallon coolant tank
- Teach In Mode
- 255 Pairs of Tool Offsets
- Rigid Tapping is Standard
- Turcite B on carriage sliding surfaces

## STANDARD EQUIPMENT

- Tool box and tools
- Fully enclosed Cabinet
- 10" 3-jaw chuck
- 16" Face plate
- Work light

**NEW!**



**JET**





### MANUAL MODE:

In manual mode, the lathe can be operated just as simply if it had been a conventional lathe. Up to two electronic hand-wheels can be connected to run the axes. In addition, the 4200T provides a wealth of data and many useful features, for example constant surface speed (CSS).



### SEMI-AUTOMATIC MODE:

The dual hand-wheel mode allows the machinist to cut in perfect arcs, tapers and chamfers. As only one hand-wheel is cranked, the 4200T will precisely control both axes to produce the desired shape.

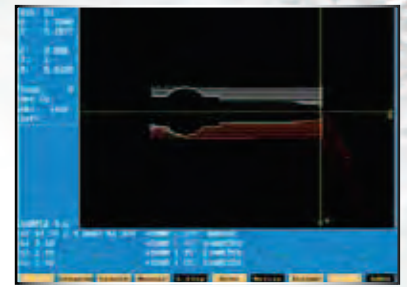

### AUTOMATIC MODE:

During automatic operation, the 4200T will control everything from start to finish. The machinist has several options on how to generate the program and some very powerful programming tools are available.



STOCK NUMBER	320930
Model Number	CL-1640ZX-CNC
Swing over Bed (in.)	16
Swing Through Gap (in.)	25-7/8
Distance Between Centers (in.)	40
Spindle Bore (in.)	3-1/8
Spindle Mount	D1-8
Spindle Taper (w/ Sleeve)	MT-7 (MT-5)
Range of Spindle Speeds (RPM)	80 - 2000
Rapid Feed, X-Axis (in./min.)	394
Rapid Feed, Y-Axis (in./min.)	315
Max Tool Size (in.)	1 x 1
Cross Slide Travel (in.)	9
Carriage Travel (in.)	35
Tailstock Spindle Travel (in.)	6
Taper in Tailstock Spindle	MT-4
Steady Rest Capacity (in.)	3/8 to 7
Width of Bed (in.)	13-1/4
Motor	10HP, 230V, 3Ph
Net Weight (lbs.)	5,680

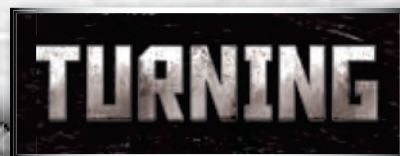



# TURNING ACCESSORIES

**90**  
DAY  
WARRANTY

## TOOL POST SETS

SERIES 200, 300 & 400 WEDGE TYPE POST SETS

- #1 Boring & Facing
- #2 Boring, Turning & Facing
- #4 Boring, Heavy Duty
- #7 Universal Parting Blade
- #10 Knurling, Facing & Turning
- Working parts hardened and ground
- Maximum rigidity for chatter-free performance
- Holders fit ALORIS and YUASA tool posts
- Increases productivity of all lathe operations
- Completely sealed for maintenance free operation
- Change tools in seconds

STOCK NUMBER	650295	650300	650305
Series	200 (BXA)	300	400 (CA)
Fits Swing Lathe Size (in.)	10 - 15	10 - 18	14 - 20
Net Weight (lbs.)	6	6	7



650300

## 5-C COLLET SETS & RACKS

- Precision hardened and ground
- C Collets for use on lathes
- Premium collets with 0.0005mm T.I.R.

STOCK NUMBER	DESCRIPTION
650014	CS-5C 16 pcs 5-C collet set 1/8" to 1 1/16" by 1/16th
650015	18 pc Premium 5C collet set 1/16" to 1-1/8" by 16th with Metal Rack
650016	35 pc Premium 5C collet set 1/16" to 1-1/8" by 32nds with Metal Rack
650017	Metal collet rack holds 30 5C collets
650018	Metal collet rack holds 72 5C collets



650014

650015

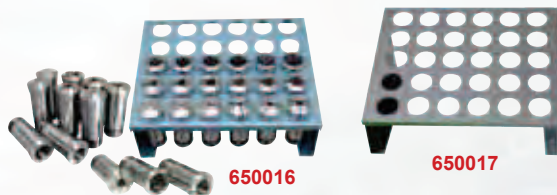

650016

650017

## COOLANT SYSTEM

- For use with BDB-1340, GHB-1340 & GHB 1440
- 1/8 HP, 115V 3 gallon per minute flow rate
- Requires drilling of chip pan

STOCK NUMBER	DESCRIPTION
321444	CP-13BD, Coolant Pump Kit for 321357A and 321360A



**JET**





## TOOLING KITS

22 & 23 PIECE SETS FOR JET LATHES

### 660200 Kit Includes

- Three double ended boring bars
- Parting tool holder
- Adjustable turning tool holder
- Revolving knurling tool with three pairs of knurls
- Half dead center
- Carbide tipped dead center
- Heavy-duty live center
- Cut off tool
- Eight HSS tool bits
- Four hex key wrenches
- Works with 13" and 14" W Series and Bench Series Lathes

### 660210 Kit Includes

- Three double ended boring bars
- Parting tool holder
- Adjustable turning tool holder
- Revolving knurling tool with three pairs of knurls
- Half dead center
- Carbide tipped dead center
- Heavy-duty live center
- Cut off tool
- Eight HSS tool bits
- Four hex key wrenches
- Works with all ZX Series Lathes



STOCK NUMBER	DESCRIPTION
660200	22-piece Turning Tool Kit for 13" & 14" W Series & Bench Series Lathes
660210	23-piece Turning Tool Kit for all ZX Series Lathes

## TAPER ATTACHMENTS

- Specially designed for each model
- 10° inclusive cutting capacity
- Mounts to predrilled and tapped holes
- Factory installation available

STOCK NUMBER	MODEL NUMBER	MAX. TAPER LENGTH (IN.) AT 10° ANGLE
321442	BDB-1340A	10
321442	GHB-1340A	10
321520	All W models	10-5/8
321291	All ZX models	18

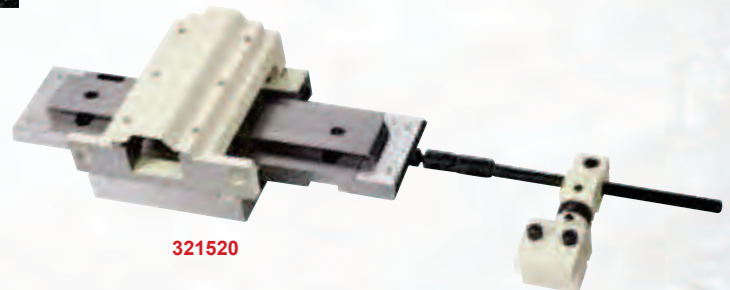

## GOLLET CLOSER

- Specially designed for each model
- Precision ground components
- Uses 5C collets
- Rear mounted lever action
- Some drilling and other modification may be required

STOCK NUMBER	MODEL NUMBER
321515A	BDB-1340A
321514A	GHB-1340A
321519	All W models
321292	All ZX models





# TURNING PACKAGES :: BENCH LATHES

STOCK NUMBER	321360A	321357A	321359A
Model Number	BDB-1340A	GHB-1340A	GHB-1440A
Swing Over Bed (in.)	13	13	14
Distance between Centers (in.)	40	40	40
Spindle Bore (in.)	1-3/8	1-3/8	1-3/8
Motor	2HP, 1Ph, 230V	2HP, 1Ph, 230V	2HP, 1Ph, 230V

## LATHE INCLUDED IN ALL PACKAGE NUMBERS LISTED BELOW

Taper Attachment		321119	321157
Collet Closer		321124	
Taper Attachment & Collet Closer		321129	321159
Acu-Rite VUE 2 Axis DRO	321110	321103	321158
Acu-Rite VUE 2 Axis DRO & Collet Closer		321102	321107
Acu-Rite VUE 2 Axis DRO, Taper Attachment & Collet Closer		321226	
Acu-Rite VUE 3- Axis DRO (Knee)			
Acu-Rite 200S 2 Axis DRO	321121	321122	
Acu-Rite 200S 2 Axis DRO & Taper Attachment		321123	
Acu-Rite 200S 2 Axis DRO & Collet Closer		321125	
Newall DP700 2-Axis DRO	321130	321131	
Newall DP700 2-Axis DRO & Taper Attachment		321115	
Newall DP700 2-Axis DRO & Collet Closer		321581	
Newall DP700 2-Axis DRO, Collet Closer & Taper Attachment		321104	





# TURNING PACKAGES :: ENGINE LATHES

STOCK NUMBER	321810	321820	321830	321840
<b>Model Number</b>	GH-1340W-1	GH-1340W-3	GH-1440W-1	GH-1440W-3
<b>Swing Over Bed (in.)</b>	13	13	14	14
<b>Distance between Centers (in.)</b>	40	40	40	40
<b>Spindle Bore (in.)</b>	1-1/2	1-1/2	1-1/2	1-1/2
<b>Motor</b>	3HP, 1Ph, 230V	3HP, 3Ph, 230/460V	3HP, 1Ph, 230V	3HP, 3Ph, 230/460V
<b>LATHE INCLUDED IN ALL PACKAGE NUMBERS LISTED BELOW</b>				
<b>Taper Attachment</b>	321521	321516	321517	321522
<b>Collet Closer</b>	321151	321555	321518	321729
<b>Taper Attachment &amp; Collet Closer</b>	321160	321577	321500	
<b>Acu-Rite VUE 2 Axis DRO</b>	321401	321402	321403	321404
<b>Acu-Rite VUE 2 Axis DRO &amp; Taper Attachment</b>	321425	321172	321175	321176
<b>Acu-Rite VUE 2 Axis DRO &amp; Collet Closer</b>	321146	321170	321173	321406
<b>Acu-Rite 200S 2 Axis DRO</b>	321532	321459	321549	321533
<b>Acu-Rite 200S 2 Axis DRO &amp; Taper Attachment</b>	321128	321447	321550	321563
<b>Acu-Rite 200S 2 Axis DRO &amp; Collet Closer</b>	321526	321562	321548	321524
<b>Acu-Rite 200S 2 Axis DRO, Taper Attachment &amp; Collet Closer</b>	321538	321546	321564	321572
<b>Newall DP700 2-Axis DRO</b>	321132	321133	321134	321135
<b>Newall DP700 2-Axis DRO &amp; Taper Attachment</b>	321154	321143	321145	321144
<b>Newall DP700 2-Axis DRO &amp; Collet Closer</b>	321142	321537	321558	320536
<b>Newall DP700 2-Axis DRO, Collet Closer &amp; Taper Attachment</b>		321547		
<b>Anilam 411 DRO</b>	322401	321545		321540
<b>Anilam 411 DRO &amp; Collet Closer</b>				321542
<b>Anilam 411 DRO Taper Attachment &amp; Collet Closer</b>	321126			



# TURNING PACKAGES :: LARGE SPINDLE BORE

STOCK NUMBER	321910	321920	321930	321940
Model Number	GH-1440ZX	GH-1460ZX	GH-1640ZX	GH-1660ZX
Swing Over Bed (in.)	14	14	16	16
Distance between Centers (in.)	40	60	40	60
Spindle Bore (in.)	3-1/8	3-1/8	3-1/8	3-1/8
Motor	7-1/2HP, 3Ph, 230/460V	7-1/2HP, 3Ph, 230/460V	7-1/2HP, 3Ph, 230/460V	7-1/2HP, 3Ph, 230/460V
<b>LATHE INCLUDED IN ALL PACKAGE NUMBERS LISTED BELOW</b>				
Taper Attachment	321467	321480	321474	321477
Collet Closer	321531		321439	321573
Taper Attachment & Collet Closer				321544
Acu-Rite 200S 2 Axis DRO	321469	321478	321475	321455
Acu-Rite 200S 2 Axis DRO & Taper Attachment	321507	321503	321508	321543
Acu-Rite 200S 2 Axis DRO & Collet Closer	321501	321490	321495	321440
Acu-Rite 200S 2 Axis DRO, Taper Attachment & Collet Closer	321569	321509		321576
Acu-Rite 200S 3- Axis DRO			321525	321530
Acu-Rite 300S 2 Axis DRO	321301	321311	321381	321388
Acu-Rite 300S 2 Axis DRO & Taper Attachment	321303	321312	321382	321389
Acu-Rite 300S 2 Axis DRO & Collet Closer	321304	321315	321383	321390
Acu-Rite 300S 2 Axis DRO, Taper Attachment & Collet Closer	321302	321313		321391
Newall DP700 2-Axis DRO	321470	321137	321138	321139
Newall DP700 2-Axis DRO & Taper Attachment	321570		321148	321529
Newall DP700 2-Axis DRO & Collet Closer	321441		321494	321527
Newall DP700 2-Axis DRO, Collet Closer & Taper Attachment	321498		321147	321502
Newall DP900 2-Axis DRO	321306	321314	321384	321392
Newall DP900 2-Axis DRO & Taper Attachment	321305		321385	321393
Newall DP900 2-Axis DRO & Collet Closer	321307	321585	321380	321394
Newall DP900 2-Axis DRO, Taper Attachment & Collet Closer	321308		321386	321387





# TURNING PACKAGES :: LARGE SPINDLE BORE

STOCK NUMBER	321950	321960	321970	321980
Model Number	GH-1840ZX	GH-1860ZX	GH-1880ZX	GH-2280ZX
Swing Over Bed (in.)	18	18	18	22
Distance between Centers (in.)	40	60	80	80
Spindle Bore (in.)	3-1/8	3-1/8	3-1/8	3-1/8
Motor	7-1/2HP, 3Ph, 230/460V	7-1/2HP, 3Ph, 230/460V	7-1/2HP, 3Ph, 230/460V	10HP, 3ph, 230/460V

## LATHE INCLUDED IN ALL PACKAGE NUMBERS LISTED BELOW

Taper Attachment	321466	321463	321486	321565
Collet Closer				321496
Taper Attachment & Collet Closer		321961	322486	321575
Acu-Rite 200S 2 Axis DRO	321481	321484	321487	321879
Acu-Rite 200S 2 Axis DRO & Taper Attachment	321483	321504	321560	321567
Acu-Rite 200S 2 Axis DRO & Collet Closer	321448	321491	321492	321566
Acu-Rite 200S 2 Axis DRO, Taper Attachment & Collet Closer	321454	321505	321493	321568
Acu-Rite 300S 2 Axis DRO	321415	321590	321595	321610
Acu-Rite 300S 2 Axis DRO & Taper Attachment	321418	321591	321597	321612
Acu-Rite 300S 2 Axis DRO & Collet Closer	321416	321592	321598	321613
Acu-Rite 300S 2 Axis DRO, Taper Attachment & Collet Closer	321417	321593	321599	321615
Newall DP700 2-Axis DRO	321650	321485	321488	321880
Newall DP700 2-Axis DRO & Taper Attachment		321452	321571	321881
Newall DP700 2-Axis DRO & Collet Closer	321655			
Newall DP700 2-Axis DRO, Collet Closer & Taper Attachment	321657	321557		321579
Newall DP900 2-Axis DRO	321419	321594	321596	
Newall DP900 2-Axis DRO & Taper Attachment			321600	321614



# DIGITAL READOUTS FOR TURNING APPLICATIONS

The days of inaccurate measurement conversions due to math errors and productivity lulls caused by lost data are over. JET offers a variety of Digital Readout packages for JET Lathes designed to keep track of position, provide prompt feedback and messaging, and quick configuration of machine features. Die-cast metal construction ensures unit reliability and displays are very easy to read. Add the right Digital Readout to the JET Lathes in your shop.



## ANILAM DIGITAL READOUTS

The ANILAM Wizard 411 is a simple cost effective entry level solution for manual machine tool applications. The Wizard 411 features exclusive LCD display screen technology and versatile software to accommodate milling, turning or grinding applications. The ANILAM Wizard 411 is the first readout in the industry to display full text on a crystal clear LCD display. Plus, a content-sensitive help function assists you right on screen.

### WIZARD 411 Features/Technical Data

- 1, 2 or 3-axis 5.7" transmissive LCD display
- Job Clock
- Feed rate display
- Multiple language supports
- Zero reset capability
- Instant radius/diameter conversion
- Absolute/incremental display
- Instant inch/mm conversion
- Conversational message prompts
- Linear error compensation
- Die-cast enclosure

### Turning Specific Features

Lock axis feature—used in conjunction with tool offsetting, lets you establish tool offsets with the tool

### Precision Glass Scales

With more than one million scales in use today, ANILAM precision glass scales withstand the elements of contamination found in even the harshest machine shop environments. As a result, our precision glass scales resist changes in size, shape or density due to temperature and humidity variations. This stability provides exceptional accuracy down to  $\pm 1.5\mu\text{m}$  (.00006"), resulting in tighter workpiece tolerances.

# ANILAM®



# JET

052



# ACU-RITE DIGITAL READOUTS FOR TURNING

## VUE

The Acu-Rite VUE is a cost-effective, entry-level solution for manual machine tool applications. With our innovative LCD display screen technology and versatile software to accommodate milling, turning or grinding applications the VUE is everything you need at a price you can afford.

### Common Features

- 1, 2 or 3 axis 5.7" Transmissive LCD display
- Job Clock
- Feed Rate Display
- Multiple Language Support
- Absolute/Incremental
- Near-Zero Warning
- Help Function
- 16 Tool Offsets/Diameter
- Preset and zero reset
- 4 Function Calculator/Trig Calculator
- Instant Inch/mm conversion
- 200mm Fixed Reference Marks

### Turning Specific Features

- Lock axis feature—used in conjunction with tool offsetting, lets you establish tool offsets with the tool under load, resulting in reduced tool deflection.
- Instant radius/diameter conversion

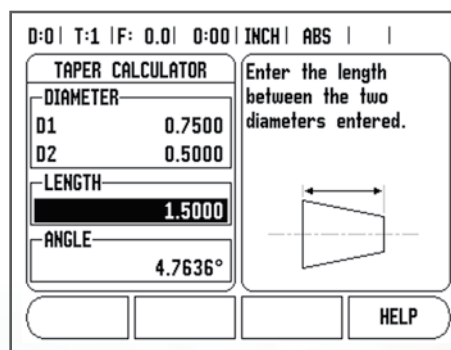

## 200S

As the industry standard in digital readout systems, the Acu-Rite 200S offers state-of-the-art features for milling, turning and grinding applications.

### Common Features

- 2 or 3 axis 5.7" Transmissive LCD display
- Job Clock
- Feed Rate Display
- Multiple Language Support
- Absolute/Incremental
- Near-Zero Warning
- Help Function
- 16 Tool Offsets/Diameter
- Preset and zero reset
- 4 Function Calculator/Trig Calculator
- Instant Inch/mm conversion
- Position-Trac™ Home Reference

### Turning Specific Features

- Lock axis feature
- Instant radius/diameter conversion
- Taper Calculator
- CSS (option)

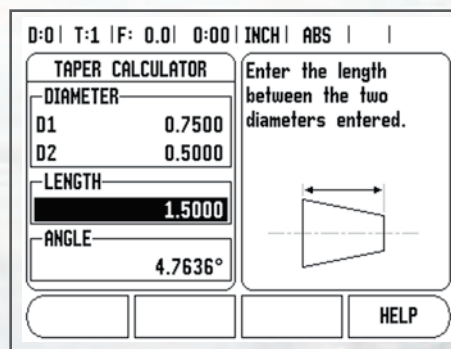

# TURNING



# ACU-RITE DIGITAL READOUTS FOR TURNING

## 300S

The Acu-Rite 300S is a fully programmable 4 axis readout system, now available with a full color display. With the capability to store and create a library of programs the 300S is everything you need to create, edit and execute programs on your manual machine tool.

### Common Features

- 2, 3 or 4 axis 5.7" Full Color Display
- Multiple program names with numerous steps
- Multiple display views
- Job Clock
- Feed Rate Display
- Multiple Language Support
- Absolute/Incremental
- Near-Zero Warning
- Help Function
- 16 Tool Offsets/Diameter
- Preset and zero reset
- 4 Function Calculator/Trig Calculator
- Instant Inch/mm conversion
- Position-Trac™ Home Reference

### Turning Specific Features

- Lock axis feature
- Instant radius/diameter conversion
- Taper Calculator

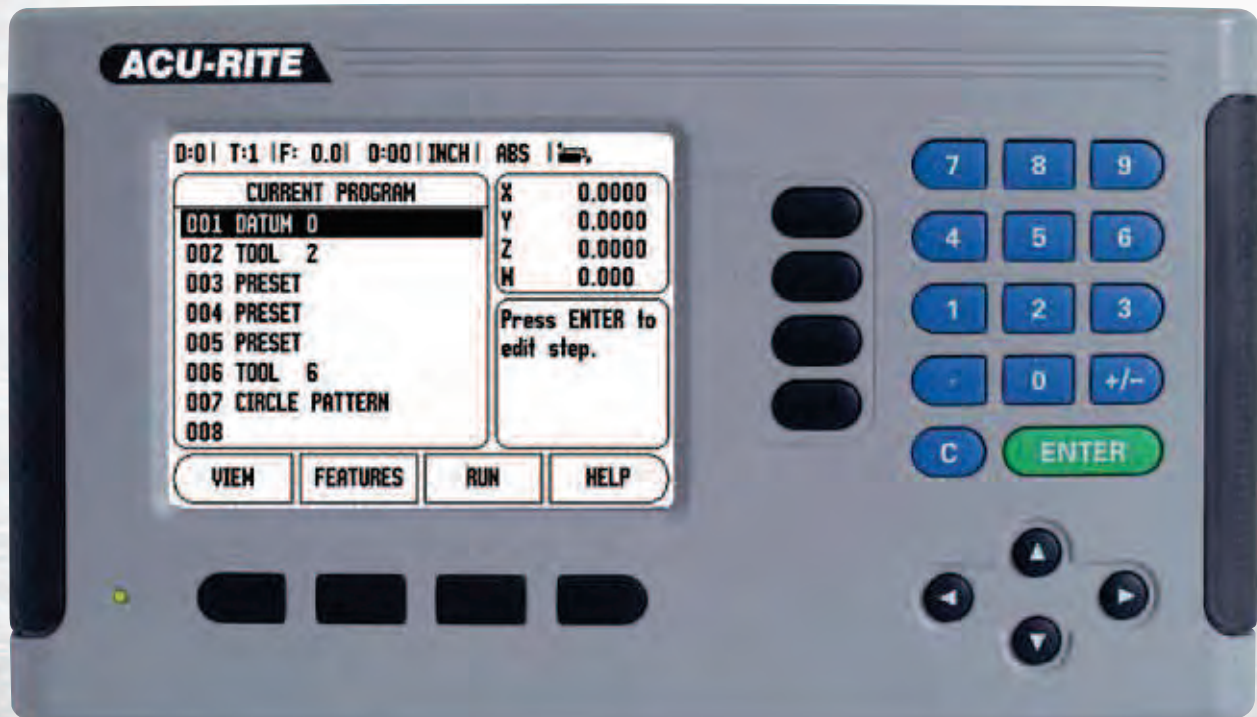
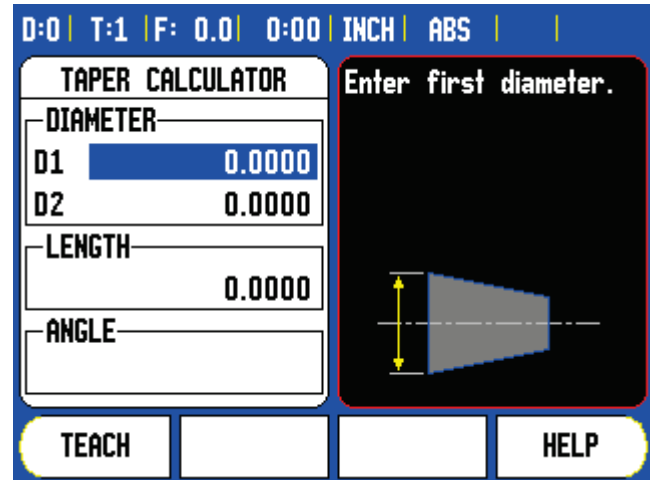

**JET**



# NEWALL DIGITAL READOUTS FOR TURNING

## DP700

The DP700 is the latest in Newall's line of a powerful and intuitive DROs. The unit is housed in a rugged, ergonomically designed casting. The DRO features all of the essential functions for milling, boring, turning, grinding, and general machining operations.

### Common Features

- Clean, Crisp, Easy to Read, LEDs
- Intuitive Message Window
- Long Life Membrane Keypad
- Solid cast construction
- Safe, Low Voltage Power Supply (UL)
- Panel Mount Version Available
- Feed Rate Display
- Bolt Hole Circle Routine
- Line Hole Routine
- Arc Contouring
- Programmable Memory/Teach
- Polar Coordinates
- Line Hole Calculator
- Tool Offsets
- Taper Calculations
- Axis Vectoring/Summing
- Linear and Segmented Error Comp.
- Undo
- RS232 Output
- Languages: English, French, German, Spanish, Italian, Turkish, Czech, Russian, Portuguese, Danish

The DP700 is compatible with Newall's Spherosyn and Microsyn encoders which withstand the harshest shop conditions.



## DP900

Setting new performance standards, the DP900 integrates the latest innovations in electronic design, housed in a rugged die-cast chassis. The feather-touch keypad ensures long life and stability throughout the rugged shop environment. The DRO offers flexible features tailored for milling or turning applications. Plus, with the use of a touch probe, part inspection calculations can be performed without removing the part from the machine.

### Common Features

- Rugged Die-Cast Chassis
- Feather-Touch, Cap-Sense Keypad
- 5.7" QVGA Blue STN with CCFL Backlight
- 2, 3, or 4 Axis with Optional Rotary Axis
- Graphical Tool Path Verification
- Customized Canned Cycles
- Remote Storage via USB Port
- CMM / Inspection Functions with Probe Capabilities
- Feed Rate Display
- Polar Co-ordinate Readings
- Touch Probe Input
- Teach Mode with Graphics

### Turning Specific Features

- Taper Calculation
- Vectoring
- Tool Offsets (99)
- Axis Summing
- Radius / Diameter Readings





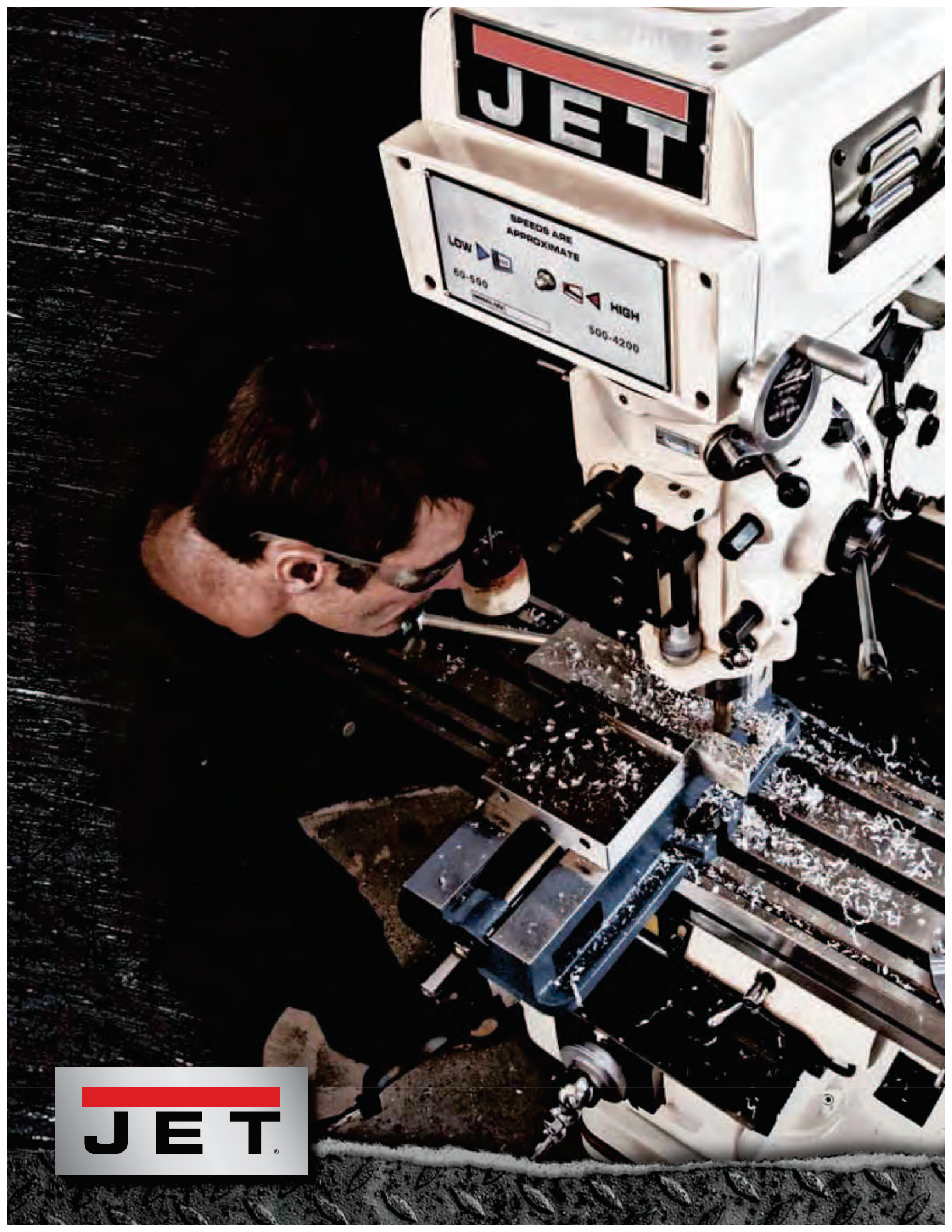





# MILLING

JET Milling machines and components provide consistent quality and performance year after year. Precision-built and designed to last, the complete line of JET Step Pulley, Variable Speed and CNC Mills allows your shop greater flexibility to meet the needs of any job. Professional manuals get you up and running, and every JET machine is backed by our industry-leading TWO-year warranty.

**PRECISION-  
BUILT AND  
DESIGNED  
TO LAST**



# VERTICAL MILLING MACHINES

With precision bored and honed milling heads JET Vertical Milling Machines perform slot and keyway cutting, planing, drilling, diesinking, rebating and routing with surgical accuracy. Models include tilting heads, high-precision spindle bearings, large diameter chrome quill and other standard features. JET Milling Machines are accurate and reliable, and perfect for your metal shop or commercial plant.



## JET HOBBY MILL DRILL

### FEATURES

- Cast iron design for vibration free operation
- Powerful 150W DC-motor
- Electronic variable speed with 2-step gear box
- Left hand spindle rotation allows for tapping
- 45° right/left tilt table/column for flexible work
- Compound table precision machined with adjustable dovetail guides
- Micro adjustable spindle downfeed

STOCK NUMBER	350200
Model Number	JHM-610
Spindle Taper	MT-2/ M10
Max Distance Spindle to Table (in.)	8-1/4
Distance Spindle to Column (in.)	5-1/2
Drilling Capacity (in.)	3/8
Face Mill Capacity (in.)	3/4
End Mill Capacity (in.)	3/8
Range of Spindle Speeds (RPM)	100 - 1,000 / 200 - 2,000
Table Size (in.)	5-3/4 x 9-1/2
Motor	150W DC Motor
Net Weight (lbs.)	88

### ACCESSORIES

### STOCK NUMBER

Stand	350213
MT-2 Collets (6 pc. - 1/8, 5/32, 3/16, 1/4, 5/16, 3/8)	350203
Vise	350204
Clamping Kit (24 pc.)	350205
Milling Arbor	350206
MT-2 Boring Bar	350207
Quick Vise with Swivel Base	350208
HSS Endmills (6 pc. - 1/8, 5/32, 3/16, 1/4, 5/16, 3/8)	350209



350231  
Optional Stand

**JET**



# MILLING / DRILLING MACHINES

## FEATURES

- One-piece cast iron column for added support
- Belt cover – quick slide latch allows faster belt adjustment to change spindle speeds
- Base – taper allows for easier clean-up
- Larger hand wheel knobs
- UL Listed motor
- Extra large worktable
- Heavy-duty tapered roller bearings support the spindle, resulting in greater tolerance and more accurate drilling depth
- New positive quick-stop knob and easy-to-read internal depth gauge (external on JMD-15)

## STANDARD EQUIPMENT

- Worklamp
- Adjustable carbide facemill
- Drill press angle vise
- 1/2" drill chuck, chuck arbor
- Draw bar



**350018**  
Shown with  
Optional Stand



**660012**

**350045**

STOCK NUMBER	350017	350018	350020
Model Number	JMD-15	JMD-18	JMD-18PFN
Drilling Capacity (in.)	1	1-1/4	1-1/4
Face Mill Capacity (in.)	2-1/2	3	3
End Mill Capacity (in.)	1/2	3/4	3/4
Swing (in.)	14-1/2	15-7/8	15-7/8
Max Distance Spindle to Table (in.)	15	18	26
Spindle Taper	R-8	R-8	R-8
Spindle Travel Manual (in.)	3-1/2	5	5
Spindle Travel Auto (in.)	-	-	4-1/4
Quill Diameter (in.)	2-7/16	3	3
Column Diameter (in.)	3-5/8	4-1/2	4-1/2
Number of Spindle Speeds	12	12	12
Range of Spindle Speeds (RPM)	110 - 2,580	150 - 3,000	150 - 3,000
Max. Table Travel (in.)	14	20-1/2	20-1/2
Cross Travel (in.)	5-1/2	6-1/2	6-1/2
Working Surface of Table (in.)	7-1/2 x 23	9-1/2 x 32-1/4	9-1/2 x 32-1/4
T-Slots, Number and Size (in.)	4 and 9/16	4 and 5/8	4 and 5/8
T-Slot Centers (in.)	1-13/16	1-13/16	1-13/16
Base Dimensions (in.)	12-1/2 x 19-3/4	15-3/4 x 23-3/4	15-3/4 x 23-3/4
Motor (UL Listed)	1HP, 1Ph, 115/230V Prewired 115V	2HP, 1Ph, 230V Only	2HP, 1Ph, 230V Only
Overall Dimensions (in./ L x W x H)	38 x 37-1/2 x 42	47 x 40 x 51	47 x 40 x 51
Net Weight (lbs.)	370	580	600

MILL / DRILL PACKAGES	STOCK NUMBER
JMD-18 Mill/Drill w/ANILAM 411 DRO	350401
JMD-18PFN Mill/Drill w/ANILAM 411	350402

OPTIONAL EQUIPMENT	STOCK NUMBER
Stand with Enclosed Shelf	350045
Powerfeed (JMD-18, 18PF Only)	350082
Clamping Kit	660012



# STEP PULLEY MILLING MACHINE - JVM-836-1 / 3

## FEATURES

- Precision bored and honed milling head
- Large diameter quill is chromed
- High precision spindle bearings
- Over 10" of front to back ram travel
- Locks on all movable surfaces
- Hardened and ground precision table
- Head tilts left or right
- Graduated scale on column
- Precision ground dovetail ways

## STANDARD EQUIPMENT

- One-shot lubrication system
- Way Covers
- Draw bar
- Tool box and tools

**2**  
YEAR  
WARRANTY



690038

STOCK NUMBER	690036	690038
Model Number	JVM-836-1	JVM-836-3
Table Size (in.)	7-7/8 x 35-3/4	7-7/8 x 35-3/4
Spindle Taper	R-8	R-8
Quill Diameter (in.)	3-3/8	3-3/8
Number of Spindle Speeds	5	10
Range of Spindle Speeds (RPM)	240 - 1,550	120 - 1,550
Spindle Travel (in.)	5	5
Head Movement (deg.)	90° R & L	90° R & L
Max Distance Spindle to Table (in.)	13-3/4	13-3/4
Distance Spindle to Column (max./in.)	15-3/4	15-3/4
Distance Spindle to Column (min./in.)	5-1/4	5-1/4
Collet Capacity	1/8 - 7/8	1/8 - 7/8
Table Longitudinal Travel (in.)	22-1/4	22-1/4
Table Cross Travel (in.)	9-1/2	9-1/2
T-Slots Number and Size (in.)	3 and 5/8	3 and 5/8
T-Slot Centers (in.)	2-1/2	2-1/2
Work Table Weight Capacity (lbs.)	500	500
Travel of Knee (in.)	14	14
Travel of Ram (in.)	10-1/2	10-1/2
Motor	1-1/2HP, 115/230V, 1Ph, Prewired 115V	1-1/2HP, 230V Only, 3Ph
Overall Dimensions (in./ L x W x H)	55 x 52 x 78	55 x 52 x 78
Net Weight (lbs.)	1,617	1,610

**JET**

060



# STEP PULLEY MILLING MACHINES - JTM-1 / 2

## FEATURES

- Meehanite casting
- Precision bored and honed milling head
- Large diameter quill is chromed
- High precision Class 7 spindle bearings
- Spindle head is internally cooled
- Satin chrome finished dials
- Heavy-duty splined motor drive
- One-piece quill pinion and shaft
- Three-stage power downfeed with automatic stop
- Heavy-duty spindle brake
- Precision hardened and ground ways
- Precision ground table
- Adjustable gibs throughout
- Internal coolant tank built into base for use with coolant system (Coolant pump not included)
- Tolerance test sheet included

## STANDARD EQUIPMENT

- One-shot lubrication system
- Way covers
- Draw bar
- Tool box with tools

**2**  
YEAR  
WARRANTY



690082

STOCK NUMBER	690082	690089
Model Number	JTM-1	JTM-2
Table Size (in.)	9 x 42	9 x 42
Spindle Taper	R-8	R-8
Quill Diameter (in.)	3-3/8	3-3/8
Number of Spindle Speeds	16	8
Range of Spindle Speeds (RPM)	80 - 5,440	80 - 2,720
Quill Down Feed Rates (IPR)	.0015 - .003 - .006	.0015 - .003 - .006
Spindle Travel (in.)	5	5
Head Movement (deg.)	90° R & L, 45° F & B	90° R & L, 45° F & B
Max Distance Spindle to Table (in.)	17-1/2	17-1/2
Distance Spindle to Column (max./in.)	19	19
Distance Spindle to Column (min./in.)	4-1/2	4-1/2
Collet Capacity	1/8 - 7/8	1/8 - 7/8
Table Longitudinal Travel (in.)	23-7/8	23-7/8
Table Cross Travel (in.)	12-1/2	12-1/2
T-Slots Number and Size (in.)	3 and 5/8	3 and 5/8
T-Slot Centers (in.)	2-1/2	2-1/2
Work Table Weight Capacity (lbs.)	550	550
Travel of Knee (in.)	14-1/2	14-1/2
Travel of Ram (in.)	13-3/8	13-3/8
Motor	2HP, 230V, 3Ph	2HP, 115/230V, 1Ph, Prewired 230V
Overall Dimensions (in./ L x W x H)	57 x 64 x 82	57 x 64 x 82
Net Weight (lbs.)	2,200	2,200



# VARIABLE SPEED MILLING MACHINES

Constructed through the Meehanite casting process, JET Variable Speed Milling Machines provide sound, consistent and reliable service and performance. Precision bored and honed milling heads ensure quality cuts, and the three-stage power downfeed with automatic stop makes the JET Variable Speed Milling Machines easy to use. Rugged construction, ease of use and precision results, hallmarks of JET Milling machines.



## VARIABLE SPEED VERTICAL MILLING MACHINE - JTM-4VS

### FEATURES

- Meehanite casting
- Precision bored and honed milling head
- Large diameter quill is chromed
- High precision Class 7 spindle bearings
- Chrome plated motor shaft with lower bearing support
- Spindle head is internally cooled
- Satin chrome finished dials
- Heavy-duty splined motor drive
- One-piece quill pinion and shaft
- Three-stage power downfeed with automatic stop
- Heavy-duty spindle brake
- Locks on all movable surfaces
- Precision hardened and ground ways and table

### STANDARD EQUIPMENT

- One-shot lubrication system
- Way covers
- Draw bar
- Tool box with tools



690182  
Shown with Optional DRO  
and Table Powerfeed

STOCK NUMBER	690180	690182
Model Number	JTM-4VS-1	JTM-4VS
Table Size (in.)	9 x 49	9 x 49
Spindle Taper	R-8	R-8
Quill Diameter (in.)	3-3/8	3-3/8
Number of Spindle Speeds	Variable	Variable
Range of Spindle Speeds (RPM)	60 - 4,200	60 - 4,200
Quill Down Feed Rates (per./rev./in.)	.0015 - .003 - .006	.0015 - .003 - .006
Spindle Travel (in.)	5	5
Head Movement (deg.)	90° R & L, 45° F & B	90° R & L, 45° F & B
Max Distance Spindle to Table (in.)	17-1/2	17-1/2
Distance Spindle to Column (max./in.)	19	19
Distance Spindle to Column (min./in.)	4-1/2	4-1/2
Collet Capacity	1/8 - 7/8	1/8 - 7/8
Table Longitudinal Travel (in.)	34	34
Table Cross Travel (in.)	12	12
T-Slots Number and Size (in.)	3 and 5/8	3 and 5/8
T-Slot Centers (in.)	2-1/2	2-1/2
Work Table Weight Capacity (lbs.)	660	660
Travel of Knee (in.)	14-1/2	14-1/2
Travel of Ram (in.)	13-3/8	13-3/8
Motor	2HP, 115/230V, 1Ph, Prewired 230V	3HP, 230/460V, 3Ph, Prewired 230V
Overall Dimensions (in./ L x W x H)	66 x 63 x 85	66 x 63 x 85
Net Weight (lbs.)	2,420	2,420



**JET**



# VARIABLE SPEED VERTICAL MILLING MACHINE - JTM-1050

## FEATURES

- Meehanite casting
- Hardened and ground table
- Chrome lead screws on X and Y axis
- Turcite B on X and Y axis
- Satin chrome finished dials
- Precision bored and honed milling head
- Large diameter quill is chromed
- High precision Class 7 spindle bearings
- Spindle head is internally cooled
- No Fuse breaker power connection
- Heavy-duty motor drive
- Chrome plated motor shaft with bearing support at end
- One-piece quill pinion and shaft

## STANDARD EQUIPMENT

- One-shot lubrication system
- Way covers
- Draw bar
- Tool box with tools

**2**  
YEAR  
WARRANTY



STOCK NUMBER	690050
Model Number	JTM-1050
Table Size (in.)	10 x 50
Spindle Taper	R-8
Quill Diameter (in.)	3-3/8
Number of Spindle Speeds	Variable
Range of Spindle Speeds (RPM)	70 - 3,800
Quill Down Feed Rates (IPR)	.0015 - .003 - .006
Spindle Travel (in.)	5
Head Movement (deg.)	90° R & L, 45° F & B
Max Distance Spindle to Table (in.)	19
Distance Spindle to Column (max./in.)	26
Distance Spindle to Column (min./in.)	5-1/2
Collet Capacity	1/8 - 7/8
Table Longitudinal Travel (in.)	30
Table Cross Travel (in.)	15-1/4
T-Slots Number and Size (in.)	3 and 5/8
T-Slot Centers (in.)	2-1/2
Work Table Weight Capacity (lbs.)	720
Travel of Knee (in.)	14-1/4
Travel of Ram (in.)	20-1/2
Motor	3HP, 230/460V, 3Ph, Prewired 230V
Overall Dimensions (in./ L x W x H)	96 x 78 x 88
Net Weight (lbs.)	2,900

**MILLING**



# ELECTRONIC VARIABLE SPEED VERTICAL MILLING MACHINE - JTM-1050EVS

## FEATURES

- Runs quieter and smoother than conventional variable speed head
- Low maintenance head has less moving parts
- No belt slippage allows more power at the spindle
- Meehanite casting
- Hardened and ground table
- Chrome lead screws on X and Y axis
- Turcite B on X axis and Y axis
- Large diameter quill is chromed
- High precision Class 7 spindle bearings
- No fuse breaker power connection
- Heavy-duty motor drive
- Chrome plated motor shaft with bearing support at end
- One-piece quill pinion and shaft

## STANDARD EQUIPMENT

- One-shot lubrication system
- Chip Pan
- Way Covers
- Draw bar
- Tool box and tools

**2**  
YEAR WARRANTY



690060

STOCK NUMBER	690060	690062
Model Number	JTM-1050EVS/230	JTM-1050EVS/460
Table Size (in.)	10 x 50	10 x 50
Spindle Taper	R-8	R-8
Quill Diameter (in.)	3-3/8	3-3/8
Number of Spindle Speeds	Variable	Variable
Range of Spindle Speeds (RPM)	10 - 3,600	10 - 3,600
Quill Down Feed Rates (IPR)	.0015 - .003 - .006	.0015 - .003 - .006
Spindle Travel (in.)	5	5
Head Movement (deg.)	90° R & L, 45° F & B	90° R & L, 45° F & B
Max Distance Spindle to Table (in.)	19	19
Distance Spindle to Column (max./in.)	26	26
Distance Spindle to Column (min./in.)	5-1/2	5-1/2
Collet Capacity	1/8 - 7/8	1/8 - 7/8
Table Longitudinal Travel (in.)	30	30
Table Cross Travel (in.)	15-1/4	15-1/4
T-Slots Number and Size (in.)	3 and 5/8	3 and 5/8
T-Slot Centers (in.)	2-1/2	2-1/2
Work Table Weight Capacity (lbs.)	720	720
Travel of Knee (in.)	14-1/4	14-1/4
Travel of Ram (in.)	20-1/2	20-1/2
Motor	3HP, 230V Only, 3Ph	3HP, 460V Only, 3Ph
Overall Dimensions (in./ L x W x H)	96 x 71 x 88	96 x 71 x 88
Net Weight (lbs.)	3,000	3,000

**JET**



# ELECTRONIC VARIABLE SPEED VERTICAL MILLING MACHINE - JTM-1054R / JTM-1055

**NEW!**

## FEATURES

- Meehanite casting
- Hardened and ground table certified to be 52C Rockwell hardness
- Chrome leadscrews on X and Y axis
- Box style ways on Y and Z axis
- Satin chrome finished dials
- Precision bored and honed milling head
- Large diameter quill is chromed
- High precision Class 7 spindle bearings
- Chrome plated motor shaft has lower bearing support
- Motor pulleys are ground to increase belt lift
- One-piece quill pinion and shaft

## STANDARD EQUIPMENT

- One-shot lubrication system
- Way covers
- Draw bar
- Tool box with tools

**2**  
YEAR WARRANTY



STOCK NUMBER	690053	690055
Model Number	JTM-1054R	JTM-1055
Table Size (in.)	10 x 54	10 x 54
Spindle Taper	R-8	NST #40
Quill Diameter (in.)	3-3/8	4-1/8
Number of Spindle Speeds	Variable	Variable
Range of Spindle Speeds (RPM)	80 - 3,800	80 - 3,800
Quill Down Feed Rates (IPR)	.0015 - .003 - .006	.0015 - .003 - .006
Spindle Travel (in.)	5	5
Head Movement (deg.)	90° R & L, 45° F & B	90° R & L
Max Distance Spindle to Table (in.)	20	20
Distance Spindle to Column (max./in.)	26	26
Distance Spindle to Column (min./in.)	5-1/2	5-1/2
Collet Capacity	1/8 - 7/8	1/8 - 7/8
Table Longitudinal Travel (in.)	32	32
Table Cross Travel (in.)	16	16
T-Slots Number and Size (in.)	3 and 5/8	3 and 5/8
T-Slot Centers (in.)	2-1/2	2-1/2
Work Table Weight Capacity (lbs.)	800	800
Travel of Knee (in.)	17-1/2	17-1/2
Travel of Ram (in.)	20-1/2	20-1/2
Motor	5HP, 230/460V, 3Ph, Prewired 230V	5HP, 230/460V, 3Ph, Prewired 230V
Overall Dimensions (in./ L x W x H)	108 x 80 x 80	108 x 80 x 92
Net Weight (lbs.)	3,300	3,000

690055

**MILLING**



# CNC VERTICAL MILLS

JET offers complete factory-installed CNC packages, with your choice of 2 or 3-axis CNC controls. The Computer Numerical Control system brings the added precision of digital automation to the process, and enables the operator greater control, effectiveness and efficiency. Meehanite casted JET Vertical Mills with CNC packages deliver accurate results with every cut.



## CNC VERTICAL MILLING MACHINE PACKAGES JTM-4VS

### FEATURES OF THE ACU-RITE MILLPWR® 2- OR 3-AXIS CONTROL

- Increased Productivity, mill more efficiently and effectively
- Bolthole Calculations, calculate bolthole patterns instantly
- Tool Offsets and Tool Library
- Jog Control, move quickly from one location to another—using one axis at a time or any two axes simultaneously
- 3-D Contouring, ability to import and run G-code files from CAD/CAM programs
- Mirror/Repeat/Rotate, easily manipulate part programs to save time and reduce program steps.
- Ease of use, convenient, user-friendly and multi-faceted
- 10" flat panel, vivid, color, LCD display to view immediate graphic feedback
- Menu-prompted Conversational programming, easily create part programs, edit, reverse, change, delete and copy/move steps—follow the menu prompts and let MILLPWR® do the rest
- Info Button, built-in help screens for content specific jobs
- Built-in Calculator, perform standard, trig and geometry calculations and transfer them directly into part programs

### FEATURES OF THE ANILAM 3000M 2- OR 3-AXIS CONTROL

- Utilizes a machinist's type language—easy conversational programing (No learning of G-Codes required)
- On-screen editing and help graphics, DXF and G-code conversion, which will save time and increase the productivity
- 12.1" active matrix TFT flat panel, color display
- Built-in calculator with three modes: basic math, right triangle and geometry, to provide Geometry assistance
- You can go from manual operations to CNC in seconds
- Heavy-Duty AC brushless servo motors
- Bolt hole patterns of any configuration can be easily produced
- The addition of DSP 2, an enhanced motion control system, means greater increases in productivity and much higher speed machining
- The Series 3000M is the most user-friendly conversational program
- Store programs on the hard drive for repeat jobs

**2**  
YEAR  
WARRANTY



#### OPTIONAL EQUIPMENT

#### STOCK NUMBER

52 pc. Clamping Kit	660012
6 pc. R-8 Collet Set (1/8" - 3/4" by 8th)	650132

Refer to pages 76-79 for Milling Accessories.

**JET**





# CNC VERTICAL MILLING MACHINE PACKAGES JTM-4VS

STOCK NUMBER	690908 & 690918	690905 & 690907
Model Number	JTM-4VSCNC	JTM-4VSCNC
2-Axis CNC	690908	690905
3-Axis CNC	690918	690907
CNC Package	ACU-RITE MILLPWR®	ANILAM 3000M
Table Size (in.)	9 x 49	9 x 49
Spindle Taper	R-8	R-8
Quill Diameter (in.)	3-3/8	3-3/8
Number of Spindle Speeds	Variable	Variable
Range of Spindle Speeds (RPM)	60 - 4,200	60 - 4,200
Quill Down Feed Rates (IPR)	.0015 - .003 - .006	.0015 - .003 - .006
Spindle Travel (in.)	5	5
Head Movement (deg.)	90° R & L, 45° F & B	90° R & L, 45° F & B
Max Distance Spindle to Table (in.)	17-1/2	17-1/2
Distance Spindle to Column (max./in.)	19	19
Distance Spindle to Column (min./in.)	4-1/2	4-1/2
Collet Capacity	1/8 - 7/8	1/8 - 7/8
Table Longitudinal Travel (in.)	34	34
Table Cross Travel (in.)	12	12
T-Slots Number and Size (in.)	3 and 5/8	3 and 5/8
T-Slot Centers (in.)	2-1/2	2-1/2
Work Table Weight Capacity (lbs.)	660	660
Travel of Knee (in.)	14-1/2	14-1/2
Travel of Ram (in.)	13-3/8	13-3/8
Motor	3HP, 230/460V, 3Ph, Prewired 230V	3HP, 230/460V, 3Ph, Prewired 230V
Overall Dimensions (in./ L x W x H)	66 x 63 x 85	66 x 63 x 85
Net Weight (lbs.)	2,420	2,420

## FEATURES OF THE JTM-4VS

- Meehanite casting
- Precision bored and honed milling head
- Large diameter quill is chromed
- High precision Class 7 spindle bearings
- Spindle head is internally cooled
- Satin chrome finished dials
- Heavy-duty splined motor drive
- One-piece quill pinion and shaft
- Three-stage power downfeed with automatic stop
- Heavy-duty spindle brake
- Chrome plated motor shaft with lower bearing support
- Adjustable gibs throughout
- Internal coolant tank built into base for use with coolant system (Coolant pump not included)
- Tolerance test sheet included

## STANDARD EQUIPMENT

- Locks on all movable surfaces
- Precision hardened and ground ways and table
- One-shot lubrication system
- Way covers
- Draw bar
- Tool box with tools



Precision Glass Scales to Provide Better Accuracy, Repeatability, Elimination of Backlash and Much More!

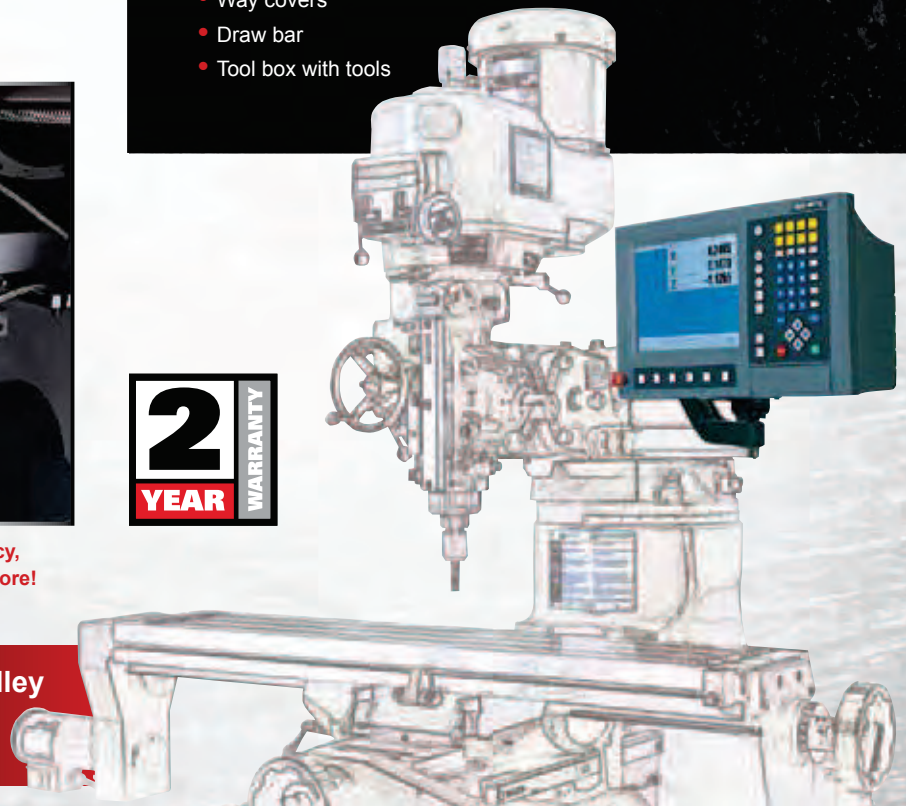

Packages also available in Step Pulley Mills—ask our customer relations associate for assistance.

# MILLING



# CNC ELECTRONIC VARIABLE SPEED VERTICAL MILLING MACHINE PACKAGES JTM-1050

## FEATURES OF THE ANILAM 3000M 2- OR 3-AXIS CONTROL

- Utilizes a machinist's type language—easy conversational programming (No learning of G-Codes required). The Series 3000M is the most user-friendly conversational program
- On-screen editing and help graphics, DXF and G-code conversion, which will save time and increase the productivity
- 12.1" active matrix TFT flat panel, color display
- Built-in calculator with three modes: basic math, right triangle and geometry, to provide Geometry assistance
- You can go from manual operations to CNC in seconds
- Heavy-Duty AC brushless servo motors
- Bolt hole patterns of any configuration can be easily produced
- The addition of DSP 2, an enhanced motion control system, means greater increases in productivity and much higher speed machining
- Store programs on the hard drive for repeat jobs

## FEATURES OF THE ACU-RITE MILLPWR® 2- OR 3-AXIS CONTROL

- Increased Productivity, mill more efficiently and effectively
- Bolthole Calculations, calculate bolthole patterns instantly
- Tool Offsets and Tool Library
- Jog Control, move quickly from one location to another—using one axis at a time or any two axes simultaneously
- 3-D Contouring, ability to import and run G-code files from CAD/CAM programs
- Mirror/Repeat/Rotate, easily manipulate part programs to save time and reduce program steps.
- Ease of use, convenient, user-friendly and multi-faceted
- 10" flat panel, vivid, color, LCD display to view immediate graphic feedback
- Menu-prompted Conversational programming, easily create part programs, edit, reverse, change, delete and copy/move steps—follow the menu prompts and let MILLPWR® do the rest
- Info Button, built-in help screens for content specific jobs
- Built-in Calculator, perform standard, trig and geometry calculations and transfer them directly into part programs
- Versatility, mill and program simultaneously
- 2- or 3-axis Control/ 3-axis Readout, significantly improves efficiency, productivity and profitability, may be used automatically or manually

OPTIONAL EQUIPMENT	STOCK NUMBER
--------------------	--------------

52 pc. Clamping Kit	660012
---------------------	--------

6 pc. R-8 Collet Set (1/8" - 3/4" by 8ths)	650132
---	--------

Refer to pages 76-79 for Milling Accessories.



The JET logo, featuring the word 'JET' in a bold, black, sans-serif font with a red horizontal bar above the 'E'.



# CNC VERTICAL MILLING MACHINE PACKAGES JTM-1050

## FEATURES OF THE JTM-1050

- Meehanite casting
- Precision bored and honed milling head
- Large diameter quill is chromed
- High precision Class 7 spindle bearings
- Spindle head is internally cooled
- Satin chrome finished dials
- Heavy-duty motor drive
- One-piece quill pinion and shaft
- Three-stage power downfeed with automatic stop
- Heavy-duty spindle brake
- Chrome plated motor shaft with lower bearing support at end
- Adjustable gibs throughout
- Internal coolant tank built into base for use with coolant system (Coolant pump not included)
- Tolerance test sheet included
- Locks on all movable surfaces
- Hardened and ground table

## STANDARD EQUIPMENT

- One-shot lubrication system
- Way covers
- Draw bar
- Tool box with tools
- Chrome lead screws on X and Y axis
- Turcite B on X and Y axis
- No fuse breaker power connection
- Hardened and ground square vertical knee ways and cross ways



STOCK NUMBER	690900 & 690910	690920 & 690921
Model Number	JTM-1050CNC	JTM-1050CNC
2-Axis CNC	690900	690620
3-Axis CNC	690910	690621
CNC Package	ACU-RITE MILLPWR®	ANILAM 3000M
Table Size (in.)	10 x 50	10 x 50
Spindle Taper	R-8	R-8
Quill Diameter (in.)	3-3/8	3-3/8
Number of Spindle Speeds	Variable	Variable
Range of Spindle Speeds (RPM)	70 - 3,800	70 - 3,800
Quill Down Feed Rates (IPR)	.0015 - .003 - .006	.0015 - .003 - .006
Spindle Travel (in.)	5	5
Head Movement (deg.)	90° R & L, 45° F & B	90° R & L, 45° F & B
Max Distance Spindle to Table (in.)	19	19
Distance Spindle to Column (max./in.)	26	26
Distance Spindle to Column (min./in.)	5-1/2	5-1/2
Collet Capacity	1/8 - 7/8	1/8 - 7/8
Table Longitudinal Travel (in.)	30	30
Table Cross Travel (in.)	15-1/4	15-1/4
T-Slots Number and Size (in.)	3 and 5/8	3 and 5/8
T-Slot Centers (in.)	2-1/2	2-1/2
Work Table Weight Capacity (lbs.)	720	720
Travel of Knee (in.)	14-1/4	14-1/4
Travel of Ram (in.)	20-1/2	20-1/2
Motor	3HP, 230/460V, 3Ph, Prewired 230V	3HP, 230/460V, 3Ph, Prewired 230V
Overall Dimensions (in./ L x W x H)	96 x 69 x 87	96 x 69 x 87
Net Weight (lbs.)	3,200	3,200

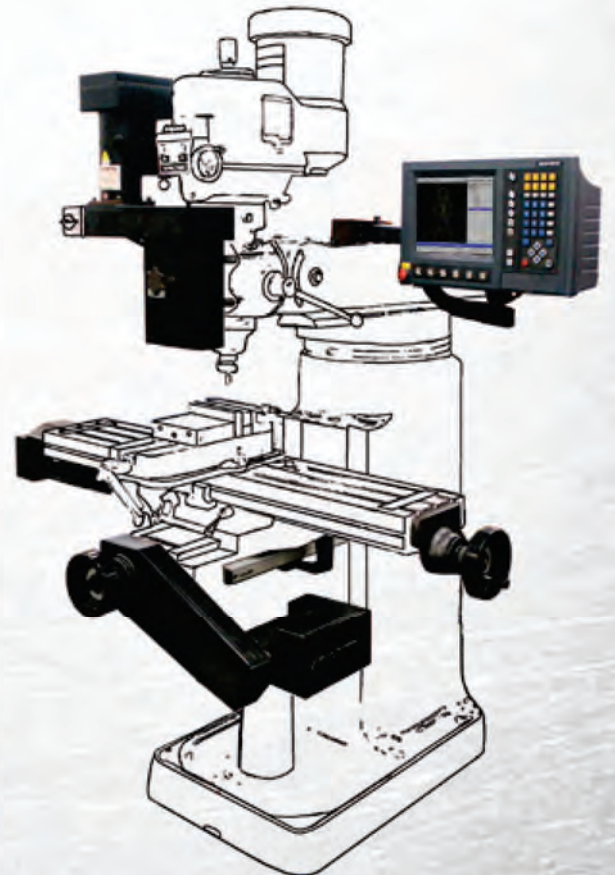

# MILLING



# CNC ELECTRONIC VARIABLE SPEED VERTICAL MILLING MACHINE PACKAGES JTM-1050EVS

## FEATURES OF THE ANILAM 3000M 2- OR 3-AXIS CONTROL

- Utilizes a machinist's type language—easy conversational programming (No learning of G-Codes required). The Series 3000M is the most user-friendly conversational program
- On-screen editing and help graphics, DXF and G-code conversion, which will save time and increase the productivity
- 12.1" active matrix TFT flat panel, color display
- Built-in calculator with three modes: basic math, right triangle and geometry, to provide geometry assistance
- You can go from manual operations to CNC in seconds
- Heavy-Duty AC brushless servo motors
- Bolt hole patterns of any configuration can be easily produced
- The addition of DSP 2, an enhanced motion control system, means greater increases in productivity and much higher speed machining
- Store programs on the hard drive for repeat jobs
- Provides all manual operations. Ideal for set up and teach modes and for machining the simplest parts
- 2-axis can easily be upgraded to a 3-axis at any time

## FEATURES OF THE ACU-RITE MILLPWR® 2- OR 3-AXIS CONTROL

- Increased Productivity, mill more efficiently and effectively
- Bolthole Calculations, calculate bolthole patterns instantly
- Tool Offsets and Tool Library
- Jog Control, move quickly from one location to another—using one axis at a time or any two axes simultaneously
- 3-D Contouring, ability to import and run G-code files from CAD/CAM programs
- Mirror/Repeat/Rotate, easily manipulate part programs to save time and reduce program steps.
- Ease of use, convenient, user-friendly and multi-faceted
- 10" flat panel, vivid, color, LCD display to view immediate graphic feedback
- Menu-prompted Conversational programming, easily create part programs, edit, reverse, change, delete and copy/move steps—follow the menu prompts and let MILLPWR® do the rest
- Info Button, built-in help screens for content specific jobs
- Built-in Calculator, perform standard, trig and geometry calculations and transfer them directly into part programs



OPTIONAL EQUIPMENT	STOCK NUMBER
52 pc. Clamping Kit	660012
6 pc. R-8 Collet Set (1/8" - 3/4" by 8ths)	650132

Refer to pages 76-79 for Milling Accessories.





# CNC ELECTRONIC VARIABLE SPEED VERTICAL MILLING MACHINE PACKAGES JTM-1050EVS



## FEATURES OF THE JTM-1050EVS

- Meehanite casting
- Runs quieter and smoother than conventional variable speed head
- Large diameter quill is chromed
- High precision Class 7 spindle bearings
- Low maintenance head has less moving parts
- No belt slippage allows more power at the spindle
- Heavy-duty motor drive
- One-piece quill pinion and shaft
- Heavy-duty spindle brake
- Adjustable gibs throughout

## STANDARD EQUIPMENT

- No fuse breaker power connection
- Hardened and ground table
- One-shot lubrication system
- Way covers
- Draw bar
- Tool box with tools
- Chrome lead screws on X and Y axis
- Turcite B on X and Y axis
- Double locks on all movable surfaces
- Hardened and ground square vertical knee ways and cross ways



STOCK NUMBER	690902 & 690912	690904 & 690914	690913 & 690915	690917 & 690919
Model Number	JTM-1050EVS/230CNC	JTM-1050EVS/460CNC	JTM-1050EVS/230CNC	JTM-1050EVS/460CNC
2-Axis CNC	690902	690904	690913	690917
3-Axis CNC	690912	690914	690915	690919
CNC Package	ACU-RITE MILLPWR®	ACU-RITE MILLPWR®	ANILAM 3000M	ANILAM 3000M
Table Size (in.)	10 x 50	10 x 50	10 x 50	10 x 50
Spindle Taper	R-8	R-8	R-8	R-8
Quill Diameter (in.)	3-3/8	3-3/8	3-3/8	3-3/8
Number of Spindle Speeds	Variable	Variable	Variable	Variable
Range of Spindle Speeds (RPM)	10 - 3,600	10 - 3,600	10 - 3,600	10 - 3,600
Quill Down Feed Rates (IPR)	.0015 - .003 - .006	.0015 - .003 - .006	.0015 - .003 - .006	.0015 - .003 - .006
Spindle Travel (in.)	5	5	5	5
Head Movement (deg.)	90° R & L, 45° F & B	90° R & L, 45° F & B	90° R & L, 45° F & B	90° R & L, 45° F & B
Max Distance Spindle to Table (in.)	19	19	19	19
Distance Spindle to Column (max./in.)	26	26	26	26
Distance Spindle to Column (min./in.)	5-1/2	5-1/2	5-1/2	5-1/2
Collet Capacity	1/8 - 7/8	1/8 - 7/8	1/8 - 7/8	1/8 - 7/8
Table Longitudinal Travel (in.)	30	30	30	30
Table Cross Travel (in.)	15-1/4	15-1/4	15-1/4	15-1/4
T-Slots Number and Size (in.)	3 and 5/8	3 and 5/8	3 and 5/8	3 and 5/8
T-Slot Centers (in.)	2-1/2	2-1/2	2-1/2	2-1/2
Work Table Weight Capacity (lbs.)	720	720	720	720
Travel of Knee (in.)	14-1/4	14-1/4	14-1/4	14-1/4
Travel of Ram (in.)	20-1/2	20-1/2	20-1/2	20-1/2
Motor	3HP, 230V Only, 3Ph	3HP, 460V Only, 3Ph	3HP, 230V Only, 3Ph	3HP, 460V Only, 3Ph
Overall Dimensions (in./ L x W x H)	96 x 71 x 88	96 x 71 x 88	96 x 71 x 88	96 x 71 x 88
Net Weight (lbs.)	3,000	3,000	3,000	3,000

# MILLING



# JTM-1055 MILL WITH ANILAM 3000M 3-AXIS CNC

## FEATURES

- Meehanite casting
- Hardened and ground table certified to be 52C Rockwell hardness
- Chrome leadscrews on X and Y axis
- Box style ways on Y and Z axis
- Satin chrome finished dials
- Precision bored and honed milling head
- Large diameter quill is chromed
- High precision Class 7 spindle bearings
- Chrome plated motor shaft has lower bearing support
- Motor pulleys are ground to increase belt lift
- One-piece quill pinion and shaft

## STANDARD EQUIPMENT

- One-shot lubrication system
- Way covers
- Draw bar
- Tool box with tools



STOCK NUMBER	690925
Model Number	JTM-1055
Table Size (in.)	10 x 54
Spindle Taper	NST #40
Quill Diameter (in.)	4-1/8
Number of Spindle Speeds	Variable
Range of Spindle Speeds (RPM)	80 - 3,800
Quill Down Feed Rates (IPR)	.0015 - .003 - .006
Spindle Travel (in.)	5
Head Movement (deg.)	90° R & L
Max Distance Spindle to Table (in.)	20
Distance Spindle to Column (max./in.)	26
Distance Spindle to Column (min./in.)	5-1/2
Collet Capacity	1/8 - 7/8
Table Longitudinal Travel (in.)	32
Table Cross Travel (in.)	16
T-Slots Number and Size (in.)	3 and 5/8
T-Slot Centers (in.)	2-1/2
Work Table Weight Capacity (lbs.)	800
Travel of Knee (in.)	17-1/2
Travel of Ram (in.)	20-1/2
Motor	5HP, 230/460V, 3Ph, Prewired 230V
Overall Dimensions (in./ L x W x H)	92 x 80 x 108
Net Weight (lbs.)	3,400



ANILAM 3000M Control

**JET**



# DIGITAL READOUTS FOR MILLING APPLICATIONS

The days of inaccurate measurement conversions due to math errors and productivity lulls caused by lost data are over. JET offers a variety of Digital Readout packages for JET Turning Machines designed to keep track of position, provide prompt feedback and messaging, and quick configuration of machine features. Die-cast metal construction ensures unit reliability and displays are very easy to read. Add the right Digital Readout unit to the JET Mill in your shop.



## ANILAM DIGITAL READOUTS

The ANILAM Wizard 411 is a simple cost effective entry level solution for manual machine tool applications. The Wizard 411 features exclusive LCD display screen technology and versatile software to accommodate milling, turning or grinding applications. The ANILAM Wizard 411 is the first readout in the industry to display full text on a crystal clear LCD display. Plus, a content-sensitive help function assists you right on screen.

### WIZARD 411 FEATURES/TECHNICAL DATA

- 1, 2 or 3-axes 5.7" transmissive LCD display
- Job Clock
- Feed rate display
- Multiple language supports
- Zero reset capability
- Instant radius/diameter conversion
- Absolute/incremental display
- Instant inch/mm conversion
- Conversational message prompts
- Linear error compensation
- Die-cast enclosure
- Precision Glass Scales

### SPECIFIC FEATURES

- Bolthole pattern calculations with graphics (full and partial circles/linear patterns)
- Centerline calculation enables you to establish workpiece zero and midpoints

### Precision Glass Scales

With more than one million scales in use today, ANILAM precision glass scales withstand the elements of contamination found in even the harshest machine shop environments. As a result, our precision glass scales resist changes in size, shape or density due to temperature and humidity variations. This stability provides exceptional accuracy down to  $\pm 1.5\mu\text{m}$  (.00006"), resulting in tighter workpiece tolerances.

# ANILAM<sup>®</sup>



# MILLING



# ACU-RITE DRO SERIES FOR MILLING APPLICATIONS

## ACU-RITE DROS COMMON FEATURES

- Job Clock
- Feed Rate Display
- Multiple Language Support
- Absolute/Incremental
- Near-Zero Warning
- Help Function
- 16 Tool Offsets/Diameter
- Preset and zero reset
- 4 Function Calculator/Trig Calculator
- Instant Inch/mm conversion
- Bolthole pattern calculations with graphics (full and partial circles/linear patterns)
- Centerline calculation enables you to establish workpiece zero and midpoints

## VUE

The Acu-Rite VUE is a cost-effective, entry-level solution for manual machine tool applications. With our innovative LCD display screen technology and versatile software to accommodate milling, turning or grinding applications the VUE is everything you need at a price you can afford.

### VUE SPECIFIC FEATURES

- 1, 2 or 3 axes 5.7" Transmissive LCD display
- 200mm Fixed Reference Marks

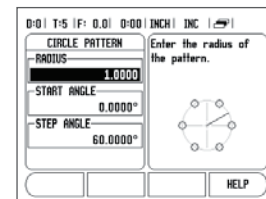

## 200S

As the industry standard in digital readout systems, the Acu-Rite 200S offers state-of-the-art features for milling, turning and grinding applications.

### 200S SPECIFIC FEATURES

- 2 or 3 axes 5.7" Transmissive LCD display
- Position-Trac™ Home Reference

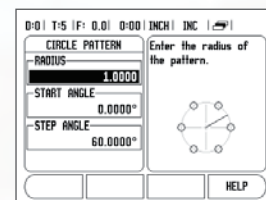

## 300S

The Acu-Rite 300S is a fully programmable 4 axes readout system, now available with a full color display. With the capability to store and create a library of programs the 300S is everything you need to create, edit and execute programs on your

### 300S SPECIFIC FEATURES

- 2, 3 or 4 axes 5.7" Full Color Display
- Multiple program names with numerous steps
- Multiple display views
- Position-Trac™ Home Reference
- Edge finder/touch probe input

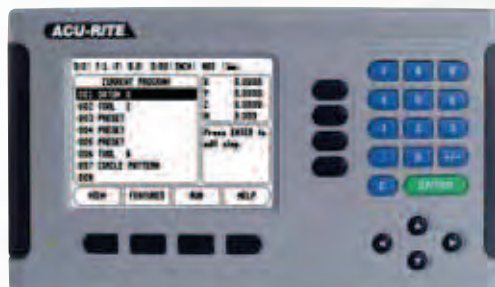



# NEWALL DIGITAL READOUTS FOR MILLING APPLICATIONS

## DP700

The DP700 is the latest in Newall's line of a powerful and intuitive DROs. The unit is housed in a rugged, ergonomically designed casing. The DRO features all of the essential functions for milling, boring, turning, grinding, and general machining operations. The DP700 is compatible with Newall's Spherosyn and Microsyn encoders which withstand the harshest shop conditions.

### STANDARD FEATURES

- Feed Rate Display
- Bolt Hole Circle Routine
- Line Hole Routine
- Arc Contouring
- Programmable Memory/Teach
- Polar Coordinates
- Line Hole Calculator
- Tool Offsets
- Taper Calculations
- Axis Vectoring/Summing
- Linear and Segmented Error Comp.
- Undo
- RS232 Output
- Languages: English, French, German, Spanish, Italian, Turkish, Czech, Russian, Portuguese, Danish

### SPECIFIC FEATURES

- Clean, Crisp, Easy to Read, LEDs
- Intuitive Message Window
- Long Life Membrane Keypad
- Solid cast construction
- Safe, Low Voltage Power Supply (UL)
- Panel Mount Version Available

# NEWALL



## DP900

Setting new performance standards, the DP900 integrates the latest innovations in electronic design, housed in a rugged die-cast chassis. The feather-touch keypad ensures long life and stability throughout the rugged shop environment. The DRO offers flexible features tailored for milling or turning applications. Plus, with the use of a touch probe, part inspection calculations can be performed without removing the part from the machine.

### STANDARD FEATURES

- Rugged Die-Cast Chassis
- Feather-Touch, Cap-Sense Keypad
- 5.7" QVGA Blue STN with CCFL Backlight
- 2, 3, or 4 Axes with Optional Rotary Axis
- Graphical Tool Path Verification
- Customized Canned Cycles
- Remote Storage via USB Port
- CMM/Inspection Functions with Probe Capabilities
- Feed Rate Display
- Polar Coordinate Readings
- Touch Probe Input
- Teach Mode with Graphics
- Intuitive Help Menus

### SPECIFIC FEATURES

- Bolt Hole Circle Routine (full and partial)
- Line Hole
- Frame (Pocketing)
- Grid Array
- Arc Function
- Tool Length Compensation
- Tool Diameter Compensation
- Tap Drill Library

### Increase Productivity with Tool Path Verification

The DP900 includes a graphical display of your tool path movement. This time-saving feature enables the operator to graphically view the tool movement in real time, increasing productivity.



# MILLING



## TABLE AND KNEE POWERFEEDS

- Specially designed for each model
- X-, Y-, and Z-axis available
- Provides continuously variable feed rate of up to 37 in./min.
- Adjustable stops allow automatic shut off
- Includes rapid traverse button
- Built-in clutch helps prevent damage in overload
- Factory installation available
- Installation of powerfeed will reduce table travel



STOCK NUMBER	350087	350089	350094	350095	350097
Model Number	TPFA-2Y	TPFA-2X	TPFA-2XN	TPFA-2YN	TPFA-2Z
Speed Rate/Variable (IPM)	0-37	0-37	0-37	0-37	0-37
Torque (in./lbs.)	135	135	150	150	150
Rapid Traverse (IPM)	37	37	37	37	37
Motor	2-1/2AMP, 115V, 1Ph	2-1/2AMP, 115V, 1Ph	2-1/2AMP, 115V, 1Ph	2-1/2AMP, 115V, 1Ph	2-1/2AMP, 115V, 1Ph
Net Weight (lbs.)	14	14	14	14	14
To Fit Mill:	Stock Number Y-axis	Stock Number X-axis	Stock Number X-axis	Stock Number Y-axis	Stock Number Z-axis
JVM-836	350087	350089	350094	350095	350097
JTM-1&2	350087	350089	350094	350095	350097
JTM-4VS	350087	350089	350094	350095	350097
JTM-1050	350086K	350089	350094	350098K	350097
JTM-1050EVS	350086K	350089	350094	350098K	350097
JTM-1055	350086K	350089	350094	350098K	350097

## SWING AWAY ADJUSTABLE SAFETY SHIELD

These shields are intended to deflect chips, sparks, coolant or lubricant away from the operator and other employees in the machine area. They offer excellent visibility to the point of operation to help increase worker safety. The adjustable shields easily swing in or out of position.

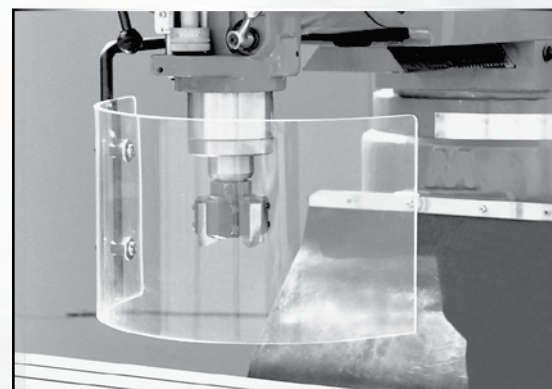

STOCK NUMBER	DESCRIPTION
A635	Safety Shield





## MIST OR FLOOD COOLANT SYSTEM FOR MILLING MACHINES

Air and coolant line connections are encased in braided metal wire. One gallon tank is made of enamel paint finished metal with removable corrosion resistant inner liner.

STOCK NUMBER	DESCRIPTION
A619	Flood Coolant System for Models 220V/440V, 3Ph



## RISER BLOCKS

- Specially designed for each model
- Adds 6" – 8" height capacity
- Includes all mounting hardware

STOCK NUMBER	MILL MODEL	SIZE (IN.)
Not Available	JVM-836	-
350090	JTM-1&2	6
350090	JTM-4VS	6
350096	JTM-1050	8
350096	JTM-1050EVS	8
Not Available	JTM-1055	-



## AIR POWER DRAW BAR

- Fits all JET variable speed milling machines and JTM-1/2 step pulley mills
- High quality industrial grade air motor
- Double impact high torque design
- Easy installation requires no drilling or tapping
- Air requirements: 3 CFM at 90 PSI

STOCK NUMBER	MILL MODEL
Not Available	JVM-836
A630	JTM-1&2
A630	JTM-4VS
A630	JTM-1050
A630	JTM-1050EVS
A631	JTM-1055





# MILLING ACCESSORIES

**90**  
DAY  
WARRANTY

## MILLING CHUCK AND COLLET SETS

- 17 pc. set in a wooden case
- Can quickly change from one shank size to another without loosening the draw bar
- 15 precision spring collets take the place of 15 individual adaptors
- Can be used for milling, drilling, reaming and boring operations
- Complete with spanner wrenches
- Collets are in increments of 1/16"
- T.I.R. at 2-3/8" is 0.0008"



STOCK NUMBER	466001
Model Number	CCS-1
Shank Taper	R-8
Capacity (in.)	1/8- 1

## HORIZONTAL / VERTICAL ROTARY TABLES

- 6" to 10" tables are made of high density Meehanite
- Hardened and ground worm gear
- Widely used circular cutting, angle setting, boring and spot facing in the horizontal position

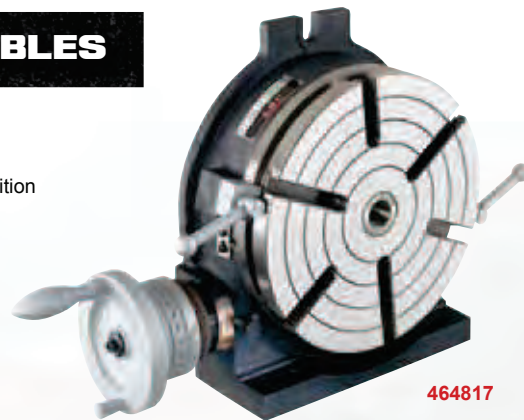

STOCK NUMBER	464815	464816	464817
Table Size (in.)	6	8	10
Center Sleeve	MT-2	MT-3	MT-3
T-Slot Size (in.)	3/8	1/2	1/2
Net Weight (lbs.)	23	62	95

## R8 COLLET SETS AND RACKS

- Precision hardened and ground
- R8 Collets for use on milling machines
- Premium collets with 0.0005mm T.I.R.

STOCK NUMBER	DESCRIPTION
650132	CS-R8, 6 pc. R-8 Collet Set 1/8" - 3/4" by 1/8ths for Mills
650135	19 pc. Premium R-8 Collet Set 2mm - 20mm by 1mm with Rack
650136	Metal Collet Rack holds 12 R8 Collets
650137	Metal Collet Rack holds 48 R8 Collets
650138	Wooden Collet Rack holds 14 R8 Collets



**JET**





## MILLING TOOL KITS

### 660100KT Includes:

- 650132 Collet Set CS-R8, 6 pc. R-8 Collet Set 1/8" - 3/4" by 1/8ths for Mills
- 660012 Clamping Kit includes metal storage tray can be mounted on machine or wall, Three complete sets to choose from 52 pc. kit includes: Six T-slot nuts
- 660220 Tooling Kit 24 pc. Milling Tool Kit for R8-Spindle Milling Machines and 63186 Verti-lock Machine Vise

STOCK NUMBER	DESCRIPTION
660220	24 pc. Milling Tool Kit for R8-Spindle Milling Machines
660100KT	Milling Accessory Kit



## CLAMPING KITS

- Metal storage tray can be mounted on machine or wall
- Three complete sets to choose from
- 52 pc. kit includes: Six T-slot nuts, Six Flange nuts, Four Coupling nuts, Six Step blocks, Six Step clamps, Twenty four Studs, four each (3", 4", 5", 6", 7" & 8" lengths)

STOCK NUMBER	660038	660012	660058
Model Number	CK-38	CK-12	CK-58
Stud Size	3/8" - 16 T.P.I.	1/2" - 13 T.P.I.	5/8" - 11 T.P.I.
T-Slot Sizes (in.)	7/16 and 1/2	9/16 and 5/8	11/16 and 3/4



## I-2-3 BLOCK SET

- Squareness: 0.0001"
- Parallelism: 0.0001"
- Height accuracy in pairs +/- 0.0001"
- Hardness HRC 56-60
- 5 pc. 3/8" - 16 socket head cap screws
- 1 pc. Hex Key
- Plastic Case

STOCK NUMBER	DESCRIPTION
630400	1-2-3 Block Set in Plastic Case





# MILLING PACKAGES :: STEP PULLEY

STOCK NUMBER	690036	690038	690082	690089
Type	STEP PULLEY	STEP PULLEY	STEP PULLEY	STEP PULLEY
Model Number	JVM-836-1	JVM-836-3	JTM-1	JTM-2
Table Size (in.)	9 x 36	8 x 36	9 x 42	9 x 42
Spindle Taper	R8	R8	R8	R8
<b>MILL INCLUDED IN ALL PACKAGE NUMBERS LISTED BELOW</b>				
X Axis Powerfeed	690156	690174	690019	690006
X & Y Axis Powerfeeds	690211	690175	690097	690017
Anilam 411 2-Axis DRO	690239	690191	690280	690283
Anilam 411 2-Axis DRO & X-Axis Powerfeed	690198	690194	690281	690286
Anilam 411 2-Axis DRO & X & Y-Axis Powerfeeds	690212		690282	690285
Anilam 411 3-Axis DRO (Quill) & X-Axis Powerfeed	690213			
Anilam 411 3-Axis DRO (Knee) & X & Y & Z-Axis Powerfeeds			690145	
Acu-Rite 200S 2-Axis DRO	690177	690190	690244	
Acu-Rite 200S 2-Axis DRO & X-Axis Powerfeed	690144	690146	690168	690114
Acu-Rite 200S 2-Axis DRO & X & Y Axis Powerfeed	690162		690161	690210
Acu-Rite 200S 3-Axis DRO & X-Axis Powerfeed (Quill)				690072
Acu-Rite 200S 3-Axis DRO & X & Y-Axis Powerfeed (Quill)				690157
Acu-Rite 200S 3-Axis DRO (Knee)				690088
Newall DP700 2-Axis DRO	691173	691179	691187	691193
Newall DP700 2-Axis DRO & X-Axis Powerfeed	691174	691180	691188	691194
Newall DP700 2-Axis DRO & X & Y Axis Powerfeeds	691175	691183	691189	691195
Newall DP700 3-Axis DRO (Quill)	691176	691184	691190	691197
Newall DP700 3-Axis DRO & X-Axis Powerfeed (Quill)	691177	691185	691191	691198
Newall DP700 3-Axis DRO & X & Y-Axis Powerfeeds (Quill)	691178	691186	691192	691199
Newall DP700 3-Axis DRO (Knee)	691228		691196	

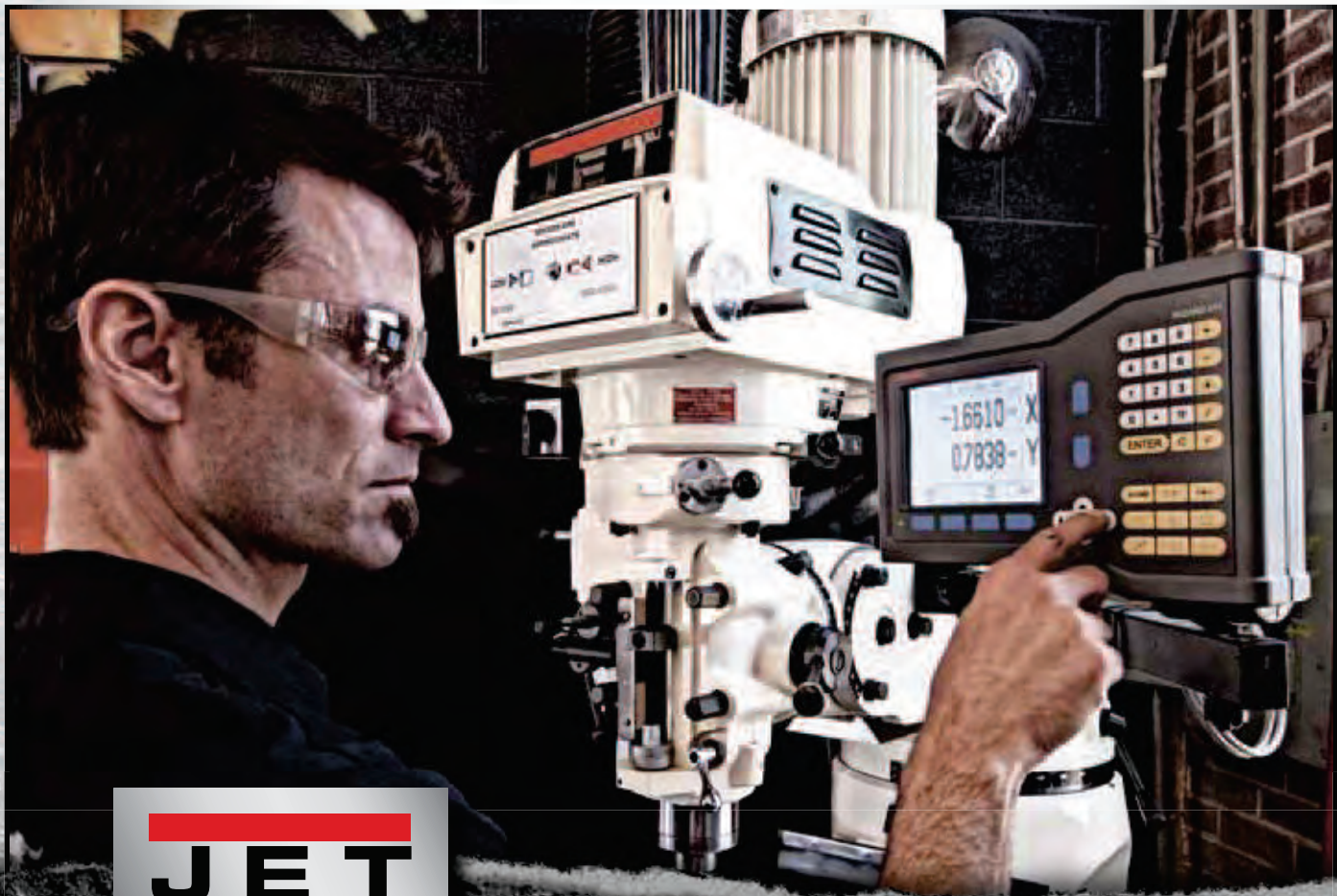

**JET**



# MILLING PACKAGES :: VARIABLE SPEED

STOCK NUMBER	690182	690180	690050	690060	690062	690053	690055
Type	VARIABLE SPEED	VARIABLE SPEED	VARIABLE SPEED	VARIABLE SPEED	VARIABLE SPEED	VARIABLE SPEED	VARIABLE SPEED
Model Number	JTM-4VS	JTM-4VS-1	JTM-1050	JTM-1050EVS/230	JTM-1050EVS/460	JTM-1054R	JTM-1055
Table Size (in.)	9 x 49	9 x 49	10 x 50	10 x 50	10 x 50	10 x 54	10 x 54
Spindle Taper	R8	R8	R8	R8	R8	R8	NT40
<b>MILL INCLUDED IN ALL PACKAGE NUMBERS LISTED BELOW</b>							
X Axis Powerfeed	690183	690178	690120	690011	690189		
Air Draw Bar	690119						
X Axis Powerfeed & Air Draw Bar						690274	690255
X & Y Axis Powerfeeds	690008		690150	690315	690319		690218
X, Y & Z Axis Powerfeeds	690013						
X & Y Axis Powerfeeds & Air Draw Bar	690009						690260
Anilam 411 2-Axis DRO & X-Axis Powerfeed	690401	690402	690403	690404	690405	690270	690275
Anilam 411 2-Axis DRO & X-Axis Powerfeed & Air Draw Bar						690052	
Anilam 411 2-Axis DRO & X & Y-Axis Powerfeeds	690420	690407	690409			690272	
Anilam 411 2-Axis DRO & X & Z-Axis Powerfeeds				690414			
Anilam 411 3-Axis DRO (Quill) & X-Axis Powerfeed		690410					
Anilam 411 3-Axis DRO (Quill) & X & Y-Axis Powerfeeds		690413					
Anilam 411 3-Axis DRO (Knee) & X-Axis Powerfeed	690408	690411					
Anilam 411 3-Axis DRO (Knee) & X & Y-Axis Powerfeeds	690416	690412					
Acu-Rite 200S 2-Axis DRO	690202						690250
Acu-Rite 200S 2-Axis DRO & X-Axis Powerfeed		690179	690117	690127	690137	690271	690220
Acu-Rite 200S 2-Axis DRO & X-Axis Powerfeed & Air Draw Bar	690125			690257			
Acu-Rite 200S 2-Axis DRO & X & Y Axis Powerfeed	690098		690214	690406	690154		690222
Acu-Rite 200S 2-Axis DRO & X & Y-Axis Powerfeed & Air Draw Bar	690230						
Acu-Rite 200S 2-Axis DRO & X & Y & Z-Axis Powerfeed							690229
Acu-Rite 200S 3-Axis DRO (Quill)	690184						
Acu-Rite 200S 3-Axis DRO & X-Axis Powerfeed (Quill)	690221		690158				
Acu-Rite 200S 3-Axis DRO & X-Axis Powerfeed & Air Draw Bar (Quill)	690251						
Acu-Rite 200S 3-Axis DRO & X & Y-Axis Powerfeed (Quill)	690140	690068	690159				
Acu-Rite 200S 3-Axis DRO & X & Y & Z Powerfeed (Quill)	690141		690160				
Acu-Rite 200S 3-Axis DRO & X & Y Powerfeed & Air Draw Bar (Quill)			690151				
Acu-Rite 200S 3-Axis DRO & X & Y & Z Powerfeed & Air Draw Bar (Quill)	690153						
Acu-Rite 200S 3-Axis DRO (Knee)				690056			
Acu-Rite 200S 3-Axis DRO & X-Axis Powerfeed (Knee)					690138		
Acu-Rite 200S 3-Axis DRO & X & Y-Axis Powerfeed (Knee)				690155			
Acu-Rite 200S 3-Axis DRO & X & Y-Axis Powerfeed & Air Draw Bar (Knee)				690124			
Acu-Rite 300S 2-Axis DRO & X-Axis Powerfeed	690301	690303	690306	690311	690316	690322	690320
Acu-Rite 300S 2-Axis DRO & X-Axis Powerfeed & Air Draw Bar				690300			
Acu-Rite 300S 2-Axis DRO & X & Y Axis Powerfeed	690302		690307	690312	690313		690321
Acu-Rite 300S 3-Axis DRO & X & Y-Axis Powerfeed (Knee)				690310			
Acu-Rite 300S 3-Axis DRO & X & Y-Axis Powerfeed (Quill)		690118					
Newall DP700 2-Axis DRO	691200		691204	691210	691216		691222
Newall DP700 2-Axis DRO & Air Draw Bar			691172				
Newall DP700 2-Axis DRO & X-Axis Powerfeed	690087		691205	691211	691217		691223
Newall DP700 2-Axis DRO & X & Y-Axis Powerfeeds	691201		691206	691212	691218		691224
Newall DP700 2-Axis DRO & X & Y-Axis Powerfeeds & Air Draw Bar					691231		
Newall DP700 2-Axis DRO & X & Y & Z-Axis Powerfeeds							691223
Newall DP700 3-Axis DRO (Quill)	691202		691207	691213	691219		691225
Newall DP700 3-Axis DRO & X-Axis Powerfeed (Quill)	690090		691208	691214	691220		691226
Newall DP700 3-Axis DRO & X & Y-Axis Powerfeeds (Quill)	691203		691209	691215	691221		691227
Newall DP700 3-Axis DRO & X-Axis Powerfeed (Knee)	691232						
Newall DP700 3-Axis DRO & X & Y & Z Axis Powerfeed (Knee)	690093						
Newall DP900 2-Axis DRO & X-Axis Powerfeed	690301		690308	690314	690318		
Newall DP900 2-Axis DRO & X & Y-Axis Powerfeeds	690305		690309				
Newall DP900 2-Axis DRO & X & Z-Axis Powerfeeds			690299				







  
**J E T**<sup>®</sup>





# DRILLING

The complete line of JET Drilling machines ensure exact spacing and precision depth control with every press. Designed to last and provide the user with enhanced flexibility, the right JET Drill Press is available for both a commercial or maintenance shop. The industry's leading warranty and professional manuals for efficient operation assures every user of JET machines that we stand behind our products.

**PRECISION  
DEPTH  
CONTROL  
WITH EVERY  
PRESS**



# 15" AND 20" DRILL PRESSES



## FEATURES

- Cast iron head
- Large quill allows greater accuracy
- Head casting features a permanently lubricated ball bearing spindle assembly, using four heavy duty ball bearings mounted in an enclosed quill for extended life
- Massive T-slotted production work table (Model 2550 only)
- Table tilts 45°
- Large ground steel column diameter for maximum head and table support
- 3-1/8" stroke for deep hole applications (4-3/4" on model 2550)
- Accurate depth stop for precise hole depths

## STANDARD EQUIPMENT

- 5/8" Drill chuck and arbor

STOCK NUMBER	354401	354400	354402
Model Number	J-2530	J-2500	J-2550
Drilling Capacity Cast Iron (in.)	5/8	5/8	3/4
Drilling Capacity Mild Steel (in.)	1/2	1/2	5/8
Column Diameter (in.)	2-7/8	2-7/8	3-5/8
Distance Column to Spindle (in.)	7-1/2	7-1/2	10-1/2
Range of Spindle Speeds (RPM)	200, 290, 350, 430, 500, 580, 640, 720, 800, 870, 1440, 1630, 1820, 2380, 2540, 3630	200, 290, 350, 430, 500, 580, 640, 720, 800, 870, 1440, 1630, 1820, 2380, 2540, 3630	150, 260, 300, 440, 490, 540, 1150, 1550, 1840, 2220, 2950, 4200
Spindle Travel (in.)	3-1/8	3-1/8	4-3/4
Spindle Distance to Base (in.)	24	48	43-1/2
Spindle Distance to Table (max./in.)	15-1/2	24	24
Table Size (in.)	11-1/2 x 11-1/2	11-1/2 x 11-1/2	18-1/2 x 16-1/2
Table Travel (in.)	15-1/2	24	21-1/2
T-Slots Number and Size (in.)	N/A	N/A	3 x 1/2
T-Slot Centers (in.)	N/A	N/A	4
Work Table Weight Capacity (lbs.)	44	44	66
Spindle Taper	MT-2	MT-2	MT-3
Base Dimensions (LxW/ in.)	18 x 10-1/2	11 x 19-1/2	22-3/4 x 17-3/4
Base Work Table (in.)	8 x 8	7x 7-1/2	13 x 14-1/2
Motor	3/4HP, 1Ph, 115V	3/4HP, 115V, 1Ph,	1 HP, 1Ph, 115/230V, Prewired 115V
Overall Dimensions (in./ LxWxH)	31 x 13 x 39-1/2	31 x 13 x 63	33-1/2 x 18-1/2 x 67
Net Weight (lbs.)	157	167	304



354401



354400



354402





# 15" 6-SPEED DRILL PRESSES

**2**  
**YEAR** WARRANTY

## FEATURES

- Constructed to provide a solid base for drilling
- Offers a greater range in spindle speeds than others in this class
- Larger quill provides greater accuracy
- Large production work table gives the operator the room to work and support for the job
- 3" Column for head support, while the quill is also supported to lessen deflection

## STANDARD EQUIPMENT

- 1/2" Drill chuck and arbor



STOCK NUMBER	354500
Model Number	J-A3816
Drilling Capacity Cast Iron (in.)	5/8
Drilling Capacity Mild Steel (in.)	1/2
Column Diameter (in.)	3
Distance Column to Spindle (in.)	15
Range of Spindle Speeds (RPM)	375, 625, 1125, 1950, 3400, 5000
Spindle Travel (in.)	6
Spindle Distance to Base (in.)	44-1/2
Max Distance Spindle to Table (in.)	25-3/4
Table Size (in.)	15 x 18
Table Travel (in.)	16-3/4
T-Slots Number and Size (in.)	2 & 1/2
T-Slot Centers (in.)	5-5/16
Work Table Weight Capacity (lbs.)	90
Spindle Taper	MT-2
Base Dimensions (LxWxH/ in.)	20-7/8 x 14-3/16 x 3-1/8
Base Work Table (in.)	12-1/8 x 1-13/16
Base Slots Number & Size (in.)	2 & 1/2
Motor	1HP, 115/230VAC, 1Ph, Prewired 115V
Overall Dimensions (in./ LxWxH)	30 x 20 x 71
Net Weight (lbs.)	394



# 20" FLOOR DRILL PRESS

**2**  
**YEAR** WARRANTY

## FEATURES

- Hinged metal belt and pulley cover coupled with quick adjustment motor mount allow rapid changing of spindle speeds
- Rotating, 45° tilting, crank-operated worktable with quick release clamp
- On/off switch located on front of the drill press head
- A 1/2" diameter external positive depth stop with three nut locking feature for quick adjustment
- Adjustable tension spindle return spring
- Spindle is supported by high quality ball bearings
- Built-in work lamp on all models, bulb not included.
- Drill chuck and key included



STOCK NUMBER	354170
Model Number	JDP-20MF
Drilling Capacity Cast Iron (in.)	1
Drilling Capacity Mild Steel (in.)	3/4
Column Diameter (in.)	3-3/8
Distance Column to Spindle (in.)	10
Range of Spindle Speeds (RPM)	150-4200
Spindle Travel (in.)	4-5/8
Spindle Distance to Base (in.)	46-3/4
Max Distance Spindle to Table (in.)	29-1/8
Table Size (in.)	18-1/2 x 16
T-Slots Number and Size (in.)	6 & 1/2
T-Slot Centers (in.)	3-1/2
Work Table Weight Capacity (lbs.)	80
Spindle Taper	MT-3
Base Dimensions (in./ LxWxH)	13-3/4 x 22-3/4
Base Work Table (in.)	13 x 8-1/2
Base Slots Number & Size (in.)	2 & 5/8
Motor	1-1/2HP, 1Ph, 115/230V, Prewired 115V
Overall Dimensions (in./LxWxH)	31-1/2 x 18-1/2 x 66
Net Weight (lbs.)	282



**Large Cast Iron Head with Easy to use Spider Handle**



**1/2" Diameter External Positive Depth Stop**

**JET**

086



# 15" VARIABLE SPEED DRILL PRESSES



## FEATURES

- Speeds from 400 to 5000 RPM
- Handwheel adjustment sets the speeds
- Large 2-1/4" quill allows greater accuracy
- 3" Column diameter for maximum head support
- Full bearing support on quill for maximum spindle stiffness
- 6" stroke for deep hole application
- Accurate depth stop for precise hole depths
- 1/2" drill chuck & arbor
- Safety collar



STOCK NUMBER	354550	354551
Model Number	J-A5816	J-A5818
Drilling Capacity Cast Iron (in.)	5/8	5/8
Drilling Capacity Mild Steel (in.)	1/2	1/2
Column Diameter (in.)	3	3
Distance Column to Spindle (in.)	7-1/2	7-1/2
Spindle Travel (in.)	6	6
Spindle Distance to Base (in.)	44-1/2	44-1/2
Max Distance Spindle to Table (in.)	25-3/4	25-3/4
Table Size (in.)	15 x 18	15 x 18
Table Travel (in.)	16-3/4	16-3/4
T-Slots Number and Size (in.)	2 & 1/2	2 & 1/2
T-Slot Centers (in.)	5-5/16	5-5/16
Work Table Weight Capacity (lbs.)	90	90
Spindle Taper	MT-2	MT-2
Range of Spindle Speeds (RPM)	400 - 5000	400 to 5000
Base Dimensions (in./ LxWxH)	20-7/16 x 14-3/16 x 3-1/8	20-7/16 x 14-3/16 x 3-1/8
Base Work Table (in.)	12-1/8 x 11-13/16	12-1/8 x 11-13/16
Base Slots Number & Size (in.)	2 & 1/2	2 & 1/2
Motor	1HP, 1 Ph, 115/230V, Prewired 115V	1HP, 3 Ph, 230/460V, Prewired 230V
Overall Dimensions (in./ LxWxH)	30 x 20 x 71	30 x 20 x 71
Net Weight (lbs.)	426	426



# 20" VARIABLE SPEED DRILL PRESSES



## FEATURES

- Variable spindle speeds from 300 to 2000 RPM
- #3 Morse Taper
- Front mounted positive control depth stop
- 6" Quill travel
- Massive 3" quill diameter
- Heavy duty cast iron design
- Large precision ground T-Slot production table for easy set ups
- Front or side rack and worm gear table raiser
- Table rotates 360° around the column
- Machined T-Slotted base
- Head is massively constructed for more accuracy and rigidity

STOCK NUMBER	354221	354223
Model Number	J-2221VS	J-2223VS
Drilling Capacity Cast Iron (in.)	1-1/4	1-1/4
Drilling Capacity Mild Steel (in.)	1	1
Column Diameter (in.)	4-1/2	4-1/2
Distance Column to Spindle (in.)	10-7/16	10-7/16
Range of Spindle Speeds (RPM)	300 to 2000	300 to 2000
Spindle Travel (in.)	6	6
Spindle Distance to Base (in.)	43-5/16	43-5/16
Max Distance Spindle to Table (in.)	30-1/4	30-1/4
Table Size (in.)	18-1/8 x 14-3/4	18-1/8 x 14-3/4
Table Travel (in.)	18	18
T-Slots Number and Size (in.)	2 & 5/8	2 & 5/8
T-Slot Centers (in.)	7-7/16	7-7/16
Work Table Weight Capacity (lbs.)	176	176
Spindle Taper	MT-3	MT-3
Base Dimensions (in./ LxWxH)	27-1/2 x 19-1/4 x 6-1/8	27-1/2 x 19-1/4 x 6-1/8
Base Work Table (in.)	14-3/4 x 11-13/16	14-3/4 x 11-13/16
Base Slots Number & Size (in.)	2 & 5/8	2 & 5/8
Motor	2HP, 1Ph, 115/230V, Prewired 115V	2HP, 3Ph, 230/460V Prewired 230V
Overall Dimensions (in./ LxWxH)	37 x 27 x 77	37 x 27 x 77
Net Weight (lbs.)	715	715



354221



Drill Chuck and Key

STOCK NUMBER	DESCRIPTION
5512104	Coolant system, 1/8HP pump, 115/220V, 1Ph
5508071	Coolant system, 1/8HP pump, 220/440V, 3Ph





# ELECTRONIC VARIABLE SPEED DRILL PRESSES



## FEATURES

- Variable spindle speed from 65 to 2000RPM
- MT-3 spindle taper
- Latest AC inverter variable speed technology
- High torque at all speeds both forward and reverse
- Continuous speed adjustment while in operation
- Front mounted LED spindle RPM readout
- Forward and reverse for tapping
- Emergency stop
- Front mounted positive control depth stop
- Large precision ground T-slot production table for easy set ups
- Heavy duty casted head for more accuracy and rigidity

STOCK NUMBER	354214	354216
Model Number	J-2232AC	J-2234AC
Drilling Capacity Cast Iron (in.)	1-1/2	1-1/2
Drilling Capacity Mild Steel (in.)	1-3/8	1-3/8
Column Diameter (in.)	4-1/2	4-1/2
Distance Column to Spindle (in.)	10-7/16	10-7/16
Range of Spindle Speeds (RPM)	65 - 2000	65 - 2000
Spindle Travel (in.)	6	6
Spindle Distance to Base (in.)	43-5/16	43-5/16
Max Distance Spindle to Table (in.)	30-1/4	30-1/4
Table Size (in.)	18-1/8 x 14-3/4	18-1/8 x 14-3/4
Table Travel (in.)	18	18
T-Slots Number and Size (in.)	2 & 5/8	2 & 5/8
T-Slot Centers (in.)	7-7/16	7-7/16
Work Table Weight Capacity (lbs.)	176	176
Spindle Taper	MT-3	MT-3
Base Dimensions (in./ LxWxH)	27-1/2 x 19-1/4 x 6-1/8	27-1/2 x 19-1/4 x 6-1/8
Base Work Table (in.)	14-3/4 x 11-13/16	14-3/4 x 11-13/16
Base Slots Number & Size (in.)	2 & 5/8	2 & 5/8
Motor	2HP, 220V, 3Ph*	2HP, 460V, 3Ph
Overall Dimensions (in./ LxWxH)	37 x 27 x 80	37 x 27 x 80
Net Weight (lbs.)	792	792

\*J-2232AC can also run as 220V, Single Phase



354214



Table Rotates 360 Degrees Around the Column



# 20" ELECTRONIC VARIABLE SPEED DRILL PRESSES



## FEATURES

- Runs quieter and smoother than a conventional variable speed head
- 230V model can run on single phase power
- Low maintenance head has less moving parts
- Incorporates a high-low gear box to maintain low speed torque
- Chrome molybdenum gears are hardened, ground, and shaved
- Quiet running and longer life
- Speed can be adjusted in each range during operation
- LED spindle RPM readout is conveniently mounted
- Tapping mode allows instantaneous spindle reversal
- Easy to read internal depth gauge
- Extra large emergency stop button adds to safe operation
- Table can be raised from the front or side
- Large production table and T-slotted dish-in base

## STANDARD EQUIPMENT

- Integrated tapping and reversing controls
- Complete coolant system
- T-slotted work table



STOCK NUMBER	354210	354212
Model Number	JDP-20EVS/230	JDP-20EVS/460
Drilling Capacity Cast Iron (in.)	1-1/2	1-1/2
Drilling Capacity Mild Steel (in.)	1-3/8	1-3/8
Column Diameter (in.)	4-1/2	4-1/2
Distance Column to Spindle (in.)	10-7/16	10-7/16
Range of Spindle Speeds (RPM)	65 - 2000	65 - 2000
Spindle Travel (in.)	6	6
Spindle Distance to Base (in.)	43-5/16	43-5/16
Max Distance Spindle to Table (in.)	30-1/4	30-1/4
Table Size (in.)	18-1/8 x 14-3/4	18-1/8 x 14-3/4
Table Travel (in.)	18	18
T-Slots Number and Size (in.)	2 & 5/8	2 & 5/8
T-Slot Centers (in.)	7-7/16	7-7/16
Spindle Taper	MT-3	MT-3
Base Dimensions (in./ LxWxH)	27-1/2 x 19-1/4 x 6-1/8	27-1/2 x 19-1/4 x 6-1/8
Base Work Table (in.)	14-3/4 x 11-13/16	14-3/4 x 11-13/16
Base Slots Number & Size (in.)	2 & 5/8	2 & 5/8
Motor	2HP, 3PH, 230V only	2HP, 3PH, 460V only
Overall Dimensions (in./ LxWxH)	37 x 37 x 83	37 x 37 x 83
Net Weight (lbs.)	722	722



# GEARED HEAD DRILL PRESSES

When you need a heavy-duty machine capable of production drilling and quick set-up changes you need JET Geared Head Drill Presses. Designed to perform a variety of precision drilling applications, JET Geared Head Drill Presses have calibrated fine down feed built in, easy-to-read depth gauges and the lack of friction elements results in less down time. The JET Geared Head Drill Press is perfect for the tool room or commercial shop with high production demand.



## 20" GEARED HEAD DRILL PRESSES

### FEATURES

- Heavy duty design allows a variety of precision drilling applications
- Easy to read internal depth gauge
- Calibrated fine down feed built-in
- Built-in spindle lock
- Head tilts left or right
- Easy accessible table raiser
- Large production table and T-slotted base

### STANDARD EQUIPMENT

- T-slotted worktable
- Drill chuck arbor
- Draw bar

STOCK NUMBER	354020	354024
Model Number	GHD-20	GHD-20PF
Drilling Capacity Cast Iron (in.)	1-1/2	1-1/2
Drilling Capacity Mild Steel (in.)	1-1/4	1-1/4
Column Diameter (in.)	4-1/2	4-1/2
Distance Column to Spindle (in.)	10	10
Range of Spindle Speeds (RPM)	Low 60, 130, 230, 450, 800, 1500 High 120, 260, 460, 900, 1600, 3000	Low 60, 130, 230, 450, 800, 1500 High 120, 260, 460, 900, 1600, 3000
Number of Powerfeeds (GHD-20PF)	3	
Spindle Travel (in.) Manual	5	4-1/2
Spindle Travel (in.) Auto	N/A	4-1/4
Spindle Distance to Base (in.)	44-15/16	44-15/16
Spindle Distance to Table (max./in.)	30-1/2	30-1/2
Table Size (in.)	21-3/4 x 19-1/2	21-3/4 x 19-1/2
T-Slots Number and Size (in.)	2 & 5/8	2 & 5/8
T-Slot Centers (in.)	9	9
Work Table Weight Capacity (lbs.)	275	275
Spindle Taper	MT-3	MT-3
Base Dimensions (in./ LxWxH)	26 x 18 x 5	26 x 18 x 5
Base Work Table (in.)	15-1/4 x 13	15-1/4 x 13
Base Slots Number & Size (in.)	2 & 5/8	2 & 5/8
Motor	2HP, 230V, 3Ph, 2 Speed	2 HP, 230V, 3 Ph, 2 Speed
Overall Dimensions (in./ LxWxH)	32 x 24 x 71	33 x 29 x 76
Net Weight (lbs.)	660	660



354020



# 20" GEARED HEAD DRILLING AND TAPPING PRESSES

**2**  
YEAR  
WARRANTY

## FEATURES

- Heavy-duty design allows a variety of precision drilling and tapping applications
- Easy to read internal depth gauge
- Three power down feeds
- Calibrated fine down feed built-in
- Built-in spindle lock
- Head tilts left or right
- Easy accessible table raiser
- Large production table and T-slotted base

## STANDARD EQUIPMENT

- Integrated tapping and reversing controls
- T-slotted worktable
- Drill chuck arbor
- Draw bar
- TEFC Motor



354026

STOCK NUMBER	354022	354026
Model Number	GHD-20T	GHD-20PFT
Drilling Capacity Cast Iron (in.)	1-1/2	1-1/2
Drilling Capacity Mild Steel (in.)	1-1/4	1-1/4
Column Diameter (in.)	4-1/2	4-1/2
Distance Column to Spindle (in.)	10	10
Range of Spindle Speeds (RPM)	120, 260, 460, 900, 1600, 3000, 60, 130, 230, 450, 800, 1500	120, 260, 460, 900, 1600, 3000, 60, 130, 230, 450, 800, 1500
Spindle Travel (in.) Manual	5	4-1/2
Spindle Travel (in.) Auto	N/A	4-1/4
Spindle Distance to Base (in.)	44-5/16	44-5/16
Spindle Distance to Table (max./in.)	30-1/2	30-1/2
Table Size (in.)	21-3/4 x 19-1/2	21-3/4 x 19-1/2
T-Slots Number and Size (in.)	2 & 5/8	2 & 5/8
T-Slot Centers (in.)	9	9
Work Table Weight Capacity (lbs.)	275	275
Spindle Taper	MT-3	MT-3
Base Dimensions (in./ LxWxH)	26 x 18 x 5	26 x 18 x 5
Base Work Table (in.)	15-1/4 x 13	15-1/4 x 13
Base Slots Number & Size (in.)	2 & 5/8	2 & 5/8
Motor	2HP, 230V, 3Ph, 2-speed	2HP, 230V, 3Ph, 2-speed
Overall Dimensions (in./ LxWxH)	32 x 24 x 71	32 x 24 x 71
Net Weight (lbs.)	700	708

**JET**



# 20" GEARED HEAD DRILL PRESS



## FEATURES

- Helical gears for smooth, quiet operation
- Quick release drill ejector
- Safety latch to prevent head dropping when unclamped
- Eight spindle speeds
- T-Slotted table with coolant trough
- Head and table rotate 360 degrees around column
- 2 position High/Low switch
- 3-15/16" Column diameter
- English/Metric depth gauge



354027

STOCK NUMBER	354027	354028	354029	354030	354031
Model Number	J-A2608-1	J-A2608-2	J-A2608-4	J-A2608M-PF2	J-A2608M-PF4
Drilling Capacity Cast Iron (in.)	1-3/8	1-3/8	1-3/8	1-3/8	1-3/8
Drilling Capacity Mild Steel (in.)	1-1/4	1-1/4	1-1/4	1-1/4	1-1/4
Column Diameter (in.)	3-15/16	3-15/16	3-15/16	3-15/16	3-15/16
Distance Column to Spindle (in.)	10	10	10	10	10
Spindle Taper	MT-3	MT-3	MT-3	MT-3	MT-3
Range of Spindle Speeds (RPM)	Low-130, 260, 420, 840; High- 535, 1070, 1745, 3480	Low-130, 260, 420, 840; High-535, 1070, 1745, 3480	Low-130, 260, 420, 840; High-535, 1070, 1745, 3480	Low-130, 260, 420, 840; High-535, 1070, 1745, 3480	Low-130, 260, 420, 840; High-535, 1070, 1745, 3480
Spindle Travel (in.)	5-1/8	5-1/8	5-1/8	5-1/8	5-1/8
Spindle Distance to Base (in.)	44	44	44	44	44
Spindle Distance to Table (max./in.)	35-5/8	35-5/8	35-5/8	35-5/8	35-5/8
Table Size (in.)	15-3/4 x 19-3/4	15-3/4 x 19-3/4	15-3/4 x 19-3/4	15-3/4 x 19-3/4	15-3/4 x 19-3/4
Quill Feed	Auto	Auto	Auto	Auto	Auto
Quill Feed Rates (IPR)	.0004, .006, .009, .012	.0004, .006, .009, .012	.0004, .006, .009, .012	.0004, .006, .009, .012	.0004, .006, .009, .012
Quill Travel	5-1/8	5-1/8	5-1/8	5-1/8	5-1/8
Quill Diameter (in.)	2-3/8	2-3/8	2-3/8	2-3/8	2-3/8
Vertical Movement of Drill Head	8-5/8	8-5/8	8-5/8	8-5/8	8-5/8
Table Travel (in.)	24-1/2	24-1/2	24-1/2	24-1/2	24-1/2
T-Slots Number and Size (in.)	2 & 9/16	2 & 9/16	2 & 9/16	2 & 9/16	2 & 9/16
Work Table Weight Capacity (lbs.)	350	350	350	350	350
Base Dimensions (in./ LxWxH)	24 x 22	24 x 22	24 x 22	24 x 22	24 x 22
Motor	3/4 - 1HP, 115V, 1ph	1 - 1-1/2HP, 220V, 3ph	1 - 1-1/2HP, 440V, 3ph	1 - 1-1/2HP, 220V, 3ph	1 - 1-1/2HP, 440V, 3ph
Overall Dimensions (in./ LxWxH)	24 x 22 x 72	24 x 22 x 72	24 x 22 x 72	24 x 22 x 72	24 x 22 x 72
Net Weight (lbs.)	475	475	475	600	600

STOCK NUMBER	DESCRIPTION
5245631	Foot reversing switch*
1820061	5-speed forward/reverse switch*

\* 3 phase machines only





# 26" GEARED HEAD DRILL PRESS



## FEATURES

- Helical gears for smooth, quiet operation
- Quick release drill ejector
- English/Metric depth gauge
- Machined, T-Slotted base plate
- Head and table rotate 360° around column
- No-volt release prevents spindle start when power returns after shut down



STOCK NUMBER	354034	354035	354036	354037
Model Number	J-A3008-2	J-A3008-4	J-A3008M-PF2	J-A3008M-PF4
Drilling Capacity Cast Iron (in.)	1-3/8	1-3/8	1-3/8	1-3/8
Drilling Capacity Mild Steel (in.)	1-1/4	1-1/4	1-1/4	1-1/4
Quill Feed	Auto	Auto	Auto	Auto
Quill Travel (in.)	6	6	6	6
Quill Diameter (in.)	2-7/16	2-7/16	2-7/16	2-7/16
Range of Spindle Speeds (RPM)	90, 190, 320, 530, 640, 1060, 1790, 3610	90, 190, 320, 530, 640, 1060, 1790, 3610	90, 190, 320, 530, 640, 1060, 1790, 3610	90, 190, 320, 530, 640, 1060, 1790, 3610
Spindle Taper	MT-3	MT-3	MT-3	MT-3
Spindle Travel (in.)	6	6	6	6
Spindle Distance to Base (in.)	45-5/8	45-5/8	45-5/8	45-5/8
Spindle Distance to Table (max./in.)	35	35	35	35
Table Size (in.)	15-3/4 x 19-3/4	15-3/4 x 19-3/4	15-3/4 x 19-3/4	15-3/4 x 19-3/4
Table Travel (in.)	30	30	30	30
T-Slots Number and Size (in.)	2 & 9/16	2 & 9/16	2 & 9/16	2 & 9/16
Work Table Weight Capacity (lbs.)	450	450	450	450
Base Dimensions (LxWxH/ in.)	28 x 24	28 x 24	28 x 24	28 x 24
Base Slots Number & Size (in.)	2 & 9/16	2 & 9/16	2 & 9/16	2 & 9/16
Motor	1-1/2 - 2HP, 220V, 3ph	1-1/2 - 2HP, 440/460V, 3ph	1-1/2 - 2HP, 220V, 3ph	1-1/2 - 2HP, 440/460V, 3ph
Overall Dimensions (in./ LxWxH)	28 x 24 x 72	28 x 24 x 72	28 x 24 x 72	28 x 24 x 72
Net Weight (lbs.)	565	565	600	600



Made In Sweden



# 26" GEARED HEAD DRILL PRESS

**2**  
YEAR  
WARRANTY

## FEATURES

- Helical gears for smooth quiet operation
- Quick release drill ejector
- English/Metric depth gauge
- Machined, T-Slotted base plate
- Head and table rotate 360° around column
- No-volt release prevents spindle start when power returns after shut down

## STANDARD EQUIPMENT

- Fully enclosed spindle
- Large T-Slotted table

STOCK NUMBER	354040	354041
Model Number	J-A4008M-PF2	J-A4008M-PF4
Drilling Capacity Cast Iron (in.)	2	2
Drilling Capacity Mild Steel (in.)	1-7/8	1-7/8
Column Diameter (in.)	5-1/2	5-1/2
Distance Column to Spindle (in.)	13	13
Range of Spindle Speeds (RPM)	105, 162, 240, 360, 528, 805, 1175, 1800	105, 162, 240, 360, 528, 805, 1175, 1800
Spindle Travel (in.)	8	8
Spindle Distance to Base (in.)	44	44
Spindle Distance to Table (max./in.)	33	33
Table Size (in.)	20 x 24	20 x 24
Table Travel (in.)	25	25
T-Slots Number and Size (in.)	2 & 5/8	2 & 5/8
T-Slot Centers (in.)	8-1/4	8-1/4
Work Table Weight Capacity (lbs.)	550	550
Spindle Taper	MT-4	MT-4
Base Dimensions (in./ LxWxH)	23 x 28	23 x 28
Base Work Table (in.)	13 x 16-1/8	13 x 16-1/8
Base Slots Number & Size (in.)	2 & 5/8	2 & 5/8
Motor	3HP, 220V, 3Ph	3HP, 440/460V, 3Ph
Overall Dimensions (in./ LxWxH)	23 x 28 x 81	23 x 28 x 81
Net Weight (lbs.)	700	820



Made In Sweden



354040



# 26" GEARED HEAD DRILL PRESSES



## FEATURES

- Direct drive round column drill press with mechanical clutch
- Two speed forward and reverse switch
- Mechanical powerfeed clutch engagement
- Heavy duty quill and spindle
- Tempered, ground spindle with internal taper mounted in precision bearings for maximum accuracy, minimizing deflection
- Speed and feed selectors are located on one side of the drill head for convenience and ease of operation
- Oversized base is precision ground with T-slots for added versatility and stability

## STANDARD EQUIPMENT

- Automatic tool ejector
- Manual quill lock
- Coolant system
- Low voltage at switch

STOCK NUMBER	354050	354051	354052
Model Number	J-2350	J-2360	J-2380
Drilling Capacity Cast Iron (in.)	1-7/8	2-5/32	2-7/8
Drilling Capacity Mild Steel (in.)	1-3/4	2	2-3/4
Distance Column to Spindle (in.)	14	15	16-1/2
Range of Spindle Speeds (RPM)	82, 120, 180, 240, 354, 528, 678, 1026, 1524	55, 98, 156, 198, 346, 456, 576, 822, 1338	42, 58, 86, 116, 154, 249, 304, 412, 554, 748, 1098, 1458
Spindle Travel (in.)	9	10	11
Spindle Distance to Base (in.)	49	50	51
Spindle Distance to Table (max./in.)	30-1/2	30-1/2	30-1/2
Table Size (in.)	22 x 19	22 x 19	23-1/2 x 23-1/2
T-Slots Number and Size (in.)	2 & 5/8	3 & 5/8	3 & 5/8
Work Table Weight Capacity (lbs.)	400	400	400
Spindle Taper	MT-4	MT-4	MT-5
Base Dimensions (in./ LxWxH)	102 x 25 x 47	108 x 30 x 53	114 x 33 x 54
Base Slots Number & Size (in.)	3 & 5/8	3 & 5/8	3 & 5/8
Motor	3HP, 230/460V, 3 Ph, Prewired 230V	4HP, 230/460V, 3 Ph, Prewired 230V	7-1/2HP, 230/460V, 3 Ph, Prewired 230V
Floor Space Required (in./ LxWxH)	40 x 30 x 95	53 x 30 x 108	55 x 33 x 110
Net Weight (lbs.)	1810	2405	3065



Made In Spain





# RADIAL DRILL PRESS

The apex of heavy-duty drill presses; JET Radial Arm Drill Presses are built to handle huge pieces, create precision holes and enhance productivity in even the busiest commercial shops. Power spindle feed and coolant systems enhance operation, safety features and ergonomic design, JET Radial Arm Drill Presses are built to withstand the heaviest drilling and hold material fast for precision performance.



## 3' ARM RADIAL DRILL PRESS

### FEATURES

- The power train gears and spline shafts are made of the finest quality, heat treated and ground nickel-chrome steel, giving extra strength and smoothness to high torque loads
- The spindle is made of finest case hardened steel, for extra strength and wear
- The spindle is supported by double row taper roller and thrust ball bearings at the nose, with thrust and radial axis bearings at the top
- Built to withstand exceptionally heavy drilling and boring loads to insure maximum accuracy

### STANDARD EQUIPMENT

- Built in work light
- Coolant pump
- Tool kit
- Box table

**2**  
YEAR  
WARRANTY

STOCK NUMBER	320033
Model Number	J-720R
Drilling Capacity Mild Steel (in.)	1-1/2
Drilling Capacity Cast Iron (in.)	2
Tapping Capacity Mild Steel (in.)	3/4
Tapping Capacity Cast Iron (in.)	1
Boring Capacity Steel (in.)	2-3/8
Boring Capacity Cast Iron (in.)	4
Column Diameter (in.)	8-1/4
Distance Column to Spindle (min/in.)	8-5/8
Distance Column to Spindle (max/in.)	29-1/2
Travel of Head Horizontal (in.)	20-7/8
Distance Base to Spindle (min/in.)	9-5/8
Distance Base to Spindle (max/in.)	41-3/4
Arm Travel Vertical (in.)	23-13/16
Table Dimensions (in.)	23-5/8 X 17-1/2 X 15
Base Dimensions (in.)	49-5/8 x 25-3/16 x 6-1/4
Quill Travel (in.)	8-21/32
Spindle Taper	MT-4
Quill Travel w/ Powerfeed engaged (in.)	8-1/4
Number of Spindle speeds (RPM)	6 (88 - 1500)
Quill Down feed Rates (IPR)	.002, .004, .006
Motor	3HP, 230/460V 3Ph, Prewired 230V
Elevating Motor	1 HP
Coolant Pump Motor	1/8 HP
Machine Height from Floor (in.)	85-7/16
Overall Dimensions (in./ LxWxH)	64 x 32 x 85
Net Weight (lbs.)	2697



**DRILLING**



# 4' ARM RADIAL DRILL PRESSES

## FEATURES

- The power train gears and spline shaft are made of the finest quality, heat treated and ground nickel-chrome steel, giving extra strength and smoothness to high torque loads
- The spindle is made of the finest case hardened steel for extra strength and wear
- The spindle is supported by double row taper roller and thrust ball bearings at the nose with trust and radial axis bearings at the top
- The spindle is built to withstand exceptionally heavy drilling and boring loads and to insure maximum accuracy
- Push button controls are all reduced to 110V
- Electrical circuits are located in the built-in control box at the rear of the arm- this keeps the controls dust and humidity free while making them easily accessible for maintenance.
- Entire frame is made of Meehanite and high tensile strength cast iron to handle the heaviest of jobs
- Arm raising safety device prevents arm from dropping
- Counter balanced mechanism for spindle return
- 12 speeds/3 feed rates make exotic materials easier to drill, bore and tap
- Centralized control center
- Automatic tool ejector
- Independent arm manual clamping system, which locks and unlocks the head and column

## STANDARD EQUIPMENT

- Built in work light
- Coolant pump
- Tool kit
- Box table

STOCK NUMBER	320034	320035
Model Number	J-1100R	J1100R-4
Drilling Capacity Mild Steel (in.)	1-3/4	1-3/4
Drilling Capacity Cast Iron (in.)	2-1/4	2-1/4
Tapping Capacity Mild Steel (in.)	1	1
Tapping Capacity Cast Iron (in.)	1-1/4	1-1/4
Boring Capacity Steel (in.)	3-3/8	3-3/8
Boring Capacity Cast Iron (in.)	4-3/4	4-3/4
Column Diameter (in.)	10-1/4	10-1/4
Distance Column to Spindle (min/in.)	9-5/8	9-5/8
Distance Column to Spindle (max/in.)	43-5/16	43-5/16
Travel of Head Horizontal (in.)	32-1/4	32-1/4
Distance Base to Spindle (min/in.)	18-1/2	18-1/2
Distance Base to Spindle (max/in.)	50	50
Arm Travel Vertical (in.)	22-7/16	22-7/16
Table Dimensions (in.)	24-3/4 x 20-1/2 x 16-1/2	24-3/4 x 20-1/2 x 16-1/2
Base Dimensions (in.)	67-3/4 x 28 x 6-1/2	67-3/4 x 28 x 6-1/2
Quill Travel (in.)	9	9
Spindle Taper	MT-4	MT-4
Quill Travel w/ Powerfeed engaged (in.)	8-21/32	8-21/32
Number of Spindle speeds (RPM)	12 (44-1500)	12 (44 - 1500)
Quill Down feed Rates (IPR)	3 (.002, .004, .006)	3 (.002, .004, .006)
Motor	1-1/2 to 3HP, 230V, 3 Ph	1-1/2 to 3HP, 460V, 3 Ph
Elevating Motor	1HP	1HP
Coolant Pump Motor	1/8HP	1/8HP
Machine Height from Floor (in.)	100	100
Overall Dimensions (in./ LxWxH)	74 x 34 x 89	74 x 34 x 89
Net Weight (lbs.)	4190	4190



**JET**



# 4' ARM RADIAL DRILL PRESSES

**2**  
YEAR WARRANTY

## FEATURES

- The power train gears and spline shaft are made of the finest quality, heat treated and ground nickel-chrome steel, giving extra strength and smoothness to high torque loads
- The spindle is made of the finest case hardened steel for extra strength and wear
- The spindle is supported by double row taper roller and thrust ball bearings at the nose, with thrust and radial axis bearings at the top
- The spindle is built to withstand exceptionally heavy drilling and boring loads and to insure maximum accuracy
- Push button controls are all reduced to 110V
- Arm raising safety device prevents arm from dropping

## STANDARD EQUIPMENT

- Built in work light
- Coolant pump
- Tool kit
- Box table



320036

STOCK NUMBER	320036	320037
Model Number	J-1230R	J-1230R-4
Drilling Capacity Mild Steel (in.)	1-7/8	1-7/8
Drilling Capacity Cast Iron (in.)	2-5/16	2-5/16
Tapping Capacity Mild Steel (in.)	1	1
Tapping Capacity Cast Iron (in.)	1-1/2	1-1/2
Boring Capacity Steel (in.)	3-3/8	3-3/8
Boring Capacity Cast Iron (in.)	4-3/4	4-3/4
Column Diameter (in.)	11-13/16	11-13/16
Distance Column to Spindle (min/in.)	13-3/4	13-3/4
Distance Column to Spindle (max/in.)	46	46
Travel of Head Horizontal (in.)	35	35
Distance Base to Spindle (min/in.)	19-3/8	19-3/8
Distance Base to Spindle (max/in.)	54	54
Arm Travel Vertical (in.)	35	35
Table Dimensions (in.)	25 x 20-1/2 x 16-5/16	25 x 20-1/2 x 16-5/16
Base Dimensions (in.)	67-3/4 x 28 x 7	67-3/4 x 28 x 7
Quill Travel (in.)	9-7/8	9-7/8
Spindle Taper	MT-4	MT-4
Quill Travel w/ Powerfeed engaged (in.)	9-7/16	9-7/16
Number of Spindle speeds (RPM)	12 (44 - 1500)	12 (44 - 1500)
Quill Down feed Rates (IPR)	3 (.002, .004, .006)	3 (.002, .004, .006)
Motor	2-1/2 to 5HP, 230V, 3 Ph	2-1/2 to 5HP, 460V, 3 Ph
Elevating Motor	1HP	1HP
Coolant Pump Motor	1/8HP	1/8HP
Machine Height from Floor (in.)	109-1/2	109-1/2
Overall Dimensions (in./ LxWxH)	80 x 39 x 89	80 x 39 x 89
Net Weight (lbs.)	4520	5070



# 5' ARM RADIAL DRILL PRESS

## FEATURES

- The power train gears and spline shaft are made of the finest quality, heat treated and ground nickel-chrome steel, giving extra strength and smoothness to high torque loads
- The spindle is made of the finest case hardened steel for extra strength and wear
- The spindle is supported by double row taper roller and thrust ball bearings at the nose, with thrust and radial axis bearings at the top
- The spindle is built to withstand exceptionally heavy drilling and boring loads and to insure maximum accuracy
- Push button controls are all reduced to 110V
- Electrical circuits are located in the built-in control box at the rear of the arm- this keeps the controls dust and humidity free while making them easily accessible for maintenance
- Entire frame is made of Meehanite and high tensile strength cast iron to handle the heaviest of jobs
- Arm raising safety device prevents arm from dropping
- Counter balanced mechanism for spindle return
- 12 speeds/3 feed rates make exotic materials easier to drill, bore and tap
- Centralized control center
- Automatic tool ejector
- Hydraulic head and column clamping

## STANDARD EQUIPMENT

- Built in work light
- Coolant pump
- Tool kit
- Box table



320038

STOCK NUMBER	320038	320039
Model Number	J-1600R	J-1600R-4
Drilling Capacity Mild Steel (in.)	2-1/2	2-1/2
Drilling Capacity Cast Iron (in.)	2-5/16	2-7/8
Tapping Capacity Mild Steel (in.)	2	2
Tapping Capacity Cast Iron (in.)	2-3/8	2-3/8
Boring Capacity Steel (in.)	5	5
Boring Capacity Cast Iron (in.)	7-3/8	7-3/8
Column Diameter (in.)	17	17
Distance Column to Spindle (min/in.)	13-3/8	13-3/8
Distance Column to Spindle (max/in.)	62-1/4	62-1/4
Travel of Head Horizontal (in.)	44-7/8	44-7/8
Distance Base to Spindle (min/in.)	15	15
Distance Base to Spindle (max/in.)	63	63
Arm Travel Vertical (in.)	33-15/32	33-15/32
Table Dimensions (in.)	27-7/8 x 19-5/8 x 15-3/4	27-7/8 x 19-5/8 x 15-3/4
Base Dimensions (in.)	97-5/8 x 41-11/32 x 8-1/4	97-5/8 x 41-11/32 x 8-1/4
Quill Travel (in.)	14-9/16	14-9/16
Spindle Taper	MT-5	MT-5
Quill Travel w/ Powerfeed engaged (in.)	13	13
Number of Spindle speeds (RPM)	12 (40 - 1920)	12 (40 - 1920)
Quill Down feed Rates (IPR)	6 (.003 - .038 IPR)	6 (.003 - .038 IPR)
Motor	7-1/2HP, 230/460V, 3Ph, Prewired 230V	7-1/2HP, 460V, 3Ph
Elevating Motor	2HP	2HP
Coolant Pump Motor	1/8HP	1/8HP
Machine Height from Floor (in.)	125	125
Overall Dimensions (in./ LxWxH)	116 x 55 x 112	112 x 55 x 116
Net Weight (lbs.)	11000	11000



**JET**





## TAPER MOUNT DRILL CHUCKS

- All components are heat-treated high grade alloy steel
- Chuck jaws are precision fitted to withstand 115 PSI of torque
- All models meet JIS specifications: B4634E



STOCK NUMBER	TDC-375	TDC-500	TDC-501	TDC-625	TDC-750
Model Number	561702	561704	561706	561708	561709
Capacity (in.)	0 - 3/8	0 - 1/2	0 - 1/2	1/8 - 5/8	1/8 - 3/4
Taper Mount	JT-2	JT-3	JT-33	JT-3	JT-4
Body Diameter (in.)	1-15/32	1-5/8	1-25/32	2-3/16	2-7/8
Overall Length (in.)	2-3/8	2-31/32	3-1/8	3-11/16	5



**DRILLING**



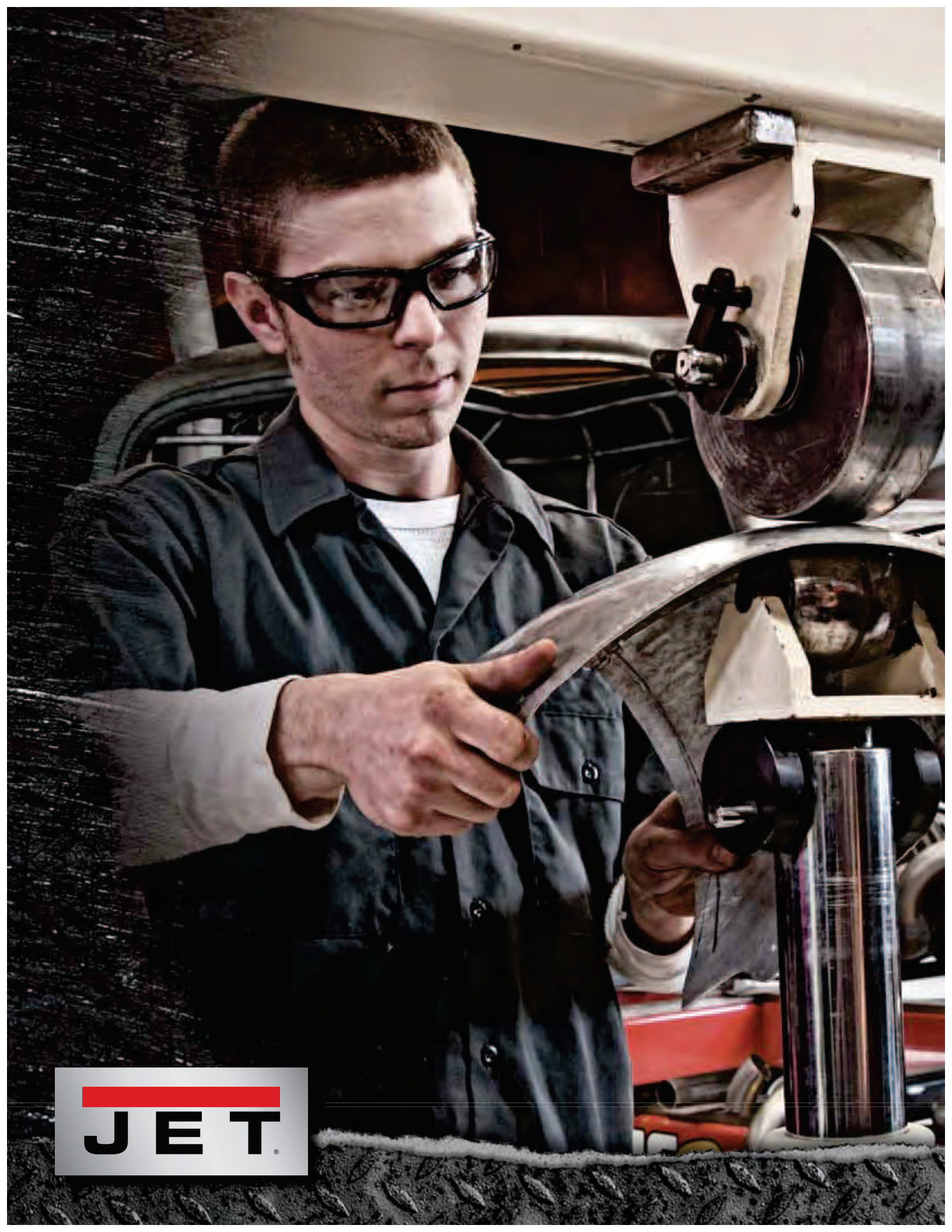

**J E T**





# FORMING

The decision to add JET metalforming equipment to your operation is an indication that you demand precision and accuracy from a reliable machine. High-quality JET brakes, shears, rolls, English Wheel, Planishing Hammer, presses and notchers provide you with added capabilities to expand your operation and enhance every project. Professional manuals ensure efficient operation and our industry-leading TWO-year warranty backs every JET machine you purchase.

**PRECISION &  
ACCURACY  
FROM  
RELIABLE  
MACHINES**



# SHEARS

When precision cuts and true edges are vital to production results do not compromise the efficiency of your shop. JET Foot Shears are effective on a number of materials including steel, aluminum, brass, copper, lead, plastic and zinc. Two-way upper blade configuration provides double the cutting life. JET Portable Shears, capable of shearing sheet steel, steel bars and rods, and many non-metallic materials, allow you to take JET reliability and power to the worksite.



## PORTABLE SHEARS

### FEATURES

- Capable of shearing sheet steel, steel bars and rods plus many non-metallic materials
- Replaceable high quality stainless steel blades are hardened and tempered for maximum service life
- An adjustable hold down clamp aids in securing material
- Compound leverage allows the operator to easily perform work within shears' rated capacity
- Includes 35-1/2" handle

STOCK NUMBER	754108K	754112K
Model Number	SS-8N	SS-12N
Sheet Capacity (Mild Steel/in.)	3/16	1/8
Flat Capacity (Mild Steel/in.)	2-3/4 x 1/4	2-3/8 x 5/32
Round Capacity (Mild Steel/in.)	1/2	1/2
Cutting Blade Length (in.)	8	11-3/4
Overall Dimensions (in./ L x W x H)	15 x 6 x 16	20 x 6 x 17
Net Weight (lbs.)	54	75



754112K





# FOOT SHEARS

## FEATURES

- Ideal for precision shearing of mild steel up to 16 gauge
- Two-way blade configuration provides twice the cutting life
- Upper blade is two-way; bottom blade is one-way
- 2° angle cutting edge; 1° face relief

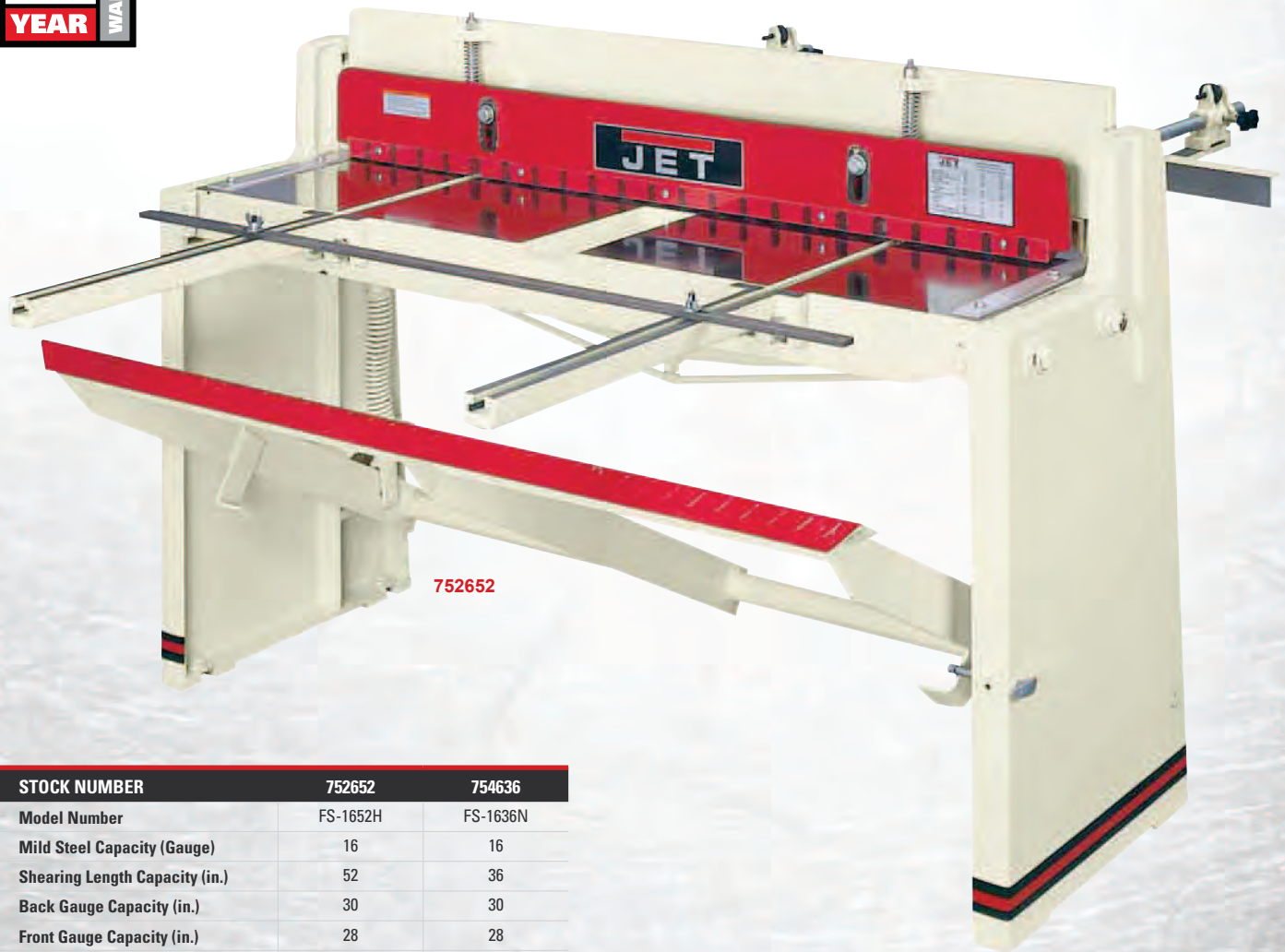

STOCK NUMBER	752652	754636
Model Number	FS-1652H	FS-1636N
Mild Steel Capacity (Gauge)	16	16
Shearing Length Capacity (in.)	52	36
Back Gauge Capacity (in.)	30	30
Front Gauge Capacity (in.)	28	28
Overall Dimensions (in./ L x W x H)	63 x 74 x 42	46 x 74 x 42
Net Weight (lbs.)	1,014	816

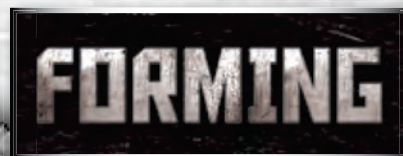



# 52" PNEUMATIC SHEAR



## FEATURES

- Hi-quality cast-iron grade frame to eliminate deflection across the blade-span and blade framework
- Low cutting angle to cut narrow strips without twisting
- Precise bed and beam alignment assures working accuracy
- Adjustable working bed for correct setup according to the blade clearance
- Complete set of pneumatic control system
- 16 gauge maximum cutting capacity for mild-steel
- 12-14 gauge maximum cutting capacity for aluminum and copper alloys

**NEW!**



### STOCK NUMBER

755203

Model Number	PS-1652E
Max. Soft Alloy Capacity (Gauge)	12 - 14
Mild Steel Capacity (Gauge)	16
Shearing Length Capacity (in.)	52
Back and Front Gauge Capacity (in.)	28-1/2 and 28
Strokes per Minute (Full Length)	40
Air Consumption per Minute (CFM)	1.3
Air Consumption (CFM)	25.3
Overall Dimensions (in./ L x W x H)	60 x 24 x 43
Net Weight (lbs.)	1,048



Pneumatic Controls Now Makes Shearing A One Man Job

**JET**



# COMBINATION SHEAR, BRAKE AND ROLL

## FEATURES

- Combination shear, brake and roll in one compact machine
- Right or left hand operation
- Shear can be used for mild steel, aluminum, brass, copper, lead, plastic and zinc
- Brake is equipped with easily removable fingers that permit angle, channel, box and other complex bending operations
- Slip rolls are precision turned and ground with wire grooves

## STANDARD EQUIPMENT

- Set of male dies
- One set of female dies
- Dual edge shear blade
- Spring-loaded work hold down
- Back gauge

STOCK NUMBER	754031	754041
Model Number	SBR-30N	SBR-40N
Mild Steel Capacity (Gauge/in.)	20/30	20/40
Shearing Capacity (Gauge/in.)	20/30	20/40
Bending Capacity (Gauge/in.)	20/30	20/40
Rolling Capacity (Gauge/in.)	20/30	20/40
Size of Slip Roll (in./ L x Dia.)	30 x 1-1/2	40 x 1-5/8
Width of Upper Dies (in.)	1, 2, 3, 6, 8, 10	1, 1-1/2, 2, 2-1/2, 4, 7, 10, 12
Upper Die Height (in.)	4-11/16	4
Min. Forming Radius (in.)	3/4	1
Wire Grooves (in.)	1/8, 3/16, 9/32	3/16, 9/32, 3/8
Base Dimensions (in./ L x W x H)	14 1/2 x 32-3/8	16-1/2 x 43
Overall Dimensions (in./ L x W x H)	40 x 16 x 24	56 x 23 x 30
Net Weight (lbs.)	290	575



754031

OPTIONAL EQUIPMENT	STOCK NUMBER
Floor Stand for SBR-30N	754030
Floor stand for SBR-40N	754040



754030



Brake



Shear



Roll





# BRAKES

To accommodate the amount of space in your shop, as well as forming and shaping needs of your operation JET Bench and Floor Model Hand Brakes, Bench Model Box and Pan Brakes, and Floor Model Box and Pan Brakes are designed to offer superior versatility, strength, accuracy and durability. Finger width assortments and removable finger sections enhance overall productivity in your facility. JET Brakes are built rugged to provide superior satisfaction bend after bend.



## BENCH AND FLOOR MODEL HAND BRAKES

### BENCH MODEL HAND BRAKES

- Suitable for many types of metalforming operations
- All body sections are welded steel plate
- Heavy truss rods and braces are designed to give superior strength
- Precise bed and beam alignment assures working accuracy

### FLOOR MODEL HAND BRAKES

- Simplicity of design, improved truss rod construction and a minimum number of moving parts make the JET hand brake easy to operate
- All body sections are welded steel plate with heavy truss rods and braces designed to give greater strength and durability
- Both the bed and apron are bored in line to assure the utmost in accuracy

**2**  
YEAR WARRANTY



754222

STOCK NUMBER (BENCH)	754216	754222
Model Number	HB-1648N	HB-2248N
Mild Steel Capacity (Gauge)	16	22
Maximum Lift of Beam (in.)	1-1/4	7/8
Bending Length Capacity (in.)	48	48
Beam Adjustment (in./front to rear)	5/8	1/8
Overall Dimensions (in./ L x W x H)	61 x 21 x 28	61 x 21 x 26
Net Weight (lbs.)	342	190

STOCK NUMBER (FLOOR)	752002
Model Number	HB-1697H
Mild Steel Capacity (Gauge)	16
Maximum Lift of Beam (in.)	2-1/4
Bending Length Capacity (in.)	97
Beam Adjustment (in./front to rear)	1
Overall Dimensions (in./ L x W x H)	120 x 31 x 57
Net Weight (lbs.)	2,290

OPTIONAL EQUIPMENT	STOCK NUMBER
Floor Stand for HB-2248N & HB-1648N	754200





# BENCH MODEL BOX AND PAN BRAKES

## FEATURES

- Incorporates all the features of our standard brakes but with greater range of applications
- With fingers installed it can be used as a full-length nose bar, turning the machine into a straight bending brake
- Sectioned fingers are easily removed for box bending and special forming operations

## STANDARD EQUIPMENT

- Total of 16 assorted size section fingers

STOCK NUMBER	752116	754122
Model Number	BP-2248N	BP-1648H
Mild Steel Capacity (Gauge)	16	22
Bending Length Capacity (in.)	48	48
Maximum Lift of Beam (in.)	1-1/4	7/8
Maximum Box Depth (in.)	4	3
Beam Adjustment (in./front to rear)	5/8	1/8
Number and Width of Fingers (in.)	5@2, 6@3, 5@4	5@2, 6@3, 5@4
Finger Nose Angle (deg.)	45	45
Nose Radius (in.)	1/32	1/32
Overall Dimensions (in./ L x W x H)	75 x 19 x 34	61 x 31 x 28
Net Weight (lbs.)	430	258



754122





# FLOOR MODEL BOX AND PAN BRAKES

## FEATURES

- Wide assortment of finger widths allow greater versatility in the shop
- All body sections are welded steel plate with heavy truss rods and braces designed to give greater strength and durability
- Both the bed and apron are bored in line to assure the utmost accuracy

**2**  
YEAR  
WARRANTY

STOCK NUMBER	754100	752102
Model Number	BP-1248N	BP-1696H
Mild Steel Capacity (Gauge)	12	16
Bending Length Capacity (in.)	48	96
Maximum Lift of Beam (in.)	1-1/2	2-1/4
Maximum Box Depth (in.)	4	4
Beam Adjustment (in./front to rear)	7/8	1
Number and Width of Fingers (in.)	5@3, 2@4, 5@5	5@3, 6@4, 9@5, 2@6
Finger Nose Angle (deg.)	45	45
Nose Radius (in.)	1/32	1/32
Overall Dimensions (in./ L x W x H)	70 x 34 x 52	142 x 32 x 61
Net Weight (lbs.)	1,477	1,985



752102

**JET**



# SLIP ROLLS

## FEATURES

- Suitable for many industrial, educational and vocational shop uses
- Precision turned carbon steel rolls that are ground and polished
- Large roll adjusting screws facilitate lifting upper roll for easy material removal

## STANDARD EQUIPMENT

- Wire grooves are standard on SR-2024N, SR-2236N and SR-1650N

STOCK NUMBER	754020	754026	754050
Model Number	SR-2024N	SR-2236N	SR-1650N
Mild Steel Capacity (Gauge/in.)	20	22	16
Max. Forming Length (in.)	24	36	50
Number and Diameter of Rolls	3 and 2	3 and 2	3 and 3
Min. Forming Radius (in.)	1	1	2
Wire Grooves (in.)	3/16, 1/4, 5/16	3/16, 1/4, 5/16	1/4, 5/16, 3/8
Overall Dimensions (in./ L x W x H)	50 x 14 x 14	62 x 14 x 14	67 x 16 x 20
Net Weight (lbs.)	216	256	565



754020



## FLOOR STANDS FOR BENCH MODEL METAL FORMING MACHINES

We offer stands that fit our bench model hand brakes, box & pan brakes, slip rolls and combination shear, brake and rolls.



754200

STOCK NUMBER	754200	754024	754030	754036	754040	754051
Model Number	S-48N	SRS-24N	SRS-30N	SRS-36N	SRS-40N	SRS-50N
Fits	BP-2248N, BP-1648N, HB-224N8, HB-1648N	SR-2024N	SBR-30N	SR-2236N	SBR-40N	SR-1650N (Open Pedestal Style)
Overall Dimensions (in./ L x W x H)	56-1/2 x 18-1/4 x 28	30 x 14 x 28	40 x 16 x 24	42 x 14 x 28	49 x 21 x 30	68 x 22 x 30
Net Weight (lbs.)	85	35	45	51	82	70





# 50" ELECTRICAL POWER SLIP ROLL

**2**  
YEAR WARRANTY

**NEW!**

## FEATURES

- Valuable machine tool for sheet metal forming in HVAC- and FAB-shops
- Three-roll machine with two driven rolls.
- Rolls are made of hardened polished high-carbon steel.
- 1HP, 230/460V, 3Ph motor is prewired for 230V.
- Heavy duty frame and base insure precise sheet metal rolling.
- Easy to setup and operation.
- Forming roll has attached position scale for equal pressure adjustment.
- Weight and rigidity; scale and precision; strength and simplicity define exceptional comfort and ease of operation.
- Convenient foot-control assembly with emergency-button.
- All electrical and rotating parts are designed for safety and comfortable operation during machine use.



STOCK NUMBER	754028
Model Number	ESR-1650
Mild Steel Capacity (Gauge/in.)	16
Max. Forming Length (in.)	50
Number and Diameter of Rolls	3 rolls x 3 in. diameter
Min. Forming Radius (in.)	2
Wire Grooves (in.)	1/4, 5/16, 3/8
Overall Dimensions (in./ L x W x H)	67 x 42 x 20
Net Weight (lbs.)	810



Valuable Tool for HVAC And FAB Shops

**JET**



# ROTARY MACHINE

**2**  
YEAR WARRANTY

## FEATURES

- Long throat makes unit highly versatile
- Performs burring, edging, elbowing, flanging, flattening and turning
- Adjustable roll pressure by means of top mounted hand crank
- Can be used in both forward and reverse
- Operation is smooth, fast and precise
- Table mount with clamp is standard
- Six interchangeable rolls with 27/32" I.D.



754022

STOCK NUMBER	754022
Model Number	RM-22N
Distance Between Shaft Centers (in.)	2
Frame Throat Depth (in.)	7
Overall Dimensions (in./ L x W x H)	18 x 8 x 16
Cutting Capacity (Gauge)	22
Net Weight (lbs.)	64

# HAND NOTCHER

## FEATURES

- Made of cast iron
- Capable of notching virtually any shearable material
- Can notch angles of more than 90° through a two-step process
- Easy-to-read front gauges
- Heavy-duty cutting blade



754016

STOCK NUMBER	754016
Model Number	HN-16N
Cutting Capacity (Gauge)	16
Piercing Capacity (Gauge)	18
Maximum Notch (in.)	6 x 6
Stroke (in.)	3/4
Overall Dimensions (in./ L x W x H)	24 x 21 x 26
Net Weight (lbs.)	165

STOCK NUMBER	DESCRIPTION
754017	Stand

**FORMING**



# 24" PROFESSIONAL PLANISHING HAMMER

**2**  
YEAR WARRANTY

**NEW!**

## FEATURES

- Smooths beads and forms mild steel sheet metal up to 16 gauge
- Smooths beads and forms aluminum and copper up to 1/8" thick
- Machine is supplied with an upper and anvil die set
- 3-Position airflow regulates speeds of pneumatic hammer
- Machine controlled with 110V foot control
- 2-Die Set Brackets
- Quick change of upper dies



**JET Added Wheels and Handle for Ease of Movement in Your Shop**

STOCK NUMBER	756120
Model Number	PH-24
Frame Tube Sizes (in.)	4 x 4
Throat (in.)	24
Head Opening (in.)	2-1/2
Maximum Pressure (psi)	90
Air Consumption (CFM)	8.8
3-Speed Regulator (hits per min.)	4,400 - 4,800 / 3,200 - 3,500 / 1,800 - 2,000
Noise Level (dB)	92.26 - 104.3
Net Weight (lbs.)	220

**JET**



# 45" PROFESSIONAL ENGLISH WHEEL

## FEATURES

- Rolls beads and forms mild steel sheet metal up to 16 gauge
- Rolls beads and forms aluminum and copper up to 1/8" thick
- Machine supplied with 10 anvils and 4 rolling wheels
- Three sets of popular fender groove shaping wheels
- Screw lift assembly designed for comfortability and precise pressure setup
- Quick cam handle releases the work piece
- Both wheels swivel 90°
- Quick wheel change without using any tooling
- Wheels supplied with sealed bearings for smooth operation
- Heavy duty frame
- Storage brackets for rolling and anvil wheels
- Throat 45"
- Rolling wheels 6" diameter

**NEW!**



45" Deep Throat Depth Makes it Easy to Work with Large Panels

<b>STOCK NUMBER</b>	<b>756150</b>
Model Number	WH-45
Frame Tube Sizes (in.)	4 x 4
Throat (in.)	45
Head Opening (in.)	6
Head and Anvil Sit Swivel (deg.)	90
Rolling Wheels Diameter (in.)	6
Overall Dimensions (in./ L x W x H)	64 x 31 x 58
Net Weight (lbs.)	458



# MANUAL HYDRAULIC PIPE BENDERS



## FEATURES

- Simple manual operation for ease of use
- Six bending dies included standard for 2" (1/2", 3/4", 1", 1-1/4", 1-1/2", 2")
- Eight bending dies included standard for 3" (1/2", 3/4", 1", 1-1/4", 1-1/2", 2", 2-1/2", 3")
- Rotating stand locks in three positions for stability and versatility
- Heavy-duty hydraulic cylinder capable of bending schedule 40 pipe
- Completely manual so external power is not needed

STOCK NUMBER	331900	331910
Model Number	JHPB-20	JHPB-30
Pipe Size Capacity (in.)	1/2-2	1/2-3
Max. Pipe Wall Thickness (in.)	1/5	6/25
Maximum Load (tons)	9	20
Piston Stroke (in.)	10-1/4	12-5/8
Ram Diameter (in.)	1-3/4	2-1/3
Overall Dimensions (in./ L x W x H)	40 x 26 x 28-3/4	40 x 35 x 28-3/4
Net Weight (lbs.)	115	260



**JET**



# ARBOR PRESSES

## FEATURES

- For all production and assembly applications
- Precision cut steel rams and pinions for accurate operation
- Tables and slotted table-plates are flat and parallel to provide accurate support



STOCK NUMBER	333605	333610	333620	333630	333650
Model Number	AP-0	AP-1	AP-2	AP-3	AP-5
Diameter of Work (in.)	6-5/8	8	11-3/8	10-3/4	17
Capacity Over Table (in.)	4	5	7-3/8	11-3/8	18
Size of Ram Face (in.)	3/4 x 7-7/8	1 x 9-1/8	1-1/4 x 13	1-1/2 x 18	2 x 27-1/2
Approx. Pressure (tons)	1/2	1	2	3	5
Ram Bore (in.)	3/8	3/8	1/2	1/2	1/2
Height (in.)	10.9	12	16-1/4	21-1/2	35
Base Size (in.)	4 x 9-1/2	5 x 10-3/4	6-3/8 x 17	8-1/2 x 18	9-7/8 x 26
Net Weight (lbs.)	19	27	68	108	262





# HYDRAULIC SHOP PRESSES

**2**  
YEAR WARRANTY

## FEATURES

- For pressing, bending and straightening operations
- Easy-to-use, hand-operated with pressure gauge for direct pressure readings
- Tables raise and lower easily with use of hand crank on the 15-, 35-ton models
- Side frames are open for inserting long material
- Fast setup ram extension screw
- Ram moves laterally for added versatility (15- and 35-ton models)

## STANDARD EQUIPMENT

- Two bed plates and pump handles
- Straightness testing support uses centers or v-blocks on the 15-, 35-ton models

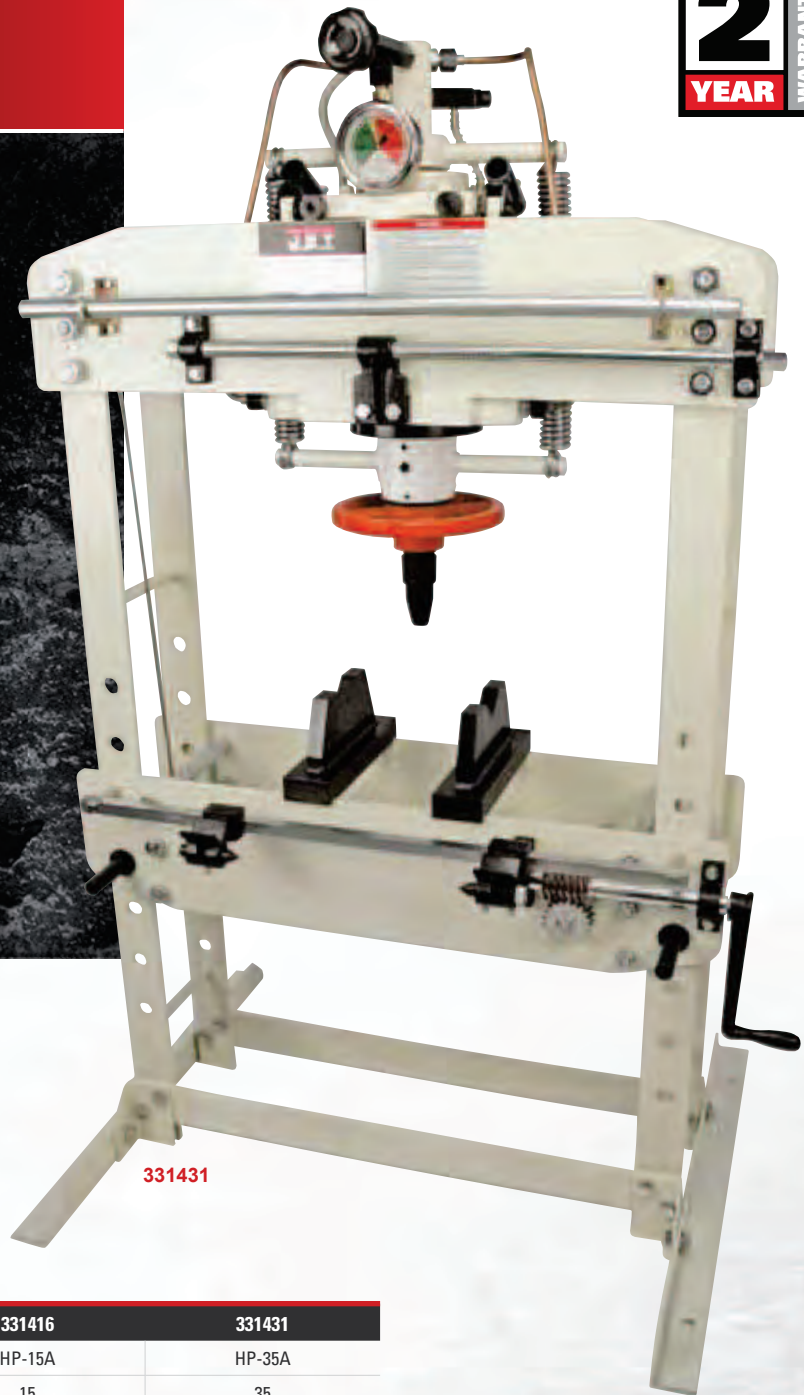

331431

STOCK NUMBER	331406	331416	331431
Model Number	HP-5A	HP-15A	HP-35A
Capacity (tons)	5	15	35
Ram Diameter (in.)	1-3/4	2-1/2	3
Piston Stroke (in.)	4	4-1/2	4-3/4
Screw Stroke (in.)	3	3-1/8	4
Work Table Size (in.)	19 x 5-1/2	24-3/4 x 7-1/2	31 x 10-3/8
Lateral Movement (in.)	N/A	10-3/16	15
Vertical Table Travel (in.)	15-3/4	22-3/16	23-5/8
Overall Dimensions (in./ L x W x H)	24 x 26 x 52	34 x 30 x 66	43 x 34 x 69
Net Weight (lbs.)	192	435	783

**JET**





**JET**

**WARNING**  
Read the manual before use.  
Always use proper technique.

**WARNING**  
High speed rotating parts.  
Keep hands and feet clear of the work area.

**WARNING**  
Use proper technique.  
Always use proper technique.

**CAUTION**  
Wear eye protection.  
Wear ear protection.

# FORMING



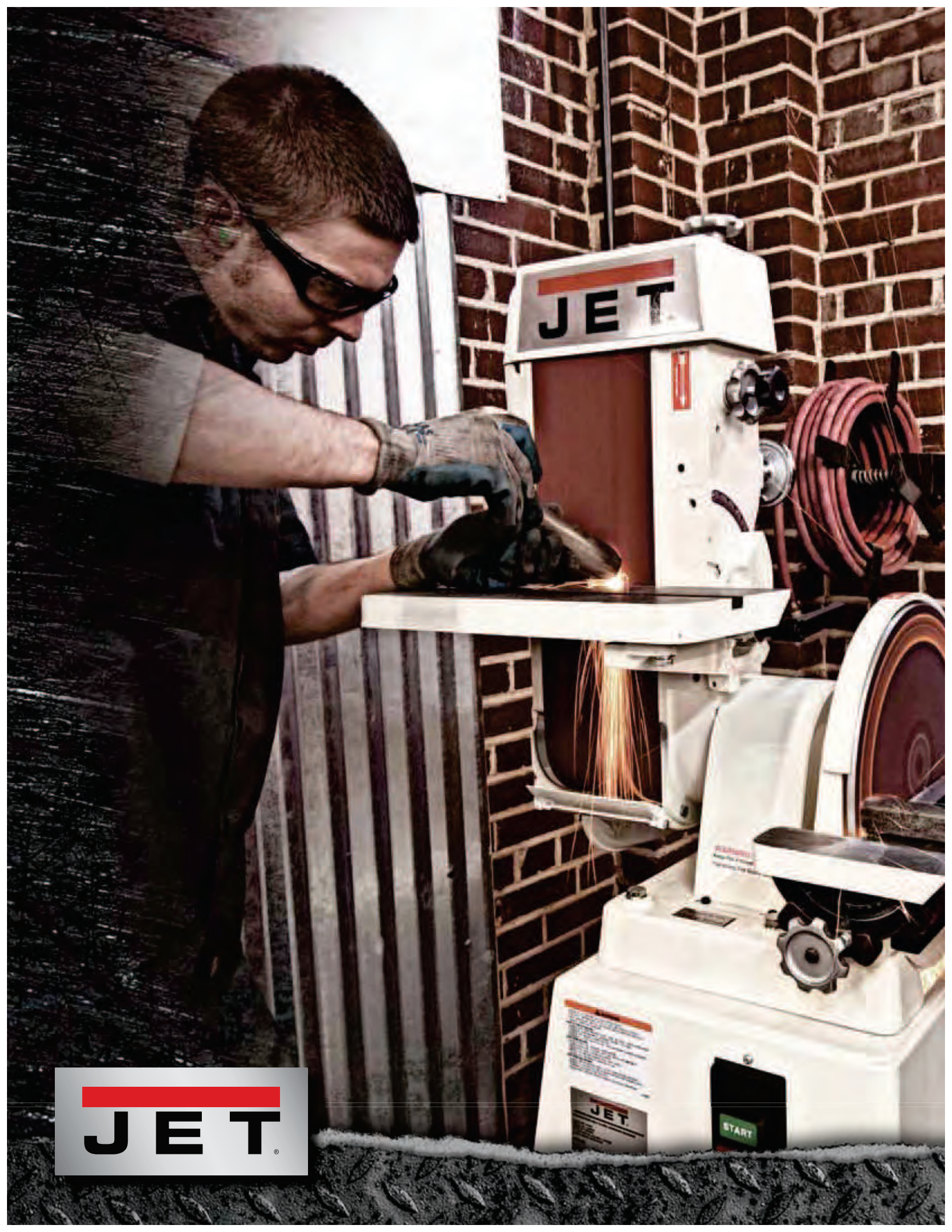

**JET**





# FINISHING

For a high-quality finish every time, experts rely on JET grinders, sanders and finishing machines. Because your complete satisfaction is our main objective, every JET Bench Grinder, Sander and Finishing machines are built to last and exceed your expectations. Professionally-written manuals enable more efficient use, and every JET machine is backed by our industry-leading TWO-year warranty.

**FOR A HIGH-  
QUALITY  
FINISH  
EVERY TIME**



# BENCH GRINDERS

Delivering work power and pristine finishes to shops where work space may be at a premium. Cast iron JET Bench Grinders are built to withstand the high-volume demands of even the busiest shops. Grind, sharpen, and smooth all on the same machine with equal precision and flawless results.



## INDUSTRIAL BENCH GRINDER

### FEATURES

- UL listed
- Totally enclosed pre-lubricated ball bearings
- Heavy-duty guarded toggle switch on 8" and 10"
- Rubber mounts prevent movement

### STANDARD EQUIPMENT

- Cast iron wheel guards and dust vents
- One-piece quick adjusting spark guards
- Large eye shields with quick adjustment
- Adjustable tool rests
- Fine and coarse vitrified grinding wheels included



STOCK NUMBER	577101	577102	577103
Model Number	JBG-6A	JBG-8A	JBG-10A
Shaft Diameter (in.)	1/2	5/8	1
Wheel Diameter (dia. x W/in.)	6 x 3/4	8 x 1	10 x 1
Wheel Speed (RPM)	3,450	3,450	1,725
Wheel Grits	36/60	36/60	24/46
Motor	1/2HP, 115V, 1Ph	1HP, 115V, 1Ph	1-1/2HP, 115V, 1Ph
Overall Dimensions (in./ L x W x H)	17 x 10 x 9	19 x 12 x 11	25 x 16 x 15
Net Weight (lbs.)	38	60	110



## PEDESTAL STAND FOR BENCH GRINDERS

### FEATURES

- Heavy-duty cast iron construction provides strength and durability
- Wide stance base gives you a stable grinder workstation
- Coolant tank and tool tray are on an adjustable platform for your convenience
- Compatible with all JET Bench Grinders

STOCK NUMBER	577172
Model Number	JPS-2A
Mounting Surface (in./ L x W)	11 x 10
Overall Dimensions (in./ L x W x H)	31 x 21 x 5
Net Weight (lbs.)	52





# 1" x 42" BENCH BELT AND DISC SANDER

## FEATURES

- Hinged idler wheel cover
- Deluxe miter gauge turns and locks for common angles 45° left and right
- Abrasive belt unit does the work of a jig-saw, coping saw or hand file while removing material and finishing at the same time, allows the operator to get into small openings plus handle odd shapes and angles
- Removable platen allows for sanding, grinding or finishing of outside curves or odd shaped work pieces on the belt

## STANDARD EQUIPMENT

- Deluxe miter gauge
- Cast iron tilting table
- Cast construction
- Heavy duty steel base and rubber feet
- Removable platen
- Adjustable dust deflector and dust chute

**2**  
YEAR WARRANTY

STOCK NUMBER	577003
Model Number	J-4002
Disc Speed (RPM)	1,725
Belt Size (in./W x L)	1 x 42
Belt Speed (SFPM)	3,000
Disc Table Size (in.)	4 x 10
Table Slots (in.)	5/8
Disc Table Tilt (deg.)	45 out
Motor	1/3HP, 115VAC, 1Ph
Overall Dimensions (in./ L x W x H)	21 x 22 x 14
Net Weight (lbs.)	62



# 2" x 42" BENCH BELT AND 8" DISC SANDER

## FEATURES

- Deluxe miter gauge that turns and locks for common angles, 45° both left and right
- Hinged idler wheel cover
- Abrasive belt unit does the work of a jig saw, coping saw or hand file while removing material and finishing at the same time, allows the operator to get into small openings, plus handle odd shapes and angles
- Allows for sanding, grinding or finishing of outside, curves or odd shaped work pieces on the belt

## STANDARD EQUIPMENT

- Deluxe miter gauge
- Cast iron tilting table
- Cast construction
- Heavy duty steel base and rubber feet
- Removable platen
- Dust deflector and chute

**2**  
YEAR WARRANTY

STOCK NUMBER	577004
Model Number	J-41002
Disc Speed (RPM)	3,450
Belt Size (in./W x L)	2 x 42
Belt Speed (SFPM)	3,100
Disc Table Size (in.)	10-3/4 x 7-1/2
Disc Table Tilt (deg.)	45
Motor	3/4HP, 115V, 1Ph
Overall Dimensions (in./L x W x H)	20-1/2 x 22-3/4 x 20
Net Weight (lbs.)	60



**FINISHING**



# BELT AND DISC SANDERS

High-speed precision that conforms to curves, variable speed operation for command and control at all times and confidence that JET Square Wheel Grinders, and combination Sanders and Chamfering Machines will perform at the flip of a switch.



## 6" x 48" BELT AND 10" DISC SANDER

### FEATURES

- 6" x 48" Belt
- 10" Disc
- Two cast iron tilting tables for mitering applications
- Full access to the belt when tilted in the horizontal position
- Dust collection shrouds on belt and disc
- Quick-release tension mechanism makes belt changes quick and easy
- Removable safety key switch
- Enclosed base protects motor from sanding dust

### STANDARD EQUIPMENT

- Miter gauge
- Heavy-duty one piece steel stand



STOCK NUMBER	414550K
Model Number	J-4210K
Disc Speed (RPM)	2,100
Belt Size (in./W x L)	6 x 48
Belt Speed (SFPM)	1,650
Disc Table Size (L x W/in.)	7-1/2 x 13
Table Slots (in.)	5/8
Disc Table Tilt (deg.)	45 out
Motor	1HP, 115V, 1Ph
Overall Dimensions (in./ L x W x H)	23 x 26 x 61
Net Weight (lbs.)	170

The JET logo, featuring the word 'JET' in a bold, black, sans-serif font with a red horizontal bar above it.



# INDUSTRIAL COMBINATION BELT AND DISC FINISHING MACHINE

**2**  
YEAR WARRANTY

## FEATURES

- Belt operates at any angle
- Powered by a heavy duty 1-1/2HP TEFC motor
- Contour finishing, mitering, flat finishing, beveling and precision finishing
- Plain and compound miters are easily obtained by using the standard die cast aluminum miter gauge
- Fully machined, balanced disc runs vibration free

## STANDARD EQUIPMENT

- Adjustable heavy duty cast iron removable platen
- Removable upper guard for contour finishing
- Variable position locks, belt head adjusts vertically, horizontally and in between
- Large cast iron slotted table
- Adjustable dust collector and dust chute
- Completely enclosed drums and a guarded sanding belt
- Heavy duty one piece steel stand



414551

**NEW!**



Contour Finishing, Mitering, Flat Finishing, Beveling and Precision Finishing

STOCK NUMBER	414551	414552	414553
Model Number	J-4200A	J-4200A-2	J-4202A
Disc Speed (RPM)	1,960	1,960	1,960
Belt Size (in./W x L)	6 x 48	6 x 48	6 x 48
Belt Speed (SFPM)	2,850	2,850	2,850
Disc Table Size (in./L x W)	12 x 16-3/8	12 x 16-3/8	12 x 16-3/8
Table Slots (in.)	3/8 x 3/4	3/8 x 3/4	3/8 x 3/4
Disc Table Tilt (deg.)	45° out and 20° in	45° out and 20° in	45° out and 20° in
Motor	1-1/2HP, 115V, 1Ph	1-1/2HP, 230V, 1Ph	1-1/2HP, 230V, 3Ph
Overall Dimensions (in./ L x W x H)	26 x 19 x 58	26 x 19 x 58	26 x 19 x 58
Net Weight (lbs.)	250	250	250

**FINISHING**



# 6" INDUSTRIAL BELT FINISHING MACHINE



## FEATURES

- Table tilts 45° out and 20° in for all angle finishing operations
- Adjustable dust deflector for and dust chute
- Completely enclosed drums and a guarded sanding belt
- Fine thread adjustment for simple and easy belt tracking
- Plain and compound miters are easily obtained by using the standard diecast aluminum miter gauge
- Will handle virtually all the finishing operations in a production line
- Adjustable heavy duty cast iron removable platen
- Removable upper guard for contour finishing
- Variable position locks, belt head adjusts vertically, horizontally and in between

## STANDARD EQUIPMENT

- Miter gauge
- Heavy duty one piece steel stand



414600

STOCK NUMBER	414600	414601
Model Number	J-4300A	J-4301A
Belt Size (in./ W x L)	6 x 48	6 x 48
Belt Speed (SFPM)	2,850	2,850
Belt Table Size (in.)	7-3/8 x 14-3/4	7-3/8 x 14-3/4
Belt Table Tilt (deg.)	45° out and 20° in	45° out and 20° in
Platen (in./L x W)	6-1/4 x 14-3/4	6-1/4 x 14-3/4
Motor	1-1/2HP, 115/230V, 1Ph, Prewired 115V	1-1/2HP, 230V, 3Ph
Overall Dimensions (in./ L x W x H)	26 x 19 x 58	26 x 19 x 58
Net Weight (lbs.)	215	215



# 2" x 72" SQUARE WHEEL BELT GRINDER

JET's multipurpose Square Wheel Grinder is the only finishing machine you'll ever need or want. This easy to operate versatile grinder provides fast, efficient grinding and finishing all in one machine

## FEATURES

- **Flat & Angular Stock:** Platen setting is the perfect angle for high speed, precision flat and level grinding
- **Shaping:** For grinding, and refinishing cylindrical shapes. Yoke surface conforms to shape of the surface to produce an even, smooth finish
- **Roughing:** Serrated contact wheel is used for removing heavy stock, cleaning up a weld or snagging a casting
- **Contouring:** Grind difficult to reach areas with the 3" x 2" or 1-1/2" x 2" diameter contact wheels



STOCK NUMBER	577000
Model Number	J-4103
Belt Size (in./ W x L)	2 x 72
Belt Speed (SFPM)	4,600
Contact Wheel Diameter (in.)	8 x 2; 3 x 2; 1-1/2 x 2
Contact Wheel Durometer	70
Motor	1HP, 115/230V, 1Ph, Prewired 115V
Overall Dimensions (in./ L x W x H)	17 x 31 x 17
Net Weight (lbs.)	163

# 2" x 72" VARI-SPEED SQUARE WHEEL GRINDER

## FEATURES

- Infinite variable speeds 1100 to 6,000 SFPM
- Latest AC Inverter variable speed technology
- Continuous speed adjustment while in operation
- Easy to view SFPM readout



STOCK NUMBER	577001
Model Number	J-4126AC
Belt Size (in./W x L)	2 x 72
Belt Speed (SFPM)	1,100 - 6,000
Contact Wheel Diameter (in.)	8
Contact Wheel Durometer	70
Motor	1HP, 115V, 1Ph, AC Inverter
Overall Dimensions (in./ L x W x H)	17 x 31 x 17
Net Weight (lbs.)	163

**FINISHING**



# 12" INDUSTRIAL DISC FINISHING MACHINE



## FEATURES

- Optimum speed of 1,960 RPM, which is ideal for both metal and wood finishing
- Fully machined, balanced disc runs vibration free
- Plain and compound miters are easily obtained by using the standard die-cast aluminum miter gauge
- Large cast iron slotted table
- Easy to read scale shows exact degree of table tilt

## STANDARD EQUIPMENT

- Miter gauge
- Heavy duty one piece steel stand

STOCK NUMBER	414602	414603
Model Number	J-4400A	J-4401A
Disc Diameter (in.)	12	12
Disc Speed (RPM)	1,960	1,960
Disc Table Size (in./ L x W)	12 x 16-3/8	12 x 16-3/8
Table Slots (in.)	3/8 x 3/4	3/8 x 3/4
Disc Table Tilt (deg.)	45° out and 20° in	45° out and 20° in
Motor	1-1/2HP, 115/230V, 1Ph, Prewired 115V	1-1/2HP, 230/460V, 3Ph, Prewired 230V
Overall Dimensions (in./ L x W x H)	16 x 19 x 43	16 x 19 x 43
Net Weight (lbs.)	175	175



414602

**JET**



# 20" DISC SANDER

## FEATURES

- Tilting table capability adds flexibility of 45° forward and 15° backward on positive lock rack and gear
- Extra large tilting table lowers completely below disc for use of the entire disc surface

## STANDARD EQUIPMENT

- Direct drive motor
- Low voltage protection switch
- Rigid column and heavy duty base
- Miter gauge
- Wrap-over guard for added safety



STOCK NUMBER	577010	577011
Model Number	J-4421-2	J-4421-4
Disc Diameter (in.)	20	20
Disc Speed (RPM)	1,725	1,725
Disc Table Size (in./ L x W)	27-1/2 x 10-1/2	27-1/2 x 10-1/2
Table Slots (in.)	3/8 x 3/4	3/8 x 3/4
Disc Table Tilt (deg.)	45° out, 15° in	45° out, 15° in
Motor	3HP, 220V, 3Ph	3HP, 460V, 3Ph
Overall Dimensions (in./ L x W x H)	30 x 28 x 53	30 x 28 x 53
Net Weight (lbs.)	400	400



577010

**FINISHING**



# BELT AND CHAMFERING MACHINE

## FEATURES

- Contour finishing, mitering, flat finishing just to name a few applications
- Will handle virtually all the finishing operations in a production line
- Removable upper guard for contour finishing
- Variable position locks, belt head adjusts vertically, horizontally and in between
- Large cast iron slotted table
- Adjustable dust deflector and dust chute
- Easily adjustable chamfering machine manages additional finishing jobs such as beveling, deburring on flats and squares of ferrous and non-ferrous materials
- Precision chamfer, bevel or deburr easily
- Chamfer angles from 15° to 45°
- Easily adjustable depth of cut
- The cutter head has 8 easy to change inserts and combined with an adjustable depth of cut and angle of cut capacity, can deliver accurate finishes on a repetitive basis

## STANDARD EQUIPMENT

- Miter gauge
- Heavy duty one piece stand
- 3 cutter head with replaceable inserts
- Cast iron V table



414604

STOCK NUMBER	414604	414605
Model Number	J-4500	J-4501
Belt Size (in./ W x L)	6 x 48	6 x 48
Belt Speed (SFPM)	2,850	2,850
Belt Table Size (in./ L x W)	7-3/8 x 14-3/4	7-3/8 x 14-3/4
Belt Table Tilt (deg.)	45° out and 20° in	45° out and 20° in
Platen (in.)	6-1/4 x 14-3/4	6-1/4 x 14-3/4
Minimum Length of Work Piece (in.)	3.5	3.5
Max. Cut at 45°	1/4	1/4
Max. Cut at 15°	3/16	3/16
Bevel Angle (deg.)	15 - 45	15 - 45
Motor	1-1/2HP, 115/230V, 1Ph, Prewired 115V	1-1/2 HP, 230V, 3Ph
Overall Dimensions (in./ L x W x H)	26 x 19 x 58	26 x 19 x 58
Net Weight (lbs.)	250	250

**JET**





# WARRANTY AND SERVICE

## WARRANTY AND SERVICE



Walter Meier (Manufacturing) Inc., warrants every product it sells. If one of our tools needs service or repair, one of our Authorized Service Centers located throughout the United States can give you quick service. In most cases, any of these Walter Meier Authorized Service Centers can authorize warranty repair, assist you in obtaining parts, or perform routine maintenance and major repair on your JET tools. For the name of an Authorized Service Center in your area call **1-800-274-6848**.

## MORE INFORMATION

Walter Meier is consistently adding new products to the line. For complete, up-to-date product information, check with your local Walter Meier distributor, or visit [jettools.com](http://jettools.com)

## WARRANTY

JET products carry a limited warranty which varies in duration based upon the product.

 <ul style="list-style-type: none"><li>• Metalforming</li><li>• Mill/Drills</li><li>• Milling Machines</li><li>• MW Bandsaws</li><li>• MW Drill Presses</li><li>• MW Finishing Equipment</li><li>• MW Lathes</li></ul>	 <ul style="list-style-type: none"><li>• Lathe Accessories</li><li>• Machine Accessories</li></ul>
---	---

## WHAT IS COVERED?

This warranty covers any defects in workmanship or materials subject to the exceptions stated below. Cutting tools, abrasives and other consumables are excluded from warranty coverage.

## WHO IS COVERED?

This warranty covers only the initial purchaser of the product.

## WHAT IS THE PERIOD OF COVERAGE?

The general JET warranty lasts for the time period specified in the product literature of each product.

## HOW TO GET SERVICE

The product or part must be returned for examination, postage prepaid, to a location designated by us. For the name of the location nearest you, please call **1-800-274-6848**.

You must provide proof of initial purchase date and an explanation of the complaint must accompany the merchandise. If our inspection discloses a defect, we will repair or replace the product, or refund the purchase price, at our option.

We will return the repaired product or replacement at our expense unless it is determined by us that there is no defect, or that the defect resulted from causes not within the scope of our warranty in which case we will, at your direction, dispose of or return the product. In the event you choose to have the product returned, you will be responsible for the shipping and handling costs of the return.

## HOW STATE LAW APPLIES

This warranty gives you specific legal rights; you may also have other rights which vary from state to state.

## LIMITATIONS ON THIS WARRANTY

WALTER MEIER LIMITS ALL IMPLIED WARRANTIES TO THE PERIOD OF THE LIMITED WARRANTY FOR EACH PRODUCT. EXCEPT AS STATED HEREIN, ANY IMPLIED WARRANTIES OR MERCHANTABILITY AND FITNESS ARE EXCLUDED. SOME STATES DO NOT ALLOW LIMITATIONS ON HOW LONG THE IMPLIED WARRANTY LASTS, SO THE ABOVE LIMITATION MAY NOT APPLY TO YOU. WALTER MEIER SHALL IN NO EVENT BE LIABLE FOR DEATH, INJURIES TO PERSONS OR PROPERTY, OR FOR INCIDENTAL, CONTINGENT, SPECIAL, OR CONSEQUENTIAL DAMAGES ARISING FROM THE USE OF OUR PRODUCTS. SOME STATES DO NOT ALLOW THE EXCLUSION OR LIMITATION OF INCIDENTAL OR CONSEQUENTIAL DAMAGES, SO THE ABOVE LIMITATION OR EXCLUSION MAY NOT APPLY TO YOU.

Walter Meier sells through distributors only. The specifications in Walter Meier catalogs are given as general information and are not binding. Members of Walter Meier reserve the right to effect at any time, without prior notice, those alterations to parts, fittings, and accessory equipment which they may deem necessary for any reason whatsoever. JET® branded products are not sold in Canada by Walter Meier.





Stock No. 904219  
75K 6-2010  
©2010 Walter Meier (Manufacturing) Inc. :: Printed in the U.S.A.

Walter Meier (Manufacturing) Inc.  
Lavergne, TN 37086 U.S.A.  
[waltermeier.com](http://waltermeier.com)