

# JET



# TURNING

EMPOWERING SHOP PERFORMANCE

JETTOOLS.COM





# TURNING

JET's extensive selection of turning machines allows the experts to choose the lathes they need to perform any turning operation.

Precision manufactured to meet the demands of even the highest volume shop, JET turning machines, taper attachments, collet closers, digital readouts and accessories are built to last. JET machines are backed by an industry-best Two year warranty, and come with superior customer support like professional manuals to ensure precise, accurate and efficient operation.

## CONTENTS >

<b>TURNING OVERVIEW</b> .....	<b>004-007</b>
<b>HOBBY LATHE</b> .....	<b>008</b>
<b>BELT DRIVE LATHES</b> .....	<b>009-011</b>
<b>GEARED HEAD LATHES</b> .....	<b>012-15</b>
<b>LARGE SPINDLE BORE LATHES</b> ....	<b>013-021</b>
<b>CNC LATHE</b> .....	<b>022-023</b>
<b>ACCESSORIES</b> .....	<b>024-025</b>
<b>DIGITAL READ OUTS</b> .....	<b>026-029</b>
<b>WARRANTY</b> .....	<b>031</b>





# THE JET ADVANTAGE



## DEPTH AND BREADTH OF LINE



- JET offers a range of manual Belt Drive & Geared Head Bench Lathes, Engine Lathes, and Large Spindle Bore Lathes and is now introducing our CL-1640ZX-CNC Lathe.
- JET will customize your lathe for you, we will install DRO's, Collet Closer and Taper Attachments or combinations so your JET lathe is ready for use when it hits your shop floor.

## QUALITY



JET lathes are built and tested in our factories to deliver consistent quality and tolerances.

## INNOVATIVE PRODUCTS



- JET is committed to ongoing innovation demonstrated in the NEW CNC Lathe. Take a minute to review all the features available on page 22-23.
- JET's ZX Lathes have many innovated features such as the casted one piece cast iron base to absorb vibrations during heavier cuts, Universal gear box that allows threading with no gear change and the chip tray is in the front which allows the machine to be placed against the wall where space is an issue, just to name a few!

## PROFESSIONAL MANUALS



JET manuals are professionally written by engineers for ease of use. All manuals come complete with parts breakdown and electrical drawings.



## INDUSTRY LEADING WARRANTY

JET offers a 2 Year Warranty; the longest warranty in the industry, confirming our confidence in the quality of our design and workmanship. See page 31.



## SERVICE CENTERS

JET offers authorized service centers across the USA. You can be assured a qualified local technician can troubleshoot, order parts and repair your equipment should a problem arise.



# TURNING OVERVIEW

**JET STRIVES TO MAKE YOUR JOB EASIER, BY PROVIDING YOU WITH SOME BASIC AND HELPFUL INFORMATION ON ALL OF OUR TURNING PRODUCTS.**

## WHAT IS A LATHE?

A lathe is a machine tool which spins material to perform various operations such as cutting, sanding, knurling, drilling, or deformation with tools that are applied to the work piece to create an object which has symmetry about an axis of rotation.

Lathes are used in metalworking, metal spinning, and glass working. Most suitably equipped metalworking lathes are used to produce most solids of revolution, plane surfaces and screw threads or helices. The material is held in place by either one or two centers, at least one of which can be moved horizontally to accommodate varying material lengths. Lathes may be manually operated, mechanically automated, or digitally automated via CNC.

The basic lathe that was designed to cut cylindrical metal stock has been developed further to produce screw threads, tapered work, drilled holes, knurled surfaces and crankshafts. Lathes offer a variety of rotating speeds and a means to manually and automatically move the cutting tool into the workpiece. Machinists and maintenance shop personnel must be thoroughly familiar with the lathe and its operations to accomplish the repair and fabrication of needed parts.

## ENGINE LATHES

The size of an engine lathe is determined by the largest piece of stock that can be machined. Before machining a workpiece, the following measurements must be considered: the diameter of the work that will swing over the bed and the length between lathe centers.

Engine lathes all have the same general functional parts, the bed is the foundation of the working parts of the lathe. The main feature of its construction are the ways which are formed on its upper surface and run the full length of the bed. Ways provide the means for holding the tailstock and carriage, which slide along the ways, in alignment with the permanently attached headstock.

The headstock is located on the operator's left end of the lathe bed. It contains the main spindle and oil reservoir and the gearing mechanism for obtaining various spindle speeds and for transmitting power to the feeding and threading mechanism. The headstock is driven by an electric motor connected either to a belt, pulley or geared system. The headstock is mounted on the bearings and is hardened and ground to fit different lathe holding devices. The spindle has a hole through its entire length to accommodate long workpieces. The hole in the nose of the spindle usually has a standard Morse taper which varies with the size of the chuck. Centers, collets, drill chucks, tapered shanked drills and reamers may be inserted into the spindle. Chucks, drive plates and face plates may be screwed into the spindle or clamped onto the spindle nose.

The tailstock is located on the opposite end of the lathe from the headstock. It supports one end of the workpiece when machining between centers, supports long pieces held in the chuck, and holds various forms of cutting tools such as drills, reamers and taps. The tailstock is mounted on the ways and is designed to be clamped at any point. It has a sliding spindle that is operated by a hand wheel. The tailstock may be adjusted laterally anywhere along the ways.

The carriage includes the apron, saddle, compound rest, cross slide, tool post and the cutting tool. It sits across the ways and in front of the bed. The function of the carriage is to carry and move the cutting tool. It can be moved by hand or power and can be clamped into position with a locking nut. The saddle carries the cross slide and the compound rest. The cross slide is mounted on the ways on top of the saddle and is moved back and forth at 90 degrees to the axis of the lathe by the cross slide lead screw. The lead screw can be hand or power activated. A feed reversing lever, located on the carriage or headstock, can be used to cause the carriage and the cross slide to reverse the direction of travel. The compound rest is mounted on the cross slide and can swiveled and clamped at any angle in a horizontal plane. The cutting tool and tool holder are secured in the tool post which is mounted directly to the compound rest. The apron contains the gears and feed clutches which transmits motion and feed rod or lead screw to the carriage and cross slide.

The logo for JET, featuring the letters 'J E T' in a bold, black, sans-serif font. Above the letters is a thick red horizontal bar. A small registered trademark symbol (®) is located to the right of the letter 'T'. The logo is set against a light gray rectangular background.



## COMMON TERMINOLOGY OF A MANUAL LATHE

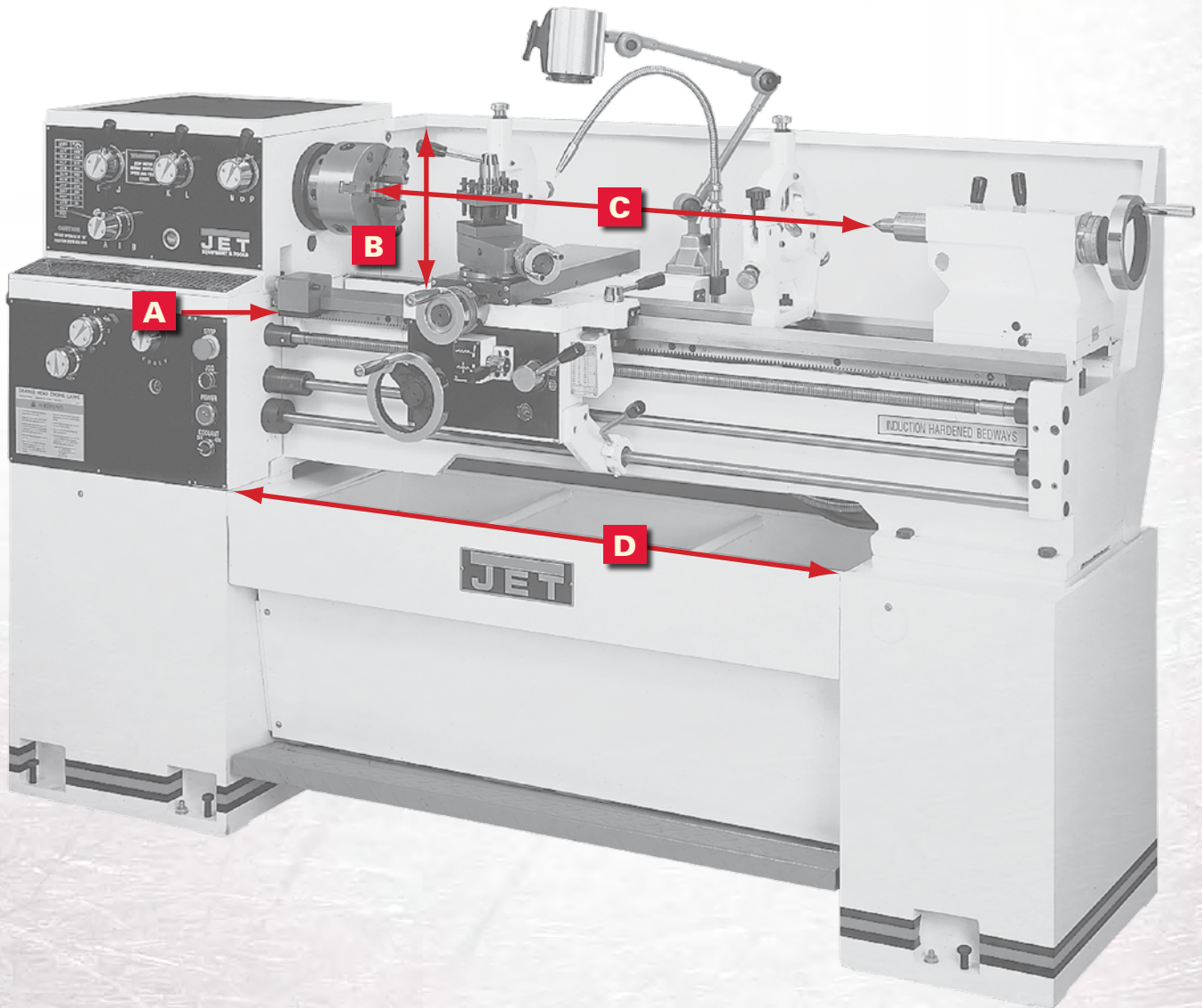

**A** Gap: The gap allows you to turn a larger diameter work piece.

**B** Swing ( ex: 14")

**C** Distance between centers is from chuck to tailstock

**D** Length of Bed

# TURNING



# TURNING OVERVIEW



- |                    |                          |                         |
|--------------------|--------------------------|-------------------------|
| <b>A</b> Headstock | <b>E</b> Compound Rest   | <b>I</b> Threading Dial |
| <b>B</b> Gearbox   | <b>F</b> Toolpost        | <b>J</b> Steadyrest     |
| <b>C</b> Spindle   | <b>G</b> Powerfeed Lever | <b>K</b> Leadscrew      |
| <b>D</b> Chuck     | <b>H</b> Carriage        | <b>L</b> Tailstock      |







**FREE** 4 HOURS OF  
IN-HOUSE TRAINING  
CNC TRAINING FROM ANILAM

## **JET LATHES ARE PRECISION-BUILT AND DESIGNED TO LAST.**

We have a full range of Bench and Engine Lathes in Belt Drive, Variable Speed and CNC models. We can install DRO's, collet closers and taper attachments to meet your turning needs.

JET offers an Industry leading 4-hour in-house training from Anilam for any of our CNC Lathes. We also carry many accessories to get your Lathe up and running when it hits your shop floor.

### **LATHES AVAILABLE ARE:**

- Belt Drive Bench Lathes
- Gear Head Bench Lathes
- Gear Head Engine Models
- Large Spindle Bore Engine Lathe
- CNC Lathe

### **PACKAGES/ACCESSORIES AVAILABLE ARE:**

- Digital Readouts (DRO)
- Taper attachments
- Collet closers
- Quick change tool post sets
- 5C Collet Sets
- Tooling Kits
- Coolant Systems

# TURNING



# JET JHL-610 HOBBY LATHE

## FEATURES

- Electronic Variable Speed 100-2000RPM
- Over-load protection
- Tailstock has an MT-1 and is made from cast-iron
- Leadscrew is protected under the bed with auto-feed mechanism
- Cross-slide has an industrial-style bolt-down heavy cast-iron tool holder with calibrated feed
- Capable of cutting metric thread 0.5-1.25mm pitch
- Capable of cutting inch thread 16-24 TPI

## STANDARD EQUIPMENT

- 3-jaw chuck
- Dead center MT1
- Wrench Set
- Oil Can
- Splash Guard
- Chuck guard with automatic on/off switch for safety
- Gear change kit

STOCK NUMBER	321200
Model Number	JHL-610
Swing over Bed (in.)	5-1/2
Distance Between Centers (in.)	9-3/4
Spindle Bore (in.)	3/8
Spindle Mount	MT-2
Number of Spindle Speeds	Electronic Variable Speed
Range of Spindle Speeds (RPM)	100 - 2,000
Number of Inch Threads	5
Range of Inch Threads (TPI)	16 - 24
Number of Metric Threads	5
Range of Metric Threads	0.5 - 1.25
Max Tool Size (in.)	3/8-shank
Cross Slide Travel (in.)	2-1/2
Carriage Travel (in.)	7-1/16
Taper in Tailstock Spindle	MT-1
Overall Dimensions (in./ L x W x H)	27 x 14 x 13
Motor	150W, 115V, Single Phase
Net Weight (lbs.)	50

OPTIONAL EQUIPMENT	STOCK NUMBER
Stand	350213
11 pc. cutter set	321201
Quick Change cutter rest	321202
Quick Vise	321203
4 Jaw Chuck	321204
Wood tool rest/center	321205
Tool Holder	321206
Clamping Kit for face plate	321207
Lathe Dog	321208
Live Center	321209
Ball Head cutting set	321210
Steady rest	321211
Follow rest	321212



Shown with  
Optional Stand



# BELT DRIVE LATHES

The industry standard in Metal Turning, JET Belt Drive Bench Lathes come fully loaded and designed to accommodate a huge variety of optional accessories to perform a variety of operations, while increasing overall production. A JET Belt Drive Bench Lathe allows the operator to change between standard and metric gears quickly and easily to enhance productivity and efficiency, and create finely-shaped tapering with great precision.

## 9" x 20" BELT DRIVE BENCH LATHE

### FEATURES

- Spindle supported by precision tapered roller bearings
- Hardened and ground bedways
- Reversing switch included for added versatility
- Backlash adjustments provided throughout the carriage
- Quick change gearbox provides wide range of inch and metric threads
- Power Longitudinal feed allows threading and reverse threading
- Standard 1-1/2 x 8 TPI spindle mount allows for many aftermarket accessories
- Tailstock is adjustable for taper cuts

### STANDARD EQUIPMENT

- 4" 3-jaw chuck with threaded back plate
- 7" 4-jaw chuck with threaded back plate
- Metric Change gears
- Enclosed gear box
- Centers
- Threading dial



Shown with  
Optional Stand



STOCK NUMBER	321376
Model Number	BD-920W
Swing over Bed (in.)	9
Swing over Cross Slide (in.)	5-5/16
Distance Between Centers (in.)	20
Spindle Bore (in.)	7/8
Spindle Mount (TPI)	1/2 x 8
Spindle Taper w/ Sleeve	MT-3
Number of Spindle Speeds	6
Range of Spindle Speeds (RPM)	130 - 2,000
Number of Longitudinal Feed Rates	60
Range of Longitudinal Feeds (IPR)	.0006 - .037
Number of Inch Threads	30
Range of Inch Threads (TPI)	8 - 60
Number of Metric Threads	18
Range of Metric Threads	0.4 - 3.5
Max Tool Size (in.)	1/2 x 1/2
Compound Slide Travel (in.)	1-7/8
Cross Slide Travel (in.)	4-3/8
Carriage Travel (in.)	16
Tailstock Spindle Travel (in.)	1-9/16
Taper in Tailstock Spindle	MT-2
Steady Rest Capacity (in.)	1/4 - 1-7/8
Follow Rest Capacity (in.)	1/4 - 1-1/8
Width of Bed (in.)	4-1/2
Overall Dimensions (in./ L x W x H)	37 x 18-3/4 x 17-3/8
Motor	3/4HP, 1Ph, 115V Only
Net Weight (lbs.)	265

OPTIONAL EQUIPMENT	STOCK NUMBER
S-920N Stand for BD-920N	321374
Lathe with S-920N Stand	321155K





# 13" x 40" BELT DRIVE BENCH LATHE

## FEATURES

- Enclosed gearbox design provides smooth, quiet operation
- Fast, easy speed changes
- Helical cut headstock gears reduce noise
- V-way bed is induction hardened and ground
- Gap bed section provided for large diameter work
- Low voltage motor controls
- Changes gears allow metric threading
- Spindle is supported by precision tapered roller bearings
- Independent leadscrew and feed rod
- T-slotted compound slide with four-way tool post
- Carriage mounted spindle control lever
- Automatic feeding and threading are fully interlocked
- Tailstock may be offset for turning tapers and includes an inch/metric graduated quill

## STANDARD EQUIPMENT

- Coolant tray
- Tolerance test certificate
- 6" 3-jaw direct mount scroll chuck with top reversing jaws
- 8" 4-jaw independent chuck
- 12" faceplate
- Four-way tool post
- Steady and follow rest
- Metric change gear
- Centers with headstock center sleeve
- Threading dial
- Micro Carriage Bed Stop
- Tool box with tools



Shown with Optional Stand



**J E T**





STOCK NUMBER	321360A
Model Number	BDB-1340A
Swing over Bed (in.)	13
Swing over Cross Slide (in.)	7-25/32
Swing Through Gap (in.)	18-3/4
Length of Gap (in.)	8
Distance Between Centers (in.)	40
Spindle Bore (in.)	1-3/8
Spindle Mount	D1-4
Spindle Taper (w/ Sleeve)	MT-5 (MT-3)
Number of Spindle Speeds	12
Range of Spindle Speeds (RPM)	60 - 1,240
Number of Longitudinal and Cross Feed Rates	40
Range of Longitudinal Feeds (IPR)	.0018 - .0374
Range of Cross Feeds (IPR)	.0012 - .0345
Number of Inch Threads	40
Range of Inch Threads (TPI)	4-112
Number of Metric Threads	27
Range of Metric Threads	0.2-6
Max Tool Size (in.)	5/8 x 5/8
Compound Slide Travel (in.)	2-11/16
Cross Slide Travel (in.)	6-5/16
Carriage Travel (in.)	35
Tailstock Spindle Travel (in.)	3-3/4
Taper in Tailstock Spindle	MT-3
Steady Rest Capacity (in.)	2-5/8
Follow Rest Capacity (in.)	2-3/4
Width of Bed (in.)	7-3/8
Overall Dimensions (in./ L x W x H)	71 x 32 x 45 with Stand
Motor	2HP, 1Ph, 230V
Net Weight (lbs.)	1,175

#### BDB-1340A LATHE AND ACCESSORY PACKAGES INSTALLED

BDB-1340A with Acu-Rite VUE 2 Axis DRO	321110
BDB-1340A with Collet Closer	321111
BDB-1340A with Taper Attachment & Collet Closer	321112
BDB-1340A with Acu-Rite 200S 2 Axis DRO	321121
BDB-1340A with Newall DP700 2-Axis DRO	321130

**CALL FOR ADDITIONAL PACKAGES**



# GEARED HEAD LATHES

Yet another advancement in the field of Metal Turning led by JET. Designed for smooth, quiet operation and user versatility a JET Geared Head Bench Lathe cuts and tapers with exacting accuracy. JET Geared Head Bench Lathes feature extensive standard equipment packages that add to the ease of operation and production flexibility.



## 13" x 40" GEARED HEAD BENCH LATHE

### FEATURES

- Enclosed gearbox design provides smooth, quiet operation
- Hardened and ground gears are featured in the headstock and gearbox
- V-way bed is induction hardened and ground
- Gap bed section provided for large diameter work
- Adjustable gibs are incorporated in the carriage and slideways
- Fast, easy speed changes
- D1-4 spindle is precision ground for accuracy and supported by high quality tapered roller bearings
- Headstock is constantly oiled during operation
- Gear box gives wide inch threading and feed capabilities with no gear changes
- Independent leadscrew and feed rod
- Spindle actuation control is apron mounted
- Compound and cross slide have backlash adjustment
- Tailstock may be offset for turning tapers and includes an inch/metric graduated quill

### STANDARD EQUIPMENT

- Coolant tray
- Tolerance test certificate
- 6" 3-jaw direct mount scroll chuck with top reversing jaws
- 8" 4-jaw independent chuck
- 12" faceplate
- Four-way tool post
- Steady and follow rest
- Metric change gear
- Centers with headstock center sleeve
- Threading dial
- Tool box with tools
- Splash guard
- Micro Carriage Bed Stop



321357A - Shown with Optional Stand





**Enclosed Gearbox**



**Complete with 4-Way Tool Post and 3-Jaw Chuck Mounted for Ease of Use**



STOCK NUMBER	321357A	321359A
Model Number	GHB-1340A	GHB-1440A
Swing over Bed (in.)	13	14
Swing over Cross Slide (in.)	7-25/32	9-1/16
Swing Through Gap (in.)	18-3/4	20
Length of Gap (in.)	8	8
Distance Between Centers (in.)	43	43
Spindle Bore (in.)	1-3/8	1-3/8
Spindle Mount	D1-4	D1-4
Spindle Taper (w/ Sleeve)	MT-5 (MT-3)	MT-5 (MT-3)
Number of Spindle Speeds	8	8
Range of Spindle Speeds (RPM)	70 - 2,000	70 - 2,000
Number of Longitudinal and Cross Feed Rates	40	40
Range of Longitudinal Feeds (IPR)	0.0018 - 0.0374	0.0018 - 0.0374
Range of Cross Feeds (IPR)	0.0006 - 0.0130	0.0006 - 0.0130
Number of Inch Threads	38	38
Range of Inch Threads (TPI)	3-1/2 - 80	3-1/2 - 80
Number of Metric Threads	23	23
Range of Metric Threads	0.45 - 10	0.45 - 10
Max Tool Size (in.)	5/8 x 5/8	5/8 x 5/8
Compound Slide Travel (in.)	2-11/16	2-11/16
Cross Slide Travel (in.)	6-5/16	6-5/16
Carriage Travel (in.)	35	35
Tailstock Spindle Travel (in.)	3-3/4	3-3/4
Taper in Tailstock Spindle	MT-3	MT-3
Steady Rest Capacity (in.)	2-3/4	2-3/4
Follow Rest Capacity (in.)	2-3/8	2-3/8
Width of Bed (in.)	7-3/8	7-3/8
Overall Dimensions (in./ L x W x H)	79 x 28-1/2 x 30	79 x 28-1/2 x 30
Motor	2HP, 1Ph, 230V	2HP, 1Ph, 230V
Net Weight (lbs.)	1,154	1,211

**GHB-1340A LATHE AND ACCESSORY PACKAGES INSTALLED**

GHB-1340A with Acu-Rite VUE 2 Axis DRO & Collet Closer	321102
GHB-1340A with Taper Attachment	321119
GHB-1340A with Acu-Rite VUE 2 Axis DRO	321103
GHB-1340A with Taper Attachment & Collet Closer	321129
GHB-1340A with Newall DP700 2-Axis DRO, Collet Closer & Taper Attachment	321104
GHB-1340A with Newall DP700 2-Axis DRO & Taper Attachment	321115
GHB-1340A with Acu-Rite 200S 2 Axis DRO	321122
GHB-1340A with Acu-Rite 200S 2 Axis DRO & Taper Attachment	321123
GHB-1340A with Collet Closer	321124
GHB-1340A with Acu-Rite 200S 2 Axis DRO & Collet Closer	321125
GHB-1340A with Newall DP700 2-Axis DRO	321131
GHB-1340A with Acu-Rite VUE 2 Axis DRO, Taper Attachment & Collet Closer	321226
GHB-1340A with Newall DP700 2-Axis DRO & Collet Closer	321581

**GHB-1440A LATHE AND ACCESSORY PACKAGES INSTALLED**

GHB-1440A with Acu-Rite VUE 2 Axis DRO & Collet Closer	321107
GHB-1440A with Taper Attachment	321157
GHB-1440A with Acu-Rite VUE 2 Axis DRO	321158
GHB-1440A with Taper Attachment & Collet Closer	321159

**CALL FOR ADDITIONAL PACKAGES**





# 13" x 40" AND 14" x 40" GEARED HEAD ENGINE LATHES

## FEATURES

- Uniquely designed exclusively by JET
- Hardened and ground gears are featured in the headstock and gearbox
- D1-4 spindle is precision ground for accuracy and supported by high-quality tapered roller bearings
- Splined, not keyed, shafts are utilized in the headstock
- Spindle actuation control is apron mounted
- Headstock is constantly oiled during operation
- V-way bed design is induction hardened and ground
- Gap bed section provided for larger diameter work
- Independent leadscrew and feed rod
- Inch-metric dials are standard
- Compound and cross slide have backlash adjustment
- Adjustable gibs are incorporated in the carriage and slideways
- Tailstock may be offset for turning tapers and includes an inch-metric graduated quill
- Tolerance test certificate included

## STANDARD EQUIPMENT

- Micro-carriage bed stop
- Front removable chip tray
- Heavy-duty Stand
- 6" 3-jaw direct mount scroll chuck with top reversing jaws
- 8" 4-jaw independent chuck
- 12" face plate
- Four-way tool post
- Steady and follow rest
- Spindle jog button
- Foot brake
- Coolant system with splash guard
- Metric change gears
- Halogen work lamp

STOCK NUMBER	321810/321820	321830/321840
Model Number	GH-1340W-1 GH-1340W-3	GH-1440W-1 GH-1440W-3
Swing over Bed (in.)	13	14
Swing over Cross Slide (in.)	7-1/4	8-1/4
Swing Through Gap (in.)	19	20
Length of Gap (in.)	9-3/8	9-3/8
Distance Between Centers (in.)	40	40
Spindle Bore (in.)	1-1/2	1-1/2
Spindle Mount	D1-4	D1-4
Spindle Taper (w/ Sleeve)	MT-5 (MT-3)	MT-5 (MT-3)
Number of Spindle Speeds	12	12
Range of Spindle Speeds (RPM)	40 - 1,800	40 - 1,800
Number of Longitudinal and Cross Feed Rates	40	40
Range of Longitudinal Feeds (IPR)	0.0011 - 0.0271	0.0011 - 0.0271
Range of Cross Feeds (IPR)	0.0003 - 0.0103	0.0003 - 0.0103
Number of Inch Threads	40	40
Range of Inch Threads (TPI)	4 - 112	4 - 112
Number of Metric Threads	22	22
Range of Metric Threads	0.45 - 7.5	0.45 - 7.5
Max Tool Size (in.)	5/8 x 5/8	5/8 x 5/8
Compound Slide Travel (in.)	3-1/2	3-1/2
Cross Slide Travel (in.)	6-3/8	6-3/8
Carriage Travel (in.)	37-1/2	37-1/2
Tailstock Spindle Travel (in.)	4-3/4	4-3/4
Taper in Tailstock Spindle	MT-3	MT-3
Steady Rest Capacity (in.)	3-1/2	3-1/2
Follow Rest Capacity (in.)	2-3/4	2-3/4
Width of Bed (in.)	10-1/4	10-1/4
Overall Dimensions (in./ L x W x H)	78 x 38 x 59	78 x 38 x 59
Motor: Stock Number 321810/321830	3HP, 1Ph, 230V	3HP, 1Ph, 230V
Motor: Stock Number 321820/321840	3HP, 3Ph, 230/460V Prewired 230V	3HP, 3Ph, 230V/460V Prewired 230V
Net Weight (lbs.)	2,081	2,191



321810



**J E T**



### GHB-1340W-1 LATHE AND ACCESSORY PACKAGES INSTALLED

GH-1340W-1 with Taper Attachment	321521
GH-1340W-1 with Collet Closer	321151
GH-1340W-1 with Taper Attachment & Collet Closer	321160
GH-1340W-1 with Acu-Rite VUE 2 Axis DRO	321401
GH-1340W-1 with Acu-Rite VUE 2 Axis DRO & Taper Attachment	321425
GH-1340W-1 with Acu-Rite VUE 2 Axis DRO & Collet Closer	321146
GH-1340W-1 with Acu-Rite 200S 2 Axis DRO	321532
GH-1340W-1 with Acu-Rite 200S 2 Axis DRO & Taper Attachment	321128
GH-1340W-1 with Acu-Rite 200S 2 Axis DRO & Collet Closer	321526
GH-1340W-1 with Acu-Rite 200S 2 Axis DRO, Taper Attachment & Collet Closer	321538
GH-1340W-1 with Newall DP700 2-Axis DRO	321132
GH-1340W-1 with Newall DP700 2-Axis DRO & Taper Attachment	321154
GH-1340W-1 with Newall DP700 2-Axis DRO & Collet Closer	321142
GH-1340W-1 with Anilam 411 DRO	322401
GH-1340W-1 with Anilam 411 DRO Taper Attachment & Collet Closer	321126

### GHB-1340W-3 LATHE AND ACCESSORY PACKAGES INSTALLED

GH-1340W-3 with Taper Attachment	321516
GH-1340W-3 with Collet Closer	321555
GH-1340W-3 with Taper Attachment & Collet Closer	321577
GH-1340W-3 with Acu-Rite VUE 2 Axis DRO	321402
GH-1340W-3 with Acu-Rite VUE 2 Axis DRO & Taper Attachment	321172
GH-1340W-3 with Acu-Rite VUE 2 Axis DRO & Collet Closer	321170
GH-1340W-3 with Acu-Rite 200S 2 Axis DRO	321459
GH-1340W-3 with Acu-Rite 200S 2 Axis DRO & Taper Attachment	321447
GH-1340W-3 with Acu-Rite 200S 2 Axis DRO & Collet Closer	321562
GH-1340W-3 with Acu-Rite 200S 2 Axis DRO, Taper Attachment & Collet Closer	321546
GH-1340W-3 with Newall DP700 2-Axis DRO	321133
GH-1340W-3 with Newall DP700 2-Axis DRO & Taper Attachment	321143
GH-1340W-3 with Newall DP700 2-Axis DRO & Collet Closer	321537
GH-1340W-3 with Newall DP700 2-Axis DRO, Collet Closer & Taper Attachment	321547

### OPTIONAL EQUIPMENT

### STOCK NUMBER

5C Collet Set (16 pc.)

650014

### GHB-1440W-1 LATHE AND ACCESSORY PACKAGES INSTALLED

GH-1440W-1 with Taper Attachment	321517
GH-1440W-1 with Collet Closer	321518
GH-1440W-1 with Taper Attachment & Collet Closer	321500
GH-1440W-1 with Acu-Rite VUE 2 Axis DRO	321403
GH-1440W-1 with Acu-Rite VUE 2 Axis DRO & Taper Attachment	321175
GH-1440W-1 with Acu-Rite VUE 2 Axis DRO & Collet Closer	321173
GH-1440W-1 with Acu-Rite 200S 2 Axis DRO	321549
GH-1440W-1 with Acu-Rite 200S 2 Axis DRO & Taper Attachment	321550
GH-1440W-1 with Acu-Rite 200S 2 Axis DRO & Collet Closer	321548
GH-1440W-1 with Acu-Rite 200S 2 Axis DRO, Taper Attachment & Collet Closer	321564
GH-1440W-1 with Newall DP700 2-Axis DRO	321134
GH-1440W-1 with Newall DP700 2-Axis DRO & Taper Attachment	321145
GH-1440W-1 with Newall DP700 2-Axis DRO & Collet Closer	321558

### GHB-1440W-3 LATHE AND ACCESSORY PACKAGES INSTALLED

GH-1440W-3 with Taper Attachment	321522
GH-1440W-3 with Collet Closer	321729
GH-1440W-3 with Acu-Rite VUE 2 Axis DRO	321404
GH-1440W-3 with Acu-Rite VUE 2 Axis DRO & Taper Attachment	321176
GH-1440W-3 with Acu-Rite VUE 2 Axis DRO & Collet Closer	321406
GH-1440W-3 with Acu-Rite 200S 2 Axis DRO	321533
GH-1440W-3 with Acu-Rite 200S 2 Axis DRO & Taper Attachment	321563
GH-1440W-3 with Acu-Rite 200S 2 Axis DRO & Collet Closer	321524
GH-1440W-3 with Acu-Rite 200S 2 Axis DRO, Taper Attachment & Collet Closer	321572
GH-1440W-3 with Newall DP700 2-Axis DRO	321135
GH-1440W-3 with Newall DP700 2-Axis DRO & Taper Attachment	321144
GH-1440W-3 with Newall DP700 2-Axis DRO & Collet Closer	320536

### CALL FOR ADDITIONAL PACKAGES



Newall DP700 - DRO



Acu-Rite 200S - DRO





# LARGE SPINDLE BORE LATHES

A JET-exclusive design, the Large Spindle Bore Lathes provide power, precision, efficiency and reliability to your metal shop. A one-piece, cast iron base absorbs vibrations during operation to allow heavier cuts and ensure accuracy throughout, and the Universal Gearbox eliminates the need for change gears. A loaded standard equipment package makes JET Large Spindle Bore Lathes the model of production proficiency.



## 14" ZX SERIES LARGE SPINDLE BORE LATHES

### FEATURES

- Uniquely designed exclusively by JET
- ISO 9001 certified manufacturer
- Universal gearbox allows inch, metric, diametral, and module pitch threads, no change gears required
- One-piece cast iron base absorbs vibration allowing heavier cuts
- Removable gap allows up to 23-5/8" diameter work
- Five position automatic carriage stop increases productivity
- Large easy to use foot brake
- 3-1/8" bore spindle is supported by two tapered and one ball bearing
- Chrome molybdenum headstock gears are hardened, ground, and shaved
- Carriage features one-shot lubrication and Turcite B on bed sliding surfaces
- T-slotted compound slide featuring a four-way tool post
- High quality ANSI Class 50 wear-resistant cast iron bed ways are hardened and ground
- Attractive chrome control levers, dials, and knobs complete this impressive package

### STANDARD EQUIPMENT

- Tolerance test certificate
- 10" 3-jaw scroll chuck with top reversing jaws
- 12" 4-jaw independent chuck
- 12" face plate
- Four-way tool post
- Follow rest
- Large capacity steady rest
- Fully integrated coolant system
- Full length splash guard and coolant return
- Articulating halogen work lamp
- Centrally located controls with jog button
- Threading dial
- Mounting pads and levelers
- Spindle sleeve (MT-7 to MT-5)
- Dead center and live center





STOCK NUMBER	321910	321920
Model Number	GH-1440ZX	GH-1460ZX
Swing over Bed (in.)	14	14
Swing over Cross Slide (in.)	7-5/8	7-5/8
Swing Through Gap (in.)	18	18
Length of Gap (in.)	12	12
Distance Between Centers (in.)	40	60
Spindle Bore (in.)	3-1/8	3-1/8
Spindle Mount	D1-8	D1-8
Spindle Taper (w/ Sleeve)	MT-7 (MT-5)	MT-7 (MT-5)
Number of Spindle Speeds	12	12
Range of Spindle Speeds (RPM)	42 - 1,800	42 - 1,800
Number of Longitudinal and Cross Feed Rates	122	122
Range of Longitudinal Feeds (IPR)	.0015 - .0913	.0015 - .0913
Range of Cross Feeds (IPR)	.0006 - .0365	.0006 - .0365
Number of Inch Threads	61	61
Range of Inch Threads (TPI)	1-5/8 - 72	1-5/8 - 72
Number of Metric Threads	24	24
Range of Metric Threads	.05 - 20	.05 - 20
Max Tool Size (in.)	1 x 1	1 x 1
Compound Slide Travel (in.)	5-1/8	5-1/8
Cross Slide Travel (in.)	9	9
Carriage Travel (in.)	36-9/16	55-9/16
Tailstock Spindle Travel (in.)	5	5
Taper in Tailstock Spindle	MT-4	MT-4
Steady Rest Capacity (in.)	3/8 to 7	3/8 to 7
Follow Rest Capacity (in.)	1/2 - 3-1/2	1/2 - 3-1/2
Width of Bed (in.)	13-1/8	13-1/8
Overall Dimensions (in./ L x W x H)	96 x 44 x 66	116 x 44 x 66
Motor	7-1/2HP, 3Ph, 230V/460V Prewired 230V	7-1/2HP, 3Ph, 230/460V Prewired 230V
Net Weight (lbs.)	5,187	5,380



321910



Carriage Features One-Shot Lubrication and Turcite B on Sliding Surfaces



Clean, Simple Design and Well Marked Electrics Make Maintenance on These Lathes Easy!

#### GH-1440ZX LATHE AND ACCESSORY PACKAGES INSTALLED

GH-1440ZX with Taper Attachment	321467
GH-1440ZX with Collet Closer	321531
GH-1440ZX with Acu-Rite 200S 2 Axis DRO	321469
GH-1440ZX with Acu-Rite 200S 2 Axis DRO & Taper Attachment	321507
GH-1440ZX with Acu-Rite 200S 2 Axis DRO & Collet Closer	321501
GH-1440ZX with Acu-Rite 200S 2 Axis DRO, Taper Attachment & Collet Closer	321569
GH-1440ZX with Acu-Rite 300S 2 Axis DRO	321301
GH-1440ZX with Acu-Rite 300S 2 Axis DRO & Taper Attachment	321303
GH-1440ZX with Acu-Rite 300S 2 Axis DRO & Collet Closer	321304
GH-1440ZX with Acu-Rite 300S 2 Axis DRO, Taper Attachment & Collet Closer	321302
GH-1440ZX with Newall DP700 2-Axis DRO	321470
GH-1440ZX with Newall DP700 2-Axis DRO & Taper Attachment	321570
GH-1440ZX with Newall DP700 2-Axis DRO & Collet Closer	321441
GH-1440ZX with Newall DP700 2-Axis DRO, Collet Closer & Taper Attachment	321498
GH-1440ZX with Newall DP900 2-Axis DRO	321306
GH-1440ZX with Newall DP900 2-Axis DRO & Taper Attachment	321305
GH-1440ZX with Newall DP900 2-Axis DRO & Collet Closer	321307
GH-1440ZX with Newall DP900 2-Axis DRO, Taper Attachment & Collet Closer	321308

#### GH-1460ZX LATHE AND ACCESSORY PACKAGES INSTALLED

GH-1460ZX with Taper Attachment	321480
GH-1460ZX with Acu-Rite 200S 2 Axis DRO	321478
GH-1460ZX with Acu-Rite 200S 2 Axis DRO & Taper Attachment	321503
GH-1460ZX with Acu-Rite 200S 2 Axis DRO & Collet Closer	321490
GH-1460ZX with Acu-Rite 200S 2 Axis DRO, Taper Attachment & Collet Closer	321509
GH-1460ZX with Acu-Rite 300S 2 Axis DRO	321311
GH-1460ZX with Acu-Rite 300S 2 Axis DRO & Taper Attachment	321312
GH-1460ZX with Acu-Rite 300S 2 Axis DRO & Collet Closer	321315
GH-1460ZX with Acu-Rite 300S 2 Axis DRO, Taper Attachment & Collet Closer	321313
GH-1460ZX with Newall DP700 2-Axis DRO	321137
GH-1460ZX with Newall DP900 2-Axis DRO	321314
GH-1460ZX with Newall DP900 2-Axis DRO & Collet Closer	321585

#### CALL FOR ADDITIONAL PACKAGES

#### OPTIONAL EQUIPMENT

#### STOCK NUMBER

5C Lever-Type Collet Closer

321292



# 16", 18", AND 22" ZX SERIES LARGE SPINDLE BORE LATHES



## FEATURES

- Uniquely designed exclusively by JET
- ISO 9001 certified manufacturer
- 3-1/8" bore spindle is supported by two tapered and one ball bearing
- Universal gearbox allows inch, metric, diametral, and module pitch threads, no change gears required
- One-piece cast iron base absorbs vibration allowing heavier cuts
- High quality ANSI Class 50 wear-resistant cast iron bed ways are hardened and ground
- Large easy to use foot brake
- Chrome molybdenum headstock gears are hardened, ground, and shaved
- Carriage features one-shot lubrication and Turcite B on bed sliding surfaces
- T-slotted compound slide featuring a four-way tool post
- Removable gap allows up to 25-7/8" diameter work on 16", 27-1/2" on 18"
- Five position automatic carriage stop increases productivity
- Attractive chrome control levers, dials, and knobs complete this impressive package

## STANDARD EQUIPMENT

- Tolerance test certificate
- 10" 3-jaw scroll chuck with top reversing jaws
- 12" 4-jaw independent chuck
- 12" face plate (16" models)
- 16" face plate (18" models)
- Four-way tool post
- Follow rest
- Large capacity steady rest
- Fully integrated coolant system
- Full length splash guard and coolant return
- Articulating halogen work lamp
- Centrally located controls with jog button
- Threading dial
- Mounting pads and levelers
- Spindle sleeve (MT-7 to MT-5)
- Live center
- Tool box and adjusting tools



321930





STOCK NUMBER	321930	321940	321950	321960	321970	321980
Model Number	GH-1640ZX	GH-1660ZX	GH-1840ZX	GH-1860ZX	GH-1880ZX	GH-2280ZX
Swing over Bed (in.)	16	16	18	18	18	22
Swing over Cross Slide (in.)	10	10	11	11	11	13
Swing Through Gap (in.)	25-1/2	25-1/2	27-1/2	27-1/2	27-1/2	29-1/2
Length of Gap (in.)	12	12	12	12	12	12
Distance Between Centers (in.)	40	60	40	60	80	80
Spindle Bore (in.)	3-1/8	3-1/8	3-1/8	3-1/8	3-1/8	3-1/8
Spindle Mount	D1-8	D1-8	D1-8	D1-8	D1-8	D1-8
Spindle Taper (w/ Sleeve)	MT-7 (MT-5)	MT-7 (MT-5)	MT-7 (MT-5)	MT-7 (MT-5)	MT-7 (MT-5)	MT-7(MT-5)
Number of Spindle Speeds	12	12	12	12	12	12
Range of Spindle Speeds (RPM)	25 - 1,800	25 - 1,800	25 - 1,800	25 - 1,800	25 - 1,800	25 - 1,800
Number of Longitudinal and Cross Feed Rates	122	122	122	122	122	122
Range of Longitudinal Feeds (IPR)	.0015 - .0913	.0015 - .0913	.0015 - .0913	.0015 - .0913	.0015 - .0913	.0015 - .0913
Range of Cross Feeds (IPR)	.0006 - .0365	.0006 - .0365	.0006 - .0365	.0006 - .0365	.0006 - .0365	.0006 - .0365
Number of Inch Threads	61	61	61	61	61	61
Range of Inch Threads (TPI)	1-5/8 - 72	1-5/8 - 72	1-5/8 - 72	1-5/8 - 72	1-5/8 - 72	1-5/8 - 72
Number of Metric Threads	24	24	24	24	24	24
Range of Metric Threads	.05 - 20	.05 - 20	.05 - 20	.05 - 20	.05 - 20	.05 - 20
Max Tool Size (in.)	1 x 1	1 x 1	1 x 1	1 x 1	1 x 1	1 x 1
Compound Slide Travel (in.)	5-1/8	5-1/8	5-1/8	5-1/8	5-1/8	5-1/8
Cross Slide Travel (in.)	9	9	9	9	9	12
Carriage Travel (in.)	36-9/16	55-9/16	36-9/16	55-9/16	74-5/16	74-5/16
Tailstock Spindle Travel (in.)	5	5	5	5	5	5
Taper in Tailstock Spindle	MT-4	MT-4	MT-5	MT-5	MT-5	MT-5
Steady Rest Capacity (in.)	3/8 to 7	3/8 to 7	3/8 to 7-3/4	3/8 to 7-3/4	3/8 to 7-3/4	3/8 to 7-3/4
Follow Rest Capacity (in.)	1/2 - 3-1/2	1/2 - 3-1/2	1/2 - 3-1/2	1/2 - 3-1/2	1/2 - 3-1/2	1/2 - 3-1/2
Width of Bed (in.)	13-1/8	13-1/8	13-1/8	13-1/8	13-1/8	13-1/8
Overall Dimensions (in./ L x W x H)	96 x 44 x 66	115 x 44 x 66	96 x 44 x 66	115 x 44 x 66	136 x 44 x 66	136 x 45 x 71
Motor	7-1/2HP, 230/460V, 3Ph, Prewired 230V	7-1/2HP, 230/460V, 3Ph, Prewired 230V	7-1/2HP, 230/460V, 3Ph, Prewired 230V	7-1/2HP, 230/460V, 3Ph, Prewired 230V	7-1/2HP, 230/460V, 3Ph, Prewired 230V	10HP, 230/460V, 3Ph, Prewired 230V
Net Weight (lbs.)	5,475	5,795	5,980	6,245	6,590	6,933

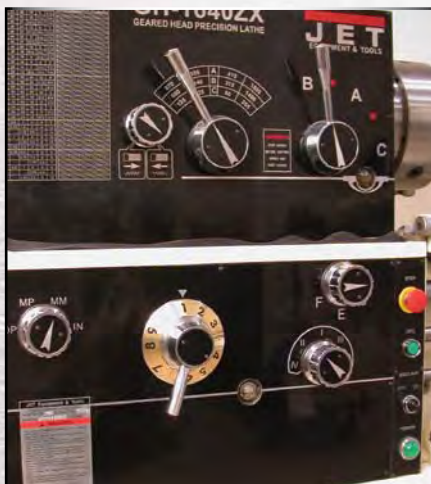

Attractive Chrome Control Levers, Dials and Knobs Complete this Package



Large 3-1/8" Spindle Bore



Every JET ZX Lathe Comes with a Four-Way Tool Post





# 16", 18", AND 22" ZX SERIES LARGE SPINDLE BORE LATHE PACKAGES

## GH-1640ZX LATHE AND ACCESSORY PACKAGES INSTALLED

GH-1640ZX with Taper Attachment	321474
GH-1640ZX with Collet Closer	321439
GH-1640ZX with Acu-Rite 200S 2 Axis DRO	321475
GH-1640ZX with Acu-Rite 200S 2 Axis DRO & Taper Attachment	321508
GH-1640ZX with Acu-Rite 200S 2 Axis DRO & Collet Closer	321495
GH-1640ZX with Acu-Rite 200S 3- Axis DRO	321525
GH-1640ZX with Acu-Rite 300S 2 Axis DRO	321381
GH-1640ZX with Acu-Rite 300S 2 Axis DRO & Taper Attachment	321382
GH-1640ZX with Acu-Rite 300S 2 Axis DRO & Collet Closer	321383
GH-1640ZX with Newall DP700 2-Axis DRO	321138
GH-1640ZX with Newall DP700 2-Axis DRO & Taper Attachment	321148
GH-1640ZX with Newall DP700 2-Axis DRO & Collet Closer	321494
GH-1640ZX with Newall DP700 2-Axis DRO, Collet Closer & Taper Attachment	321147
GH-1640ZX with Newall DP900 2-Axis DRO	321384
GH-1640ZX with Newall DP900 2-Axis DRO & Taper Attachment	321385
GH-1640ZX with Newall DP900 2-Axis DRO & Collet Closer	321380
GH-1640ZX with Newall DP900 2-Axis DRO, Taper Attachment & Collet Closer	321386

## GH-1660ZX LATHE AND ACCESSORY PACKAGES INSTALLED

GH-1660ZX with Taper Attachment	321477
GH-1660ZX with Collet Closer	321573
GH-1660ZX with Taper Attachment & Collet Closer	321544
GH-1660ZX with Acu-Rite 200S 2 Axis DRO	321455
GH-1660ZX with Acu-Rite 200S 2 Axis DRO & Taper Attachment	321543
GH-1660ZX with Acu-Rite 200S 2 Axis DRO & Collet Closer	321440
GH-1660ZX with Acu-Rite 200S 2 Axis DRO, Taper Attachment & Collet Closer	321576
GH-1660ZX with Acu-Rite 200S 3- Axis DRO	321530
GH-1660ZX with Acu-Rite 300S 2 Axis DRO	321388
GH-1660ZX with Acu-Rite 300S 2 Axis DRO & Taper Attachment	321389
GH-1660ZX with Acu-Rite 300S 2 Axis DRO & Collet Closer	321390
GH-1660ZX with Acu-Rite 300S 2 Axis DRO, Taper Attachment & Collet Closer	321391
GH-1660ZX with Newall DP700 2-Axis DRO	321139
GH-1660ZX with Newall DP700 2-Axis DRO & Taper Attachment	321529
GH-1660ZX with Newall DP700 2-Axis DRO & Collet Closer	321527
GH-1660ZX with Newall DP700 2-Axis DRO, Collet Closer & Taper Attachment	321502
GH-1660ZX with Newall DP900 2-Axis DRO	321392
GH-1660ZX with Newall DP900 2-Axis DRO & Taper Attachment	321393
GH-1660ZX with Newall DP900 2-Axis DRO & Collet Closer	321394
GH-1660ZX with Newall DP900 2-Axis DRO, Taper Attachment & Collet Closer	321387



Newall DP700 - DRO



Acu-Rite 200S - DRO



**J E T**



# 16", 18", AND 22" ZX SERIES LARGE SPINDLE BORE LATHE PACKAGES

## GH-1840ZX LATHE AND ACCESSORY PACKAGES INSTALLED

GH-1840ZX with Taper Attachment	321466
GH-1840ZX with Acu-Rite 200S 2 Axis DRO	321481
GH-1840ZX with Acu-Rite 200S 2 Axis DRO & Taper Attachment	321483
GH-1840ZX with Acu-Rite 200S 2 Axis DRO & Collet Closer	321448
GH-1840ZX with Acu-Rite 200S 2 Axis DRO, Taper Attachment & Collet Closer	321454
GH-1840ZX with Acu-Rite 300S 2 Axis DRO	321415
GH-1840ZX with Acu-Rite 300S 2 Axis DRO & Taper Attachment	321418
GH-1840ZX with Acu-Rite 300S 2 Axis DRO & Collet Closer	321416
GH-1840ZX with Acu-Rite 300S 2 Axis DRO, Taper Attachment & Collet Closer	321417
GH-1840ZX with Newall DP700 2-Axis DRO	321650
GH-1840ZX with Newall DP700 2-Axis DRO & Collet Closer	321655
GH-1840ZX with Newall DP700 2-Axis DRO, Collet Closer & Taper Attachment	321657
GH-1840ZX with Newall DP900 2-Axis DRO	321419

## GH-1860ZX LATHE AND ACCESSORY PACKAGES INSTALLED

GH-1860ZX with Taper Attachment	321463
GH-1860ZX with Taper Attachment & Collet Closer	321961
GH-1860ZX with Acu-Rite 200S 2 Axis DRO	321484
GH-1860ZX with Acu-Rite 200S 2 Axis DRO & Taper Attachment	321504
GH-1860ZX with Acu-Rite 200S 2 Axis DRO & Collet Closer	321491
GH-1860ZX with Acu-Rite 200S 2 Axis DRO, Taper Attachment & Collet Closer	321505
GH-1860ZX with Acu-Rite 300S 2 Axis DRO	321590
GH-1860ZX with Acu-Rite 300S 2 Axis DRO & Taper Attachment	321591
GH-1860ZX with Acu-Rite 300S 2 Axis DRO & Collet Closer	321592
GH-1860ZX with Acu-Rite 300S 2 Axis DRO, Taper Attachment & Collet Closer	321593
GH-1860ZX with Newall DP700 2-Axis DRO	321485
GH-1860ZX with Newall DP700 2-Axis DRO & Taper Attachment	321452
GH-1860ZX with Newall DP700 2-Axis DRO, Collet Closer & Taper Attachment	321557
GH-1860ZX with Newall DP900 2-Axis DRO	321594

## GH-1880ZX LATHE AND ACCESSORY PACKAGES INSTALLED

GH-1880ZX with Taper Attachment	321486
GH-1880ZX with Taper Attachment & Collet Closer	322486
GH-1880ZX with Acu-Rite 200S 2 Axis DRO	321487
GH-1880ZX with Acu-Rite 200S 2 Axis DRO & Taper Attachment	321560
GH-1880ZX with Acu-Rite 200S 2 Axis DRO & Collet Closer	321492
GH-1880ZX with Acu-Rite 200S 2 Axis DRO, Taper Attachment & Collet Closer	321493
GH-1880ZX with Acu-Rite 300S 2 Axis DRO	321595
GH-1880ZX with Acu-Rite 300S 2 Axis DRO & Taper Attachment	321597
GH-1880ZX with Acu-Rite 300S 2 Axis DRO & Collet Closer	321598
GH-1880ZX with Acu-Rite 300S 2 Axis DRO, Taper Attachment & Collet Closer	321599
GH-1880ZX with Newall DP700 2-Axis DRO	321488
GH-1880ZX with Newall DP700 2-Axis DRO & Taper Attachment	321571
GH-1880ZX with Newall DP900 2-Axis DRO	321596
GH-1880ZX with Newall DP900 2-Axis DRO & Taper Attachment	321600

## GH-2280ZX LATHE AND ACCESSORY PACKAGES INSTALLED

GH-2280ZX with Taper Attachment	321565
GH-2280ZX with Collet Closer	321496
GH-2280ZX with Taper Attachment & Collet Closer	321575
GH-2280ZX with Acu-Rite 200S 2 Axis DRO	321879
GH-2280ZX with Acu-Rite 200S 2 Axis DRO & Taper Attachment	321567
GH-2280ZX with Acu-Rite 200S 2 Axis DRO & Collet Closer	321566
GH-2280ZX with Acu-Rite 200S 2 Axis DRO, Taper Attachment & Collet Closer	321568
GH-2280ZX with Acu-Rite 300S 2 Axis DRO	321610
GH-2280ZX with Acu-Rite 300S 2 Axis DRO & Taper Attachment	321612
GH-2280ZX with Acu-Rite 300S 2 Axis DRO & Collet Closer	321613
GH-2280ZX with Acu-Rite 300S 2 Axis DRO, Taper Attachment & Collet Closer	321615
GH-2280ZX with Newall DP700 2-Axis DRO	321880
GH-2280ZX with Newall DP700 2-Axis DRO & Taper Attachment	321881
GH-2280ZX with Newall DP700 2-Axis DRO, Collet Closer & Taper Attachment	321579
GH-2280ZX with Newall DP900 2-Axis DRO & Taper Attachment	321614

CALL FOR ADDITIONAL PACKAGES





# CL-1640ZX-CNC LATHE WITH ANILAM 4200T CONTROL

## FEATURES

- Anilam 4200T with 12.1 TFT Flat Screen CNC Control
- Dual electronic handwheels for manual control
- Hardened and precision ground bed ways
- High alloy gears hardened, ground and honed
- 3-Bearing spindle support
- Automatic homing
- Easy access chip removal
- 4 Station Programmable Turret
- Automatic lubrication system
- Coolant system with 5.5 gallon coolant tank
- Teach In Mode
- 255 Pairs of Tool Offsets
- Rigid Tapping is Standard
- Turcite B on carriage sliding surfaces

## STANDARD EQUIPMENT

- Tool box and tools
- Fully enclosed Cabinet
- 10" 3-jaw chuck
- 16" Face plate
- Steady Rest
- Work light

**NEW!**



**J E T**





**MANUAL MODE:**

In manual mode, the lathe can be operated just as simply if it had been a conventional lathe. Up to two electronic hand-wheels can be connected to run the axes. In addition, the 4200T provides a wealth of data and many useful features, for example constant surface speed (CSS).



**SEMI-AUTOMATIC MODE:**

The dual hand-wheel mode allows the machinist to cut in perfect arcs, tapers and chamfers. As only one hand-wheel is cranked, the 4200T will precisely control both axes to produce the desired shape.

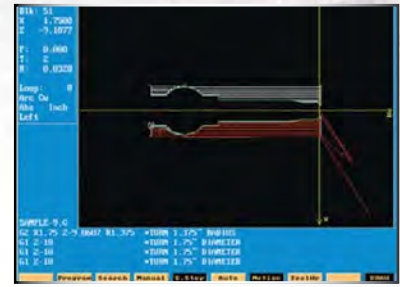

**AUTOMATIC MODE:**

During automatic operation, the 4200T will control everything from start to finish. The machinist has several options on how to generate the program and some very powerful programming tools are available.



STOCK NUMBER	320930
Model Number	CL-1640ZX-CNC
Swing over Bed (in.)	16
Swing Through Gap (in.)	25-7/8
Distance Between Centers (in.)	40
Spindle Bore (in.)	3-1/8
Spindle Mount	D1-8
Spindle Taper (w/ Sleeve)	MT-7 (MT-5)
Range of Spindle Speeds (RPM)	80 - 2000
Rapid Feed, X-Axis (in./min.)	394
Rapid Feed, Y-Axis (in./min.)	315
Max Tool Size (in.)	1 x 1
Cross Slide Travel (in.)	9
Carriage Travel (in.)	35
Tailstock Spindle Travel (in.)	6
Taper in Tailstock Spindle	MT-4
Steady Rest Capacity (in.)	3/8 to 7
Width of Bed (in.)	13-1/4
Motor	10HP, 230V, 3Ph
Net Weight (lbs.)	5,680



**FREE** 4 HOURS OF IN-HOUSE TRAINING CNC TRAINING FROM ANILAM





## TOOL POST SETS

SERIES 200, 300 & 400 WEDGE TYPE POST SETS

- #1 Boring & Facing
- #2 Boring, Turning & Facing
- #4 Boring, Heavy Duty
- #7 Universal Parting Blade
- #10 Knurling, Facing & Turning
- Working parts hardened and ground
- Maximum rigidity for chatter-free performance
- Holders fit ALORIS and YUASA tool posts
- Increases productivity of all lathe operations
- Completely sealed for maintenance free operation
- Change tools in seconds

STOCK NUMBER	650295	650300	650305
Series	200 (BXA)	300	400 (CA)
Fits Swing Lathe Size (in.)	10 - 15	10 - 18	14 - 20
Net Weight (lbs.)	6	6	7



650300

## 5-C COLLET SETS & RACKS

- Precision hardened and ground
- C Collets for use on lathes
- Premium collets with 0.0005mm T.I.R.

STOCK NUMBER	DESCRIPTION
650014	CS-5C 16 pcs 5-C collet set 1/8" to 1 1/16" by 1/16th
650015	18 pc Premium 5C collet set 1/16" to 1-1/8" by 16th with Metal Rack
650016	35 pc Premium 5C collet set 1/16" to 1-1/8" by 32nds with Metal Rack
650017	Metal collet rack holds 30 5C collets
650018	Metal collet rack holds 72 5C collets



650014

650015

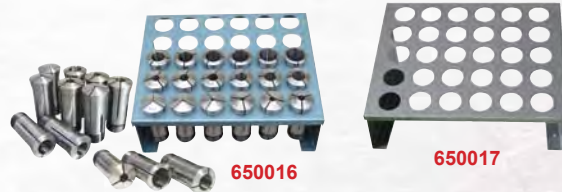

650016

650017

## COOLANT SYSTEM

- For use with BDB-1340, GHB-1340 & GHB 1440
- 1/8 HP, 115V 3 gallon per minute flow rate
- Requires drilling of chip pan

STOCK NUMBER	DESCRIPTION
321444	CP-13BD, Coolant Pump Kit for 321357A and 321360A







## TOOLING KITS

22 & 23 PIECE SETS FOR JET LATHES

### 660200 Kit Includes

- Three double ended boring bars
- Parting tool holder
- Adjustable turning tool holder
- Revolving knurling tool with three pairs of knurls
- Half dead center
- Carbide tipped dead center
- Heavy-duty live center
- Cut off tool
- Eight HSS tool bits
- Four hex key wrenches
- Works with 13" and 14" W Series and Bench Series Lathes

### 660210 Kit Includes

- Three double ended boring bars
- Parting tool holder
- Adjustable turning tool holder
- Revolving knurling tool with three pairs of knurls
- Half dead center
- Carbide tipped dead center
- Heavy-duty live center
- Cut off tool
- Eight HSS tool bits
- Four hex key wrenches
- Works with all ZX Series Lathes



STOCK NUMBER	DESCRIPTION
660200	22-piece Turning Tool Kit for 13" & 14" W Series & Bench Series Lathes
660210	23-piece Turning Tool Kit for all ZX Series Lathes

## TAPER ATTACHMENTS

- Specially designed for each model
- 10° inclusive cutting capacity
- Mounts to predrilled and tapped holes
- Factory installation available

STOCK NUMBER	MODEL NUMBER	MAX. TAPER LENGTH (IN.) AT 10° ANGLE
321442	BDB-1340A	10
321442	GHB-1340A	10
321520	All W models	10-5/8
321291	All ZX models	18



## COLLET CLOSER

- Specially designed for each model
- Precision ground components
- Uses 5C collets
- Rear mounted lever action
- Some drilling and other modification may be required

STOCK NUMBER	MODEL NUMBER
321515A	BDB-1340A
321514A	GHB-1340A
321519	All W models
321292	All ZX models





# ACU-RITE DIGITAL READOUTS FOR TURNING

## VUE

The Acu-Rite VUE is a cost-effective, entry-level solution for manual machine tool applications. With our innovative LCD display screen technology and versatile software to accommodate milling, turning or grinding applications the VUE is everything you need at a price you can afford.

### Common Features

- 1, 2 or 3 axis 5.7" Transmissive LCD display
- Job Clock
- Feed Rate Display
- Multiple Language Support
- Absolute/Incremental
- Near-Zero Warning
- Help Function
- 16 Tool Offsets/Diameter
- Preset and zero reset
- 4 Function Calculator/Trig Calculator
- Instant Inch/mm conversion
- 200mm Fixed Reference Marks

### Turning Specific Features

- Lock axis feature—used in conjunction with tool offsetting; lets you establish tool offsets with the tool under load, resulting in reduced tool deflection.
- Instant radius/diameter conversion

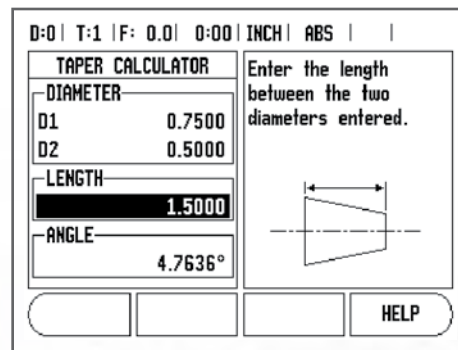

## 200S

As the industry standard in digital readout systems, the Acu-Rite 200S offers state-of-the-art features for milling, turning and grinding applications.

### Common Features

- 2 or 3 axis 5.7" Transmissive LCD display
- Job Clock
- Feed Rate Display
- Multiple Language Support
- Absolute/Incremental
- Near-Zero Warning
- Help Function
- 16 Tool Offsets/Diameter
- Preset and zero reset
- 4 Function Calculator/Trig Calculator
- Instant Inch/mm conversion
- Position-Trac™ Home Reference

### Turning Specific Features

- Lock axis feature
- Instant radius/diameter conversion
- Taper Calculator
- CSS (option)

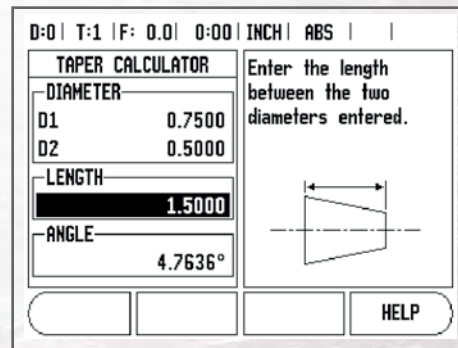



# ACU-RITE DIGITAL READOUTS FOR TURNING

## 300S

The Acu-Rite 300S is a fully programmable 4 axis readout system, now available with a full color display. With the capability to store and create a library of programs the 300S is everything you need to create, edit and execute programs on your manual machine tool.

### Common Features

- 2, 3 or 4 axis 5.7" Full Color Display
- Multiple program names with numerous steps
- Multiple display views
- Job Clock
- Feed Rate Display
- Multiple Language Support
- Absolute/Incremental
- Near-Zero Warning
- Help Function
- 16 Tool Offsets/Diameter
- Preset and zero reset
- 4 Function Calculator/Trig Calculator
- Instant Inch/mm conversion
- Position-Trac™ Home Reference

### Turning Specific Features

- Lock axis feature
- Instant radius/diameter conversion
- Taper Calculator

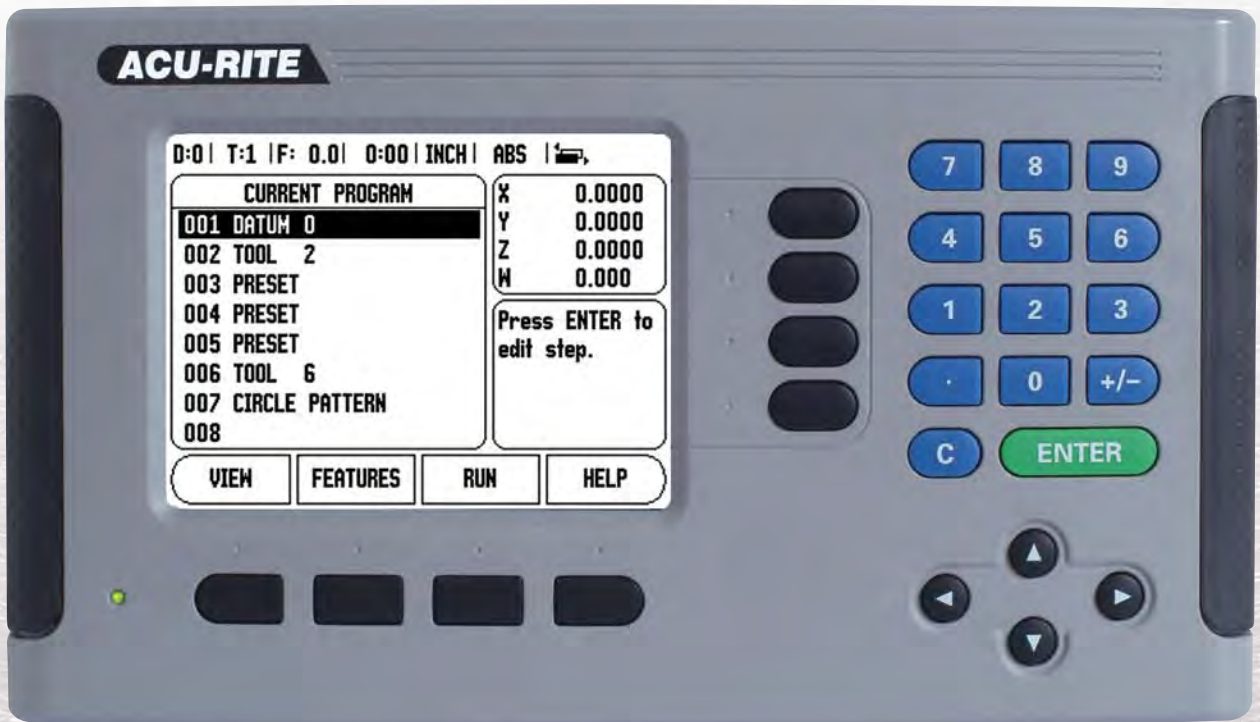
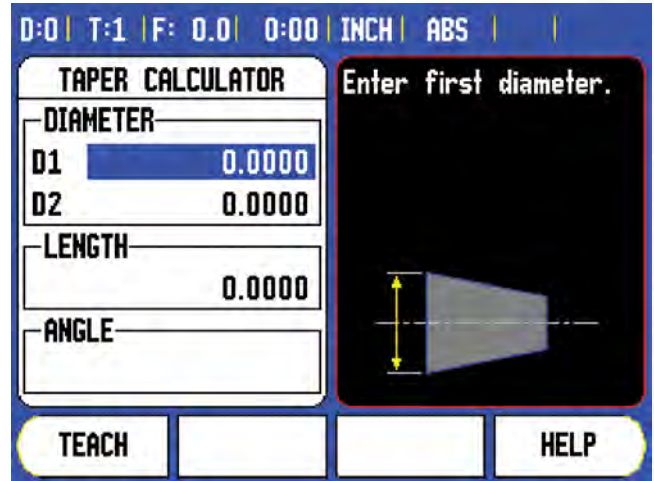

# TURNING



# NEWALL DIGITAL READOUTS FOR TURNING

# NEWALL

## DP700

The DP700 is the latest in Newall's line of a powerful and intuitive DROs. The unit is housed in a rugged, ergonomically designed casting. The DRO features all of the essential functions for milling, boring, turning, grinding, and general machining operations.

### Common Features

- Clean, Crisp, Easy to Read, LEDs
- Intuitive Message Window
- Long Life Membrane Keypad
- Solid cast construction
- Safe, Low Voltage Power Supply (UL)
- Panel Mount Version Available
- Feed Rate Display
- Bolt Hole Circle Routine
- Line Hole Routine
- Arc Contouring
- Programmable Memory/Teach
- Polar Coordinates
- Line Hole Calculator
- Tool Offsets
- Taper Calculations
- Axis Vectoring/Summing
- Linear and Segmented Error Comp.
- Undo
- RS232 Output
- Languages: English, French, German, Spanish, Italian, Turkish, Czech, Russian, Portuguese, Danish

The DP700 is compatible with Newall's Spherosyn and Microsyn encoders which withstand the harshest shop conditions.



## DP900

Setting new performance standards, the DP900 integrates the latest innovations in electronic design, housed in a rugged die-cast chassis. The feather-touch keypad ensures long life and stability throughout the rugged shop environment. The DRO offers flexible features tailored for milling or turning applications. Plus, with the use of a touch probe, part inspection calculations can be performed without removing the part from the machine.

### Common Features

- Rugged Die-Cast Chassis
- Feather-Touch, Cap-Sense Keypad
- 5.7" QVGA Blue STN with CCFL Backlight
- 2, 3, or 4 Axis with Optional Rotary Axis
- Graphical Tool Path Verification
- Customized Canned Cycles
- Remote Storage via USB Port
- CMM / Inspection Functions with Probe Capabilities
- Feed Rate Display
- Polar Co-ordinate Readings
- Touch Probe Input
- Teach Mode with Graphics

### Turning Specific Features

- Taper Calculation
- Vectoring
- Tool Offsets (99)
- Axis Summing
- Radius / Diameter Readings



# JET







# JET

## EXPAND YOUR CAPABILITIES.

JET manufactures a full range of metalworking products to complete your shop. When you're ready to expand your shops capabilities, go to JET for consistent quality, innovation and service across all metalworking categories.



**SAWING**



**MILLING**



**DRILLING**

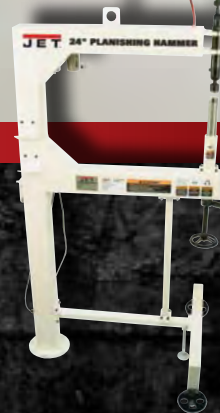

**FORMING**



**FINISHING**

**CONTACT YOUR LOCAL SALES REPRESENTATIVE OR VISIT [JETTOOLS.COM](http://JETTOOLS.COM) FOR MORE INFORMATION.**





# WARRANTY AND SERVICE

## WARRANTY AND SERVICE

Walter Meier (Manufacturing) Inc., warrants every product it sells. If one of our tools needs service or repair, one of our Authorized Service Centers located throughout the United States can give you quick service. In most cases, any of these Walter Meier Authorized Service Centers can authorize warranty repair, assist you in obtaining parts, or perform routine maintenance and major repair on your JET tools. For the name of an Authorized Service Center in your area call **1-800-274-6848**.

## MORE INFORMATION

Walter Meier is consistently adding new products to the line. For complete, up-to-date product information, check with your local Walter Meier distributor, or visit [jettools.com](http://jettools.com)

## WARRANTY

JET products carry a limited warranty which varies in duration based upon the product.

**2**  
WARRANTY  
**YEAR**

- Metalforming
- Mill/Drills
- Milling Machines
- MW Bandsaws
- MW Drill Presses
- MW Finishing Equipment
- MW Lathes

**90**  
WARRANTY  
**DAY**

- Lathe Accessories
- Machine Accessories

## WHAT IS COVERED?

This warranty covers any defects in workmanship or materials subject to the exceptions stated below. Cutting tools, abrasives and other consumables are excluded from warranty coverage.

## WHO IS COVERED?

This warranty covers only the initial purchaser of the product.

## WHAT IS THE PERIOD OF COVERAGE?

The general JET warranty lasts for the time period specified in the product literature of each product.

## HOW TO GET SERVICE

The product or part must be returned for examination, postage prepaid, to a location designated by us. For the name of the location nearest you, please call **1-800-274-6848**.

You must provide proof of initial purchase date and an explanation of the complaint must accompany the merchandise. If our inspection discloses a defect, we will repair or replace the product, or refund the purchase price, at our option.

We will return the repaired product or replacement at our expense unless it is determined by us that there is no defect, or that the defect resulted from causes not within the scope of our warranty in which case we will, at your direction, dispose of or return the product. In the event you choose to have the product returned, you will be responsible for the shipping and handling costs of the return.

## HOW STATE LAW APPLIES

This warranty gives you specific legal rights; you may also have other rights which vary from state to state.

## LIMITATIONS ON THIS WARRANTY

WALTER MEIER LIMITS ALL IMPLIED WARRANTIES TO THE PERIOD OF THE LIMITED WARRANTY FOR EACH PRODUCT. EXCEPT AS STATED HEREIN, ANY IMPLIED WARRANTIES OR MERCHANTABILITY AND FITNESS ARE EXCLUDED. SOME STATES DO NOT ALLOW LIMITATIONS ON HOW LONG THE IMPLIED WARRANTY LASTS, SO THE ABOVE LIMITATION MAY NOT APPLY TO YOU. WALTER MEIER SHALL IN NO EVENT BE LIABLE FOR DEATH, INJURIES TO PERSONS OR PROPERTY, OR FOR INCIDENTAL, CONTINGENT, SPECIAL, OR CONSEQUENTIAL DAMAGES ARISING FROM THE USE OF OUR PRODUCTS. SOME STATES DO NOT ALLOW THE EXCLUSION OR LIMITATION OF INCIDENTAL OR CONSEQUENTIAL DAMAGES, SO THE ABOVE LIMITATION OR EXCLUSION MAY NOT APPLY TO YOU.

Walter Meier sells through distributors only. The specifications in Walter Meier catalogs are given as general information and are not binding. Members of Walter Meier reserve the right to effect at any time, without prior notice, those alterations to parts, fittings, and accessory equipment which they may deem necessary for any reason whatsoever. JET® branded products are not sold in Canada by Walter Meier.





Stock No. 904261

5K 9-2010

©2010 Walter Meier (Manufacturing) Inc. :: Printed in the U.S.A.

Walter Meier (Manufacturing) Inc.

Laverne, TN 37086 U.S.A.

[waltermeier.com](http://waltermeier.com)