

# KAZMIER TOOLING INC.



## KAZMIER TOOLING

# AHB

TOOLING & MACHINERY

COMPLETE  
METALWORKING SOLUTIONS

(800) 991-4225

[www.ahbinc.com](http://www.ahbinc.com)

ISO Certified

[customerservice@ahbinc.com](mailto:customerservice@ahbinc.com)



		height)	1.5
			2
			2.5
			3
			3.5
			4
			1.5
			2
			3
			3.5
			4
			5
			3.5
			4
			5
			4
			4
			5

SPECIALIZING IN PRESS BRAKE TOOLING

# Kazmier Tooling Inc.

---

## Table of Contents:

Ordering Instructions .....	2
Safety Warning .....	2
Material Specifications .....	3
Special Ordering Conditions .....	3
Terms and Payment .....	5

## Standard Punches and Dies:

90° Forming Punches and Dies .....	6
Gooseneck Punches .....	8
Acute Forming Punches and Dies .....	10
Offset Die Sets .....	11
Flattening Die Sets .....	12
Adjustable Bottom Dies .....	13
Box Forming Punches .....	14
4-Way / 3-Way bottom Dies .....	16
Die Holders, Riser Blocks, and Ram Adapters.....	17

## Special Die Sets:

Special Offset Die Sets .....	18
Hemming and Standing Seam Die sets .....	19
Radius Die Sets .....	21
Curling Die Sets.....	22
Channel Die Sets .....	24
Rib and Corrugating Die Sets .....	25
Wiping and Rocker Dies.....	26
Special Application Dies .....	27
European Style 90° Tooling .....	28
European Style Acute Tooling .....	29
Examples of Common Shapes .....	31
Air Forming Tonnage Chart .....	32

## How to Order:

1. Specify Tooling Part Number.
2. Die Opening.
3. Gauge and Material Type of Stock.
4. Length Required.
5. Options:
  - a. Cut Lengths
  - b. Segmenting (Cut and Mill)
  - c. Flame Hardening
  - d. Safety Tang
  - e. Microfine Polishing

## Special Die Sets:

1. Provide a drawing or sample of finished part.
2. Specify gauge and type of material to be formed.
3. Indicate press brake tonnage, type, die space, stroke and ram adjustment.
4. Indicate number of hits desired to form part.
5. Indicate if we are matching a shut height.
6. If matching existing tooling, provide a 2 inch (minimum) sample.
7. Indicate critical dimensions and tolerances.

---

**Kazmier Tooling Inc.**  
6001 S. Oak Park Avenue  
Chicago, Illinois 60638  
Phone: (773) 586-0300  
Fax: (773) 586-6777  
E-mail: kaztool@aol.com

## SAFETY WARNING

At Kazmier Tooling, every possible effort is made to ensure that the tooling you ordered will produce parts that meet your specifications. You the user must understand that you have the responsibility for ensuring that the tooling is used for the application it was designed for and that all applicable safety procedures are followed. Safety and industrial standards should always be considered and applied to ensure effective operation and protection.

Our tooling is not intended to be used in equipment without a means provided for preventing hands or other parts of the body from entering or remaining in the die space at any time.

When using press brake tooling, comply with all safety requirements in the American National Standard Institute (ANSI) Bulletin ANSI #B11-3 as well as all internal safe operating procedures, machinery warnings and cautions, and local, state and federal standards which may apply.

A copy of ANSI #B11-3 may be obtained from the American National Standard Institute, Incorporated at 1430 Broadway, New York, N.Y. 10018



# Kazmier Tooling Inc.

---

## Tooling Steel Specifications

---

Unless otherwise indicated, all Kazmier Press Brake Tooling is made from high quality alloy steel specially engineered for press brake tooling applications. This medium carbon alloy offers excellent strength and durability. It is easily machined and can be flame hardened to increase its durability.

- **Hardness:** 265-321 on the Brinell Scale, 28-32 on the Rockwell "C" Scale
- **Machinability:** This steel is easily machined and milled in its prehardened condition. Die surfaces are easily polished due to rigid quality control standards insuring a uniform ASTM grain size between 5 and 8.
- **Additional Hardening:** This steel can be flame hardened to a depth of up to .125" (3.1mm) on work surfaces. This increases the hardness to 480-560 on the Brinell Scale, 50-55 on the Rockwell "C" Scale. It can be remachined after flame hardening provided that it is annealed first.

## Die Holder/Riser Block Specifications

---

In order to provide a good base for your dies, we machine A36 plate to the finished sizes of your order. Normally holders will be made an inserted tongue for mounting in the press brake. Other options are available as shown on page 15 for an additional charge. Please specify what type of mounting system you want on your holder when requesting a quote or placing an order.

## Special Ordering Considerations

---

We want you to be satisfied with your tooling. Every effort will be made to ensure that your order meets or exceeds your expectations. Our experience in the special situations below will help to ensure that your tooling works as expected.

- **Safety Tang/Hook Tongues:** We recommend safety tongues on all punches with 5-3/4" Net Height or greater, in cases where stripping pressure is applied, and for segmented punches shorter than 6" in length. When ordering a safety tongue on asymmetrical punches, such as gooseneck punches, please specify the direction of the tongue. Typical dimensioning of safety tongues and standard tongues are on page 6. Note that ordering a safety tang on a standard punch will reduce the net height of the tool by .125" (3.1mm).

# Kazmier Tooling Inc.

---

- **Flame Hardening:** Flame hardening is available as an option on most standard and special punches and dies. We recommend flame hardening for wire and stainless steel applications. This process increases hardness to a depth of approximately .125" (3.18mm) on work surfaces. We do not recommend the flame hardening of narrow surfaces such as acute punches.
- **European Style Holders:** All tooling is quoted and shown with standard tongues or safety tongues. For an additional charge, we can design and manufacture tooling with European Style Holders.
- **Unit of Measure:** All dimensions are given in inch / fractional notation. Metric / decimal dimensions are not a problem. We will be happy to quote your metric tooling requirements.
- **Try-out Material:** When designing specialized tooling for your application, we may ask for try-out material. Providing try-out material is an important part of ensuring that you are satisfied with the performance of the tooling. Because of wide variations in materials from supplier to supplier and the effect these variations have on the performance of your tooling, it is critical that we have your material as part of our quality control process. All that is required is ten to twelve pieces of material of sufficient size to show the profile of your part. Not sending try-out material may delay your order and effect the performance of your tooling.
- **Reconditioning of Existing Tooling:** Often we are able to rework existing tooling at a fraction of the cost of new tooling. We pride ourselves on quick turn-around for reconditioning your tooling. Please note that prices quoted are estimated and actual prices will be quoted after inspection of your tooling.
- **Approval Drawings:** It is our policy to provide drawings for your review and approval concerning all special die sets. We will on request, forward drawings for standard tooling ordered. When quoting specialized tooling, a drawing may be provided to clarify what we quoted to you.



# Kazmier Tooling Inc.

---

- **Die Finish:** We make every effort to provide a mar free surface finish on all Kazmier press brake tooling. In situations where you require minimal marking on your formed part, we can provide a superfine polished finish (10 mirco inch) at a small additional cost.

## Terms and Conditions

---

- **Credit:** All orders are accepted subject to the approval of our credit department. First time orders will be accepted for Cash down or COD. New accounts may request terms by furnishing us three trade and one banking reference. This may delay your order as we cannot control how quickly your references will respond to our credit inquiries.

- **Payment:** Terms are net thirty days unless otherwise stated as a condition of sale on a quote. Acceptable payment is a check or money order for U.S. funds. All prices are FOB our factory and are subject to change without notice.

- **Cancellation:** In the event that you cancel an order, we reserve the right to charge for any expended material, labor and overhead.

- **Returned Items:** A restocking charge of 15% will be assessed on all returned unused standard tooling. Written permission and shipping instructions must be obtained prior to returning any standard tooling. Special tooling cannot be returned. Kazmier Tooling Inc. is not responsible for any freight charges related to returned tooling.

# Standard Tooling

All standard tooling is stocked and available for quick delivery. The tooling illustrated below is recommended for the gauge indicated.

Punches KP1, KP2, KP1B and KP3 are for bottom forming at 90°. Through air forming, you can achieve angles greater than 90° by adjusting the ram to control the distance the punch penetrates into the die. Punches KP4, KP5 and KP6 are designed for use with heavier gauge material or plate. They are manufactured with an 85° forming angle in order to air form and must be used with lower dies that have the same angle. This air forming reduces the overall tonnage required to form the shape. Ideally, the lower die opening is 8 times the material thickness of metals up to 1/2" plate and 10 times material thickness for material greater than 1/2" plate. Safety tongue reduces net height by 1/8".

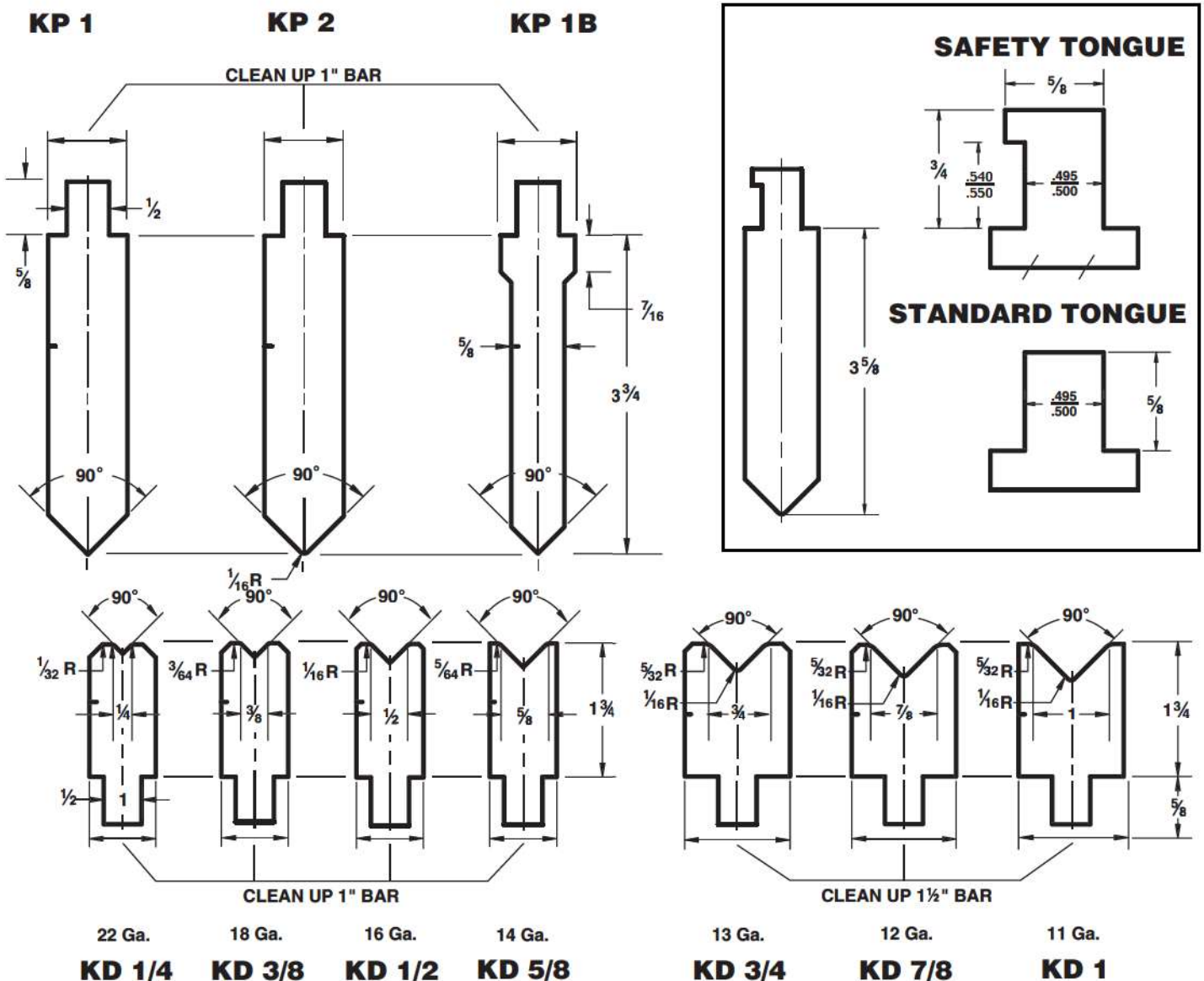

# 90° Forming Punches and Dies

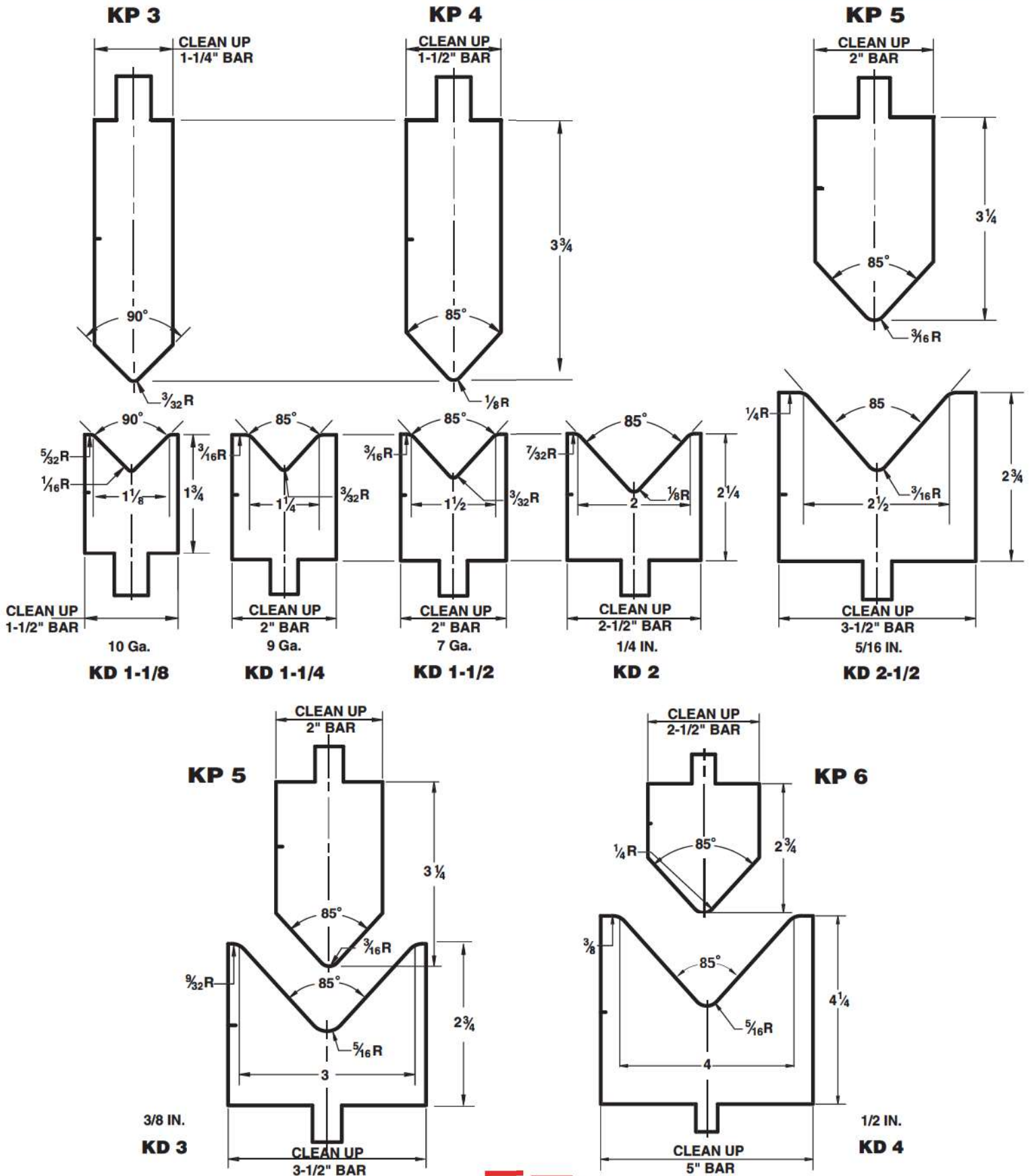

# Gooseneck Punches

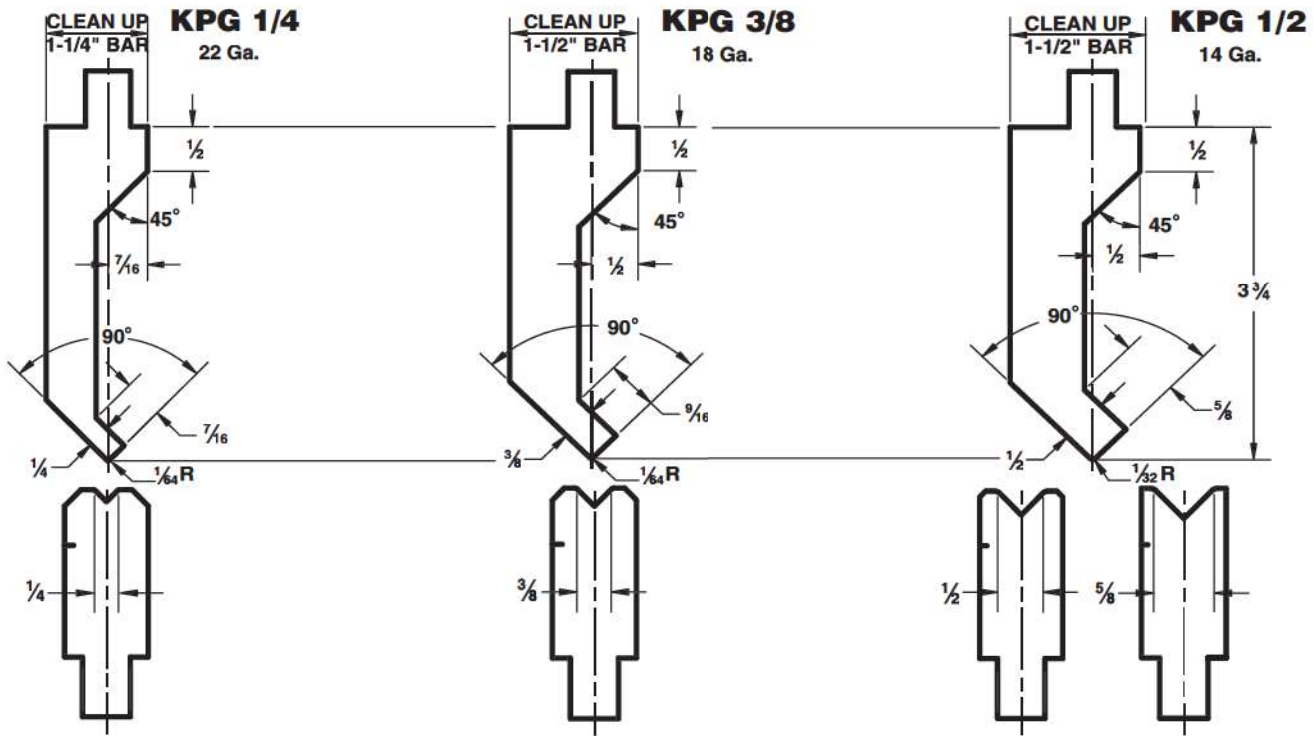

22 Ga.  
**KD 1/4**

18 Ga.  
**KD 3/8**

16 Ga.      14 Ga.  
**KD 1/2      KD 5/8**

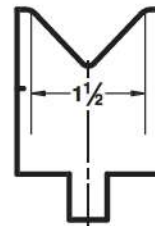
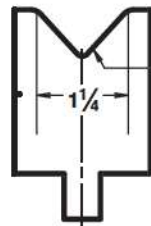
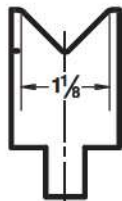
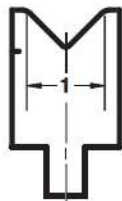
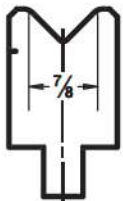
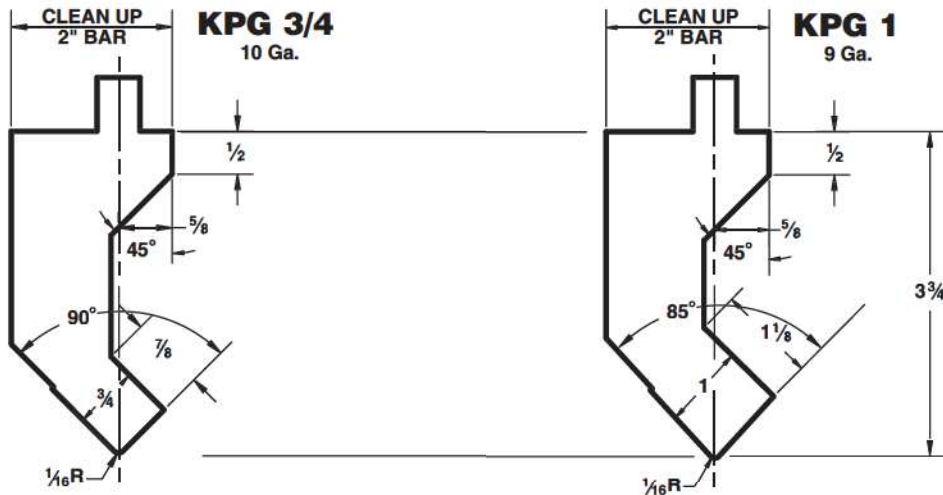

12 Ga.  
**KD 7/8**

11 Ga.  
**KD 1**

10 Ga.  
**KD 1-1/8**

9 Ga.  
**KD 1-1/4**

7 Ga.  
**KD 1-1/2**



# Gooseneck Punches

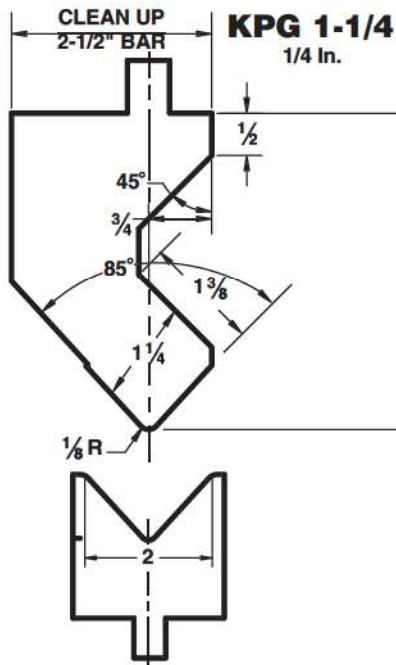

1/4 IN  
**KD 2**

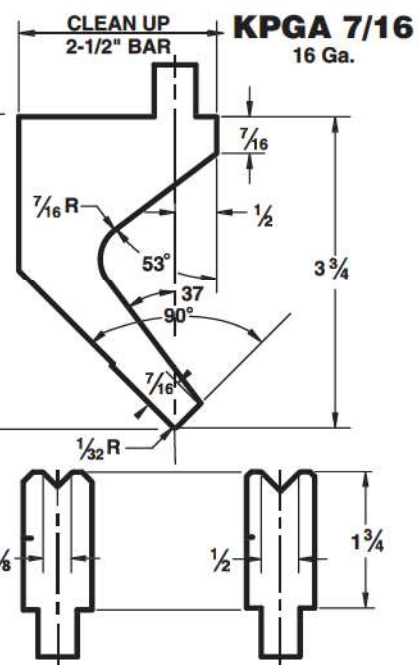

18 Ga.  
**KD 3/8**

16 Ga.  
**KD 1/2**

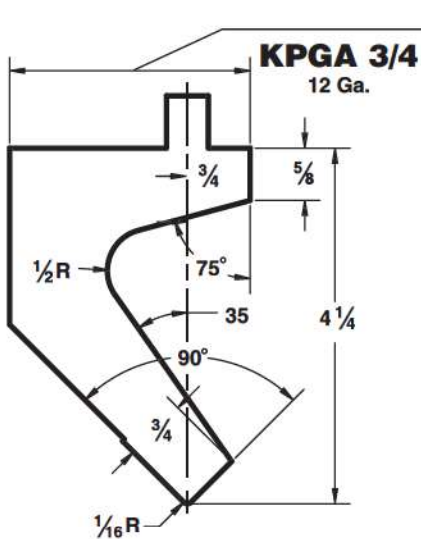

13 Ga.  
**KD 3/4**

12 Ga.  
**KD 7/8**

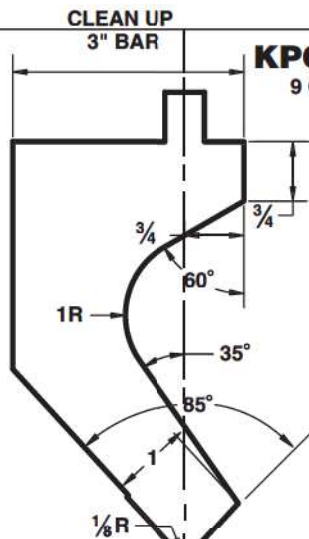

9 Ga.  
**KD 1-1/4**

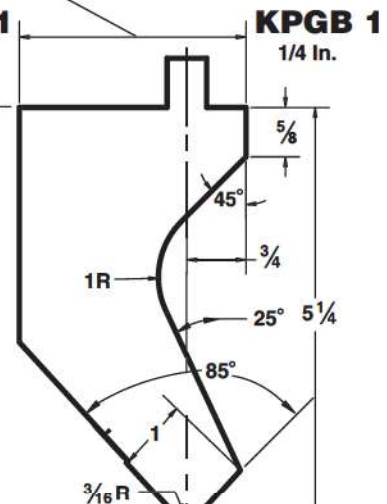

1/4 IN  
**KD 2**

# Acute Punches and Dies

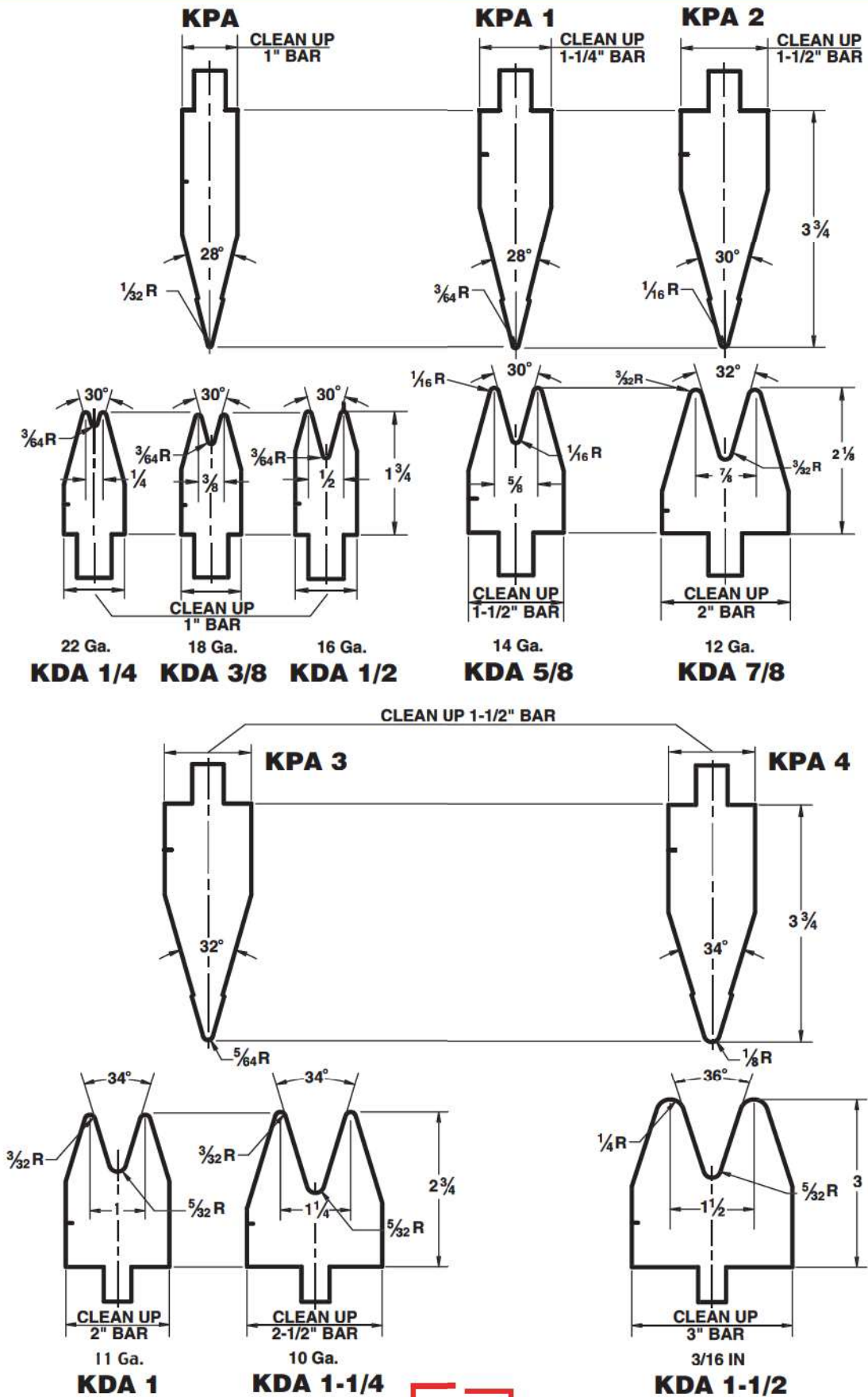

# Offset Dies

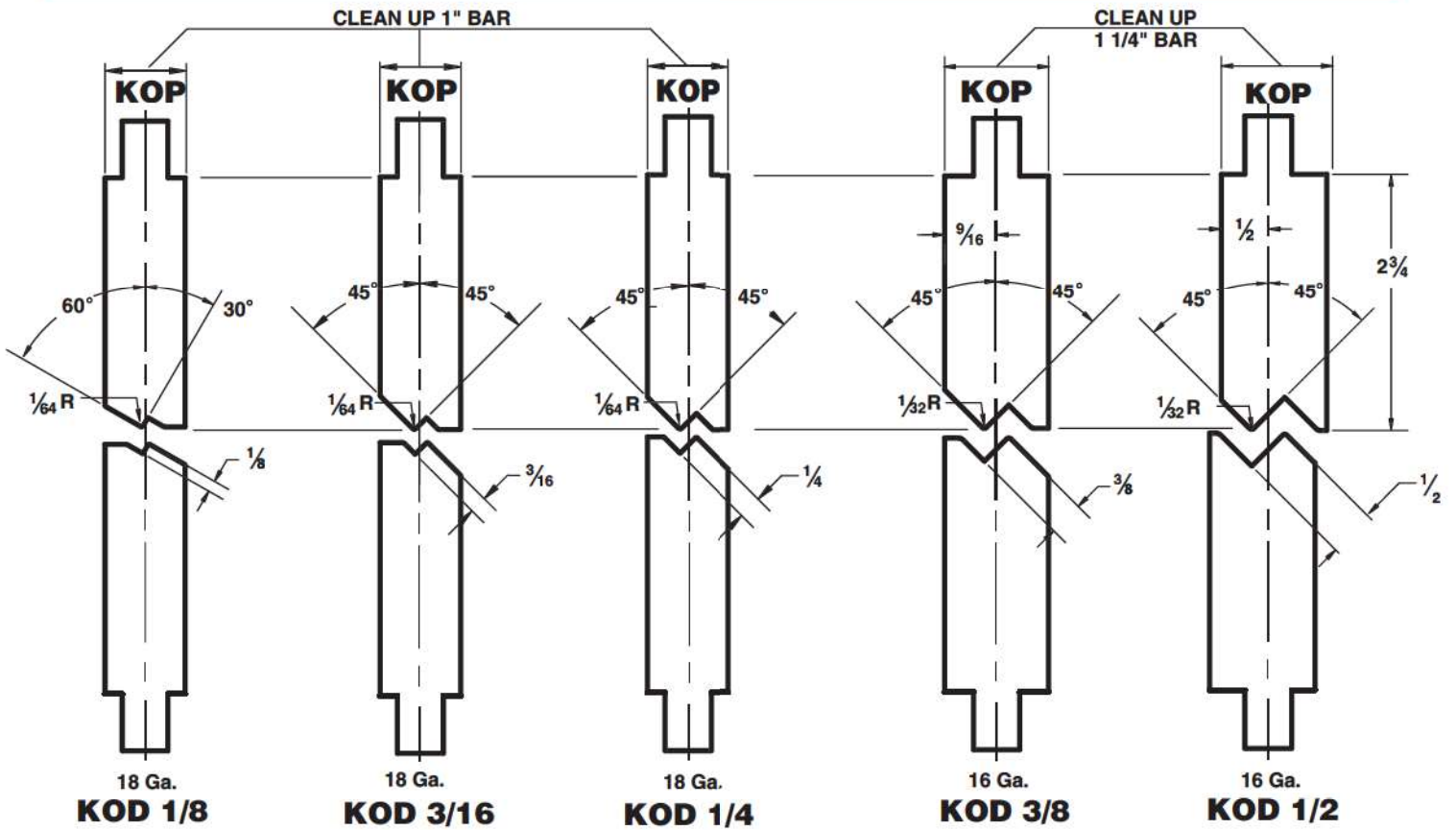

Any die can be relieved as shown by dashed line to clear a preformed offset.

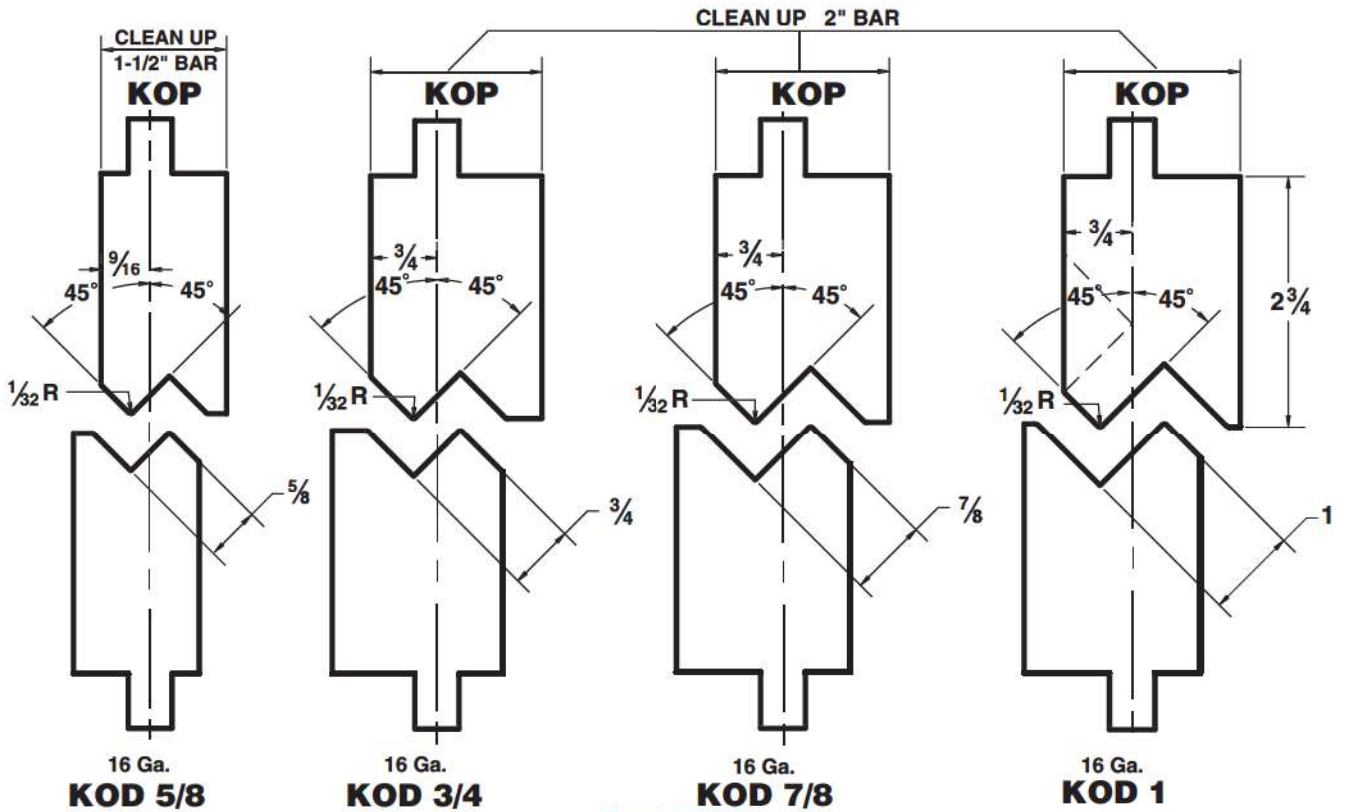



# Flattening Dies

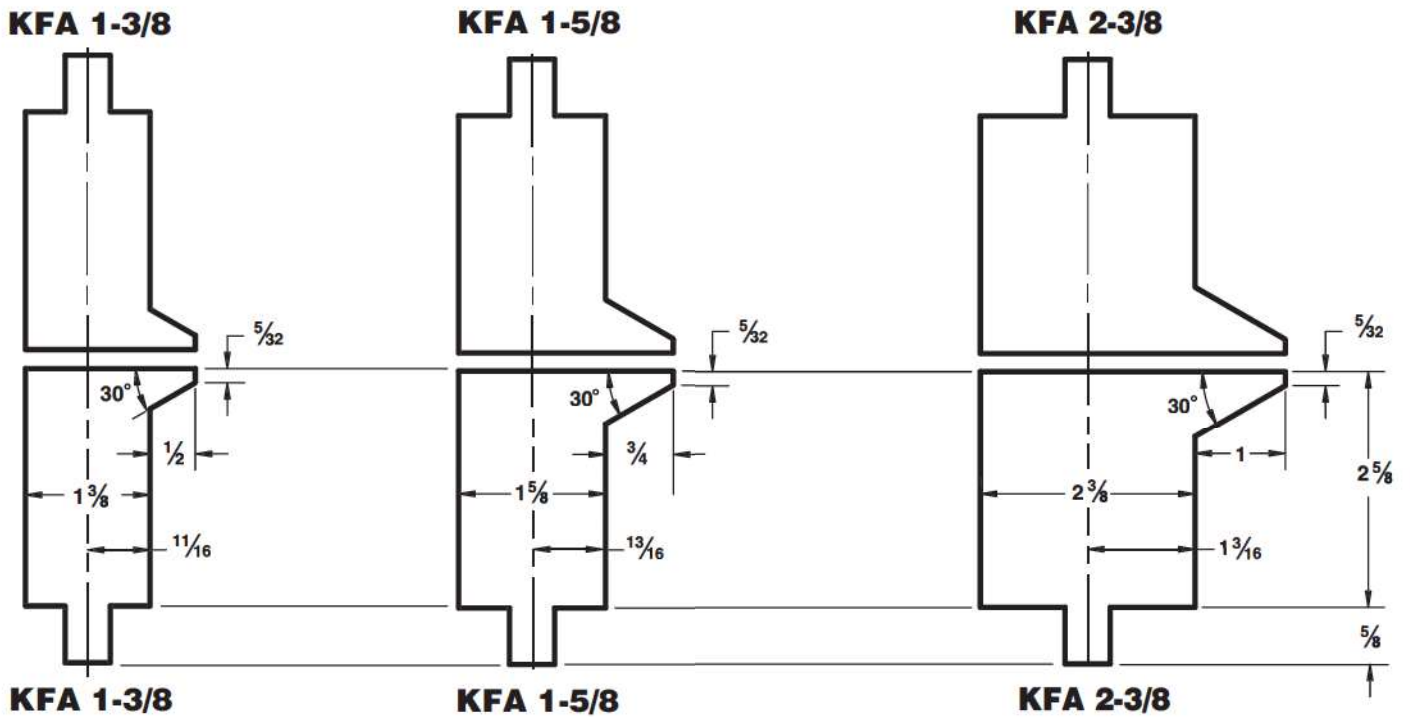
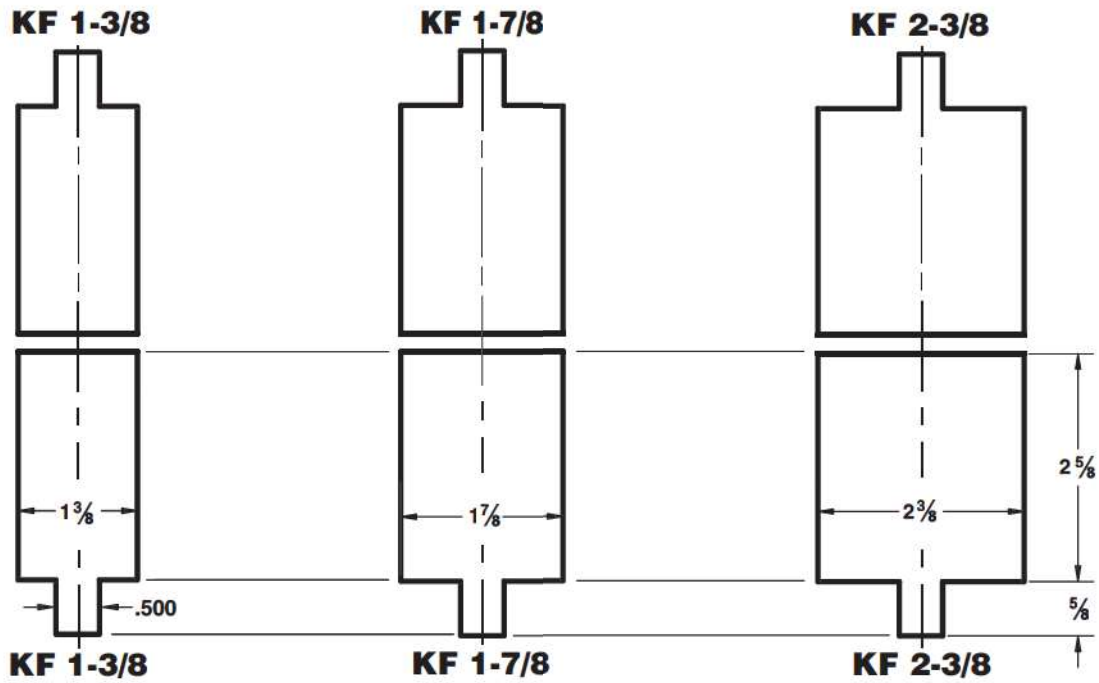

# Adjustable Bottom Dies

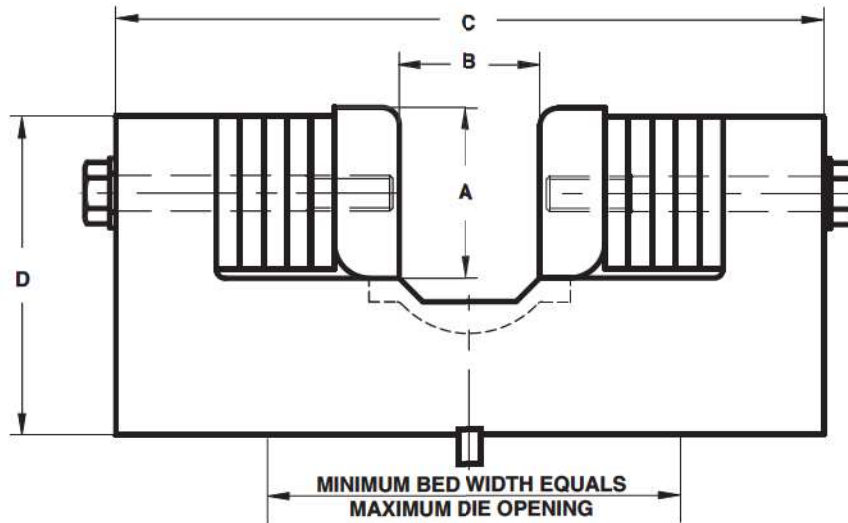

Die #	A	B	C	D
KAD3	1-1/2	1/4-3	7	3
KAD5	2-3/8	1/2-5	11	5
KAD6	3	1-6	13	6
KAD7	3-1/4	2-7	14	6-1/2
KAD8	3-5/8	3-8	15	6-3/4
KAD10	3-3/8	5-10	17-1/2	7
KAD12	4-3/8	7-12	22	9-1/2

## COMBINATION FOUR WAY DIE HOLDERS

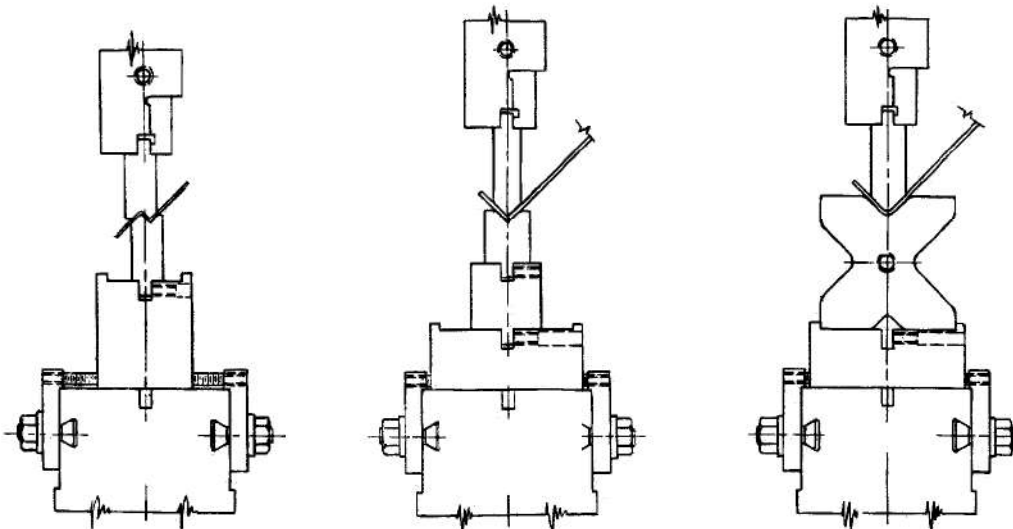

# Box Forming Punches

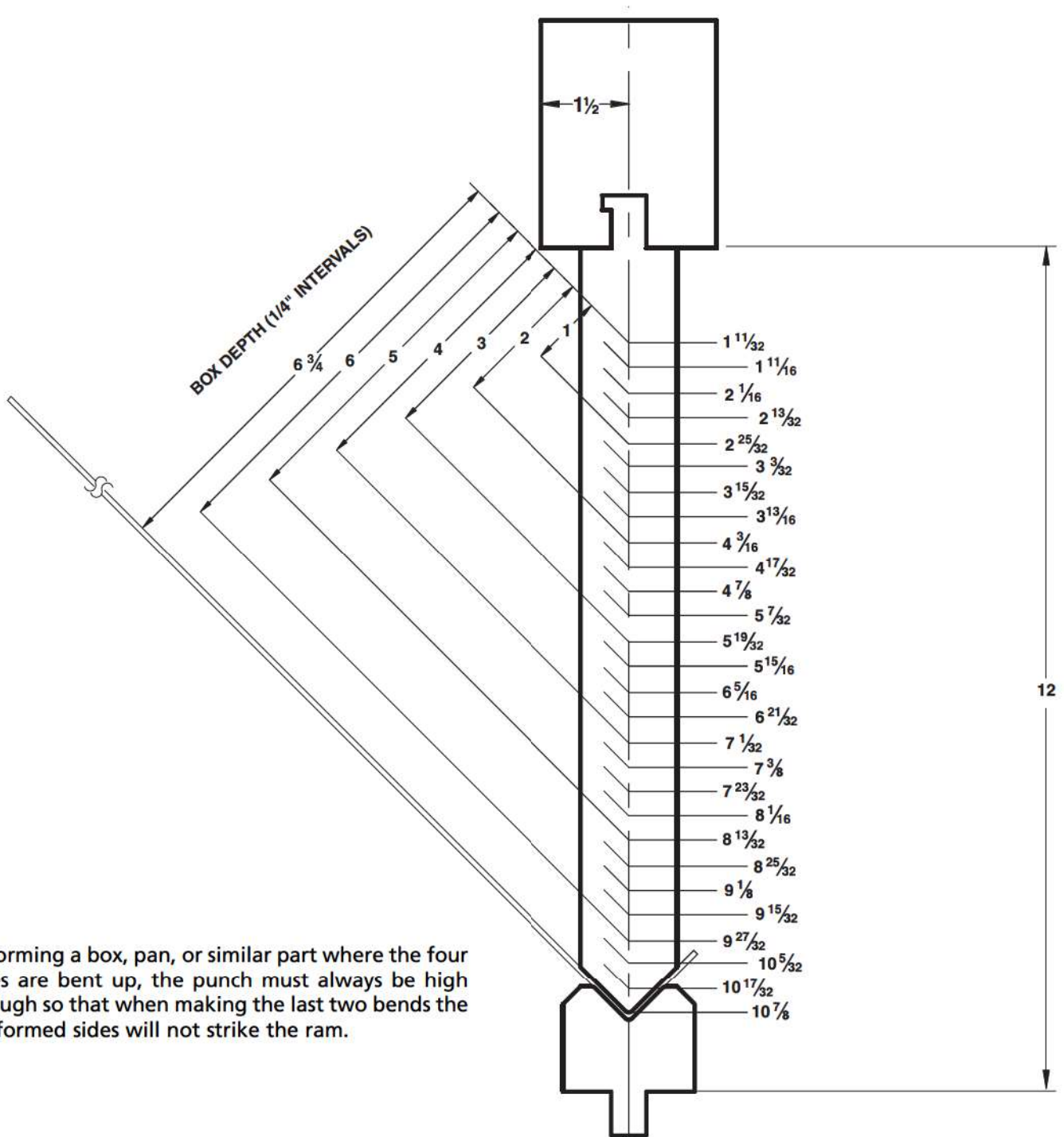

In forming a box, pan, or similar part where the four sides are bent up, the punch must always be high enough so that when making the last two bends the preformed sides will not strike the ram.



# 60-30 Box Forming Punch

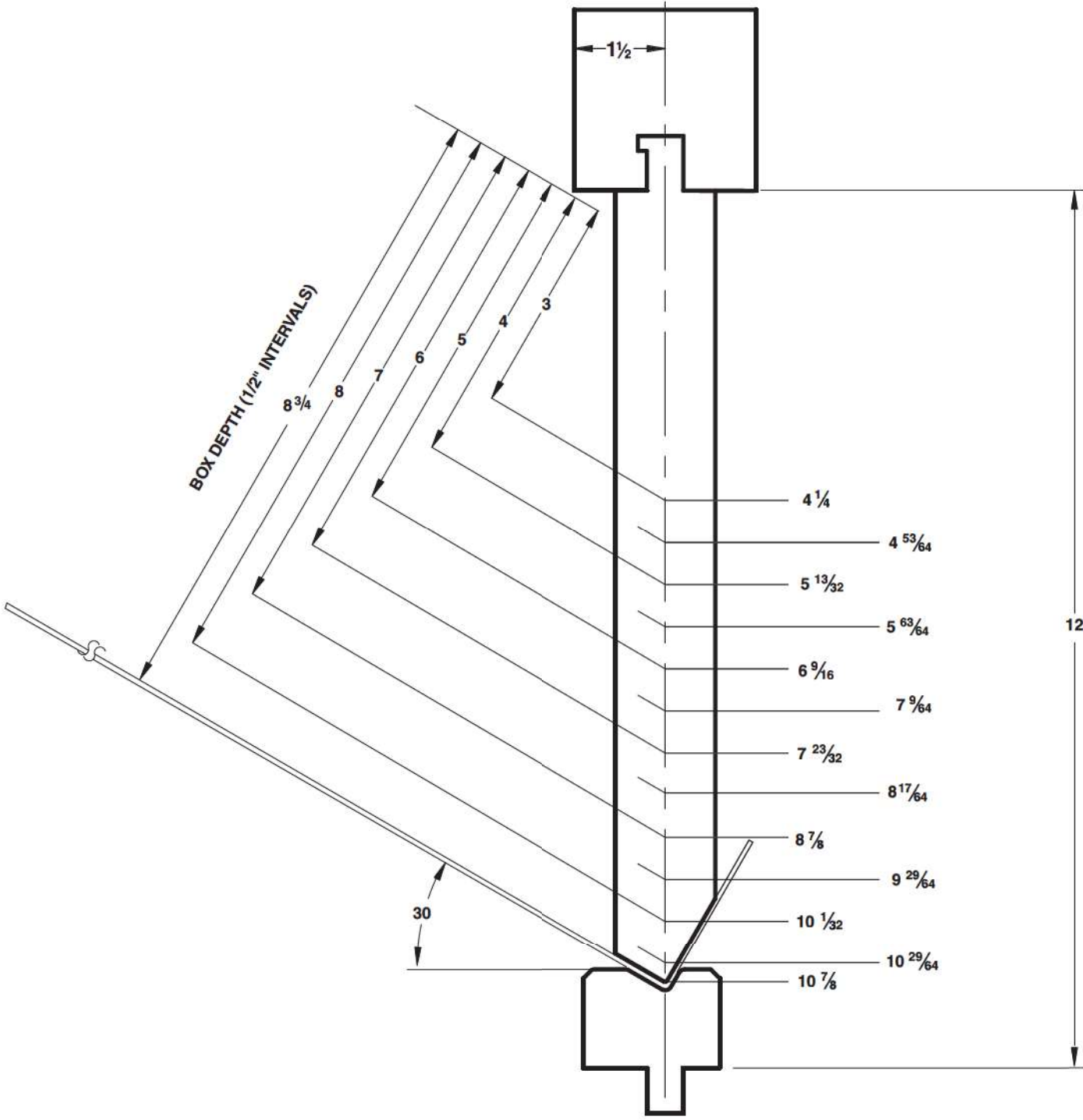

# Three and Four Way Dies

When the need to replace several single Vee dies is found, four female die openings can be formed from a single bar. The general use of a four way die is for straight bending operations. They can also be used as die holders or for radius forming.

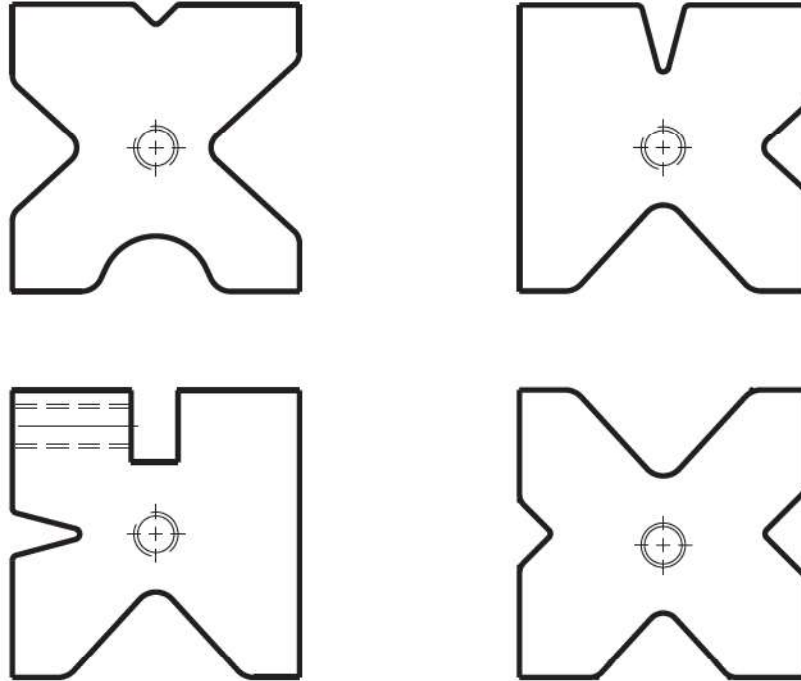

Die No.	3 Way Die Opening Sizes			Block Size	Die No.	4 Way Die Opening Sizes			
K3W22	.50	.75	1.00	2.25	K4W22	.50	.75	1.00	1.25
K3W27	.75	1.125	1.50	2.75	K4W27	.625	.875	1.125	1.50
K3W32	1.00	1.50	2.00	3.25	K4W32	.75	1.00	1.50	2.00
K3W37	1.125	2.00	2.50	3.75	K4W37	.875	1.125	2.00	2.50
K3W42	1.00	2.00	3.00	4.25	K4W42	1.00	1.50	2.00	3.00
K3W47	1.25	2.00	3.00	4.75	K4W47	1.00	1.25	2.50	3.00
K3W52	1.50	2.50	3.50	5.25	K4W52	1.00	2.00	3.00	4.00
K3W57	1.50	2.50	4.00	5.75	K4W57	1.25	2.00	3.00	4.00
K3W67	1.50	3.00	5.00	6.75	K4W67	2.00	3.00	4.00	5.00
K3W77	2.00	3.50	6.00	7.75	K4W77	2.00	3.00	4.00	6.00
K3W10	2.50	4.00	8.00	10.00	K4W10	2.00	4.00	6.00	8.00
K3W12	3.00	6.00	10.00	12.00	K4W12	3.00	4.00	6.00	10.00

Above opening sizes are recommended for the block size shown. You may request other openings provided that they are appropriate for the block size you requested.

All openings shown above are at 85° for sizes one inch and greater. Smaller openings are at 90°

All three and four way die are manufactured with end holes tapped for easy rotation.

# Die Holders Ram Adapters

## DIE HOLDER

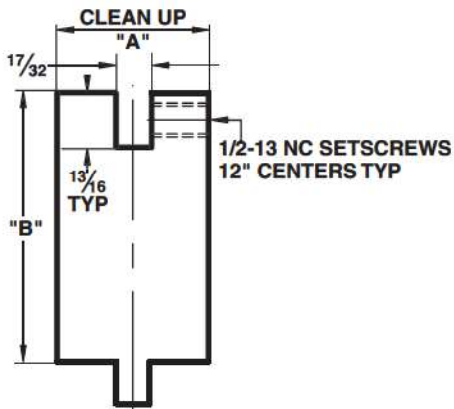

OPTIONAL "D" BURNOUTS FOR HOLDERS W/4" AND GREATER NET HEIGHT

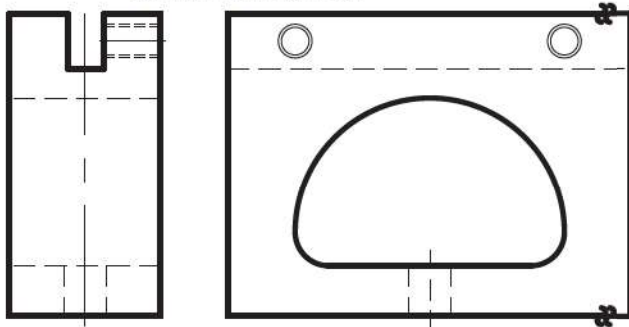

Holder #	A (width)	B (net height)
RB1	2	1.5
RB2	2	2
RB3	2	2.5
RB4	2	3
RB5	2	3.5
RB6	2	4
RB7	3	1.5
RB8	3	2
RB9	3	3
RB10	3	3.5
RB11	3	4
RB12	3	5
RB13	3.5	3.5
RB14	3.5	4
RB15	3.5	5
RB16	4	4
RB17	4	5

## RAM ADAPTERS

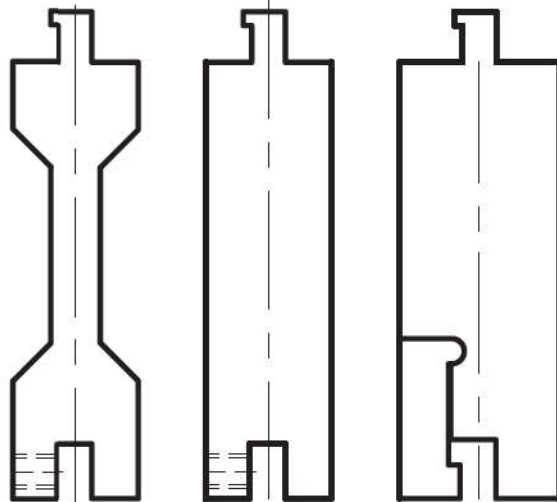

KRA 30

KRA 40

KRA 50

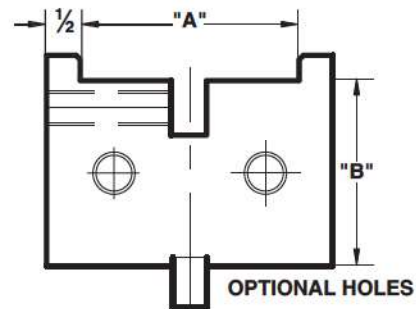

FOUR WAY HOLDER

Holder #	A	B	Holder #	A	B
UDH01	2.25	3.5	UDH11	4.75	3.5
UDH02	2.25	5	UDH12	4.75	5
UDH03	2.75	3.5	UDH13	5.25	3.5
UDH04	2.75	5	UDH14	5.25	5
UDH05	3.25	3.5	UDH15	5.75	3.5
UDH06	3.25	5	UDH16	5.75	5
UDH07	3.75	3.5	UDH17	6.75	3.5
UDH08	3.75	5	UDH18	6.75	5
UDH09	4.25	3.5	UDH19	7.75	3.5
UDH10	4.25	5	UDH20	7.75	5



# Special Offset Die Sets

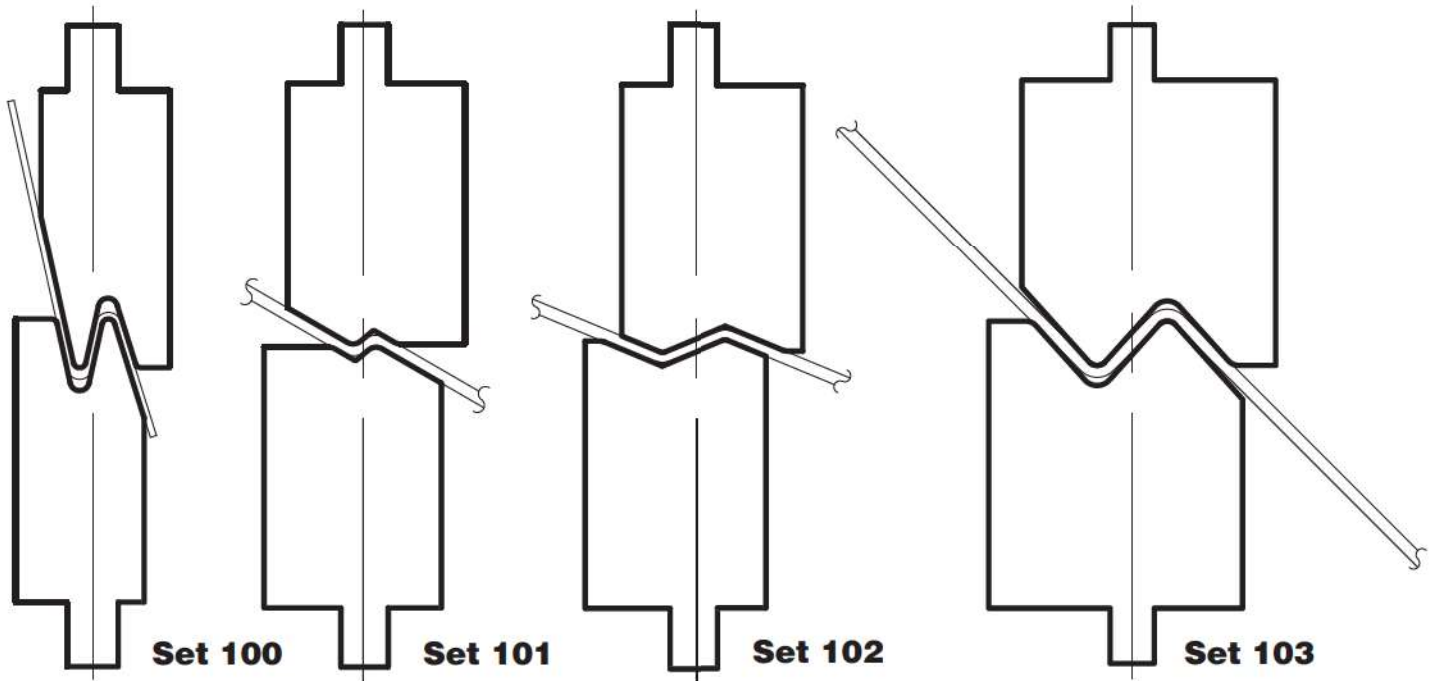

Die set 100 is designed for forming acute angle offsets on 18 ga. and lighter material. Set 101 is used for air forming open angle offset. Set 102 is for bottom bending shallow open angle offsets in material up to 16 ga. in thickness, Die set 103 will air form a 90° when available tonnage eliminates considering bottom forming dies.

Die sets 104 and 105 are used for forming material thickness offsets close to the end of the sheet. Die set 106 is required when the flanges are shorter than the offset being formed; gauging is built into the set to ensure consistent and accurate parts.

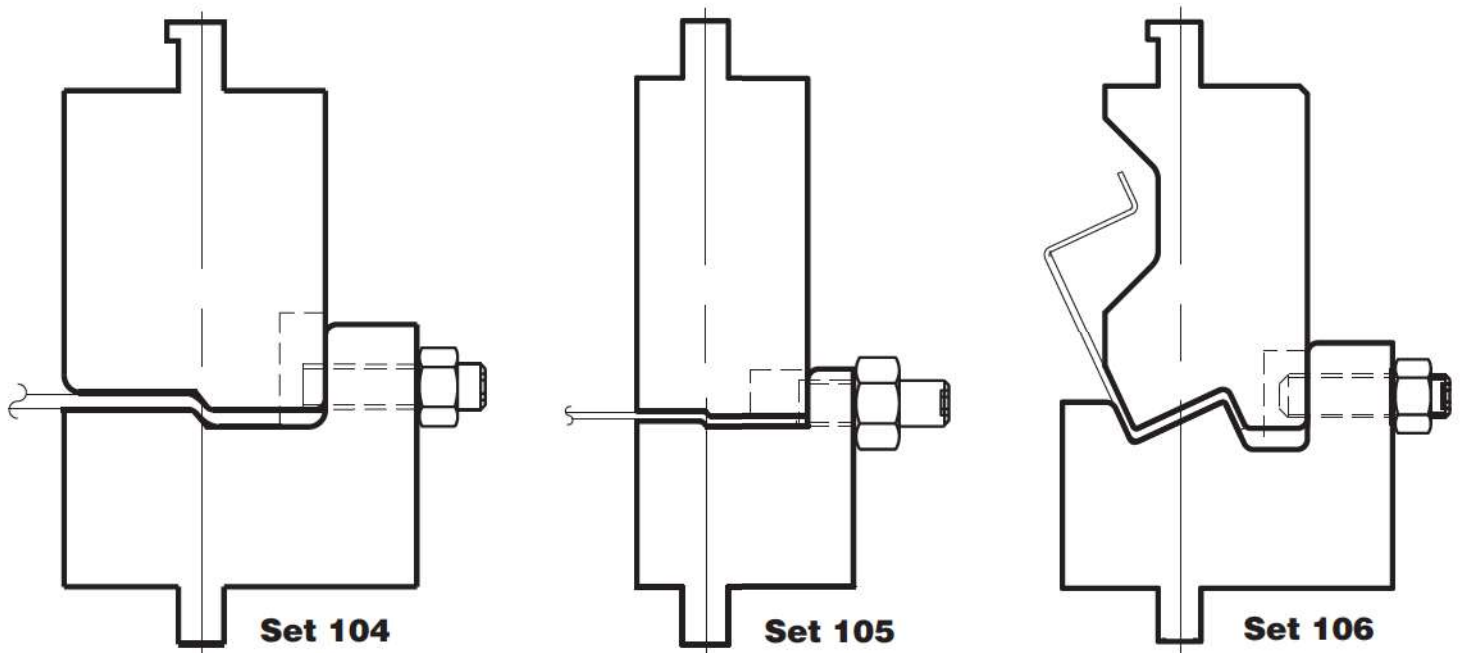

# Hemming Dies



**Set 107**

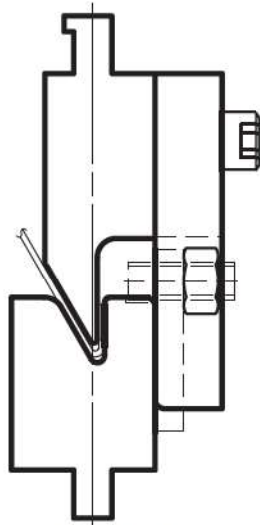

**Set 108**

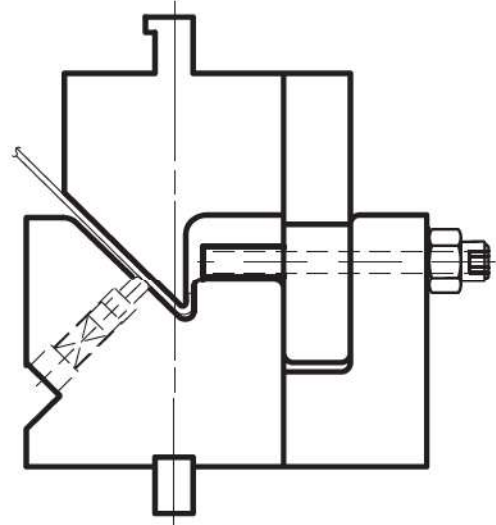

**Set 109**

107 is an inexpensive hemming die set for forming teardrop or open hems on 20 ga. and lighter material. It offers the advantage of performing the entire forming in a single set of tooling. The length of the foldover cannot exceed 2 inches. A slight bow in longer sheets may appear due to the uneven angles of the punch and die. The second or closing operation requires that the sheet be held high enough in

the die to ensure that the point of the punch passes over the edge of the first bend. 108 is modified with a leader for materials up to 16 ga. mild steel. 109 forms an open or teardrop hem in two operations on 14 ga. and lighter material. It is designed to reduce whip up and bowing in the center of longer sheets. It is limited to hems where the foldover is 3/4 in. or less.

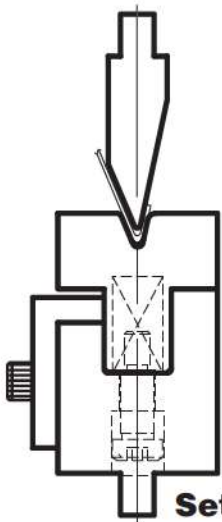

**Set 110**

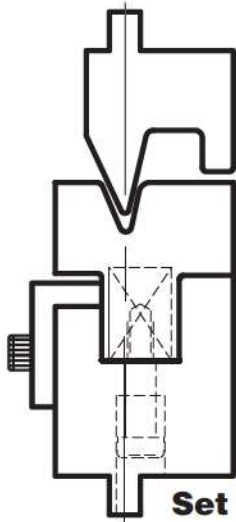

**Set 111**

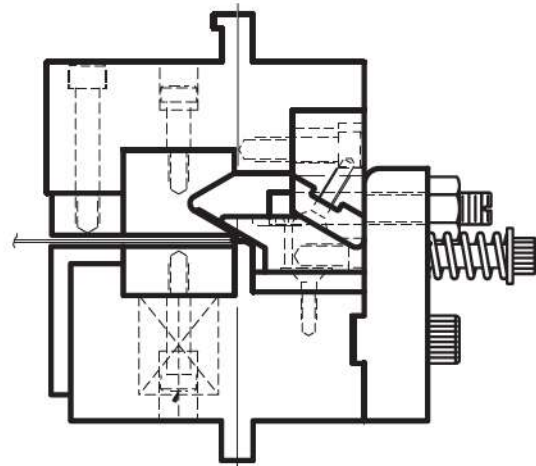

**Set 112**

Die set 110 is our standard hemming die for 18 ga. material and lighter. It produces a full range of open to closed hems by shimming under the adjustable angle of the lower section. 111 has been modified to handle up to 14 ga. material by adding a back heel to the top section of the die set.

Die set 112 is a high production die set that is designed to eliminate sheet whip up and minimize poorly formed parts due to operator error. This set is designed to handle 18 ga. and lighter material.

# Standing Seam Dies

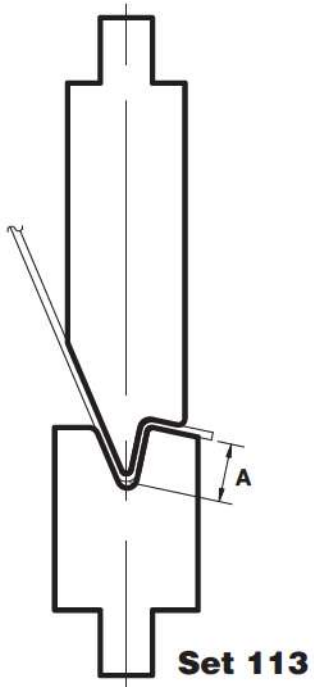

Die set 113 is used in conjunction with flattening dies to form a standing seam in two operations. This set forms the acute angle offset and the flattening die close the angle. Die set 114 is used to perform both the acute angle offset and the closing operation in the same set. When ordering these die sets please specify the "A" dimension.

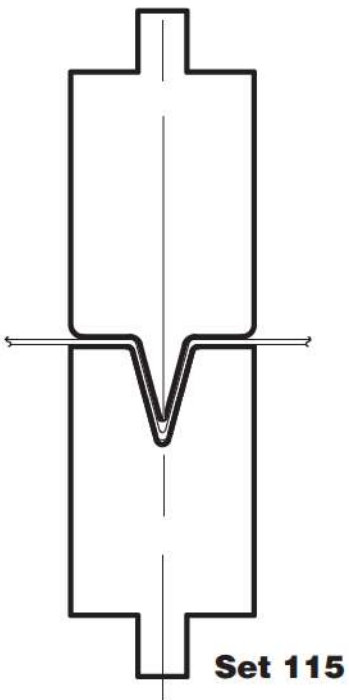
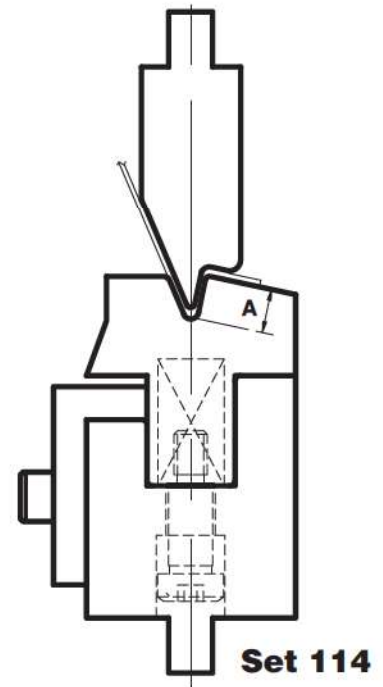

Die sets 115 and 116 are used together in a two step operation when forming a seam in the middle of the sheet. Typically, these sets will have matched shut heights so that the operator can perform both steps in the same press brake.

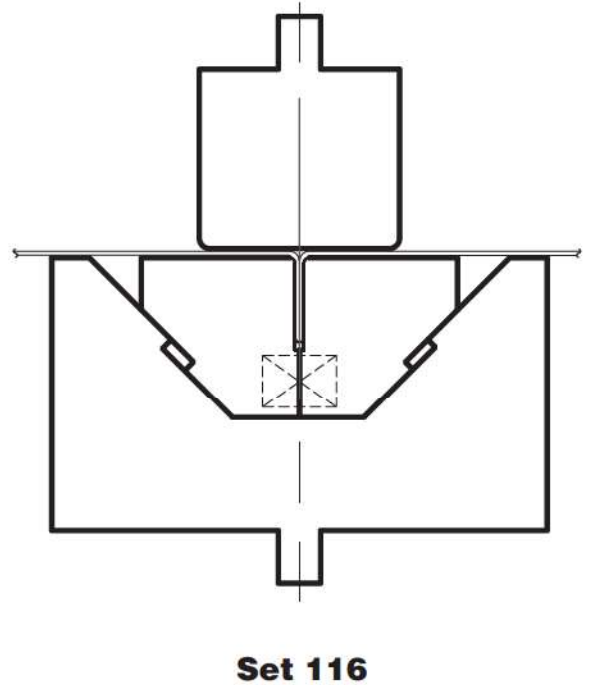



# Radius Die Sets

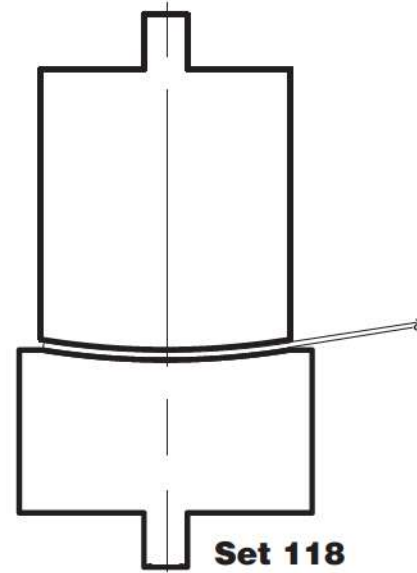
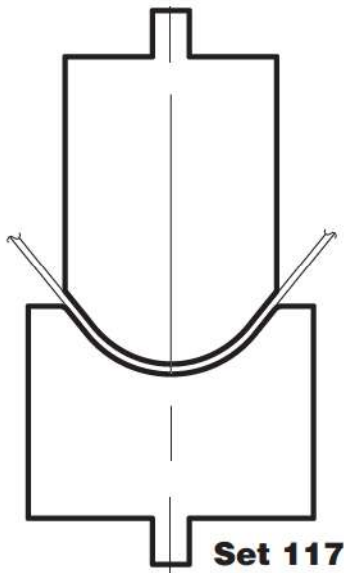

Die set 117 is used for bottom forming a given radius for a specific material. It is designed with compensation for spring back of material. Die set 118 is designed for forming a large radius in multiple hits. It may also be used for forming a radius on the edge of the sheet prior to a rolling operation.

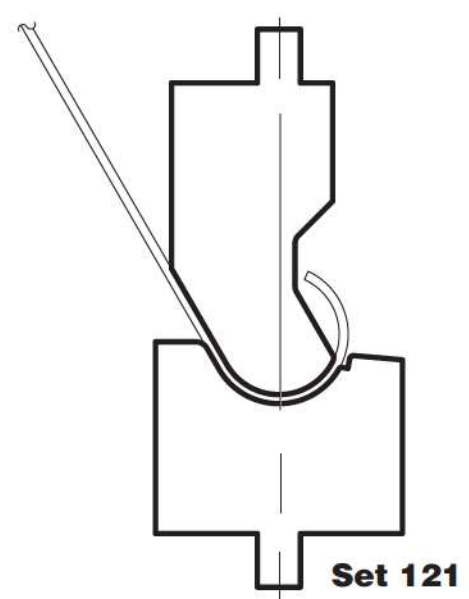
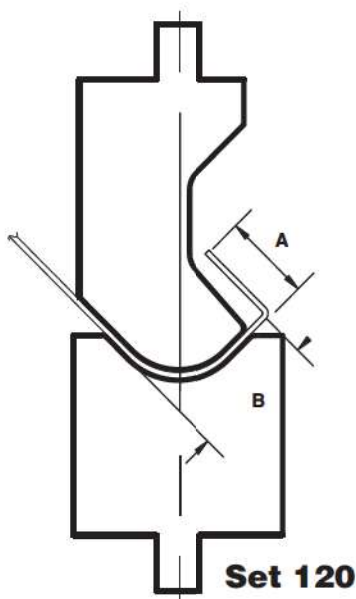
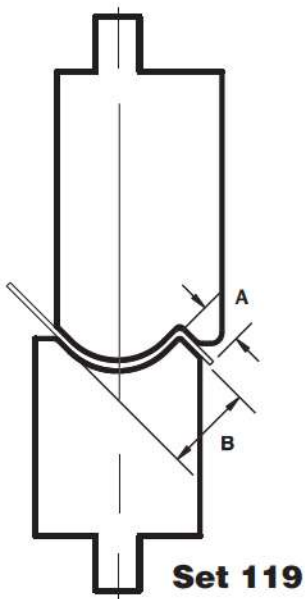

Die set 119 is used when forming a radius with an outside flange in one hit if spring back of material is not too great. When ordering, please specify the "A" and "B" dimensions.

Die set 120 and 121 have gooseneck style radii punches. Set 120 is used to form a radius with a preformed return flange. Set 121 is used to form a sanitary curl common in the restaurant industry and forms 200° of radius in two hits.

# Curling Dies

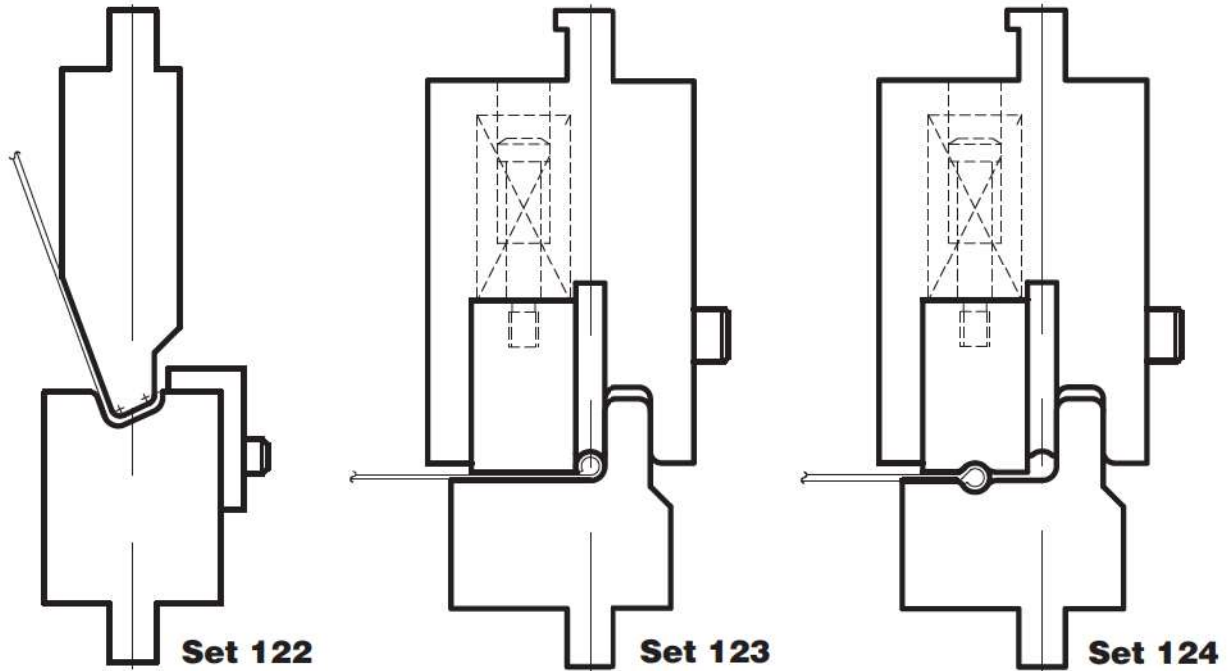

Die set 122 and 123 or 124 are used in combination to form the smallest curls possible provided that the inside diameter is at least three times the material thickness. Die set 123 is used when an off center curl is desired and required two hits; and 124 is used for an on center curl in three hits. When forming heavier gauge material, a tool steel insert can be used.

Die set 125 and 126 are used to minimize whip up. Die set 125 forms an off center curl in three hits, and die set 126 forms an on center curl in four hits. Both sets can be designed to accommodate material up to 16 gauge and curls between 1/4" and 3/4" inside diameter.

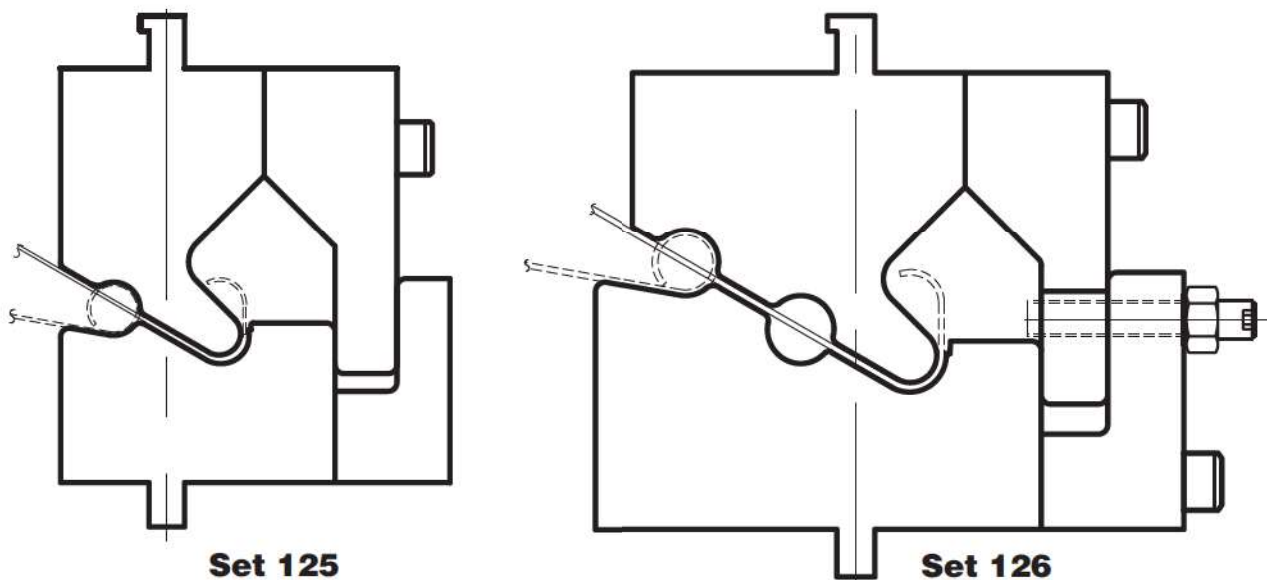

# Channel Die Sets

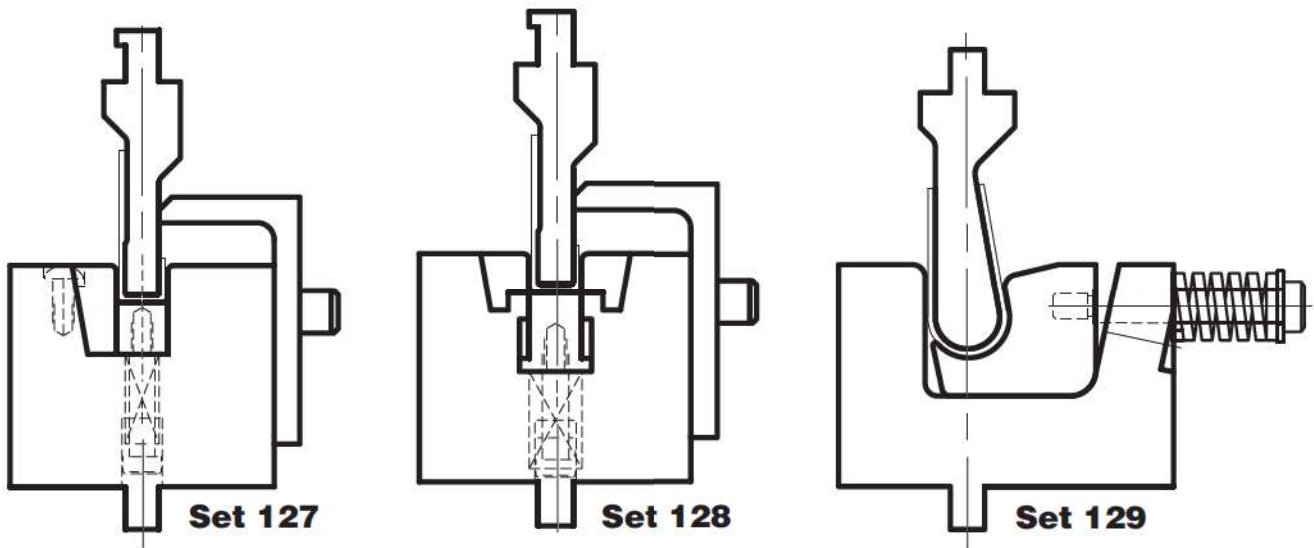

Die sets 127 and 128 are used to form channels with an inside web of  $3/4$ " or less. A stripper is provided to remove the part. Die set 128 is used where flatness of the web is critical. Die set 129 is used to form a "U" shaped channel. It has a built in allowance for spring back due to the overbending caused by the rocker insert in the bottom die. Applications for this die set are limited by material type and thickness.

Die set 130 is designed to form a channel where the inside radii may cause springback due to being  $1-1/2$  to 2 times material thickness or greater. Rocker inserts overform the channel to compensate for this. The part is easily removed as it springs open to the desired shape.

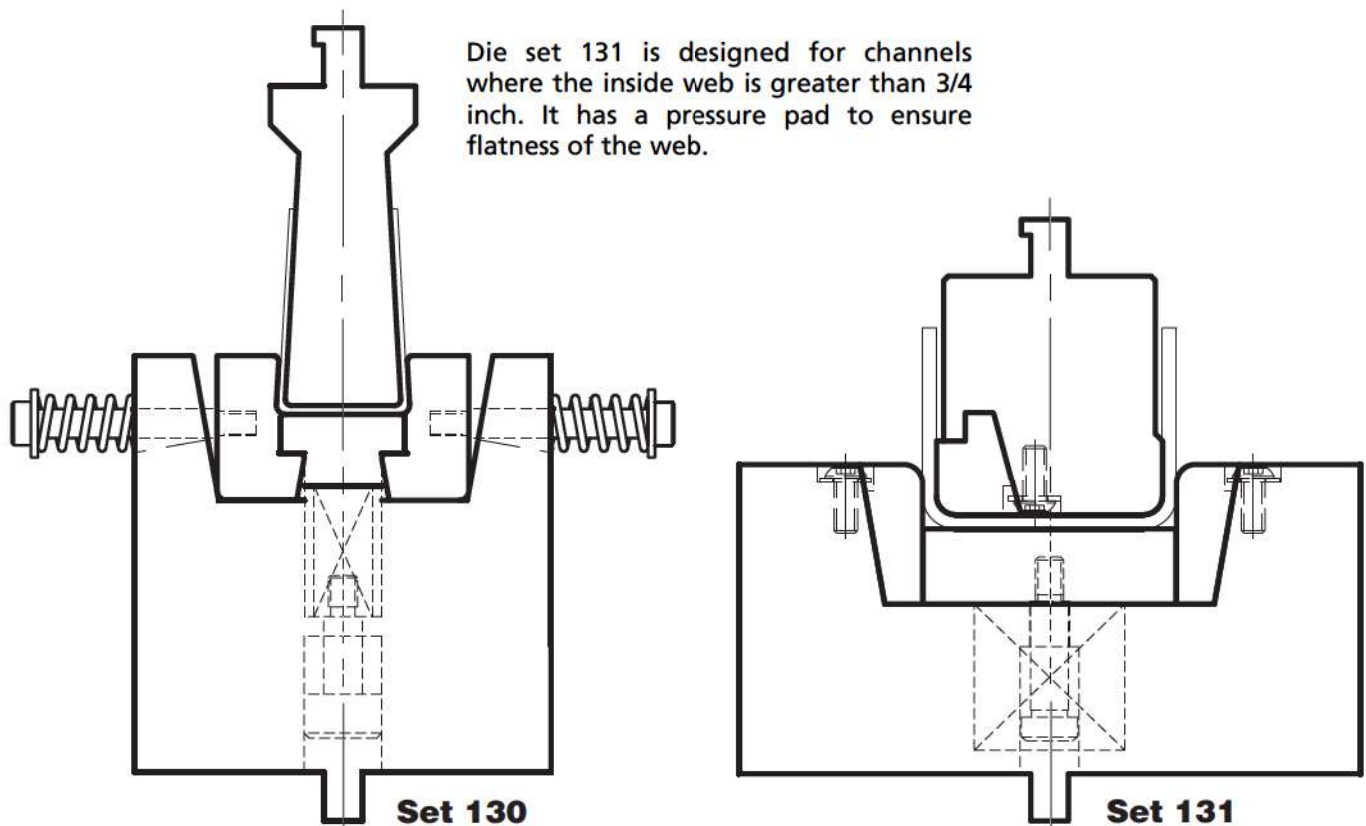

Die set 131 is designed for channels where the inside web is greater than  $3/4$  inch. It has a pressure pad to ensure flatness of the web.



# Channel Die Sets

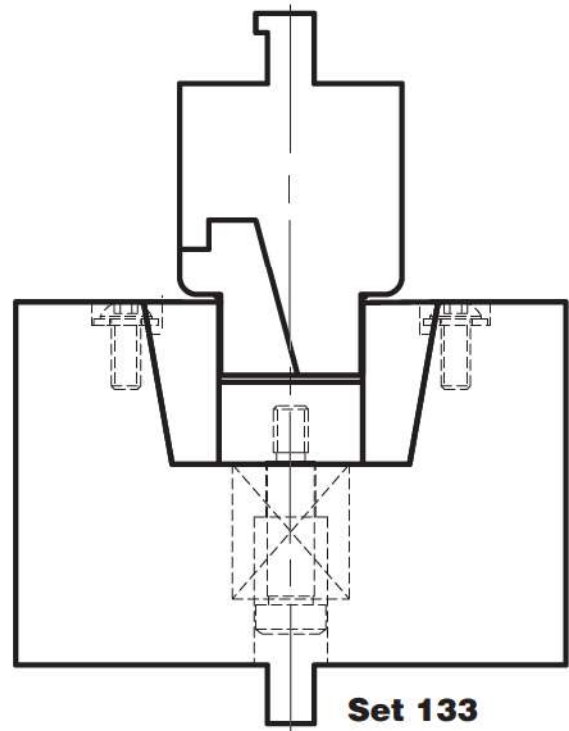
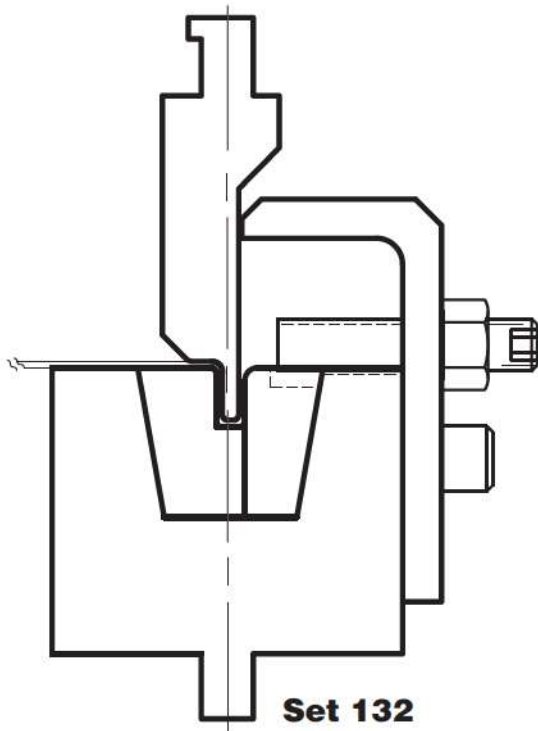

Die set 132 is made to form a semi hat channel at the edge of the sheet. This die set includes a release wedge and stripper to ensure easy part removal.

Die sets 133 and 134 are used to form hat channels. 133 forms four 90 degree bends in one hit and includes a pressure pad to ensure flatness of the set and release wedges in the punch and die to allow for easy part removal. Die set 134 forms an open hat channel in one hit.

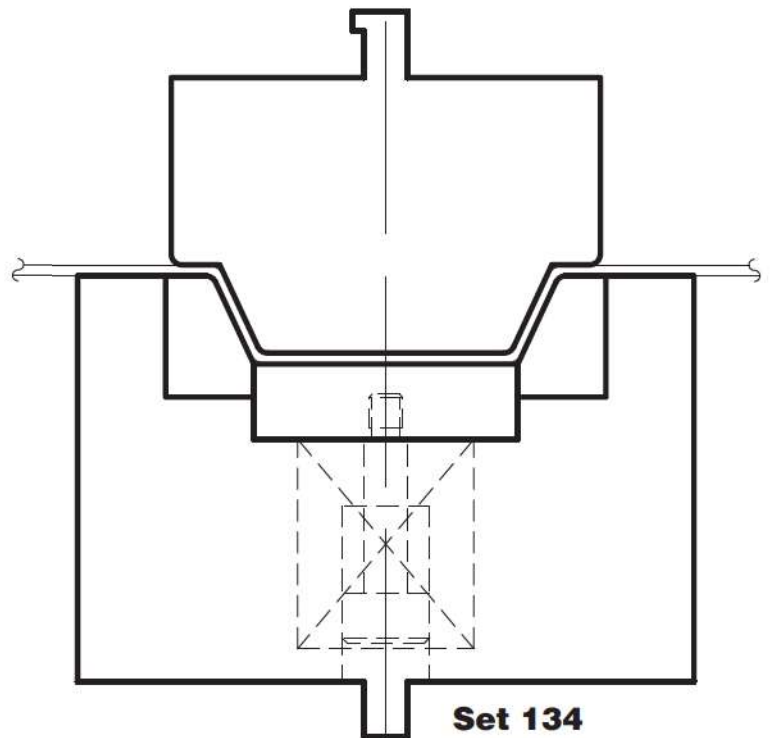

# Rib Die Sets

Die sets 135, 136 and 137 represent tooling to form standard stiffening ribs on light gauge material.

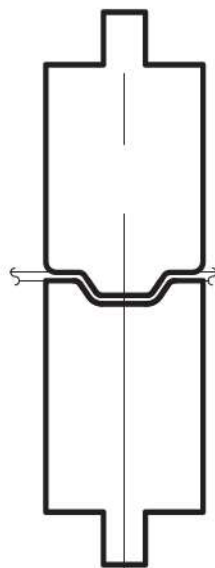

**Set 135**

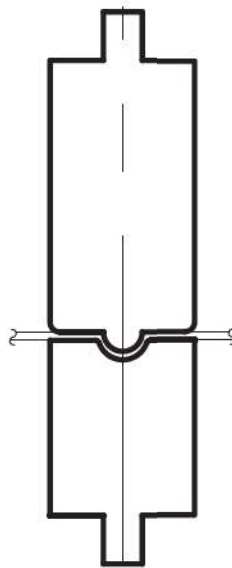

**Set 136**

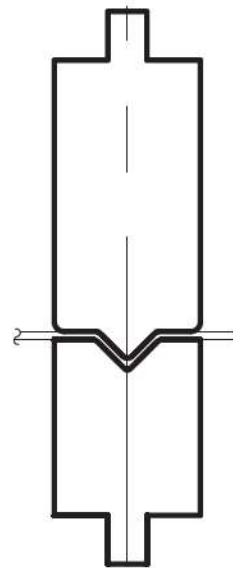

**Set 137**

# Corrugating Dies

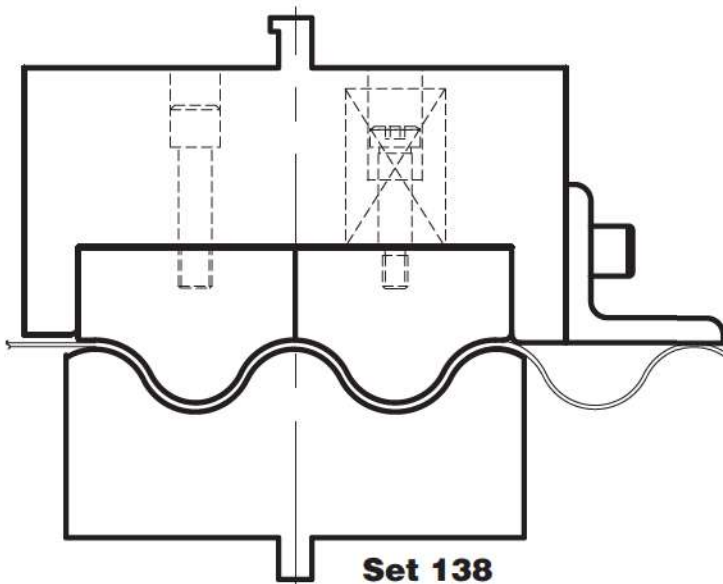

**Set 138**

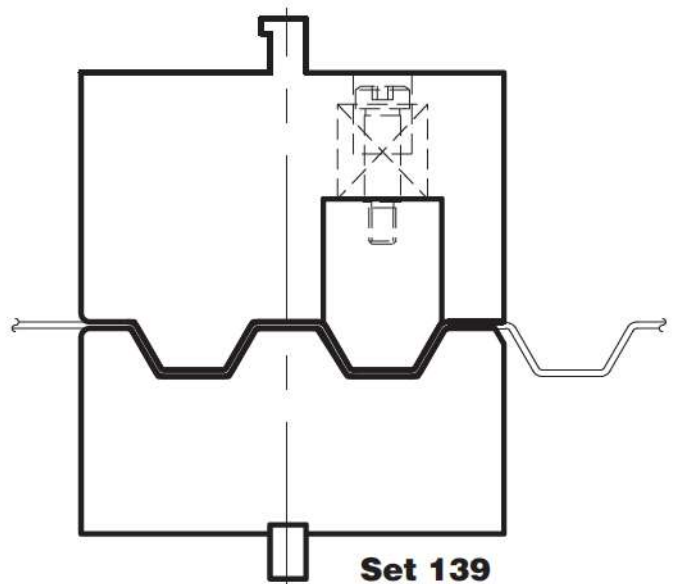

**Set 139**

138 and 139 are examples of high production corrugating die sets. These sets are designed for forming a continuous corrugation while maintaining accurate and consistent shapes. This is accomplished through the use of spring loaded pressure pads which trap the previously formed section of the corrugation, making these sets self gauging.

# Wiping Dies

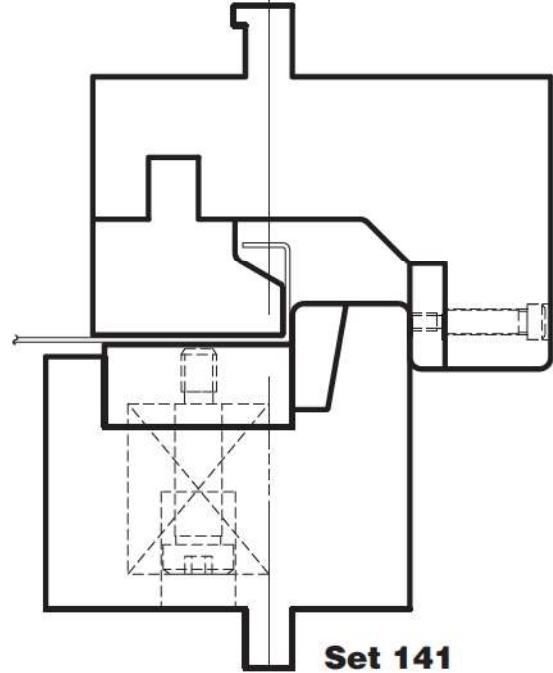
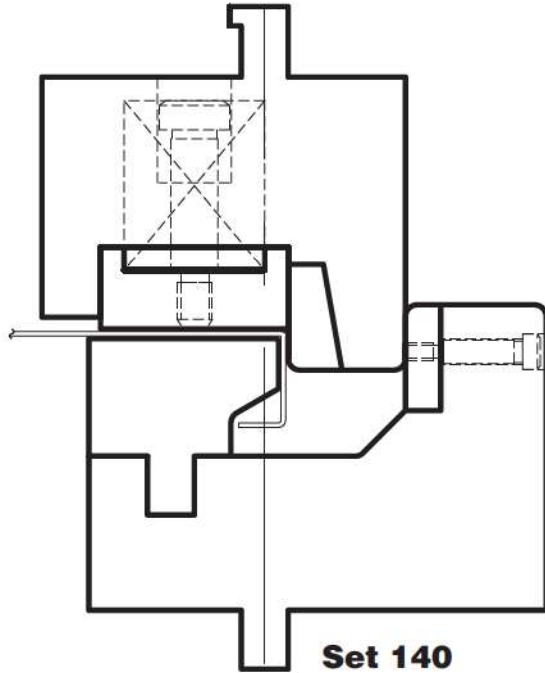

# Rocker Dies

Wiping dies are designed for lighter gauge material where whip up must be eliminated. They are used to form flanges or edge channels at the end of the sheet. Die sets 140 and 141 are designed for 18 gauge and lighter material. These die sets can be adjusted to account for variations in material thickness by shimming the insert at the back of the die.

Rocker dies are used for applications where clearance problems make other die sets impractical. They are limited to 16 ga. and lighter material. Rocker dies can perform a variety of multiple bend shapes in one hit such as table edges -Set 142 and edge channels - Set 143

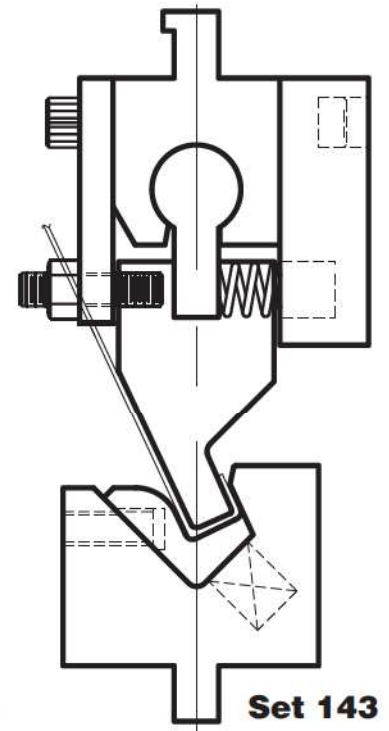
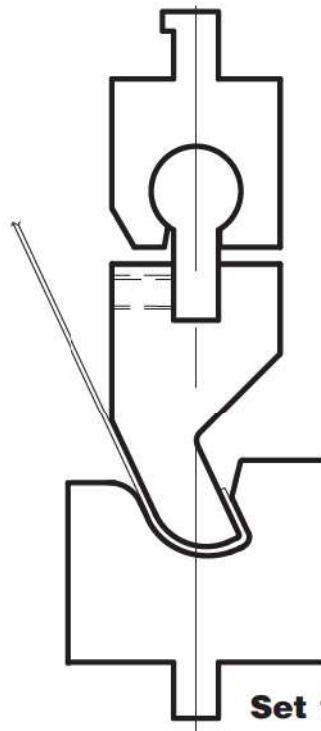



# Special Purpose Die Sets

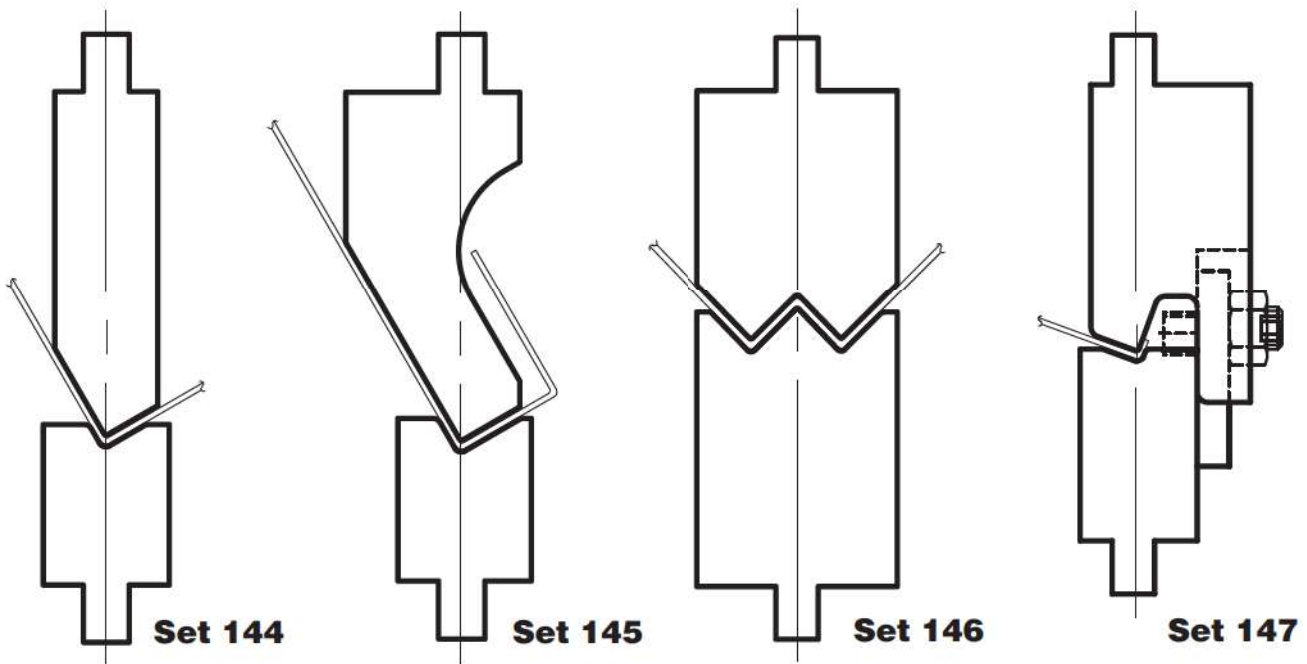

Die sets 144 and 145 are tipped angle sets that are used to form deep channels in two hits. They are used for up to 12 ga. material. They may cause marking and bowing in longer length parts; and at heavier gauges, put extra wear on the ram of the press brake.

Die set 146 makes a "W" shape in one stroke. A heel may be added for heavier gauge material. Die set 147 is used when the flange length is too short to be safely formed with standard tooling. This set has built in gauging and is heeled to prevent spreading.

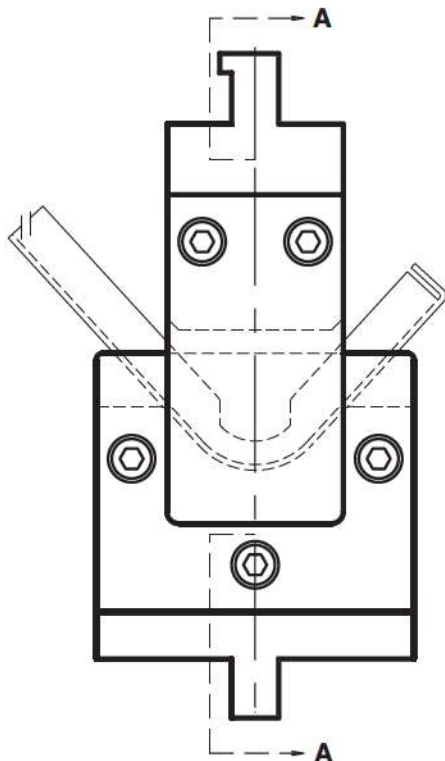

Die set 148 is used to form a radius on a part that has preformed up-turned flanges on the ends. The bottom die has clapper plates to hold the flanges and help to minimize flange deformation while forming the radius.

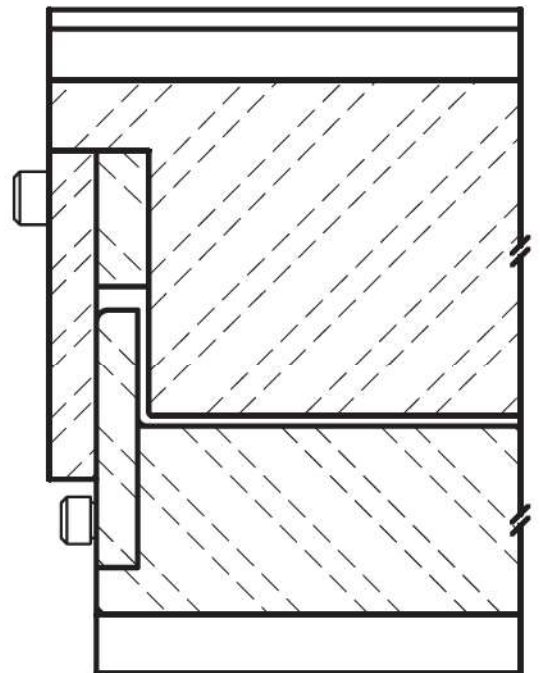

# European Tooling

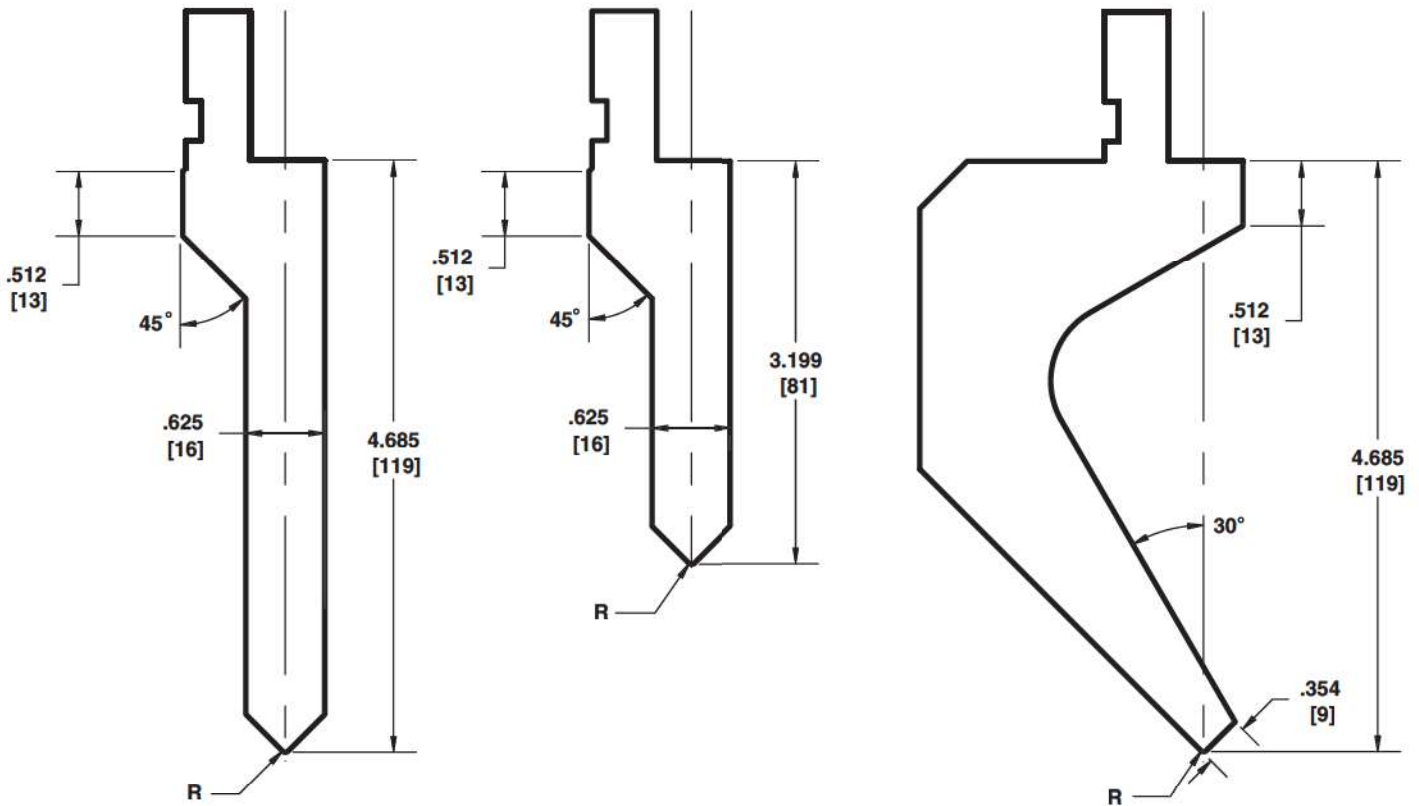

**Straight Punch @ 88 or 90 Degrees**

Tool No.	Height	Radius
KPE1	4.685 (119)	.016 (.4)
KPE2	3.189 (81)	.016 (.4)
KPE3	4.685 (119)	.031 (.8)
KPE4	3.189 (81)	.031 (.8)

**Gooseneck Punch @ 88 or 90 Degrees**

Tool No.	Radius
KPGE1	.016 (.4)
KPGE2	.031 (.8)

Kazmier Tooling, Incorporated offers an inexpensive alternative to precision ground European style tooling. The tooling is available in standard lengths and sectionalized lengths. Additionally, you can order the tooling at specific lengths at 12 feet or 3,000 millimeters. Our tooling is precision planed to +/- .002 in. - .05 mm. on critical dimensions.

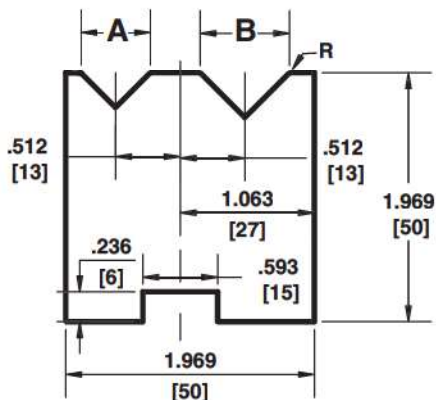

**Double Vee Dies @ 88 or 90 Degrees Quick Change**

Die No.	A	B	R
KDE1	.551 (14)	.709 (18)	.016 (.4)
KDE2	.472 (12)	.787 (20)	.016 (.4)
KDE3	.630 (16)	.984 (25)	.031 (.8)
KDE4	.236 (6)	.394 (10)	.063 (1.6)
KDE5	.472 (12)	.787 (20)	.063 (1.6)

# European Tooling

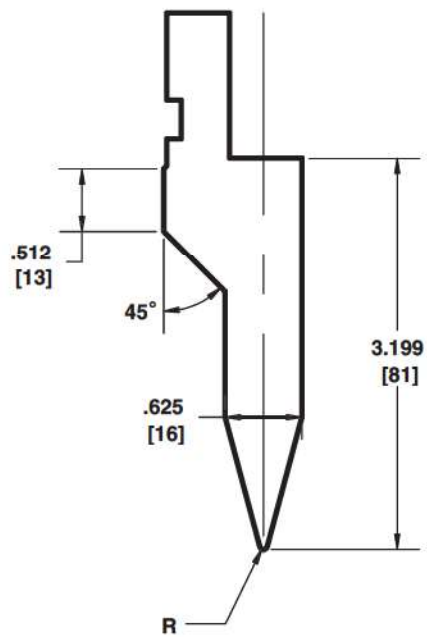
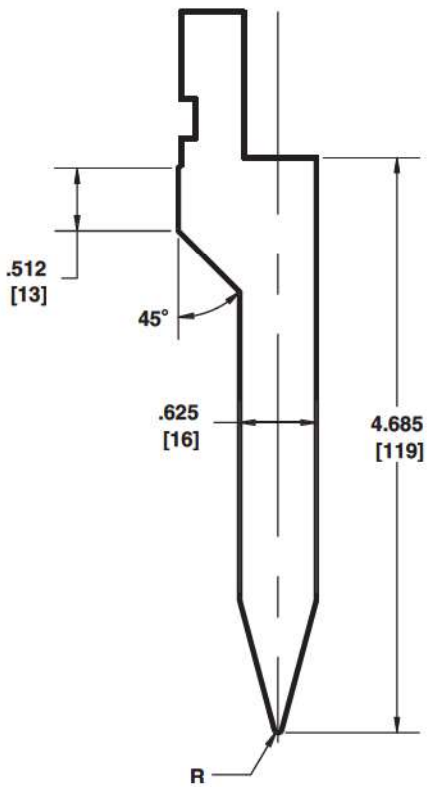

**ACUTE PUNCH @ 30 DEGREES**

Tool No.	Height	Radius
KPAE1	4.685 (119)	.031 (.8)
KPAE2	3.189 (81)	.031 (.8)
KPAE3	4.685 (119)	.063 (1.6)
KPAE4	3.189 (81)	.063 (1.6)

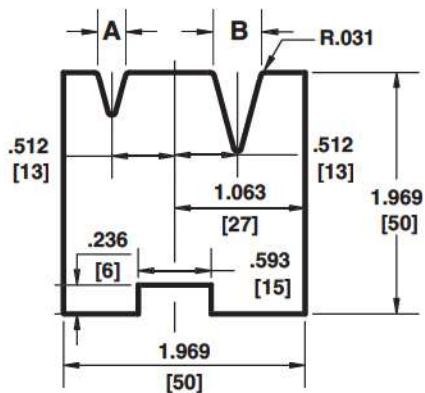

**DOUBLE ACUTE DIES @ 30 DEGREES QUICK CHANGE**

Tool No.	A	B
KDAE1	.236 (6)	.394 (10)
KDAE2	.315 (8)	.472 (12)



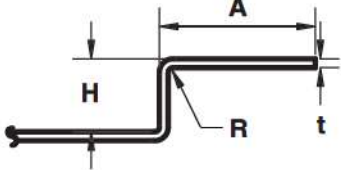
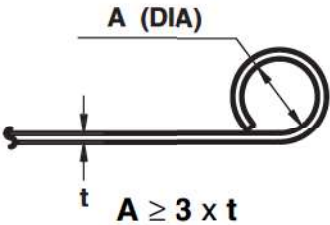
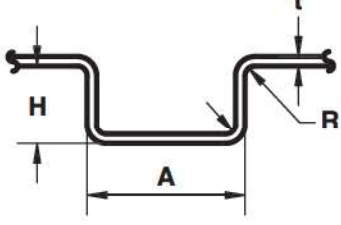
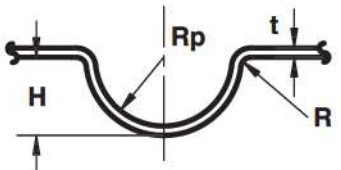
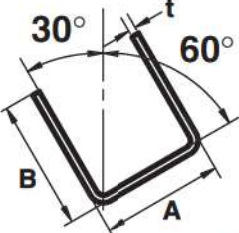
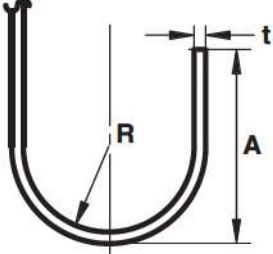
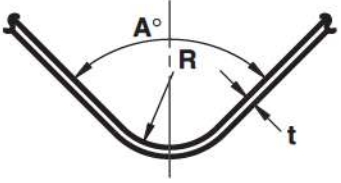
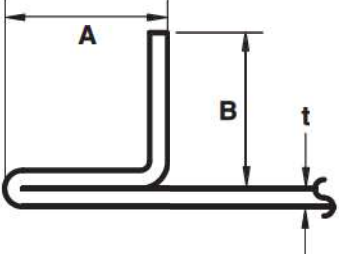
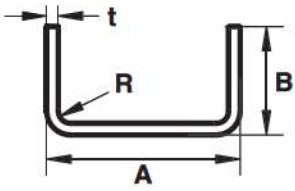

# Examples of Common Special Shapes

<p><b>Offset</b></p> 	<p><b>Off Center Curl</b></p>  <p><math>A \geq 3 \times t</math></p>	<p><b>Hat Channel</b></p> 
<p><b>Radius Rib</b></p> 	<p><b>Un-Balanced Bend</b></p>  <p>Maximum thickness 10 ga.</p>	<p><b>U-Bend with Radius</b></p> 
<p><b>Large Radius</b></p> 	<p><b>Hem with Flange</b></p> 	<p><b>U-Channel</b></p> 

**DISTRIBUTED BY**

# AHB

**TOOLING & MACHINERY**

**COMPLETE METALWORKING SOLUTIONS**

(800) 991-4225      www.ahbinc.com  
 ISO Certified      customerservice@ahbinc.com

# Kazmier Tooling Inc.

Specializing in Press Brake Tooling



## Forming Chart

Approximate pressure in tons per linear foot required to make 90 degree air bend in mild steel.  
Opening in red is the recommended opening for the given material thickness.

Thickness of Metal		WIDTH OF FEMALE DIE OPENING																					
Gage	Dec.	1/4	5/16	3/8	1/2	5/8	3/4	7/8	1.	1 1/8	1 1/4	1 1/2	2.	2 1/2	3.	3 1/2	4.	5.	6.	7.	8.	10.	12.
20	.036	2.6	2.26	1.6	1.2	1.0																	
18	.048		3.5	2.28	2.1	1.7	1.3																
16	.048			5.3	3.7	2.8	2.2	1.7															
14	.075				5.5	4.6	3.5	3.0	2.5	2.1													
13	.090					6.4	5.5	4.3	3.6	3.2	2.8												
12	.105					9.2	6.9	6.2	5.0	4.3	3.9	3.1											
11	.120						10.1	8.0	7.0	6.1	5.3	4.3	2.9										
10	.135							10.3	8.7	7.8	6.9	5.7	3.9										
9	.150								11.9	9.8	8.8	7.0	5.0	3.7									
7	.188									16.9	13.9	11.2	8.3	6.7	4.9								
1/4	.250										27.5	22.1	15.0	11.6	9.6	7.9	6.7						
5/16	.312											39.2	26.5	19.3	15.0	12.5	10.4	7.7					
3/8	.375												42.7	31.2	23.8	19.5	16.3	12.4	9.6				
7/16	.437													45.5	35.2	28.5	24.4	17.4	15.0	11.5			
1/2	.500														48.5	39.5	33.2	24.6	19.5	16.1	13.4		
5/8	.625															65.5	57.9	42.8	33.1	27.3	23.3	17.0	
3/4	.750																92.3	68.1	53.0	43.2	36.2	26.9	21.0
7/8	.875																	103.1	79.9	63.9	52.3	39.2	31.2
1	1.00																		112.1	90.4	75.5	55.7	43.7

Soft Brass / Aluminum  
Heat Treated Aluminum  
Stainless Steel

50% of Tonnage Above  
Same as Mild Steel  
150% of Tonnage Above