

AHB

TOOLING & MACHINERY

COMPLETE METALWORKING SOLUTIONS

(800) 991-4225

www.ahbinc.com

ISO Certified

customerservice@ahbinc.com

CX

Power, Length, Precision



CX4

KINGSTON

CX

Power, Length, Precision

Kingston's CX series heavy-duty precision lathes are built for cutting heavy and long workpieces for the energy, mining, textile, paper, and transportation industries. Utilizing the same headstocks and spindle bores as Kingston's tried-and-true engines lathes, the CX is available in a wide variety of configurations so you can customize your machine to your exact needs. Choose from a 4.06", 7.09", 10.1", 12.5", or 14.8" bore, 34" or 40" swing, and lengths from 80" – 280". It is equipped with a V8 hydraulic turret and 5.45 HP and 9.5 HP AC servo motors that drive the X- and Z-Axis respectively. The headstock has 4 gearshifts controlled by hydraulics for greater torque and the main spindle has a three-point bearing support system – making it ideal for cutting heavy and extremely hard materials.

Machine Highlights

- 1 **Headstock Has 4 Gearshifts** controlled by hydraulics for greater torque
- 2 **Spindle Bore: Choice of 4.06," 7.09," 10.1," 12.5," or 14.8"**
- 3 **Heavy-Duty Hydraulic V8 Turret** with 2" boring bar holders

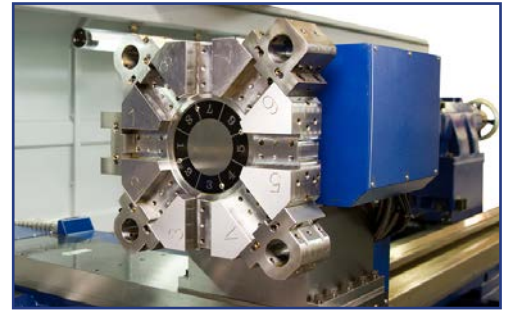

- 4 **Manual Handwheels** for quick and easy setup

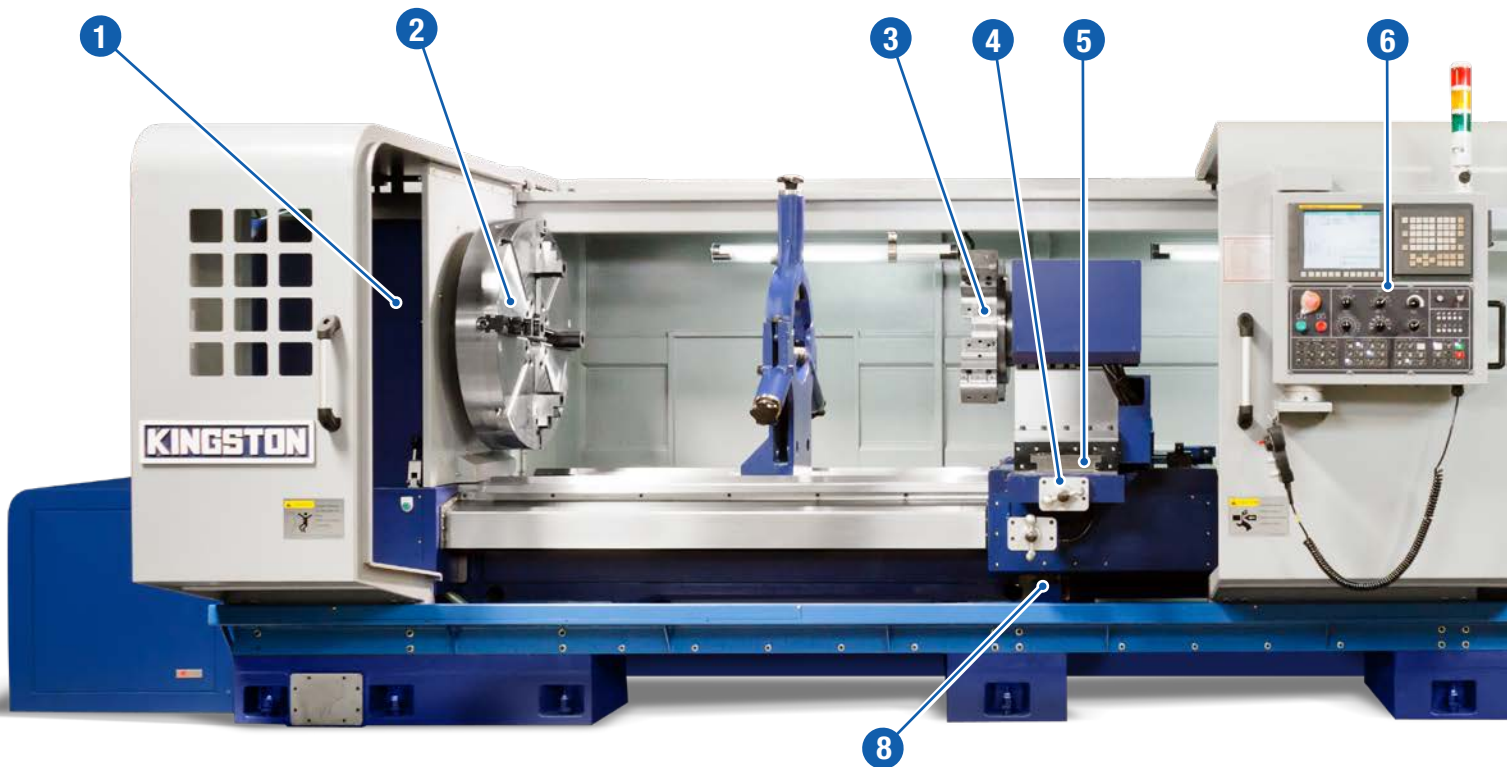

Machine Highlights

- 5** **Box Way Cross Slide** for fine and heavy-duty cutting capability

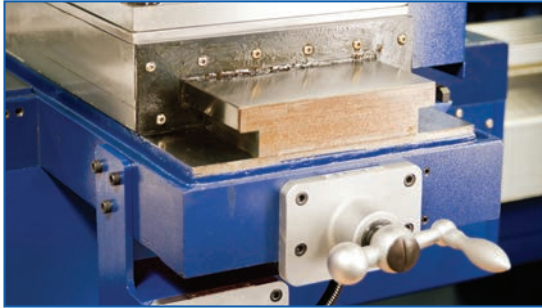

- 6** **Fanuc OiTF Controller** with Manual Guide i, 10.4" LCD monitor

- 7** **Powerful Heavy-Duty Tailstock**

- 8** **Ball Screw Supports** every 44 inches to provide greater stability

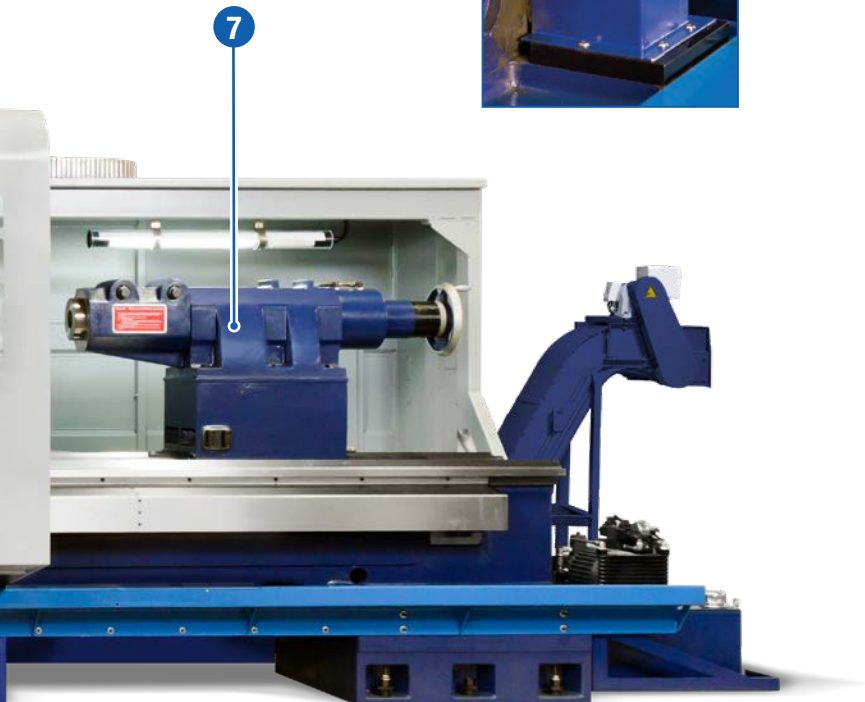

Standard Features

- Bore: 4.06", 7.09", 10.1", 12.5", or 14.8"
- Swing: 34" or 40"
- C.C.: 80" – 280"
- **CX 4:** 25 HP / 30 HP (30 min)
- **CX 7:** 30 HP / 40 HP (30 min)
- **CX 10:** 40 HP / 50 HP (30min)
- **CX 12 & CX 14:** 40 HP / 50 HP (30 min)
- 22" Bed Width
- Box Way Cross Slide on Carriage
- V8 Turret
- 11.9" Steady Rest
- Headstock Cooling System
- Hydraulic & Manual Quill Movement
- Rear Chip Conveyor with Cart
- Fanuc OiTF Controller with Manual Guide i, 10.4" LCD Monitor

Optional Accessories

- Cs-Axis with One-Degree Indexing
- Live Tooling Turret
- H4 Hydraulic Turret
- Tool Block with T-Slot
- Rear Turret
- 6" Boring Bar Support
- Siemens 828D with Shop Turn
- Variable Speed Threading



Tailstock can engage with carriage for easier movement

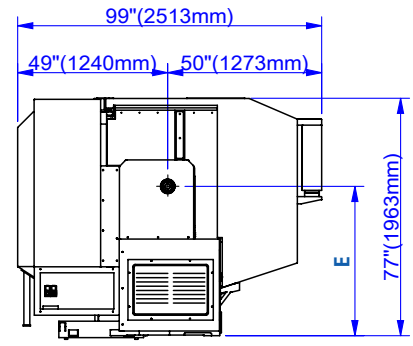
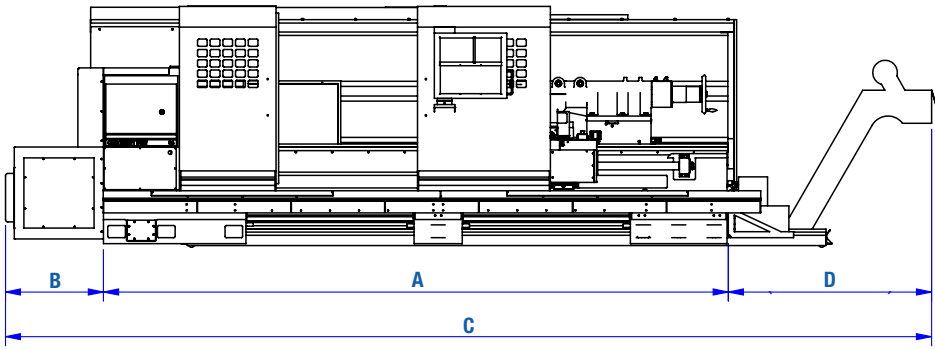

Dimensions inch (mm)	A	B	C	D
CX 2000	163" (4146)	39" (981)	268" (6807)	66" (1680)
CX 3000	204" (5166)	39" (981)	309" (7827)	66" (1680)
CX 4000	244" (6198)	39" (981)	349" (8859)	66" (1680)
CX 5000	282" (7168)	39" (981)	387" (9829)	66" (1680)
CX 6000	326" (8283)	39" (993)	431" (10956)	66" (1680)
CX 7000	365" (9271)	39" (993)	470" (11944)	66" (1680)

Swing over bed inch (mm)	E
CX 34" (870)	49" (1235)
CX 40" (1020)	52" (1310)

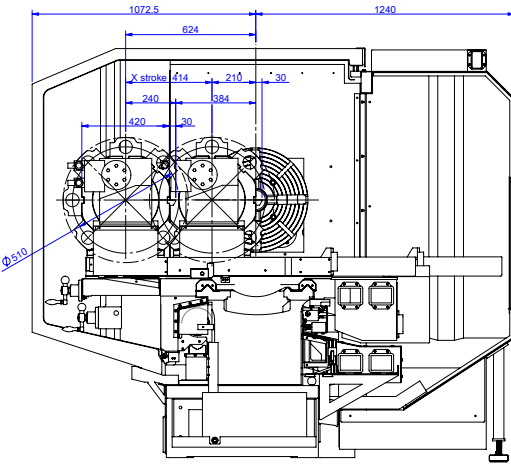

Kingston Machine Tool

5421 Business Dr.
 Huntington Beach, CA 92649
 (800) 991-4225

Capacity	34"	40"
Swing Over Bed	34"	40"
Maximum Cutting Diameter	21.6"	27.5"
Distance Between Centers	80" / 120" / 160" / 200" / 240" / 280"	
Width of Bed	22"	
Headstock		
Spindle Bore	4.09" / 7.09" / 10.1" / 12.5" / 14.7"	
Spindle Motor	25 HP / 30 HP (30 min) (CX 4), 30 HP / 40 HP (30 min) (CX 7), 40 HP / 50 HP (30 min) (CX 10, CX 12, CX 14)	
Type of Spindle Nose	A1-11 (CX 4), A2-15 (CX 7, CX 10), A2-20 (CX 12, CX 14)	
Hght. Floor to Spindle Center	48.6"	51.5"
Gear Box		
Number of Speed Ranges	4	
Spindle Speed (RPM)	8 – 800 (Std) or 12 – 1200 (Opt) (CX 4), 7 – 750 (CX 7), 6 – 600 (CX 10), 10 – 400 (CX 12), 10 – 300 (CX 14)	
Turret	V8 Hydraulic (Std) or H4 Hyd (Opt. CX4, CX7, CX10, CX12)	
Traverse		
Max. Stroke X-Axis	20.1"	
Max. Stroke Z-Axis	86.6" / 126.0" / 165.3" / 204.7" / 244.1" / 283.4" (CX 4) 86.6" / 125.98" / 165.3" / 204.7" / 244.1" / 283.4" (CX 7, 10, 12, 14)	
Rapid Traverse X-Axis	157 in/min	
Rapid Traverse Z-Axis	236 in/min	
Motor		
X-Axis Servo Motor	5.3 HP	
Z-Axis Servo Motor	9.4 HP	
Ball Screw		
X-Axis	ø1.26", P = 5	
Z-Axis	ø2.5", P=10 (< 200") / 3.15", P=10 (200" or longer)	
Tailstock		
Tailstock Quill Center	M.T. # 6	
Tailstock Quill Diameter	Ø5.9"	
Tailstock Quill Travel	8.6"	
Dimensions		
Floor Space (CX 4, 10-14)	99" W	261" / 302" / 342" / 380" / 431" / 470" L
Floor Space (CX 7)	99" W	268" / 309" / 349" / 387" / 431" / 470" L
Weight (lbs)		
CX 4 34"	15,000 / 17,200 / 19,400 / 21,600 / 23,800 / 26,000	
CX 4 40"	15,400 / 17,600 / 19,800 / 22,000 / 24,300 / 26,400	
CX 7 34"	18,040 / 20,240 / 22,440 / 24,640 / 26,840 / 29,040	
CX 7 40"	18,480 / 20,680 / 22,880 / 25,080 / 27,280 / 29,480	
CX 10 34"	18,480 / 20,680 / 22,880 / 25,080 / 27,280 / 29,480	
CX 10 40"	18,920 / 21,120 / 23,320 / 25,520 / 27,720 / 29,920	
CX 12 34"	18,480 / 20,680 / 22,880 / 25,080 / 27,280 / 29,480	
CX 12 40"	18,920 / 21,120 / 23,320 / 25,520 / 27,720 / 29,920	
CX 14 34"	18,480 / 20,680 / 22,880 / 25,080 / 27,280 / 29,480	
CX 14 40"	18,920 / 21,120 / 23,320 / 25,520 / 27,720 / 29,920	
Total Power Required	50 KVA (CX 4, CX 7) / 60 KVA (CX 10-14)	