

# PlateProXHD™



## CNC PLASMA & OXY-FUEL CUTTING MACHINE

**AHB**  
TOOLING & MACHINERY

COMPLETE  
METALWORKING  
SOLUTIONS

(800) 991-4225  
www.ahbinc.com  
ISO Certified  
customerservice@ahbinc.com

**KOIKE**  
ARONSON RANSOME

# PlateProXHD™



## Operator Console

Hard-wired switches for powering machine, selecting oxy-fuel station, operation and E-stop button. Swivels to the left or right for better ergonomic machine operation.



Shown: Cutting table and IHT cutting torch optional

Koike Aronson Inc./Ransome has designed the PlateProXHD to provide excellent thermal cutting at an affordable price. This automated dual side drive, plasma/oxy-fuel cutting machine is cost efficient and is manufactured in the U.S.A. There is also a two-year warranty. The PlateProXHD utilizes the latest technologies to provide unmatched speed, accuracy, versatility and durability in a thermal cutting machine. Designed to satisfy the world's most demanding customer requirements, the PlateProX HD has been engineered to maximize its' performance while costing so little. Steel Service Centers, Heavy Fabricators, Tank Manufacturers, Shipbuilders and General Fabricators are just a few of the PlateProXHD target customers.



## Operator Station

with handles, for ease and comfort.

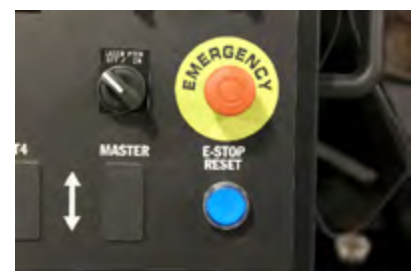

## Emergency Stop Button

E-Stop button quickly and safely shuts off machine motion and cutting process, including oxy-fuel gases to the torches.



# STANDARD EQUIPMENT



**Limit Switches**  
Used for over-travel as well as homing of the machine.



**Koike Engineered Main Electrical Enclosure**  
Offers "off-the-shelf" components including Yaskawa drives and motors.

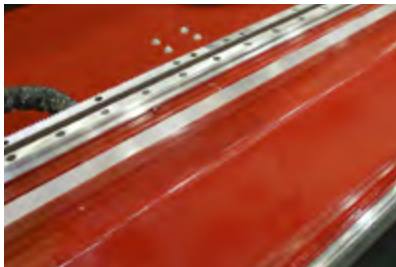

**Linear Way and Helical Rack**  
25mm linear rails and AGMA 12 helical rack and pinion provides smooth and accurate motion.

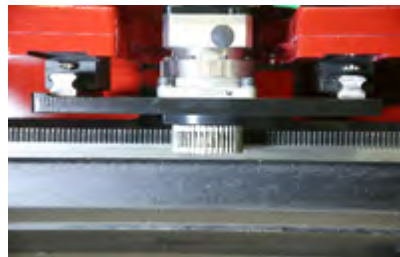

**Large Diameter Drive Pinions**  
Large diameter pinions offer accurate and smooth machine motion.

**Main Beam Construction**  
Solid steel fabricated construction. Includes precision machining for linear bearings and rack.



**Floor Mounted Rails**  
**Mounted on a fixed base plate**  
Provides highly accurate symmetry for the basis of precision cutting and smooth motion. Allows expansion of rail length and use on a common rail for two or more machines.

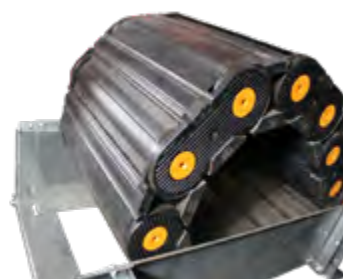

**Rail Axis Cable Carrier**  
Can be mounted on the floor or overhead.

# OPTIONAL CNC CONTROLS



## Edge Connect TC - CNC Controller

- Windows® 10 Embedded
- Intel J1900 Quad Core MCU or equivalent
- 120GB SSD Hard Drive or better
- 4 GB DDR3 or better
- 19 inch Glass Touchscreen with 1366x768 Native resolution
- IntelliTouch Pro PCAP (Projected Capacitive touch technology)
- 2 USB 2.0 Ports
- Built in Wireless Communication
- Two Plasma Station Operator Console
- Forward and backup on path function
- Skip to pierce or Skip part function
- Part Program Support
- Remote Help
- Supports Networking
- Auto Gas Support
- DXF Input
- Simple Shape Nesting
- Select-able Process Parameter table
- Cut Pro Wizard
- Pronest CNC version included (single part nesting)
- Optional multiple part nesting available upon request
- Sure Cut technologies applied (True hole, Rapid Part and True Bevel when applicable)

# PLASMA SYSTEMS & OPTIONS



## Hypertherm® XPR 170 & 300

Redefining what plasma can do.

### High Definition and Conventional Plasma Systems

Automatic or Manual gas setting. Koike Aronson offers high quality plasma cutting systems by Hypertherm®.

Each of these systems offer a wide variety of features and benefits. From the most basic systems to the most advanced in the market, KOIKE offers a plasma that is sure to meet your needs.

Choosing the right options for your application is not easy. Many options exist for the PlateProX HD. When you decide to buy a cutting machine from KOIKE, not only are you getting a high quality machine designed to perform and last, but most importantly, you are getting the know-how that comes with almost a century worth of experience.

Your application, your job and your factory come first. You'll find that working with our Cutting Machine Business Unit means attention to detail and finding the right machine that fits your application(s) and your budget too.

## HyPerformance Plasma HPR® XD



**HPR400xd**  
Production Pierce 2" Mild Steel

**HPR800xd**  
Production Pierce 2" Mild Steel

## powermax<sup>series</sup>



## MAXPRO200®

Production Pierce 1" Mild Steel  
Liquid Cooled



powermax65- Production Pierce 1/2" Mild Steel

powermax85- Production Pierce 5/8" Mild Steel

powermax105- Production Pierce 3/4" Mild Steel

powermax125- Production Pierce 1" Mild Steel

# PLASMA SYSTEMS & OPTIONS



## 3D-X Full Contour Bevel Head

- Performs A, V, X, Y, & K bevels
- One touch homing
- One touch alignment
- Integrated torch breakaway
- Concealed A/B axis motor and encoder cables
- Fast, smooth and precise motion
- Helical rack and pinion lifter design
- Can accommodate small corner loops
- Better hazard clearance at Y-axis 45 degrees



## Manual Plasma Bevel Station

Bevel in the rail axis only.  
Non-contour mechanical adjustment  
from +/- 0 to 45°.



## Koike Integrated Sensor THC (Torch Height Control)

- 12" (340.8 mm) Lifter Travel
- 1,000 IPM Programmable Lifter Speed
- Adjustable stroke retract between cuts
- Dynamic positioning.

## Collision Detection Mount

- Magnetic integral breakaway for collision detection and system shutdown
- Primary Ohmic contact plate sensing for clean plate
- Secondary plate sensing means for scaled rusty plate
- Primary and secondary means for lifter homing



## Laser Pointer

Allows operator a visual indicator for  
plate alignment and torch positioning.

# MARKING OPTIONS



## Plasma Plate Marking

Low amperage plasma marking with  
the ability to adjust marking depth  
through the CNC parameters.



## Pneumatic Dot-Peen Pin Stamp Marker Station

Carbide tipped variable speed  
punch for marking bend lines,  
layout lines, drill locations and  
lettering/numbering as small  
as 1/4" high.



# OXY-FUEL SYSTEMS & OPTIONS



## Hi-Lo Oxy-Fuel Gas System with Auto Ease-On

Allows hi-lo preheat for fast preheating of plate and superior cutting quality. Features auto ease-on pierce control for cut oxygen. Allows for precise piercing on thicker plate. Maximum 4 in (100 mm) thick material with 4 torches.

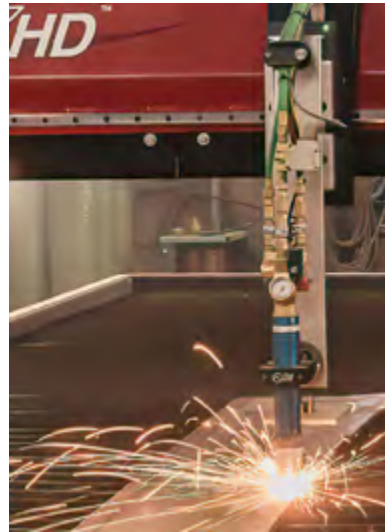

## IHT Torch Station

Offers:

- Auto ignition
- Auto capacitive height control
- Long tip life
- Quick change tip technology

## Oxy-Fuel Torch Stations (Up to four stations available)

Model "G" motorized lifter, 6-inch (150 mm) stroke at 40 IPM. All stations are controlled from Operator console. 500L Koike torch offers 1/8" to 12" (3mm to 300mm) thick plate cutting available. Capacitive height control (not shown) and automatic ignition available (optional).

## Auto-Gas Oxy-Fuel Gas System

Precise control of gas manifold pressure. CNC controlled oxy-fuel processes.

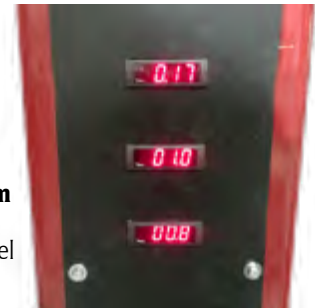

## Koike Torch Bevel Head Attachment

The bevel head attachment is used in place of a Koike cutting tip. It is used for bevel cutting operations, including top and bottom bevel cuts.



## Koike Twin Tip Holder

Covers a single oxy-fuel cutting torch into dual cutting torches. Allows strip cutting and a closer distance between small parts.



## Koike Oxy-fuel Process Support (KOPS) technology

Requires

- Fit-3 Oxy torch station with ignition and height control
- Koike Auto-gas control system for oxy torch.
- ProNest Software

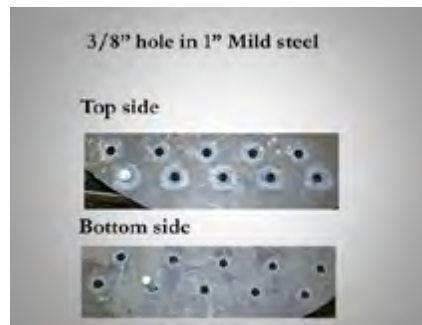

# TABLE OPTIONS

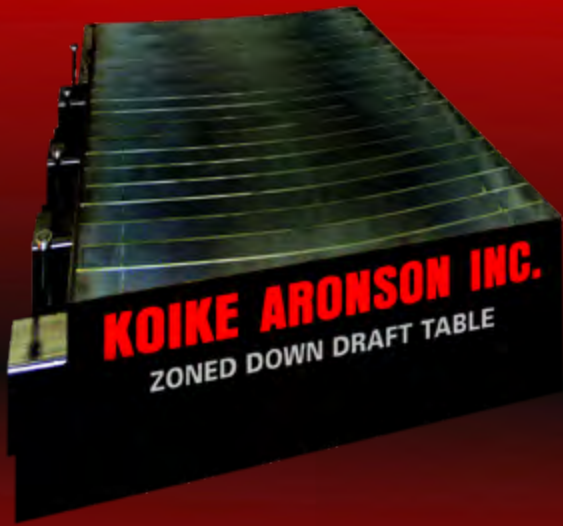

## Koike Zoned Downdraft Cutting Table

The Koike Downdraft table is as big, or as small, as most workpieces you've got. Its modular design lets you add space as you need it, with a maximum material thickness of 6 in.

Operation is simple: there are no electronic components, and slat frames and slag pans remove easily for cleaning. Fume extraction is everything you need, thanks to multiple zones for optimal fume extraction. Downdraft tables are used primarily for plasma cutting and combined with fume extraction units that filter the air back to the factory. Downdraft tables provide the best option for high-quality cutting with high-density plasma systems.



## Koike Water Cutting Table

The Koike water cutting table is an economic solution to reducing smoke, sparks and dust into the environment. It can be used for both oxy-fuel and plasma cutting. While not the most optimized solution for high density plasma systems, it still provides good results in cut quality. Constructed out of 1/4" thick steel the table offers a heavy duty design with re-enforced side walls for extra durability.

The steel tank air bladder allows raising and lowering the water lever with air. The design of the table allows 6" thick plate and under to be leveled to the table for more accurate cutting.

1/8" thick slats are spaced 3" apart and curved to help stop small parts from falling into table and prevent straight line cutting along a slat. This feature reduces slag along the bottom of parts and prolongs the life of the slats.

Easy lift lugs allows you to lift the whole slat and pan assembly or each individual component of this assembly. As an example: it allows for the lifting of slats and the holder for easy access to collector pans.

## Optional Fume Collectors



## Fume Extraction Unit

- For downdraft table

Effective Cutting Width  Effective Cutting Length

Material Types:

### Material Thickness Range

Plasma Thickness

Oxy-Fuel Thickness

### Rail Axis Cable Carrier

Floor Mounted

Overhead Mounted  
9m maximum length

### Plasma System

Hypertherm®

### Plasma Bevel

Manual Type

3D-X Full Contour

### Plasma Height Control

Koike Sensor - THC

### Plate Marking

Pneumatic Dot Peen

### Offline Software

Hypertherm® CAM Solutions

### CNC Controller

Hypertherm® EDGE Connect

### Plasma Type

Quantity:

Voltage:

Hi-Definition

### Oxy-Fuel

Quantity  Fuel-Gas Type

Auto Ignition

Capacitive Height Control

Manual Bevel Attachment

IHT Torch

### Cutting Tables

Pneumatic Water

Dry

Downdraft

Fume Collector



Scan to fill out



# SPECIFICATIONS

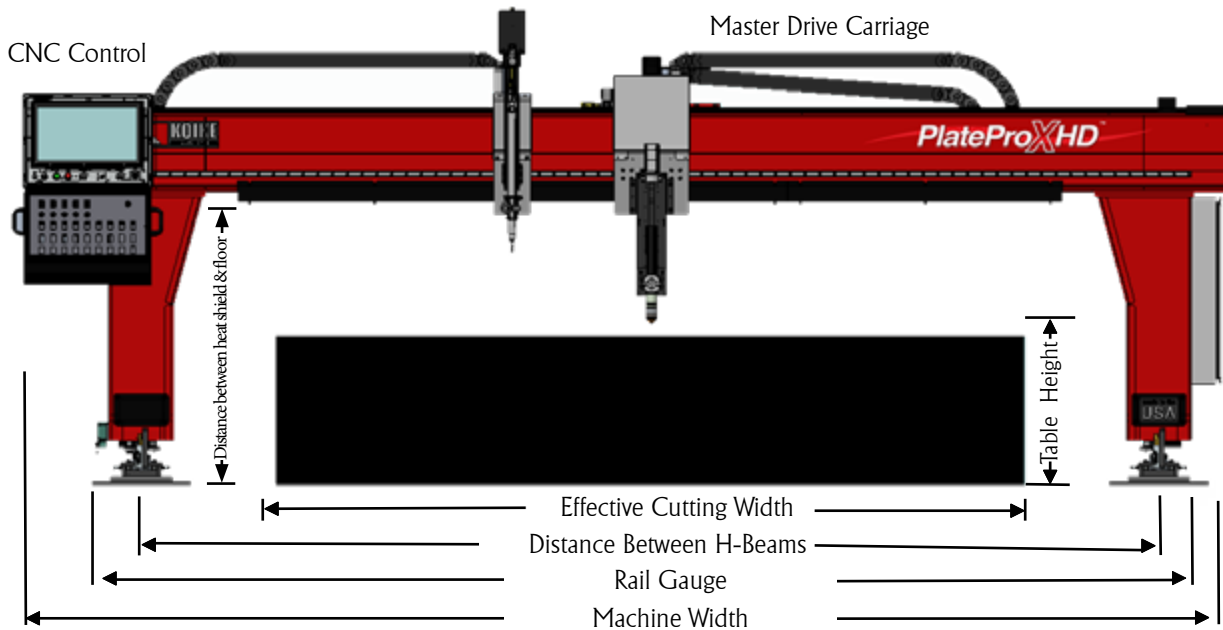

MODELS	PLPXHD 2000	PLPXHD 2500	PLPXHD 3100
Effective Cutting Width (Master)	72 in	96 in	120"
Distance Between Rail Pads	98 ¾ in	122 ¾ in	146 ¾ in
Machine Rail Gauge	114 ¾ in	138 ¾ in	162 ¾ in
Machine Width	160 in	184 in	208 in
Table Height	30 in	30 in	30 in
Distance between heat shield & floor	44 ⅞ in	44 ⅞ in	44 ⅞ in
Effective Cutting Length (Expandable)	168 in	168 in	168 in
Machine Rail Support H-Beam	22kg Floor Mount	22kg Floor Mount	22kg Floor Mount
Rapid Traverse Speed	1500 IPM	1500 IPM	1500 IPM
Contour Speed (Maximum)	400 IPM	400 IPM	400 IPM
Machine CNC	Hypertherm® EDGE Connect	Hypertherm® EDGE Connect	Hypertherm® EDGE Connect
Machine Drive System	AC Servo	AC Servo	AC Servo
Maximum Number Of Slave Stations	3	3	3
Maximum Plasma or Marker Stations	2	2	2
Maximum Oxy-Fuel Stations	4	4	4
Oxy-Fuel Gas System	Hi-Lo/Auto	Hi-Lo/Auto	Hi-Lo/Auto
Machine Voltage	208-230/1 or 3 phase / 60		

Specifications subject to change without notice.



# POSITIONING MACHINE LINE

## Turning Rolls



## Applications



## Tilt/Turn Welding Positioners



## Headstocks/Tailstocks

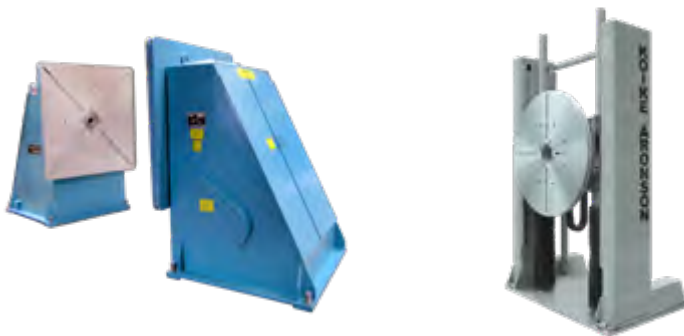

## Manipulator, Universal Balance, Retrofit/Rebuilds





# PORTABLE & GAS APPARATUS

## Portable Cutting Machines

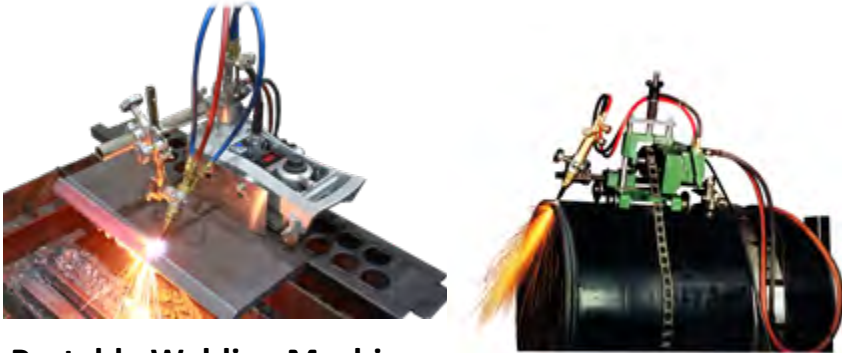

## Applications



## Portable Welding Machines



## Hand Torches



## Cutting & Welding - Gas Safety







# COMPLETE METALWORKING SOLUTIONS

**(800) 991-4225**

[www.ahbinc.com](http://www.ahbinc.com)

ISO Certified

[customerservice@ahbinc.com](mailto:customerservice@ahbinc.com)



[www.koike.com](http://www.koike.com)

#### **Headquarters**

635 W. Main Street  
PO BOX 307  
Arcade, NY 14009

#### **Koike Aronson Brasil**

Estrada dos Romeiros, 6116-Galpão 97  
Santana de Parnaíba- SP Brasil

PLATEPROXHD 03/20 KENG