



## QUICK LOAD SERVO S3 T BARFEED

SHORT AUTOMATIC BAR FEEDER FOR  
SPINDLE LENGTH BARS FOR FIXED OR  
TRAVELING HEADSTOCK TURNING  
MACHINES

Diameter range: 1/4" to 4 - 3/4"  
(6 mm to 120 mm)

Overall barstock length: 5" to 63"\*

\*Not to exceed overall length of spindle



YOUR "ONE-STOP-SHOP"  
FOR MACHINE-TOOL PERIPHERALS

# AHB

**TOOLING & MACHINERY**

**COMPLETE METALWORKING SOLUTIONS**

(800) 991-4225

[www.ahbinc.com](http://www.ahbinc.com)

ISO Certified

[customerservice@ahbinc.com](mailto:customerservice@ahbinc.com)



### Higher Productivity and Better Value

Our breakthrough in bar feeding technology reduces changeover time to seconds to dramatically improve your productivity. LNS designed the space-saving Quick Load Servo S3 T with unique features to improve speed, productivity and versatility for bar feeding and automatic bar loading of small and medium batches.

You'll enjoy increased productivity with:

- Fastest changeover time
- Fully automatic diameter adjustment
- Unattended operation and reliability
- Unmatched versatility and flexibility
- Diameter range and capacity

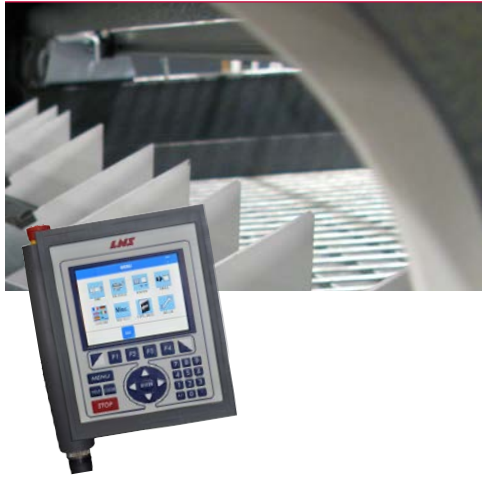

### Increasing Your Productivity With Quick Production Setup Changeovers, The Fastest in The Industry

Start-up and diameter changing can be performed in record time thanks to the enhanced intuitive controls. The user friendly touch screen HMI with prompting menu screens ensures the interaction between the bar feeder and the lathe, and therefore the production process can be run safely and efficiently.

The remote control is ultra light featuring easy set up and operation. It displays alarm description, alarm history of operation errors and position tracking (inch/metric programming).

The Quick Load Servo S3 T automatically makes all changeover adjustments by answering three simple questions when prompted by the remote control:

1. Stock Shape?
2. Stock Diameter?
3. Part Length?

Input any additional parameter information related to the application. And all changeover adjustments happen automatically.

Within the pusher diameter your changeover is complete in seconds. The Quick Load Servo S3 T takes the information and automatically makes these adjustments:

- Bar to centerline of the lathe
- Magazine storage bar selection mechanism to bar diameter ensuring one bar is loaded at a time
- Feed and torque rates



### Increasing Production Efficiency Through Innovation

The Quick Load Servo S3 T has surpassed industry technology by incorporating a "Parts Library", which is a 500 parts storage feature. The "Parts Library" allows the user to store specific parameter configurations that are unique to a machining program.

Whether you need to run the job now or at a later time, simply selecting the desired part number from the "Parts Library" will instantly restore the appropriate data.

Enhanced with the embedded Web server in the PLC allowing the barfeeder to share data with the CNC machine tool via LNS e-Connect. Ethernet interface with LNS e-Connect programmed parts in the library can be selected via CNC program.

(CNC software must support Ethernet interface)





### Greater Capacity for Extended Runs

The Quick Load Servo S3 T offers a 39" wide magazine tray for large capacities for unattended operation (up to 1,200 pounds\*). The adjustable tray permits optimum application adjustments (hex, square, etc.) including a safety switch for safely reloading. Front or rear load for optimum utilization of floor space when loading magazine tray.

\*Maximum 150 lbs. per bar



### Speed, Versatility and Flexibility

In addition to fast changeovers, the Quick Load Servo S3 T offers these features:

- Accommodates round, hex, square and odd shaped material
- Feed to part length with or without turret
- Complete load cycle time of new bar stock: 15 seconds
- Complete changeover from one diameter to another: 15 seconds
- Linear ways permit feed rates up to 4,000 IPM
- Positioning accuracy is .004 inches with proper chucking device on the turning machine
- Features mechanical stop capability for end loading applications

The versatile Quick Load Servo S3 T can be converted from bar loading to high-production shaft loading within minutes and even to a one shot shaft application to load shaft within 4 seconds.

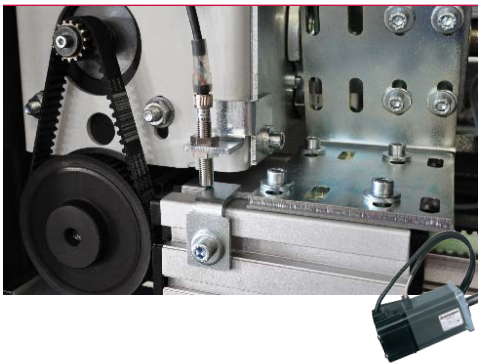

### For Faultless Unattended Operation

The highest-quality parts are used to keep you at optimum productivity, no matter what shift, no matter what day. Downtime is costly; the Quick Load Servo S3 T has the reliability to keep you running through all shifts, even unattended operation, with a menu-driven remote control, Mitsubishi servo drive and absolute encoder, hardened rollers eliminate friction during loading cycle and a 39" storage rack, the largest in the industry.

The LNS servo motor control technology provides the Quick Load Servo S3 T with a precision of bar positioning which is unrivalled on the market.\* It guarantees accurate bar feedout control with or without turret help and prevents from hitting the turret with its soft touch positioning.

\*LNS recommends "pull-to-close" dead length collet chuck or 3-jaw chuck to maintain position accuracy.

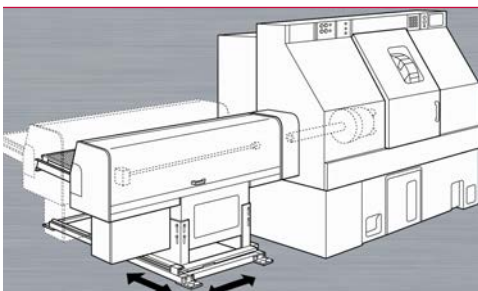

### E-Z Spindle Liner Changeover

Facility cleanliness can boost production morale and keep your production running smoothly free from debris.

Standard Z or X axis retraction system can be chosen at time of installation and allows E-Z spindle liner changes and machine access.



Specifications subject to change without notice



# QUICK LOAD SERVO S3 T BARFEED

## TECHNICAL SPECIFICATIONS

Capacity		
Diameter	mm	6 - 120
Bar Length (5" to 63")	mm	100 - 1600 not to exceed overall length of spindle
Loading System		Side Load Rack
Loading Capacity	mm	1000 (39")
Loading		Front / Rear
Shipping Weight	lbs	1,750
Applications		
Type of Headstock		Fixed / Traveling
X or Z Axis Retraction	mm	600 (23")
Changeovers		
Partial changeover	sec	15 or less
Complete changeover	min	1 or less
Driving Systems and Bar Support		
Motor		Servo
Drive		Notched Belt
Other		
Parts Library		500 Parts Program Storage

Barstock Straightness Specifications and Performance

For optimum rotational performance speeds, bar stock straightness needs to be .020" per 3.25 feet, non accumulative. Bar stock out of this tolerance will not run at optimum RPM. Other factors such as material type (brass, copper, bronze and other malleable materials), clamping efficiency of the machine workholding, alignment of the bar feed, oil type, bar preparation and spindle liners will affect optimum RPM capability of the system.

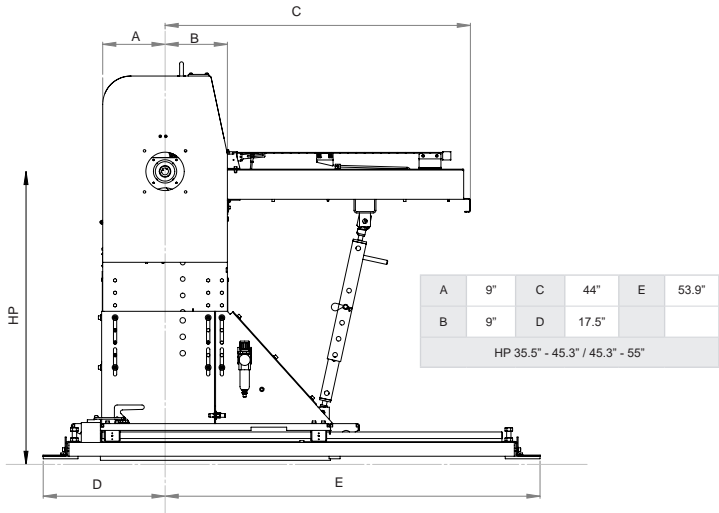
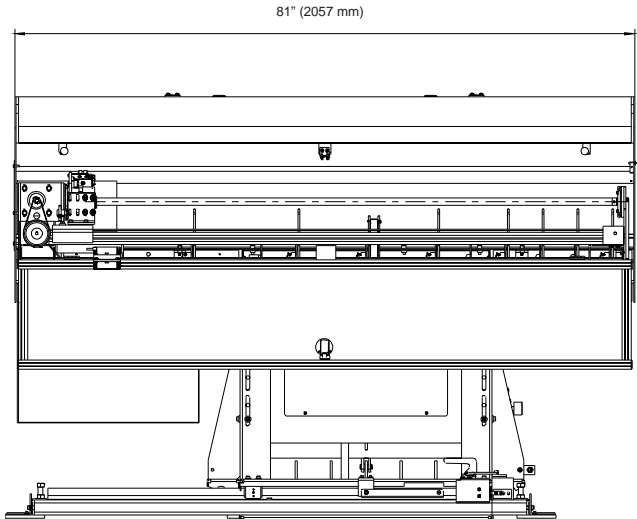

**YOUR "ONE-STOP-SHOP" FOR MACHINE-TOOL PERIPHERALS**

LNS provides a full range of barfeeders, chip conveyors, coolant management systems, air filtration systems, and workholding systems that is second to none on the market. We are known in the industry for the solid experience we have gained over several decades in an exceptionally wide range of applications, our excellent customer service, and our technical support. This support is ensured by highly qualified technicians who are available throughout North America.



**(800) 991-4225**  
[www.ahbinc.com](http://www.ahbinc.com) • [customerservice@ahbinc.com](mailto:customerservice@ahbinc.com)  
**ISO Certified**



LNS America, Inc.  
 ISO 9001-10013185  
 LNS Turbo  
 ISO 9001-10000276

Facilities covered by this mark have been evaluated to international quality assurance standards by UL DQS Inc.

Specifications subject to change without notice / Quick Load Servo S3-T / 07-2016