

# MultiCam<sup>®</sup>

**ROUTER**



**DIGITAL FINISHING**



**KNIFE**



**PLASMA**



**WATERJET**



**LASER**



Tooling & Machinery, Inc.

Complete Metalworking Solutions





**Many Platforms.  
Infinite Applications.**





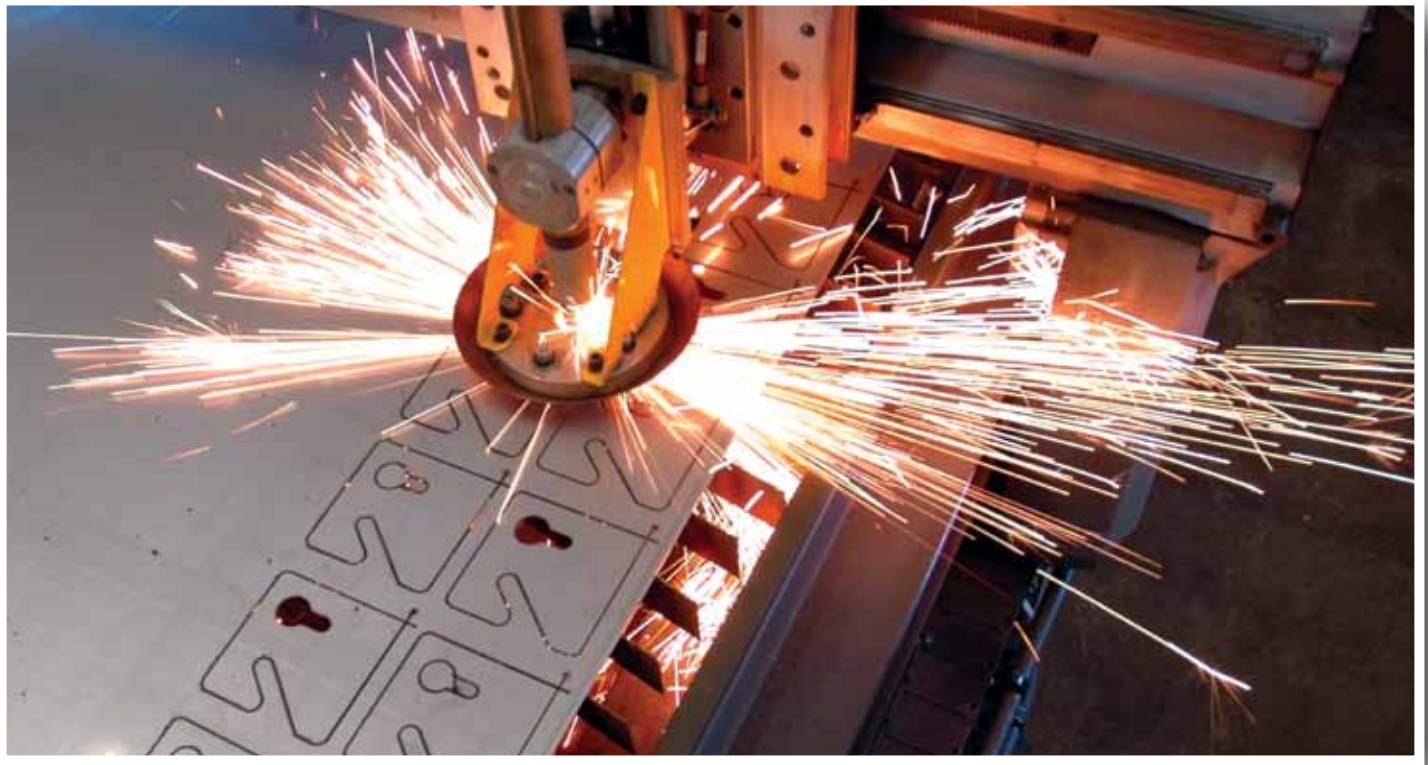

## Discover Global MultiCam® Power



A global force in innovative mechanized CNC cutting solutions, MultiCam® Inc. manufactures router, digital finishing, knife, plasma, waterjet and laser machines. These versatile tables cut and process a wide variety of materials including wood, metal, plastic, cardboard, rubber, stone and many others.

The continually growing MultiCam customer base is worldwide. We've installed over 9000 platforms in industries ranging from aerospace to automotive, signmaking to digital finishing, sheet-metal to plate-steel fabrication, hardwood processing to cabinetmaking and thermoform trimming to plastic fabrication.

Since 1989, thousands of companies have chosen MultiCam for our diverse, high-value, easy-to-use product line that meets their top priority of productivity. With a worldwide network of over 70 Technology Centers, you'll find a location near you for sales, demonstrations, training, service and support.

At MultiCam, we build every machine to order based on your unique manufacturing requirements. Other machinery companies sell predefined models that can limit your capabilities. For businesses like yours that think outside the box, MultiCam's customized yet affordable automation is simply the best choice and value.

No matter what you cut, MultiCam will configure the right CNC solution for your application and budget.



Cam 5000

MULTICAM

*At MultiCam, we envision, engineer, manufacture, market and support a variety of custom CNC cutting solutions.*





## Apply Industry-Leading Technology

MultiCam envisions, engineers, manufactures, markets and supports a variety of custom CNC cutting solutions. We integrate advanced technology and value into highly productive, easy-to-use systems that we build to last.

### ***World-Class Engineering***

The engineering process begins with customer studies and discussions. Once we understand your needs, we create a solution to satisfy your requirements. Our world-class design team utilizes state-of-the-art CAD systems to design, verify and document all MultiCam products. We research resourceful cutting-edge technologies continually to improve all of our CNC machines and maximize output. The key word at the end of each day is *productivity!*

### ***In-House Manufacturing***

With our factory under one roof, we ensure quality control throughout the manufacturing cycle. Unlike other companies that simply assemble machines after outsourcing parts, MultiCam manufactures most everything in house. Because we're in the automation business, we utilize this technique in every manufacturing application we can.

### ***Prompt Worldwide Technical Support***

MultiCam Technical Support is just a phone call away! Factory-trained technicians at each Technology Center around the globe are prepared to diagnose and solve problems. In-stock spare parts are ready to ship from your local distribution center. These regional experts assure timely assistance whenever you need help.

*We build every MultiCam to order based on each customer's unique manufacturing requirements.*







## Increase Productivity and Profits

### ***World Headquarters Welcomes Customers***

MultiCam Inc. Headquarters and our North Texas Technology Center are located in Dallas, Texas. Just minutes from Dallas/Fort Worth International Airport, access is convenient for both international and domestic customers. MultiCam's two buildings encompass a total of over 135,000 square feet of product development, manufacturing and corporate office facilities. Come meet Team MultiCam for personalized plant tours, consultations and application demonstrations.

### ***Boost Your Bottom Line***

Automating a cutting process with a MultiCam sends profits to the bottom line. That's how we help you *achieve* your cost-saving goal to make accurate parts faster with reduced waste, less labor and shorter lead times.

Schedule a consultation with Team MultiCam at [www.ahbinc.com](http://www.ahbinc.com) to discuss your unique application requirements. You'll also discover how we individualize solutions to maximize your productivity.

# Operating a MultiCam is



MultiCam **EZ** G-Code ▶

## Advanced Graphical CNC Interface

MultiCam's exclusive EZ G-Code programming software allows any operator to create a CNC file using CAD or illustration programs without the need to know M & G coding. Just focus on the finished product rather than on learning a new system.

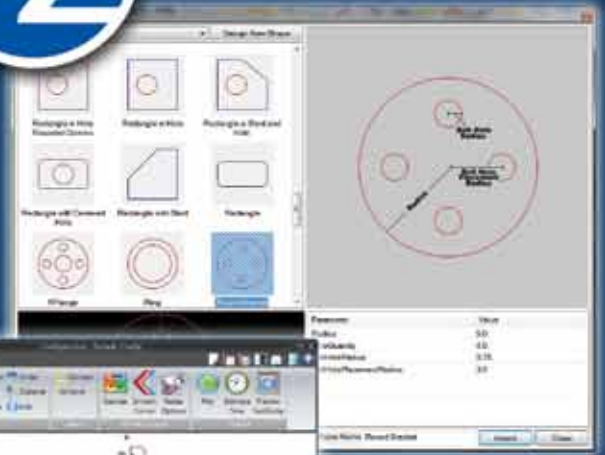
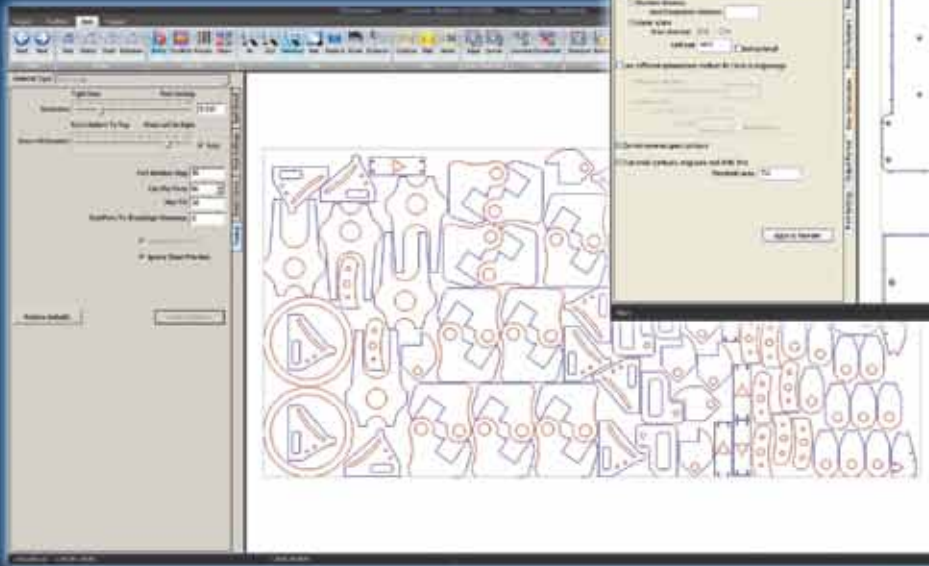

MultiCam **EZ** Control ▶

is the heart of every MultiCam cutting solution.







## Maximize Quality with Automation

### ***Anyone Can Operate the MultiCam EZ Control®***

Our exclusive EZ Control® is the heart of every MultiCam cutting solution. Incorporating state-of-the-art CNC technology, it features an incredibly easy-to-use human-machine interface that separates it from the competition. EZ Control allows you to use your existing workforce. The control's hand-held interface eliminates the need for operators to be G-code literate. Its large graphic icons control complex movements, and the long cord allows portability. Any shop employee with a few minutes of training can operate a MultiCam machine, enabling you to take your profits to the next level.

### ***Common Parts Benefit Everyone***

Using common parts brings cost, availability and economies of scale into line. EZ Control is a common part on all MultiCam machines, and many of our standard parts are interchangeable. Linear bearings, rack and pinions, ball-screw assemblies, electronics and motor systems are all the highest quality off-the-shelf parts for fast, convenient replacement.

### ***Quality is a MultiCam Essential***

We engineer each electromechanical assembly to perfection with the finest components including linear and helical rack-and-pinion drives, closed-loop brushless ac servos and heavy-duty precision linear guideways and bearings. MultiCam documents all electronics fully with complete schematics. We construct all frames from high-grade steel that we precision cut, weld and stress relieve prior to precision machining. Each of these components produces linear, parallel and perpendicular motion platforms that must meet the MultiCam quality seal of approval.





*MultiCam Québec, Canada*



*MultiCam GmbH, Germany*

**Our network of experts  
features over 70  
MultiCam Technology  
Centers worldwide.**



*MultiCam Midwest, Illinois*



*MultiCam China*



*ABC/MultiCam, Colorado*



*MultiCam Republic of South Africa*



*MatCam OZ, Australia*



*MultiCam Great Lakes, Michigan*



*Perez Camps, Spain*



*HaWe Systems, Czech Republic*



# Utilize Local Technology Centers

Manufacturers have marketed factory automation machinery to end users through a variety of distribution networks over the years. Many use a sales rep system with the factory providing all service and support. While this may be an effective selling method, it compromises service and support if the factory is in a different time zone and on-site service requires added expense.



**MultiCam Great Lakes  
Grand Rapids, MI**

MultiCam Inc. pioneered the Technology Center concept in the early 1990s. We implemented a dedicated network of regionally based offices to provide full sales, demonstration, training, service and post-sale support capabilities.

Each MultiCam Technology Center has a demonstration area so you can evaluate machine features, time studies, etc. Just take your parts to your local facility, and the staff will show you how to cut them!

Factory-trained technicians install your machine and train your operators.

Well versed in a variety of CAD/CAM software packages, every Technology Center staff can recommend and support your CNC programming requirements as well.

Your MultiCam machine comes with a comprehensive warranty so you can be confident in your purchase. However, every machine has normal wear parts and will require periodic maintenance. The most common replacement parts usually are available immediately from your local Technology Center.



**MultiCam's corporate Customer Service and Technical Support  
Departments serve our worldwide network of Technology Centers.**

Whenever you have questions or need post-sale support, contact your local MultiCam Technology Center. Personnel are ready to provide phone and online support, resolving most problems without an in-person service call. With over 70 Technology Centers worldwide, we're working hard to make your MultiCam purchase the best investment possible.

# MultiCam Factory Tour



MultiCam's 135,000-square-foot corporate facility in DFW Airport, Texas, features over 100,000 square feet of manufacturing space. Our goal is to produce high-quality, commercial-grade machinery at reasonable prices. So as a manufacturer of precision CNC machinery, we reinvest a significant portion of our profits into automating our own factory.

At MultiCam, our engineering staff designs all products in house using SolidWorks 3-D modeling software.

FEA (Finite Element Analysis) software allows our engineers to simulate structural machine loads so we can design appropriate safety factors into each area of every CNC cutting machine.



We manufacture all machine control systems to NEC standards. MultiCam platforms feature major name-brand components that are either UL listed or recognized, and we are CE certified to ship to Europe.

MultiCam stocks steel in 12-meter lengths. We order steel in full truckloads to help reduce costs and control lead times.





# Engineering Advancements

Using precision band saws, we cut steel tubes and bar stock to length.



MultiCam processes aluminum extrusions with a custom-built MultiCam CNC router.

A Motoman six-axis welding robot mounted on a CNC-controlled MultiCam 20-foot slider mechanism seam welds frames.



Our MultiCam 3000 Series HyPerformance Plasma system cuts plate steel that we process on our precision CNC press brake.





# MultiCam Factory Tour



Before machining frames, we stress relieve them for sturdy reliability. Then we use a Uniport 6000 to process both frames and gantries. It has a work envelope of 40' (X), 10' (Y) and 4' (Z) and is capable of machining tolerances of  $\pm 0.0005$ ".

MultiCam machines most small components on high-tolerance Cincinnati Milacron vertical machining centers.



For multi-sided machining of critical gantry support and Z-axis castings, we use a Giddings & Lewis horizontal machining center.



To be environmentally friendly, MultiCam applies low-VOC, high-solid paints with HVLP systems.





# Quality Assurance

The MultiCam factory has approximately 30 machines in various stages of assembly at any given time.



To ensure the high quality and accuracy of your machine, our Quality Control Department inspects every MultiCam thoroughly and signs off on it.



Our multi-million-dollar inventory helps reduce lead times and ensures minimal downtime for service and support issues.



We shrinkwrap each machine with heavy-duty, 10-mil industrial plastic to ensure that moisture won't harm it during shipping. MultiCam's interior truck well protects your cutting table from weather when we load it for transport.







# Choose a Router for Versatile Performance

MultiCam manufactures popular space-saving moving-gantry and moving-table CNC routers. Each series comes in multiple sizes that we can outfit with the appropriate options to meet your specific requirements. Options include high-frequency spindles, tool changers, gang drills, vacuum tables, aggregate heads, saws, knives and many more.

## Classic Series Router High Performance at an Entry-Level Price

This basic machine offers a price/performance breakthrough in CNC router design. The rigid, reliable Classic combines simplicity and functionality in an inexpensive cutting system. It features a high-speed three-axis motion controller. The Classic is the perfect solution for sign manufacturing and applications requiring value, efficiency and affordability.



HP:	3 hp
Table Sizes:	50" x 50" to 80" x 120"
Rapid Traverse:	850 IPM
Repeatability:	± 0.001"
Weight:	1200-2000 pounds



Precision arts and crafts

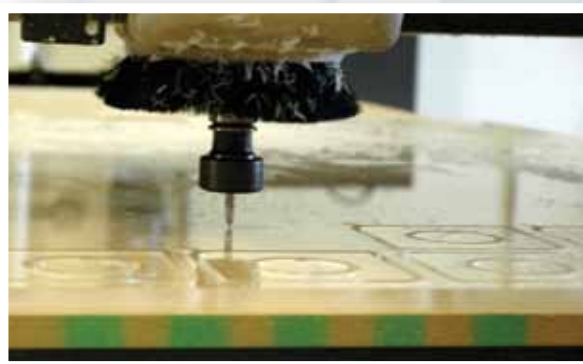

1000 Series Router cuts 1/2" acrylic

## Applications

- 3-D Carving
- Acrylic Fabrication
- Aluminum Fabrication
- Architectural Millwork
- Aerospace
- Cabinetry
- Exhibits and Fixtures
- Signmaking
- Arts and Crafts
- Furniture
- Boat Building
- Musical Instruments



3000 Series Router cuts small aluminum parts





### 1000 Series Router Maximum Flexibility Made Affordable

If you need an entry-level, moving-gantry-design CNC router, select the 1000 Series. Its custom-engineered, extruded-aluminum gantry provides a rigid assembly that can carry multiple cutting options while delivering clean, smooth edge quality. The 1000 Series with steel base provides a strong, stable routing platform at a very affordable price.



HP Range:	4-5 hp
Table Sizes:	50" x 50" to 80" x 241"
Rapid Traverse:	850 IPM
Repeatability:	± 0.001"
Weight:	2500-4600 pounds



3-D carving of 3/4" MDF with 3000 Series Router

**“The best thing I ever did was buy a MultiCam. It’s very easy to use and does the work of four people.”**

— Terry Bodeker, Plex-Appeal Inc. part owner

### 3000 Series Router Versatile, Feature-Rich Production

Our 3000 Series moving-gantry-design router is a popular choice among small- to medium-sized manufacturers demanding a powerful yet affordable machine. It features a rigid steel gantry and frame. Capable of processing a unit of material in an eight-hour shift, the 3000 Series CNC Router is a powerhouse designed for the intermediate budget.



HP Range:	5.5-13 hp
Table Sizes:	50" x 50" to 80" x 241"
Rapid Traverse:	2500 IPM
Repeatability:	± 0.001"
Weight:	3000-8000 pounds



## 5000 Series Router

*Rugged, Reliable and Built to Last*

Are you in the market for a heavy-duty large-format CNC router? The MultiCam 5000 Series moving-gantry machine comes in table widths up to 120" and standard lengths up to 600". We'll also quote custom sizes to fit your specific needs. If you're looking for a large CNC routing platform, the MultiCam 5000 Series is an excellent choice.



HP Range:	5.5-20 hp
Table Sizes:	50" x 50" to 120" x 600"
Rapid Traverse:	2700 IPM
Repeatability:	± 0.001"
Weight:	5000-20,000 + pounds

### 5000 Series Router cuts 3/4" plywood

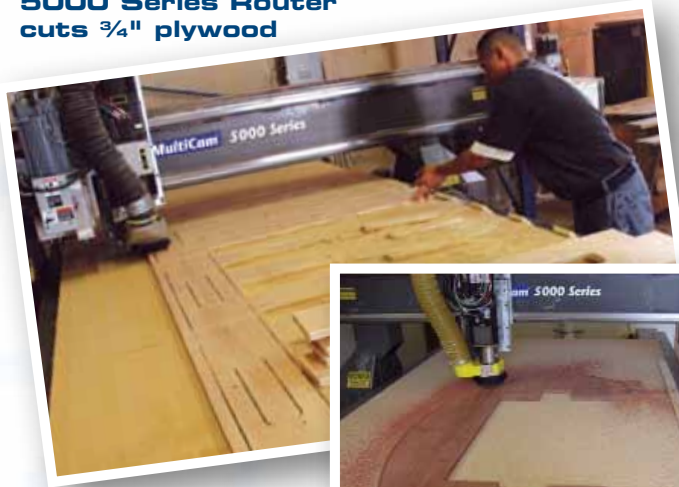

**Solid wood stair components**

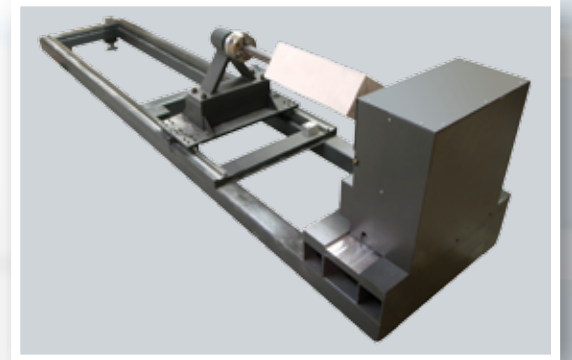

### Optional Router Lathe

MultiCam software wraps a CAD file around a part automatically, and the optional lathe rotates the part for routing.

### Materials Cut

- Acrylic
- ACM
- Copper
- Brass
- Aluminum
- PVC
- Foam
- MDF
- Melamine
- Phenolic
- Plywood
- HDPE
- Solid Surface
- Solid Wood



**Aggregate tooling offers machining flexibility**





### 7000 Series Router The Ultimate in Heavy-Duty High Performance

For the most powerful moving-gantry-design machine, check out the 7000 Series Router. We can configure it with up to four independent Z-axis carriages or heavy-duty spindles and drill banks for multifunction panel processing.

HP Range:	5.5-20 hp
Table Sizes:	60" x 60" to 120" x 600"
Rapid Traverse:	3000 IPM
Repeatability:	± 0.001"
Weight:	6000-30,000 + pounds



Beveled-aluminum part cut at high speed on 7000 Series Router

**“The MultiCam Router’s extra capabilities and speed increased my business and revenue by 33% in the first six weeks.”**  
— Tony Woodall, AST Waterjet owner



### 7000 Series XD Router Auto Load/Unload Capabilities

Looking for an affordably priced, high-production CNC router? The MultiCam 7000 Series XD is the answer.

We designed it for flat-sheet panel-processing applications that demand high-speed automatic load/unload capabilities.

A roller hold-down option is available for simultaneous multiple-sheet processing.

HP Range:	11-20 hp
Table Sizes:	60" x 120" to 80" x 169"
Rapid Traverse:	3000 IPM
Repeatability:	± 0.001"
Weight:	8000-16,000 pounds



## 8000 Series Five-Axis Router The Ultimate Heavy-Duty Workhorse

MultiCam's versatile 8000 Series is the ultimate high-performance CNC machining solution for high-speed, heavy-duty routing. This Five-Axis Router features standard X, Y and Z axes plus a rotational C axis and a swing A axis. The extremely flexible 8000 Series Router can machine in all five axes simultaneously or rotate around a part, machining on all five accessible surfaces.



HP Range:	10-20 hp
Table Sizes:	5' x 5' to 10' x 30'
Rapid Traverse:	2700 IPM
Repeatability:	± 0.001"
Weight:	10,000-20,000 pounds



Thermoformed plastic parts

### Many Five-Axis Applications

Five-axis CNC routing expands the end user's capabilities and flexibility. It's ideal for edge trimming thermoformed and molded plastic plus composite parts. Other applications include deep-cavity mold making that calls for short tools. Molded plywood chair and decorative furniture parts require simultaneous five-axis machining many times.



Molded plywood furniture

### Materials Cut

- Carbon Composite
- Delrin
- Fiberglass
- Honeycomb Material
- Lexan
- Polycarbonate
- Titanium
- Polypropylene
- Zinc
- Polyurethane
- Precision Board
- Rubber



Composite wind turbine parts



Structural aluminum components





## **MT Series Router** *Popular for Demanding Applications*

Our MT Series CNC Router features a fixed gantry and moving table. This separates the X-axis motion from the Y and Z axes. Precision ball screws drive the X and Z axes, and a precision-ground rack powers the Y axis. The inherent rigidity and precision of the moving-table design make the MT a popular choice for demanding applications.



HP Range:	5.5-20 hp
Table Sizes:	25" x 25" to 80" x 145"
Rapid Traverse:	2100 IPM
Repeatability:	± 0.001"
Weight:	2600-10,000 pounds

## **Custom CNC Routers** *Designed to Fit Your Specific Needs*

We custom manufacture MultiCam CNC machines to your unique manufacturing requirements. Do you need a machine with an 80' table? How about two gantries? Six spindles? A rotary table? Custom paint scheme? We've built all of these variants for customers in the past, and our innovative design team can custom-tailor a machine to fit your needs.



If you're looking for a custom machine, please contact your local MultiCam Technology Center for an evaluation of your application.

MultiCam offers the right high-speed, high-accuracy cutting solution in a size to fit your company's needs.



**Custom 5000 Series Router has an 8' x 50' capacity**



# Power Your Creativity with a Digital Finishing System

## Digital Express

*High-Speed Digital Finishing at 7000 Inches per Minute*

The fastest production machine on the market, the affordable Digital Express represents a major breakthrough in productivity. Use this versatile, configurable platform for high-speed digital finishing at speeds up to 7000 inches per minute. A wide-format, sheet-fed or conveyorized cutting platform, the Digital Express combines high-speed digital registration with powerful routing and knife-cutting capabilities.



HP Range:	3-4 hp
Table Sizes:	50" x 50" to 120" x 289"
Rapid Traverse:	7000 IPM
Repeatability:	± 0.001"
Weight:	3000-10,000 pounds

**“In terms of speed, the Digital Express has been a game changer. It’s 10 times as fast as hand cutting. We’ve saved on labor by needing just one person instead of five.”**

— Ron Freeman, Store Decor General Manager

## Graph-X-Cutter™

*Affordable, High-Speed Digital Finishing System*

With a maximum cutting speed of 1000 inches per minute, the Graph-X-Cutter™ also delivers 2100-IPM maximum rapid traverse. This fully equipped cutter features both high-speed routing and heavy-duty tangential knife-cutting capabilities. An integrated phenolic vacuum table is standard, and the optional MultiVision™ digital registration system auto corrects image skew and drift.



HP:	1.5 hp
Table Sizes:	50" x 50" to 80" x 120"
Rapid Traverse:	2100 IPM
Repeatability:	± 0.001"
Weight:	1200-2000 pounds





**Optional MultiVision Digital Registration**

### **MultiVision™ Digital Registration System** *Auto Corrects Image Skew and Drift*

A digital camera/software-based system, MultiVision™ recognizes media registration marks visually and aligns the image automatically. It integrates easily into your existing workflow while providing the additional flexibility of utilizing state-of-the-art CAD/CAM software for enhanced tool-path generation as well as advanced 3-D sign and graphics applications.

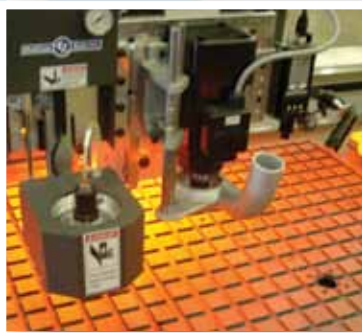

### **MultiCam EZ Knife® System** *Stand-Alone Machine Also Enhances Many Platforms*

We developed the MultiCam EZ Knife® system to serve markets that require mechanized knife-cutting, creasing and perforation operations. The tangential system supports rotary, kiss-cut, drag, oscillating and ultrasonic cutting technologies. EZ Knife comes standard on the Digital Express and Graph-X-Cutter. Also use it as a stand-alone machine or as a router and plasma option.

## **Register, Route and Knife Cut — All on One Machine!**



**1000 Series Digital Finishing System with MultiVision, EZ Knife and 4-hp router**



- Materials Cut**
- Cardboard
  - Carpet
  - Foam
  - Fabric
  - Foamcore
  - Corrugated Plastic
  - Acrylic
  - Wood
  - Leather
  - Pre-Preg

- Applications**
- Sign and Graphics
  - Digital Printing
  - Packaging
  - Automotive
  - Aerospace
  - And More

# Pick a Plasma for Smooth, Clean Cuts

Imagine the high torque and lateral stress that router cutting generates. Applying the same principles we've learned over time to plasma cutting produces an amazingly smooth, clean cut. MultiCam innovations in CNC plasma systems start with the EZ Control material library. EZ Control sets all cut parameters automatically, yielding highly consistent cut quality.

## V-Series Plasma Versatile Low-Cost Performance

The Value-Series Plasma is the choice for maximum value and performance to cut mild steel, stainless steel and aluminum. This affordable cutting solution features Hypertherm PowerMax™ plasma cutting torch technology. Included EZ G-Code software allows V-Series Plasma operators to program complex shapes and configurations quickly.



Plasma Units:	Hypertherm
Table Sizes:	50" x 50" to 80" x 120"
Rapid Traverse:	1200 IPM
Repeatability:	± 0.001"
Weight:	1200-2000 pounds



**V-Series Plasma cutting mild steel**



**EZ G-Code  
shape library**



**3/4" mild-steel  
plasma-cut part**



**Cutting 1/2" plate steel with the  
3000 Series Plasma and HPR 130**

## Applications

- Machine Manufacturing
- Armored Vehicles
- Automotive Fabrication
- Construction
- Decorative Fencing
- Job Shops
- Structural Steel
- Marine Fabrication
- Oil Field Equipment
- Sign Shops
- Metal Fabrication
- HVAC

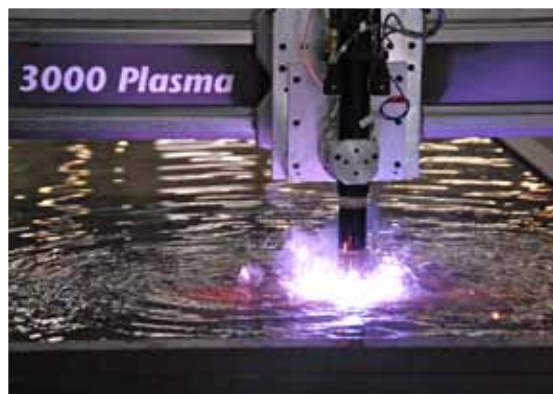

**3000 Series Plasma  
with optional water table**





**1000 Series Plasma**  
*Rigid, Reliable Value*

A conventional CNC plasma system, the cost-conscious 1000 Series is ideal for HVAC applications. It features a heavy, all-steel-plate frame base. We can equip it for light- to medium-duty plate cutting.

Plasma Units:	Hypertherm
Table Sizes:	50" x 50" to 80" x 241"
Rapid Traverse:	850 IPM
Repeatability:	± 0.001"
Weight:	2500-8000 pounds



**Optional Knife Cutter**

With MultiCam's EZ Knife option, the same machine cuts fiberglass and closed-cell foam insulation with ease.

**“The MultiCam Plasma is the finest made machine. It provides the versatility of two heads, high definition and parts requiring no cleanup.”**  
— Terry Clements, M&M Manufacturing plant manager



**3000 Series Plasma**  
*Precision Firepower*

Our popular MultiCam 3000 Series Plasma is the perfect choice for shops needing value, versatility and firepower. Optional zoned downdraft tables and convenient pull-out cross drawers make fume extraction and cleanup a snap. Cut both sheet metal and plate steel with virtually dross-free results.

Plasma Units:	Hypertherm
Table Sizes:	50" x 50" to 96" x 289"
Rapid Traverse:	2500 IPM
Repeatability:	± 0.001"
Weight:	3000-10,000 pounds

### 1000 Series Bridge and Rail Plasma/Oxy-Fuel Modular, Versatile and Cost Effective

We designed the 1000 Series Bridge and Rail for the customer who desires modularity, versatility and a wide range of working envelopes. It's an excellent choice for the entry-level manufacturer or any shop looking for an economical way to cut plate steel and aluminum.



Plasma Units:	Hypertherm
Width:	6'-12'
Length:	12'-30' +
Rapid Traverse:	850 IPM
Repeatability:	± 0.001"
Weight:	2000-7000 pounds

### 6000 Series Bridge and Rail Plasma/Oxy-Fuel Heavy-Duty High Performance

For large-format, heavy-duty jobs, the MultiCam 6000 Series Plasma is the product of choice. We designed it for manufacturers who need to cut heavy plate steel and want a large process area without sacrificing accuracy and quality.



Plasma Units:	Hypertherm
Width:	8'-20'
Length:	5'-100' +
Rapid Traverse:	1400 IPM
Repeatability:	± 0.001"
Weight:	5000-20,000 pounds +

### Featuring **Hypertherm** Torches

MultiCam is proud to partner exclusively with Hypertherm®, the global leader in plasma cutting torches. Its True Hole™ technology creates perfectly round holes with exceptional edge quality and reduced bevel or taper.







**3000 Series Plasma with CNC interface and rotary indexer options**



**Optional Five-Axis Plasma head allows 3-D bevel cutting**



**6000 Series Plasma with six-head oxy-fuel system**

### **Materials Cut**

- Steel
- Stainless Steel
- Aluminum
- Brass
- Bronze
- Copper
- Diamond Plate
- Expanded Metal
- Galvanized
- And More



**6000 Series Plasma with HPR 260 cuts 5/8" plate steel**



**Decorative sheet-steel parts**

# Select a WaterJet for the Most Versatile MultiCam Platform

High-pressure MultiCam WaterJet machining systems offer unique advantages over other cutting technologies. When combined with our EZ Control system, waterjets are able to cut virtually any material with a high degree of accuracy and without heat. The MultiCam WaterJet line comes in three strategic frame styles — all powered by KMT high-pressure waterjet intensifiers. MultiCam is proud to partner exclusively with KMT, the global leader in waterjet cutting technology.

## V-Series WaterJet Flexible Yet Economical Performer

The Value-Series WaterJet is a smart CNC investment that's easy on the budget. We designed this pure-water or abrasive cutting system to make high performance, versatility and productivity affordable. KMT's NEOLine™ 10-hp direct-drive or 40-hp high-pressure intensifier powers the V-Series WaterJet.



*Our V-Series WaterJet and direct-drive pump can run on 220-V single-phase power*

WaterJet Units:	KMT
Table Sizes:	60" x 60" to 80" x 120"
Rapid Traverse:	1100 IPM
Repeatability:	± 0.001"
Weight:	3700 pounds empty 13,600 pounds with water

**“We’re spoiled since we added the MultiCam WaterJet. It’s a very good product that produces parts requiring little cleanup.”**

— Keith Boyd, North Texas Pressure Vessels part owner

## 3000 Series WaterJet Affordable Robust Precision

MultiCam's 3000 Series WaterJet cutting system is an affordable, easy-to-use production cutting solution designed for manufacturers who want the ability to cut a wide variety of materials. Available in both pure-water and abrasive configurations, each 3000 Series WaterJet comes standard with MultiCam's advanced graphical CNC interface and NC GeoMate programming software.



WaterJet Units:	KMT
Table Sizes:	60" x 60" to 80" x 192"
Rapid Traverse:	2100 IPM
Repeatability:	± 0.001"
Weight:	5700 pounds empty 15,600 pounds with water





**MultiFeeder abrasive feeder/bulk hopper system operates under full CNC program control**



**Non-abrasive waterjet cuts vinyl for athletic jerseys**

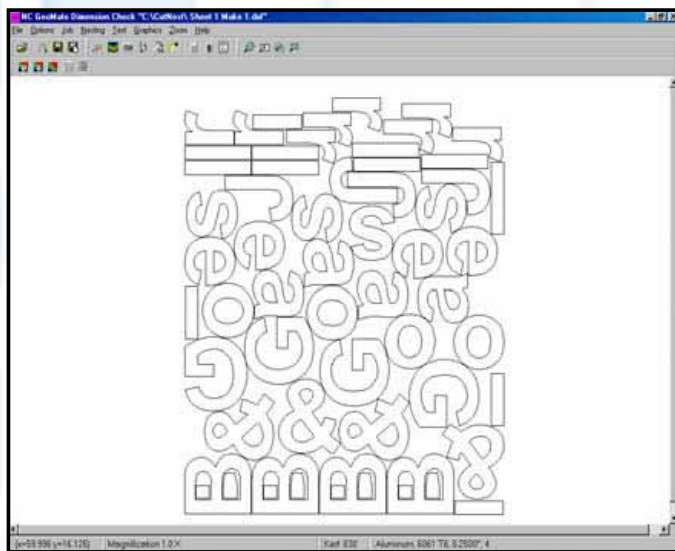

**NC GeoMate™ Programming Software**

This software was developed specifically for CNC waterjet systems. Unlike conventional CAM programs designed for general metalworking applications, NC GeoMate™ is fully optimized to the demands of waterjet cutting.

**Applications**

- Aerospace
- Metal Fabrication
- Glass/Ceramics
- Boat Building
- Countertops
- Fiberglass
- Gaskets/Seals
- Job Shops
- Ornamental Metal
- Prototyping
- Signmaking
- Textiles
- Vehicle Customization
- And More



**Advanced graphical CNC interface**

**6000 Series WaterJet**  
**Heavy-Duty Powerhouse**

The MultiCam 6000 Series CNC WaterJet raises the bar for manufacturing excellence. When the job calls for a large work envelope, power and flexibility, the 6000 Series WaterJet is the system of choice.



WaterJet Units:	KMT
Table Sizes:	120" x 60" to 144" x 481"
Rapid Traverse:	1400 IPM
Repeatability:	± 0.001"
Weight:	5000-20,000 pounds +



**Featuring  Pumps**

**KMT Waterjet Pumps**

Since 1971, KMT Waterjet Systems has been a global leader in waterjet technology. Manufactured in the USA with global service and support, these precision-engineered pumps are highly efficient and extremely reliable. MultiCam is proud to offer a full spectrum of KMT intensifiers from the NEOLine™ Series for economical system integration to 90,000-PSI Streamline PRO series pumps' massive power and maximum cutting speed. Please contact your local MultiCam Technology Center for specific information and recommendations. MultiCam also will work with you to integrate our line of waterjet machines with existing pump technology you may have already.





**WaterJet-cut precision aluminum part**

## Materials Cut

- Steel
- Stainless Steel
- Aluminum
- Brass
- Copper
- Titanium
- Concrete/Cement
- Stone
- Granite
- Marble
- Rubber
- Plastics
- Vinyl
- And More



**Architectural fascia cut on 3000 Series WaterJet**



**WaterJet cuts 3/4" granite**



# Enlist a Laser for Polished Edge Finish

## 2000 Series Laser

*Speed That's Affordable Yet Precise*

Cutting with a 0.005" beam of light is the latest technology MultiCam has brought to market! It also takes advantage of the EZ Control system MultiCam has refined since 1989. The 2000 Series is an extremely versatile and affordable laser system.

Able to raster engrave and vector cut in one CNC process, the 2000 Series is perfect for cutting a wide variety of materials including plastic, wood and light-gauge ferrous metals. When machining acrylic, the laser cuts and polishes the edge in the same pass, eliminating secondary operations and saving valuable production time.



Laser:	100-600 W
Table Sizes:	60" x 50" to 80" x 241"
Rapid Traverse:	2500 IPM
Repeatability:	± 0.001"
Weight:	6000-15,000 pounds

**“The laser is awesome. It lines up perfectly, holds the registration, speeds up production and cuts out several manual procedures.”**

— Dave Brown, ASI Signage Innovations production manager

### Applications

- Vector Cutting
- Raster Engraving
- Nameplates
- Signmaking
- Control Panels
- Displays
- Polished-Edge Acrylic Fabrication
- Sheet-Metal Fabrication



**Raster engraving**



**Laser-cut acrylic part**



**400-watt 2000 Series Laser cutting gauge steel**

All MultiCam Inc. laser cutting machines conform to the Laser Radiation safety codes per US 21CFR1040.10/11 except for variations of laser notice No. 50 (07-2001). MultiCam takes great pride and care in assuring complete safety of our customers and staff. For more information, please contact MultiCam at [info@multicam.com](mailto:info@multicam.com) or call 800-991-4225.





# Use a Robot Slider for Specialized Applications

MultiCam's Robot Slider offers a new level of functionality and affordability in the rough robotic welding environment. It's also ideal for high-speed, high-velocity, medium-duty pick-and-place applications and painting. At 14" tall along the track, the sleek, low-profile system is easy to step across. The robot track features a precision-ground helical rack. Its 35-mm linear guide rails support multiple trolleys up to 2 meters long and 10,000 pounds of equipment.

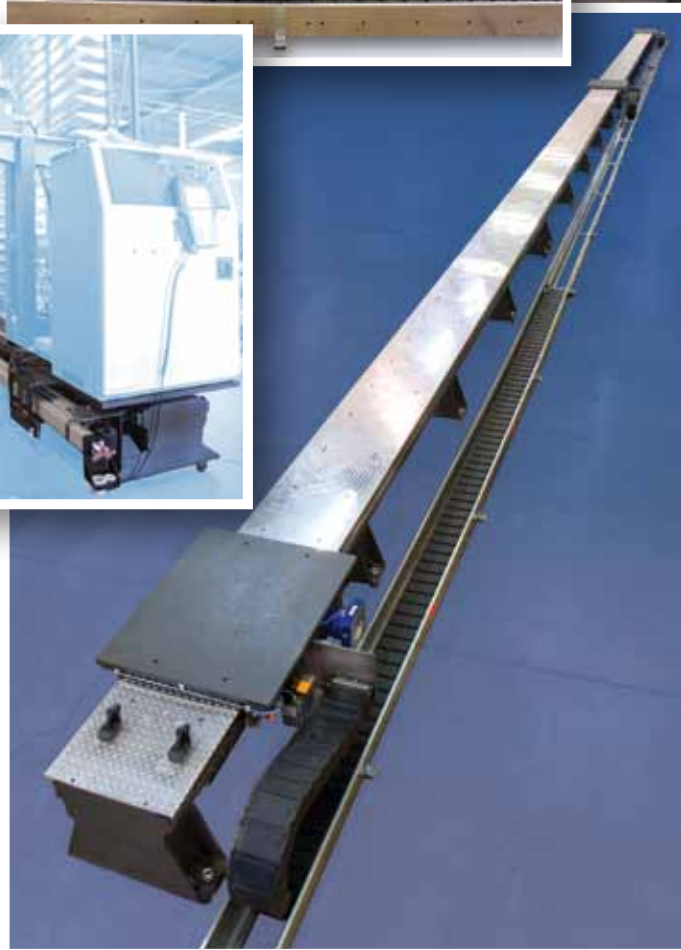

## Standard Features

- 35-mm precision linear guide rails
- Module 3 precision-ground helical rack
- Protective covers for rack and linear rail
- Alpha 10:1 precision planetary gearbox
  - Very low backlash
  - Lifetime lubricated
  - Ultra quiet
- Igus 400 Series quiet E-Chain
- Welded, stress-relieved and precision-machined frame
- Integrated lifting eyes
- Heavy-duty mechanical safety stops
- Integrated over-travel-limit switches
- Modular design allows for extended lengths

# Customer Applications

## **MultiCam Router Increased Plex-Appeal's Speed and Quality**

Since buying a MultiCam 3000 Series Router, Plex-Appeal Inc. broadened its custom acrylic fabrication capabilities. It cuts various shapes in one easy setup, saving time over multiple passes. Customers like the fine edge finish this versatile machine creates.

"With the MultiCam Router, we can take any piece of plastic and turn it into anything a customer can imagine," part owner Terry Bodeker said. "The machine paid for itself by eliminating a lot of handmade templates. It's made a huge difference by saving time and improving quality."

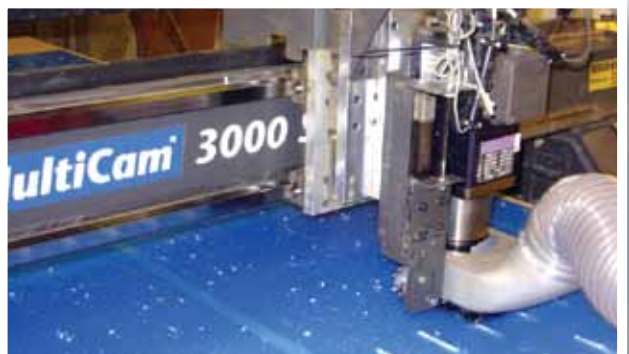

**Plex-Appeal's MultiCam Router features a 5.5-hp, 32,000-rpm spindle with automatic tool changer.**

## **Router Expanded AST Waterjet's Capabilities**

To broaden AST Waterjet's cutting capabilities, the job shop added a MultiCam 7000 Series Router, which expanded its business. The router cuts sheet metal faster, more efficiently and with a higher precision edge quality than a waterjet. Plus it processes virtually any material. Its aluminum and copper parts with machined edges amaze customers.



**AST cuts thousands of pounds of nested aluminum and copper parts with its MultiCam Router.**

"I bought the router because I was missing out on opportunities," owner Tony Woodall said. "Now I can lower bids and machine materials most shops can't. The MultiCam Router is more advanced and easier to use than competitive systems."

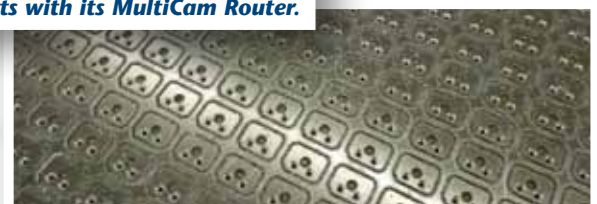

**Cutting aluminum parts with internal countersunk holes is easy with the MultiCam Router.**

## **Digital Express Speeds Store Decor's Creativity**

Store Decor bought a MultiCam High-Speed Digital Express to make its retail graphics business even more creative. By eliminating time-consuming hand cutting and manual registration, it's speeding and expanding the digital finishing process.

"The Digital Express eliminated hand cutting that was a nightmare," General Manager Ron Freeman said. "Accessing all files in the EZ Control provides ease of use and saves time. Now everything comes out exactly right. The Digital Express has opened up a whole new avenue of business."



**Featuring MultiVision digital registration, the Digital Express provides quick, accurate alignment.**



**Cutting sign lettering is fast with the Digital Express.**



## **Plasma Improved M&M Manufacturing's Output**

M&M Manufacturing Company's MultiCam 3000 Series Plasma increased its output immediately. The HVAC shop runs the machine hard 55 hours a week to manufacture ventilation systems. Its timesaving pendulum-processing feature cuts one sheet while the operator loads another, so the machine never stops producing.

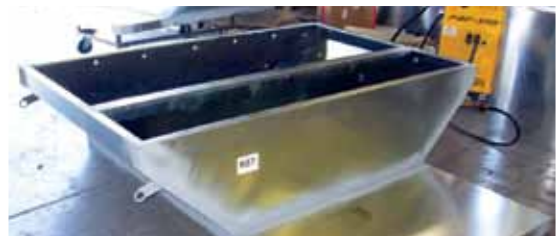

**To make commercial and industrial HVAC roof curb adapters, M&M assembles sheet metal parts.**



**The MultiCam Plasma produces a clean, smooth, dross-free cut.**

"With the HD torch, parts are ready to roll and weld," Plant Manager Terry Clements said. "The smooth finished edge saves a step. It gets rid of the razor-blade-like slag, so we don't have to clean it."

## **MultiCam WaterJet Helped NTPV Grow**

Thanks to the MultiCam 3000 Series WaterJet, North Texas Pressure Vessels Inc. is a growing one-stop shop that does its own machining in house. The company makes steel and aluminum parts for oil and gas pressure vessels. By producing better-looking, higher-quality parts, the business is more competitive and expanding into a larger facility.



**NTPV's MultiCam 3000 Series WaterJet features a 60" x 144" work surface.**

"We cut parts with no cleanup required," part owner Keith Boyd said, "so the MultiCam WaterJet paid for itself by saving time. It has taken NTPV to the next level. Now we can do it all including artistic work for sign companies."

## **Laser Streamlined ASI's Sign Production**

A MultiCam 2000 Series CNC Laser streamlined ASI Signage Innovations' high-end architectural sign production. Automation allowed employees to cut out a number of manual steps, saving time and money. With the MultiCam Laser delivering a clean, polished edge, they've eliminated painstaking hand finishing.

"Accuracy is spot on," Vice President Fred Wilson said. "We have more control and better profit margins. The MultiCam Laser paid for itself in ROI in about a year. We're significantly more competitive in the sign market now."

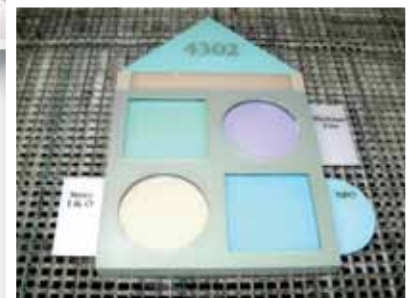

**ASI sandwiches layers together between face plate and back plate to create hospital room signs.**

# ▶ CNC Cutting Solutions

Many Platforms. Infinite Applications.

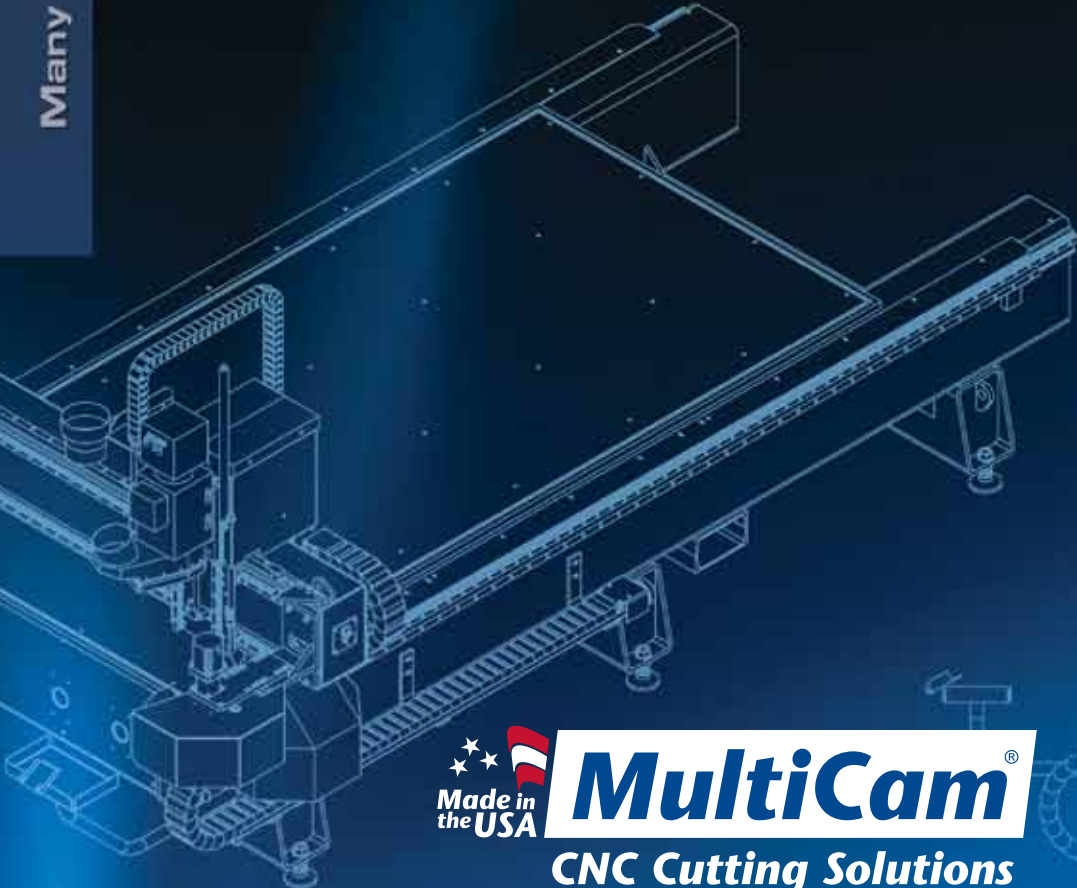
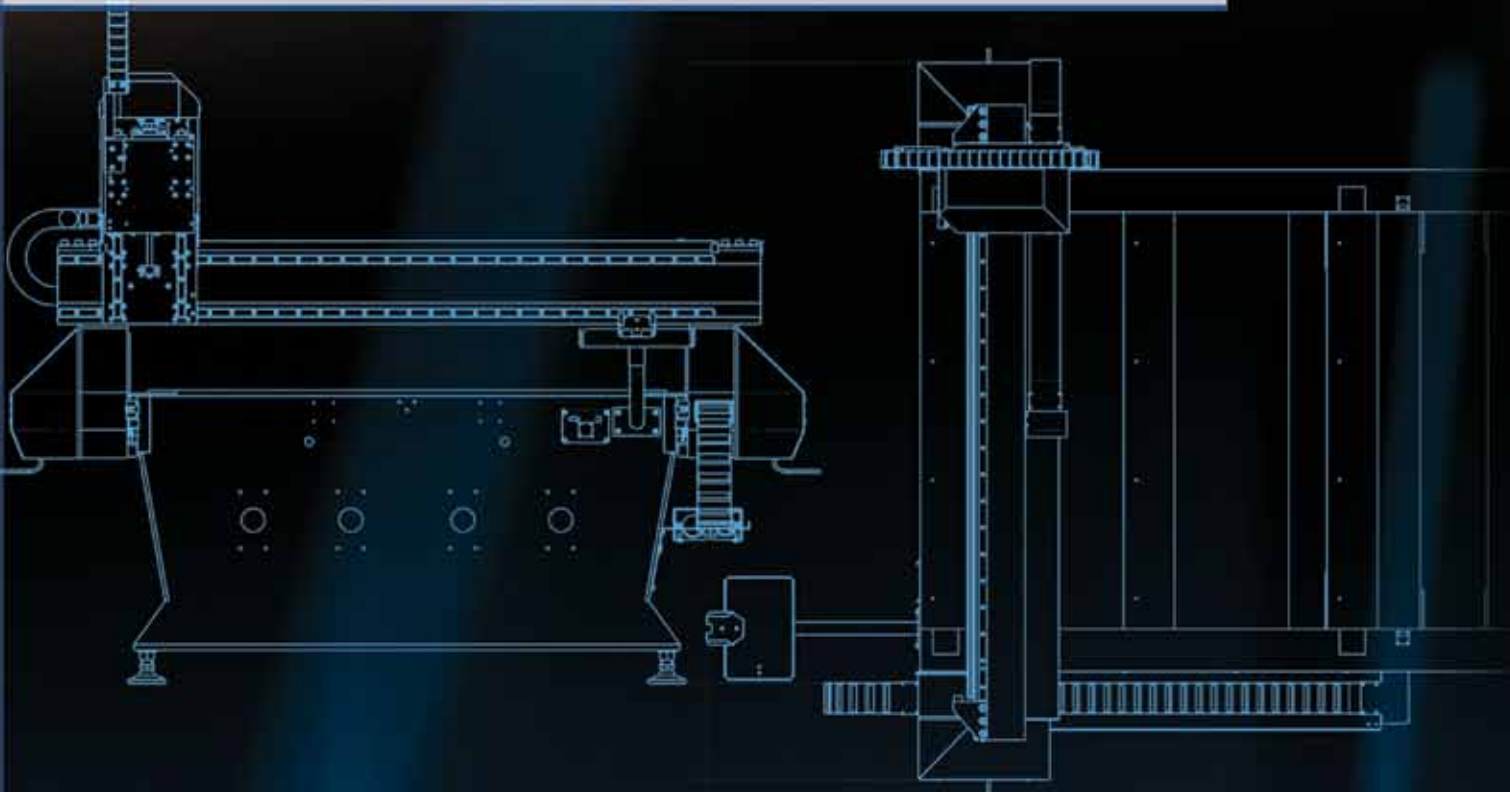

**Made in the USA**  **MultiCam**<sup>®</sup>  
**CNC Cutting Solutions**



**AHB** Tooling & Machinery, Inc.  
Complete Metalworking Solutions  
Roseville Saginaw & Jackson, MI

ISO Certified  
(800) 991-4225  
[www.ahbinc.com](http://www.ahbinc.com)  
[customerservice@ahbinc.com](mailto:customerservice@ahbinc.com)