

MultiCam[®]

CNC Cutting Solutions

Features & Specifications Guide for MultiCam 6000 Series CNC Plasma

Rugged, Heavy-Duty... ...High Performance!

Designed for manufacturers who need to cut heavy plate or need a large processing area without sacrificing accuracy or cut quality. The 6000 Series motion platform is independent of the cutting surface helping to insure that the motion platform will not be damaged from material loading or from the high heat of oxyfuel cutting. Available widths are from 8'-20', with lengths starting at 12'. Add additional 10' sections to make the 6000 system the perfect complement to your production facility. With a rapid traverse speed of 1000 ipm, the rigid, heavy, all-steel construction combined with precision guide ways makes this system one of the most accurate heavy cutting systems on the market today.



MultiCam, Inc.
1025 West Royal Lane
DFW Airport, Texas 75261
972.929.4070 • fax 972.929.4071
www.multicam.com • sales@multicam.com

All specifications subject to change.
© 2008 MultiCam, Inc. All Rights Reserved.

Innovation. Quality. Performance.

6000 Series Specifications

No machine offers more standard features than the MultiCam.

- High-Speed contouring
- Fully programmable retract between parts.
- Automatic initial pierce height
- User-friendly MultiCam Controller
- Material Database
- Modular X-axis beams are made from heavy tubing with machined bearing references
- Ground roller ways with integrated rack and wipers
- Gantry has front mounted linear bearing and robust rack drive
- Capable of carrying several different process' such as: Ox-fuel, Plasma, Hy Definition Plasma, Scribe, Drill & Tap, and Electrospindle
- Stress-relieved heavy duty all steel construction.
- 12 Megabytes of Memory with unlimited file size transfer capabilities
- Standard Ethernet communications
- Single carriage can support Oxy-fuel and Plasma with torch height control



Integrated Material Database

Normally when you change material type, material thickness, or arc current, many parameters such as feedrate, pierce delay, pierce height, etc. all need to be adjusted. MultiCam has made this process simple by integrating all of these cutting values into an easy-to-use menu driven database on our hand held controller. The user simply selects material type, thickness, and arc current and all of the settings are adjusted automatically.



Modular Base Rails

The MultiCam 6000 Series modular base rails are made from 1/2" thick 8" x 12" tubular steel. 1" by 1.5" steel bars are welded to the steel tubes, stress relieved, and then precision machined. This extremely ridged base reduces vibration and allows for the best cutting quality. 5 foot and 10 foot modular sections can be added for long machine lengths.

Dual X axis – ground roller ways, Rack and Pinion, AC Brushless Servos, and Gudel Gearboxes

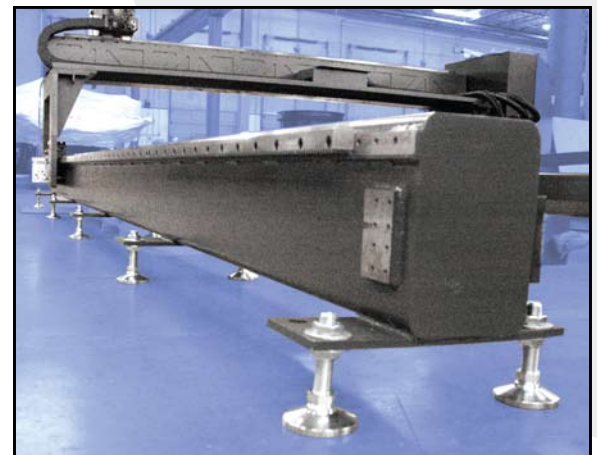

Gantry

The gantry is made of a 1/4" thick 12" square tubular steel and reinforced by 1/4 thick structural steel that is welded, stress-relieved, and precision machined. The gantry has been engineered to provide a smooth, vibration free cut and FEA (Finite Element Analysis) was used to insure minimum deflection over wide spans.

Y axis – 25mm Linear Rails, AC Brushless Servos, Precision Planetary Gearboxes, and Rack and Pinion

Gantry Supports

The 6000 Series gantry supports are manufactured from 1.5" thick flame cut steel plate. They are welded, stress-relieved, and precision machined. Wide X axis bearing spacing and heavy plate help dampen vibration and give the structural tube gantry extremely rigid support.

Feed

- Cutting Speed: 800 ipm
- Rapid Traverse (X and Y) 1800ipm

Precision Worm GearBoxes (X-Axis)

We use high performance worm gearboxes especially developed for use in high performance Servo-Driven Systems. The backlash is adjustable to zero and is set by rotating the two eccentric flanges located on either side of the gearbox housing. These high torque, low backlash, gearboxes are ideal for positioning the heavy gantry at high speeds and high acceleration rates without sacrificing smooth motion.

- Single Stage 24:1
- Backlash < 3 arcmin
- Low Noise Level

Regulator Units

Machines equipped with tool changing spindles come standard with SMC filter regulator units that also include an ambient air drier.

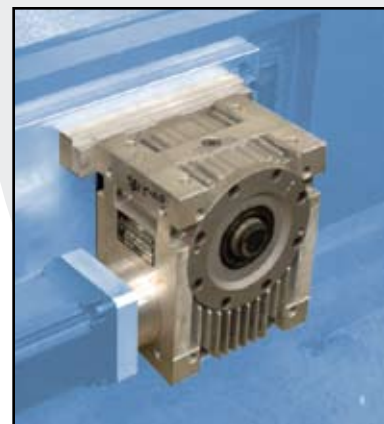

6000 Series Specifications

Precision Planetary Gearboxes

Alpha Precision Planetary Gearboxes are the top of the line in the industry. Case hardened and finished ground high carbon alloy steel gears guarantee the lowest backlash and highest service life available. Alpha Gearboxes are one of the many components that make the MultiCam a smooth, accurate, and long-lasting cutting system.

- Single Stage 10:1
- Backlash < 2 arcmin
- Efficiency > 97%
- Low noise level
- Integrated thermal length compensation
- Designed for cyclic and continuous 100% duty cycle operation
- 5-Year Manufacturer Warranty



Linear Bearings (Y and Z-Axis)

25 mm Star ball linear bearing profile rails with stainless spring steel strip cover

- High rigidity and load capacities in all load directions.
- Lowest possible noise level and best running characteristics.
- High torque load capacity
- 4 bearing packs per axis

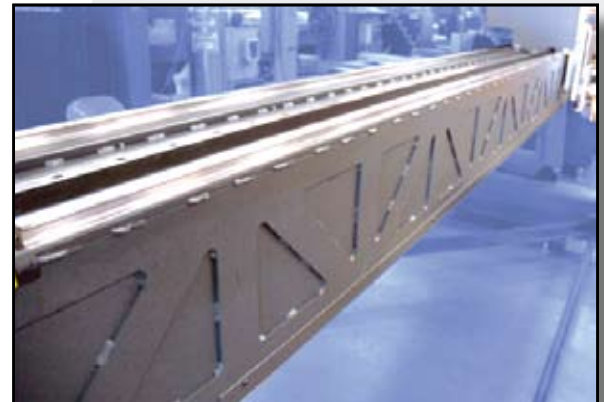

Guide Way System (X-Axis)

The 35 mm Güdel precision linear guideway system is used on the modular base rails of the 6000 series machine. The rollers are manufactured in the PN tolerance class as dual-row angular contact ball-bearings with a pressure angle of 25° with RSR sealing washers on both sides, and a lifetime grease packing.

- The guiding surfaces are hardened 60-62HRC
- Lifetime grease packing on bearings
- Integrated precision hardened and ground rack
- Wheel covers incorporate high-pressure oil fittings for ease of maintenance



Digital Servo Drives

Teknic's SSt Eclipse E750 digital servo drives are high-bandwidth, digital vector servo drive systems and are standard on all 6000 Series machines. These drives seamlessly integrate position, velocity, and torque loops to provide uncompromised tracking accuracy, smoothness and reliability. The Eclipse drives used in MultiCam servo-driven machines are the latest in a line of high-performance drives that advances the state of the art by utilizing this seamless coordination in such a way to allow all information to be shared in real time so all system functions cooperate in any situation. For example, if the torque loop senses that the motor has reached 100% torque output, it is instantly passed upstream to the servo compensator and the system delivers a coordinated response, maintaining precise control. You will realize tighter tracking, smoother motion, and faster rapid traverse - all of which yield superior machine throughput and reliability.

Servo Drive Features

- SSt Eclipse E750 servo is 30A peak, 15 continuous @ 330Vdc
- Digital control loops with 800Hz large signal velocity bandwidth
- 2kHz small signal response
- 35 microsecond total servo phase delay. The SSt Eclipse drive is the fastest in the industry
- True, closed-loop, sinewave commutation with vector feed-forward and DQ decoupling provides near-zero torque response time at any speed. This maximizes motor responsiveness and minimizes motor heating
- The SSt Eclipse drive utilizes an adaptive control algorithm (IMT) based on Neural Fuzzy Logic
- The IMT virtually eliminates the concern of inertia matching and allows for loads of large and varying inertia without impacting performance.
- The SSt Eclipse drive uses small-signal, sliding-mode, automatic gain modulation to eliminate hunting even with extreme gains. Axes will be perfectly still and have no loss of tracking or position accuracy.



Servo Amps

- Teknic's proprietary Regressive Auto Spline™ (RAS) technology produces ultra-smooth trajectories. The profiles are jerk and jerk-derivative limited, which reduces shock, vibration, noise, and mechanical wear.
- Many safety and protection features including: Short circuit (phase-to-phase, phase-to-ground), over temperature, over voltage, over current, protected for open windings, fuse, True RMS torque limiting, automatic speed limit, motor jam detection, and much more
- Superior tracking accuracy multi-derivative, state feed-forward gains greatly improve tracking performance and do not create the audible noise and torque chatter of traditional implementations

Teknic has been designing and building digital servo drives for nearly two decades. Tens of thousands of drives are sent into the field each year to OEMs, with the first having been delivered in 1994. With that field experience and an evolutionary approach, the SSt-Eclipse Series used by MultiCam is standing on the shoulders of the drives before it, which yields not only robust performance, but also MTBF numbers that make the competition blush. The MTBF of the SSt Eclipse E750, for example, is over 700,000 hours.

6000 Series Specifications

Brushless AC Servo Motors

After extensive testing, MultiCam has found the Teknic Hudson Brushless AC Servo Motors to be the premier solution on the market today. Teknic has an extensive history in motors and controls dating back to its founding in 1985. With a long history of providing critical components to military and aerospace applications and a leading supplier to commercial and industrial applications, Teknic creates servo motors that give MultiCam machines a competitive edge in the market.

Brushless AC Servo Motor Features

- 50 lb. indefinite radial load limit 1" from face
- Brushless, maintenance-free sinewave servo motors with oversized, high precision, deep groove radial bearings being the only wear point
- Neodymium-Iron-Boron magnets providing high power density and fade-free performance
- High power-to-rotor inertia ratio
- Direct winding on electrostatically powder-coated stators gives high thermal conductivity for better RMS ratings.
- Windings are rated to 155°C, improving thermal range.
- Extremely low electrical time constants increase motor responsiveness, which provides superior tracking accuracy to competitive units.
- Low distortion, sinusoidal back EMF combined with low detent torque improves motor smoothness and lowers audible noise.
- Precision bearings both reduce viscous friction and motor noise at high speed and help smooth motion. The high precision bearings are mechanically captivated and chemically bonded to maintain proper preload and alignment under all rated load conditions and accidental impacts. The drive shaft is made of stainless steel.
- The stators are glued and mechanically locked to prevent slippage regardless of use conditions.
- Finite element analysis is utilized to reduce stress concentration on machined areas of the shaft. This allows the use of oversized bearings without sacrificing shaft strength.

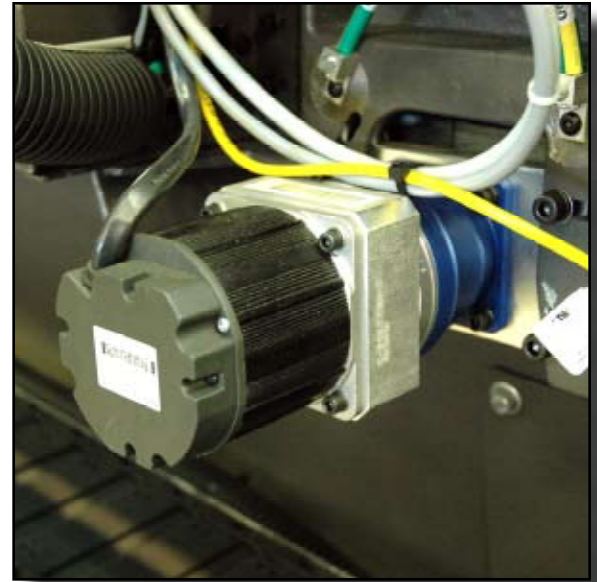

Servo Motor

- The stainless steel encoder disk is a floating differential, and the read head has a multiple-aperture grating for reliable operation even when dusty or dirty. It will not break like glass encoder disks. The read head is also fully encapsulated for increased reliability and ruggedness. Combined with the triple redundant reading/voting circuits in the drive, this provides incredibly robust encoder capability.
- The encoder housing is integral to the shaft automatically compensating for thermal expansion.
- The 4000-line encoder with quadrature sampling produces 16,000 counts per revolution.

Adaptive Automatic Torch Height Control

MultiCam has introduced one of the most advanced automatic torch height control systems on the market today. The challenge was to make the torch height control extremely responsive when cutting thin metals and very smooth when cutting thick metals. To achieve the best cut quality possible it is critical to keep the torch tip to work distance very consistent. If the torch height control is too responsive on thick metals the cut edge quality will not be smooth. If the torch height control is not responsive enough when cutting thin metals the torch will not be able to adjust quickly enough. The cut height will not be ideal and the torch may even crash into the material. Competitive torch height control systems are independent from the motion controller. They cannot automatically adapt to changes in cut speed and material thickness. The only connection to the motion controller is a signal that disables the torch height controller when the machine drops below 100% of the set cut speed. Because of this limited integration, the torch height controller is forced to use a set of parameters that is somewhere in the middle.

Unlike these controllers the MultiCam Torch Height Control is fully integrated with the motion controller. The sensitivity of the Torch Height control is automatically adjusted based on the current cutting parameters. The MultiCam gives the customer the best of both worlds. Very fast response when cutting thin metals, smooth slower adjustments when cutting thick plate. The best part is that all of these adjustments happen automatically for the end user. Height control is an integral function of the controller itself, there are fewer parts, which translates into less maintenance cost.



Quick-stop crash protection (optional)

The quick-stop crash protection torch holder makes changing consumable a snap, and protects your investment against serious damage.

During the cut process it is possible for small parts to tilt up. If the torch hits one of these obstacles, the torch release and shift to the side. The machine will pause and allow the user to fix the problem and continue on.





Auto Reference Voltage

Most systems have the user manually enter in a reference voltage for torch height. The MultiCam system automatically samples the voltage at the beginning of each program and sets this value for you. This gives you a better cut, longer consumable life, and reduces the chance for error. Why is this important? Many parameters can affect the torch height voltage. When cutting faster or slower the book value of the torch height voltage will change. It is nearly impossible for the end user to guess the correct voltage. MultiCam eliminates this guess work by automating the process.

Advanced Kerf Crossing

EZ Control automatically samples the torch height voltage at 500 times per second. The data is fed into a series of algorithms. Most of the algorithms are designed to adjust the smoothness and sensitivity of the torch height control. This is done by averaging the data over varying periods of time. When the voltage drastically changes the controller locks out torch height control.

These drastic changes in voltage are usually caused by cutting back over the kerf. Normally this occurs at the end of the cut when the lead out crosses over the lead in. Systems that do not properly adjust to kerf crossing can dip the torch at the end of the cut or even crash the torch into the material. This can cause the part to be destroyed or not properly cut out. EZ Control Advanced Kerf Crossing detects these changes in voltage and instantaneously locks out the torch height control. Once the voltage stabilizes, torch height control will resume.

- 300 IPM High Speed Z axis
- 2 process surface detection.
- Extremely responsive Ohmic sensor for high speed surface sensing. This keeps from bending material and giving a false material surface.
- Z float sensor. If the Ohmic sensor fails to read the surface, the backup sensor will read the movement in the Z axis when the torch makes contact with the material surface. Smooth and Accurate Arc Voltage Height Control. The voltage is sampled at 500 times per second; the data is averaged and then used to control the torch height level.
- 25 mm Z-axis linear bearing rails for rigid, smooth, accurate motion.

6000 Series Specifications

Standard Features



Leveling Feet



Tool Box



Operation Manual

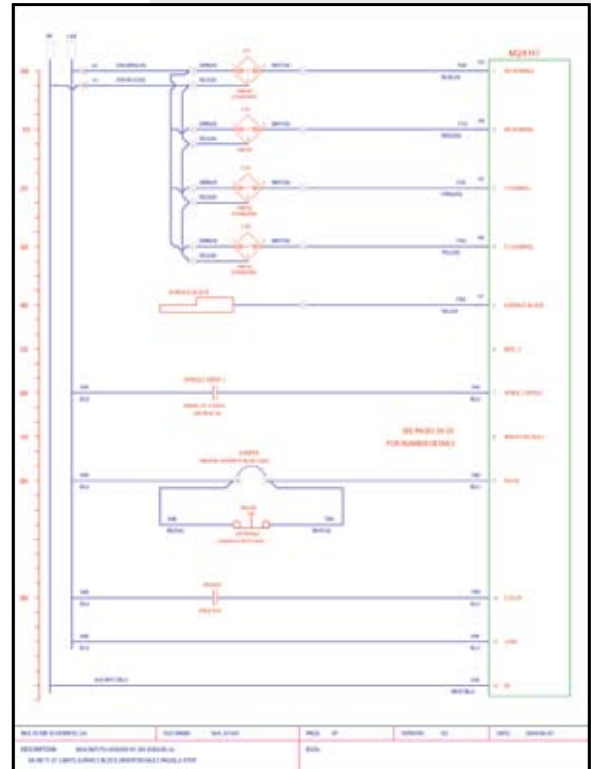

Electrical Schematics

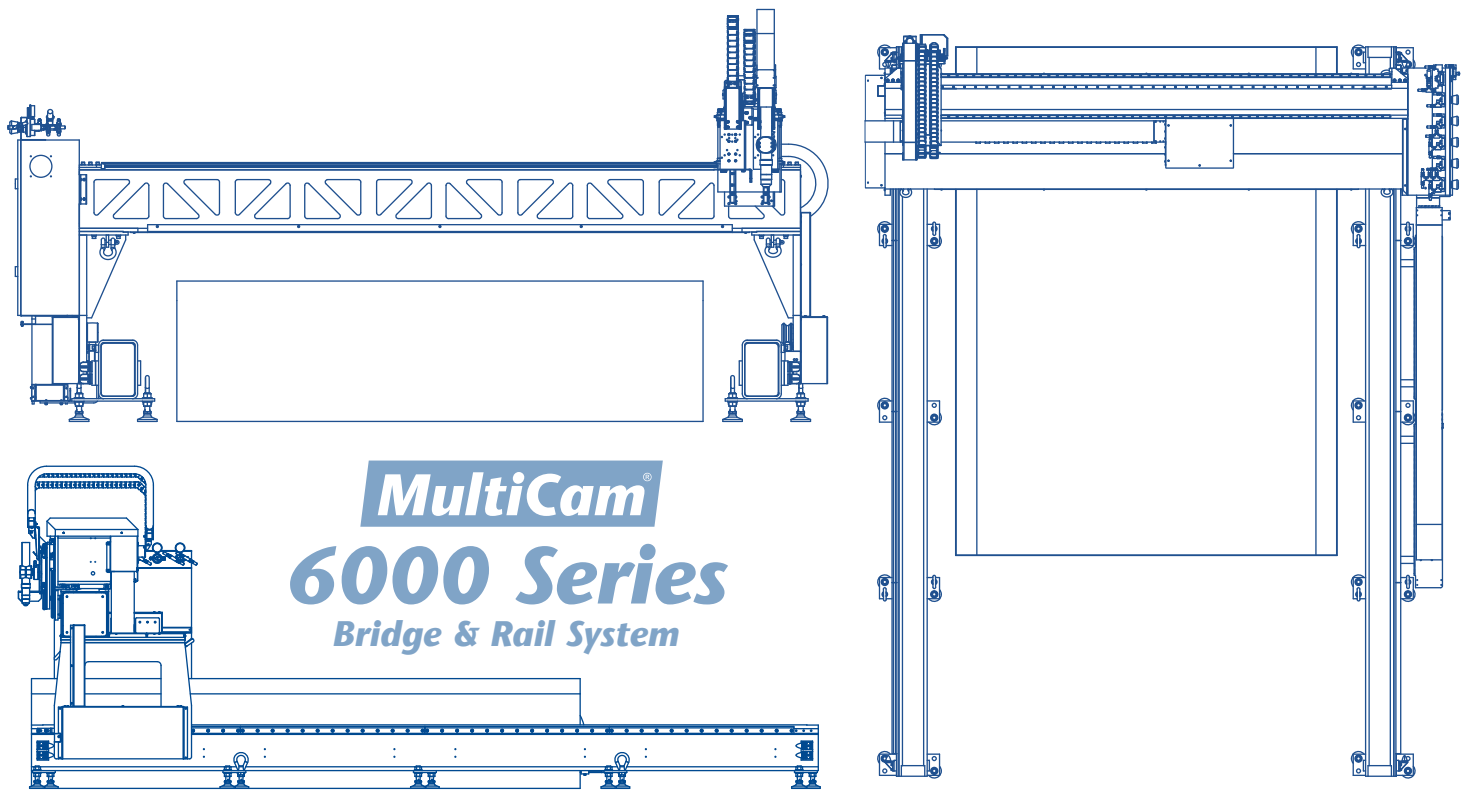

6000 Series Specs (inches)

- Z-Axis Clearance: 38.5" (without a cutting table)
- Z axis Working Range: 38" to 26"
- Z-Axis Travel: 12"
- Repeatability: +/- .001"
- Positional Displacement Accuracy: +/- .010" over 10 feet
- Cutting Speed: 800 ipm
- Rapid Traverse: 1,000 ipm
- Drive System X and Y axis: Rack and Pinion
- Drive System Z axis: Balls Screw

Size Chart (inches)

| Machine Model | Y axis Working Area | X axis Working Area |
|---------------|---------------------|---------------------|
| 6-405-P | 100" | 145" |
| 6-502-P | 120" | 60" |
| 6-505-P | 120" | 145" |
| 6-605-P | 144" | 145" |
| 6-705-P | 180" | 145" |
| 6-905-P | 240" | 145" |

*Additional Lengths can be added in 10 foot sections

6000 Series Specs (metric)

- Z-Axis Clearance: 978 mm
- Z axis Working Range: 965mm to 660 mm
- Z-Axis Travel: 305 mm
- Repeatability: +/- .025 mm
- Positional Displacement Accuracy: +/- .250 mm over 3 meters
- Cutting Speed: 20.3 m/min
- Rapid Traverse: 25.4 m/min
- Drive System X and Y axis: Rack and Pinion
- Drive System Z axis: Balls Screw

Size Chart (metric)

| Machine Model | Y axis Working Area | X axis Working Area |
|---------------|---------------------|---------------------|
| 6-405-P | 2540 mm | 3683 mm |
| 6-502-P | 3048 mm | 1524 mm |
| 6-505-P | 3048 mm | 3683 mm |
| 6-605-P | 3657 mm | 3683 mm |
| 6-705-P | 4572 mm | 3683 mm |
| 6-905-P | 6096 mm | 3683 mm |

*Additional Lengths can be added in 3048mm sections