

# NATIONAL

[www.national-1.com](http://www.national-1.com)

HEAVY DUTY BRAKES

ROLL FORMING MACHINES

MECHANICAL SHEARS

BOX AND PAN BRAKES

HAND BRAKES



## SHEAR BRAKING POWER

SMARTT, TN 37378

3 YEAR WARRANTY

MADE IN THE U.S.A

# Metal Shears - 52" 16 Gauge

## NATIONAL

**N**ational foot shears are designed for precise shearing through 16 gauge mild steel. This shear is also recommended for shearing aluminum, plastic, copper, brass and lead. Shear has heavy steel side frames, all steel cutter heads and tables with four cutting edge high carbon, high chromium blades, back gauges, table gauges, spring actuated hold down, front arm extensions, bottom treadle safety stop and full three year warranty.

**MADE IN THE USA**

**5 Year Warranty Against  
Breakage on  
Cutterheads & Tables**

All Steel cutter heads and tables.



**STANDARD HIGH CARBON  
HIGH CHROMIUM BLADES**

### Specifications

Model	N5216
Capacity: (Tensile Strength 55,000 lbs. @ rated capacity)	Mild Steel 16 Gauge: 1.6mm Stainless Steel 20 Gauge: .9 mm
Cutting length	52" 1321mm
Shipping Weight	980lbs 445 kgs
Floor Space w/Gauges	61" x 75 7/8" x 42 1/4" 1549 x 1927 x 1073mm
Floor Space w/o Gauges	61" x 34 1/4" x 42 1/4" 1549 x 870 x 1073mm



# Air Shears - 36" 12 Gauge, 52" 16 Gauge 52" 12 Gauge

## NATIONAL

All Steel cutter heads and tables.

**N**ational offers three heavy steel side frames, all steel cutter head, hold down and table. These air shears are standard with four cutting edge high carbon high chromium blades, front arm extensions, table gauges, back gauges, and heavy duty foot switch.

### Optional Accessories:

57" Squaring arm  
Model NSA 52

**MADE IN THE USA**

5 Year Warranty Against  
Breakage on  
Cutterheads & Tables



**STANDARD HIGH CARBON  
HIGH CHROMIUM BLADES**

### Specifications

Model	NA3612	NA5216	NA5212
Capacity:	Mild Steel	Mild Steel	Mild Steel
(Tensile Strength	12 Gauge: 2.7mm	16 Gauge: 1.6mm	12 Gauge: 2.7mm
55,000 lbs. @ rated capacity)	Stainless Steel	Stainless Steel	Stainless Steel
	16 Gauge: 1.6mm	20 Gauge: .9mm	16 Gauge: 1.6mm
Strokes Per Minute	Approx. 40	Approx. 40	Approx. 40
Cutting length	36"	52"	52"
	914mm	1321mm	1321mm
Shipping Weight	1100lbs	1400lbs	1600lbs
	499kgs	635kgs	726kgs
Floor Space w/Gauges	45" x 75 7/8" x 42 1/4"	61" x 75 7/8" x 42 1/4"	62" x 75 7/8" x 42 1/4"
	1143 x 1927 x 1073mm	1549 x 1927 x 1073mm	1575 x 1927 x 1073mm
Floor Space w/o Gauges	45" x 22 3/4" x 42 1/4"	61" x 22 3/4" x 42 1/4"	62" x 22 3/4" x 42 1/4"
	1143 x 578 x 1073mm	1549 x 578 x 1073mm	1575 x 578 x 1073mm
Recommended p.s.i.	100	100	100

# Hydraulic Shears - 36" 12 Gauge, 52" 16 Gauge 52" 12 Gauge, 52" 10 Gauge

## NATIONAL

**N**ational heavy duty power shears are equipped with a fully integrated hydraulic unit. Complete with electrical hydraulic valve, pilot operated-pressure relief valve, heavy duty foot switch that allows this unit to return to the top of the stroke when the operator removes his foot from the foot switch. Heavy duty double acting cylinders. Fully enclosed control panel.

The National shear is actuated by a portable shrouded electric foot switch attached to a long flexible cable so it may be positioned comfortable to the operator.

Heavy steel side frames, all steel cutter heads and tables with solid 4-edge high carbon high chromium blades. Quick adjusting back gauge for direct reading with a positive lock. Standard with table gauges and front arm extensions

### Optional Accessories:

Front operated manual digital "QUICK SET" two turn 30" back gauge.

Models: QS36, QS52

Front operated "POWER" digital back gauge

Models: NBG36, NBG52

Squaring Arm

Model: NSA52

### MADE IN THE USA

**5 Year Warranty Against Breakage on  
Cutterheads & Tables**

All Steel cutter heads and tables.



**STANDARD HIGH CARBON  
HIGH CHROMIUM BLADES**

### Specifications

Model	NH3612	NH5216	NH5212	NH5210
Capacity: (Tensile Strength 55,000 lbs. @ rated capacity)	Mild Steel 12 Gauge: 2.7mm Stainless Steel 16 Gauge: 1.6mm	Mild Steel 16 Gauge: 1.6mm Stainless Steel 20 Gauge: .9mm	Mild Steel 12 Gauge: 2.7mm Stainless Steel 16 Gauge: 1.6mm	Mild Steel 10 Gauge: 3.4mm Stainless Steel 14 Gauge: 1.9mm
Strokes Per Minute	Approx. 40	Approx. 25	Approx. 25	Approx. 25
Cutting length	36" 914mm	52" 1321mm	52" 1321mm	52" 1321mm
Shipping Weight	1200lbs 544kgs	1400lbs 635kgs	1600lbs 726kgs	1950lbs 885kgs
Floor Space w/Gauges	45" x 75 7/8" x 42 1/4" 1143 x 1927 x 1073mm	61" x 75 7/8" x 42 1/4" 1549 x 1927 x 1073mm	61" x 75 7/8" x 42 1/4" 1549 x 1927 x 1073mm	62" x 79 7/8" x 42 1/4" 1575 x 2029 x 1073mm
Floor Space w/o Gauges	45" x 22 3/4" x 42 1/4" 1143 x 578 x 1073mm	61" x 22 3/4" x 42 1/4" 1549 x 578 x 1073mm	61" x 22 3/4" x 42 1/4" 1549 x 578 x 1073mm	62" x 22 3/4" x 42 1/4" 1575 x 578 x 1073mm
Oil Reservoir Capacity	14 gal 53 liters	24 gal 91 liters	24 gal 91 liters	24 gal 91 liters
Motor	3 h.p. 208 volt 1800 rpm 240 volt 3 phase 460 volt	3 h.p. 208 volt 1800 rpm 240 volt 3 phase 460 volt	3 h.p. 208 volt 1800 rpm 240 volt 3 phase 460 volt	5 h.p. 208 volt 1800 rpm 240 volt 3 phase 460 volt



# Hydraulic Shears - 10' 1/4", 8' 1/4", 6' 1/4", 4' 1/4"

## NATIONAL

National offers four powerful heavy duty precision hydraulic shears with all steel cutter heads and tables. Standard with hydraulic rubber inserted holddowns, quick adjusting back gauge for direct reading with a positive lock, front arm extensions, table gauges, heavy duty foot switch and well lighted work area. You receive a full three year warranty. The hydraulic unit conforms to J.I.C. standards featuring simplicity of design. The National hydraulic system is simple to maintain with standard replacement parts such as valves, cylinders, hoses and oil. The National shear is actuated by a portable shrouded electric foot switch attached to a long flexible cable so it may be positioned comfortable to the operator.

National Shears have high carbon, high chromium blades with four cutting edges of premium quality tool steel and will withstand nicking and wear better than relieved blades. National blades are secured to the shear with tempered flat head screws through countersunk holes in blades. Complete cuts of full width pieces are 2" longer than specified cutting length. Underdrive construction with downward cylinders and major hydraulics under the bed gives the shear a low profile.

### Optional Accessories:

Front operated digital back gauge

Models: NBG48, NBG72, NBG96 & NBG120

Front operated manual digital "QUICK SET" two turn 32" back gauge

Models: QS48, QS72, QS96, QS120

Squaring Arm

Models: NSA48, NSA72, NSA96 & NSA120

### MADE IN THE USA

**5 Year Warranty Against Breakage on Cutterheads & Tables**

All Steel cutter heads and tables.



**STANDARD HIGH CARBON  
HIGH CHROMIUM BLADES**

### Specifications

Model	NH4825	NH7225	NH9625	NH12025
Capacity:	Mild Steel 1/4"/6.4mm	Mild Steel 1/4"/6.4mm	Mild Steel 1/4"/6.4mm	Mild Steel 1/4"/6.4mm
(Tensile Strength 55,000 lbs. @ rated capacity)	Stainless 1/8"/3.2mm	Stainless 1/8"/3.2mm	Stainless 1/8"/3.2mm	Stainless 1/8"/3.2mm
Strokes Per Minute	Approx. 20	Approx. 20	Approx. 12	Approx. 12
Cutting length	48"/1219mm	72"/1829mm	96"/2438mm	120"/3048mm
Shipping Weight	5000lbs/2268kgs	6000lbs/2722kgs	7000lbs/3176kgs	9000lbs/4091kgs
Floor Space w/Gauges	66 1/2" x 98" x 54" 1689 x 2489 x 1372mm	84" x 98" x 54" 2134 x 2489 x 1372mm	116" x 98" x 60" 2946 x 2489 x 1524mm	140" x 98" x 60" 3556 x 2489 x 1524mm
Floor Space w/o Gauges	66 1/2" x 38" x 54" 1689 x 965 x 1372mm	84" x 38" x 54" 2134 x 965 x 1372mm	116" x 39 1/4" x 60" 2946 x 997 x 1524mm	140" x 39 1/4" x 60" 3556 x 997 x 1524mm
Oil Reservoir Capacity	24gal/91 liters	24gal/91 liters	24gal/91 liters	24gal/91 liters
Motor	7 1/2 h.p. 208 volt 1800 rpm 240 volt 3 phase 460 volt	7 1/2 h.p. 208 volt 1800 rpm 240 volt 3 phase 460 volt	7 1/2 h.p. 208 volt 1800 rpm 240 volt 3 phase 460 volt	7 1/2 h.p. 208 volt 1800 rpm 240 volt 3 phase 460 volt

# Mechanical Shears - 4' 10 Gauge, 6' 10 Gauge, 8' 10 Gauge, 10' 14 Gauge

## NATIONAL

**T**hese powerful Mechanical Shears are all USA made. They offer rugged welded construction, inch-bed scales, accurate table side gauges, hold-down finger guard with non-marring urethane, positive spring actuation and high carbon, high chrome long-life tool steel blades. The upper and lower blades are interchangeable. Non-metallic gibs are maintenance free with self-lubricating bearings, continuous-cycle, single-cycle and jog for different needs. Our shears also offer a fully guarded safety foot switch, quiet operation and low power consumption.

### OPTIONAL ACCESSORIES

"QUICK SET" front operated manual digital read out back gauge 32" travel.

Models QS48, QS72, QS96, QS120

- Power front operated digital read out back gauge
- Front return sheet support
- Rear return sheet support
- Squaring arm to 4'
- Squaring arm 4' to 8'
- Squaring arm 8' to 12'
- Two front extensions
- Work light

**MADE IN THE USA**

**5 Year Warranty**



**5 Year Warranty Against  
Breakage on Cutterheads,  
Tables & Holddowns**





All Steel cutter heads and tables - Standard high carbon high chromium blades

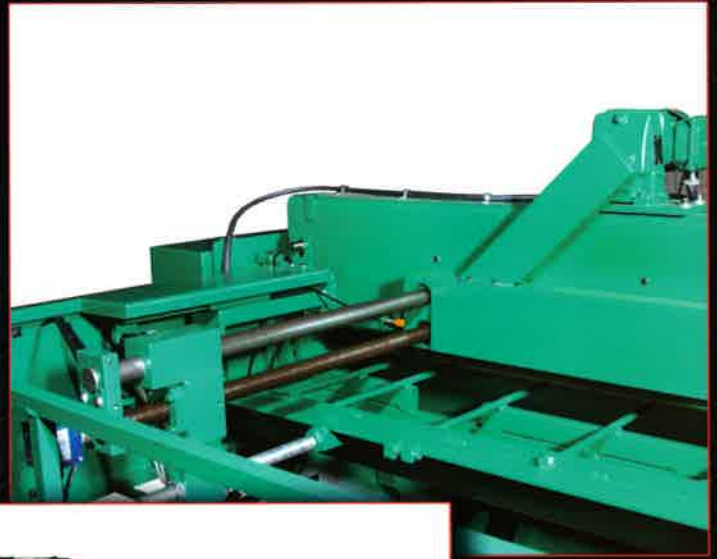

### Specifications

Model	NM410	NM610	NM810	NM1040
Capacity:	Mild Steel	Mild Steel	Mild Steel	Mild Steel
Tensile Strength	10 Gauge 3.4mm	10 Gauge 3.4mm	10 Gauge 3.4mm	14 Gauge 2mm
55,000 lbs. @ rated capacity	SS 14 Gauge 2mm	SS 14 Gauge 2mm	SS 14 Gauge 2mm	SS 16 Gauge 1.6mm
Strokes per min	40	40	40	40
Cutting Length	49"/1244	73"/1854	97"/2464"	121"/3073"
Shipping Weight	3600lbs/1632kg	4900lbs/2223kg	6850lbs/3107kg	6100lbs/2767kg
Floor Space w Gauges	73"x89"x53" 1854X2260X1346	93"x89"x53" 2362X2260X1346	117"x89"x53" 2972X2260X1346	141"x89"x53 3581X2260X1346
Floor Space w/o Gauges	73"x28"x53" 1854X711X1346	93"x28"x53" 2362X711X1346	117"x28"x53" 2972X711X1346	141"x32"x53 3581X813X1346
Motor	7 1/2 hp 208v 204v 460v 3phase	7 1/2 hp 208v 204v 460v 3phase	7 1/2 hp 208v 204v 460v 3phase	7 1/2 hp 208v 204v 460v 3phase

# Heavy Duty Box & Pan Brakes - 48" 16 Gauge

## NATIONAL

**S**implicity of design allows these brakes to work in the most direct fashion. Easy to set up and operate. Body sections are welded steel plates, with heavy truss rods and braces for longer life and greater strength. These brakes are standard with extension handles, apron stop for repeat bends, and replaceable bushings at points of wear.

**MADE IN THE USA**

**3 Year Warranty**



**MODEL S4816**



**MODEL U4816**

### Specifications

Model	U4816	S4816	Stand
Capacity: (Yield Strength 30,000 lbs. @ rated capacity)	Mild Steel 16 Gauge 1.6mm Stainless 20 Gauge .9mm	Mild Steel 16 Gauge 1.6mm Stainless 20 Gauge .9mm	
Maximum Lift of Beam	11/4"/32mm	11/4"/32mm	
Finger Width	2" 3" 4" 51mm 76mm 102mm		
Maximum Depth of Box	4"/102mm		
Bending Length	481/4"/1226mm	481/4"/1226mm	
Shipping Weight	500lbs/227kgs 1689 x 965 x 1372mm	470lbs/213kgs 2134 x 965 x 1372mm	100lbs/45kgs
Floor Space			54"x19"x271/4" 1372x483x692mm



# Box & Pan Brakes - 4' 12 Gauge, 6' 12 Gauge, 6' 16 Gauge 6' 12 Gauge, 8' 16 Gauge

## NATIONAL

**N**ational has four popular floor model box and pan brakes designed to be easy and simple to operate. Standard with 2", 3" and 4" finger widths, stop rods for repeat bends, two large counterweights, and precision bearings on the apron. All steel body construction with extra heavy tie rods for minimum deflection.

**MADE IN THE USA**

**3 Year Warranty**



### Specifications

Model	U4812	U7216	U7212	U9616
Capacity: (Yield Strength 30,000 lbs. @ rated capacity)	Mild Steel 12 Gauge: 2.7mm Stainless Steel 16 Gauge: 1.6mm	Mild Steel 16 Gauge: 1.6mm Stainless Steel 20 Gauge: .9mm	Mild Steel 12 Gauge: 2.7mm Stainless Steel 16 Gauge: 1.6mm	Mild Steel 16 Gauge: 1.6mm Stainless Steel 20 Gauge: .9mm
Finger Width	2", 3", 4" 51, 76, 102mm	2", 3", 4" 51, 76, 102mm	2", 3", 4" 51, 76, 102mm	2", 3", 4" 51, 76, 102mm
Maximum Depth of Box	4"/102mm	4"/102mm	4"/102mm	4"/102mm
Bending Length	49"/1245mm	73"/1854mm	73"/1854mm	97"/2464mm
Shipping Weight	1150lbs/522kgs	1850lbs/839kgs	2100lbs/953kgs	2200lbs/998kgs
Floor Space w/counterweight	95" x 27" x 55" 2413 x 686 x 1397mm	119" x 27" x 55" 3023 x 686 x 1397mm	129" x 27" x 59" 3277 x 686 x 1499mm	143" x 27" x 55" 3632 x 686 x 1397mm

# Heavy Duty Box & Pan Brakes - 6" Box Depth

## NATIONAL

**N**ational offers four heavy duty box and pan brakes made in the U.S.A. Standard with heavy body construction, precision bearings on the apron, two large cast iron counterweights and apron stop for repeat bends. The National name means quality.

Section fingers are precision machined from rolled steel bar stock for maximum strength. The fingers can be adjusted or removed quickly by the loosening of cap screws. Heavy duty steel plates and tension bars are precision incorporated for minimum deflection.

**MADE IN THE USA**

**3 Year Warranty**

Finger Width	3" 76mm	4" 102mm	5" 127mm	6" 152mm	Total
U6-4812	5	2	5	0	12
U6-7212	5	4	7	1	17
U6-9614	5	6	9	2	22
U6-12016	6	10	10	2	28



- A. 6 5/16"
- B. 2 1/2"
- C. 1 1/2"
- D. 1 1/4"
- E. Approx. 3"
- F. 2 5/16"
- G. Approx. 2 1/2"
- J. 9/16"

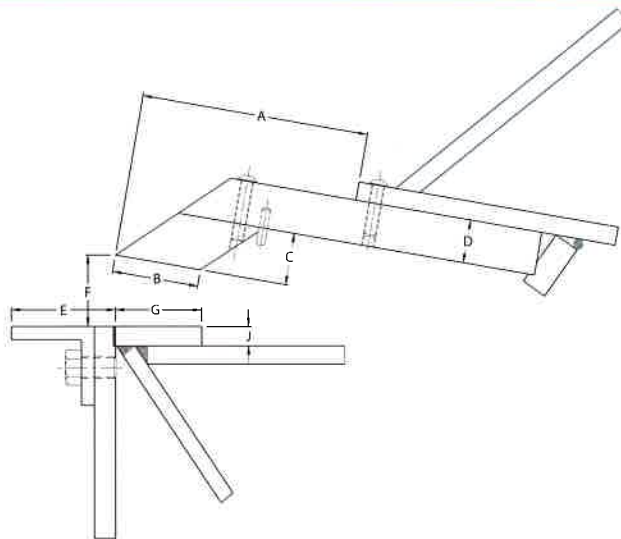

## Specifications

Model	U6-4812	U6-7212	U6-9614	U6-12016
Capacity: (Yield Strength 30,000 lbs. @ rated capacity)	Mild Steel 12 Gauge: 2.7mm Stainless Steel 16 Gauge: 1.6mm	Mild Steel 12 Gauge: 2.7mm Stainless Steel 16 Gauge: 1.6mm	Mild Steel 14 Gauge: 1.9mm Stainless Steel 18 Gauge: 1.2mm	Mild Steel 16 Gauge: 1.6mm Stainless Steel 20 Gauge: .9mm
Maximum Depth of Box	6"/152mm	6"/152mm	6"/152mm	6"/152mm
Bending Length	49"/1245mm	73"/1854mm	97"/2464mm	121"/3073mm
Shipping Weight	1900lbs/862kgs	2530lbs/1148kgs	2800lbs/1270kgs	3200lbs/1452kgs
Floor Space w/counterweight	95" x 27" x 55" 2413 x 686 x 1397mm	126 1/2" x 29" x 59" 3213 x 737 x 1499mm	153" x 27" x 59" 3886 x 686 x 1499mm	177" x 29" x 59" 4496 x 737 x 1499mm



# Hand Brakes - 4' 12 Gauge, 6' 12 Gauge, 8' 14 & 16 Gauge 10' 16 & 14 Gauge, 12' 18 Gauge

## NATIONAL

**N**ational offers these hand brakes with a great deal of pride. A simple design, utmost strength with a long life of dependable service. Streamline designed for fast, accurate bending — even for the inexperienced workman. Heavy steel body construction with extra heavy tie rods for perfect alignment. Precision bearings on the apron assures you of a smooth operating brake. These brakes come with a full three year warranty.

**MADE IN THE USA**

**3 Year Warranty**



### Specifications

<b>Model</b>	<b>N4812</b>	<b>N7212</b>	<b>N9616</b>
<b>Capacity: (Yield Strength 30,000 lbs. @ rated capacity)</b>	Mild Steel 12 Gauge: 2.7mm Stainless 16 Gauge: 1.6mm	Mild Steel 12 Gauge: 2.7mm Stainless 16 Gauge: 1.6mm	Mild Steel 16 Gauge: 1.6mm Stainless 20 Gauge: .9mm
<b>Bending Length</b>	49"/1245mm	73"/1854mm	97"/2464mm
<b>Shipping Weight</b>	1050lbs/476kgs	1800lbs/816kgs	1600lbs/726kgs
<b>Floor Space w/Counterweight</b>	95" x 27" x 55" 2413 x 686 x 1397mm	129" x 27" x 59" 3277 x 686 x 1499mm	143" x 27" x 55" 3632 x 686 x 1397mm
<b>Model</b>	<b>N9614</b>	<b>N12016</b>	<b>N12014</b>
<b>Capacity: (Yield Strength 30,000 lbs. @ rated capacity)</b>	Mild Steel 14 Gauge: 1.9mm Stainless 18 Gauge: 1.2mm	Mild Steel 16 Gauge: 1.6mm Stainless 20 Gauge: .9mm	Mild Steel 14 Gauge: 1.9mm Stainless 18 Gauge: 1.2mm
<b>Bending Length</b>	97"/2464mm	121"/3073mm	121"/3073mm
<b>Shipping Weight</b>	1750lbs/794kgs	2800lbs/1270kgs	3200lbs/1452kgs
<b>Floor Space w/Counterweight</b>	153" x 27" x 59" 3886 x 686 x 1499mm	177" x 29" x 59" 4496 x 737 x 1499mm	177" x 29" x 59" 4496 x 737 x 1499mm
<b>Model</b>	<b>N14418</b>		
<b>Capacity: (Yield Strength 30,000 lbs. @ rated capacity)</b>	Mild Steel 18 Gauge: 1.3mm Stainless 22 Gauge: .85mm		
<b>Bending Length</b>	145"/3683mm		
<b>Shipping Weight</b>	3450lbs/1553kgs		
<b>Floor Space w/Counterweight</b>	201" x 29 x 59" 5105 x 737 x 1499mm		

# Power Roll Forming Machine - 48" & 72" x 16 Gauge

## NATIONAL

**N**ational's 3" and 4" power rolls are designed for simple operation. Standard with forward and reverse drum switch. Quick release upper roll. Positive chain drive. Heavy duty gear box. Front guard for additional safety. Heavy duty stand is standard.

National's rolls incorporate three precision turned, ground, and polished high carbon steel rolls. Extra heavy duty end frames with quick release handle on the right front for speedy production forming.

The drive train is powered with a heavy duty precision reduction gear box to assure durability and long life. The electric panel and gear box are housed in a ventilated stand for protection.

Precision roll adjustment is achieved by turning the hand wheel on the left end of the roll. Repeatability is maintained by the forming scale above the hand wheel.

**MADE IN THE USA**

**3 Year Warranty**



### Specifications

Model	NR4816	NR7216
Capacity: (Yield Strength 30,000 lbs. @ rated capacity)	16 Gauge: 1.6mm	Capacity: (Yield Strength 16 Gauge: 1.6mm
Maximum Forming Length	48 1/4"/1226mm	72 1/4"/1835mm
Diameter of Roll	3"/76mm	4"/102mm
Minimum Forming Radius	1 1/2"/38mm	2"/51mm
Wire Grooves (Optional)	3/8", 1/2", 5/8"/10mm, 13mm, 16mm	3/8", 1/2", 5/8"/10mm, 13mm, 16mm
Roll Speed	18 rpm/14.13 sfpm	18 rpm/14.13 sfpm
Motor: 110-220 Single PH 208-220-440 3 PH	1 hp	1 hp
Floor Space (l x w x h)	64" x 37" x 44 1/2" 1626 x 940 x 1130mm	88" x 26" x 43 3/4" 2335 x 660 x 1111mm
Shipping Weight	970lbs/440kgs	1740lbs/814kgs



# Quick Set® - Two Turn Manual Digital Readout Back Gauge

## NATIONAL

Linear digital measuring system showing metric, decimal or fractional display with accuracy and repeatability.

### TRAVEL IN 2 SECONDS

30" Travel on 52" Shears  
32" Travel on 1/4 Shears  
32" Travel on Mechanical Shears

MADE IN THE USA

1 Year Warranty



# Front Operated Power Operated Back Gauge

## NATIONAL

### L.E.D. CONTROL

- Precision digital front operated back gauge
- Control panel located out of the work area, yet convenient for the operator.
- Precision Thomson bearings
- Max travel 30"/762mm
- Precision reliable repeatability improves cutting accuracy.
- Shipped assembled for easy mounting
- Digital readout in increments of one thousandth of an inch
- No memory loss due to power failure
- Easy mounting, can be retrofitted to any National shear



MADE IN THE USA

3 Year Warranty

### Specifications

Model	NBG36	NBG52	NBG48	NBG72	NBG96	NBG120
Floor Space (l x w x h)	36" x 44" x 161/2" 915 x 1118 x 419mm	511/4" x 44" x 161/2" 1302 x 1118 x 419mm	511/4" x 48" x 19" 1302 x 1219 x 483mm	72" x 48" x 19" 1829 x 1219 x 483mm	81" x 48" x 19" 2057 x 1219 x 483mm	88" x 48" x 19" 2235 x 1219 x 483mm
Shipping Weight	300lbs/136kgs	340lbs/154kgs	380lbs/172kgs	480lbs/218kgs	580lbs/261kgs	680lbs/306kgs
Travel	30"/762mm	30"/762mm	30"/762mm	30"/762mm	30"/762mm	30"/762mm

## Conversion & Equivalents Tables

THICKNESS CONVERSIONS  $\frac{50}{\text{TENSIL}} \times \text{GAUGE} = \text{MAX. CUTTING THICKNESS}$

		Soft Metal Table (I.E. ALUMINUM, ECT.)															
		STD.															
Tensil		50	47	45	43	40	37	35	33	30	27	25	23	20	18	16	14
16 ga.	.067	.067	.071	.074	.077	.083	.090	.095	.101	.111	.123	.134	.145	.167	.185	.209	.239
12 ga.	.113	.113	.119	.125	.131	.141	.152	.160	.170	.187	.209	.226	.245	.282	.313	.352	.403
10 ga.	.142	.142	.150	.157	.164	.177	.191	.201	.214	.235	.262	.284	.308	.355	.393	.443	.506
1/4"	.250	.250	.265	.277	.290	.312	.337	.355	.377	.415	.462	.500	.542	.625	.692	.780	.892



# Squaring Arm

## NATIONAL

**N**ational brings to you a squaring arm constructed of high tensile strength, durable solid steel. National's squaring arm comes with 57" to 60" black oxidized scale with 1/16" increments. This squaring arm comes with jack screws for easy leveling. National's squaring arms are easily assembled on the left side of the machine.

**MADE IN THE USA**

**1 Year Warranty**



### Specifications

Model	NSA52	NSA48	NSA72	NSA96	NSA120
Length	431/2"/1105mm	45"/1143mm	45"/1143mm	45"/1143mm	45"/1143mm
Shipping Weight	72lbs/33kgs	107lbs/49kgs	107lbs/49kgs	107lbs/49kgs	107lbs/49kgs

Hard Metal Table (I.E. Stainless, ECT.)

Tensil	50	52	55	57	60	62	64	65	67	70	75	77	80	85	90
16 ga. .067	.067	.064	.060	.058	.055	.054	.052	.051	.049	.047	.044	.043	.041	.039	.037
12 ga. .113	.113	.108	.102	.099	.094	.091	.088	.086	.084	.080	.075	.073	.070	.066	.062
10 ga. .142	.142	.136	.129	.124	.118	.114	.110	.109	.105	.101	.094	.092	.088	.083	.078
1/4" .250	.250	.240	.227	.219	.208	.201	.195	.192	.186	.178	.166	.162	.156	.147	.138

AISI SHEET GAUGE EQUIVALENTS IN DECIMAL INCHES

GAUGE	THICK	TOL. HR. P&O	TOL. CR.	GAUGE	THICK	TOL. HR. P&O	TOL. CR.	GAUGE	THICK	TOL. HR. P&O	TOL. CR.
4	.224	.217 .232		11	.120	.128 .112	.126 .114	18	.048	.054 .042	.052 .042
5	.209	.202 .218		12	.105	.113 .097	.111 .099	19	.042		.046 .038
6	.194	.186 .203		13	.090	.097 .083	.095 .085	20	.036		.039 .033
7	.179	.187 .171	.187 .171	14	.075	.082 .068	.080 .070	21	.033		.036 .030
8	.164	.172 .156	.172 .156	15	.067	.074 .060	.072 .062	22	.030		.033 .027
9	.149	.157 .141	.157 .141	16	.060	.067 .053	.065 .055	23	.027		.030 .024
10	.134	.142 .126	.140 .128	17	.054	.060 .048	.058 .050	24	.024		.027 .021

# NATIONAL

## WARRANTY

Each machine will be warranted for a period of three years from date of shipment. The warranty will cover the cost of any parts found to be defective upon our examination. We will not be liable for any shipping charges, installation costs or any other expenses.

This Warranty will not apply to modified machines, misuse or unauthorized repair work.

National Sheet Metal Machines, Inc. reserves the right to change design and parts for the enhancement of machines at our discretion.

### 3 Year Warranty

## Sheet Metal Machines, Inc.

FOR PARTS & SERVICE, PLEASE CONTACT:

# AHB

Tooling & Machinery, Inc.  
Complete Metalworking Solutions

ISO CERTIFIED

(800) 991-4225

WWW.AHBINC.COM

CUSTOMERSERVICE@AHBINC.COM

ROSEVILLE SAGINAW JACKSON