

APPROX TOTAL WEIGHT 3000 LBS

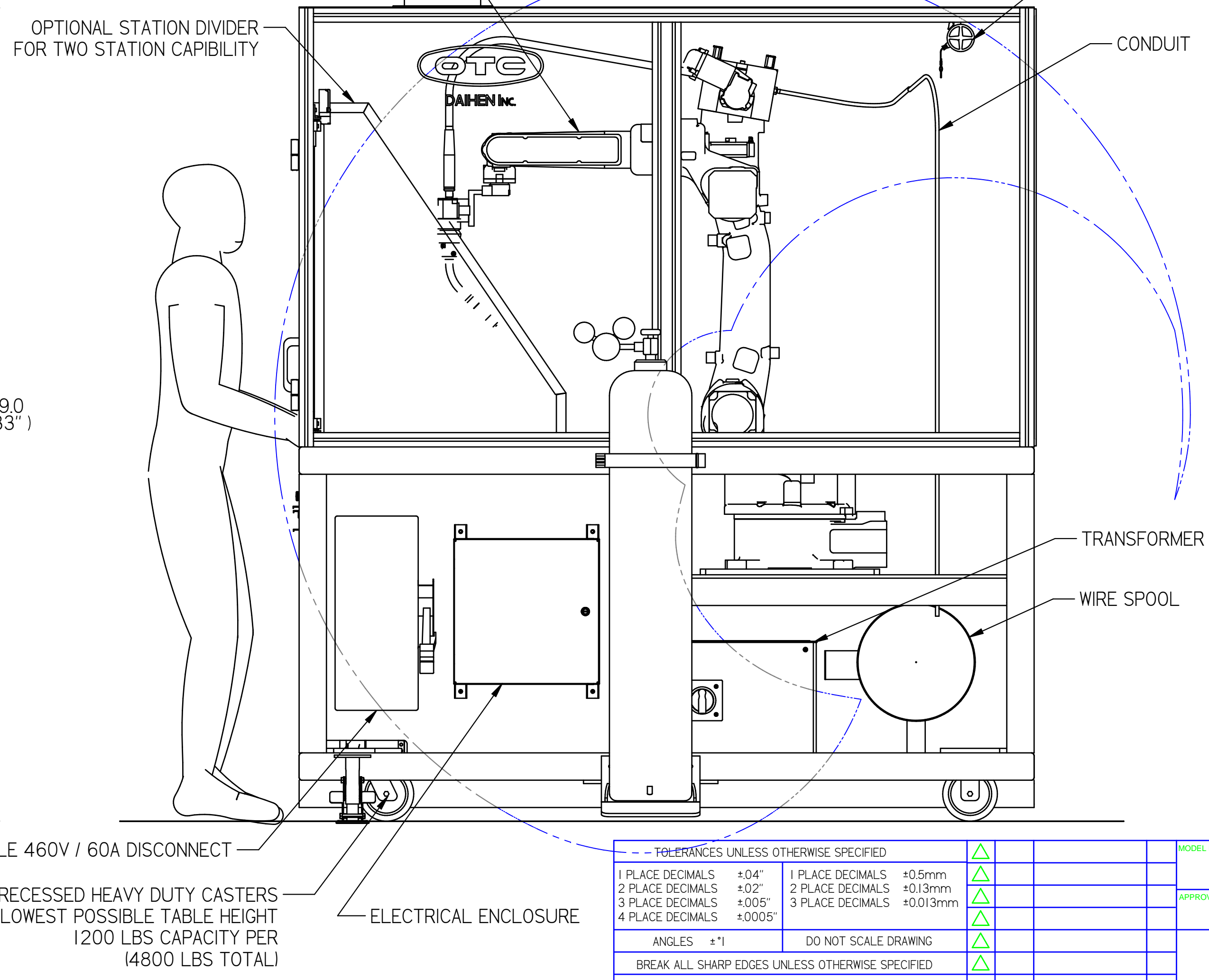

TOLERANCES UNLESS OTHERWISE SPECIFIED				THIRD ANGLE	MATERIAL
1 PLACE DECIMALS	±0.4"	1 PLACE DECIMALS	±0.5mm		-
2 PLACE DECIMALS	±0.2"	2 PLACE DECIMALS	±0.3mm		PROD. QTY.
3 PLACE DECIMALS	±0.05"	3 PLACE DECIMALS	±0.13mm		-
4 PLACE DECIMALS	±0.005"	4 PLACE DECIMALS	±0.013mm		ARTICLE
ANGLES ±1°				SCALE	1:10
DO NOT SCALE DRAWING				DATE	8/9/22
BREAK ALL SHARP EDGES UNLESS OTHERWISE SPECIFIED				APPROVAL	AGB
STAMP PART NO. AND REVISION LETTER ON EACH PART				DATE	
				REV.	
				DESCRIPTION	
				DRWN	
				MODEL No.	eCO-Mini
				CHDK	
				DRAWN	AGB
				DATE	8/9/22
				ARTICLE	GENERAL ASSY
				DRWG No.	IMI064A00

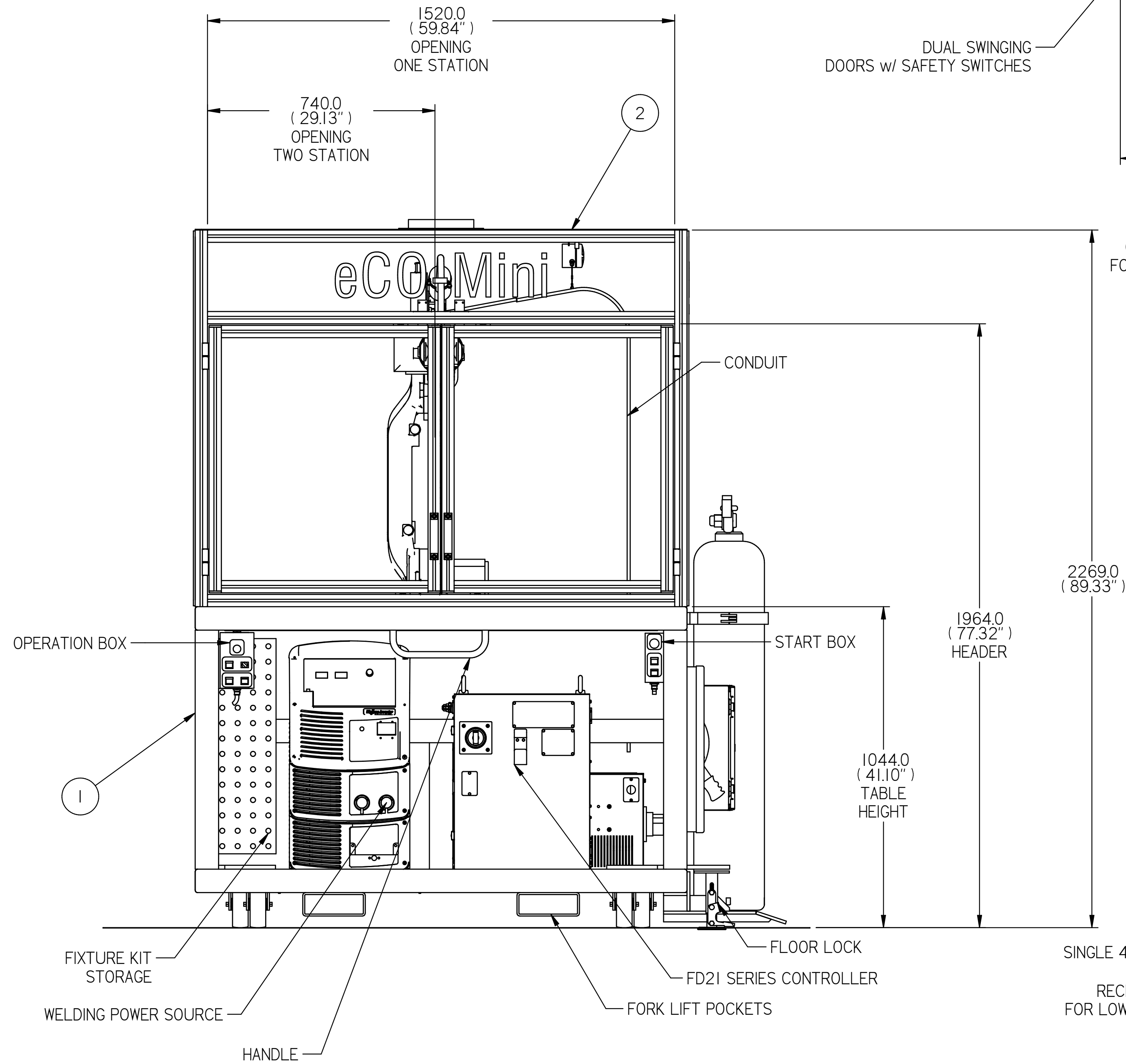

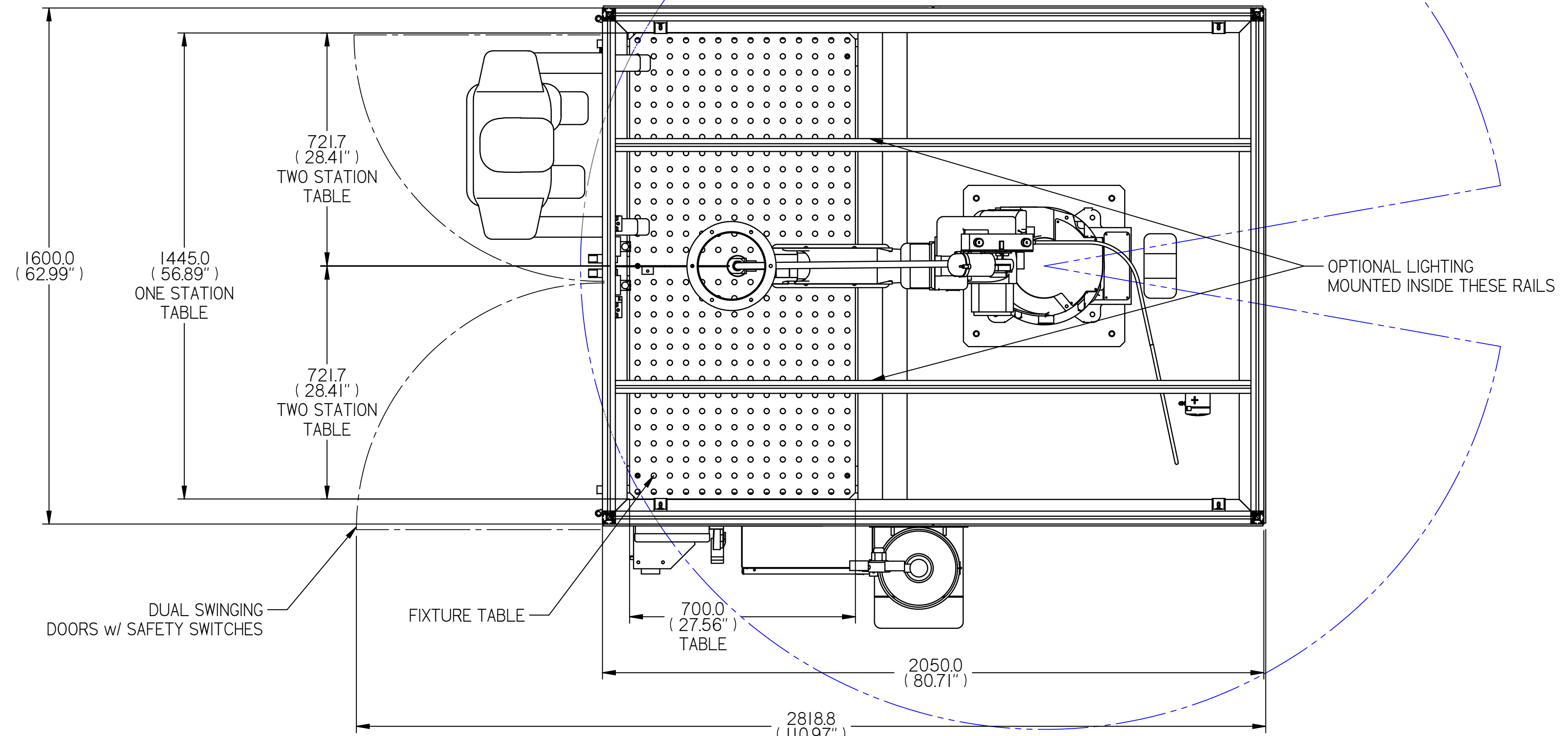
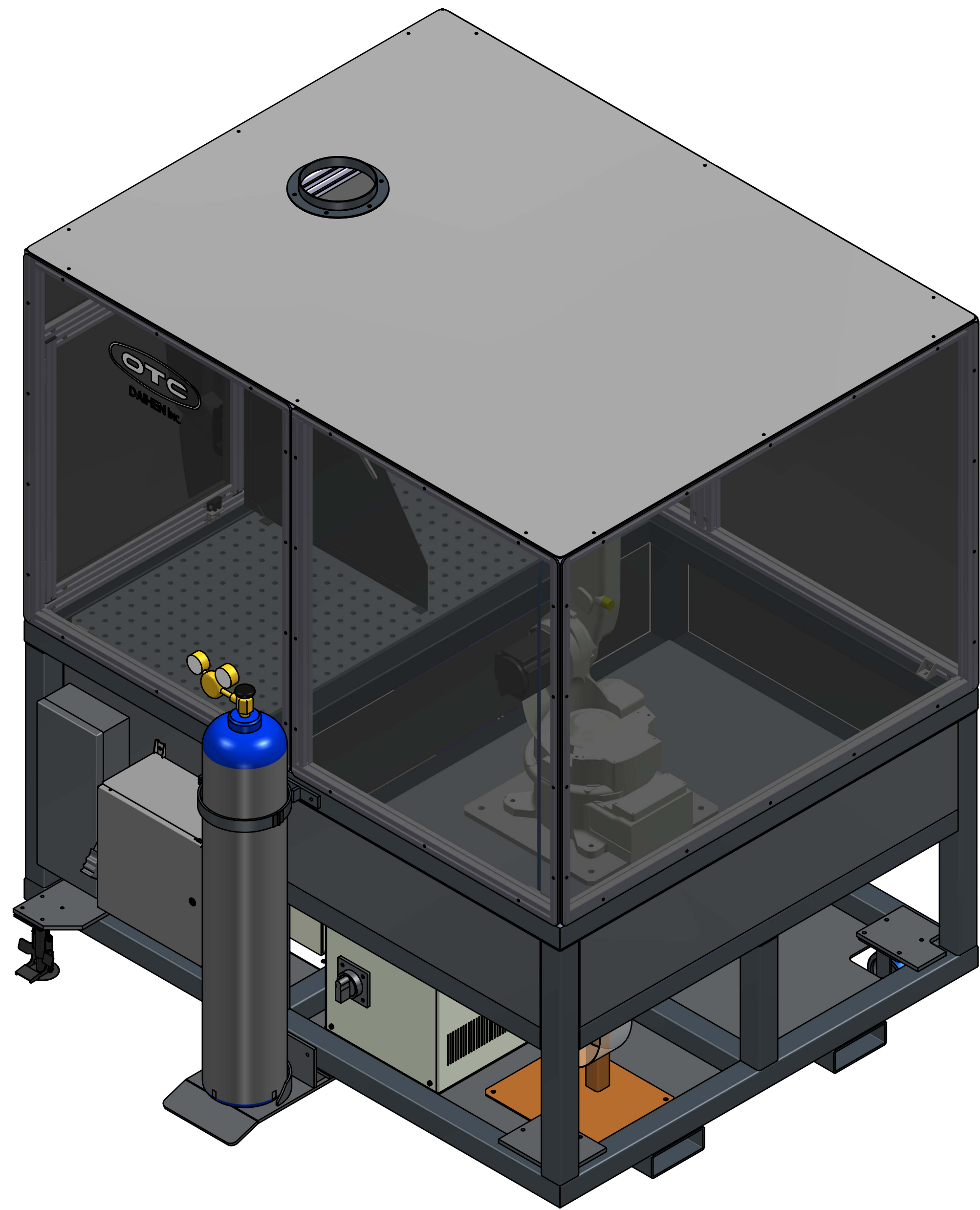

OPTIONAL EXHAUST HOOD  
w/ DUCT ADAPTER

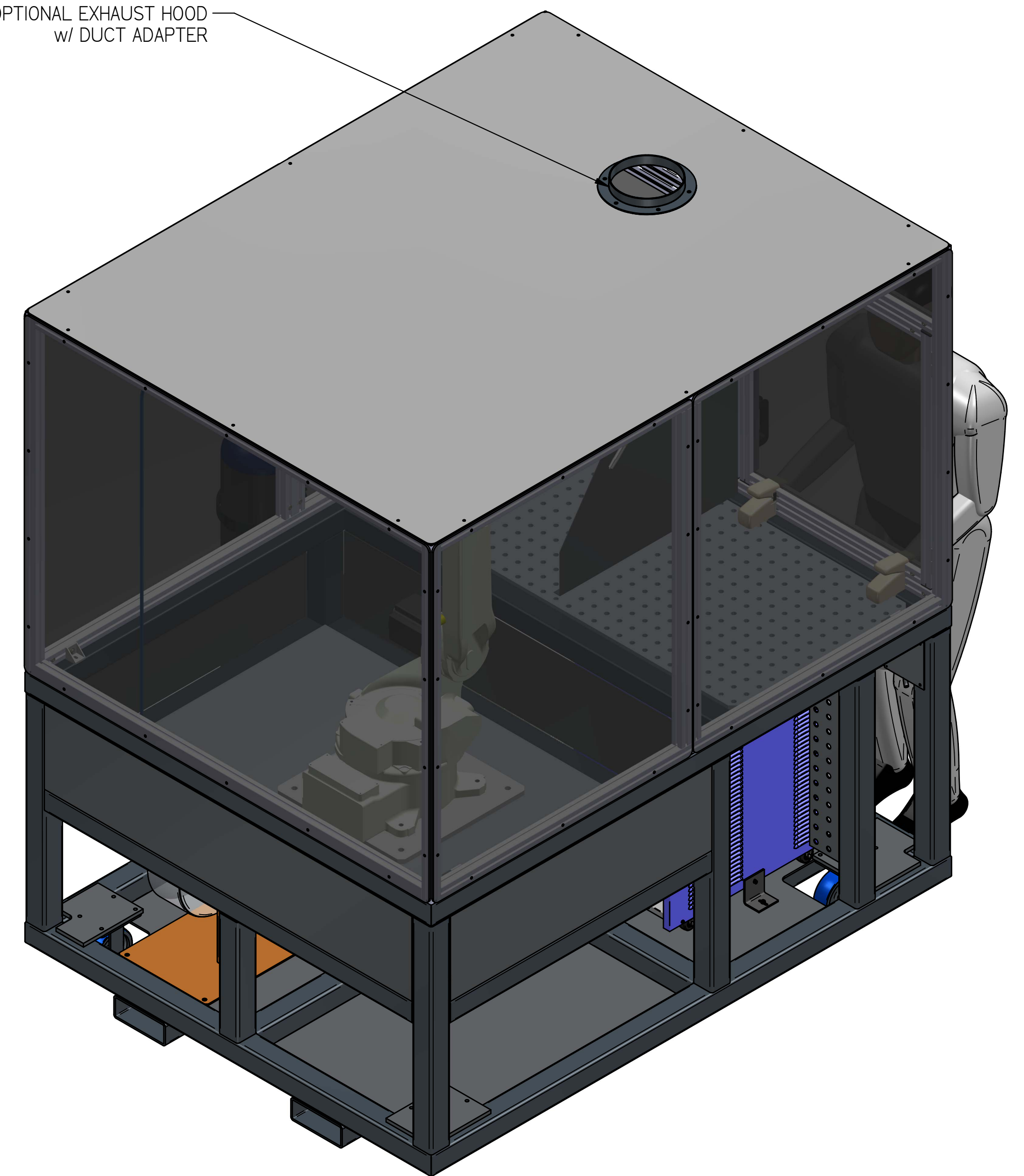

TOLERANCES UNLESS OTHERWISE SPECIFIED				△				MODEL No.	eCO-Mini	THIRD ANGLE SCALE	MATERIAL	-	
1 PLACE DECIMALS	±.04"	1 PLACE DECIMALS	±0.5mm	△				APPROVAL	CHKD	SCALE	1:10	PROD. QTY.	-
2 PLACE DECIMALS	±.02"	2 PLACE DECIMALS	±0.13mm	△				DRAWN	AGB	DATE	8/9/22	ARTICLE	-
3 PLACE DECIMALS	±.005"	3 PLACE DECIMALS	±0.013mm	△								GENERAL ASSY	
4 PLACE DECIMALS	±.0005"			△								DWG No.	IMI064A00
ANGLES		±1°		△				<b>DAHEN, Inc.</b>					
DO NOT SCALE DRAWING				△									
BREAK ALL SHARP EDGES UNLESS OTHERWISE SPECIFIED				△									
STAMP PART NO. AND REVISION LETTER ON EACH PART				△	REV.	DATE	DESCRIPTION	DRAWN					



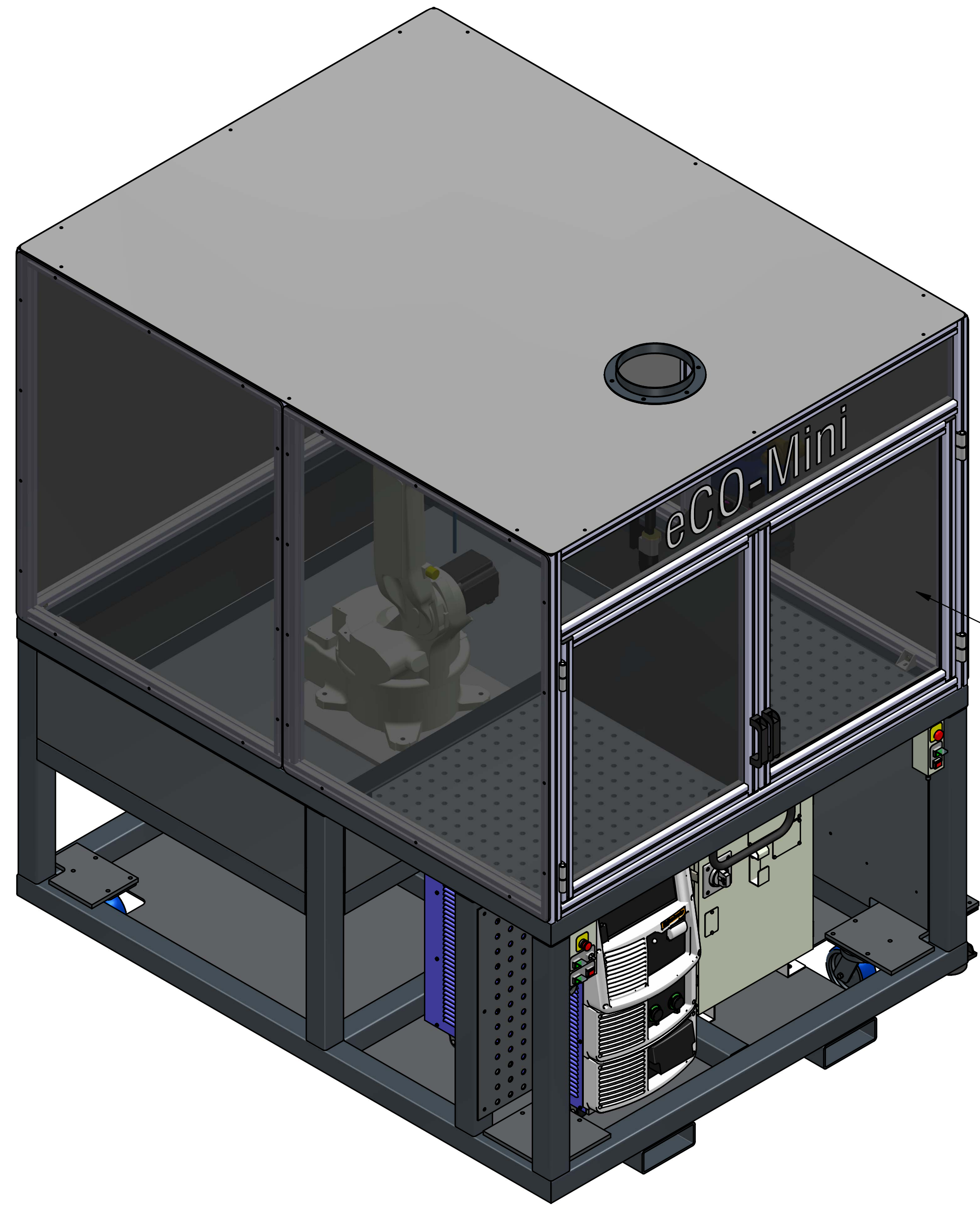

EXTRUDED ALUMINUM  
UPPER FRAME

DARK SMOKE ACRYLIC  
PANELS ALL AROUND

DAIHEN GRAY PAINT

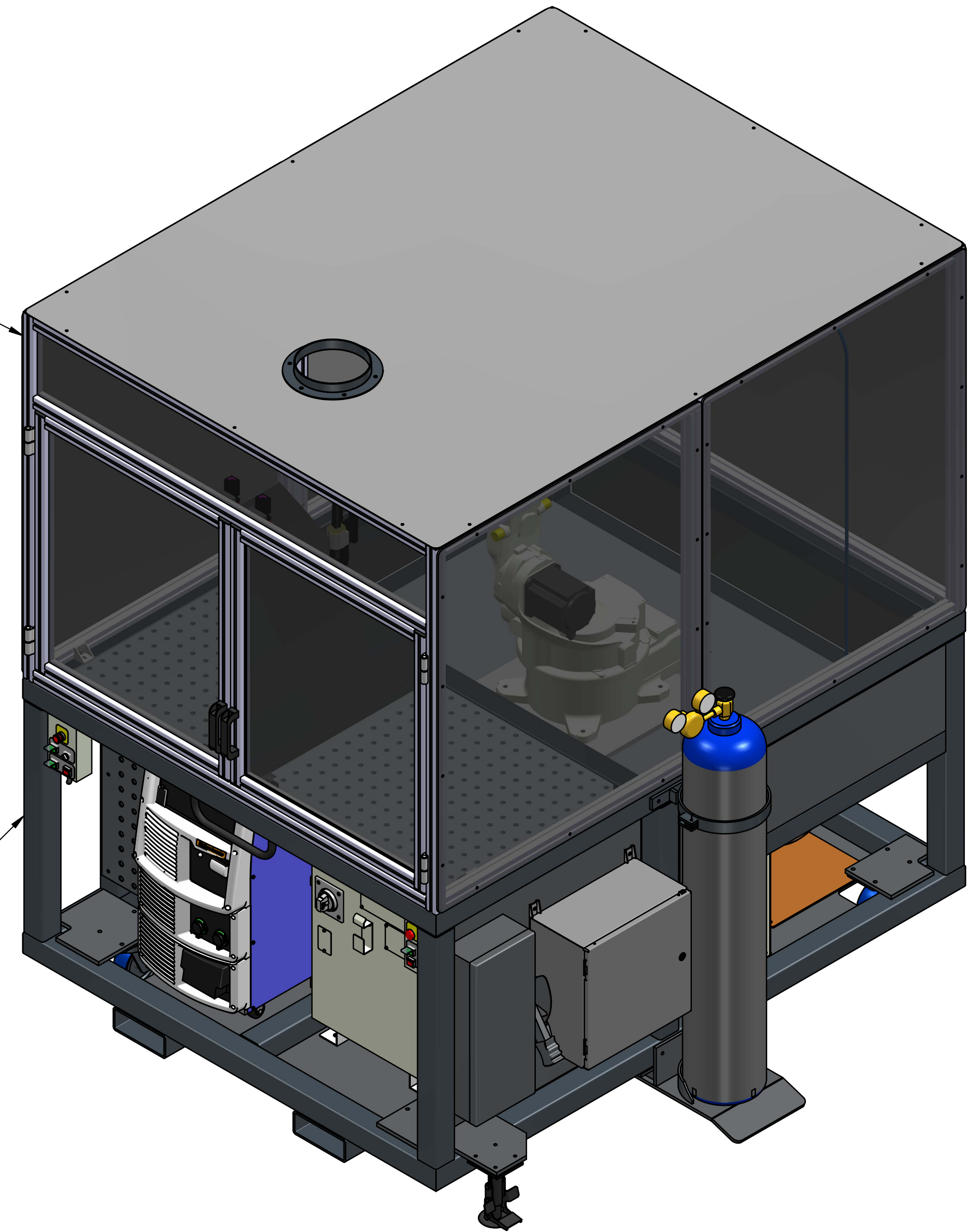

TOLERANCES UNLESS OTHERWISE SPECIFIED				THIRD ANG	MATERIAL
1 PLACE DECIMALS	±.04"	1 PLACE DECIMALS	±0.5mm	SCALE	-
2 PLACE DECIMALS	±.02"	2 PLACE DECIMALS	±0.13mm	DATE	8/9/22
3 PLACE DECIMALS	±.005"	3 PLACE DECIMALS	±0.013mm	APPROVAL	AGB
4 PLACE DECIMALS	±.0005"	DO NOT SCALE DRAWING		DRAWN	AGB
ANGLES	±1°	BREAK ALL SHARP EDGES UNLESS OTHERWISE SPECIFIED		DATE	8/9/22
STAMP PART NO. AND REVISION LETTER ON EACH PART				REV.	
				DATE	
				DESCRIPTION	
				DRAWN	
				MODEL No.	eCO-Mini
				THIRD ANG	1:10
				SCALE	1:10
				DATE	8/9/22
				APPROVAL	AGB
				DRAWN	AGB
				DATE	8/9/22
				ARTICLE	GENERAL ASSY
				DWG No.	IMI064A00