

ROSCAMAT[®] USA

The World's Best Tapping Arm

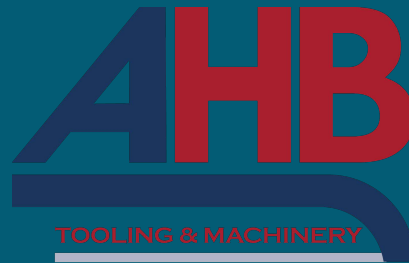

COMPLETE
METALWORKING
SOLUTIONS

(800) 991-4225

www.ahbinc.com

ISO Certified

customerservice@ahbinc.com

Tap Easy.



TAPPING ARMS INDEX

ELECTRIC

PNEUMATIC

4 Mosquito

Tap up to 9/16"

➡ Reach: 30"

↑ Height: 20"

5 Tiger

Tap up to 7/8"

➡ Reach: 40"

↑ Height: 21"

6 Dragon

Tap up to 7/8"

➡ Reach: 88"

↑ Height: 44"

7 Shark

Tap up to 1-3/8"

➡ Reach: 48"

↑ Height: 32"

8 200

Tap up to 9/16"

➡ Reach: 37"

↑ Height: 26"

9 400

Tap up to 7/8"

➡ Reach: 43"

↑ Height: 27"

10 500

Tap up to 7/8"

➡ Reach: 88"

↑ Height: 44"

11 Tap Easy

12 Tables

13 Accessories

14 Helicoil® Insertion Tools

15 Tap Adapters



SAFETY WARNING

Roscamat@USA products are engineered and manufactured with safety in mind. The heat treat specifications exceed or meet all standards. All of the products manufactured by Roscamat@USA are designed to perform without any undue safety issues when caution, common sense and proper safety practices are followed. The use of cutting tools and toolholders is safe when proper application and protection guidelines are observed. Even when these proper precautions are taken, it is possible that fragments of a cutting tool, cutting material, or holding device may be thrown at a very high rate of speed and have potential to cause severe bodily harm. It is imperative that general safety precautions and safety glasses be used at all times.

Tap Easy.

Quality & Dependability

- Heavy duty cast aluminum construction
- Adjustable balance for easy maneuverability
- More than 32 years of experience designing, manufacturing and servicing tapping arms

Light & Versatile

- Light weight and compact size allow for easy set up and relocation
- Reaming, countersinking, fastening, Helicoil® insertion & small diameter drilling

Practical & Simple

- Uses standard Bilz®-Style quick change tap adapters
- Utilize interchangeable speed modules to get the right torque and RPM for the job
- Wide range of models and options allow you to precisely choose the perfect arm for your application

Reliable & Safe

- One year warranty against defects in materials and workmanship
- Robust materials & construction exceed design standards providing a lifetime of use

Precisely Engineered Motors

- Roscamat®USA motors are designed, engineered and built for tapping
- High frequency, low noise electric motor uses 10x less energy than pneumatic



Also available in 220V



WARRANTY

Roscamat®USA tapping arms carry a full one year warranty of the machine against manufacturer defects. The warranty does not cover any damage caused by overloads, improper use and handling, and using the machine for anything other than its intended use as a tapping machine. Our warranty covers labor and parts during the one year period.

Reach

→ 30"

↑ 20"

Capacity

US: #0 - 9/16"

METRIC: M2 - M14

MOSQUITO

ROSCAMAT®



Also available in 220V

Options

- Single or Variable Speed
- Vertical (V) or Vertical/Horizontal (VH)
- Automatic Lubrication

Mosquito Vertical

EDP		Description	Orientation	Auto Tool Lubrication	Speed RPM	Capacity		Max Torque (ft-lb _r)
110V	220V					Inch	Metric	
R020100F	R020200F	Mosquito Vertical 300 RPM	Vertical		300	#0 - 1/16"	M2 - M14	27
R020300F	R020400F	Mosquito Vertical 300 RPM with Lubrication	Vertical	●	300	#0 - 1/16"	M2 - M14	27
R010100F	R010200F	Mosquito Vertical 600 RPM	Vertical		600	#0 - 3/8"	M2 - M10	13
R010300F	R010400F	Mosquito Vertical 600 RPM with Lubrication	Vertical	●	600	#0 - 3/8"	M2 - M10	13
R050100F	R050200F	Mosquito Vertical/Horizontal 300 RPM	Vertical/Horizontal		300	#0 - 1/16"	M2 - M14	27
R050300F	R050400F	Mosquito Vertical/Horizontal 300 RPM with Lubrication	Vertical/Horizontal	●	300	#0 - 1/16"	M2 - M14	27
R040100F	R040200F	Mosquito Vertical/Horizontal 600 RPM	Vertical/Horizontal		600	#0 - 3/8"	M2 - M10	13
R040300F	R040400F	Mosquito Vertical/Horizontal 600 RPM with Lubrication	Vertical/Horizontal	●	600	#0 - 3/8"	M2 - M10	13
R030100F	R030200F	Mosquito Vertical 300-600 RPM	Vertical		300-600	#0 - 1/16"	M2 - M14	27
R030300F	R030400F	Mosquito Vertical 300-600 RPM with Lubrication	Vertical	●	300-600	#0 - 1/16"	M2 - M14	27
R060100F	R060200F	Mosquito Vertical/Horizontal 300-600 RPM	Vertical/Horizontal		300-600	#0 - 1/16"	M2 - M14	27
R060300F	R060400F	Mosquito Vertical/Horizontal 300-600 RPM with Lubrication	Vertical/Horizontal	●	300-600	#0 - 1/16"	M2 - M14	27

Reach
 → 40"
 ↑ 21"

Capacity
 US: #0 - 7/8"
 METRIC: M1.6 - M27



Tiger Vertical



Also available in 220V

Options

- Tapping Depth Control
- Vertical (V) or Vertical/Horizontal (VH)
- Automatic Lubrication

EDP		Description	Orientation	Auto Tool Lubrication	Depth Control	Speed RPM
110V	220V					
R04211F	R04201F	Tiger Vertical	Vertical			90 - 2100
R04212F	R04202F	Tiger Vertical with Lubrication	Vertical	●		90 - 2100
R04215F	R04203F	Tiger Vertical with Depth Control	Vertical		●	90 - 2100
R04214F	R04204F	Tiger Vertical with Lubrication & Depth Control	Vertical	●	●	90 - 2100
R04311F	R04205F	Tiger Vertical/Horizontal	Vertical/Horizontal			90 - 2100
R04313F	R04206F	Tiger Vertical/Horizontal with Lubrication	Vertical/Horizontal	●		90 - 2100
R04216F	R04207F	Tiger Vertical/Horizontal with Depth Control	Vertical/Horizontal		●	90 - 2100
R04217F	R04208F	Tiger Vertical/Horizontal with Lubrication & Depth Control	Vertical/Horizontal	●	●	90 - 2100

Interchangeable Speed Modules*

EDP	Description	Capacity		Adapter Size	Max Torque (ft-lb _f)
		Inch	Metric		
R40510F	90RPM Module	5/16" - 7/8"	M8 - M22	#2	66
R40520F	170RPM Module	5/16" - 5/8"	M8 - M22	#2	58
R40530F	300RPM Module	#0 - 9/16"	M1.6 - M14	#1	32
R40540F	550RPM Module	#0 - 1/2"	M1.6 - M12	#1	18
R40550F	750RPM Module	#0 - 3/8"	M1.6 - M10	#1	13
R40560F	1050RPM Module	#0 - 5/16"	M1.6 - M18	#1	9
R40570F	2100RPM Module	Drill up to 5/16" ø		B16	4



*Module required for tapping. Arm & module sold separately.

Reach

➔ 88"

⬆ 44"

Capacity

US: #0 7/8"

METRIC: M1.6 - M27

DRAGON

RASCAMAT®

110V
ELECTRIC

TAPPING
ARMS

Also available in 220V

Features

- Maximum Reach

Options

- Tap at Any Angle
- Automatic Lubrication



Dragon Any Angle

EDP		Description	Orientation	Auto Tool Lubrication	Speed RPM
110V	220V				
R08101F	R08201F	Dragon Vertical	Vertical		90-2100
R08102F	R08202F	Dragon Vertical with Lubrication	Vertical	●	90-2100
R08103F	R08203F	Dragon RHM Any Angle Manual	Any Angle		90-2100
R08104F	R08204F	Dragon RHM-E Any Angle Manual with Lubrication	Any Angle	●	90-2100
R08105F	R08205F	Dragon RHC Any Angle Constant	Any Angle		90-2100
R08106F	R08206F	Dragon RHC-E Any Angle Constant with Lubrication	Any Angle	●	90-2100

Interchangeable Speed Modules*

EDP	Description	Capacity		Adapter Size	Max Torque (ft-lb _i)
		Inch	Metric		
R40510F	90RPM Module	5/16" - 7/8"	M8 - M22	#2	66
R40520F	170RPM Module	5/16" - 5/8"	M8 - M22	#2	58
R40530F	300RPM Module	#0 - 9/16"	M1.6 - M14	#1	32
R40540F	550RPM Module	#0 - 1/2"	M1.6 - M12	#1	18
R40550F	750RPM Module	#0 - 3/8"	M1.6 - M10	#1	13
R40560F	1050RPM Module	#0 - 5/16"	M1.6 - M18	#1	9
R40570F	2100RPM Module	Drill up to 5/16" ∅		B16	4



*Module required for tapping. Arm & module sold separately.

Reach
 → 48"
 ↑ 32"

Capacity
 US: #0 - 1-3/8"
 METRIC: M2 - M36

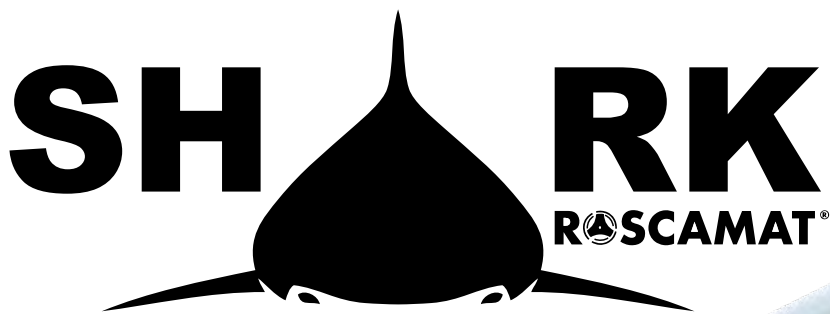

110V
 ELECTRIC
TAPPING
ARMS

Also available in 220V

Features

- Tapping Depth Control
- Automatic Lubrication

Options

- Vertical (V) or Vertical/Horizontal (VH)

Shark Vertical/Horizontal with Lubrication & Depth Control

EDP		Description	Orientation	Auto Tool Lubrication	Depth Control	Speed RPM
110V	220V					
R09202F	R09201F	Shark Vertical with Lubrication & Depth Control	Vertical	●	●	40 - 900
R09204F	R09203F	Shark Vertical/Horizontal with Lubrication & Depth Control	Vertical/Horizontal	●	●	40 - 900

Interchangeable Speed Modules*

EDP	Description	Capacity		Adapter Size	Max Torque (ft-lb _f)
		Inch	Metric		
R90510F	40RPM Module	1/2" - 1 3/8"	M27 - M36	#3	251
R90520F	75RPM Module	5/16" - 7/8"	M18 - M27	#2	136
R90530F	140RPM Module	5/16" - 3/4"	M18 - M22	#2	70
R90540F	320RPM Module	#0 - 9/16"	M2 - M16	#1	32
R90550F	500RPM Module	#0 - 7/16"	M2 - M12	#1	21
R90560F	900RPM Module	#0 - 5/16"	M2 - M8	#1	11



*Module required for tapping. Arm & module sold separately.

Reach

→ 37"
↑ 26"

Capacity

US: #0 - 9/16"
METRIC: M2 - M14

ROSCAMAT® 200



Series 200 Vertical 350 RPM

Options

- Vertical (V) or Vertical/Horizontal (VH)
- 350 or 750 RPM

EDP	Description	Orientation	Speed RPM	Capacity	
				Inch	Metric
R20001F	Series 200 Vertical 350 RPM	Vertical	350	#0 - 1/16"	M14
R20002F	Series 200 Vertical 750 RPM	Vertical	750	#0 - 3/8"	M10
R20003F	Series 200 Vertical/Horizontal 350 RPM	Vertical/Horizontal	350	#0 - 1/16"	M14
R20004F	Series 200 Vertical/Horizontal 750 RPM	Vertical/Horizontal	750	#0 - 3/8"	M10

Reach

→ 43"

↑ 27"

Capacity

US: #0 - 7/8"

METRIC: M1.6 - M27



ROSCAMAT®

400

Options

- Vertical (V) or Vertical/Horizontal (VH)
- Automatic Lubrication

Series 400 Vertical

EDP	Description	Orientation	Auto Tool Lubrication	Speed RPM
R40000F	Series 400 Vertical	Vertical		90-2100
R41000F	Series 400 Vertical with Lubrication	Vertical	●	90-2100
R44000F	Series 400 Vertical/Horizontal	Vertical/Horizontal		90-2100
R45000F	Series 400 Vertical/Horizontal with Lubrication	Vertical/Horizontal	●	90-2100

Interchangeable Speed Modules*

EDP	Description	Capacity		Adapter Size	Max Torque (ft-lb _r)
		Inch	Metric		
R40510F	90RPM Module	5/16" - 7/8"	M8 - M22	#2	66
R40520F	170RPM Module	5/16" - 5/8"	M8 - M22	#2	58
R40530F	300RPM Module	#0 - 5/16"	M1.6 - M14	#1	32
R40540F	550RPM Module	#0 - 1/2"	M1.6 - M12	#1	18
R40550F	750RPM Module	#0 - 3/8"	M1.6 - M10	#1	13
R40560F	1050RPM Module	#0 - 5/16"	M1.6 - M18	#1	9
R40570F	2100RPM Module	Drill up to 5/16" ø		B16	4



*Module required for tapping. Arm & module sold separately.

Reach

- 88"
- ↑ 44"

Capacity

- US: #0 - 7/8"
- METRIC: M1.6 - M27



ROSCAMAT®

500

Features

- Maximum Reach

Options

- Tap at Any Angle
- Automatic Lubrication

Series 500 Any Angle

EDP	Description	Orientation	Auto Tool Lubrication	Speed RPM
R59100F	Series 500 Vertical	Vertical		90-2100
R59300F	Series 500 Vertical with Lubrication	Vertical	●	90-2100
R59200F	Series 500 RHM Any Angle Manual	Any Angle		90-2100
R59400F	Series 500 RHM-E Any Angle Manual with Lubrication	Any Angle	●	90-2100
R59500F	Series 500 RHC Any Angle Constant	Any Angle		90-2100
R59600F	Series 500 RHC-E Any Angle Constant with Lubrication	Any Angle	●	90-2100

Interchangeable Speed Modules*

EDP	Description	Capacity		Adapter Size	Max Torque (ft-lb.)
		Inch	Metric		
R40510F	90RPM Module	5/16" - 7/8"	M8 - M22	#2	66
R40520F	170RPM Module	5/16" - 5/8"	M8 - M22	#2	58
R40530F	300RPM Module	#0 - 9/16"	M1.6 - M14	#1	32
R40540F	550RPM Module	#0 - 1/2"	M1.6 - M12	#1	18
R40550F	750RPM Module	#0 - 3/8"	M1.6 - M10	#1	13
R40560F	1050RPM Module	#0 - 5/16"	M1.6 - M18	#1	9
R40570F	2100RPM Module	Drill up to 5/16" ø		B16	4



*Module required for tapping. Arm & module sold separately.

MORE EFFICIENT

Take the Guess Work Out of the Process

With Roscamat®USA tapping arms the operator can bring the tap to the work which is 3-4 times more efficient than bringing the work piece to a fixed spindle.

More Efficient Tapping

By utilizing quick change modules and tap adapters the proper speed and torque can be achieved for different tap sizes to improve efficiency and productivity.

HIGHER QUALITY

Less Than a Quarter Turn on a No-Go Gage

Due to the rigidity and precise movement of the Roscamat®USA tapping arm, tapped holes are very high quality and typically gage with a smooth insertion of the go gage and little if any entry of the no-go gage.

INCREASES PRODUCTIVITY

Reduce or Eliminate Tap Breakage

Using quick change torque control tap adapters, the clutch in the adapter ratchets when the tap hits the bottom of the hole, encounters an interference in the hole or when the tap dulls. This prevents tap breakage and allows for the tap to be quickly replaced if needed.

Maximize Manpower

By placing a Roscamat®USA tapping arm next to your machining center, a significant improvement in productivity can be achieved. While the machining center is drilling holes in the next part the operator can be tapping the holes in the previous part. Typically, tapping is the slowest and last operation on a machining center.

Tap Easy.

Small Table



27 1/2" x 27 1/2" x 28"

Mosquito • 200

Medium Table



34 1/2" x 34 1/2" x 28"

Mosquito • Tiger • 200 • 400



U1105A	Standard Adjustable Feet	U1106A
U1108A	Standard Adjustable Feet with Drawer	U1110A
U1000A	Mobile Heavy Duty Casters	U1102A
U1107A	Mobile Heavy Duty Casters with Drawer	U1109A

Knee Table
RA0003F



19 1/16" x 19 1/16" x 35 7/16"

500 x 500 x 900 mm

Mosquito • 200 • 400

Large Table
RA0006F

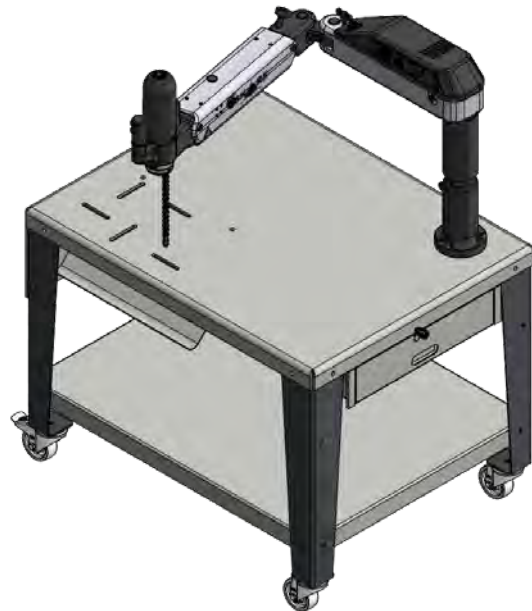

43 5/16" x 33 7/16" x 33 7/16"

1100 x 850 x 850 mm

Mosquito • Tiger • Shark • 200 • 400

Trolley with Column
RA0007F



27 1/16" x 27 1/16" x 35 1/16"

Mosquito • Tiger • Shark • Dragon
200 • 400 • 500

Column
RA0010F



13 3/4" x 13 3/4" x 29 1/2"

Mosquito • Tiger • Shark • Dragon
200 • 400 • 500

Pneumatic Lifter
RA0012F

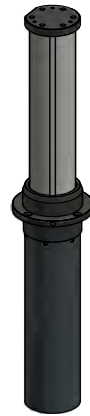

21 5/8"

Mosquito • Tiger • Shark • Dragon
200 • 400 • 500

Small Clamp
RA0001F



5" x 1 1/4"

Mosquito • 200 • 400

Large Clamp
RA0002F



5" x 6 1/4"

Mosquito • Tiger • Shark • Dragon
200 • 400 • 500

2000 Elevator (Pneumatic)
R76096F



27 1/16" x 27 1/16" x 35 1/16"

Mosquito • Tiger • Shark • Dragon
200 • 400 • 500

Magnetic Support
RA0015F

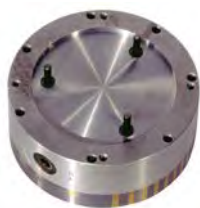

7 7/8" ø

Mosquito • 400

Swing Extensions 1000
RA0035F



39 3/8" x 10 7/8"

Mosquito • Tiger • Shark • Dragon
200 • 400 • 500

HELICOIL® SOLUTION



EDP	Nominal Thread Size	L ₁ mm	L ₂ max mm	L mm	Ø D ₁ mm	Ø D ₂ mm
R76050F	M2X.4	25	9	75	8	8
R76051F	M2.5X.45	25	9	75	8	8
R76052F	M3X.5	30	14	75	8	8
R76053F	M3.5X.6	30	14	75	8	8
R76054F	M4X.7	35	16	75	8	8
R76055F	M5X.8	40	20	80	10	8
R76056F	M6X1.0	40	20	80	11	8
R76057F	M7X1.0	55	30	80	15	8
R76058F	M8X1.25	55	30	80	15	8
R76059F	M8X1.0	55	30	80	15	8
R76060F	M9X1.25	65	40	85	15	8
R76061F	M10X1.5	60	40	85	15	8
R76062F	M10X1.0	65	40	90	16	8
R76063F	M10X1.25	65	40	90	16	8
R76064F	M12X1.75	70	45	90	20	8
R76065F	M12X1.25	70	45	95	20	8
R76066F	M12X1.5	65	45	90	20	8
R76067F	M14X2.0	70	50	95	20	8
R76068F	M14X1.5	70	50	95	20	8
R76069F	M16X2.0	80	55	100	22	8
R76070F	M16X1.5	80	55	100	22	8
R76071F	M18X2.5	90	65	110	24	8
R76072F	M20X2.5	100	70	120	25	8
R76073F	M22X2.5	110	80	130	27	8
R76074F	M24X3.0	120	90	140	30	8
R76075F	UNC 2-56	17	17	88	8	8
R76076F	UNC 4-40	22	22	93	8	8
R76077F	UNF 4-48	22	22	93	6	8
R76077F	UNC 5-40	24	24	92	8	8
R76078F	UNC 6-32	26	26	94	8	8
R76088F	UNF 6-40	44	30	75	8	8
R76079F	UNC 8-32	35	19	75	8	8
R76089F	UNF 8-36	44	30	75	8	8
R76080F	UNC 10-24	49	32	80	9	8
R76090F	UNF 10-32	49	34	80	10	8
R76081F	UNC 12-24	49	32	80	10	8
R76082F	UNC 1/4-20	49	32	80	12	8
R76091F	UNF 1/4-28	49	28	80	12	8
R76083F	UNC 5/16-18	49	32	80	16	8
R76092F	UNF 5/16-24	49	28	80	16	8
R76084F	UNC 3/8-16	59	35	90	16	8
R76093F	UNF 3/8-24	59	37	90	16	8
R76085F	UNC 7/16-14	64	42	95	20	8
R76094F	UNF 7/16-20	64	40	95	20	8
R76086F	UNC 1/2-13	74	48	105	21	8
R76095	UNF 1/2-20	74	58	105	21	8



Designed to make **pneumatic** and **electric** Roscamat®USA tapping arms capable of installing screw thread inserts.

Must be used with an M8 torque control tap adapter.

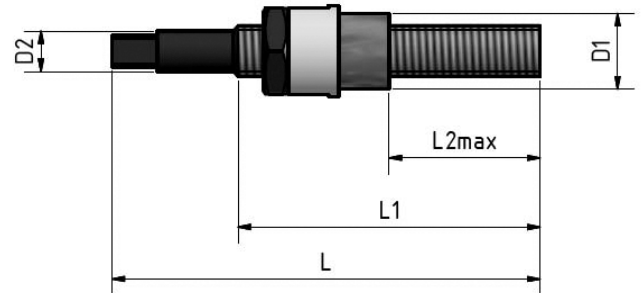

TAP ADAPTERS



Rigid Tap Adapters

Best suited for through holes and in applications where tap breakage is not a concern



Torque Control Adapters

- Best solution for protecting your taps and work pieces from tap breakage
- Best for blind hole tapping and where chip evacuation is a concern

Tap Size		Rigid Tap Adapters						Torque Control Adapters					
ANSI	ISO	Size 1		Size 2		Size 3		Size 1		Size 2		Size 3	
		Part Number	EDP	Part Number	EDP	Part Number	EDP	Part Number	EDP	Part Number	EDP	Part Number	EDP
#0-6	M1.6-M3.5	19/11 4036	R11600B					19/1 4036	R11800B				
# 8	M4	19/11 4041	R11602B					19/1 4041	R11801B				
# 10	M5	19/11 4048	R11604B					19/1 4048	R11802B				
# 12		19/11 4054	R11605B					19/1 4054	R11803B				
1/4	M6	19/11 4063	R11606B					19/1 4063	R11804B				
5/16	M8	19/11 4079	R11607B	31/12 4079	R11614B			19/1 4079	R11805B	31/2 4079	R11811B		
3/8	M10	19/11 4095	R11608B	31/12 4095	R11615B			19/1 4095	R11806B	31/2 4095	R11812B		
7/16	M11	19/11 4111	R11611B	31/12 4111	R11616B			19/1 4111	R11807B	31/2 4111	R11813B		
1/2	M12	19/11 4127	R11612B	31/12 4127	R11617B	48/13 4127	R11627B	19/1 4127	R11808B	31/2 4127	R11814B	48/3 4127	R11825B
9/16	M14	19/11 4142	R11613B	31/12 4142	R11618B	48/13 4142	R11628B	19/1 4142	R11809B	31/2 4142	R11815B	48/3 4142	R11826B
5/8	M16			31/12 4158	R11619B	48/13 4158	R11629B			31/2 4158	R11816B	48/3 4158	R11827B
11/16	M18			31/12 4174	R11620B	48/13 4174	R11630B			31/2 4174	R11817B	48/3 4174	R11828B
3/4				31/12 4190C	R11621B	48/13 4190	R11631B			31/2 4190	R11818B	48/3 4190	R11829B
13/16	M20			31/12 4206C	R11622B	48/13 4206	R11632B			31/2 4206	R11819B	48/3 4206	R11830B
7/8	M22			31/12 4222C	R11623B	48/13 4222	R11633B			31/2 4222	R11820B	48/3 4222	R11831B
15/16	M24					48/13 4238	R11634B					48/3 4238	R11833B
1	M25					48/13 4254	R11635B					48/3 4254	R11834B
1 1/16	M27					48/13 4286	R11636B					48/3 4286	R11835B
1 1/8	M27					48/13 4286	R11636B					48/3 4286	R11835B
1 3/16	M30					48/13 4317	R11637B					48/3 4317	R11836B
1 1/4	M30					48/13 4317	R11637B					48/3 4317	R11836B
1 5/16	M33					48/13 4349	R11638B					48/3 4349	R11837B
1 3/8	M33					48/13 4349	R11638B					48/3 4349	R11837B
1/8 NPT		19/11 4097C	R11609B					19/1 4097C	R11810B				
1/4 NPT				31/12 4131C	R11624B					31/2 4131C	R11822B		
3/8 NPT				31/12 4166C	R11625B	48/13 4166C	R11639B			31/2 4166C	R11823B	48/3 4166C	R11838B
1/2 NPT				31/12 4209C	R11626B	48/13 4209C	R11640B			31/2 4209C	R11824B	48/3 4209C	R11839B
3/4 NPT						48/13 4264C	R11641B					48/3 4264C	R11840B
1 NPT						48/13 4332C	R11642B					48/3 4332C	R11841B



Tap Adapter Extension
R10080F



Reduction Cup

EDP	Size
RA0022F	1 - 0
RA0021F	2 - 1
RA0024F	3 - 1
RA0023F	3 - 2



ER Collet Chuck Adapters

EDP	Size
R11750F	1 - ER16
R11751F	2 - ER25

ROSCAMAT® USA



106 West Ohio Avenue
Mount Vernon, Ohio 43050
phone (800) 991-4225

Customer Commitment

To work hard everyday to be regarded in the metal working marketplace as a supplier that is friendly, helpful and easy to do business with - EVERY DAY, EVERY TIME. To offer innovative high quality solutions at a competitive price. To be receptive & proactive in identifying solutions for our customers' needs & requirements.

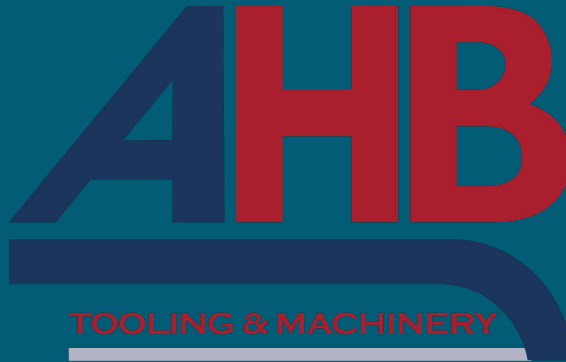

COMPLETE METALWORKING SOLUTIONS

(800) 991-4225

www.ahbinc.com

ISO Certified

customerservice@ahbinc.com

Tap Easy.



Sold on 5 Continents
in 85 Countries

