



SHARP



**Precision machine
tools for the
whole shop.**

All in one place.

Sharp Product Line Card



MILLING MACHINES

- Knee Type Vertical Milling Machines4
- CNC Knee Type Vertical Milling Machines6
- Knee Type Vertical / Horizontal Milling Machines7
- Bed Type Milling Machines8
- CNC Bed Type Milling Machines8
- Bed Type Vertical / Horizontal Milling Machines9
- CNC Bed Type Vertical / Horizontal Milling Machines9



Band Saws

- Vertical Band Saws20
- Manual Horizontal Band Saws21
- Swivel Head Miter Horizontal Band Saws21
- Semi Auto Double Column Horizontal Band Saws23
- NC Horizontal Band Saws23
- NC Double Column Horizontal Band Saws23



Lathes

- High Precision Toolroom Lathes10
- Precision Lathes10
- Heavy Duty Precision Lathes12
- CNC Flat Bed Precision Lathes13
- Large Swing Lathes14
- Extra Large Swing Lathes14
- CNC Big Bore Flat Bed Lathes14



Drills

- Radial Arm Drills24



Grinders

- Manual Surface Grinders16
- Automatic Surface Grinders16
- Fully Automatic Surface Grinders With Micro Processor Downfeed16
- Travelling Column Surface Grinders ...18
- Double Column Surface Grinders18
- Cylindrical Grinders19
- 2 Axis CNC Cylindrical Grinders (FANUC Oi-TF control)19



Vertical Machining Centers

- 3-Axis Linear Roller Pack Way26
- 5-Axis Simultaneous VMC (FANUC 31i-B5 control)26
- Gear Head Box Way VMC27
- Double Column Linear Roller Pack Way28

MILLING MACHINES



KNEE TYPE VERTICAL MILLING MACHINE LMV-42 (Variable Speed)

Table	9" x 42"
Travel	12" x 30"

- 3 HP motor, R-8 spindle
- Variable speed spindle (60-4,500 RPM)
- Hard chromed dovetails ways

Also available: LMV-50 (9" x 50" table, 12" x 37" travel)



KNEE TYPE VERTICAL MILLING MACHINE TMV-DVS (Digital Variable Speed)

Table	10" x 54"
Travel	16.3" x 39"

- 3 HP motor, R-8 spindle
- Variable speed spindle (60-4,500 RPM)
- Hardened and ground boxways, column, base
- One shot lubrication with back flow valve

Also available: "K" Premium package includes 3-axis digital readout, power table and power drawbar



KNEE TYPE VERTICAL MILLING MACHINE LMV-49-DVS (Digital Variable Speed)

Table	9" x 49"
Travel	12" x 36.6"

- 3 HP, R-8 spindle,
- Variable speed spindle (60-4,500 RPM)
- Single phase or 3 phase
- Meehanite casting

Also available: "K" P remium package includes 3-axis digital readout, and power feed table



KNEE TYPE VERTICAL MILLING MACHINE TMV-1 (Variable Speed)

Table	10" x 54"
Travel	16.3" x 39"

- 5 HP motor NT40 spindle
- Variable speed spindle (60-4,500 RPM)
- Box ways on column and saddle
- Hardened and ground table, Turcite coated ways



KNEE TYPE VERTICAL MILLING MACHINE TMV (Variable Speed)

Table	10" x 54"
Travel	16.3" x 39"

- 3 HP motor, R-8 spindle
- Variable speed spindle
- Hardened ground box ways

Also available: "K" Premium package includes 3-axis digital readout, power table and power drawbar



KNEE TYPE VERTICAL MILLING MACHINE V-1 (Digital Variable Speed)

Table	12" x 58"
Travel	16" x 40"

- 5 HP spindle motor, NT40 taper spindle
- Variable speed spindle (70-4,000 RPM)
- Hardened and ground boxways
- Power feed table and saddle



MILLING MACHINES



CNC KNEE TYPE VERTICAL MILLING MACHINE LMV-50-MP-3, (3-Axis Control)



Table	9" x 50"
Travel	11" x 32" x 5"

- 3 HP motor, R-8 spindle
- Acu-Rite Millpwr G2 CNC 3-Axis Control (Longitudinal, Cross and Quill)
- 3-axis Digital Readout System (table, saddle, quill)

Also available:

LMV-42-MP-2, 2-axis Acu-Rite Control (9" x 42" table, 11" x 25" x 5" travel),
LMV-50-MP-2, 2-axis Acu-Rite Control (9" x 50" table, 11" x 32" x 5" travel),
LMV-42-MP-3, 3-axis Acu-Rite Control (9" x 42" table, 11" x 25" x 5" travel),



CNC KNEE TYPE VERTICAL MILLING MACHINE LMV-49-DVS-MP-3, (3-Axis Control)



Table	9" x 49"
Travel	11" x 31.6" x 5"

- 3 HP motor, R-8 spindle
- Acu-Rite Millpwr G2 CNC 3-Axis Control (Longitudinal, Cross, and Quill)
- 3-axis Digital Readout System (table, saddle, quill)

Also available: LMV-49-DVS-MP-2, 2-axis Acu-Rite Control (9" x 49" table, 11" x 31.6" x 5" travel)



CNC KNEE TYPE VERTICAL MILLING MACHINE TMV-MP-3, (3-Axis Control)



Table	10" x 54"
Travel	15.5" x 31" x 5"

- 3 HP motor, R-8 spindle
- Acu-Rite Millpwr G2 CNC 3-Axis Control (Longitudinal, Cross, and Quill)
- 3-axis Digital Readout System (table, saddle, quill)

Also available: TMV-MP-2, 2-axis Acu-Rite control (10" x 54" table, 15.5" x 31" x 5" travel, 3 HP motor)



CNC KNEE TYPE VERTICAL MILLING MACHINE TMV-DVS-MP-3, (3-Axis Control)



Table	10" x 54"
Travel	15.5" x 31" x 5"

- Digital Variable Speed
- 3 HP motor, R-8 spindle
- Acu-Rite Millpwr G2 CNC 3-Axis Control (Longitudinal, Cross, and Quill)
- 3-axis Digital Readout System (table, saddle, quill)

Also available: TMV-DVS-MP-2, 2-axis Acu-Rite Control (10" x 54" table, 15.5" x 31" x 5" travel, 3 HP motor)



CNC KNEE TYPE VERTICAL MILLING MACHINE TMV-1-MP-3, (3-Axis Control)



Table	10" x 54"
Travel	15.5" x 31" x 5"

- 5 HP motor, NT40 taper spindle
- Acu-Rite Millpwr G2 CNC 3-Axis Control (Longitudinal, Cross, and Quill)
- 3-axis Digital Readout System (table, saddle, quill)

Also available: TMV-DVS-MP-2, 2-axis Acu-Rite Control (10" x 54" table, 15.5" x 31" x 5" travel, 3 HP motor)



KNEE TYPE VERTICAL/HORIZONTAL MILLING MACHINE VH-25, (Variable Speed)



Table	10" x 56"
Travel	16.5" x 36"

- 5 HP motor, NT40 vertical and horizontal spindle
- Built-in gear driven table, saddle
- Hardened and ground box ways

MILLING MACHINES



BED TYPE VERTICAL MILLING MACHINE

KMA-3



Table	20" x 87"
--------------	-----------

Travel	24" x 59"
---------------	-----------

- 17.5 HP motor, NT50 taper spindle
- Hardened and ground boxways
- Fixed quill, traveling head

Also available:

KMA-1 (15" x 67" table, 15" x 39" travel, 10 HP motor)



BED TYPE VERTICAL/HORIZONTAL MILLING MACHINE

KMA-3H



Table	20" x 87"
--------------	-----------

Travel	24" x 59"
---------------	-----------

- 17.5 HP motor, NT50 taper spindle
- Vertical head travel 28", fixed quill
- Hardened and ground boxways
- Geared head



BED TYPE VERTICAL MILLING MACHINE

KMA-5



Table	30" x 106"
--------------	------------

Travel	32" x 79"
---------------	-----------

- 17.5 HP motor, NT50 taper spindle
- Hardened and ground boxways
- Fixed quill, traveling head



BED TYPE VERTICAL/HORIZONTAL MILLING MACHINE

KMA-5H



Table	30" x 106"
--------------	------------

Travel	32" x 79"
---------------	-----------

- 17.5 HP motor, NT50 taper spindle
- Vertical head travel 28", fixed quill
- Hardened and ground boxways
- Geared head



CNC BED TYPE VERTICAL MILLING MACHINE

KMA-3-CNC



Table	23.6" x 86.6"
--------------	---------------

Travel	31" x 66.9"
---------------	-------------

- 15 HP motor, NT50 taper spindle
- Fanuc OiMF control and AC servo drives
- 3-axis electronic handwheel (MPG)

Also available:

KMA-1-CNC (19.7" x 74.8" table, 22" x 51.2" travel, 10 HP motor),

KMA-2-CNC (19.7" x 74.8" table, 26" x 59" travel, NT #50 taper, 10 HP motor)



CNC BED TYPE VERTICAL/HORIZONTAL MILLING MACHINE

KMA-3H-CNC



Table	23.6" x 86.6"
--------------	---------------

Travel	41.4" x 66.9"
---------------	---------------

- 15 HP motor, NT50 taper
- Fanuc OiMF control and AC servo drives
- 3-axis electronic hand wheel (MPG)
- Geared head

Also available:

KMA-1H-CNC (19.7" x 74.8" table, 33.5" x 51.2" travel, 10 HP motor),

KMA-2H-CNC (19.7" x 74.8" table, 35.4" x 59" travel, 10 HP motor),

KMA-4H-CNC (27.5" x 102.3" table, 47.3" x 78.7" travel, 15 HP motor)



HIGH PRECISION TOOLROOM LATHE 1118H

Swing 11"

Center Distances 18"

- 5 HP motor, TURCITE coated bedway
- Digital variable speed spindle 4,000 rpm
- High precision spindle 50 millionth TIR



PRECISION LATHE 1440V & 1440V-K

Swing 14"

Center Distances 40"

- 3 HP motor, D1-4 camlock, 1.5" bore
- Digital variable speed drive system
- Hardened and ground chrome-Moly gears
- Steady rest and follow rest

"K" Premium Package includes 2-axis digital readout, Chuck guard w/ limited switch, and Halogen work light



PRECISION LATHE 1340VS & 1340VS-K

Swing 13"

Center Distances 40"

- 3 HP motor, D1-4 camlock, 1.6" bore
- Digital variable speed drive system
- Hardened and ground chrome-moly gears
- Steady rest and follow rest

"K" Premium Package includes 2-axis digital readout, Chuck guard w/limited switch, and Halogen work light



PRECISION LATHE 1640L & 1640L-K

Swing 16"

Center Distances 40"

- 7.5 HP motor, D1-8 camlock, 3.1" bore
- 12 speed, gear head
- One piece Meehanite casting bed
- Steady rest and follow rest

"K" Premium Package includes 2-axis digital readout, Chuck guard w/limited switch, and Halogen work light



Also available:

1660L & 1660L-K (16" x 60", D1-8 camlock, 3.1" bore, 7.5 HP motor)
1860L (18" x 60") 1880L (18" x 80") D1-8 camlock, 3.1" bore, 7.5 HP motor



PRECISION LATHE 1440F & 1440F-K

Swing 14"

Center Distances 40"

- 3 HP motor, D1-4 camlock, 1.5" bore
- 16 speeds, gear head
- Steady rest and follow rest
- Hardened and ground chrome-moly gears

"K" Premium Package includes 2-axis digital readout, Chuck guard w/ limited switch, and Halogen work light



PRECISION LATHE 1640LV & 1640LV-K

Swing 16"

Center Distances 40"

- 7.5 HP motor, D1-8 camlock, 3.1" bore
- Direct selection for inch/metric threads
- One piece Meehanite casting bed
- Steady rest and follow rest

"K" Premium Package includes 2-axis digital readout, Chuck guard w/ limited switch, and Halogen work light



Also available:

1660LV (16" x 60", D1-8 camlock, 3.1" bore, 7.5 HP motor)
1660LV-K (Premium Package)
1860LV (18" x 60", D1-8 camlock, 3.1" bore, 7.5 HP motor)
1880LV (18" x 80", D1-8 camlock, 3.1" bore, 7.5 HP motor)



HEAVY DUTY LATHE 22-B-Series

Swing	22"
Center Distances	40", 60", 80", 100", 120", 160"



- 15 HP motor, D1-11 camlock, 4.5" bore
- Quick change gearbox
- Direct selection for inch / metric threads

Also available: 22-B-Series (22" swing, 40", 60", 80", 100", 160" between center),
26-B-Series (26" swing, 40", 60", 80", 100", 120", 160" between center)



HEAVY DUTY LATHE 30-B-Series

Swing	30"
Center Distances	60", 100", 120", 160"



- 15 HP motor, D1-11 camlock, 4.5" bore
- Quick change gearbox
- Direct selection for inch / metric threads



EXTRA HEAVY DUTY LATHE V-Series

Swing	24" & 30"
Center Distances	80", 100", 120", 160"



- 15 HP motor, D1-11 camlock, 4 1/8" bore
- 18 speed, clutch type gear head
- Multiple leads thread indicator



CNC FLAT BED LATHE 1840TC-F

Swing	18"
Center Distance	40"



- 10 HP motor
- Programmable spindle speed
- FANUC Oi-TF control
- D1-6 camlock, 2.3" spindle bore

Also available: 2060TC-F (20" x 60", D1-8 camlock, 3.4" bore, 10 HP motor)



CNC FLAT BED LATHE 2460TC-F

Swing	24"
Center Distance	60"



- 15 HP motor
- D1-8 camlock, 4.1" spindle bore
- Fanuc Oi-TF CNC, 8.4" LCD screen



CNC FLAT BED LATHE 3060TC-F

Swing	30"
Center Distance	60"



- 20 HP motor
- A2-11, 6.7" spindle bore
- Fanuc Oi-TF CNC, 10.4" LCD screen

Also available with 80", 120" & 160" between centers



LARGE SWING M 24 SERIES



Swing	34", 40", 50", 60", 70"	<ul style="list-style-type: none"> • 30 HP motor • Bed width: 24" • Massive one-piece casting machine base
Center Distances	60"-315"	
Bore Sizes	6", 9", 10", 12", 15"	



EXTRA LARGE SWING M 32 SERIES



Swing	70", 80", 90"	<ul style="list-style-type: none"> • 30, 40, 50 HP motor • Bed width: 32" • Massive one-piece casting machine base
Center Distances	60"-315"	
Bore Sizes	6", 9", 10", 12", 15"	



CNC BIG BORE FLAT BED LATHE - LARGE CAPACITY STA SERIES



Swing	38", 44", 50", 55", 60"	<ul style="list-style-type: none"> • 30, 40, 50 HP motor • Bed width: 24" • Massive one-piece casting machine bedway/base
Center Distances	60"-236"	
Bore Sizes	6", 9", 10", 12", 15"	



CNC BIG BORE FLAT BED LATHE - LARGE CAPACITY STB SERIES



Swing	38", 44", 50", 55", 60", 70", 95"	<ul style="list-style-type: none"> • 30, 40, 50 HP motor • Bed width: 32" • Massive one-piece casting machine bedway/base
Center Distances	60"-236"	
Bore Sizes	6", 9", 10", 12", 15"	



CNC BIG BORE FLAT BED LATHE - LARGE CAPACITY STC SERIES



Swing	38", 44", 50", 55", 60", 70", 95"	<ul style="list-style-type: none"> • 30, 40, 50 HP motor • Bed width: 49" with 6 bedways • Massive one-piece casting machine bedway/base
Center Distances	80"-196"	
Bore Sizes	6", 9", 10", 12", 15"	



CNC BIG BORE FLAT BED LATHE - LARGE CAPACITY STF SERIES



Swing	44", 50", 55", 60", 64"	<ul style="list-style-type: none"> • 30 HP motor • Bed width: 32" • Massive one-piece casting machine bedway/base
Center Distances	40"	
Bore Sizes	6", 9", 10", 12", 15"	



MANUAL SURFACE GRINDER SG-618



Table 6" x 18"

Travel 7" x 19"

- 2 HP spindle motor
- Wire rope table, Turcite
- Hardened and ground leadscrew



AUTOMATIC SURFACE GRINDER SG-618-2A



Table 6" x 18"

Travel 7" x 21.6"

- 2 HP spindle motor
- 2-axis auto (X, Y) hydraulic table feed & automatic crossfeed
- Turcite Coated Ways



FULLY AUTOMATIC WITH MICROPROCESSOR DOWNFEED SG-618-2AN



Table 6" x 18"

Travel 7" x 21.6"

- 2 HP spindle motor
- 3-axis (X, Y, & Z) hydraulic table feed, automatic crossfeed & NC spindle downfeed
- Turcite Coated Ways



AUTOMATIC SURFACE GRINDER SG-820-2A



Table 8" x 20"

Travel 9" x 23.6"

- 2 HP spindle motor
- Slideways are hand scrapped and Turcite Coated
- 2-axis auto (X, Y) hydraulic table feed & automatic crossfeed

Also available: SG-820-2AN with microprocessor downfeed



AUTOMATIC SURFACE GRINDER SH-920-2A



Table 9" x 20"

Travel 11" x 26"

- 3 HP motor
- 2-axis auto (X, Y) hydraulic table feed & automatic crossfeed
- Slideways are hand scrapped and Turcite coated

Also available: SH-920-2AN with microprocessor downfeed



AUTOMATIC SURFACE GRINDER SH-1224-2A



Table 12" x 24"

Travel 14" x 27.6"

- 3 HP motor
- 2-axis auto (X, Y) hydraulic table feed & automatic crossfeed
- Slideways are hand scrapped and Turcite coated

Also available: SH1224-2AN with microprocessor downfeed



AUTOMATIC SURFACE GRINDER SH-1632-2A



Table	16" x 32"
Travel	17.6" x 36"

- 5 HP spindle motor
- Double longitudinal "V" ways and cross "V" ways
- 2-axis auto (X, Y) hydraulic table feed & automatic crossfeed

Also available: SH 1632-2AN with microprocessor downfeed
SH-1224-2A (11.6" x 23.6" table, 14" x 27.6" travel, 3 HP motor)
SH-1632-2A(15.8" x 32" table, 17.6" x 36" travel, 3 HP motor)



TRAVELLING COLUMN SURFACE GRINDER SHT-2040-2A



Size	20" x 40" – 24" x 87"
-------------	-----------------------

- 10 HP motor, Auto feed on longitudinal and cross
- Column moves on cross travel
- Optional NC downfeed system

Also available:

SHT-2047-2A (20" x 40" table, 21" x 45" travel 10 HP motor),
SHT-2060-2A (20" x 59" table, 21" x 65" travel 10 HP motor),
SHT-2447-2A (24" x 47" table, 25" x 53" travel 10 HP motor),
SHT-2460-2A (24" x 59" table, 25" x 65" travel 10 HP motor),
SHT-2487-2A (24" x 87" table, 25" x 92" travel 10 HP motor)



DOUBLE COLUMN SURFACE GRINDER SHDC-40160



Table	39.4" x 157.5"	• 25 HP motor, Spindle head motor
Travel	47.2" x 163.4"	• Hydraulic table movement • Servo driven cross travel with ball screw

Also available:

SHDC-40120 (39.4" x 118.1" table, 47.2" x 124" travel, 25 HP motor),
SHDC-4780 (47.2" x 78.7" table, 55" x 84.6" travel, 25 HP motor)



CYLINDRICAL GRINDER OD-820-HE (Manual)



Size	8" max diameter, 20" length
-------------	-----------------------------

- 3 HP spindle motor
- Turcite Way
- Manual wheel head infeed
- MT3 taper

Also available: 5C spindle



CYLINDRICAL GRINDER OD-820-SE (NC)



Size	8" max diameter, 20" length
-------------	-----------------------------

- 3 HP motor
- 2-way auto (longitudinal and cross)
- Optional NC downfeed with ballscrew and servo feed
- MT3 Taper

Also available: 5C spindle



2 AXIS CNC CYLINDRICAL GRINDER (FANUC Oi-TF CONTROL) OD-1524-2X



Max grinding diameter	15"
Distance between centers	24"

- 7.5 HP motor, FANUC Oi-TF CNC control
- X axis is equipped with linear scale with 0.00001" resolution for high precision movement
- Grinding wheel has constant surface speed function

Also available: OD-1320-2X (Max grinding diameter 12.6" distance between centers 20", 7.5 HP motor)



VERTICAL BAND SAW SWV-1209

Table	19.6" x 19.6"
Capacity	11" x 7.8"

- 1 HP motor
- Built in blade welder, grinder, and shear
- Tungsten carbide tipped blade guides for extended life and accuracy of cut



VERTICAL BAND SAW SWV-1614

Table	23.6" x 19.7"
Capacity	15.7" x 13.8"

- 1 HP motor, infinite variable speed inverter drive
- Built in blade welder, grinder and shear
- Tungsten carbide tipped blade guides for extended life and accuracy of cut



VERTICAL BAND SAW SWV-2013

Table	23.6" x 19.6"
Capacity	19.7" x 13"

- 2 HP motor
- Built in blade welder, grinder and shear
- Tungsten carbide tipped blade guides for extended life and accuracy of cut



MANUAL HORIZONTAL BAND SAW SW-80

Round	8"
Square	7" x 7"
Rectangle Capacity	7" x 11.4"

- 1 HP motor, 660 lbs.
- Carbide saw guides for long life and accurate cutting.
- Recirculating coolant system



SWIVEL ARM MITER HORIZONTAL BAND SAW SW-100H

Round	10"
Square	9" x 9"
Rectangle Capacity	9" x 11.8"

- 2 HP motor, 1276 lbs.
- Semi Automatic Cutting Action
- Hydraulic Vise Clamping
- Carbide saw guides for long life and accurate cutting



SWIVEL ARM MITER HORIZONTAL BAND SAW SW-100T

Round	10" round, 7.5" at 90°
Square	10" x 10" (6.9" x 6.9" at 90°)
Rectangle Capacity	9" x 15.7" (6" x 8" at 45°)

- 2 HP motor, 1408 lbs.
- Semi automatic cutting action
- Saw head frame swivel 0 to 60 degrees





SWIVEL ARM MITER HORIZONTAL BAND SAW SW-130HT

Round	13"
Square	11" x 11"
Rectangle Capacity	10.6" x 18"



- 3 HP motor, 1848 lbs.
- Semi Automatic Cutting Action with hydraulic vise clamping
- Saw head frame swivel 0 to 60 degrees



SWIVEL ARM MITER HORIZONTAL BAND SAW SW-165 HT

Round	16.5"
Square	11" x 11"
Rectangle Capacity	15" x 25.6" at 90°



- 5 HP motor with infinite variable speed inverter drive, 3,300 lbs
- Semi Automatic Cutting Action with hydraulic vise clamping
- Saw head frame swivel 0 to 60 degrees



SWIVEL ARM MITER HORIZONTAL BAND SAW SW-100A

Round	10"
Square	10" x 10"
Rectangle Capacity	10" x 11"



- 3 HP motor with infinite variable speed inverter drive, 3080 lbs.
- Hydraulically activated full stroke vise clamping, with a 15.9" single stroke index
- 1 1/4" Wide Saw Blade For Fast Accurate Cutting

Also available:

- SW-120A (12" round, 12" square, 13.4" x 12" rectangular, 5 HP motor),
- SW-126AD (12.6" round, 12.6" square, 12.6" x 15" rectangular, 5 HP motor)

SEMI AUTO DOUBLE COLUMN HORIZONTAL BAND SAW SW-220-SA

Round	22"
Rectangle Capacity	31.5" x 22"



- 10 HP motor, infinite variable inverter drive
- Hydraulic lift and 3 roller material positioner
- Programmable logic controller for all electronic & hydraulic functions

Also available in size ranges from 11" -51" diameter round capacity and up to 20 HP drive



NC HORIZONTAL BAND SAW SW-120NC

Round	12"
Square	12" x 12"
Rectangle Capacity	12" x 13.4"



- 5 HP motor
- NC operating panel with touch screen
- Full stroke hydraulic vice clamping

Also available:

- SW-100NC (10" cutting capacity, 3 HP motor),
- SW-180NC (18.5" cutting capacity, 7.5 HP motor)
- SW-310NC (31.5" cutting capacity, 10 HP motor)



NC DOUBLE COLUMN HORIZONTAL BAND SAW SW-126-NCD

Round	12.6"
Square	12.6" x 12.6"
Rectangle Capacity	12.6" x 15"



- 5 HP motor
- NC operating panel with touch screen
- Double column hydraulic saw frame with heavy duty ball joint for powerful down feed

Also available:

- SW-170NCD (16.5" cutting capacity, 5 HP motor)
- SW-240NCD (24.4" cutting capacity, 10 HP motor)



RADIAL ARM DRILL RD-820

Column Diameter 8.29"

- 3 HP motor, MT4 spindle
- 33.46" column to spindle center
- Arm elevation and clamping for column and gearbox controlled by electric motor



RADIAL ARM DRILL RD-2000

Column Diameter 17"

- 7.5 HP motor, MT5 spindle
- 78.74" column to spindle center
- Arm elevation controlled by hydraulic motor



RADIAL ARM DRILL RD-1230

Column Diameter 12"

- 5 HP motor, MT4 spindle
- 48.5" column to spindle center
- Arm elevation and clamping for column and gearbox controlled by electric motor



RADIAL ARM DRILL RD-2500

Column Diameter 22"

- 10 HP motor, MT6 spindle
- 98.42" column to spindle center
- Arm elevation controlled by hydraulic motor

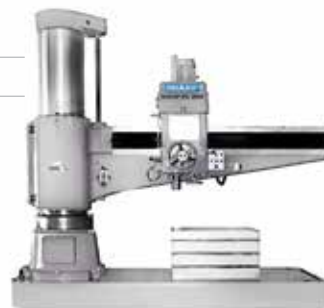

RADIAL ARM DRILL RD-1600

Column Diameter 17"

- 7.5 HP motor, MT5 spindle
- 63" column to spindle center
- Arm elevation controlled by hydraulic electrical, clamping for column and gearbox by hydraulic motor



VERTICAL MACHINING CENTERS



LINEAR ROLLER PACK WAY SVL-2517-SXF

Travel 25.2" x 16.9" x 18.1"

- 10/15 HP motor
- Worktable 27.5" x 16.5"
- FANUC Oi-MF. 8.4" color LCD, with positioning accuracy: X/Y/Z (+/- 0.0002")
- CAT 40 dual contact, 12,000 rpm spindle



GEAR HEAD BOX WAY VMC SVG-6336A-F

Travel 63" x 35" x 28"

- 35 HP motor, 50 taper, 32 position ATC, 4 box ways, 6 box ways
- FANUC Oi-MF, 10.4" LCD
- CTS prepped, 4th axis prepped



Also available models with 87" x 43", and 99" X 43" table travels SVG-8743 A-F and SVG-9943 A-F



5 AXIS SIMULTANEOUS VMC SVX-300-F

Travel 30" x 23.6" x 19.7"

- 5-axis simultaneous contouring
- FANUC 3li-B5 with Positioning Accuracy: X/Y/Z (+/- 0.00006")



DOUBLE COLUMN LINEAR ROLLER PACK WAY SDC-126

Travel 126" x 47.2" x 31.7"

- 30, 35 HP motor, #50, 6,000rpm, 24,32,40 tools linear roller pack ways
- FANUC Oi-MF control
- Table can accommodate up to 10,000 lbs loads with rapid feeds up to 787 inches per minute



5 AXIS SIMULTANEOUS VMC SVX-500-F

Travel 31" x 23.6" x 19.7"

- 5-axis simultaneous contouring
- FANUC 3li-B5 with Positioning Accuracy: X/Y/Z (+/- 0.00006")



DOUBLE COLUMN LINEAR ROLLER PACK WAY SDC-205

Travel 204.7" x 141.7" x 39.3"

- 30, 35 HP motor, #50, 6,000rpm, 24,32,40 tools linear roller pack ways
- FANUC Oi-MF control
- Table can accommodate up to 44,000 lbs loads with rapid feeds up to 394 inches per minute





SHARP-INDUSTRIES

3501 Challenger Street
Torrance, CA 90503

Email: info@sharp-industries.com

Parts: parts@sharp-industries.com

Sales: sales@sharp-industries.com

Service: service@sharp-industries.com

www.sharp-industries.com

AUTHORIZED DEALER



COMPLETE METALWORKING SOLUTIONS

(800) 991-4225

www.ahbinc.com

ISO Certified

customerservice@ahbinc.com

Please contact your local dealer for more details.
We reserve the right to modify product specifications
without prior notice. © 2023 Sharp Industries, Inc.