



COMPLETE METALWORKING SOLUTIONS
(800) 991-4225 www.ahbinc.com
ISO Certified customerservice@ahbinc.com

EV PRESS BRAKES • AB PRESS BRAKES • SHEARS • PRESSES



Model AB Conventional Press Brakes
(+,- .001" ram repeatability)



Guillotine Shears



Y1-Y2 Model EV Precision Brakes
(+,- .0004" ram repeatability)



4 Column Presses



C-Frame Presses



Straightening Presses



Straight Side Presses



AB Conventional Press Brakes

Standard Industrial Corporation
1410 Industrial Park Drive
Clarksdale, MS 38614
United States of America

- The most reliable press brake available. Made in the USA with an unparalleled 5 year parts/1 year CNC warranty + 5 year limited onsite labor warranty.
- Available with either simple mechanical ram control and/or state of the art CNC providing all aspects of forming for all levels of fabrication and sophistication requirements.
- Off the shelf, non-proprietary components means no more over-priced, single source buying from one manufacturer.
- With service all over the United States and multiple parts sources all over the world, you will never again have to wonder where your support is coming from.

MODEL AB PRESS BRAKES



FULL TONNAGE FULL LENGTH OF BED
 +
 FULL TONNAGE OFF-CENTER LOADING

**All Press Brakes are available optionally with up to 8 axis CNC control including 2D and 3D graphics.



A WARRANTY ONLY A REAL AMERICAN MACHINE CAN OFFER

5 YEAR PARTS/1 YEAR CNC WARRANTY
+
5 YEAR LIMITED ONSITE LABOR WARRANTY



LIFETIME PARTS AVAILABILITY



Every component on this machine is available from your local suppliers giving you a lifetime of parts from anywhere in the U.S.A.

3 POINT GIBBING/GUIDANCE SYSTEM

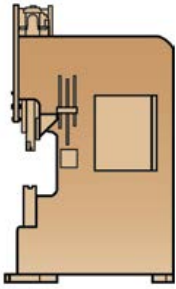

One of the true advantages of the Standard drive system is our ability to provide full tonnage across the bed and ram and not create excessive side loads. This is accomplished because all forces are vertical above the ram centerline and are fully contained within the extremely heavy duty “box” structure. This structure houses the drive system and our impressive 3 point ram guidance/gibbing system.

The front to back forces are controlled with our precision machined set of “ways” combined with extremely heavy duty slides. These ways and guides are located both front and back of the ram and at both ends of the ram. The third set of gibbs is our innovative and very formidable center thrust gibb. This impressive gibbing system is self-aligning and requires no operator action during ram alignment. All three sets of gibbs control the front to back and left to right forces providing the precision $\pm .001$ ” ram repeatability.

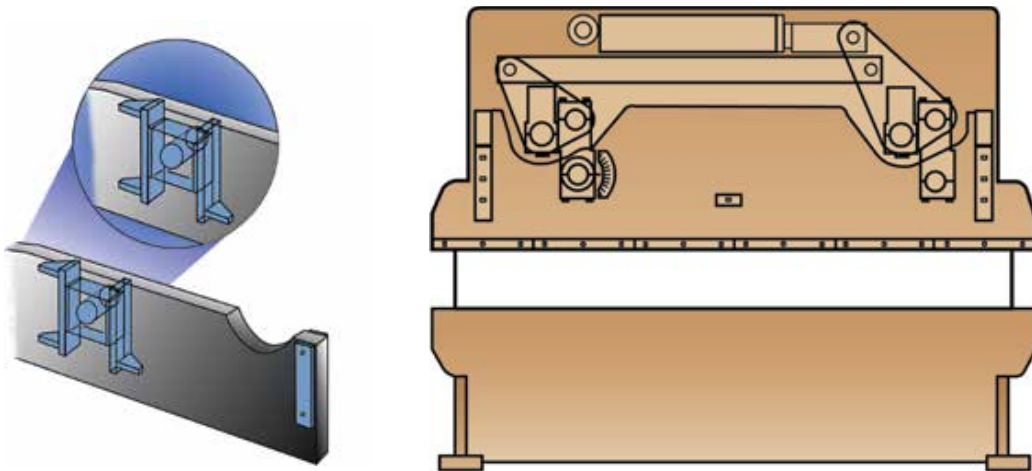

OUR BRAKES ARE SPECIFICALLY DESIGNED FOR THE FOLLOWING APPLICATIONS

FULL LENGTH BENDS where full tonnage across the bed is required for the truest bends

OFF-CENTER LOADING especially when needing substantial tonnage near the ends of the brake

CENTER LOADING when any amount of tonnage is required in the center or anywhere across bed

MULTIPLE DIE SET-UPS across the bed that require the same or varying amounts of tonnage

PUNCHING APPLICATIONS great for punching alone or combined with forming.

SHORT PIECE WORK with some of the fastest ram speeds, your small piece work is done quickly, easily with precision

SINGLE CYLINDER

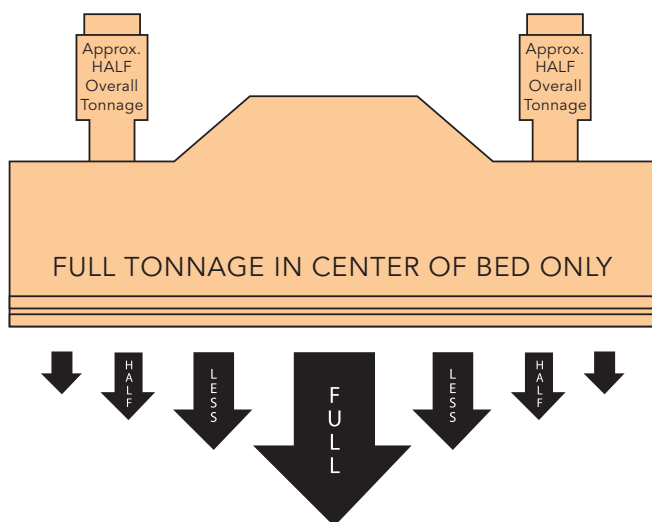
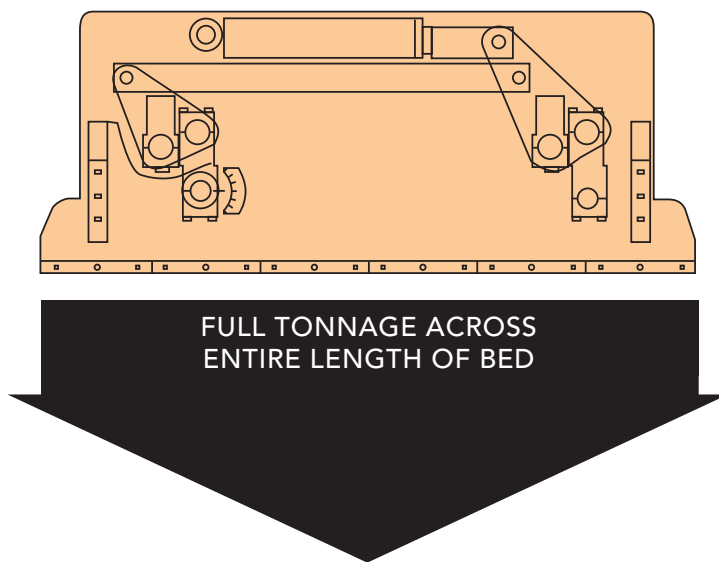

DUAL CYLINDER

ONE CYLINDER SYSTEM

The single cylinder hydra-mechanical drive system is the only system that provides full tonnage across the entire length of the bed and ram. Two cylinder drive systems cannot provide full tonnage across the bed because each cylinder only generates just over 1/2 of the machines overall tonnage.

TWO CYLINDER SYSTEM

The further the application gets away from the center of the bed, the less amount of tonnage is generated. For this reason most 2 cylinder machines require crowning units to compensate for this lack of tonnage and/or they open up their v die openings beyond the industry standard widths because their machines do not have the proper tonnage.

MODELS AND SPECIFICATIONS

(Specifications subject to change)

STANDARD PRESS BRAKES ARE AVAILABLE IN 100, 150, 200, 250, 325, 400, 500, 600, 700 & 1,000 TON CAPACITIES AND UP TO 24' IN LENGTH.

Model	Forming/ Punching	Bed Length	Bed Hsgs.	Open Ht	Stroke	Throat Depth	Weight (Lbs.)
AB100-6	100/66	6'	4'-5"	13"	6"	6"	12,000
AB100-8	100/66	8'	6'-5"	13"	6"	6"	19,000
AB100-10	100/66	10'	8'-5"	13"	6"	6"	19,000
AB100-12	100/66	12'	10'-5"	13"	6"	6"	21,000
AB100-14	100/66	14'	12'-5"	13"	6"	6"	26,000
AB100-16	100/66	16'	14'-5"	13"	6"	6"	32,000
AB100-20	150/66	20'	18'-5"	13"	6"	6"	50,000
AB150-8	150/100	8'	6'-5"	13"	6"	6"	19,000
AB150-10	150/100	10'	8'-5"	13"	6"	6"	22,000
AB150-12	150/100	12'	10'-5"	13"	6"	6"	25,000
AB150-14	150/100	14'	12'-5"	13"	6"	6"	31,000
AB150-16	150/100	16'	14'-5"	13"	6"	6"	38,000
AB150-20	150/100	20'	18'-5"	13"	6"	6"	72,000



AB100-6



AB200-12

Model	Forming/ Punching	Bed Length	Bed Hsgs.	Open Ht	Stroke	Throat Depth	Weight (Lbs.)
AB200-12	200/135	12'	10'-5"	14"	8"	10"	28,000
AB200-14	200/135	14'	12'-5"	14"	8"	10"	45,000
AB200-16	200/135	16'	14'-5"	14"	8"	10"	50,000
AB200-20	200/135	20'	18'-5"	14"	8"	10"	85,000

Model	Forming/ Punching	Bed Length	Bed Hsgs.	Open Ht	Stroke	Throat Depth	Weight (Lbs.)
AB250-12	250/165	12'	10'-5"	16"	8"	10"	28,000
AB250-14	250/165	14'	12'-5"	16"	8"	10"	50,000
AB250-16	250/165	16'	14'-5"	16"	8"	10"	56,000
AB250-20	250/165	20'	16'-5"	16"	8"	10"	85,000



AB250-12

SIMPLE MATH



AB325-12

Standard Industrial 5 Year Parts Warranty is based on a 24 Hour workday which equals:

43,800 HOURS OF WARRANTY

Compared to a typical 1 year warranty we **Exceed** them by:

35,040 HOURS

Compared to a 2 year parts warranty based on an 8 hour work day we **Exceed** them by:

37,960 HOURS

NO OTHER PRESS BRAKE CAN MATCH OUR DEPENDABILITY OR OUR WARRANTY



AB325-14

Model	Forming/ Punching	Bed Length	Bed Hsgs.	Open Ht	Stroke	Throat Depth	Weight (Lbs.)
AB325-12	325/230	12'	10'-5"	16"	8"	10"	40,000
AB325-14	325/230	14'	12'-5"	16"	8"	10"	58,000
AB325-16	325/230	16'	14'-5"	16"	8"	10"	66,000
AB325-20	325/230	20'	18'-5"	16"	8"	10"	95,000

COMPLETE PARTS BILLS OF MATERIALS IN MANUAL WITH ORIGINAL MANUFACTURER'S PART NUMBER SO YOU WILL ALWAYS BE ABLE TO FIND PARTS

AB400-14



Model	Forming/ Punching	Bed Length	Bet Hsgs.	Open Ht	Stroke	Throat Depth	Weight (Lbs.)
AB400-12	400/265	12'	10'-5"	20"	10"	10"	58,000
AB400-14	400/265	14'	12'-5"	20"	10"	10"	67,000
AB400-16	400/265	16'	14'-5"	20"	10"	10"	80,000
AB400-20	400/265	20'	16'-5"	20"	10"	10"	100,000

Model	Forming/ Punching	Bed Length	Bet Hsgs.	Open Ht	Stroke	Throat Depth	Weight (Lbs.)
AB500-12	500/330	12'	10'-5"	20"	10"	10"	70,000
AB500-14	500/330	14'	12'-5"	20"	10"	10"	80,000
AB500-16	500/330	16'	14'-5"	20"	10"	10"	87,000
AB500-20	500/330	20'	16'-5"	20"	10"	10"	100,000



AB500-12

5 YEAR LIMITED LABOR WARRANTY

OUR STANDARD 5 YEAR LIMITED LABOR WARRANTY GUARANTEES IF ANY PROBLEM CANNOT BE IDENTIFIED VIA TELEPHONE AND TROUBLESHOOTING HAS BEEN EXHAUSTED, WE WILL SUPPLY A TECHNICIAN AT YOUR FACILITY AT NO CHARGE FOR 5 YEARS.

SIMPLY THE BEST WARRANTY AVAILABLE

AB600-14



AB700-14



Model	Forming/ Punching	Bed Length	Bed Hsgs.	Open Ht	Stroke	Throat Depth	Weight (Lbs.)
AB600-12	600/400	12'	10'-5"	20"	10"	10"	87,000
AB600-14	600/400	14'	12'-5"	20"	10"	10"	97,000
AB600-16	600/400	16'	14'-5"	20"	10"	10"	108,000
AB600-20	600/400	20'	16'-5"	20"	10"	10"	150,000

Model	Forming/ Punching	Bed Length	Bed Hsgs.	Open Ht	Stroke	Throat Depth	Weight (Lbs.)
AB700-14	600/400	12'	12'-5"	24"	12"	10"	112,000
AB700-16	600/400	14'	14'-5"	24"	12"	10"	135,000
AB700-20	600/400	16'	16'-5"	24"	12"	10"	180,000
AB1000-14	1000/660	14'	12'-5"	24"	12"	10"	160,000
AB1000-16	1000/660	16'	14'-5"	24"	12"	10"	170,000
AB1000-20	1000/660	20'	16'-5"	24"	12"	10"	195,000

All Standard press brakes are designed meet O.S.H.A and ANSI B11.3 standards and comes complete with J.I.C. type listed electrical components.

STANDARD FEATURES

5 YEAR PARTS + 5 YEAR LIMITED LABOR + 1 YEAR CNC/PLC WARRANTY

Every Standard machine is equipped with our unmatched 5 year parts warranty. This warranty includes a 5 year limited onsite labor warranty and a 1 year CNC/PLC Warranty. Unlimited lifetime telephone support is included at no charge. If during the first 5 years you have an unresolved issue and telephone troubleshooting has been fully exhausted we will provide onsite labor to take care of the problem. This warranty is based on 3 shifts a day and 24 hour days. Every machine is also available with our optional **7 Year Extended Warranty** that extends the parts warranty by 2 years.

MECHANICAL IN-LINE DEPTH STOP

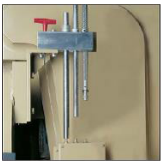

The in-line depth stop is equipped on every base Standard press brake. Simple, precise mechanical limit switches to control open height, speed change point and a micrometer adjustment to achieve precision angles.

This insures NO down time due to computer failure. Available optionally with Esa controls if requested.

EXTREMELY HEAVY-DUTY BED WITH AMERICAN STYLE DIE GROOVE

Incredibly heavy duty lower beams are essential to any well made press brake. Every Standard brake is equipped with a groove in the center of the bed to hold your American style tooling plus Standard prides itself on having the least amount of deflection of any press brake on the market. Less Deflection = Longer Tool & Machine Life

HAND/FOOT SAFETY SEQUENCE WITH FOOTSWITCH

O.S.H.A. approved 2 hand pedestal control with 3 position, footswitch. Use the 2 hand pedestal control during fast approach speed. Once at the pressing speed, the operator can take over with the footswitch and be hands free.

HYDRAULIC PRESSURE TONNAGE CONTROL

Tonnage can be pre-set as required with a simple tonnage control system and gauge.

24" WORK SUPPORT ARMS

Heavy duty 24" work support arms are standard on all brakes. Each arm bolts up to front of press brake bed or can slide left to right across front edge of bed with optional t-slot.

MANIFOLD CENTRALIZED LUBRICATION SYSTEM

Each brake is equipped with our efficient manifold lube system that brings all lubrication points to one easily accessible area.

AMERICAN STYLE HEAVY DUTY RAM CLAMPING

Extremely heavy duty, spring loaded die clamps for easy, fast die change. Accepts all American style standard and precision style tooling. All press brakes can be ordered with Wila (or equiv.) style quick-change powered ram clamping systems and European clamping systems in lieu of manual system.

SIMPLE AND PRECISE RAM TO BED LEVEL ADJUSTMENT

Primarily for realignment of dies and off-center loading applications. Change level as needed in seconds. Manual adjustment is standard up to 325 tons and power adjustment is standard from 400 tons and up.

OPTIONAL FEATURES

7 YEAR PARTS WARRANTY

This package includes:

- A 7 year parts warranty in lieu of standard 5 year parts warranty
- A 1 year PLC and CNC warranty
- A 5 year onsite limited labor warranty: In the event of a problem the customer will be required to help troubleshoot over the phone. If the problem cannot be diagnosed and troubleshooting has been exhausted, Standard will send in a technician at no charge to resolve the situation during the entire 5 year warranty.

OPERATIONAL PREFERENCE CONTROLS

Additional Pedestal and/or Footswitch Control —One pedestal and Footswitch control are standard on all press brakes. This option makes it safe for up to (2) operators to run the machine at the same time.

Auto Return of Ram—Normal operation allows ram to return after pedestal/footswitch is released. This option makes the ram return automatically once cycle is complete even if footswitch is still depressed.

Decompression System—Time-delay system required for bottoming applications

Low Speed Retract —Slows the ram return speed considerably for large material handling. Typically for press brakes 400 tons and above with large flange work.

Power Ram Tilt — Standard on 400 tons and larger and optional on 325 and below. Quick and easy adjustment allows up to $\pm 1/8$ " of the centerline.

Four Position In-Line Depth Stop —Simple, NON-COMPUTERIZED mechanical ram control that allows you to pre-set up to 4 different depths/angles that are selected from your pedestal via a selector switch.



SAFETY FEATURES AND CONTROLS

Light Curtain Safety Barrier—Infra-red light curtain across the front of press brake coupled with physical side barriers protects the operator. Tapeswitch and Merlin curtains are available as well as customer preference.

Laser Guarding Systems—State of the art laser systems wrap around punch to allow operator closer proximity to pinch-point and still be OSHA approved. Not recommended for punching/bottoming applications.

Interlocking Physical Barriers/Cages—Heavy duty, enclosed physical barriers do not allow access to rear of press brake. Interlocking gates shut machine down when opened.

Compliance Options—U.L. Listing, CSA and ZED compliance are available optionally. All parts on the machines are U.L. listed. Contact factory for other compliance options.

OPTIONAL FEATURES

High Speed Hydraulics Packages—All press brakes are available with high speed packages to increase productivity. Each system is equipped with oil cooler to maintain proper temperature and increase system longevity. Contact the factory for typical systems or customized systems per your special needs.

Automatic Lubrication System Air operated, timed system that automatically brings grease to all lubrication points (except backgauge screws). A great option for multiple shift operations. Manifold centralized lubrication system is standard on all brakes.

Support Arms, Quick-Release Systems and Sheet Followers

T-Slot across Front Edge of Bed—5/8" t-slot across front edge of bed to allow work support arms to slide left to right across full length.

Gravity Stops for T-Slot Support Arms—Precision machined stops for t-slots that allow work piece to slide over the top of slide but not backward.

24", 36" or 48" Heavy Duty T-slot Support Arms—Work support, bolt-down, arms with precision machined t-slotted bars to place gravity or other stops in for front gauging. Available with embedded scale. NOTE: Each brake comes standard with (2) non-t-slotted work support arms.

Quick-Change Linear Work Support System Heavy duty, quick-release style work support arms equipped with smooth transition rollers and precision machined ways. Vertical and horizontal adjustments allow precision control for rapid set-up.



CNC Sheet Assist Support Systems—Controlled by a CNC controller, these heavy duty material assists rise and lower with the ram movement. Portable and precise, the circular arc of the arms follows the part being formed. This system not only provides your operator with a level of assistance but the quality of bend will benefit from the following action.



Non-CNC Sheet Assist/Followers—Durable and more economical than the CNC versions, these portable sheet followers hold up to 425 lbs and can be moved quickly and easily.

Ram and Bed Modifications—Customization to Fit Your Needs

Removable Angle Flanges—Utilize your machine both as a press brake and as a press by extending the width of your bed for wider press die configurations. With Standard's ability to provide full tonnage across the bed you can use the machine in straight side and other press type applications

Permanent Bed and/or Ram Flanges—Choose from a wide variety of permanent bed and ram flanges to economically use a press brake for pressing applications.

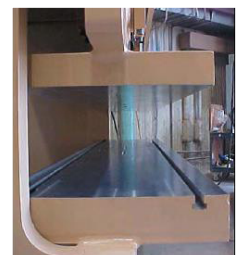

Extra Open height-- Extra Stroke Length--Extra Throat Depth

Horn Extensions—Lengthens bed and ram length without lengthening distance between housings.

Wila Tooling, Crowning, Clamping and Accessories



Crowning Because the Standard AB series brake has the rare ability to provide full tonnage all across the length of the bed crowning is very rarely required. Certain applications such as a set-up on one end of the brake and the exact same set-up on the other end of the brake when identical results are required, a crowning unit can be desirable.

All of our press brakes are available with Wila crowning units.

- Manual & Hand cranks with readers for precision adjustment in seconds
- **CNC crowning with 630, 640 or 660 controls is available**
- Optional clamps for 4 way dies
- Adjustment screws every 8" for variances in bed and fine adjustment
- Built in clamping bars which automatically center and align single V dies



American and New Standard Precision Tooling

- Precision ground to +/- .0004" & hardened at wear points to Rockwell 60
- Segmented to allow for any length bending
- American precision tooling can fit any American style tool holder



Conventional Tooling—Adjustable, conventional, four way, single V plus all other die requirements available with model AB press brakes



Automec Non-CNC and Simple CNC Gauging



Simple Go-To X axis power backgauge—Super basic Go-To control with heavy duty 24" travel (optional 48") with 9 job pre-set capability. Great in conjunction with optional Four position in-line depth stop giving non CNC control of the gauge and ram depth.

CNC300 2-3 axis CNC gauging—Purposely basic with single line display (no graphics), this control gives you complete CNC control of the ram and gauge with little training time required. 300 programmable jobs. Perfect for the customer who wants 2-3 axis control in as simple a format as possible.

(Automec is unrelated to the 630, 640 or 660 controls and gauging)

CNC CONTROLS AND GAUGING

630 with Tooling Graphics

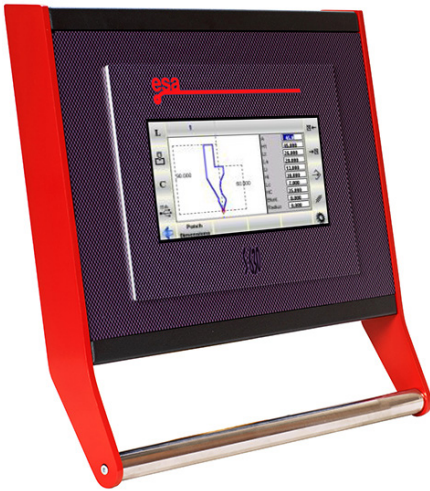

- 10" color touchscreen with pendant mount
- 2D tooling graphics for easy tool programming
- Available w/ 2D offline programming software
- Thousands of hard drive job storage + unlimited off-line storage via USB port
- Available w/ Y + X + R + CNC crowning axis Programmability
- Extensive 2D graphical tooling library
- Programmable delay and retract at pinch point
- Inch/ Metric conversion
- Onsite training included

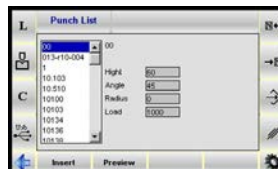

An extensive tooling library allows for easy editing and programming of punches and dies.

Also Included with the 630, 640 and 660 controls are

- Auto return of ram
- Low speed retract of ram
- Decompression for bottoming applications

Radan for 3D programming is available for either your PC and/or the 660 control. State of the art software allowing the import of all range of file formats and automatic unfolding of your parts. Radan parameters can be downloaded to the 630 and 640.

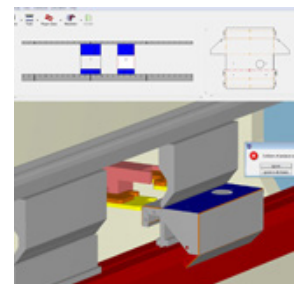

640 with full 2D Part Forming Graphics



- 15" color touchscreen with pendant mount
- Full 2D graphical control with 3D simulator
- Optional Crowning correction in degrees
- 2D identification of best bending sequences
- Includes 2D graphical offline programming software
- 2D collision detection
- 30,000 hard drive programs plus unlimited job storage via USB and/or Ethernet
- Available w/Y + X + R + Z1-Z2 + CNC crowning axis Programmability
- Includes: Auto return of ram + Low speed retract + Decompression
- Programmable delay and retract at pinch point
- Inch/ Metric conversion
- Onsite training included

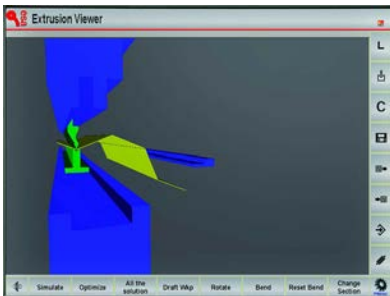

640 3D part simulator

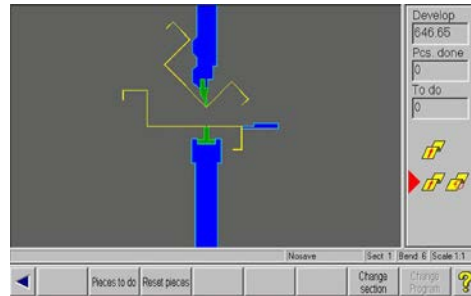

640 Step by step part forming walkthrough

660 with full 3D Graphics

(RADAN fully compatible) also available for complete 3D graphics and modeling and is required for X Prime axis as well as Z1-Z2+X1-X2+R1-R2 axes.

- 15" color touchscreen with pendant mount
- Embedded Windows operating system
- Full 3D capability



Super Heavy Duty, Precision Servo Gauges from 2 - 6 Axis

X only or X + R Axis

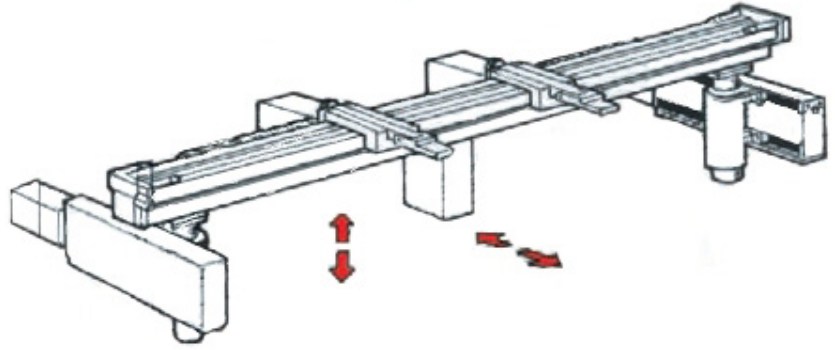

All backgauges are Low Profile with the fingers being the tallest component allowing easier material positioning

X + R + Z1-Z2 Axis

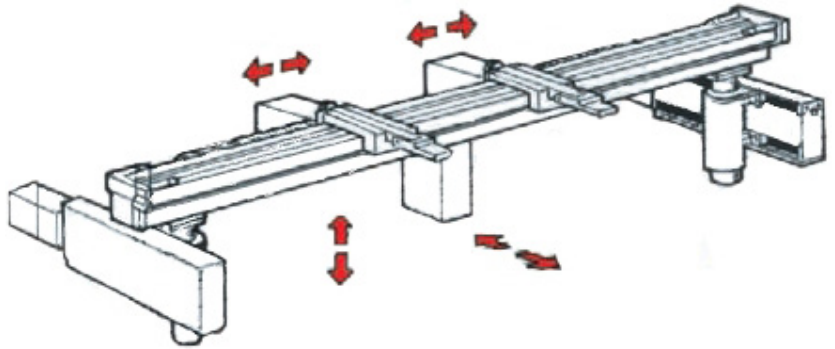

All backgauges are covered by our 5 year parts warranty with off the shelf readily available components

X + R + Z1-Z2 + X Prime Axis

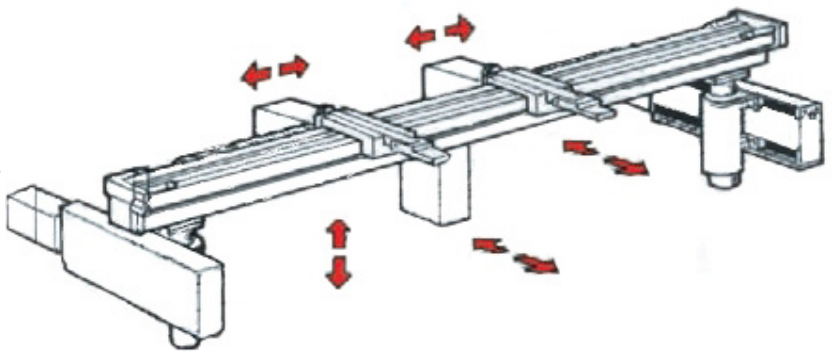

All backgauges are available for 100 to 1,000 ton press brakes in dual and triple drives in 24" or 48" travel

Z1-Z2 + R1-R2 + X1-X2 Axis

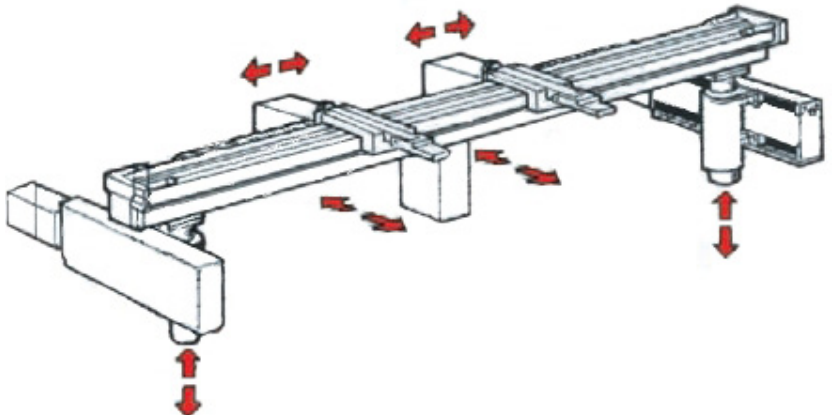

All backgauges are equipped with our precision machined fingers with multiple gauging points for longer part forming

X only

- X axis with 24" travel and heavy duty precision machined fingers with multiple points of gauging.
- Manual R + manual Z full length of gauge bar

X + R

- 8" Programmable R Axis
- Manual Z full length of gauge bar

**X + R + Z1-Z2**

- Fully independent Z1-Z2 programmable actuation across the gauge bar

**X + R + Z1-Z2 + X-Prime**

- One finger includes a programmable adjustment of +, - 3" for tapered bends

**Z1-Z2 + R1-R2 + X1-X2**

- Fully programmable and independent actuation of
Z1-Z2 (left to right)
X1-X2 (front to back)
R1-R2 (up and down)



**Thousands of machines and
Generations of references
across the U.S.**

**Professional, readily
available service just
a phone call away**

**Onsite training and
service technicians
available everywhere**



**UNMATCHED 5 YEAR WARRANTY
based on a 24 hour workday,
7 days a week, 365 days a year**



STANDARD INDUSTRIAL CORP.

CLARKSDALE, MS USA

662.624.2436

WWW.STANDARD-INDUSTRIAL.COM