

AHB

TOOLING & MACHINERY, INC.

COMPLETE METALWORKING SOLUTIONS

(800) 991-4225

www.ahbinc.com

ISO Certified

customerservice@ahbinc.com

MADE IN
U S A

PRESS BRAKES

**A PROVEN
U.S. COMPANY**

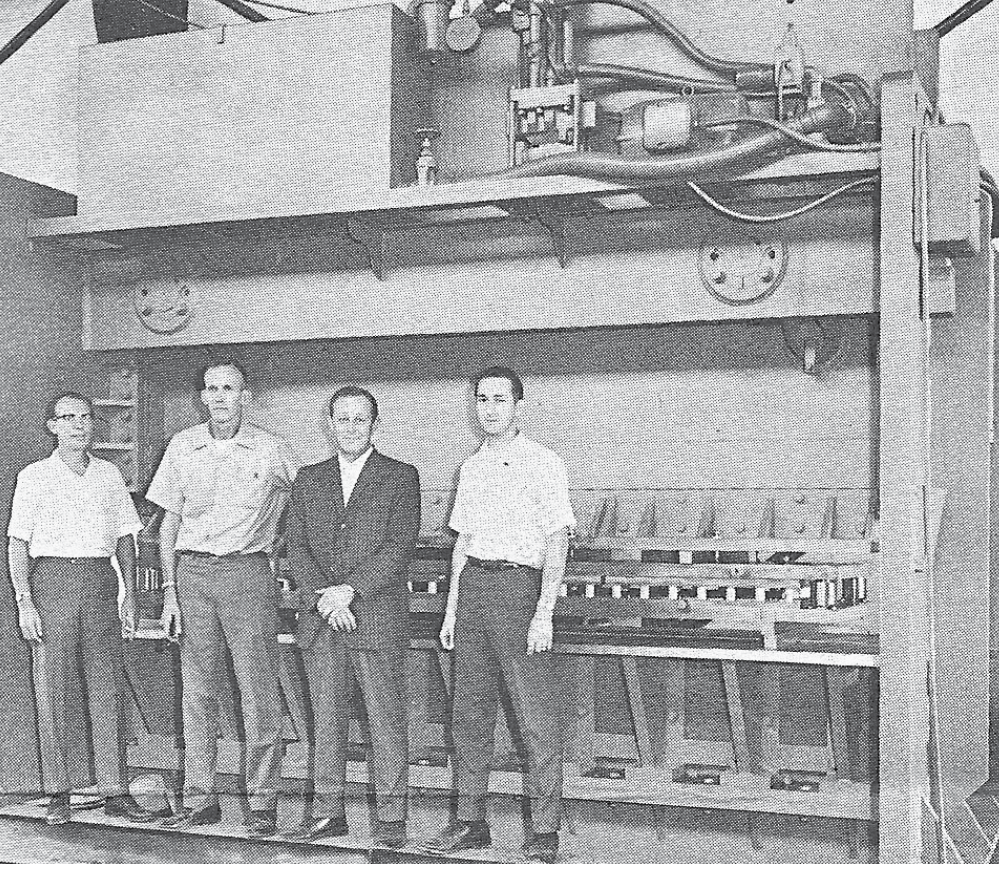

...WITH HUMBLE BEGINNINGS



First C-Frame

First Four Column

First Shear

...AND A VERY BRIGHT FUTURE



STANDARD
INDUSTRIAL CORP

**POWERFUL, PRECISION MACHINES
MADE IN THE USA**

MODEL AB PRESS BRAKES



FULL TONNAGE FULL LENGTH OF BED
 +
 FULL TONNAGE OFF-CENTER LOADING

** All Press Brakes are available optionally with up to 8 axis CNC control including 2D and 3D graphics.



A WARRANTY ONLY A REAL AMERICAN MACHINE CAN OFFER

5 YEAR PARTS/1 YEAR CNC WARRANTY
+
5 YEAR LIMITED ONSITE LABOR WARRANTY



LIFETIME PARTS AVAILABILITY

Every component on this machine is available from your local suppliers, giving you a lifetime of parts from anywhere in the U.S.A.

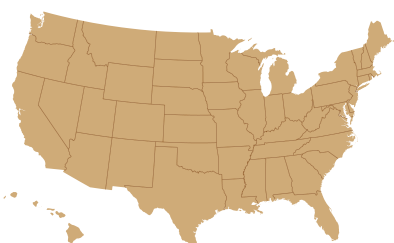

3 POINT GIBBING/GUIDANCE SYSTEM

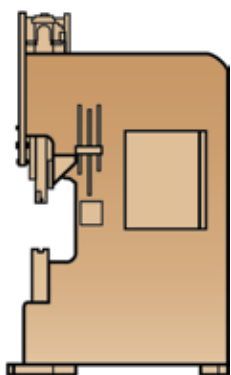

One of the true advantages of the Standard drive system is our ability to provide full tonnage across the bed and ram and not create excessive side loads. This is accomplished because all forces are vertical above the ram centerline and are fully contained within the extremely heavy duty “box” structure. This structure houses the drive system and our impressive 3 point ram guidance/gibbing system.

The front to back forces are controlled with our precision machined set of “ways” combined with extremely heavy duty slides. These ways and guides are located both front and back of the ram and at both ends of the ram. The third set of gibbs is our innovative and very formidable center thrust gibb. This impressive gibbing system is self-aligning and requires no operator action during ram alignment. All three sets of gibbs control the front to back and left to right forces providing the precision $\pm .001$ ” ram repeatability.

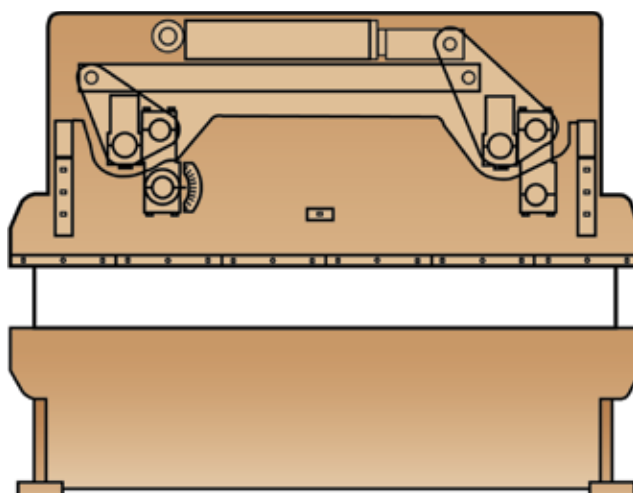
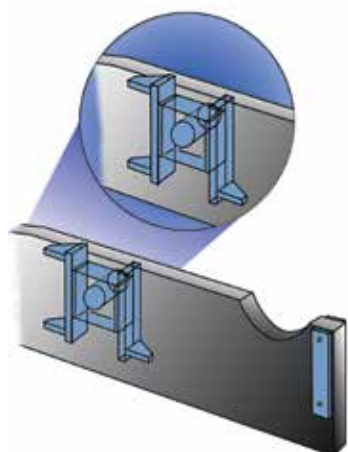

OUR BRAKES ARE SPECIFICALLY DESIGNED FOR THE FOLLOWING APPLICATIONS

FULL LENGTH BENDS where full tonnage across the bed is required for the truest bends

OFF-CENTER LOADING especially when needing substantial tonnage near the ends of the brake

CENTER LOADING when any amount of tonnage is required in the center or anywhere across bed

MULTIPLE DIE SET-UPS across the bed that require the same or varying amounts of tonnage

PUNCHING APPLICATIONS great for punching alone or combined with forming.

SHORT PIECE WORK with some of the fastest ram speeds, your small piece work is done quickly, easily with precision

SINGLE CYLINDER

VS.

DUAL CYLINDER

ONE CYLINDER SYSTEM

The single cylinder hydro-mechanical drive system is the only system that provides full tonnage across the entire length of the bed and ram. Two cylinder drive systems cannot provide full tonnage across the bed because each cylinder only generates just over 1/2 of the machine's overall tonnage.

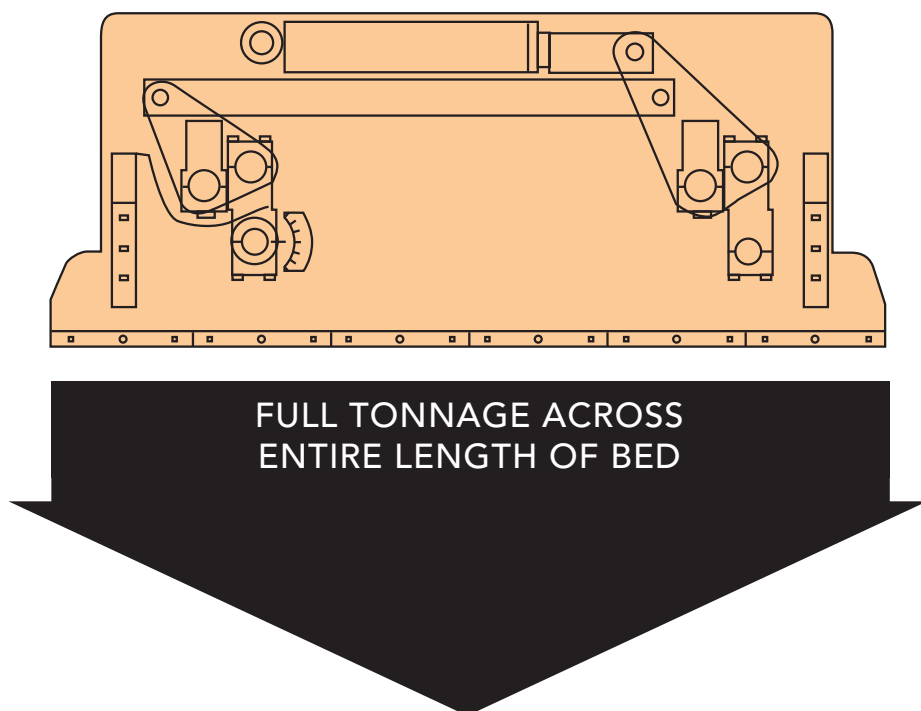

TWO CYLINDER SYSTEM

The further the application gets away from the center of the bed, the less amount of tonnage is generated. For this reason most 2 cylinder machines require crowning units to compensate for this lack of tonnage and/or they open up their v die openings beyond the industry standard widths because their machines do not have the proper tonnage.

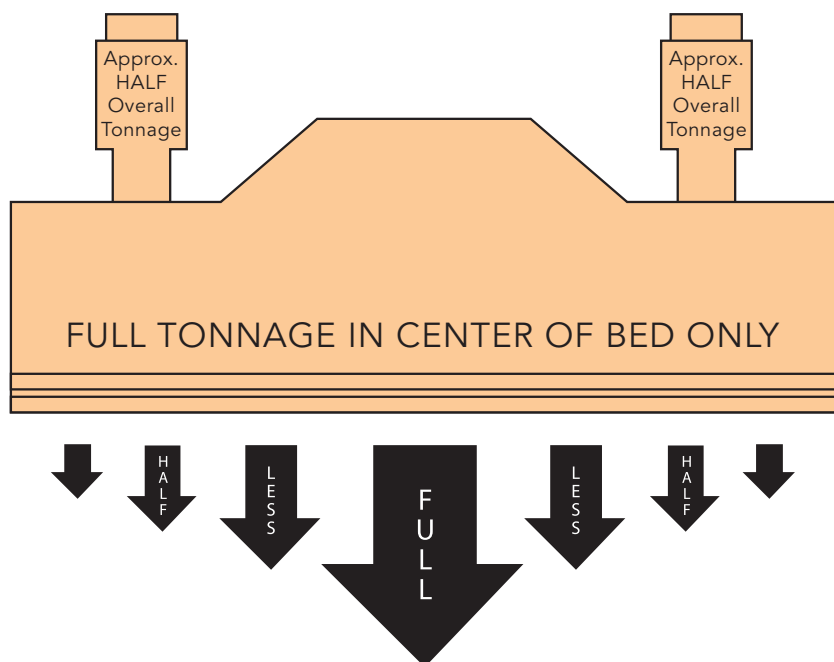

MODELS AND SPECIFICATIONS

STANDARD PRESS BRAKES ARE AVAILABLE IN 100, 150, 200, 250, 325, 400, 500, 600, 700 & 1,000 TON CAPACITIES AND UP TO 24' IN LENGTH.

Model	Forming/ Punching	Bed Length	Bed Hsgs.	Open Ht.	Stroke	Throat Depth	Weight (lbs.)
AB100-6	100/66	6'	4'-5"	13"	6"	6"	12,000
AB100-8	100/66	8'	6'-5"	13"	6"	6"	15,000
AB100-10	100/66	10'	8'-5"	13"	6"	6"	19,000
AB100-12	100/66	12'	10'-5"	13"	6"	6"	21,000
AB100-14	100/66	14'	12'-5"	13"	6"	6"	26,000
AB100-16	100/66	16'	14'-5"	13"	6"	6"	32,000
AB100-20	100/66	20'	18'-5"	13"	6"	6"	50,000
AB150-8	150/100	8'	6'-5"	13"	6"	6"	19,000
AB150-10	150/100	10'	8'-5"	13"	6"	6"	22,000
AB150-12	150/100	12'	10'-5"	13"	6"	6"	25,000
AB150-14	150/100	14'	12'-5"	13"	6"	6"	31,000
AB150-16	150/100	16'	14'-5"	13"	6"	6"	38,000
AB150-20	150/100	20'	18'-5"	13"	6"	6"	72,000



AB100-6



AB200-12

Model	Forming/ Punching	Bed Length	Bed Hsgs.	Open Ht.	Stroke	Throat Depth	Weight (lbs.)
AB200-12	200/135	12'	10'-5"	14"	8"	10"	28,000
AB200-14	200/135	14'	12'-5"	14"	8"	10"	45,000
AB200-16	200/135	16'	14'-5"	14"	8"	10"	50,000
AB200-20	200/135	20'	18'-5"	14"	8"	10"	85,000

Model	Forming/ Punching	Bed Length	Bed Hsgs.	Open Ht.	Stroke	Throat Depth	Weight (lbs.)
AB250-12	250/165	12'	10'-5"	16"	8"	10"	38,000
AB250-14	250/165	14'	12'-5"	16"	8"	10"	50,000
AB250-16	250/165	16'	14'-5"	16"	8"	10"	56,000
AB250-20	250/165	20'	**16'-5"	16"	8"	10"	85,000



AB250-12

SIMPLE MATH

Standard Industrial 5 Year Parts Warranty is based on a 24 Hour workday which equals:

43,800 HOURS OF WARRANTY

Compared to a typical 1 year warranty we exceed them by:

35,040 HOURS

Compared to a 2 year parts warranty based on an 8 hour work day we exceed them by:

37,960 HOURS

NO OTHER PRESS BRAKE CAN MATCH OUR DEPENDABILITY OR OUR WARRANTY



AB325-12



AB325-14

Model	Forming/ Punching	Bed Length	Bed Hsgs.	Open Ht.	Stroke	Throat Depth	Weight (lbs.)
AB325-12	325/215	12'	10'-5"	16"	8"	10"	46,000
AB325-12	325/215	14'	12'-5"	16"	8"	10"	60,000
AB325-12	325/215	16'	14'-5"	16"	8"	10"	66,000
AB325-20	325/215	20'	**16'-5"	16"	8"	10"	95,000

COMPLETE PARTS BILLS OF MATERIALS IN MANUAL WITH ORIGINAL MANUFACTURER'S PART NUMBER SO YOU WILL **ALWAYS** BE ABLE TO FIND PARTS

AB400-14



Model	Forming/ Punching	Bed Length	Bed Hsgs.	Open Ht.	Stroke	Throat Depth	Weight (lbs.)
AB400-12	400/265	12'	10'-5"	20"	10"	10"	58,000
AB400-14	400/265	14'	12'-5"	20"	10"	10"	67,000
AB400-16	400/265	16'	14'-5"	20"	10"	10"	80,000
AB400-20	400/265	20'	**16'-5"	20"	10"	10"	100,000

Model	Forming/ Punching	Bed Length	Bed Hsgs.	Open Ht.	Stroke	Throat Depth	Weight (lbs.)
AB500-12	500/330	12'	10'-5"	20"	10"	10"	70,000
AB500-14	500/330	14'	12'-5"	20"	10"	10"	80,000
AB500-16	500/330	16'	14'-5"	20"	10"	10"	87,000
AB500-20	500/330	20'	**16'-5"	20"	10"	10"	100,000



AB500-12

Counterbalance valves are standard on all brakes to provide up to 2/3 punching tonnage of overall tonnage

5 YEAR LIMITED LABOR WARRANTY

OUR STANDARD 5 YEAR LIMITED LABOR WARRANTY GUARANTEES IF ANY PROBLEM CANNOT BE IDENTIFIED VIA TELEPHONE AND TROUBLESHOOTING HAS BEEN EXHAUSTED, **WE WILL SUPPLY A TECHNICIAN AT YOUR FACILITY AT NO CHARGE FOR 5 YEARS.**

SIMPLY THE BEST WARRANTY AVAILABLE

AB600-14



AB700-14



Model	Forming/ Punching	Bed Length	Bet Hsgs.	Open Ht.	Stroke	Throat Depth	Weight (lbs.)
AB600-12	600/400	12'	10'-5"	22"	10"	10"	87,000
AB600-14	600/400	14'	12'-5"	22"	10"	10"	97,000
AB600-16	600/400	16'	14'-5"	22"	10"	10"	108,000
AB600-20	600/400	20'	**16'-5"	22"	10"	10"	150,000

Model	Forming/ Punching	Bed Length	Bet Hsgs.	Open Ht.	Stroke	Throat Depth	Weight (lbs.)
AB700-14	700/465	14'	12'-5"	24"	12"	10"	112,000
AB700-16	700/465	16'	14'-5"	24"	12"	10"	135,000
AB700-20	700/465	20'	**16'-5"	24"	12"	10"	180,000
AB1000-14	1000/660	14'	12'-5"	24"	12"	10"	160,000
AB1000-16	1000/660	16'	14'-5"	24"	12"	10"	170,000
AB1000-20	1000/660	20'	**16'-5"	24"	12"	10"	195,000

All Standard press brakes are designed meet O.S.H.A and ANSI B11.3 standards and comes complete with J.I.C. type listed electrical components.

STANDARD FEATURES

5 YEAR PARTS + 5 YEAR LIMITED LABOR + 1 YEAR CNC/PLC WARRANTY

Every Standard machine is equipped with our unmatched 5 year parts warranty. This warranty includes a 5 year limited onsite labor warranty and a 1 year CNC/PLC Warranty. Unlimited lifetime telephone support is included at no charge. If during the first 5 years you have an unresolved issue and telephone troubleshooting has been fully exhausted we will provide onsite labor to take care of the problem. This warranty is based on 3 shifts a day and 24 hour days. Every machine is also available with our optional 7 Year Extended Warranty that extends the parts warranty by 2 years.

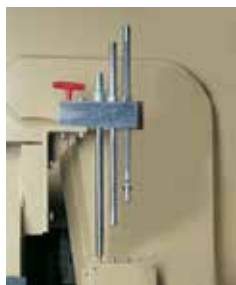

MECHANICAL IN-LINE DEPTH STOP

The in-line depth stop is equipped on every base Standard press brake. Simple, precise mechanical limit switches to control open height, speed change point and a micrometer adjustment to achieve precision angles. This insures NO down time due to computer failure. Just decades of steady, reliable service. *Not available with some CNC controls.*



EXTREMELY HEAVY-DUTY BED WITH AMERICAN STYLE DIE GROOVE

Incredibly heavy duty lower beams are essential to any well made press brake. Every Standard brake is equipped with a groove in the center of the bed to hold your American style tooling plus Standard prides itself on having the least amount of deflection of any press brake on the market. Less Deflection = Longer Tool & Machine Life



HAND/FOOT SAFETY SEQUENCE WITH FOOTSWITCH

2 palm button pedestal control with 3 position footswitch allowing operator to use palm buttons during fast approach and the footswitch during slow pressing speed.

HYDRAULIC PRESSURE TONNAGE CONTROL

Tonnage can be pre-set as required with a simple tonnage control system and gauge.

24" WORK SUPPORT ARMS



(2) heavy duty 24" work support arms are standard on brakes up to 14'. All 16' and longer brakes come with (3) arms. Each arm bolts up to front of press brake bed or can slide left to right across front edge of bed with optional t-slot.

MANIFOLD CENTRALIZED LUBRICATION SYSTEM

Each press brake is equipped with our super efficient manifold lube system that brings all lubrication points to one easily accessible area (except optional backgauge screws). Maintenance is reduced and machine longevity is increased with this simple time saving feature.

AMERICAN STYLE HEAVY DUTY RAM CLAMPING



Extremely heavy duty, spring loaded die clamps for easy, fast die changes. Accepts all American style standard and precision tooling. All press brakes can be ordered with Wila (or equiv.) style quick change powered ram clamping systems and European clamping systems in lieu of manual system.

SIMPLE AND PRECISE RAM TO BED LEVEL ADJUSTMENT



Primarily for realignment of dies and off-center loading applications. Change level as needed in seconds.

Convenient ram level indicator showing distance from zero point (ram level). Very visible and easy to read.
NOTE: Power tilting systems available



OPTIONAL FEATURES

7 YEAR PARTS WARRANTY

Only available from Standard Industrial Corp. is our unmatched Extended Warranty that substantially lengthens the existing 5 year parts warranty and still provides our standard 5 year limited onsite labor warranty.

This package includes:

- A 7 year parts warranty in lieu of standard 5 year parts warranty
- A 1 year PLC and CNC warranty
- A 5 year onsite limited labor warranty

In the event of a problem the customer will be required to help troubleshoot over the phone. If the problem cannot be diagnosed and troubleshooting has been exhausted, Standard will send in a technician at no charge to resolve the situation during the entire 5 year warranty.

PRESS BRAKE CONTROLS

Additional Pedestal and/or Footswitch Control—One pedestal and Footswitch control are standard on all press brakes. This option makes it safe for up to (2) operators to run the machine at the same time.

Auto Return of Ram—Normal operation allows ram to return after pedestal/footswitch is released. This option makes the ram return automatically once cycle is complete even if footswitch is still depressed.

Decompression System—Time-delay system required for bottoming applications

Low Speed Retract—Slows the ram return speed considerably for large material handling. Typically for press brakes 400 tons and above with large flange work.

Power Ram Tilt—A manual ram tilt adjustment is standard on all press brakes and is sufficient for most customers, it is quick and easy and allows up to $\pm 1/8$ " of the centerline. Optionally we can offer a powered system that tilts the ram $\pm 3/8$ " of the centerline and is changed instantly at the push of a button. Typically for larger press brakes.

Four Position In-Line Depth Stop—Simple NON-COMPUTERIZED mechanical ram control that allows you to pre-set up to 4 different depths/angles that are selected from your pedestal via a selector switch.

4 Position selector switch located on 2 hand control pedestal.

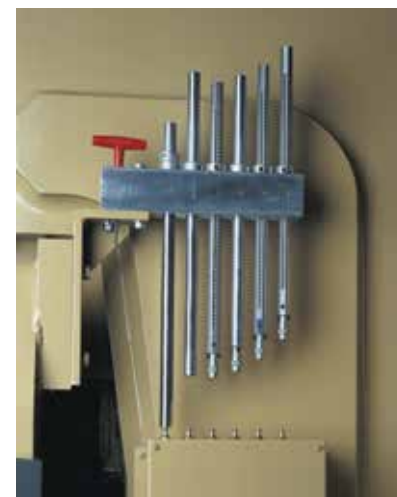

SAFETY FEATURES AND CONTROLS

LIGHT CURTAIN SAFETY BARRIER

Infra-red light curtain across the front of press brake coupled with physical side barriers protects the operator. Tapeswitch curtains are available as well as customer preferred brands per special quote.

Made in the U.S.A.



LASER GUARDING SYSTEMS

State of the art laser systems wrap around punch to allow operator closer proximity to pinch-point and still be OSHA approved. Not recommended for punching/bottoming applications.

INTERLOCKING PHYSICAL BARRIERS/CAGES

Heavy duty, enclosed physical barriers do not allow access to rear brake. Interlocking gates shut machine down when opened.

COMPLIANCE OPTIONS

U.L. Listing, CSA and ZED compliance are available optionally. All parts on the machines are U.L. listed. Contact factory for other compliance options.

HIGH SPEED HYDRAULICS PACKAGES

All press brakes are available with high speed packages to increase productivity. Each system is equipped with oil cooler to maintain proper temperature and increase system longevity. Contact the factory for typical systems or customized systems per your special needs.

AUTOMATIC LUBRICATION SYSTEM

Air operated, timed system that automatically brings grease to all lubrication points (except backgauge screws). A great option for multiple shift operations. Manifold centralized lubrication system is standard on all brakes.



OPTIONAL FEATURES

SUPPORT ARMS, QUICK-RELEASE SYSTEMS AND SHEET FOLLOWERS

T-Slot across Front Edge of Bed—5/8" t-slot across front edge of bed to allow work support arms to slide left to right across full length.

Gravity Stops for T-Slot Support Arms—Precision machined stops for t-slots that allow work piece to slide over the top of slide but not backward.

24", 36" or 48" Heavy Duty T-slot Support Arms—Work support, bolt-down, arms with precision machined t-slotted bars to place gravity or other stops in for front gauging. Available with embedded scale. NOTE: Each brake comes standard with (2) non-t-slotted work support arms.

QUICK-CHANGE LINEAR WORK SUPPORT SYSTEM

Heavy duty, quick-release style work support arms equipped with smooth transition rollers and precision machined ways. Multiple vertical and horizontal adjustments allow precision control. This system allows the operator to quickly move arms left/right/up/down for rapid set-up. Arms are available in 24" and 36" lengths.



CNC SHEET ASSIST SUPPORT SYSTEMS

Controlled by a CNC controller, these heavy duty material assists rise and lower with the ram movement. Portable and precise, the circular arc of the arms follows the part being formed. This system not only provides your operator with a level of assistance but the quality of bend will benefit from the following action.

NON-CNC SHEET ASSIST/FOLLOWERS

Durable and more economical than the CNC versions, these portable sheet followers hold up to 425 lbs and can be moved quickly and easily. Fully actuated by the press ram movement, this system requires no operator interaction. ***Made in the U.S.A.***

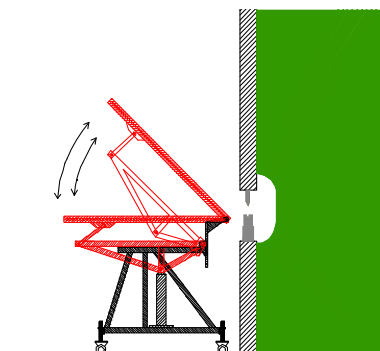

REMOVABLE AND PERMANENT BED AND RAM EXTENSIONS

5" x 5" Removable Angle Flanges— Utilize your machine both as a press brake **and** as a press by extending the width of your bed by 10"x10' long for wider press die configurations. With Standard's ability to provide full tonnage across the bed you can use the machine in straight side and other press type applications.

Machining Only for Removable Flanges— When unsure what flange size is needed, you can choose to only get the bed and ram machined at time of construction so brake is prepared for your future flanges.

Permanent Bed and/or Ram Flanges— Choose from a wide variety of permanent bed and ram flanges to economically use a press brake for pressing applications.



RAM AND BED MODIFICATIONS—CUSTOMIZATION TO FIT YOUR NEEDS



Extra Open Height— Increases distance from bottom of ram to top of bed — Does not automatically increase stroke.

Extra Stroke Length— Increases distance of down ram travel — Does not automatically increase open height.

Extra Throat Depth— Increases distance from centerline of bed to gap/throat of end of frame.

Horn Extensions— Lengthens bed and ram length without lengthening distance between housings.



OPTIONAL FEATURES

WILA TOOLING, CROWNING, CLAMPING AND ACCESSORIES

CROWNING Because Standard has the rare ability to provide full tonnage the entire length of the bed and because our machines have the least amount of deflection of any machine on the market, crowning is very rarely a necessity. Certain applications such as multiple die sets being utilized in one stroke or a larger brake forming a wide range of material, a crowning unit may be desirable.

All of our press brakes are available with Wila crowning units.

- Manual & Hand cranks with readers for precision adjustment in seconds
- CNC crowning units can be programmed to adjust for every program
- Optional clamps for 4 way dies
- Adjustment screws every 8" for variances in bed and fine adjustment
- Built in clamping bars which automatically center and align single v dies



AMERICAN AND NEW STANDARD PRECISION TOOLING

- Precision ground to $\pm .0004$ " & hardened at wear points to Rockwell 60c
- Punches and dies available for air and bottom bending
- Segmented to allow for any length bending
- American precision tooling can fit any American style tool holder
- The essence of the Wila top tools is the Safety-Click[®] mechanism. This enables the vertical changeover of tool segments by simply clicking them in and out of the holder vertically. This gives you substantial time savings as well as a safety factor you will not find with any other tooling system.



PUSH BUTTON QUICK-CHANGE TOOLING SYSTEMS FOR THE RAM AND BED



- Safety-Click button to snap tools in and out vertically in seconds
- Punches automatically clamp, seat & align with ONE button
- Both tooling and clamping are precision ground to $\pm .0004$ "
- Available with hydraulic and mechanical clamping for 5 to 10 times faster set-up than conventional clamping systems.
- Clamping systems available for retro-fit in all Standard brakes
- Available manually or with a hydraulic power pack

TOOLING

Standard offers all designs and styles of tooling including precision, non-precision American style, European, Four way dies, hemming, offset, channel, curling, rocker, etc. We also provide custom made tooling for press brakes and press applications. No tooling comes standard on the press brake. Contact us today for all your tooling requirements. Made in the U.S.A.

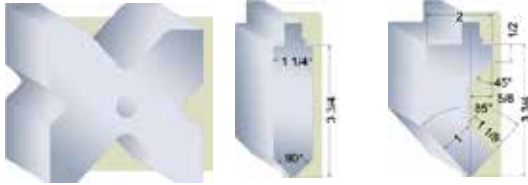

Single V & Four Way Die Sets

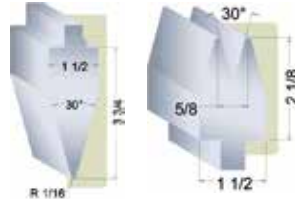

Acute Die Sets

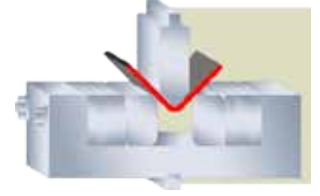

Adjustable Die Sets

CNC CONTROLS AND GAUGING SYSTEMS

Standard Industrial offers a wide variety of CNC gauging from the most basic single line display, user-friendly controls to state of the art 2D and 3D modeling and all systems in between. No backgauge or CNC control comes standard with a press brake. Please refer to our separate CNC Controls and Gauging catalog for a complete line of our systems.

CNC gauging available with:

--Y Only (no X axis)
--Y/X/R/Z1-Z2
--Y/Z1-Z2/X1-X2/R1-R2

--Y/X manual R/Z
--Y/R/Z1-Z2/X-Prime
--CNC Crowning + Peripherals

--Y/X/R manual Z
--Y/X/Z1-Z2/X1-X2

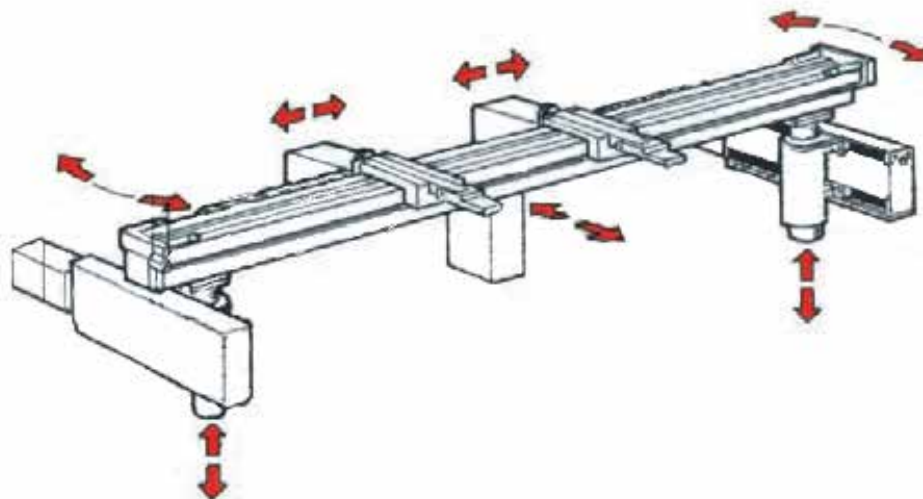



**STANDARD INDUSTRIAL CORPORATION
CLARKSDALE, MS
UNITED STATES OF AMERICA**

800-991-4225

www.standard-industrial.com

**ALSO AVAILABLE FROM STANDARD INDUSTRIAL
GUILLOTINE SHEARS FROM 10 GAUGE UP TO 1.5" CAPACITY**



C-FRAME, 4 COLUMN & STRAIGHT SIDE PRESSES FROM 60 up to 1,000 TONS

