

KINECHEKS®

SKIPCHEK®

SKIPCHEK

 SLIMLINE KINECHEKS can be provided with a SKIPCHEK feature in 1/2 inch, 1 inch, 2 inch and 3 inch stroke models. The fast feed (skip) interval reduces machining times when it is desired to line drill tubular sections, clevis parts etc.

The skip feature is accomplished by adding a “by-pass” flow passage to the cylinder, thus permitting the SKIPCHEK to advance with minimal resistance over the duration of the passage. Each unit is tailor made to the user’s specifications. Since Deschner KINECHEKS avoid the complexity of added moving parts and seals, the user will benefit by receiving the long service life associated with all Kinecheks.

A design sheet is provided on page 14 to assist in establishing the information necessary for us to manufacture the SKIPCHEK. Part Numbers will be assigned after your requirements are finalized.

The skip function is usually furnished in either of two styles as follows:

STYLE S (C.F. + F.F. + C.F.):

Controlled feed followed by a fast forward and then a return to a controlled feed for the balance of the stroke. This style is usually utilized for drilling tubing, clevis joints or any application requiring 2 holes in line with a space between the holes.

STYLE N (C.F. + F.F.):

Controlled feed followed by a fast forward for the balance of the stroke. This style has been used for combined drilling and tapping or on special applications.

Note: C.F. means controlled feed and F.F. means fast forward (skip).

1 Model No. of Kinecheks Skipchek * Designate Style “S” or “N” **C.F. and F.F. Requirement (See Design Information)	2 Stroke	3 Minimum Force That Will Operate Plunger Full Stroke	4 Plunger Return Spring Force	5 Time Req'd for Plunger to Return Outward if Released Suddenly	6 Load That Will Push Plunger 1 in. Per Sec. at Fastest Adjustment	7 Load That Will Push Plunger 4 in. Per Sec. at Fastest Adjustment	8 C.F. at Slowest Adjustment		
							1000 lb. Load	500 lb. Load	100 lb. Load
1002_*-31-1/2(___ C.F./___ F.F.)**	1/2 in.			.031 sec.					
1002_*-31-1 (___ C.F./___ F.F.)**	1 in.	5 lbs.	4 lbs.	.063 sec.	11 lbs.	33 lbs.	.067	.029	.0033
1002_*-31-2 (___ C.F./___ F.F.)**	2 in.			.106 sec.			in./sec.	in./sec.	in./sec.
1002_*-31-3 (___ C.F./___ F.F.)**	3 in.			.235 sec.					

Capacity: 1200 lbs. Maximum – Including Impact When Load Strikes Plunger

135° F Maximum Continuous Operating Temperature

Stroke	Weight	A	B	C
1/2 in.	11.5 oz.	6.33	.687	4.28
1 in.	12.5 oz.	7.83	1.187	5.28
2 in.	16.5 oz.	10.87	2.187	7.31
3 in.	19.2 oz.	13.87	3.187	9.31

Note: SKIPCHEKS may be used with Model A10031 mounting block. See page 6 for mounting block dimensions.

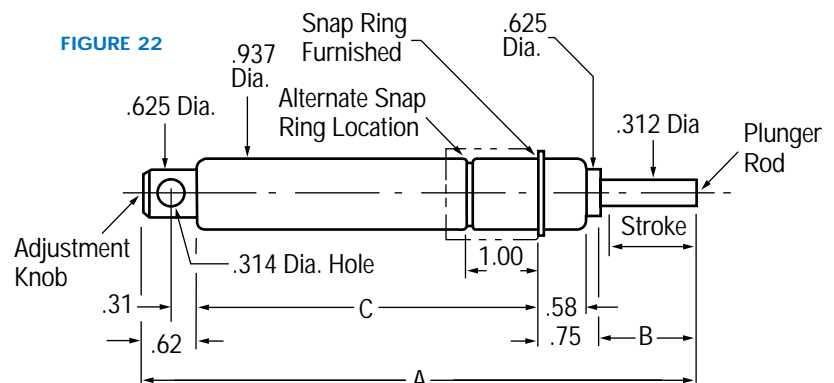

DESIGN INFORMATION

SKIPCHEK SPECIFICATIONS

1. 1st C.F. _____ +.062/-0.000 in. (_____ +1.6/-0.0 mm.)
2. F.F. _____ +.000/-0.062 in. (_____ +0.0/-1.6 mm.)
3. Total SKIPCHEK stroke _____ in. _____ (mm.) Nominal
4. Drill thrust _____ lbs. (_____ kg.)
SKIPCHEK will be tested at 150 lbs (68 kg.) if no thrust load is specified.

REFERENCE DATA

5. Round tube: Yes _____ No _____
If yes: O.D. _____ in. (_____ mm.)
wall thickness _____ in. (_____ mm.)
6. If work material is not round tubing:
Specify: Thickness of 1st section _____ in. (_____ mm.)
Distance between sections _____ in. (_____ mm.)
Thickness of 2nd section _____ in. (_____ mm.)
7. Drill Dia. _____ in. (_____ mm.)
Point angle _____ degrees (included)
8. C.F. Feed Rate _____ in./min. (_____ mm./min) (if known)

Specification items 1 thru 3 are mandatory information we must have. Item 4 will not have an appreciable effect unless thrust loads exceed 350 lbs. Items 5 thru 8 are for the users consideration to be sure all aspects have been considered including part curvature, drill point height etc. The transition tolerances shown on the design sheet are necessary and must also be allowed for when establishing specifications.

Note: C.F. means controlled feed. F.F. means fast forward (skip).

Note: Drill point height, transition tolerances and part curvature (if any) should be considered when establishing specifications. Completion of the reference data will assist in establishing 1st C.F. and F.F. specifications. (Transition tolerances increase C.F. or decrease F.F. as shown.)

