

selffeederTM global

Highly Accurate and Durable Drilling Units



GSA type



Small and light weight unit with 0.25kW motor.
Steady small hole drilling can be done.

Collet chuck spindle nose

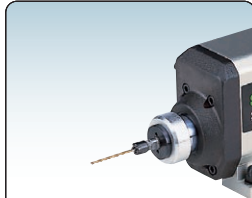

Refer to page 9 for details

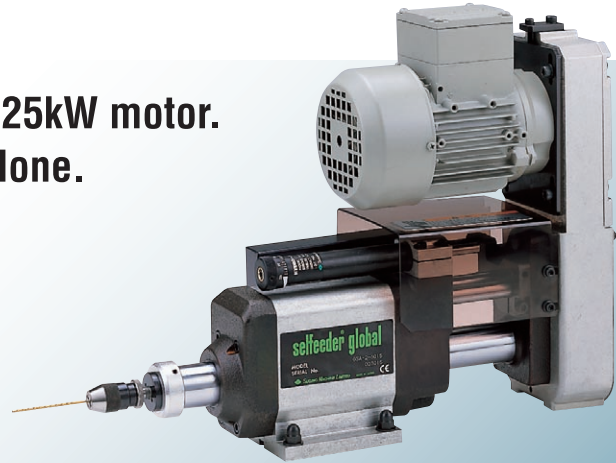

Capacity

Operating air pressure: 0.5 MPa

Specs. Model	Spindle speed (no load)		Chuck Capacity	Max. drill size			Stroke		Motor		Thrust N	Air Consumption L/Stroke	Weight kg
	50Hz	60Hz		Aluminium	Cast Iron	Carbon Steel	Max.	Regulated cutting	Output kW	No. of Pole P			
	min ⁻¹												
GSA-2-3100	10,000	12,000	3 (Keyless Drill Chuck)	2.5	1	1	80	0~30	0.25	2	840	4	17
GSA-2-3085	8,500	10,000		3	1	1							
GSA-2-3060	6,000	7,200		4	1.5	1.5							
GSA-2-6045	4,500	5,400	6.5	5.5	2	2							
GSA-2-6030	3,000	3,600		6.5	3	3							
GSA-2-6020	2,000	2,400		7.5	4.5	4.5							
GSA-2-6015	1,500	1,800		8	6	6							
GSA-2-6011	1,100	1,300		9	8	6.5							

- Note 1. Model selection should be done from the above chart, based on workpiece specifications, material hardness, diameter of hole and cutting speed.
- The drilling capacity shown above is for a depth equivalent to the drill diameter times two.
- The RB-2430 is installed as a standard type Hydro-Speed Regulator. Specify an optional Hydro-Speed Regulator as necessary. Refer to page 6 and 7 for details.
- When ordering, specify the voltage and frequency of the motor.
- The materials quoted are equivalent to following JIS code, Aluminium : ADC, Cast Iron : FC200, Carbon Steel : S45C
- Please use the collet chuck spindle noses when the hardness of the cemented carbide drill and tool shank is higher than that of a general high speed steels.

Dimensions (mm)

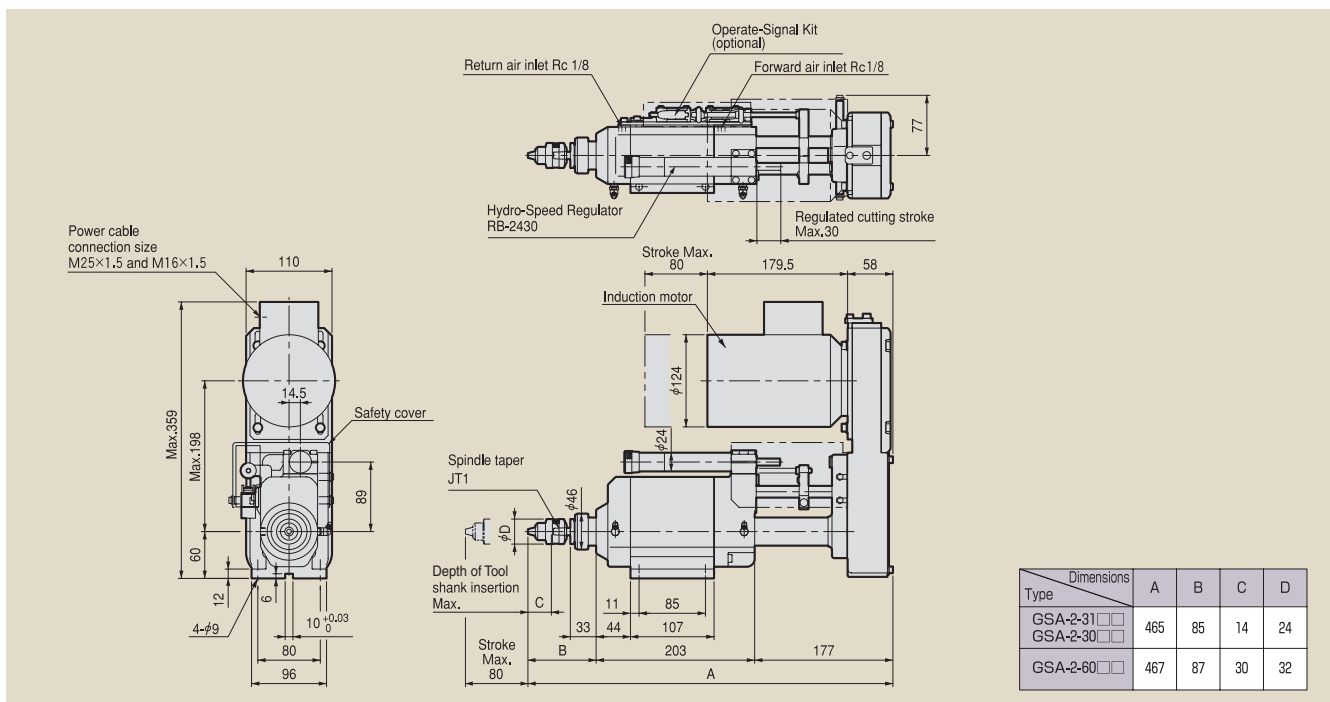

GSB type



Full line-up from high speed to low speed.
It is suitable for machining with special tools such as carbide drill, reamer and mill.

Adjustable spindle nose

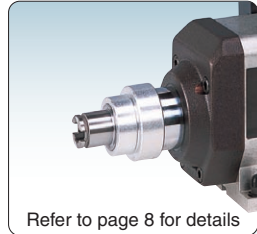

Refer to page 8 for details



Capacity

Operating air pressure: 0.5 MPa

Specs. Model	Spindle speed (no load)		Chuck Capacity mm	Max. drill size			Stroke		Motor		Thrust N	Air Consumption L/Stroke	Weight kg
	50Hz	60Hz		Aluminium	Cast Iron	Carbon Steel	Max.	Regulated cutting	Output kW	No. of Pole P			
	min ⁻¹												
GSB-2-6075(L)	7,500	9,000	6.5	3	1.5	1	100 (150)	0~30	0.55	2	1,225	5 (8)	27.5 (29)
GSB-2-6060(L)	6,000	7,200		4	1.5	1.5							
GSB-2-6046(L)	4,600	5,500		5.5	2	2							
GSB-2-1330(L)	3,000	3,600		8	3	3							
GSB-2-1320(L)	2,000	2,400		9.5	4.5	4.5							
GSB-2-1315(L)	1,500	1,800		10.5	6	6							
GSB-2-1312(L)	1,200	1,400	12	8	8	0.37		4	27 (28.5)				
GSB-4-1337(L)	3,700	4,500	6.5	2.5	2.5								
GSB-4-1330(L)	3,000	3,600	7.5	3	3								
GSB-4-1323(L)	2,300	2,700	8	4	4								
GSB-4-1315(L)	1,500	1,800	9	6	6								
GSB-4-1310(L)	1,000	1,200	10.5	9	7.5								
GSB-4-1307(L)	750	900	12.5	10	8.5								
GSB-4-1306(L)	600	700	13	11	9.5								

- Note 1. Numbers in bracket are for the long stroke models.
 2. Model selection should be done from the above chart, based on workpiece specifications, material hardness, diameter of hole and cutting speed.
 3. The drilling capacity shown above is for a depth equivalent to the drill diameter times two.
 4. The RB-2430 is installed as a standard type Hydro-Speed Regulator. Specify an optional Hydro-Speed Regulator as necessary. Refer to page 6 and 7 for details.
 5. When ordering, specify the voltage and frequency of the motor.
 6. The materials quoted are equivalent to following JIS code. Aluminium : ADC, Cast iron : FC200, Carbon Steel : S45C
 7. The belt pulley detaching tool is an option.
 8. Please use the collet chuck spindle noses when the hardness of the cemented carbide drill and tool shank is higher than that of a general high speed steels.

Dimensions (mm)

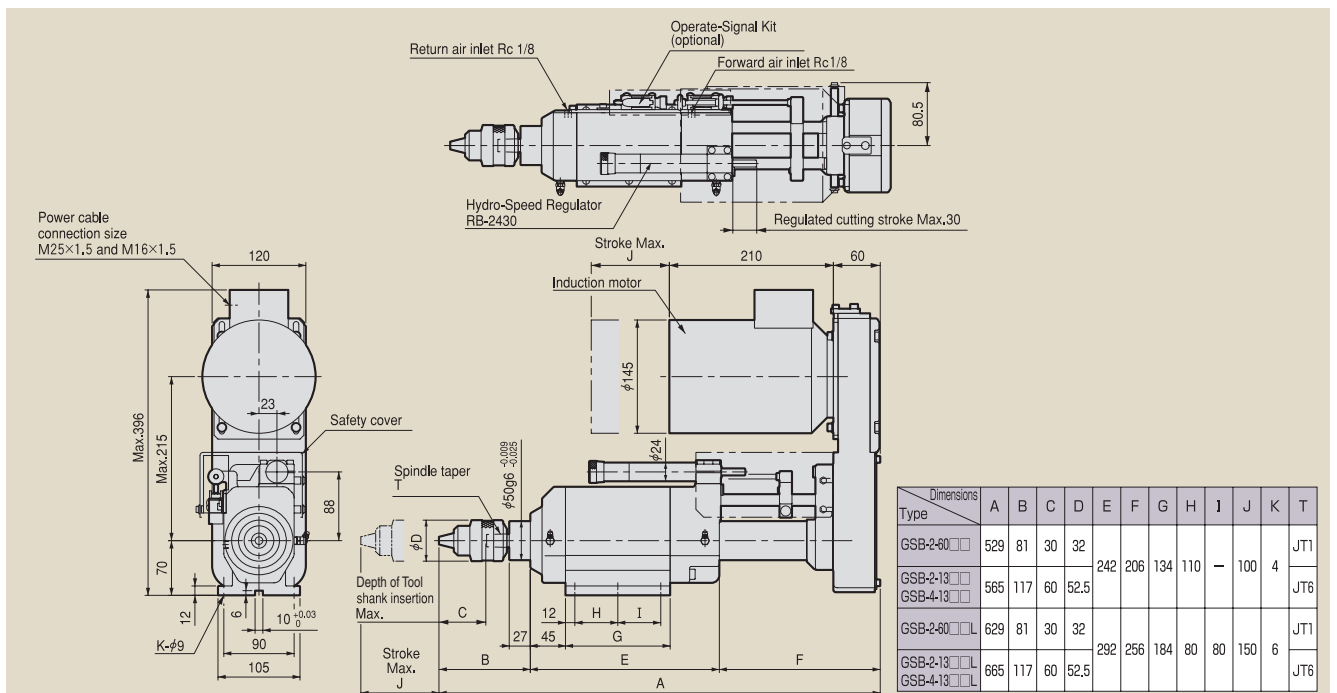

GSC type



Heavy duty unit with high torque and high thrust.
High efficiency production can be done with multi spindle drill head.

Adjustable spindle nose

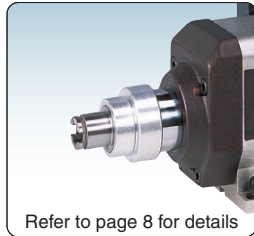

Refer to page 8 for details



Capacity

Operating air pressure: 0.5 MPa

Model	Spindle speed (no load)		Chuck Capacity	Max. drill size			Stroke		Motor		Thrust	Air Consumption	Weight
	50Hz	60Hz		Aluminium	Cast Iron	Carbon Steel	Max.	Regulated cutting	Output	No. of Pole			
	min ⁻¹												
GSC-2-1361(L)	6,100	7,300	13	4	1.5	1.5	100 (200)	0~40	1.1	2	2,260	9 (16)	53 (60)
GSC-2-1342(L)	4,200	5,000		6	2	2							
GSC-2-1330(L)	3,000	3,600		8.5	3	3							
GSC-2-1321(L)	2,100	2,600		12	4.5	4.5							
GSC-2-1315(L)	1,500	1,800		14	6	6							
GSC-4-1330(L)	3,000	3,600		8.5	3	3			0.75	4			52.5 (59.5)
GSC-4-1321(L)	2,100	2,500		10.5	4.5	4.5							
GSC-4-1315(L)	1,500	1,800		12.5	6	6							
GSC-4-1311(L)	1,100	1,300		14	8.5	8.5							
GSC-4-1307(L)	750	900		16	12	11.5							

- Note 1. Numbers in bracket are for the long stroke models.
 2. Model selection should be done from the above chart, based on workpiece specifications, material hardness, diameter of hole and cutting speed.
 3. The drilling capacity shown above is for a depth equivalent to the drill diameter times two.
 4. The RB-3140 is installed as a standard type Hydro-Speed Regulator. Specify an optional Hydro-Speed Regulator as necessary. Refer to page 6 and 7 for details.
 5. When ordering, specify the voltage and frequency of the motor.
 6. The materials quoted are equivalent to following JIS code. Aluminium : ADC. Cast Iron : FC200. Carbon Steel : S45C
 7. The belt pulley detaching tool is an option.
 8. Please use the collet chuck spindle noses when the hardness of the cemented carbide drill and tool shank is higher than that of a general high speed steels.

Dimensions (mm)

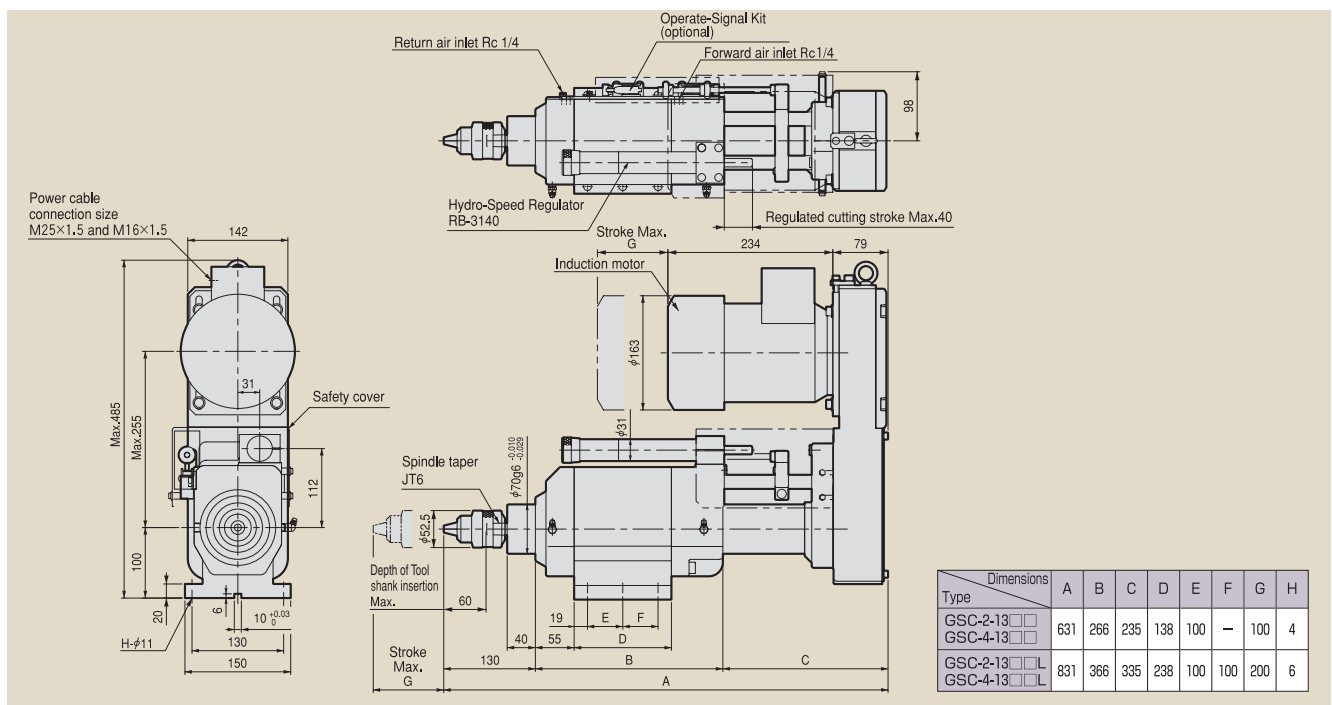

Air Pressure Control Circuits

selffeeder global is equipped with a built-in air cylinder for the control of forward and return movements.

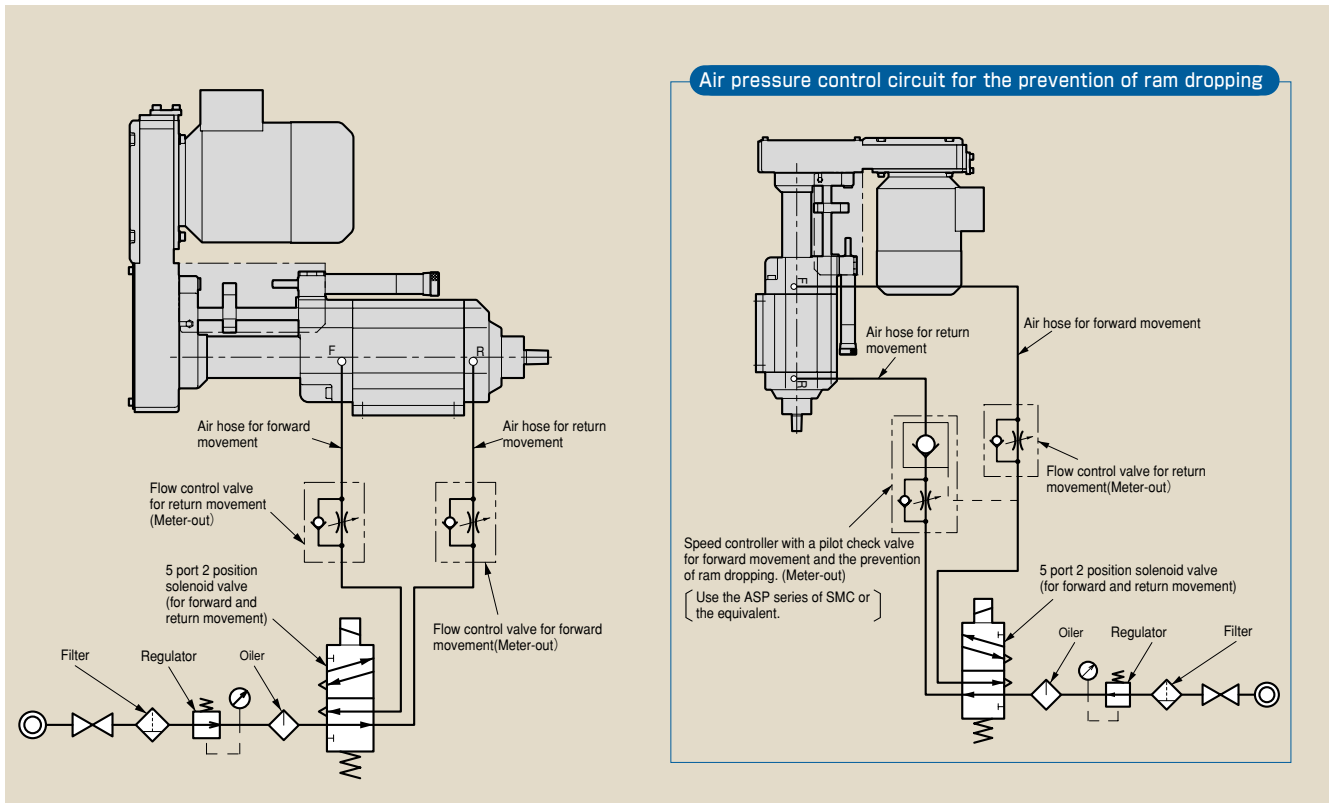

- Note 1. selffeeder global requires the filtered air with 0.4 - 0.6 MPa.
 2. Pneumatic equipments to the air inlets are provided by customer.
 3. selffeeder global has same dimension of air cylinder for forward and return movement. Be sure to use the meter-out flow control valve.

Operate-Signal Kits

Operate-Signal Kit is the detector kit for the Max. drill depth and return position of selffeeder global. Utilize it for the signal of the synchronized operation of selffeeder global with the peripheral devices.

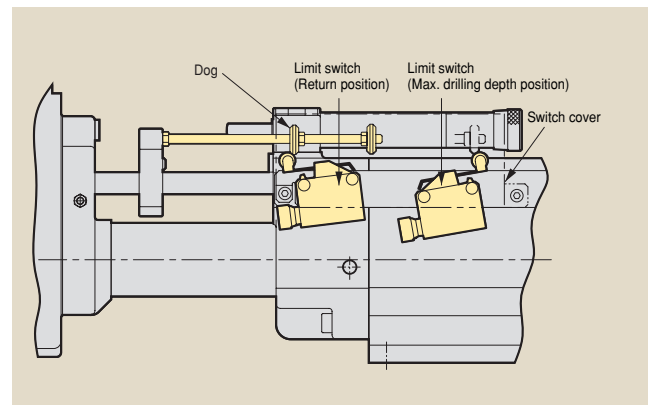
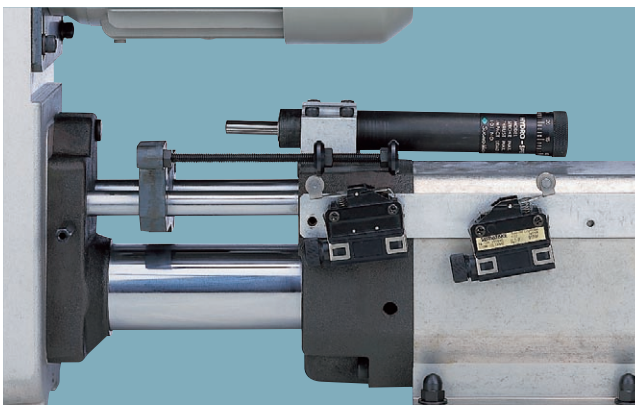

Note : Limit switch is SL1-P of Yamatake.

Models of Operate-Signal Kits and Specifications

Applicable Operate-Signal Kit changes according to the model of selffeeder global.

Model No.	Types of Detection	Applicable selffeeder global
OSK-80G-WM	Check of Max.Drilling depth & Return position	GSA type
OSK-100G-WMN		GSB type
OSK-150G-WMN		GSB-L type
OSK-100GC-WMN		GSC type
OSK-200G-WMN		GSC-L type

Hydro Speed Regulators

The hydro speed regulator is a hydraulic feed speed control unit to control the feed speed of selfeeder global freely. The regulator is available in two different types of the spring return type (RB type) and the air return type (R-A type) to suit the control patterns.

RBtype [Spring return type]

In the hydro speed regulator RB type, the piston rod is automatically returned to its original position by the built-in spring when the piston rod is no longer loaded.



Features

1. Compact and handy size realize free direction of installation.
2. The completely sealed structure eliminates the need for resupplying the unit with operating oil and realizes stable speed control over a long time.
3. Stable feed speed is obtained as variation of the controlled speed is very little against sudden load changes.
4. Feed is controlled with ease by the speed adjusting knob.

Specifications

Model	Max. Stroke	Load Range	Range of Speed Control for Each Thrust	Permissible Impact Load	Weight (Main Body)
	mm		N		mm/sec
RB-2430	30	200~1,500	F= 200N 0.1~ 5 F= 490N 0.2~25 F= 980N 0.3~40 F= 1,500N 0.4~50	2.45	0.41
RB-2460	60		0.58		
RB-3140	40	490~2,900	F= 490N 0.1~10 F= 1,500N 0.2~25 F= 2,200N 0.3~35 F= 2,900N 0.5~40	3.92	0.95
RB-3160	60		1.20		

Note : Special models other than those in the above table are also available upon request.

Dimensions (mm)

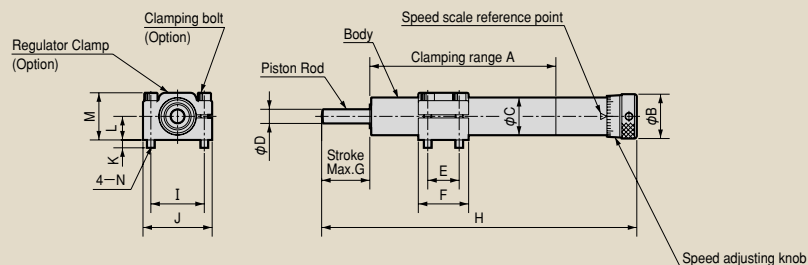

Model	A	B	C	D	E	F	G	H	I	J	K	L	M	N
RB-2430	115	28	24	9	20	32	30	200	34	44	5	15	30	M5
RB-2460	196						60	311						
RB-3140	150	36	31	12	24	40	40	270	42	58	7	20	40	M6
RB-3160	190						60	331						

R-Atype [Air Return Type]

In the hydro speed regulator R-A type, the position of the piston rod is maintained even if it is no longer loaded and the piston rod is returned to its original position by supplying external compressed air. Effective for step feed motion.

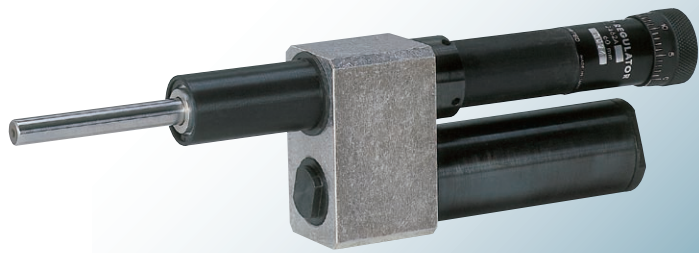

Features

1. With the position of the piston rod maintained along the stroke as desired, efficient step feeding is possible.
2. Some models feature a long stroke for expanded application purposes.

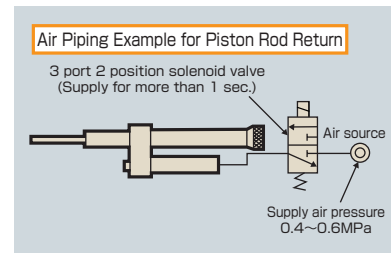
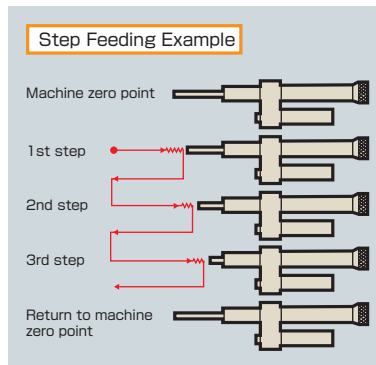

Specifications

Model	Max. Stroke	Load Range	Range of Speed Control for Each Thrust		Permissible Impact Load	Weight (Main Body)	
	mm		N	mm/sec		J	kg
R-2442A	40	200~1,500	F = 200N	0.3~5	2.45	1.3	
R-2462A	60		F = 980N	0.5~25		1.4	
R-2482A	80		F = 1,500N	0.8~30		1.5	
R-3182A	80	490~2,900	F = 490N	0.3~12	3.92	2.2	
R-31132A	130		F = 2,200N	0.5~25		2.8	
			F = 2,900N	0.8~30			

Note : Special models other than those in the above table are also available upon request.

Dimensions (mm)

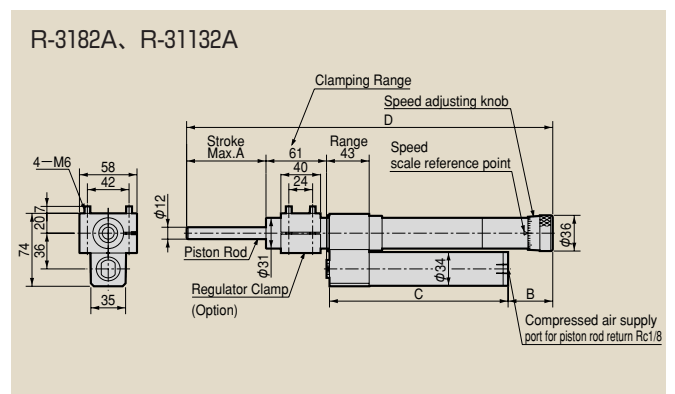
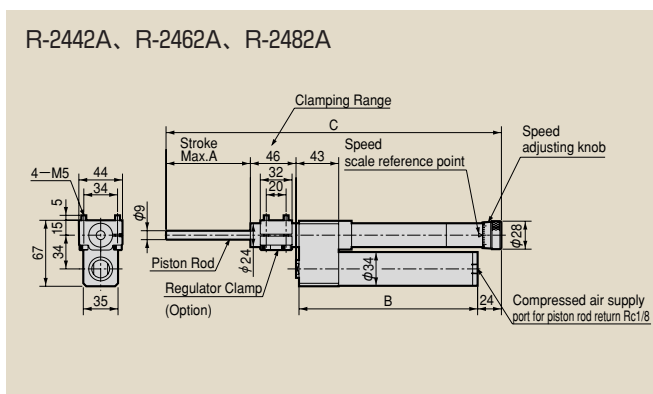

Model	A	B	C
R-2442A	40	127	240
R-2462A	60		260
R-2482A	80	180	333

Model	A	B	C	D
R-3182A	80	39	180	363
R-31132A	130	34	255	483

Adjustable Spindle Noses

Adjustable spindle noses are applicable to GSB and GSC type selfeeder global.

When ordering the Adjustable Spindle Nose type selfeeder global, please specify the model number of the spindle nose given in the below table.

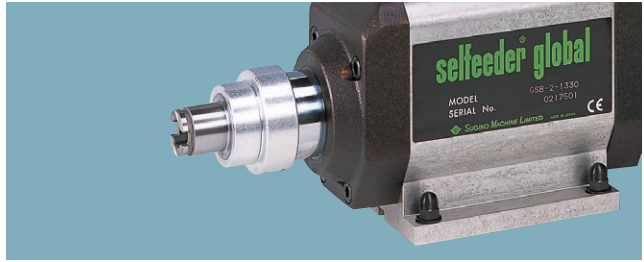

Dimensions (mm)

Fig. 1

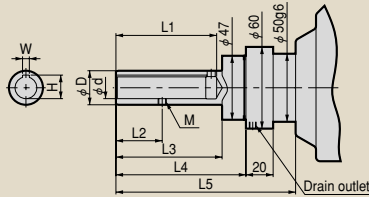

Fig. 2

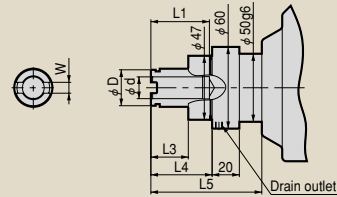

Fig. 3

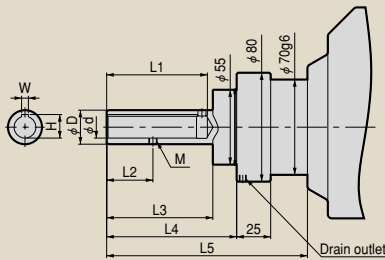
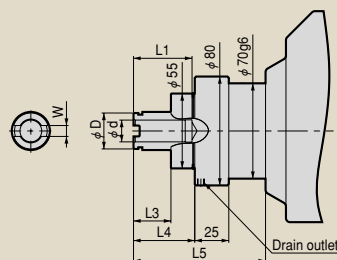

Fig. 4



Applicable selfeeder	Fig.No.	Spindle Nose Model No.	d	D	H ^{+0.1} ₀	W	L1	M	L2	L3	L4	L5
GSB type	1	BILZ16	16H6 ^{+0.011} ₀	25g6 ^{-0.007} _{-0.020}	17.3	5 ^{+0.145} _{+0.070}	74	M6×1	34	74	91.5	128
		BILZ20	20H6 ^{+0.013} ₀	32g6 ^{-0.009} _{-0.025}	21.3		77			77	131	
		BILZ25	25H6 ^{+0.013} ₀	37g6 ^{-0.009} _{-0.025}	26.7	6 ^{+0.145} _{+0.070}	85			M8×1.25	38	89
	2	KH-14E	14 ^{+0.010} _{+0.005}	22.0 ⁰ _{-0.1}	-	8C10 ^{+0.138} _{+0.080}	38	-	-	27.5	45	81.5
		KH-16E	16 ^{+0.010} _{+0.005}	26.4 ⁰ _{-0.1}			43					
		KH-22E	22 ^{+0.010} _{+0.005}	32.4 ⁰ _{-0.1}			58				51.5	
GSC type	3	BILZ16	16H6 ^{+0.011} ₀	25g6 ^{-0.007} _{-0.020}	17.3	5 ^{+0.145} _{+0.070}	74	M6×1	34	74	91.5	143.5
		BILZ28	28H6 ^{+0.013} ₀	40g6 ^{-0.009} _{-0.025}	29.7	6 ^{+0.145} _{+0.070}	85	M8×1.25	38	88	105.5	157.5
	4	KH-16E	16 ^{+0.010} _{+0.005}	26.4 ⁰ _{-0.1}	-	8C10 ^{+0.138} _{+0.080}	43	-	-	30	47.5	99.5
		KH-25E	25 ^{+0.010} _{+0.005}	37.4 ⁰ _{-0.1}			63			52	69.5	121.5

- Note 1. Dimensions of spindle shown here are as per recommendation of NT Tool Co., Ltd.
 2. Spindle noses of KH-E model are applicable to the quick change stub holder of KH-A or KH-E model of NT Tool Co., Ltd.
 3. Adjustable spindle noses cannot be installed on selfeeder global which will operate at 5,000 min⁻¹ or above.
 4. Adjust the direction so that the drain outlet facing downward, when installing selfeeder global in a horizontal position.
 5. Specific products other than shown above are also available upon your requests.

Collet Chuck Spindle Noses

Collet chuck spindle noses applicable to ER Collet of REGO-FIX Co., Ltd. are available for all types of selfeeder global. When ordering the Collet Chuck Spindle Nose type selfeeder global, please specify the model number of the spindle nose given in the below table.

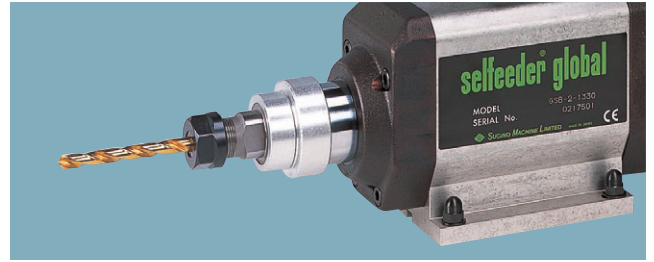

Dimensions (mm)

Fig. 1

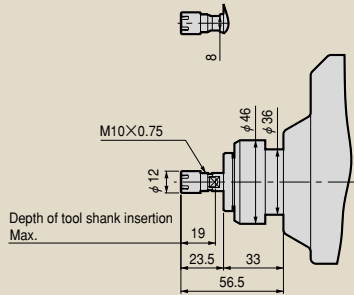

Fig. 2

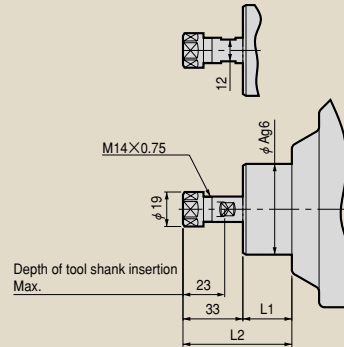

Fig. 3

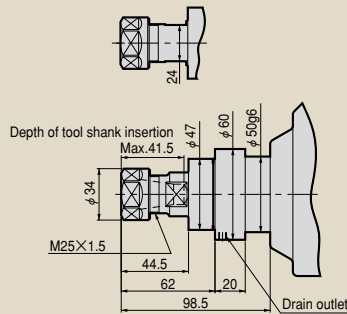
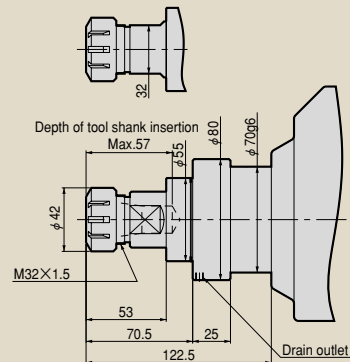

Fig. 4



Applicable selfeeder	Fig.No.	Spindle Nose Model No.	Chucking Range	L1	L2	A	
GSA type	1	ER 8	0.5~ 5	—	—	—	
GSB-2-	2	ER11	0.5~ 7	27	60	50	
							6075 (L) 6060 (L) 6046 (L)
GSB-4-	3	ER20	1~13	—	—	—	
							1330 (L) 1320 (L) 1315 (L) 1312 (L)
GSC-2-	4	ER25	1~16	—	—	—	
							1337 (L) 1330 (L) 1323 (L) 1315 (L) 1310 (L) 1307 (L) 1306 (L)
							1361 (L) 1342 (L)
							1330 (L) 1321 (L) 1315 (L)
GSC-4-	4	ER25	1~16	—	—	—	
GSC-4-	4	ER25	1~16	—	—	—	
							1330 (L) 1321 (L) 1315 (L) 1311 (L) 1307 (L)

Note 1. Dimensions of spindle shown here are as per recommendation for ER collet of REGO-FIX Co., Ltd..

2. Collet, Collet nut and spanner are not supplied as standard one. Please order if required.

3. Adjust the direction so that the drain outlet facing downward, when installing selfeeder global in a horizontal position.

Flex Stands

The Flex stand is a jig for fixing GSA type, GSB type and GSB-L type of selfeeder global at a desired angle of operation.

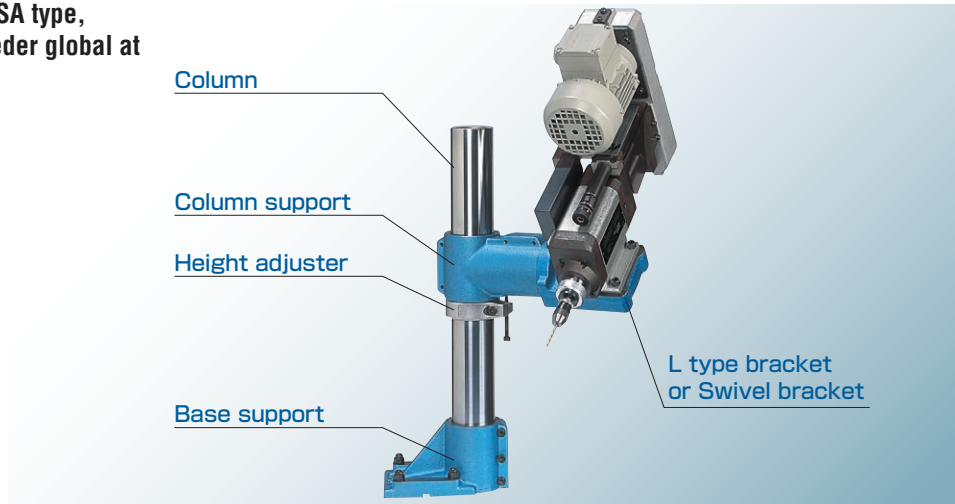

Dimensions (mm)

L type bracket
US-74LBK

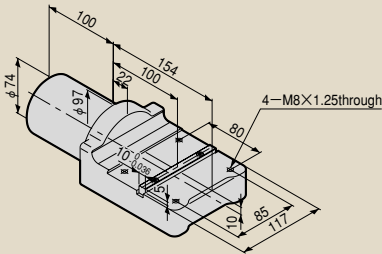

L type bracket
US-92LBK

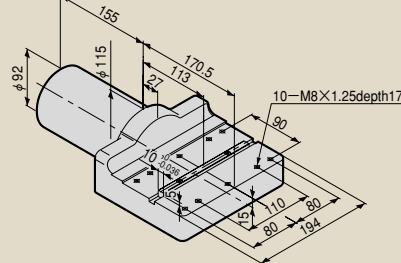

Swivel bracket
US-74SBK

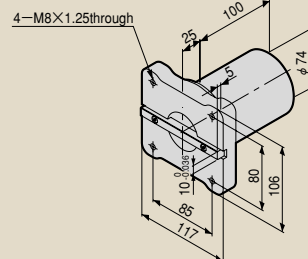

Swivel bracket
US-92SBK

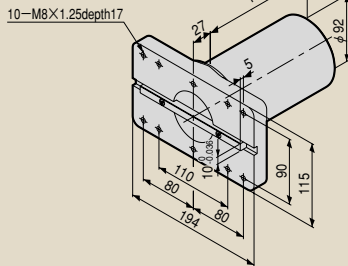

Base support
FS-74BS

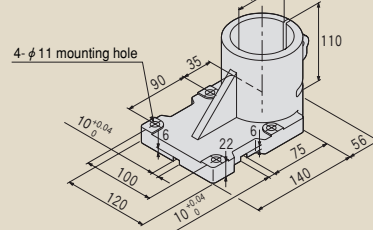

Base support
US-92BC

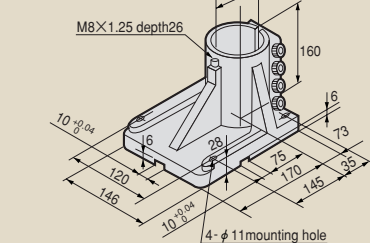

Column support
FS-74CS
US-92CC

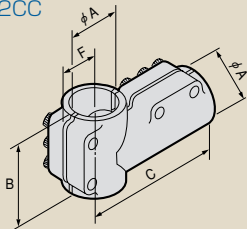

Column
FS-74C
FS-92C

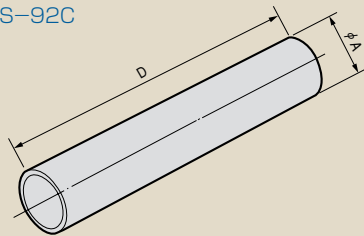

Height adjuster
US-74HA
US-92HA

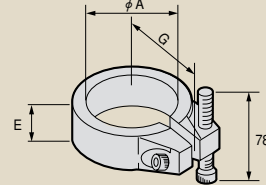

Model	A	B	C	D	E	F	G	Applicable selfeeder
FS-74 US-74	74	110	140	600	30	56	65	GSA type
FS-92 US-92	92	160	205	800	34	70	78	GSB type, GSB-L type

Note : GSC type and GSC-L type are not suitable for the Flex stand as they are heavy.

Step Controller

Measures must be taken to prevent the wear and fracture of the drill in such machining processes as drilling a hole with a depth exceeding 5 to 6 times the drill diameter.

Step controller MCB-1 is the controller to materialize the easy operation of the step-feed and inching drilling by selffeeder global.

Features

1. Optimum cutting condition settings.

The controller is equipped with three timers which realize the fine adjustment and the optimum cutting condition settings.

Fine inching feed is possible through timer adjustment.

2. Light weight and compact size.

The controller is compact design and can be installed in an operation panel.

3. Complete variety of output signals.

Various types of output signals such as for start point, maximum drilling depth and in-process checking are equipped.

The synchronized operation with other equipment is possible.



Drilling Motion

Step Feed Pattern

The 1st step, T1, completes the first step machining and the 2nd step and following steps are controlled by T3 which drills little by little in the optimum cutting conditions. The return timer, T2, helps selffeeder global work immediately on the next step without returning it to the machine zero point, thus performing efficient deep hole drilling.

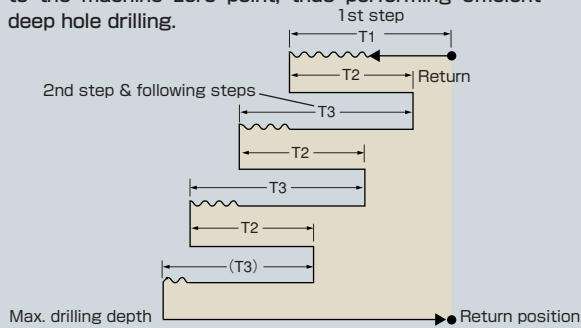

Inching Feed Pattern

Inching feed results from setting the return timer, T2, at a short period. Chips are broken down and the cutting torque on the drill bit is reduced. Thus, the life of drill is extended.

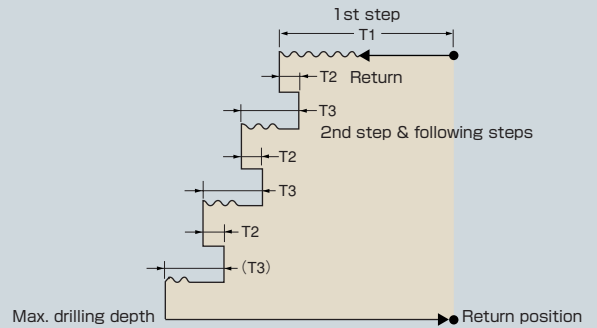

Dimensions (mm)

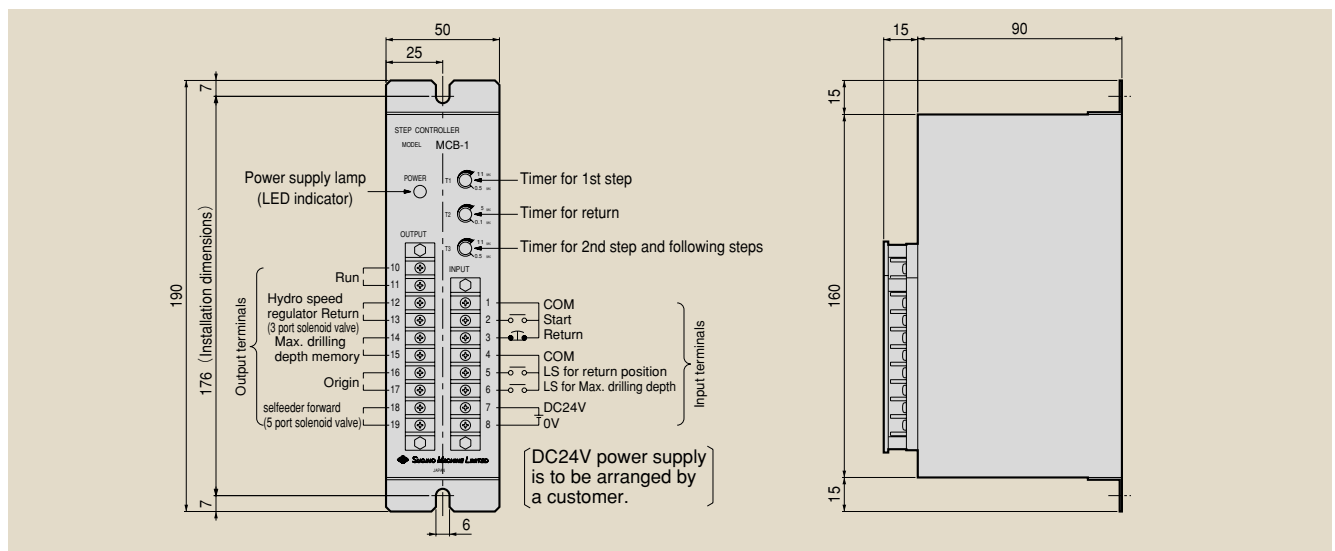

Applications

Variety of option items are available for the high-efficiency and high-accuracy.

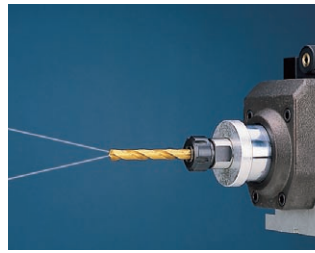

Through-The-Tool Coolant Supply

The high pressure coolant through the tools can be used by an optional hole through the spindle.

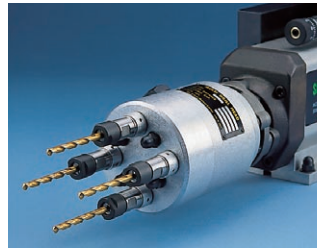

Multi Spindle Head

High efficiency drilling can be materialized with Sugino's Multi Spindle Head.

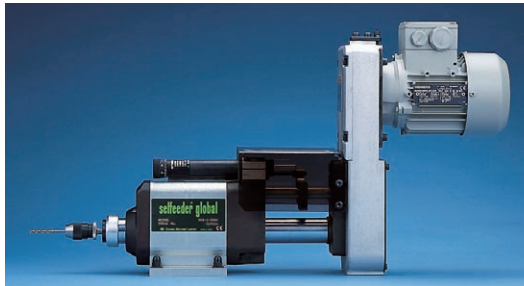

Motor Mounting Flexibility

The spindle motor can be mounted behind the unit or at 90° to the left or right of the unit according to the machine layout.



Standrill

Standrill is the high accuracy automatic drill press type stand with the up-and-down control and the head-swing control.

Specifications

Models	SSD-74
Applicable selfeeder	selfeeder global
	· GSA type series
	· GSB type series
Up-down stroke of the unit	Max.260mm
Allowable unit weight	Max.45kg

SUGINO MACHINE LIMITED

<http://www.sugino.com>

1-9-13, Nihonbashi-Honcho, Chuo-ku, Tokyo, 103-0023 JAPAN

☎+81-3-5201-5974 FAX+81-3-5201-5978

e-mail : export@sugino.com

Overseas Office

U.S.A.

Sugino Corp.

+1-630-250-8585 FAX+1-630-250-8665
e-mail : mach@suginocorp.com

Mexico

Sugino Machine Mexico, S.A. de C.V.

+52-81-1100-0108 FAX+52-81-1100-0318
e-mail : ventas@sugino.com.mx

China

Sugino Shanghai Co., Ltd.
Shanghai office

+86-21-5385-5031 FAX+86-21-5385-5032
e-mail : sh@sugino.cn

Guangzhou office

+86-20-8363-4719 FAX+86-20-8363-4992

Thailand

Sugino Machine (Thailand) Ltd.

+66-3572-9351 FAX+66-3572-9355
e-mail : contact@sugino.th.com

Singapore

Sugino Machine Singapore Pte. Ltd.

+65-6458-9544 FAX+65-6456-7789
e-mail : sales@sugino-singapore.com.sg

Czech Rep.

Sugino Machine Limited-
Prague, Branch Office

+420-257-950-228 FAX+420-257-950-044
e-mail : info@sugino.cz

※ Specifications in this catalogue are subject to change without prior notice for further improvement.

This product and other related technology (include the program) are subject to the terms and conditions of the relevant foreign trade acts depending on end users and their applications.

All the relevant forms must be submitted to the Japanese government, including the application to export technology.

The content of this catalogue is as of August 2011.

Any unauthorized use, copying or reprinting of the contents or part thereof in this catalogue is prohibited.