



Machining Application of the Month

SOLUTION: SERVO-FEED VARIMEC™ SELF FEEDERS ANSWER DEMANDING QUESTIONS TO HOLEMAKING PROBLEMS

Programmable, Single-Servo Z-Axis Machining Center

Lower Burden rate than CNCs

Simultaneous Multi-Perimeter Drilling & Milling

Machining Center Accuracy

Reduced Cycle Time

Deep Hole Accuracy



Automotive Valve Body

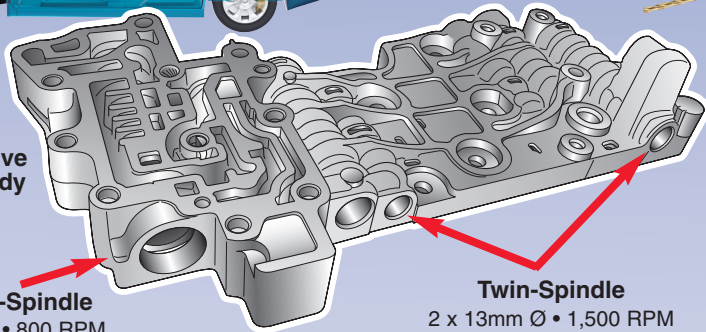

Single-Spindle
21mm Ø • 800 RPM
0.1mm/Rev

Twin-Spindle
2 x 13mm Ø • 1,500 RPM
0.1mm/Rev

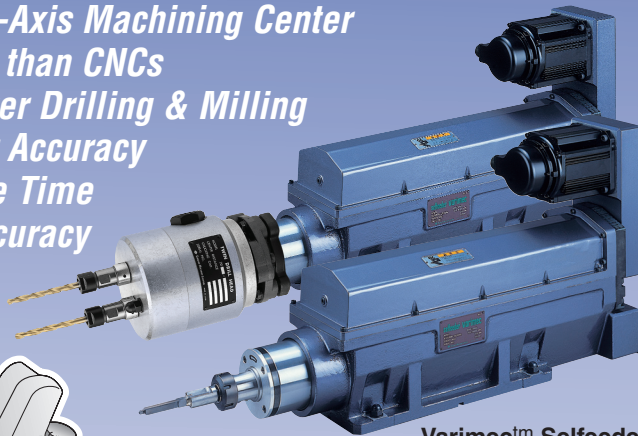

Varimec™ Selffeeder
3.25 HP • 0.0002" TIR
11.81" stroke with linear
slide & ballscrew



Sugino Corp.

Itasca, IL 60143 • 1 (888) Sugino 1 • www.suginocorp.com