

# TECNA DIRECT.COM

STOCKING IMPORTER

MASTER DISTRIBUTOR

**AHB**  
TOOLING & MACHINERY

COMPLETE METALWORKING SOLUTIONS  
(800) 991-4225      www.ahbinc.com  
ISO Certified      customerservice@ahbinc.com

POWERED BY:

WSI

WELD  
SYSTEMS  
INTEGRATORS, INC.

RESISTANCE WELDING. SOLVED.

## PRESS and ROCKER ARM

### 50 kVA · PEDESTAL SPOT WELDERS

Pneumatic Operated Dual Voltage · Model #: 4662 and 4666



Main: 844-44-TECNA  
International: +1-216-475-5629  
www.TECNADirect.com

TECNA Pedestal Welders, Portable Spot Welding Guns, Bench Welders,

Tool Balancers, Accessories, Spare Parts, Service and Support!

# TECNA PRESS AND ROCKER ARM WELDERS

Pneumatic Operated and Dual Voltage | 50 kVA

## AIR OPERATED WELDERS

- Air-Operated, lube-free cylinder eliminates oil mist in the shop environment.
- Electrode force is adjustable via integrated filter / regulator combination.
- Reduce shop noise with integrated speed control valves, shock absorber for end of cylinder stroke, and air exhaust mufflers.
- Two-stage electronic footswitch initiation (1st stage closes tips without welding, 2nd stage initiates weld schedule.)
- Pre-wired to accept a second footswitch, Option 72977. A second footswitch allows for immediate recall of a second weld time / current setting. This is helpful when different settings are required on the same workpiece.
- SAFETY OPTION: WSI-supplied TECNA Welders are available with UNITROL SOFT TOUCH Safety for pinch point protection.
- Fixed retraction stroke. Manual (standard) or foot pedal actuation (optional).



## 4662 ADJUSTABLE ARMS

- Arm depth is adjustable by up to 12.6" (320mm) depending on your working requirements.
- Adjustable Drop Arm Assembly, Option 4638, is available on all models. Note that larger arm gap reduces available welding current. The greater the spacing between the arms, the lower the welding current available at the electrodes.

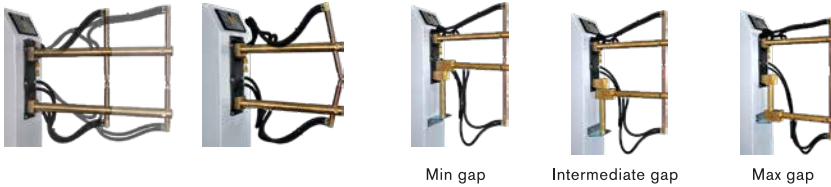

## OPTIONAL ACCESSORIES



Insulated serial interface RS232, enabling the direct connection to a printer or PC. Only with optional TE550 control. **Option 50214.**



USB interface board. **Option 4639.**



Two-hand safety control on pedestal, adjustable height. Recommended for operator safety depending upon working requirements. Only with optional TE550 control. **Option 72628.**



Additional foot-pedal for program no. 2. **Option 73070.**



Optional foot-pedal for retraction stroke Only with optional TE550 control. **Option 4635 / 4636.**

Single Footswitch (standard) as on 20kVA.

SPECIFICATION	UNITS	WTR		WTP	
		4662	4662	4666	4666
Power @ 50% Duty Cycle	kVA	50		50	
Max Power	kVA	104		84	
Secondary Voltage	V	6.1		6.1	
Maximum Short Circuit Current	A	21,000		17,000	
Thermal Current @ 100%	kA	5.7		5.7	
Supply Voltage (@60Hz)*	Dual Voltage	230/440		230/440	
Delayed Fuses @ 230VAC	A	175		125	
Delayed Fuses @ 440VAC	A	100		70	
Primary Cables Ø (up to 30m)	mm	35		35	
Includes OSHA-Preferred LOTO-Compliant Air Lockout		Yes	No	Yes	No
Compressed Air Supply	psi (bar)	94 (6.5)		94 (6.5)	
Air Consumption per 1000 Spots @ 650kP (6.5 bar)	SCF (N/m)	219-159 (6.2-4.8)		191-60 (5.4-1.7)	
Arm Minimum Length	in (mm)	11 (280)		15.7 (400)	
Max Electrode Force (6.5 bar)	lbs. (daN)	935 (425)		1034 (470)	
Working Stroke	in (mm)	0.2-2 (5-50)		0.2-3.2 (5-80)	
Arm Maximum Length	in (mm)	23.6 (600)		-	
Max Electrode Force (6.5 bar)	lbs. (daN)	462 (210)		-	
Working Stroke	in (mm)	0.2-3.7 (95)		-	
Short Circuit Current with Arms @ Max Length	kA	14.3		-	
<b>Adjustable Arm Gap Assembly (OPTION 4638)</b>					
Short Circuit Current with Arms @ Max Gap	A	12,600		-	
Minimum Gap	in (mm)	7.7 (195)		-	
Maximum Gap	in (mm)	19.7 (500)		-	
Water Cooling @ 250 kP (2.5 bar)	gpm (lpm)	1.1 (4)		1.1 (4)	
Minimum Water Pressure	psi (bar)	36 (2.5)		36 (2.5)	
Aerial Noise Produced	dB(A)	<70		<70	
<b>Measured Conditions</b>					
Working Stroke	in (mm)	20		20	
Welding Time	Cycles	15		23	
Welding Current	kA	16		12.7	
Working Rating (Welds per Minute)	#/min	15		15	
Net Weight	lbs (kg)	502 (228)		495 (225)	
Ø Arms	in (mm)	1.97 (50)		1.97 (50)	
Ø Electrode Holders		1"		1"	
Electrode Taper Size		5RW/2MT		5RW/2MT	
Compatible with North American Holders/Electrodes?		Yes	No	Yes	No

\*May be supplied capable of operating on other voltages/frequencies. Please ask for details.

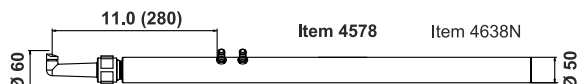
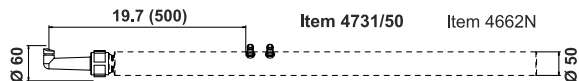

Fits drop arm assembly ONLY.

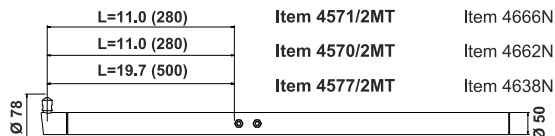

Fits drop arm assembly ONLY.

## ROCKER ARM SPOT WELDERS

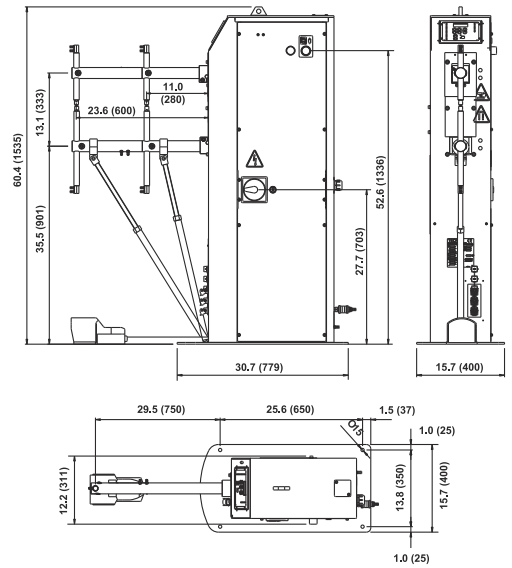

## PRESS TYPE SPOT WELDERS

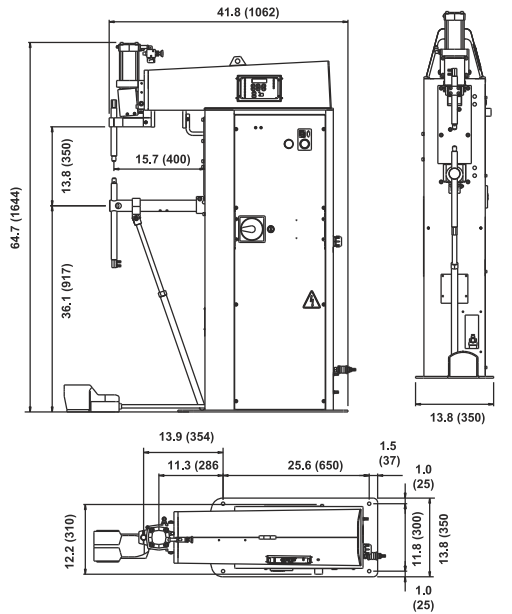

## ADJUSTABLE ARMS - DROP ARM ASSEMBLY (Option 4638)

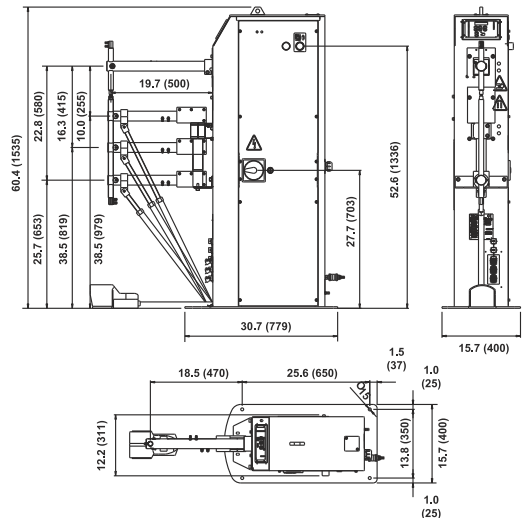

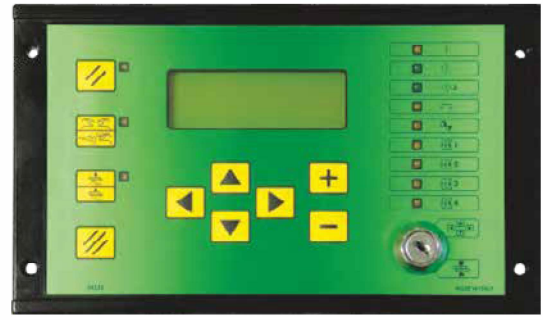

Programmable Parameters	TE101 (standard)	TE550 (option 4637N)	TE550 (option 4637N + option 4634)
Type of Control	Pulse Width (Standard)	Constant Current	Constant Energy
Constant Current	No	Yes	
Constant Energy	No		Yes
Secondary Current Monitoring (Rogowski Coil)	Yes		
Basic Secondary Current Compensation	Yes		
Number of Parameters in Weld Program	13	26	26
Number of Programs Available	99	250	250
Number of Welding Programs Selectable by Foot Pedal	2		
RS232 or USB Interface Available (Optional)	RS232 Only	RS232 or USB	
Allows Programming in Half-Cycles	Yes		
Heat Stepper Function	No	Yes	
Weld Counter	No	Yes	
Maximum Weld Count	No	Yes	
Dual-Palm Button Initiation	No	Yes	
End Of Cycle/Interlock Output	End of Cycle Only	End of Cycle and Interlock Outputs	
High/Low Weld Current Limits	Yes		
Output signal for Out of Limits Welds	Yes		

**TECNA DIRECT.COM**

STOCKING IMPORTER || MASTER DISTRIBUTOR

POWERED BY:  
**WSI** WELD SYSTEMS INTEGRATORS, INC.  
 RESISTANCE WELDING. SOLVED.

4943 Driscoll Road · Warrensville Heights, OH 44146 USA

Spot | Projection | Seam | Butt | Capacitor Discharge  
 Resistance / MIG / TIG / Plasma Automation & Robotics  
 Consumables | Accessories | Engineering | Service



DISTRIBUTED BY:



**COMPLETE  
 METALWORKING  
 SOLUTIONS**

(800) 991-4225

www.ahbinc.com  
 ISO Certified  
 customerservice@ahbinc.com