



A GLOBAL PROVIDER OF ENHANCED THERMAL CUTTING SOLUTIONS

# EX-TRAFIRE<sup>®</sup>

PLASMA CUTTING SYSTEMS CATALOG



TOOLING & MACHINERY

COMPLETE METALWORKING SOLUTIONS

(800) 991-4225

[www.ahbinc.com](http://www.ahbinc.com)

ISO Certified

[customerservice@ahbinc.com](mailto:customerservice@ahbinc.com)



Thermacut<sup>®</sup> - THE CUTTING COMPANY<sup>®</sup>

[WWW.THERMACUT.COM](http://WWW.THERMACUT.COM)  
[SALES@THERMACUT.COM](mailto:SALES@THERMACUT.COM)

© 2015 Thermacut, Inc. 1000US

# FROM THE WORKSHOP TO THE SHIPYARD.

“A successful product begins with a simple idea”.

The idea was to create a plasma cutting power supply with precisely set criteria. It had to be powerful, versatile, easy to operate, durable and portable.

WE CREATED IT.  
IT'S CALLED  
THE **EX-TRAFIRE**®

EX-TRAFIRE® PLASMA SYSTEMS

## TABLE OF CONTENTS

### OVERVIEW

#### EX-TRAFIRE®85HD

System <b>SPECIFICATIONS</b>	6-11
FHT-EX®105TT <b>PLASMA TORCH</b>	12-19

#### EX-TRAFIRE®105HD

System <b>SPECIFICATIONS</b>	20-25
FHT-EX®105TT <b>PLASMA TORCH</b>	26-35

#### EX-TRAFIRE®125HD

System <b>SPECIFICATIONS</b>	36-41
FHT-EX®125TT <b>PLASMA TORCH</b>	42-51



# EX-TRAFIRE<sup>®</sup> HD

**INDUSTRIAL CUTTING. HEAVY-DUTY PERFORMANCE.**

EX-TRAFIRE<sup>®</sup> 105HD

# EX-TRAFIRE® 85HD

**INDUSTRIAL CUTTING.  
HEAVY-DUTY PERFORMANCE.**



SOLUTIONS / INDUSTRIES



Training and education



General fabrication



Craft, hobby and non-industrial



Structural

# EX-TRAFIRE® 85HD



CUTTING  
**85 A**  
CURRENT

MATERIAL  
**2 inches**  
THICKNESS

LIGHTWEIGHT  
**66 lbs**

## IMPRESSIVE PERFORMANCE



- + For handheld and mechanized use
- + Industry leading cut capacity
- + 100% Duty cycle
- + Use in applications ranging from the workshop to the shipyard

## READY FOR INDUSTRY 4.0



- + CAN Bus interface (optional)
- + RS 485 interface (optional)
- + Easy monitoring
- + Expandable for future applications

## AUTOMATIC SETTINGS



- + Automated settings for cutting parameters
- + Pressure regulation keeps cuts precise and arc stable
- + Fewer operating errors, better cutting quality

## OPTIMAL COST-EFFECTIVENESS



- + Low investment costs
- + 20 % longer consumable lifetime
- + Low operating costs
- + Increased productivity

# EX-TRAFIRE® 85HD

## SPECIFICATIONS

Cutting current	20-85 A
Modes	Cutting / Gouging / Grid / Marking
Duty cycle @ 104 °F	
U1 - 1 x 230 VAC	60% - 62A, 100% - 50A
U3 - 3 x 208 VAC	40% - 85A, 100% - 54A
U3 - 3 x 460 - 575 VAC	80% - 85A, 100% - 76A
Rated output voltage [V]DC	140
Severance cutting capacity*	2"
Piercing cutting capacity*	3/4"
Gouging Removal	17 lbs/hr
Recommended cutting capacity*	1 - 1/8"
Plasma gas	Air / Nitrogen / Argon**
Air flow cut pressure	75 PSI
CAN, RS 485, RS 422	optional
Preadjusted voltage divider ratio***	50:1
Input voltage [V]AC	1 x 200 - 240 / 3 x 208 - 575 ± 15%
Frequency	50/60 Hz
Dimensions LxWxH [inch]	22" x 10" x 16"
Weight	66 lbs
Certification depending on region	CSA
Recommended Min/Max Pressure	90-145 PSI
Protection level	IP23S
Insulation class	F
Type of hand torch	FHT-EX®105TTH
Type of machine torch	FHT-EX®105TTM

\*values for low alloy steel, e.g. MS S235JR  
 \*\*used for optional fine marking  
 \*\*\*part of optional CNC interface  
 \*\*\*\* I2 reduced to 65A at single phase input voltage





## 4 DIFFERENT OPERATION MODES

The plasma cutting systems in the EX-TRAFIRE®HD range excel at meeting demanding requirements during continuous operation. The portable EX-TRAFIRE®85HD plasma cutting system, with a 100% duty cycle, is the perfect solution for challenging heavy-duty industrial applications.

  
**CUTTING**

  
**GRID CUTTING**

  
**MARKING**

  
**GOUGING**

# EX-TRAFIRE® 85HD

## ORDERING INFORMATION

Description	Length	Part No.
<b>MANUAL PLASMA CUTTING SYSTEMS</b>		
EX-TRAFIRE®85HD/CSA/200-600V Hand System/FHT-EX®105TTH Torch 16.4ft/H Starter Kit	16.4 ft	EX-4-010-061
EX-TRAFIRE®85HD/CSA/200-600V Hand System/FHT-EX®105TTH Torch 26.2ft/H Starter Kit	26.2 ft	EX-4-010-062
EX-TRAFIRE®85HD/CSA/200-600V Hand System/FHT-EX®105TTH Torch 49.2ft/H Starter Kit	49.2 ft	EX-4-010-063
<b>MECHANIZED PLASMA CUTTING SYSTEMS</b>		
EX-TRAFIRE®85HD/CSA/200-600V 3-PH Machine System/FULLY EQUIPPED/FHT-EX®105TTM STD-NR Torch 26.2ft/M Starter Kit	26.2 ft	EX-4-011-042
EX-TRAFIRE®85HD/CSA/200-600V 3-PH Machine System/FULLY EQUIPPED/FHT-EX®105TTM STD-NR Torch 49.2ft/M Starter Kit	49.2 ft	EX-4-011-043
EX-TRAFIRE®85HD/CSA/200-600V 3-PH Machine System/STD EQUIPPED/FHT-EX®105TTM STD-NR Torch 26.2ft/M Starter Kit	26.2 ft	EX-4-013-014
EX-TRAFIRE®85HD/CSA/200-600V 3-PH Machine System/STD EQUIPPED/FHT-EX®105TTM STD-NR Torch 49.2ft/M Starter Kit	49.2 ft	EX-4-013-015

### PLASMA CUTTING UNITS

EX-TRAFIRE® 85HD/CSA/200-600V 3-PH power supply unit/FULLY EQUIPPED	EX-4-001-009
EX-TRAFIRE® 85HD/CSA/200-600V 3-PH power supply unit/STD EQUIPPED	EX-4-003-005

\* Fully-equipped=CNC interface & Serial interfaceport (CAN bus)  
 \*\* STD-equipped=CNC interface

## ACCESSORIES

Description	Pcs	Part No.
DN 7.2 ES Quick Connect Plug with female thread G 1/4"	1	EX-0-802-000
DN 7.2 ES Quick Connect Plug with male thread G 1/4"	1	EX-0-802-001
DN 7.2 ES Quick Connect Coupling with male thread G 1/4"	1	EX-0-802-002
Grease .8 oz	1	EX-0-805-001
Filter-EX Compressed Air Filter	1	EX-0-804-001
Filter-EX Air Filter Cartridge	8	EX-0-804-002

# EX-TRAFIRE® 85HD



FRONT VIEW



BACK VIEW



SIDE VIEW

# FHT-EX® 105TT



# FHT-EX® 105TTH

## HAND TORCH ASSEMBLY



Item	Part No.	Description	Pcs
1.	EX-5-139-001	FHT-EX®105TTH Hand Torch Assembly-w/o consumables w/5m (16.5') Lead/TCS13	1
	EX-5-139-002	FHT-EX®105TTH Hand Torch Assembly w/o consumables w/8m (26') Lead/TCS13	1
	EX-5-139-003	FHT-EX®105TTH Hand Torch Assembly w/o consumables w/15m (50') Lead/TCS13	1
	EX-5-139-004	FHT-EX®105TTH Hand Torch Assembly w/o consumables w/23m (75') Lead/TCS13	1
2.	EX-0-321-003	Latch with Key Assembly	1

⊕ LATCH WITH KEY IS NOT CONTENT OF TORCHES ABOVE. IF YOU NEED IT, YOU HAVE TO ORDER SEPARATELY.



The high-performing FHT-EX®105TT H/M hand and machine torches meet the tough demands of continuous operations. Designed for optimal use with EX-TRAFIRE®85HD for cutting, gouging, grid-cutting and marking, while allowing cut thickness up to 2 inches with greater precision and speed.

With the Thermacut® Torch Connection System (TCS), changing the torch is a quick and easy process. Resulting from decades of experience in the field of plasma cutting, the power supplies features an extremely robust and durable design supported by consumables that can be replaced quick and easily.

### BENEFITS

- High-performance torches for mechanized applications and handheld use
- Ergonomic handheld torches that increase time cutting safely in all positions
- Compact and flexible for handheld applications, even with a tight radius or the gouging of fillet welds
- 100 % duty cycle at 76A for continuous use
- Capable of plate thicknesses up to 2 inches
- Extended life consumables
- Quick and tool-free replacement of consumables
- Piercing capability up to 3/4 of an inch

# FHT-EX® 105TTH

## HAND TORCH COMPONENTS



Item	Part No.	Description	Pcs	Item	Part No.	Description	Pcs
1.	EX-5-374-010	FHT-EX®105TTH Hand Torch Lead Replacement 5m (16.5')/TCS13	1	8.	EX-0-325-005	Male Crimp Pin for TCS Plug	1
1.	EX-5-374-011	FHT-EX®105TTH Hand Torch Lead Replacement 8m (26')/TCS13	1	9.	EX-0-323-001	TCS13 Plug Body	1
1.	EX-5-374-012	FHT-EX®105TTH Hand Torch Lead Replacement 15m (50')/TCS13	1	10.	EX-5-302-001	Hand Torch Body Repl. Kit (incl. Torch body & Cap sensor)	2
1.	EX-5-374-013	FHT-EX®105TTH Hand Torch Lead Replacement 23m (75')/TCS13	1	11.	EX-5-431-050	O-Ring (fitted on the torch body) - 2 pcs	1
2.	EX-5-318-001	TCS Plug Spring Strain Relief	1	12.	EX-5-314-001	Hand Torch Handle Replacement Kit	1
3.	EX-0-325-015	TCS Clam Shell Screw Kit (incl. 4 screws)	1	13.	EX-5-305-002	Cap-sensor Replacement Kit with Screws/ Hand Torch	1
4.	EX-0-325-002	TCS Clam Shell Upper	1	14.	EX-5-313-031	Safety Trigger	1
5.	EX-0-325-001	TCS Clam Shell Lower	1	15.	EX-5-308-001	Hand Torch Handle with Screws	1
6.	EX-0-325-010	Retaining Ring (Outer circlip ring)	1	16.	EX-5-372-010	Cathode mounting kit	1
7.	EX-0-325-009	O-Ring (fitted in the TCS plug)	1	17.	EX-0-321-003	Latch w/Key Assembly	
				18.	EX-5-313-030	Safety Trigger Micro-Switch	

# CONSUMABLES

## HAND TORCH CONSUMABLES - 45-85 A

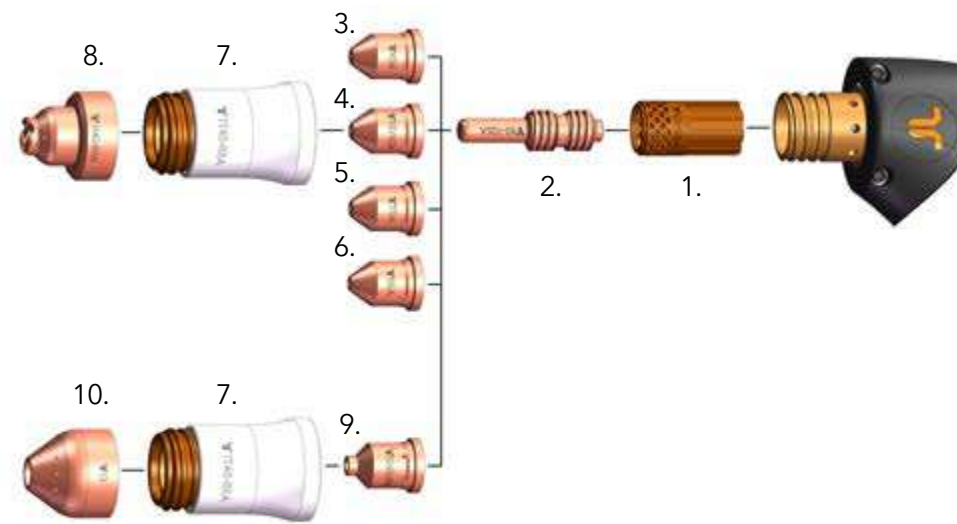

Item	Part No.	Description	Pcs	Item	Part No.	Description	Pcs
1.	EX-5-404-051	Swirl Ring 45-105 A	1	6.	EX-5-410-055	Nozzle 85 A	1
2.	EX-5-401-051	Electrode 45-105 A (pkg.5pcs)	1	7.	EX-5-415-050	Nozzle Retaining Cap 45-85 A	1
3.	EX-5-410-051	Nozzle 45 A	1	8.	EX-5-422-031	Hand Shield 45-85 A	1
4.	EX-5-410-053	Nozzle 55/65 A	1	9.	EX-5-440-051	Gouging Nozzle 45-85 A	1
5.	EX-5-410-030	Nozzle 75 A	1	10.	EX-5-440-050	Gouging Shield	1

## HAND TORCH CONSUMABLES - SMOOTHLINE

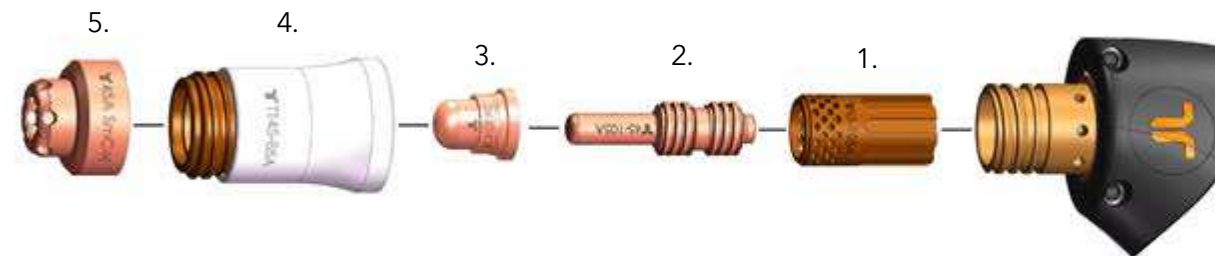

Item	Part No.	Description	Pcs
1.	EX-5-404-051	Swirl Ring 45-105 A	1
2.	EX-5-401-051	Electrode 45-105 A (pkg.5pcs)	1
3.	EX-5-410-050	Nozzle Smoothline	1
4.	EX-5-415-050	Nozzle Retaining Cap 45-85 A	1
5.	EX-5-420-050	Hand Shield 40/45 A Smoothline	1



# FHT-EX® 105TTM

## MACHINE TORCH ASSEMBLY

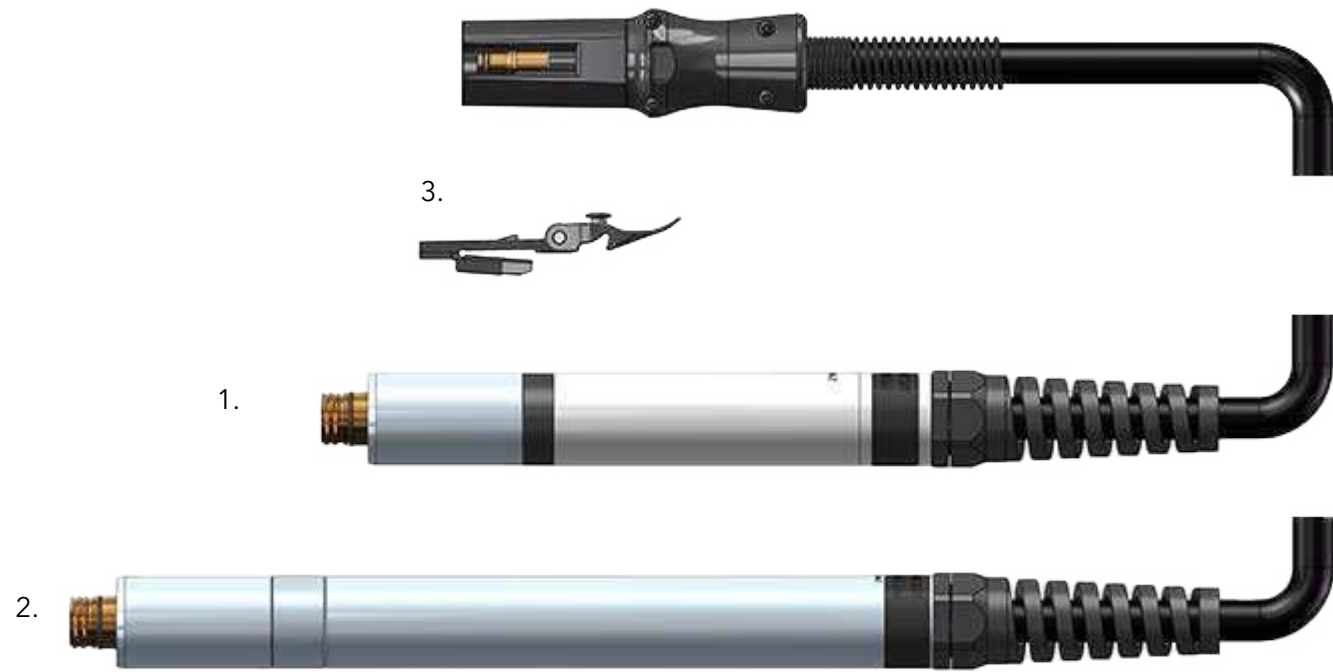

Item	Part No.	Description	Pcs
1.	EX-5-242-021	FHT-EX®105TTSM Short Machine Torch Assembly-w/o consumables w/5m (16.5') Lead/ TCS13	1
1.	EX-5-244-021	FHT-EX®105TTSM Short Machine Torch Assembly-w/o consumables w/8m (26') Lead/ TCS13	1
1.	EX-5-247-021	FHT-EX®105TTSM Short Machine Torch Assembly-w/o consumables w/15m (50') Lead/ TCS13	1
1.	EX-5-250-021	FHT-EX®105TTSM Short Machine Torch Assembly-w/o consumables w/23m (75') Lead/ TCS13	1
2.	EX-5-202-031	FHT-EX®105TTM M Torch w/o Rack Assy w/o consumables w/5m (16.5')Lead/ TCS13	1
2.	EX-5-204-031	FHT-EX®105TTM M Torch w/o Rack Assy w/o consumables w/8m (26') Lead/ TCS13	1
2.	EX-5-207-032	FHT-EX®105TTM M Torch w/o Rack Assy w/o consumables w/15m (50') Lead/ TCS13	1
2.	EX-5-210-034	FHT-EX®105TTM M Torch w/o Rack Assy w/o consumables w/23m (75') Lead/ TCS13	1
3.	EX-0-321-003	Latch with Key Assembly	1

⊕ LATCH WITH KEY IS NOT CONTENT OF TORCHES ABOVE. IF YOU NEED IT, YOU HAVE TO ORDER SEPARATELY.

# FHT-EX® 105TTM

## MACHINE TORCH COMPONENTS

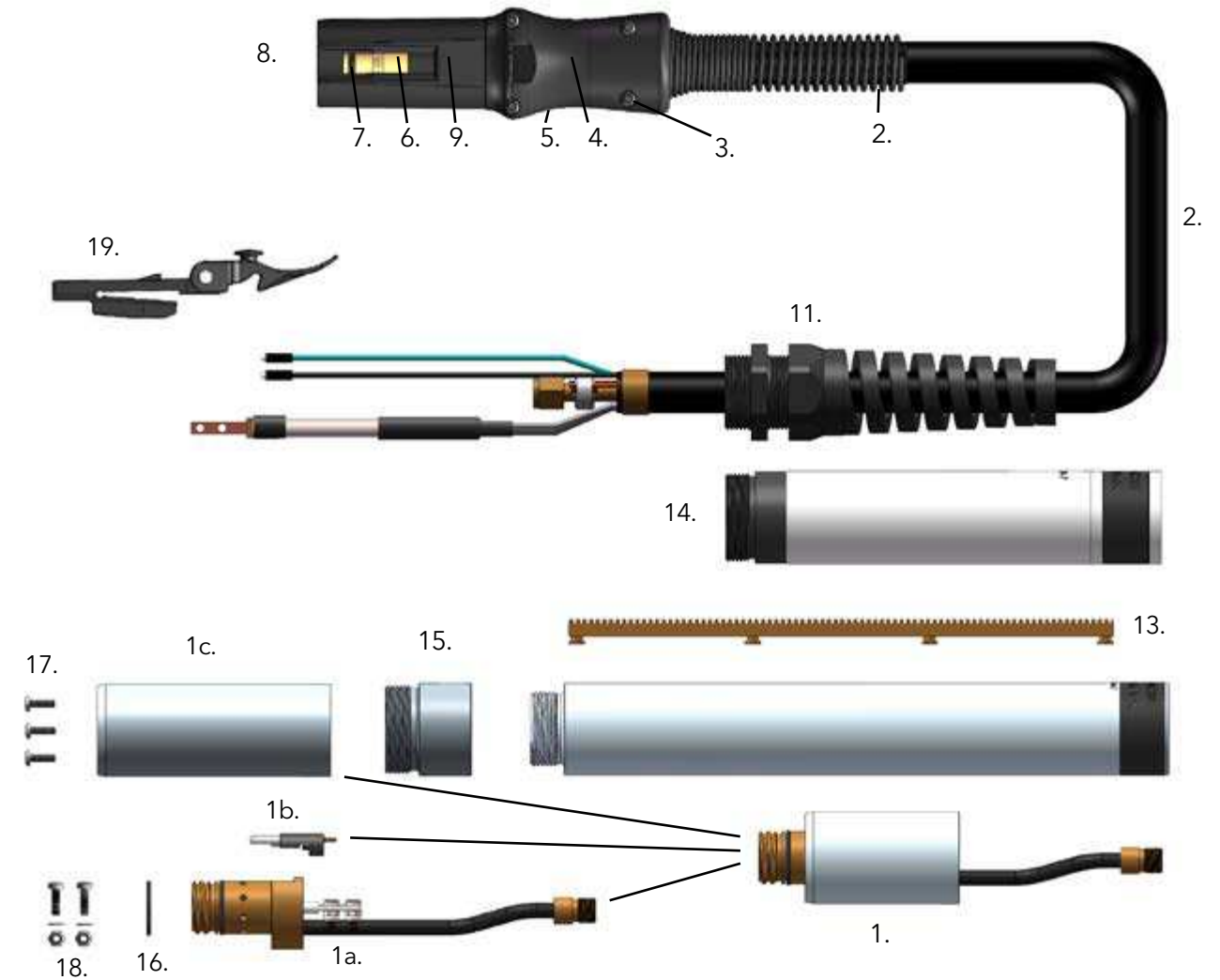

Item	Part No.	Description	Pcs	Item	Part No.	Description	Pcs
1.	EX-5-303-011	Machine Torch Body Assembly FHT-EX®105TTM	1	8.	EX-0-325-009	O-Ring (fitted in the TCS plug)	1
1a.	EX-5-303-010	Machine Torch Body FHT-EX®105TTM	1	9.	EX-0-325-005	Male Crimp Pin for TCS Plug	1
1b.	EX-5-304-001	Cap Sensor Replacement Kit with Screws/Machine Torch	1	10.	EX-0-323-001	TCS13 Plug Body	1
1c.	EX-5-306-002	Torch Mounting Sleeve (incl. 3 screws)	1	11.	EX-5-317-021	Machine Torch Strain Relief	1
2.	EX-5-375-011	FHT-EX®105TTM Machine Torch Lead Replacement 5m (16.5')/TCS13	1	12.	EX-5-306-003	Standard Mounting Tube w/o Rack	1
2.	EX-5-375-012	FHT-EX®105TTM Machine Torch Lead Replacement 15m (50')/TCS13	1	13.	EX-5-306-004	Gear Rack	1
2.	EX-5-375-013	FHT-EX®105TTM Machine Torch Lead Replacement 23m (75')/TCS13	1	14.	EX-5-306-009	Short Mounting Tube	1
3.	EX-5-318-001	TCS Plug Spring Strain Relief	1	15.	EX-5-306-005	Standard Mounting Tube Reduction Nut	1
4.	EX-0-325-015	TCS Clam Shell Screw Kit (incl. 4 screws)	1	16.	EX-5-431-050	O-Ring (fitted on the torch body)	1
5.	EX-0-325-002	TCS Clam Shell Upper	1	17.	EX-5-372-005	Torch Mounting Screws Kit (incl. 3 screws)	1
6.	EX-0-325-001	TCS Clam Shell Lower	1	18.	EX-5-372-010	Cathode Mounting Kit	1
7.	EX-0-325-010	Retaining Ring (Outer circlip ring)	1	19.	EX-0-321-003	Latch w/Key Assembly	1

# CONSUMABLES

## STANDARD MACHINE TORCH CONSUMABLES - 45-85 A

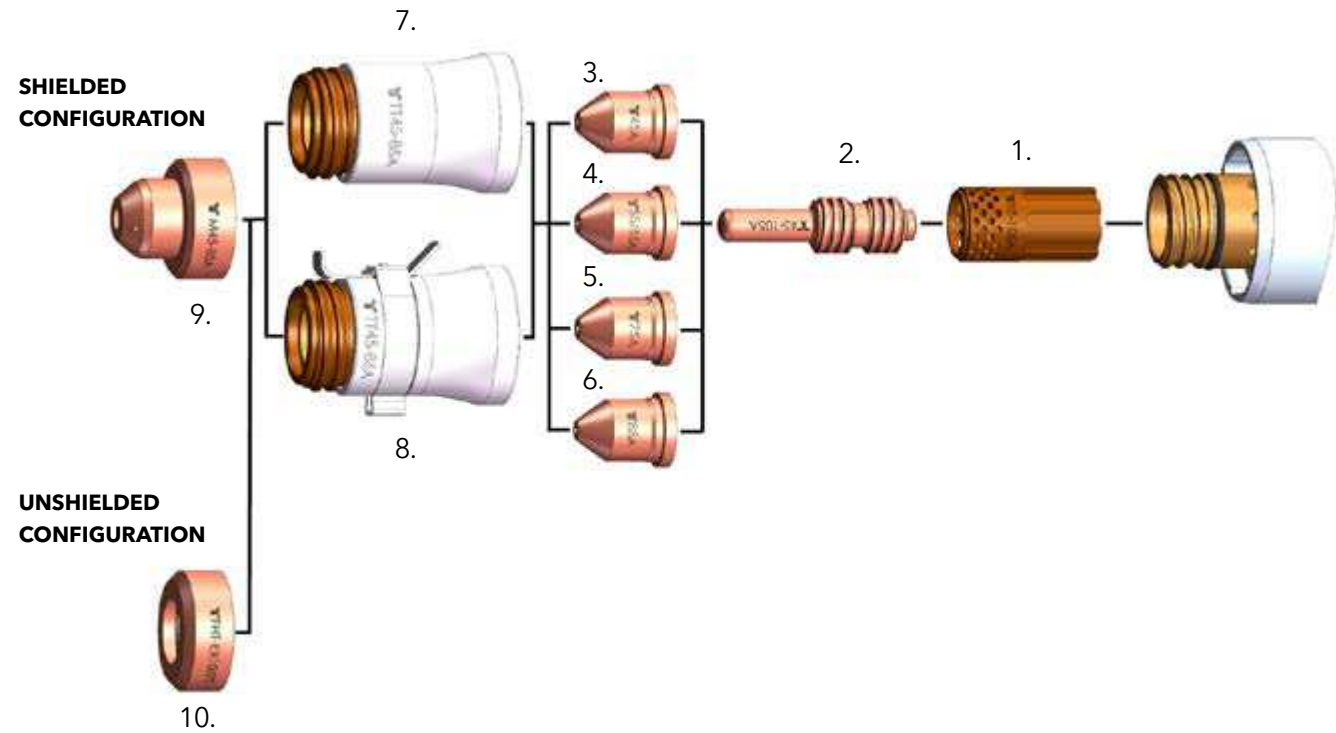

Item	Part No.	Description	Pcs	Item	Part No.	Description	Pcs
1.	EX-5-404-051	Swirl Ring 45-105 A	1	6.	EX-5-410-055	Nozzle 85 A	1
2.	EX-5-401-051	Electrode 45-105 A (pkg.5pcs)	1	7.	EX-5-415-050	Nozzle Retaining Cap 45-85 A	1
3.	EX-5-410-051	Nozzle 45 A	1	8.	EX-5-415-052	Nozzle Retaining Cap 45-85 A w/IHS Tab	1
4.	EX-5-410-053	Nozzle 55/65 A	1	9.	EX-5-422-051	Machine Shield 45-85 A	1
5.	EX-5-410-030	Nozzle 75 A	1	10.	EX-5-423-001	Deflector	1

\* IN COUNTRIES FOLLOWING CE STANDARDS, UNSHIELDED CONSUMABLE CONFIGURATION MAY ONLY BE USED IN MECHANIZED TORCH APPLICATIONS.

# CONSUMABLES

## MACHINE TORCH CONSUMABLES - SMOOTHLINE

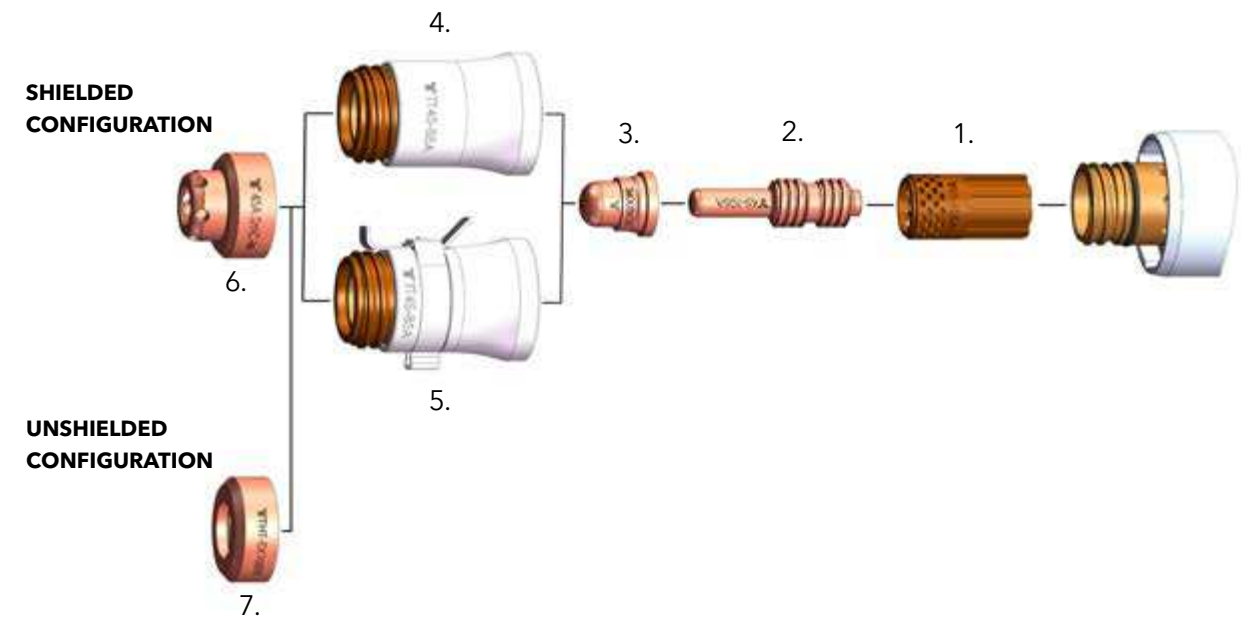

Item	Part No.	Description	Pcs	Item	Part No.	Description	Pcs
1.	EX-5-404-051	Swirl Ring 45-105 A	1	5.	EX-5-415-052	Nozzle Retaining Cap 45-85 A w/IHS Tab	1
2.	EX-5-401-051	Electrode 45-105 A (pkg.5pcs)	1	6.	EX-5-422-050	Machine Shield 40/45 A Smoothline	1
3.	EX-5-410-050	Nozzle Smoothline	1	7.	EX-5-423-001	Deflector	1
4.	EX-5-415-050	Nozzle Retaining Cap 45-85 A	1				

## MACHINE TORCH CONSUMABLES - MARKING

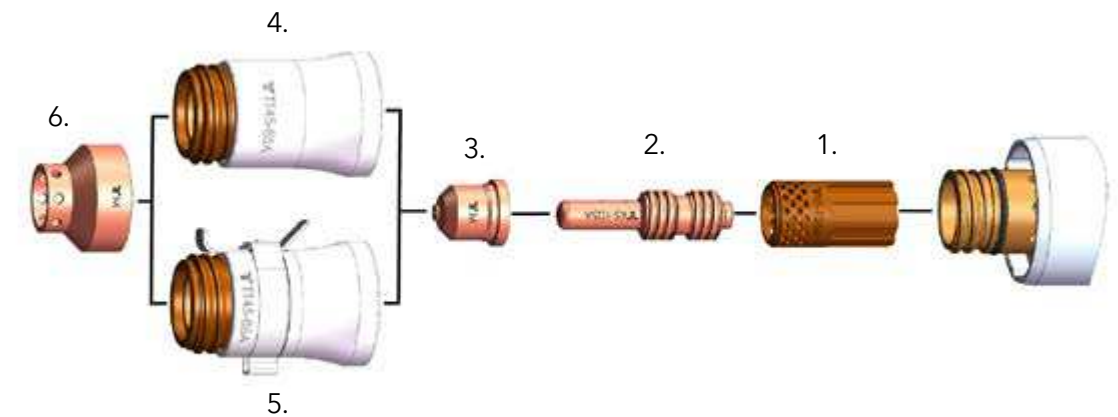

Item	Part No.	Description	Pcs	Item	Part No.	Description	Pcs
1.	EX-5-404-051	Swirl Ring 45-105A	1	4.	EX-5-415-050	Nozzle Retaining Cap 45-85A	1
2.	EX-5-401-051	Electrode 45-105 A (pkg.5pcs)	1	5.	EX-5-415-052	Nozzle Retaining Cap 45-85A w/IHS Tab	1
3.	EX-5-445-001	Marking Nozzle	1	6.	EX-5-445-002	Marking Shield	1

# EX-TRAFIRE® 105HD

**INDUSTRIAL CUTTING.  
HEAVY-DUTY PERFORMANCE.**



SOLUTIONS / INDUSTRIES



Automotive and transportation



Steel mills and steel service centers



Structural



Shipyards and Offshore



Heavy fabrication

# EX-TRAFIRE® 105HD



# EX-TRAFIRE® 105HD

## SPECIFICATIONS

Cutting current	20-105 A
Modes	Cutting / Gouging / Grid / Marking
Duty cycle @ 104 °F	
U1 - 1x 230 VAC	60% - 69A, 100% - 54A
U1 - 3 x 208 VAC	60% - 100A, 100% - 77A
U1 - 3 x 460-575 VAC	80% - 105A, 100% - 94A
Rated output voltage [V] DC	160
Severance cutting capacity*	2 1/4"
Piercing cutting capacity*	3/4"
Recommended cutting capacity*	1 1/2"
Gouging removal	20lbs/hr
Plasma gas	Air / Nitrogen / Argon**
Air flow cut pressure	70 PSI
CAN, RS 485, RS 422	optional
Preadjusted voltage divider ratio***	50:1
Input voltage	1 x 200 - 240 / 3 x 208 - 575 ± 15%
Frequency	50/60 Hz
Dimensions LxWxH [inch]	24" x 12" x 20"
Weight [lbs]	96 lbs
Certification depending on region	CSA
Recommended Min/Max Pressure	90-145 PSI
Protection level	IP23S
Insulation class	F
Type of hand torch	FHT-EX®105TTH
Type of machine torch	FHT-EX®105TTM

\*values for low alloy steel, e. g. MS S235JR  
 \*\*used for optional fine marking  
 \*\*\*part of optional CNC interface  
 \*\*\*\* I2 reduced to 85A at single pahse inputvoltage

## IMPRESSIVE PERFORMANCE



- + Industry leading high cutting speed
- + Maximum cutting quality, even with long cuts
- + Also ideal for automated processes

## READY FOR INDUSTRY 4.0



- + Industry leading connectivity
- + CAN, RS 485 and RS 422 interfaces (optional)
- + Easy monitoring
- + Expandable and updatable

## HIGHEST FLEXIBILITY



- + Plate thicknesses up to 2 1/4 inches
- + For mechanized and manual applications
- + Gouging with high removal rate
- + Suitable for worldwide use

## MARKING MODE

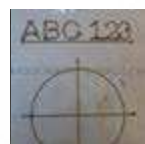

- + Automatic gas identification (air, nitrogen, argon)
- + Integrated gas saving function
- + Fine, deep or wide markings
- + Optional smooth marking for applications below 20A

## AUTOMATIC SETTINGS



- + Automated settings for cutting parameters
- + Compensation for pressure drops
- + Fewer operating errors, better cutting quality

## NEW CUTTING TORCH FHT® EX105TT



- + Torch design award winner
- + Optimized ergonomics
- + Relaxed PE and PA cutting
- + 100% duty cycle

## 4 DIFFERENT OPERATION MODES

The plasma cutting systems in the EX-TRAFIRE®HD range excel at meeting demanding requirements during continuous operation. The portable EX-TRAFIRE®105HD plasma cutting system, with a 100% duty cycle, is the perfect solution for challenging heavy-duty industrial applications.



# EX-TRAFIRE® 105HD

## ORDERING INFORMATION

Description	Length	Part No.
<b>MANUAL PLASMA CUTTING SYSTEMS</b>		
EX-TRAFIRE®105HD/CSA/200-600V 3-PH Hand System/FHT-EX®105TTH Torch 16.4 ft/H Starter Kit	16.4 ft	EX-5-010-051
EX-TRAFIRE®105HD/CSA/200-600V 3-PH Hand System/FHT-EX®105TTH Torch 26.2 ft/H Starter Kit	26.2 ft	EX-5-010-052
EX-TRAFIRE®105HD/CSA/200-600V 3-PH Hand System/FHT-EX®105TTH Torch 49.2 ft/H Starter Kit	49.2 ft	EX-5-010-053
<b>MECHANIZED PLASMA CUTTING SYSTEMS</b>		
EX-TRAFIRE®105HD/CSA/200-600V 3-PH Machine System/FULLY EQUIPPED/FHT-EX®105TTM STD-NR Torch 26.2 ft/M Starter Kit	26.2 ft	EX-5-011-036
EX-TRAFIRE®105HD/CSA/200-600V 3-PH Machine System/FULLY EQUIPPED/FHT-EX®105TTM STD-NR Torch 49.2 ft/M Starter Kit	49.2 ft	EX-5-011-037
EX-TRAFIRE®105HD/CSA/200-600V 3-PH Machine System/STD EQUIPPED/FHT-EX®105TTM STD-NR Torch 26.2 ft/M Starter Kit	26.2 ft	EX-5-013-014
EX-TRAFIRE®105HD/CSA/200-600V 3-PH Machine System/STD EQUIPPED/FHT-EX®105TTM STD-NR Torch 49.2 ft/M Starter Kit	49.2 ft	EX-5-013-015

### PLASMA CUTTING UNITS

EX-TRAFIRE® 105HD/CSA/200-600V 3-PH power supply unit/FULLY EQUIPPED	EX-5-001-005
EX-TRAFIRE® 105HD/CSA/200-600V 3-PH power supply unit/STD EQUIPPED	EX-5-003-005

\* Fully-equipped=CNC interface & Serial interfaceport (CAN bus)  
 \*\* STD-equipped=CNC interface

## ACCESSORIES

Description	Pcs	Part No.
CNC Interface 14-pin Plug Kit	1	EX-0-803-001
CNC Interface connection lead 9.8 ft	1	EX-0-803-003
CNC Interface connection lead 19.6 ft	1	EX-0-803-004
CAN bus connection cable 32.8 ft	1	EX-0-803-006
CAN bus connection cable 16.4 ft	1	EX-0-803-007
RS422 bus connection cable 32.8 ft	1	EX-0-803-008
RS422 bus connection cable 16.4 ft	1	EX-0-803-009
Universal connection cable 32.8 ft	1	EX-0-803-010
Universal connection cable 16.4 ft	1	EX-0-803-011
Silicone Grease .8 oz	1	EX-0-805-001
Work lead with clamp 300 A/13.1 ft/6 AWG/EU-plug 2-2/0 AWG	1	EX-5-543-037
Work lead with clamp 300 A/26.2 ft//6 AWG/EU-plug 2-2/0 AWG (ON REQUEST)	1	EX-5-543-001
Work lead with clamp 300 A/49.2 ft/6 AWG/EU-plug 2-2/0 AWG (ON REQUEST)	1	EX-5-543-002
Work lead with clamp 300 A/75.4 ft/6 AWG/EU-plug 2-2/0 AWG (ON REQUEST)	1	EX-5-543-003

# EX-TRAFIRE® 105HD



FRONT VIEW



BACK VIEW



SIDE VIEW

# FHT-EX® 105TT



# FHT-EX® 105TTH

## HAND TORCH ASSEMBLY



Item	Part No.	Description	Pcs
1.	EX-5-139-001	FHT-EX®105TTH Hand Torch Assembly-w/o consumables w/5m (16.5') Lead/TCS13	1
	EX-5-139-002	FHT-EX®105TTH Hand Torch Assembly w/o consumables w/8m (26') Lead/TCS13	1
	EX-5-139-003	FHT-EX®105TTH Hand Torch Assembly w/o consumables w/15m (50') Lead/TCS13	1
	EX-5-139-004	FHT-EX®105TTH Hand Torch Assembly w/o consumables w/23m (75') Lead/TCS13	1
2.	EX-0-321-003	Latch with Key Assembly	1

⊕ LATCH WITH KEY IS NOT CONTENT OF TORCHES ABOVE. IF YOU NEED IT, YOU HAVE TO ORDER SEPARATELY.



The high-performing FHT-EX®105TT H/M hand and machine torches meet the tough demands of continuous operations. Designed for optimal use with 105HD power supply for cutting, gouging, grid-cutting and marking, while allowing cut thickness up to 2 1/4 inches with greater precision and speed.

With the Thermacut® Torch Connection System (TCS), changing the torch is a quick and easy process. Resulting from decades of experience in the field of plasma cutting, the power supplies features an extremely robust and durable design supported by consumables that can be replaced quick and easily.

### BENEFITS

- High-performance torches for mechanized applications and handheld use
- Ergonomic handheld torches that increase time cutting safely in all positions
- Compact and flexible for handheld applications, even with tight radius or the gouging of fillet welds
- 100 % duty cycle at 94A for continuous use
- Capable of plate thicknesses up to 2 1/4 inches
- Extended life consumables
- Quick and tool-free replacement of consumables
- Piercing capability up to 3/4 of an inch

# FHT-EX® 105TTH

## HAND TORCH COMPONENTS

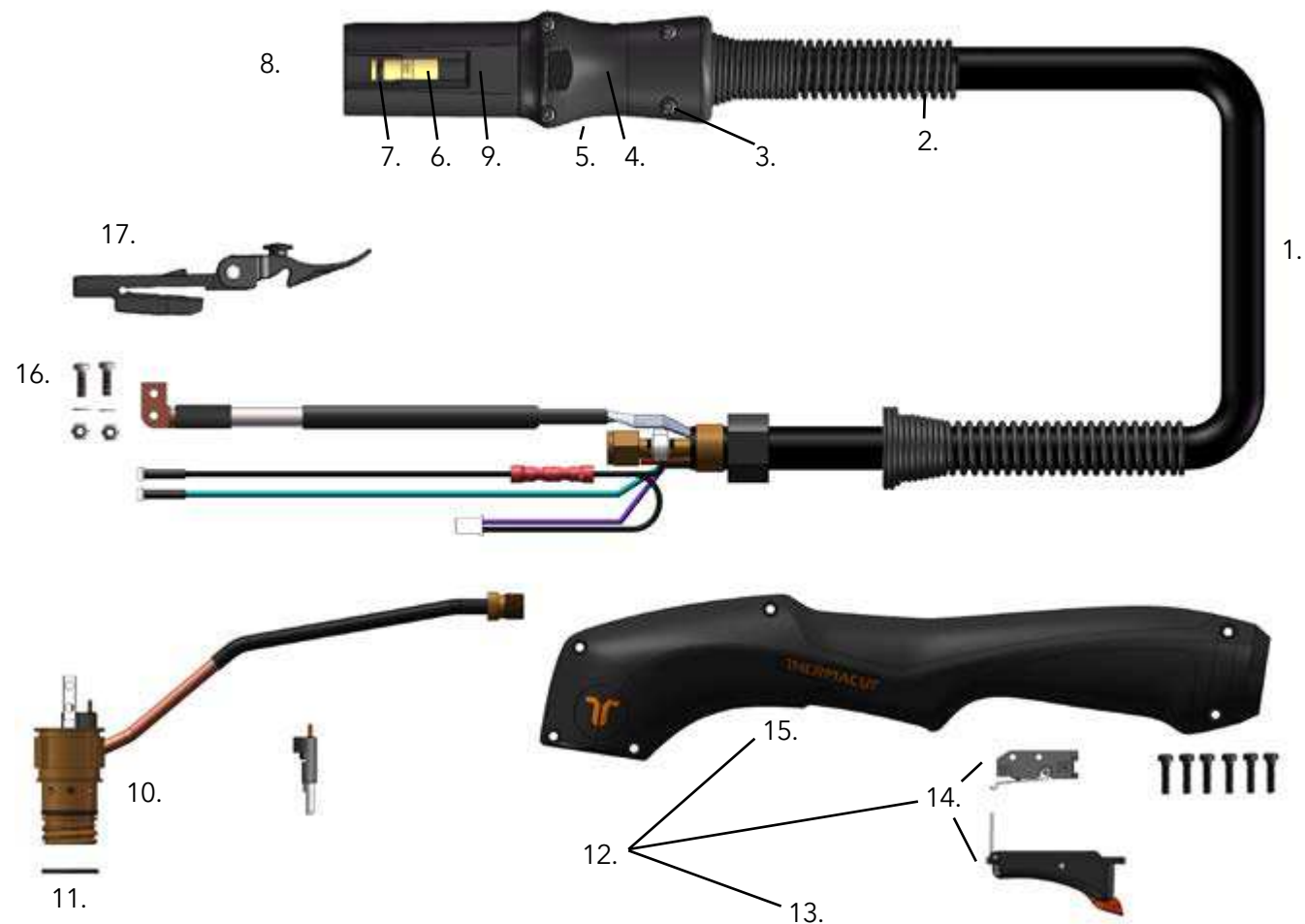

Item	Part No.	Description	Pcs	Item	Part No.	Description	Pcs
1.	EX-5-374-010	FHT-EX®105TTH Hand Torch Lead Replacement 5m (16.5')/TCS13	1	8.	EX-0-325-005	Male Crimp Pin for TCS Plug	1
1.	EX-5-374-011	FHT-EX®105TTH Hand Torch Lead Replacement 8m (26')/TCS13	1	9.	EX-0-323-001	TCS13 Plug Body	1
1.	EX-5-374-012	FHT-EX®105TTH Hand Torch Lead Replacement 15m (50')/TCS13	1	10.	EX-5-302-001	Hand Torch Body Repl. Kit (incl. Torch body & Cap sensor)	2
1.	EX-5-374-013	FHT-EX®105TTH Hand Torch Lead Replacement 23m (75')/TCS13	1	11.	EX-5-431-050	O-Ring (fitted on the torch body) - 2 pcs	1
2.	EX-5-318-001	TCS Plug Spring Strain Relief	1	12.	EX-5-314-001	Hand Torch Handle Replacement Kit	1
3.	EX-0-325-015	TCS Clam Shell Screw Kit (incl. 4 screws)	1	13.	EX-5-305-002	Cap-sensor Replacement Kit with Screws/ Hand Torch	1
4.	EX-0-325-002	TCS Clam Shell Upper	1	14.	EX-5-313-031	Safety Trigger	1
5.	EX-0-325-001	TCS Clam Shell Lower	1	15.	EX-5-308-001	Hand Torch Handle with Screws	1
6.	EX-0-325-010	Retaining Ring (Outer circlip ring)	1	16.	EX-5-372-010	Cathode mounting kit	1
7.	EX-0-325-009	O-Ring (fitted in the TCS plug)	1	17.	EX-0-321-003	Latch w/Key Assembly	1
				18.	EX-5-313-030	Safety Trigger Micro-Switch	

# CONSUMABLES

## HAND TORCH CONSUMABLES - 45-85 A

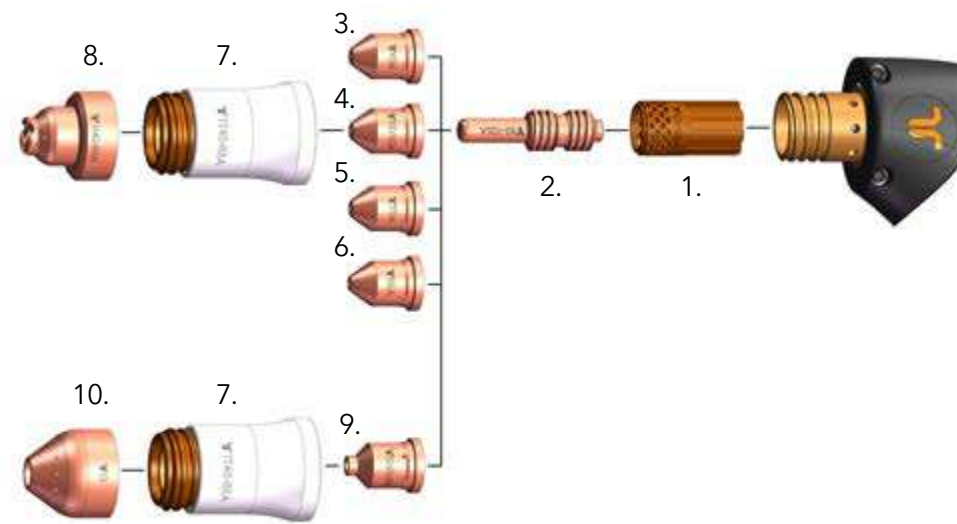

Item	Part No.	Description	Pcs	Item	Part No.	Description	Pcs
1.	EX-5-404-051	Swirl Ring 45-105 A	1	6.	EX-5-410-055	Nozzle 85 A	1
2.	EX-5-401-051	Electrode 45-105 A (pkg.5pcs)	1	7.	EX-5-415-050	Nozzle Retaining Cap 45-85 A	1
3.	EX-5-410-051	Nozzle 45 A	1	8.	EX-5-422-031	Hand Shield 45-85 A	1
4.	EX-5-410-053	Nozzle 55/65 A	1	9.	EX-5-440-051	Gouging Nozzle 45-85 A	1
5.	EX-5-410-030	Nozzle 75 A	1	10.	EX-5-440-050	Gouging Shield	1

## HAND TORCH CONSUMABLES - 100-105 A

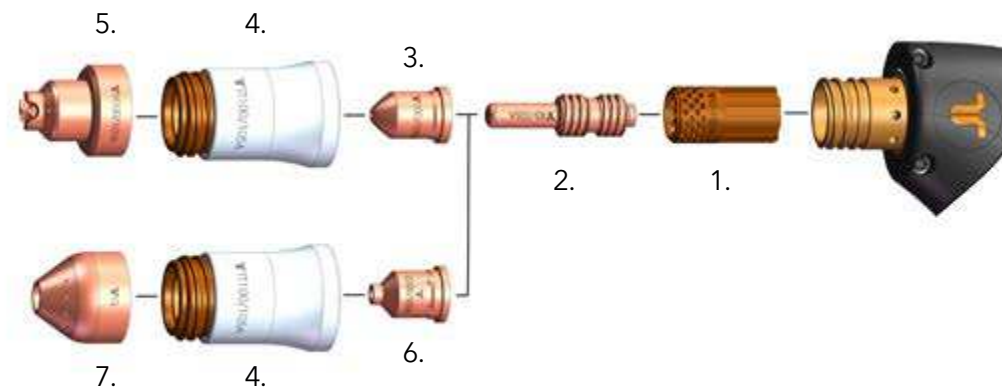

Item	Part No.	Description	Pcs	Item	Part No.	Description	Pcs
1.	EX-5-404-051	Swirl Ring 45-105 A	1	5.	EX-5-422-032	Hand Shield 100/105 A	1
2.	EX-5-401-051	Electrode 45-105 A (pkg.5pcs)	1	6.	EX-5-440-052	Gouging Nozzle 100/105 A	1
3.	EX-5-410-056	Nozzle 100/105 A	1	7.	EX-5-440-050	Gouging Shield	1
4.	EX-5-415-051	Nozzle Retaining Cap 100/105 A	1				

# CONSUMABLES

# FHT-EX® 105TTM

## HAND TORCH CONSUMABLES - SMOOTHLINE

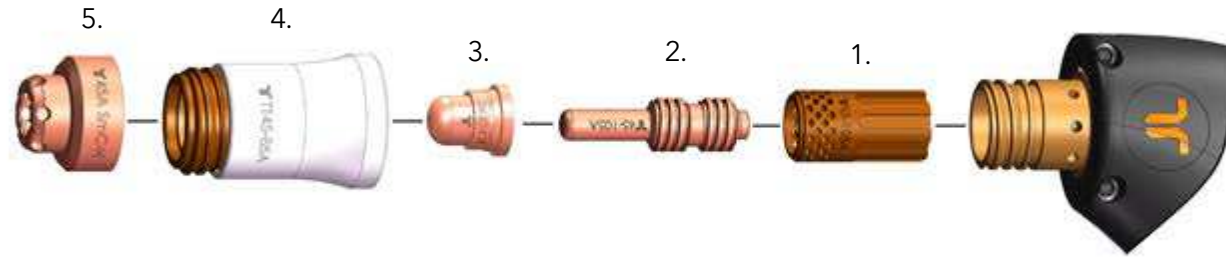

Item	Part No.	Description	Pcs
1.	EX-5-404-051	Swirl Ring 45-105 A	1
2.	EX-5-401-051	Electrode 45-105 A (pkg. 5pcs)	1
3.	EX-5-410-050	Nozzle Smoothline	1
4.	EX-5-415-050	Nozzle Retaining Cap 45-85 A	1
5.	EX-5-420-050	Hand Shield 40/45 A Smoothline	1

## MACHINE TORCH ASSEMBLY

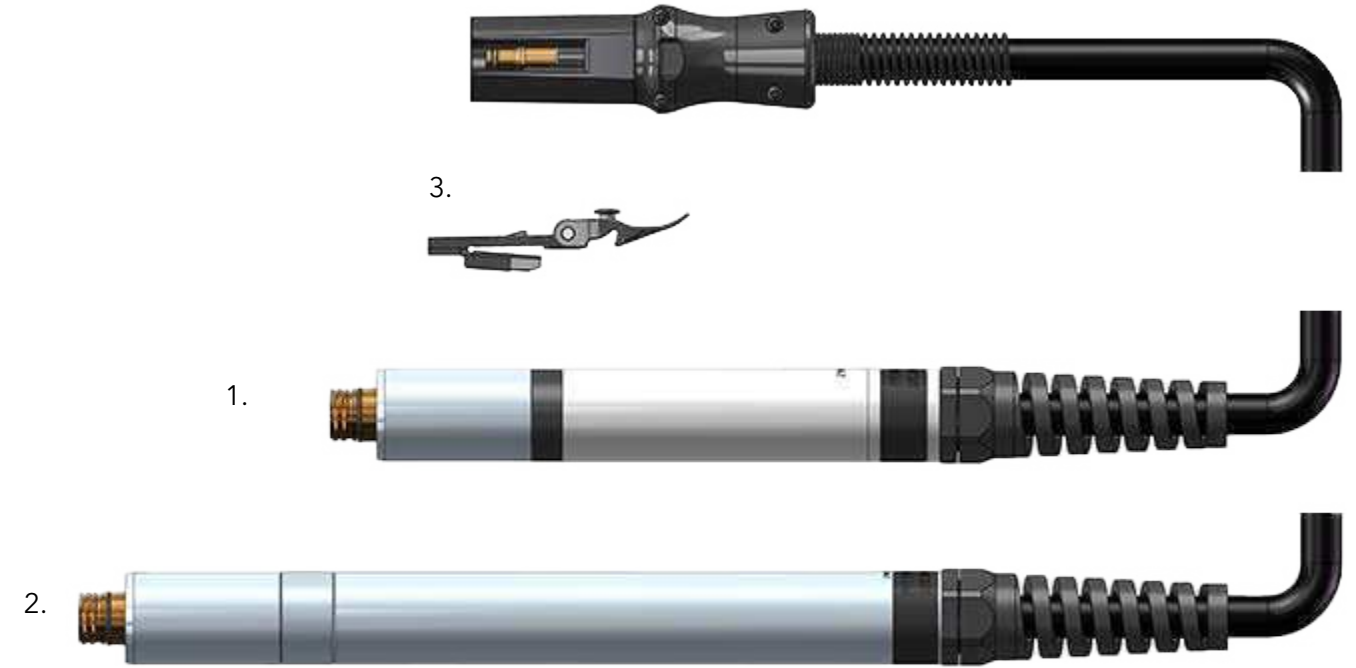

Item	Part No.	Description	Pcs
NS	EX-5-242-021	DEMO FHT-EX® 105TTSM Short Machine Torch Assembly/ TCS13	1
1.	EX-5-242-021	FHT-EX® 105TTSM Short Machine Torch Assembly-w/o consumables w/5m (16.5') Lead/ TCS13	1
1.	EX-5-244-021	FHT-EX® 105TTSM Short Machine Torch Assembly-w/o consumables w/8m (26') Lead/ TCS13	1
1.	EX-5-247-021	FHT-EX® 105TTSM Short Machine Torch Assembly-w/o consumables w/15m (50') Lead/ TCS13	1
1.	EX-5-250-021	FHT-EX® 105TTSM Short Machine Torch Assembly-w/o consumables w/23m (75') Lead/ TCS13	1
2.	EX-5-202-031	FHT-EX® 105TTM M Torch w/o Rack Assy w/o consumables w/5m (16.5')Lead/ TCS13	1
2.	EX-5-204-031	FHT-EX® 105TTM M Torch w/o Rack Assy w/o consumables w/8m (26') Lead/ TCS13	1
2.	EX-5-207-032	FHT-EX® 105TTM M Torch w/o Rack Assy w/o consumables w/15m (50') Lead/ TCS13	1
2.	EX-5-210-034	FHT-EX® 105TTM M Torch w/o Rack Assy w/o consumables w/23m (75') Lead/ TCS13	1
3.	EX-0-321-003	Latch with Key Assembly	1

3. LATCH WITH KEY IS NOT CONTENT OF TORCHES ABOVE. IF YOU NEED IT, YOU HAVE TO ORDER SEPARATELY.



# FHT-EX® 105TTM

## MACHINE TORCH COMPONENTS



Item	Part No.	Description	Pcs	Item	Part No.	Description	Pcs
1.	EX-5-303-011	Machine Torch Body Assembly FHT-EX®105TTM	1	8.	EX-0-325-009	O-Ring (fitted in the TCS plug)	1
1a.	EX-5-303-010	Machine Torch Body FHT-EX®105TTM	1	9.	EX-0-325-005	Male Crimp Pin for TCS Plug	1
1b.	EX-5-304-001	Cap Sensor Replacement Kit with Screws/Machine Torch	1	10.	EX-0-323-001	TCS13 Plug Body	1
1c.	EX-5-306-002	Torch Mounting Sleeve (incl. 3 screws)	1	11.	EX-5-317-021	Machine Torch Strain Relief	1
2.	EX-5-375-010	FHT-EX®105TTM Machine Torch Lead Replacement 5m (16.5')/TCS13	1	12.	EX-5-306-003	Standard Mounting Tube w/o Rack	1
2.	EX-5-375-011	FHT-EX®105TTM Machine Torch Lead Replacement 8m (26')/TCS13	1	13.	EX-5-306-004	Gear Rack	1
2.	EX-5-375-012	FHT-EX®105TTM Machine Torch Lead Replacement 15m (50')/TCS13	1	14.	EX-5-306-009	Short Mounting Tube	1
2.	EX-5-375-013	FHT-EX®105TTM Machine Torch Lead Replacement 23m (75')/TCS13	1	15.	EX-5-306-005	Standard Mounting Tube Reduction Nut	1
3.	EX-5-318-001	TCS Plug Spring Strain Relief	1	16.	EX-5-431-050	O-Ring (fitted on the torch body)	1
4.	EX-0-325-015	TCS Clam Shell Screw Kit (incl. 4 screws)	1	17.	EX-5-372-005	Torch Mounting Screws Kit (incl. 3 screws)	1
5.	EX-0-325-002	TCS Clam Shell Upper	1	18.	EX-5-372-010	Catode Mounting Kit	1
6.	EX-0-325-001	TCS Clam Shell Lower	1	19.	EX-0-321-003	Latch w/Key Assembly	1
7.	EX-0-325-010	Retaining Ring (Outer circlip ring)	1				

# CONSUMABLES

## STANDARD MACHINE TORCH CONSUMABLES - 45-85 A

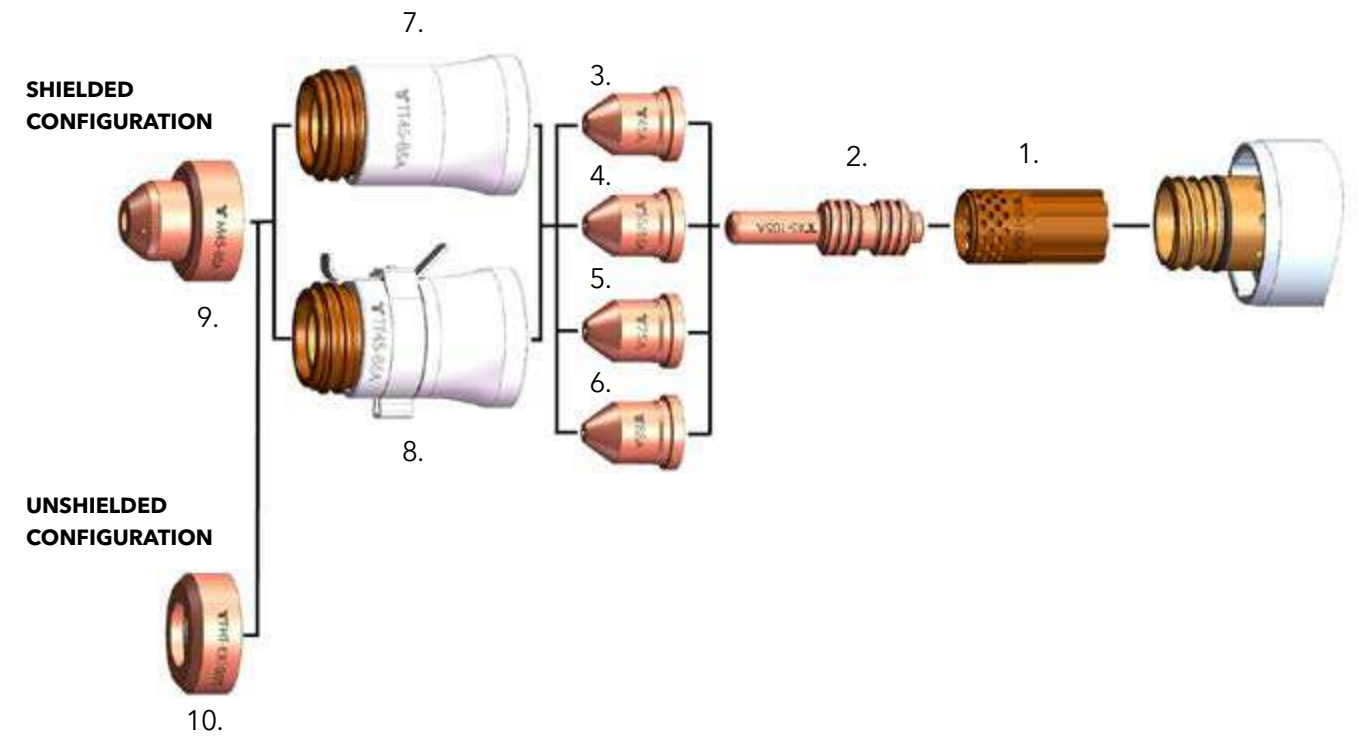

Item	Part No.	Description	Pcs	Item	Part No.	Description	Pcs
1.	EX-5-404-051	Swirl Ring 45-105 A	1	6.	EX-5-410-055	Nozzle 85 A	1
2.	EX-5-401-051	Electrode 45-105 A (pkg.5pcs)	1	7.	EX-5-415-050	Nozzle Retaining Cap 45-85 A	1
3.	EX-5-410-051	Nozzle 45 A	1	8.	EX-5-415-052	Nozzle Retaining Cap 45-85 A w/lhs Tab	1
4.	EX-5-410-053	Nozzle 55/65 A	1	9.	EX-5-422-051	Machine Shield 45-85 A	1
5.	EX-5-410-030	Nozzle 75 A	1	10.	EX-5-423-001	Deflector	1

\* IN COUNTRIES FOLLOWING CE STANDARDS, UNSHIELDED CONSUMABLE CONFIGURATION MAY ONLY BE USED IN MECHANIZED TORCH APPLICATIONS.

# CONSUMABLES

## MACHINE TORCH CONSUMABLES - 100-105 A

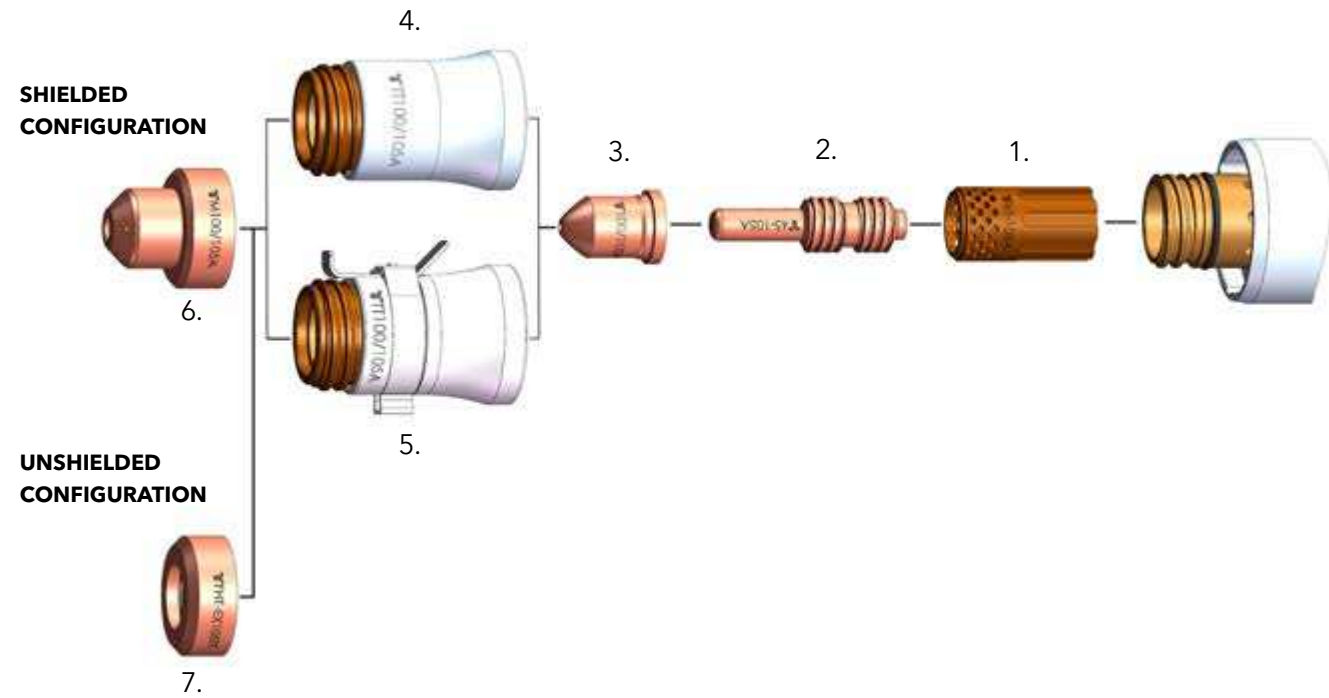

Item	Part No.	Description	Pcs
1.	EX-5-404-051	Swirl Ring 45-105 A	1
2.	EX-5-401-051	Electrode 45-105 A (pkg. 5pcs)	1
3.	EX-5-410-056	Nozzle 100/105 A	1
4.	EX-5-415-051	Nozzle Retaining Cap 100/105 A	1
5.	EX-5-415-053	Nozzle Retaining Cap 100/105 A w/IHS Tab	1
6.	EX-5-422-052	Machine Shield 100/105 A	1
7.	EX-5-423-001	Deflector	1

# CONSUMABLES

## MACHINE TORCH CONSUMABLES - SMOOTHLINE

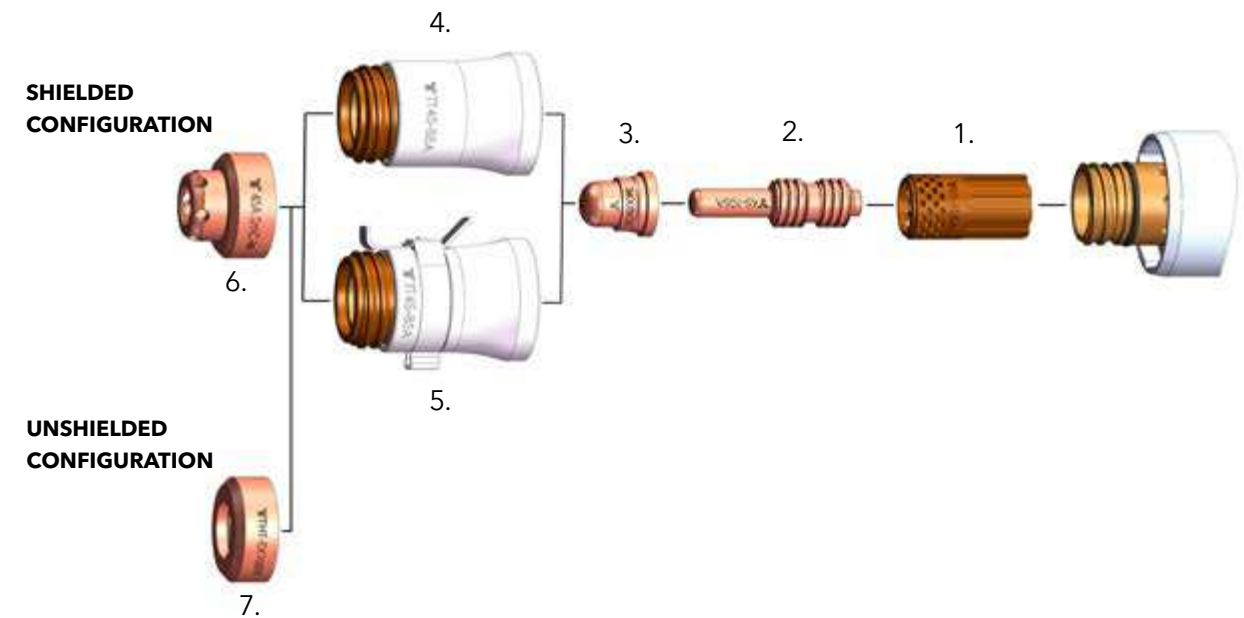

Item	Part No.	Description	Pcs	Item	Part No.	Description	Pcs
1.	EX-5-404-051	Swirl Ring 45-105 A	1	5.	EX-5-415-052	Nozzle Retaining Cap 45-85 A w/IHS Tab	1
2.	EX-5-401-051	Electrode 45-105 A (pkg. 5pcs)	1	6.	EX-5-422-050	Machine Shield 40/45 A Smoothline	1
3.	EX-5-410-050	Nozzle Smoothline	1	7.	EX-5-423-001	Deflector	1
4.	EX-5-415-050	Nozzle Retaining Cap 45-85 A	1				

## MACHINE TORCH CONSUMABLES - MARKING

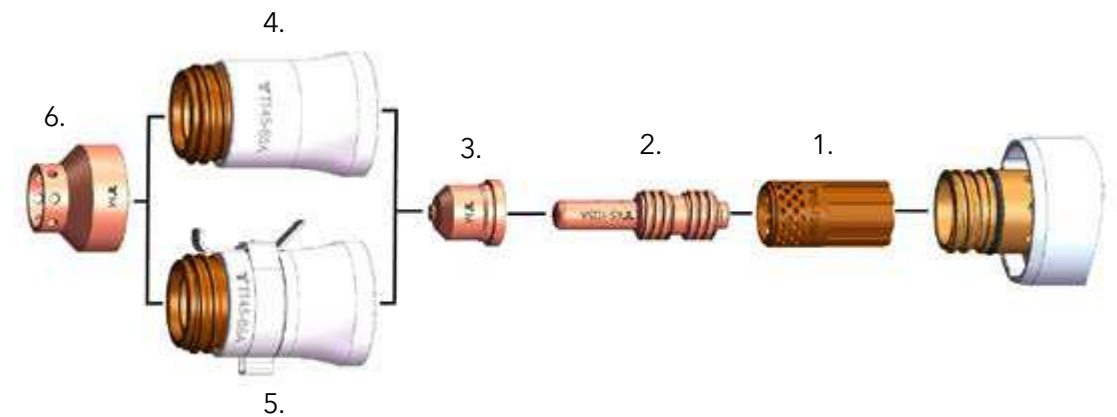

Item	Part No.	Description	Pcs	Item	Part No.	Description	Pcs
1.	EX-5-404-051	Swirl Ring 45-105A	1	4.	EX-5-415-050	Nozzle Retaining Cap 45-85A	1
2.	EX-5-401-051	Electrode 45-105 A (pkg. 5pcs)	1	5.	EX-5-415-052	Nozzle Retaining Cap 45-85A w/IHS Tab	1
3.	EX-5-445-001	Marking Nozzle	1	6.	EX-5-445-002	Marking Shield	1

# EX-TRAFIRE® I25HD

## INDUSTRIAL CUTTING. HEAVY-DUTY PERFORMANCE.

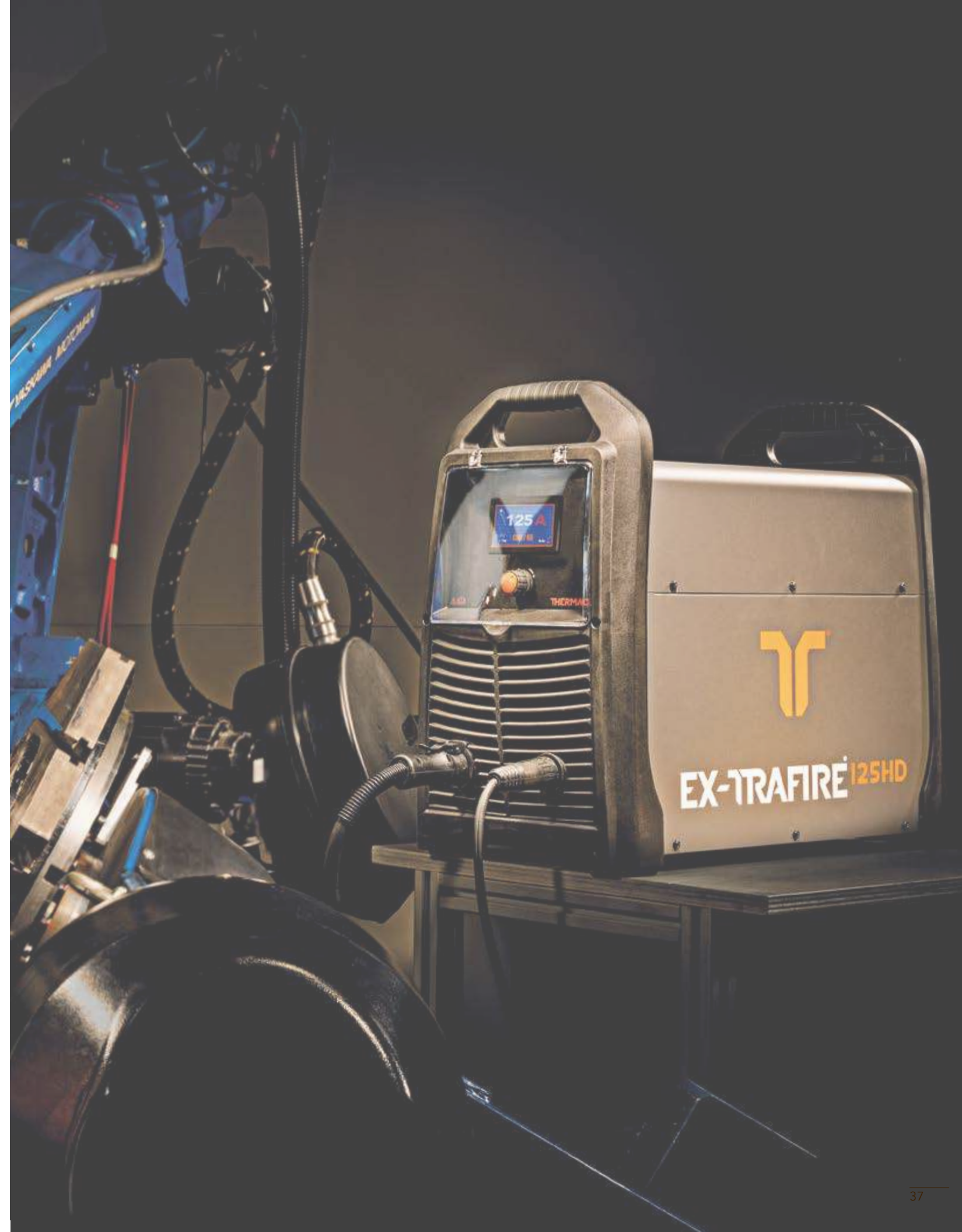

### SOLUTIONS / INDUSTRIES



Automotive and transportation



Steel mills and steel service centers



Structural



Shipyards and Offshore



Heavy fabrication

# EX-TRAFIRE® 125HD



CUTTING  
**125 A**  
CURRENT

MATERIAL  
**2 1/2 inches**  
THICKNESS

VARIOUS  
OPERATION  
MODES

## IMPRESSIVE PERFORMANCE



- + Industry leading high cutting speed
- + Maximum cutting quality, even with long cuts
- + Also ideal for automated processes

## READY FOR INDUSTRY 4.0



- + Industry leading connectivity
- + CAN, RS 485 and RS 422 interfaces (optional)
- + Easy monitoring
- + Expandable and updatable

## HIGHEST FLEXIBILITY



- + Plate thicknesses up to 2 3/8 inches
- + For mechanized and manual applications
- + Gouging with high removal rate
- + Suitable for worldwide use

## MARKING MODE

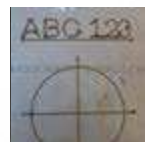

- + Automatic gas identification (air, nitrogen, argon)
- + Integrated gas saving function
- + Fine, deep or wide markings
- + Optional smooth marking for applications below 20A

## AUTOMATIC SETTINGS



- + Automated settings for cutting parameters
- + Compensation for pressure drops
- + Fewer operating errors, better cutting quality

## NEW CUTTING TORCH FHT® EX125TT



- + Torch design award winner
- + Optimized ergonomics
- + Relaxed PE and PA cutting
- + 100% duty cycle

# EX-TRAFIRE® 125HD

## SPECIFICATIONS

Cutting current	30 - 125 A
Modes	Cutting / Gouging / Grid / Marking
Duty cycle @ 104 °F	100 % @ 125 A
Rated output voltage [V] DC	180
Severance cutting capacity*	2 - 1/2"
Piercing cutting capacity*	1"
Recommended cutting capacity*	1 - 1/2"
Gouging removal	17.6 lbs/hr
Plasma gas	Air / Nitrogen / Argon**
Air flow cut pressure	75 PSI
CAN, RS 485, RS 422	optional
Preadjusted voltage divider ratio***	50:1
Input voltage	3 x 480 or 3 x 575 ± 15%
Frequency	50 / 60 Hz
Dimensions LxWxH [inch]	24" x 12" x 21"
Weight	75 lbs
Certification depending on region	CSA
Recommended Min/Max pressure	90-145 PSI
Protection level	IP23S
Insulation class	F
Type of hand torch	FHT-EX®125TTH
Type of machine torch	FHT-EX®125TTM

\*values for low alloy steel, e. g. MS S235JR  
 \*\*10A with optional Finmarking upgrade  
 \*\*\* when equipped with optional CNC interface

## 4 DIFFERENT OPERATION MODES

The plasma cutting systems in the EX-TRAFIRE®HD range excel at meeting demanding requirements during continuous operation. The powerful EX-TRAFIRE®125HD plasma cutting system, with a 100% duty cycle, is the perfect solution for challenging heavy-duty industrial applications.

CUTTING

GRID CUTTING

MARKING

GOUGING

# EX-TRAFIRE® 125HD

## ORDERING INFORMATION

Description	Length	Part No.
<b>MANUAL PLASMA CUTTING SYSTEMS</b>		
EX-TRAFIRE®125HD/CSA/3x440-480V Hand System/FHT-EX®125TTH Torch 26.2 ft/H Starter Kit	26.2 ft	EX-6-010-007
EX-TRAFIRE®125HD/CSA/3x380V Hand System/FHT-EX®125TTH Torch 26.2 ft/H Starter Kit	26.2 ft	EX-6-010-009
EX-TRAFIRE®125HD/CSA/3x380V Hand System/FHT-EX®125TTH Torch 49.2 ft /H Starter Kit	49.2 ft	EX-6-010-010
EX-TRAFIRE®125HD/CSA/3x575/600V Hand System/FHT-EX®125TTH Torch 26.2 ft/H Starter Kit	26.2 ft	EX-6-010-011
EX-TRAFIRE®125HD/CSA/3x575/600V Hand System/FHT-EX®125TTH Torch 49.2 ft /H Starter Kit	49.2 ft	EX-6-010-012
EX-TRAFIRE®125HD/CSA/3x440-480V Hand System/FHT-EX®125TTH Torch 49.2 ft /H Starter Kit	49.2 ft	EX-6-010-008
<b>MECHANIZED PLASMA CUTTING SYSTEMS</b>		
EX-TRAFIRE®125HD/CSA/3x440-480V Machine System/FULLY EQUIPPED/FHT-EX®125TTM Torch 26.2 ft/H Starter Kit	26.2 ft	EX-6-011-007
EX-TRAFIRE®125HD/CSA/3x440-480V Machine System/FULLY EQUIPPED/FHT-EX®125TTM Torch 49.2 ft/H Starter Kit	49.2 ft	EX-6-011-008
EX-TRAFIRE®125HD/CSA/3x440-480V Machine System/STD EQUIPPED/FHT-EX®125TTM Torch 26.2 ft/H Starter Kit	26.2 ft	EX-6-013-001
EX-TRAFIRE®125HD/CSA/3x440-480V Machine System/STD EQUIPPED/FHT-EX®125TTM Torch 49.2 ft/H Starter Kit	49.2 ft	EX-6-013-002
EX-TRAFIRE®125HD/CSA/3x575/600V Machine System/FULLY EQUIPPED/FHT-EX®125TTM Torch 26.2 ft/H Starter Kit	26.2 ft	EX-6-011-011
EX-TRAFIRE®125HD/CSA/3x575/600V Machine System/FULLY EQUIPPED/FHT-EX®125TTM Torch 49.2 ft/H Starter Kit	49.2 ft	EX-6-011-012
EX-TRAFIRE®125HD/CSA/3x575/600V Machine System/STD EQUIPPED/FHT-EX®125TTM Torch 26.2 ft/H Starter Kit	26.2 ft	EX-6-013-003
EX-TRAFIRE®125HD/CSA/3x575/600V Machine System/STD EQUIPPED/FHT-EX®125TTM Torch 49.2 ft/H Starter Kit	49.2 ft	EX-6-013-004
EX-TRAFIRE®125HD/CSA/3x380V Machine System/STD EQUIPPED/FHT-EX®125TTM Torch 26.2 ft/H Starter Kit	26.2 ft	EX-6-011-009
EX-TRAFIRE®125HD/CSA/3x380V Machine System/STD EQUIPPED/FHT-EX®125TTM Torch 49.2 ft/H Starter Kit	49.2 ft	EX-6-011-010

## ACCESSORIES

Description	Pcs	Part No.
CNC Interface 14-pin Plug Kit	1	EX-0-803-001
CNC Interface connection lead 9.8 ft	1	EX-0-803-003
CNC Interface connection lead 19.6 ft	1	EX-0-803-004
CAN bus connection cable 32.8 ft	1	EX-0-803-006
CAN bus connection cable 16.4 ft	1	EX-0-803-007
RS422 bus connection cable 32.8 ft	1	EX-0-803-008
RS422 bus connection cable 16.4 ft	1	EX-0-803-009
Universal connection cable 32.8 ft	1	EX-0-803-010
Universal connection cable 16.4 ft	1	EX-0-803-011
Silicone Grease .8 oz	1	EX-0-805-001
Work lead with clamp 300 A/13.1 ft/6 AWG/EU-plug 2-2/0 AWG	1	EX-5-543-037
Work lead with clamp 300 A/26.2 ft/6 AWG/EU-plug 2-2/0 AWG (ON REQUEST)	1	EX-5-543-001
Work lead with clamp 300 A/49.2 ft/6 AWG/EU-plug 2-2/0 AWG (ON REQUEST)	1	EX-5-543-002
Work lead with clamp 300 A/75.4 ft/6 AWG/EU-plug 2-2/0 AWG (ON REQUEST)	1	EX-5-543-003

# EX-TRAFIRE® 125HD



FRONT VIEW



BACK VIEW



SIDE VIEW

# FHT-EX® 125TT

## HAND / MACHINE TORCHES AND CONSUMABLES

SUITABLE FOR EX-TRAFIRE® 125HD

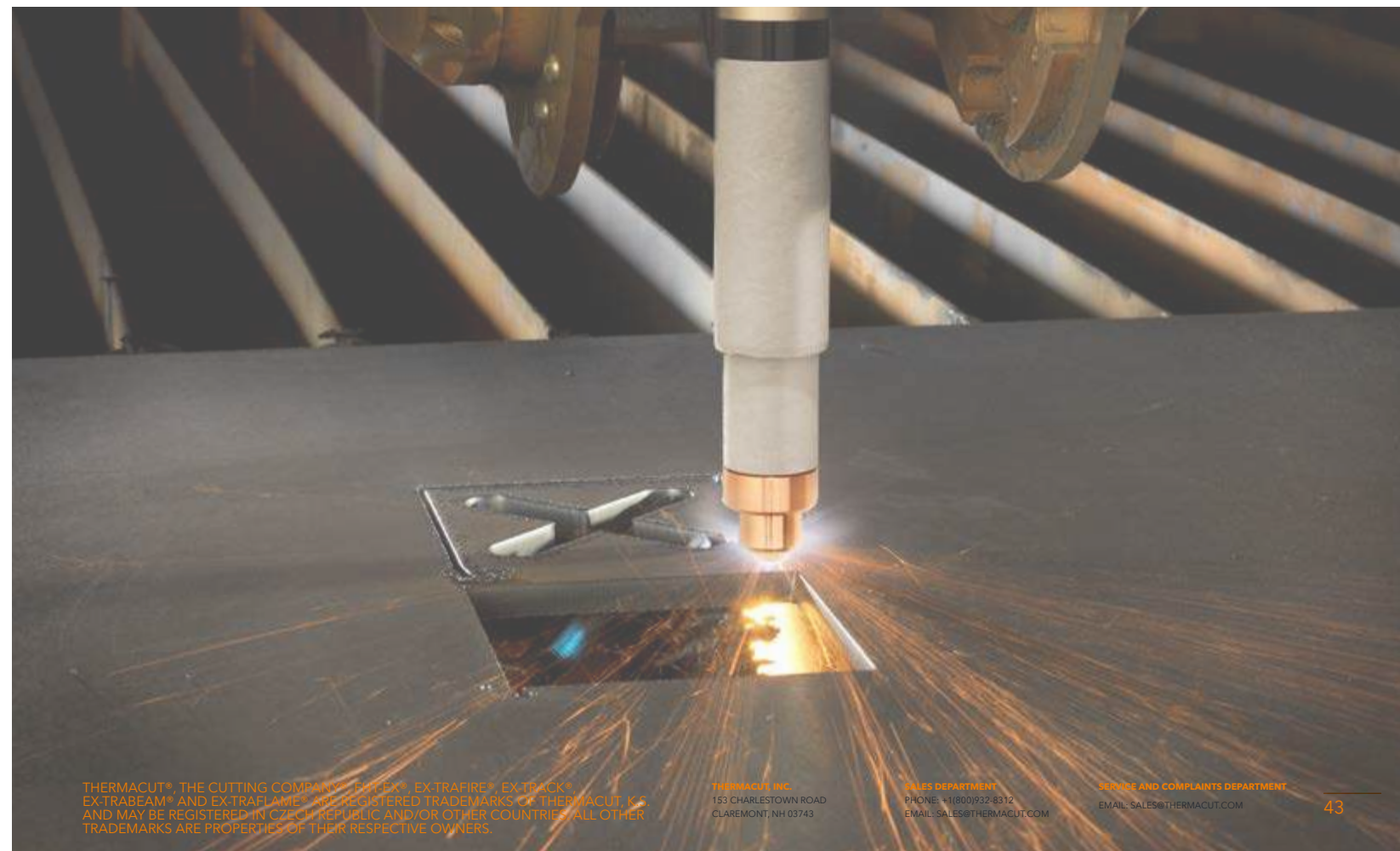
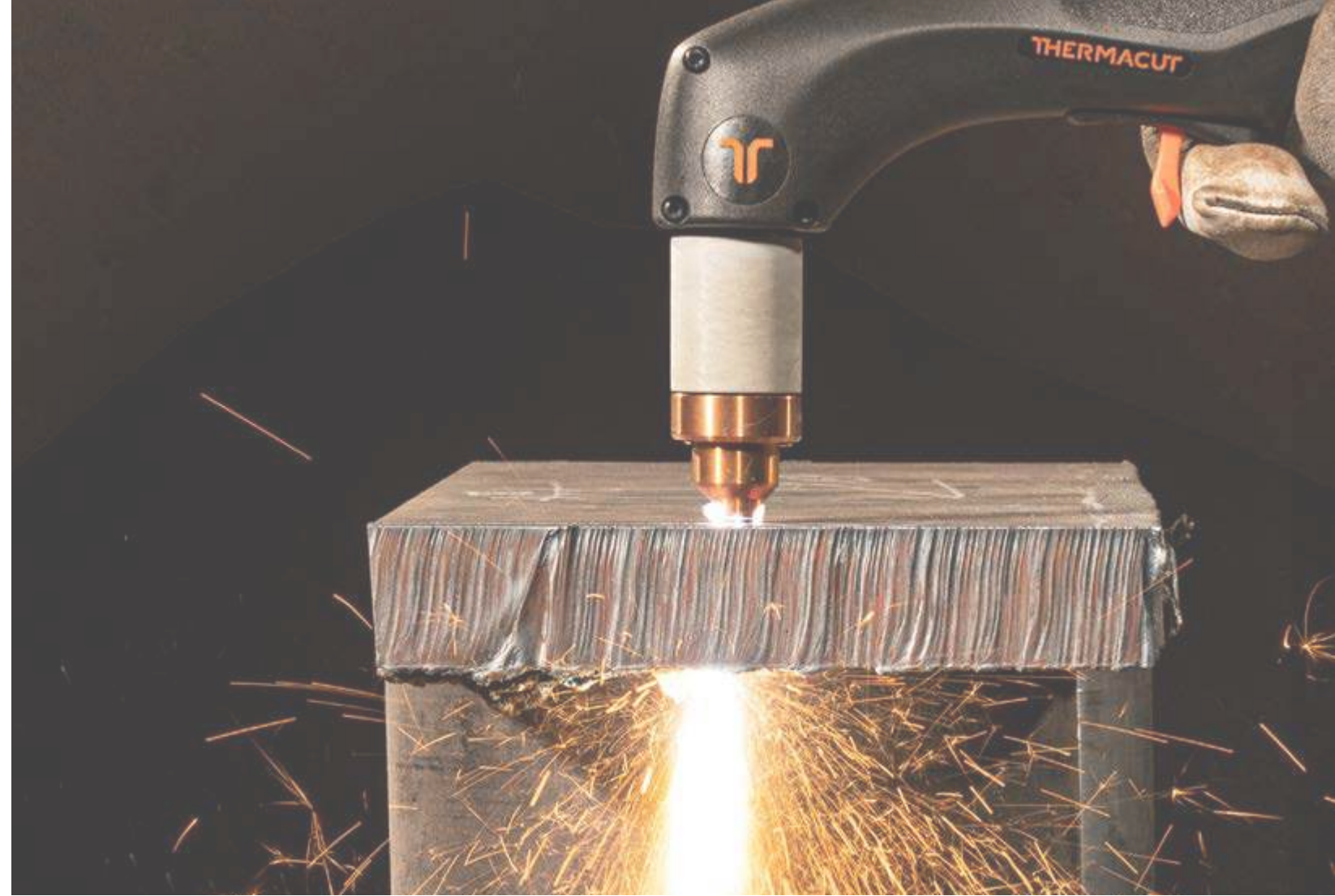

# FHT-EX® 125TT



The high-performing FHT-EX®125TT H/M hand and machine torches meet the tough demands of continuous operations. These torches are optimally designed for use with EX-TRAFIRE®125HD power supplies and are suitable for cutting, gouging, grid-cutting and marking, while allowing cut thickness up to 2-1/2" with greater precision and speed.

The THERMACUT® Torch Connection System (TCS), changing the torch is a quick and easy process. The powerful torches are the result of decades of experience in the field of plasma cutting. They feature an extremely robust and durable design in which all consumables can be replaced quickly and easily.

## BENEFITS

- High-performance torches for mechanized applications and handheld use
- Ergonomic handheld torches that increase time cutting safely in all positions
- Compact and flexible for handheld applications, even with a tight radius or the gouging of fillet welds
- 100 % duty cycle at 125 A, ideal for continuous use
- Capable of plate thicknesses up to 2 - 1/2"
- Extended life consumables
- Quick and tool-free replacement of consumables
- Piercing capabilities up to 1"

# FHT-EX® 125TTH

## HAND TORCH ASSEMBLY



Item	Part No.	Description	Pcs
1.	EX-6-139-001	FHT-EX®125TTH Hand Torch Assembly-w/o consumables w/16.5' Lead/TCS13	1
1.	EX-6-139-002	FHT-EX®125TTH Hand Torch Assembly-w/o consumables w/26.2' Lead/TCS13	1
1.	EX-6-139-003	FHT-EX®125TTH Hand Torch Assembly-w/o consumables w/49.2' Lead/TCS13	1
1.	EX-6-139-004	FHT-EX®125TTH Hand Torch Assembly-w/o consumables w/75.5' Lead/TCS13	1
a	EX-0-321-003	Latch with Key Assembly	1

**a** LATCH WITH KEY IS NOT CONTENT OF TORCHES ABOVE. IF YOU NEED IT, YOU HAVE TO ORDER SEPARATELY.

# FHT-EX® 125TT

## HAND TORCH COMPONENTS



Item	Part No.	Description	Pcs	Item	Part No.	Description	Pcs
1.	EX-6-374-001	FHT-EX®125TTH Hand Torch Lead Replacement 16.5"/TCS13	1	8.	EX-0-325-005	Male Crimp Pin for TCS Plug	1
1.	EX-6-374-002	FHT-EX®125TTH Hand Torch Lead Replacement 26.2"/TCS13	1	9.	EX-0-323-001	TCS13 Plug Body	1
1.	EX-6-374-003	FHT-EX®125TTH Hand Torch Lead Replacement 49.2"/TCS13	1	10.	EX-6-302-001	Hand Torch Body	1
1.	EX-6-374-004	FHT-EX®125TTH Hand Torch Lead Replacement 75"/TCS13	1	11.	EX-6-431-001	O-Ring (fitted on the torch body) - 2 pcs	1
2.	EX-5-318-001	TCS Plug Spring Strain Relief	1	12.	EX-6-314-001	Hand Torch Handle Replacement Kit	1
3.	EX-0-325-015	TCS Clam Shell Screw Kit (incl. 4 screws)	1	13.	EX-5-305-001	Cap-sensor Replacement Kit with Screws/ Hand Torch	1
4.	EX-0-325-002	TCS Clam Shell Upper	1	14.	EX-5-313-031	Safety Trigger	1
5.	EX-0-325-001	TCS Clam Shell Lower	1	15.	EX-6-308-001	Hand Torch Handle with Screws (6pcs)	1
6.	EX-0-325-010	Retaining Ring (Outer circlip ring)	1	16.	EX-5-313-030	Safety Trigger Micro-Switch	1
7.	EX-0-325-009	O-Ring (fitted in the TCS plug)	1	17.	EX-0-321-003	Latch w/Key Assembly	1

<sup>a</sup> LATCH WITH KEY IS NOT CONTENT OF TORCHES ABOVE. IF YOU NEED IT, YOU HAVE TO ORDER SEPARATELY.

# FHT-EX® 125TTH

## HAND TORCH CONSUMABLES - 45-65 A

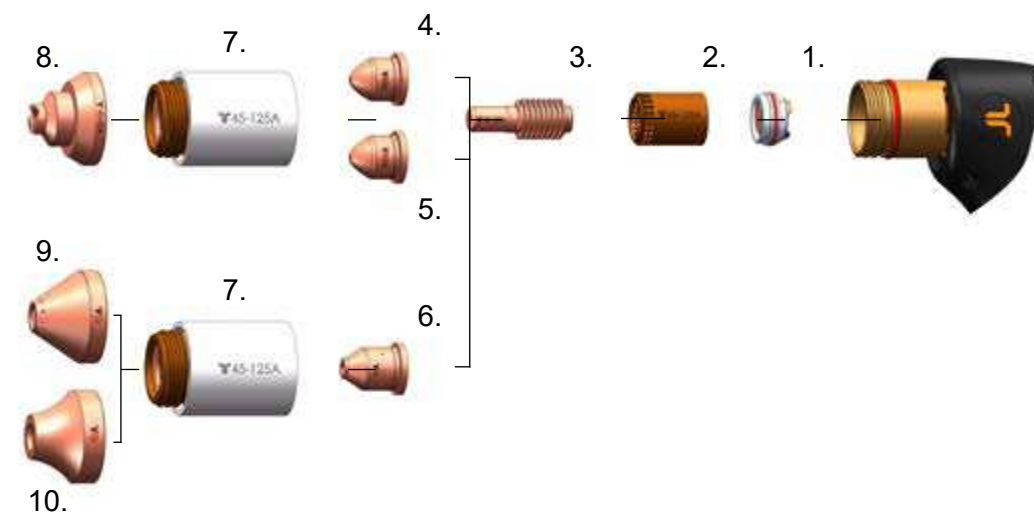

Item	Part No.	Description	Pcs	Item	Part No.	Description	Pcs
1.	EX-6-446-001	Swirl Ring Holder	1	6.	EX-6-440-020	Gouging Nozzle	1
2.	EX-6-404-021	Swirl Ring 45-125A	1	7.	EX-6-415-021	Retaining Cap 45-125A	1
3.	EX-6-401-021	Electrode 45-125A (5pcs package)	1	8.	EX-6-419-022	Shield 45-65A, Hand	1
4.	EX-6-409-024	Nozzle 45A	1	9.	EX-6-440-023	Gouging Shield, Standard	1
5.	EX-6-409-023	Nozzle 65A	1	10.	EX-6-440-024	Gouging Shield, High Removal	1

## HAND TORCH CONSUMABLES - 85-125 A

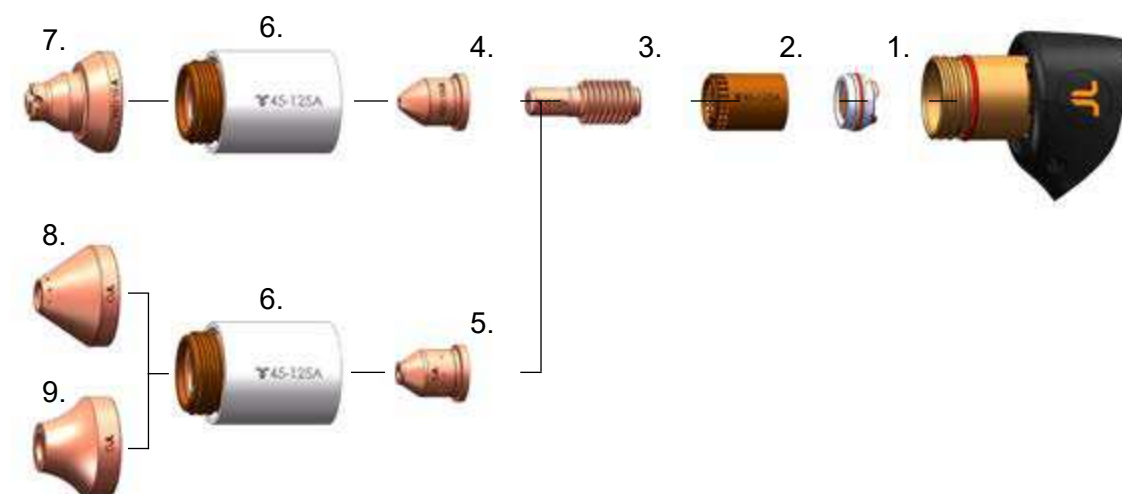

Item	Part No.	Description	Pcs	Item	Part No.	Description	Pcs
1.	EX-6-446-001	Swirl Ring Holder	1	6.	EX-6-415-021	Retaining Cap 45-125A	1
2.	EX-6-404-021	Swirl Ring 45-125A	1	7.	EX-6-419-021	Shield 85-125A, Hand	1
3.	EX-6-401-021	Electrode 45-125A (5pcs package)	1	8.	EX-6-440-023	Gouging Shield, Standard	1
4.	EX-6-409-021	Nozzle 85-125A	1	9.	EX-6-440-024	Gouging Shield, High Removal	1
5.	EX-6-440-020	Gouging Nozzle	1				





# FHT-EX® 125TTM

## MACHINE TORCH CONSUMABLES - 45-65 A

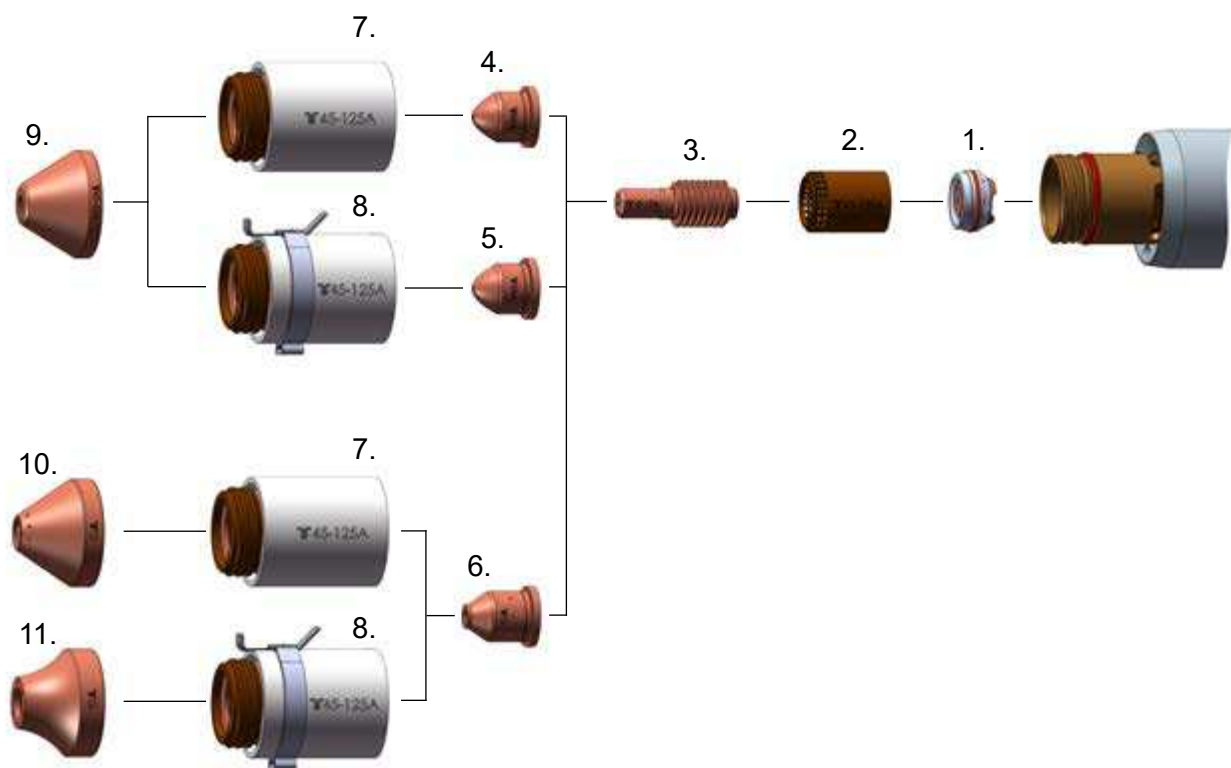

Item	Part No.	Description	Pcs	Item	Part No.	Description	Pcs
1.	EX-6-446-001	Swirl Ring Holder	1	7.	EX-6-415-021	Retaining Cap 45-125A	1
2.	EX-6-404-021	Swirl Ring 45-125A	1	8.	EX-6-415-022	Retaining Cap 45-125A, IHS Tab	1
3.	EX-6-401-021	Electrode 45-125A (5pcs package)	1	9.	EX-6-421-022	Shield 45-65A, Machine	1
4.	EX-6-409-024	Nozzle 45A	1	10.	EX-6-440-023	Gouging Shield, Standard	1
5.	EX-6-409-023	Nozzle 65A	1	11.	EX-6-440-024	Gouging Shield, High Removal	1
6.	EX-6-440-020	Gouging Nozzle	1				

# FHT-EX® 125TTM

## MACHINE TORCH CONSUMABLES - 85-125 A

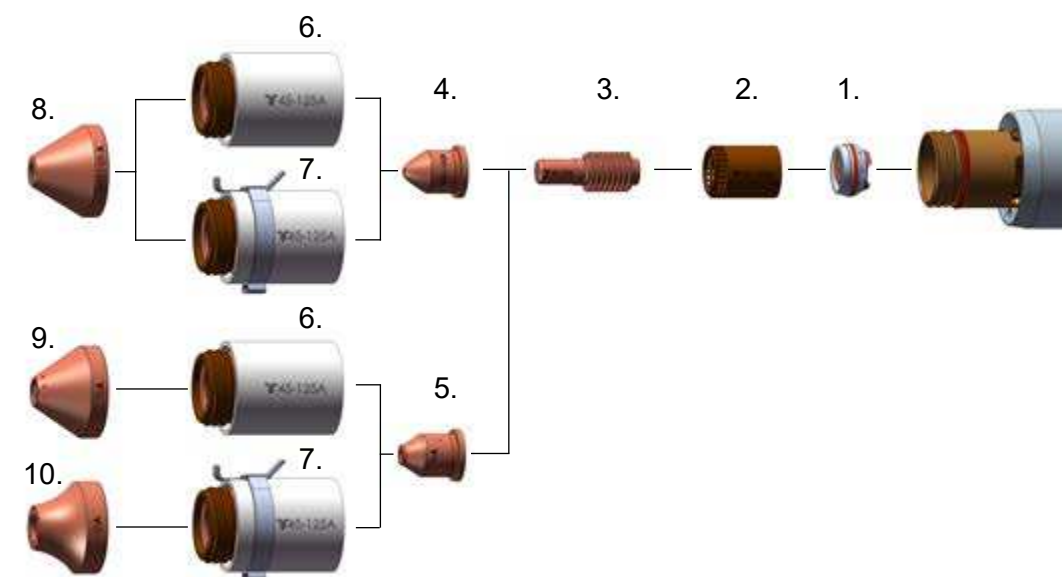

Item	Part No.	Description	Pcs	Item	Part No.	Description	Pcs
1.	EX-6-446-001	Swirl Ring Holder	1	6.	EX-6-415-021	Retaining Cap 45-125 A	1
2.	EX-6-404-021	Swirl Ring 45-125 A	1	7.	EX-6-415-022	Retaining Cap 45-125 A, IHS Tab	1
3.	EX-6-401-021	Electrode 45-125 A (5 pcs package)	1	8.	EX-6-421-021	Shield 85-125 A, Machine	1
4.	EX-6-409-021	Nozzle 85-125 A	1	9.	EX-6-440-023	Gouging Shield, Standard	1
5.	EX-6-440-020	Gouging Nozzle	1	10.	EX-6-440-024	Gouging Shield, High Removal	1

## MACHINE TORCH CONSUMABLES - SMOOTHLINE

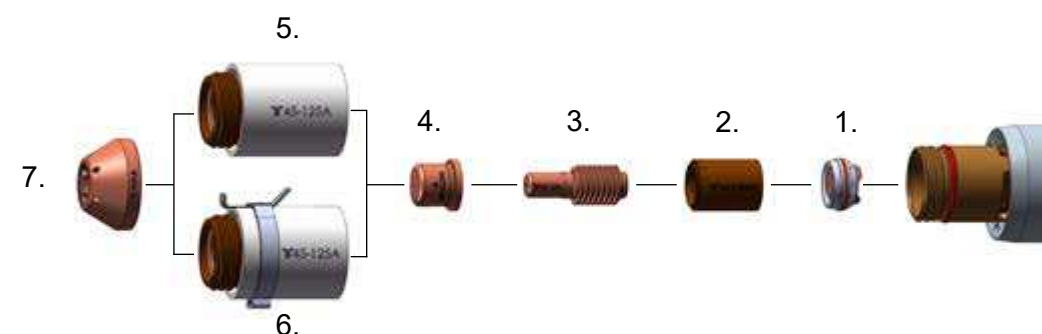

Item	Part No.	Description	Pcs	Item	Part No.	Description	Pcs
1.	EX-6-446-001	Swirl Ring Holder	1	5.	EX-6-415-021	Retaining Cap 45-125 A	1
2.	EX-6-440-021	Swirl Ring SmoothLine	1	6.	EX-6-415-022	Retaining Cap 45-125 A, IHS Tab	1
3.	EX-6-401-021	Electrode 45-125 A (5 pcs package)	1	7.	EX-6-414-022	SmoothLine Shield	1
4.	EX-6-414-021	SmoothLine Nozzle	1				



# THINK FRESH. CUT ORANGE.

**THERMACUT, INC**  
153 CHARLESTOWN ROAD  
CLAREMONT, NH 03743

EMAIL: SALES@THERMACUT.COM  
PHONE: +1(800)932-8312  
**WWW.THERMACUT.COM**

follow  
**#EXTRAFIRE**

