



REAL

WORK
HORSES

FROM KENTUCKY



WDM 403 Series 4-Roll Double Pinch Plate Bending Machines

Waldemar Design & Machine LLC
1797 Matherly Road, Liberty, KY 42539 • 606-787-8474

Jan 2011

403 Series Plate Bending Machines



The 403 SERIES 4-ROLL DOUBLE PINCH PLATE BENDING MACHINE is in a sense a 3-ROLL INITIAL PINCH PLATE BENDING MACHINE with an extra bending roll on the front side of the pinch rolls. The advantage of this type of machine is that it enables the operator to roll the workpiece from the leading to the trailing edge with minimal and usually negligible flats. As a rule of thumb, the flats are less than 1 1/2 to 2 times the work piece thickness. This can be accomplished in a single pass without turning the workpiece. See forming procedure for details (page 10).

403-6-6 (7/32" x 6') Standard machine equipped with optional dual foot pedal for roll rotation. The machine as equipped with standard features is a very functional machine and does not require any options to roll cylindrical workpieces.



403-7-6 Equipped with 424-3 machine mounted preset type control, dual foot pedal for roll rotation, and cone attachment.



403-12-10 (1/2" x 10') This machine is used in a plant which manufactures steel stacks, sewage processing equipment, and grain and dust handling equipment. Equipped with flame hardened rolls, 2 dual-purpose side supports/infeed tables, overhead support, dual roll rotation foot pedal, and 423-3-LP6 control; which provides 2 presets for each roll position and 6 presets for rolling lengths.

Standard Features

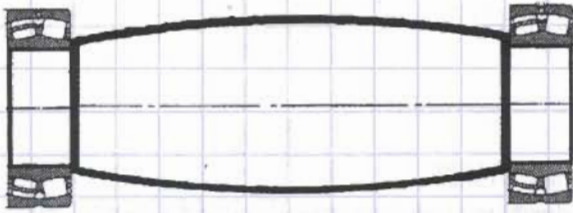

ROLLS

The heart of the WDM 4-roll plate bending machine is the rolls themselves. These rolls are machined from 1045/50 steel bars or forgings. They are crowned to compensate for deflection and supported on sealed, self-aligning, spherical bearings requiring minimal maintenance. These rolls are sized according to the load imposed during the rolling cycle, making the machine more compact and streamlined than before without affecting the capacity.

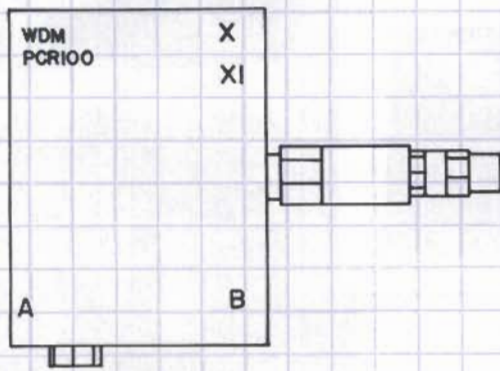

RESTORING PARALLELISM OF ROLLS

Restoring parallelism of rolls is accomplished by a special valve arrangement designed by WDM which is activated when the roll is lowered to the bottom and held momentarily until all movement ceases. Roll is then parallel with top roll.



ROLL POSITION INDICATORS

These very practical and trouble free roll position indicators consist of an etched dial and pointer located on main housing facing operator's position. Various other indicators are available. See options (pages 6 and 7).

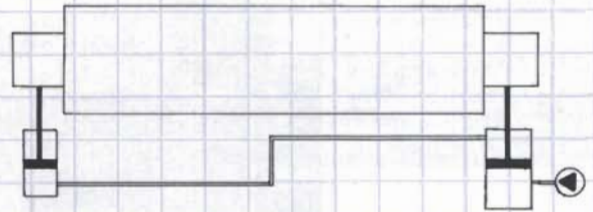

ROLL SUPPORT AND ADJUSTMENT

The bearings that hold the rolls are supported on a set of master and slave hydraulic cylinders with very effective seals and travel in a radial path (bending) and a straight path (pinch).



CONTROL OF ROLLS

The hydraulic circuit is fitted with a half-turn valve that allows all adjustable rolls to be angled for cone rolling, etc. The control also contains motor starting switch, function speed control, pinch roll pressure regulator, and indicator gauge.

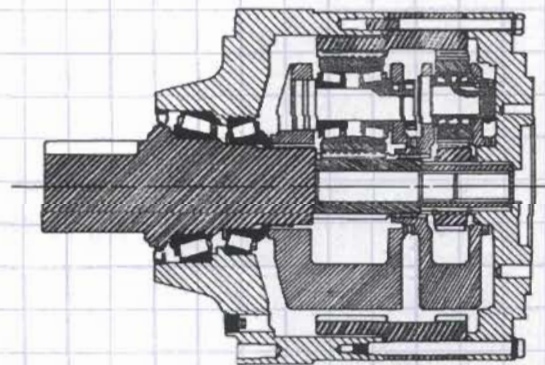

ROLL DRIVE

The top and bottom center rolls are driven by individual low speed, high torque type hydraulic motors with very high volumetric and overall efficiency. The motors are coupled to rolls with rigid couplings and planetary and/or spur gear type speed reducers. (4" & 5" roll machines do not have speed reducers.) Top and bottom roll speeds are hydraulically synchronized and equalized. This drive type provides highly efficient transfer of torque.

Standard Features (cont'd)

Operator's view of standard machine's control area.



Close up view of system speed control knob on a manual control style.

CONTROL VALVES

The control valves are manual actuation type and mounted on main machine housing. This standard feature gives excellent feel and feathering capability to the operator's finger tips. Many other controls are available. See options (pages 6 and 7).

FRAME

All this is housed in a compact, streamlined, fabricated, and machined steel frame composed of steel plates and robust structural sections.

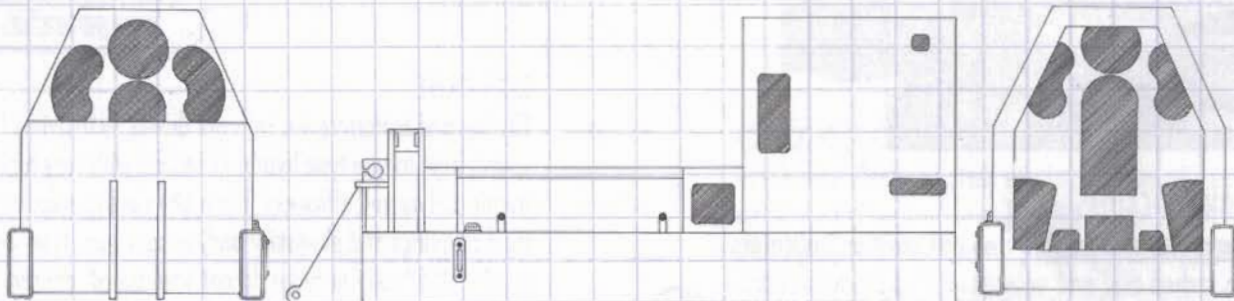

HYDRAULIC SYSTEM

The hydraulic reservoir is an integral part of the machine frame which helps dissipate system heat. This and careful attention to efficiency of components keeps the hydraulic system cool. The pump, valves, and other hydraulic components are sized and designed with maximum efficiency and function in mind.

Control knob on electric control styles.



SPEED CONTROL

The speed of the entire system is controlled via a flow control knob located on the main housing near the operator's station. This knob controls the roll rotation and the adjustment speeds. Individual speed control is available as an option on smaller machines and standard on larger machines (403-12 and above.)

Standard Features (cont'd)

WARNING

We have incorporated safety features into the machine. It is the employer/owner's responsibility to supply any additional point-of-operation guards, or operating procedures as may be required for safe operation of his particular purpose.

ELECTRICAL SYSTEM

The electrical system is housed in NEMA 12 enclosures and is installed in accordance with NFPA-79 specifications. Motors are efficient, totally enclosed, fan cooled, hostile environment type.

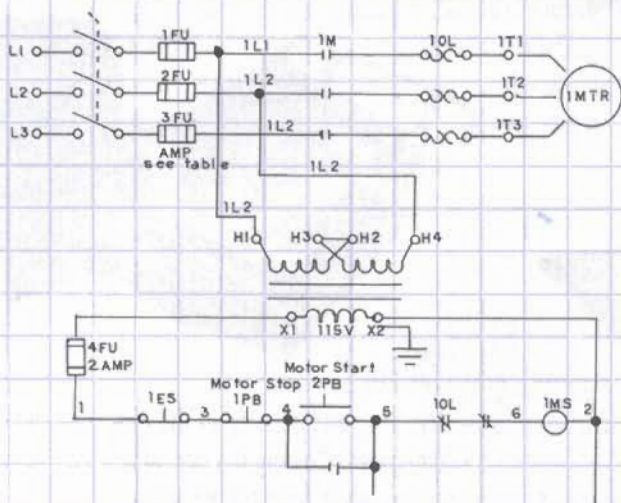

FINISH

Machine is finished with V.O.C. compliant haze gray epoxy and safety blue enamel.

SAFETY CABLE

A safety cable on three sides of the machine allows anyone to stop the machine by tripping the wire. Its switch incorporates a feature which makes it impossible to start the machine unless the cable is installed with proper tension. (Light curtains and safety mats are available as optional accessories.)

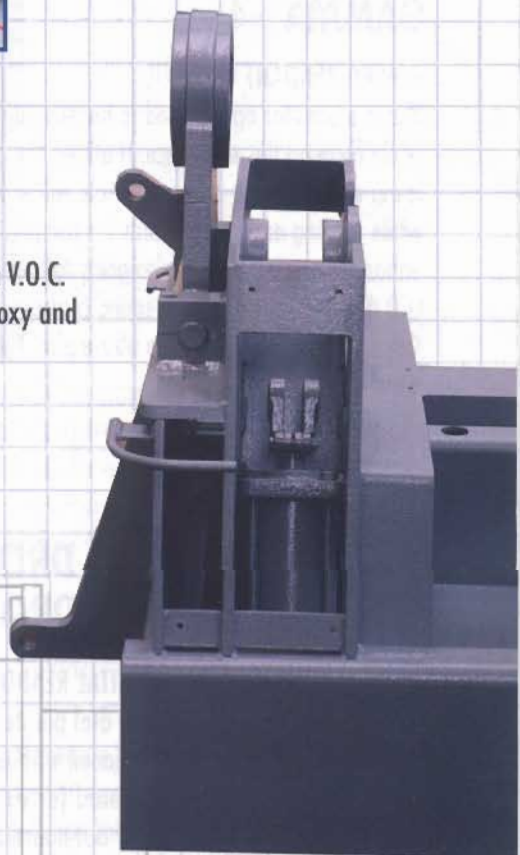

Some Standard Options Available

GFP

DUAL GUARDED FOOT PEDAL

This feature is available for forward and reverse rotation of the rolls, allowing operator to use both hands to manipulate workpiece and can be used on all control styles.



ALPHA - 4

BETA - 4

GAMMA - 4

ROVING PENDANT CONTROL

This is a popular option used to increase the mobility of the operator while forming the workpiece. It allows the operator to raise and lower all adjustable rolls and rotate roll in forward and reverse while moving anywhere within the range of the attaching cord. The enhanced version **Beta 4** also gives roll position indication through LCD displays and electronic speed control via a 270° turn knob. **Gamma 4** provides all of the above plus 1 preset for each of the bending rolls.



L

LENGTH INDICATION D.R.O. L

A digital readout (Series L) can be provided to indicate length rolled in hundredths (.00) of an inch. This aids in rolling flat-radius, flat-radius-flat, or variable radii type workpiece.



SC - 422 - VC

SC

SWINGING CONSOLE TYPE CONTROL

This console is mounted on the drop-end housing of the machine and swivels about 120 degrees allowing the operator to view both sides of the machine while forming the workpiece. This control has all the advantages of the manual type valves with the additional advantage of some movement. The optional D.R.O. indicators are installed on this console.



FSC 423

FREE STANDING CONSOLE

This is similar to the above feature except roll movement and rotation functions are controlled by joysticks mounted on the console. The drop-end controls, motor start-stop, and emergency stop buttons are also mounted on the console.

A very popular version, the enhanced model 423 series controls provide just enough automation to greatly speed through put, performance, and accuracy by providing 2 presets for each adjustable roll and up to 6 presets for the rolling length. It is easily programmed and can be used as a standard or preset type control. In many cases this increases roll performance 500% or more and is usually all the automation that is required. This control can also be machine mounted. See photos, lower left and right on page 2.

421 DRO

422 DRO

DIGITAL READOUTS

The dial pointer type controls can be replaced with electronic digital readouts on inboard (drive-end) Series 421, or inboard and out-board (drop-end) Series 422, useful for cone rolling. They can be machine mounted as shown at left or mounted on control console as shown below.



FSC - 423 - LP6

Some Standard Options Available (cont'd)

LP LP-6



LENGTH INDICATION DRO WITH PRESET LP2-LP6

This control is same as Series L except that additionally it incorporates 2 pre-programmable presets (Series LP) which stop the machine when preset length is reached. Also available is the model Series LP6 which has 6 preset positions instead of 2. (These features cannot be used with manual valve models.)

424 - 3

CONE ROLLING CONTROL

The 424-3 is identical to the Series 423, shown lower right on page 6, except it has an LCD readout for indicating the roll position at drop end. Useful when rolling cones.



425 - 4

AUTOMATIC CYCLE CONTROL 425-4

The Series 425-4 control is used for high volume production. After entering the workpiece the operator depresses the guarded foot pedal which initiates the cycle. The machine completes all forming functions automatically.



It is also possible to use this machine manually or in a manual with preset mode when automatic operation is not desirable. If the machine is equipped with a feeder or parts ejector they are also operated by this control. The control console can be mounted on drive-end, or drop-end, or be free standing.

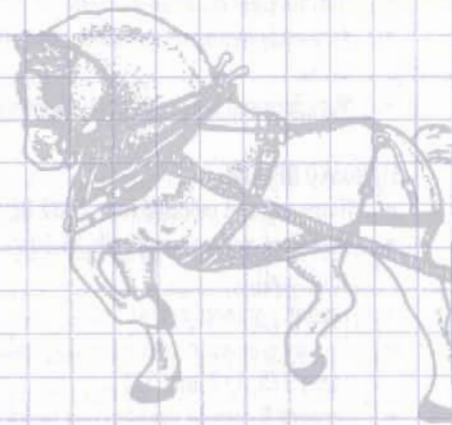

CA HDCA (Heavy Duty)

CONE ROLLING ATTACHMENT

The cone attachment consists of an indexable and replaceable hardened-steel nose mounted on a bronze or composite-bushed steel sleeve which slides onto the reduced diameter portion of the top roll next to the drop-end. It is locked into position by the drop-end and removed when not rolling cones. Heavy duty cone rolling attachments are available for shops doing large amounts of cone rolling.

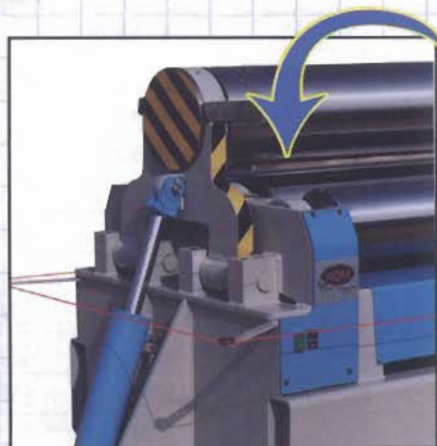

Capacity Ratings and Specifications

For WDM 403 Series Double Pinch Pyramid Plate Rolls

STANDARD FEATURES

- 1045 Steel rolls machined to 63 micro inches
- Total hydraulic operation
- Instant start-stop-reverse
- Roll speed infinitely variable 0 to 22 FPM (0 to 14 FPM on larger machines)
- 2 Roll drive
- 3 Phase 230/460 Volts
- Electrics to NFPA-79 specifications
- 24V-120 AC control circuit
- Safety/emergency stop cable on 3 sides of the machine
- Overload protected
- TEFC main motor
- Quiet hydraulic system
- Haze gray epoxy and blue enamel finish (V.O.C. compliant)
- Sealed spherical roller bearings on all main points
- Hydraulically actuated drop-end
- Accurately machined, compact, streamlined, all welded steel frame
- Manufactured in Casey County, Kentucky, USA

STANDARD OPTIONS

- Hardened and polished rolls 28-32 Rc. (4140 HT)
- Hardened and polished rolls 55-60 Rc. (1045 flame hardened)
- Squaring grooves in lower rolls
- Circular grooves in rolls for rolling rods or sheets with wire edges 3/8, 1/2, and 5/8
- Forward & reverse guarded foot pedal for roll rotation
- Cone attachment
- Heavy duty cone attachment
- DRO for roll position instead of dial pointer indicator (**Series 421**)
- Same as above on both ends of rolls (**Series 422**)
- DRO with 2-preset stops for roll position indicators and control (**Series 423**)
- Same as above with an additional DRO to show position of outboard end of roll (**Series 424**) useful for cone rolling
- DRO length indicator to show length rolled to facilitate forming of flat-radius-flat, etc. type workpiece (**Series L**)
- Same as above with 2 presets (**Series LP**)
- Same as above with 6 presets (**Series LP6**)
- Electric roving pendant control to replace manual valves on machine housing
- **Alpha 4, Beta 4, Gamma 4**
- Automatic cycle PLC control for high production (**Series 425-4**)
- Independent roll rotation and roll adjustment speed control (standard on larger machines 403-12 and above)
- Non-Electric version

Model	Rated Capacity	Nominal Top Roll Diameter	Horsepower	Size L x W x H	Estimated Weight
403-5-4	.164 x 4	5	3	93 x 34 x 34	2000
403-6-4	5/16 x 4	6	5	93 x 41 x 38	2850
403-7-4	3/8 x 4	7	5	95 x 41 x 38	3800
403-8-4	1/2 x 4	8	7.5	106 x 44 x 41	5000
403-9-4	5/8 x 4	9	10	106 x 44 x 41	6350
403-10-4	23/32 x 4	10	10	111 x 46 x 46	8900
403-11-4	7/8 x 4	11	15	111 x 46 x 46	11000
403-12-4	1-1/16 x 4	12	20	113 x 47 x 50	12800
403-13-4	1-1/4 x 4	13	25	113 x 47 x 50	15000
403-14-4	1-7/16 x 4	14	40	120 x 78 x 66	18800
403-15-4	1-5/8 x 4	15	50	120 x 78 x 66	22500
403-16-4	1-3/4 x 4	16	50	123 x 82 x 68	24300
403-17-4	2 x 4	17	60	123 x 82 x 68	28000
403-18-4	2-1/4 x 4	18	60	135 x 90 x 78	31100
403-19-4	2-1/2 x 4	19	75	135 x 90 x 78	35000
403-5-5	.135 x 5	5	3	105 x 34 x 34	2300
403-6-5	1/4 x 5	6	5	107 x 41 x 38	3400
403-7-5	5/16 x 5	7	5	107 x 41 x 38	4500
403-8-5	3/8 x 5	8	7.5	108 x 44 x 41	5800
403-9-5	1/2 x 5	9	10	108 x 44 x 41	7400
403-10-5	5/8 x 5	10	10	123 x 46 x 46	10300
403-11-5	28/32 x 5	11	15	123 x 46 x 46	12600
403-12-5	7/8 x 5	12	20	125 x 47 x 50	14700
403-13-5	1-1/16 x 5	13	25	125 x 47 x 50	17300
403-14-5	1-1/4 x 5	14	40	132 x 78 x 66	21300
403-15-5	1-7/16 x 5	15	50	132 x 78 x 66	25700
403-16-5	1-5/8 x 5	16	50	135 x 82 x 68	27700
403-17-5	1-3/4 x 5	17	60	135 x 82 x 68	32000
403-18-5	2 x 5	18	60	147 x 90 x 78	36000
403-19-5	2-3/16 x 5	19	75	147 x 90 x 78	40000
403-5-6	.104 x 6	5	3	117 x 34 x 34	2700
403-6-6	7/32 x 6	6	5	119 x 41 x 38	3850
403-7-6	9/32 x 6	7	5	119 x 41 x 38	5100
403-8-6	3/8 x 6	8	7.5	130 x 44 x 41	6700
403-9-6	7/16 x 6	9	10	130 x 44 x 41	8500
403-10-6	9/16 x 6	10	10	135 x 46 x 46	11600
403-11-6	11/16 x 6	11	15	135 x 46 x 46	14300
403-12-6	13/16 x 6	12	20	137 x 47 x 50	16550
403-13-6	1 x 6	13	25	137 x 47 x 50	19500
403-14-6	1-1/8 x 6	14	40	144 x 78 x 66	23900
403-15-6	1-1/4 x 6	15	50	144 x 78 x 66	29800
403-16-6	1-3/8 x 6	16	50	147 x 82 x 68	31100
403-17-6	1-1/2 x 6	17	60	147 x 82 x 68	35800
403-18-6	1-5/8 x 6	18	60	159 x 90 x 78	39900
403-19-6	1-3/4 x 6	19	75	159 x 90 x 78	44800

Model	Rated Capacity	Nominal Top Roll Diameter	Horsepower	Size L x W x H	Estimated Weight
403-5-8	.060 x 8	5	3	141 x 34 x 34	3400
403-6-8	.140 x 8	6	5	143 x 41 x 38	4800
403-7-8	3/16 x 8	7	5	143 x 41 x 38	6400
403-8-8	1/4 x 8	8	7.5	154 x 44 x 41	8500
403-9-8	5/16 x 8	9	10	154 x 44 x 41	10700
403-10-8	13/32 x 8	10	10	159 x 46 x 46	14200
403-11-8	33/64 x 8	11	15	159 x 46 x 46	17500
403-12-8	5/8 x 8	12	20	161 x 47 x 50	20400
403-13-8	47/64 x 8	13	25	161 x 47 x 50	24000
403-14-8	55/64 x 8	14	40	168 x 78 x 66	27900
403-15-8	63/64 x 8	15	50	168 x 78 x 66	33700
403-16-8	1-7/64 x 8	16	50	171 x 82 x 68	36300
403-17-8	1-17/64 x 8	17	60	171 x 82 x 68	41900
403-18-8	1-27/64 x 8	18	60	183 x 90 x 78	46600
403-19-8	1-37/64 x 8	19	75	183 x 90 x 78	52300
403-5-10	.048 x 10	5	3	165 x 34 x 34	4000
403-6-10	.094 x 10	6	5	167 x 41 x 38	5800
403-7-10	.125 x 10	7	5	167 x 41 x 38	7700
403-8-10	11/64 x 10	8	7.5	178 x 44 x 41	10400
403-9-10	15/64 x 10	9	10	178 x 44 x 41	12900
403-10-10	5/16 x 10	10	10	183 x 46 x 46	16900
403-11-10	25/64 x 10	11	15	183 x 46 x 46	20800
403-12-10	1/2 x 10	12	20	185 x 47 x 50	24200
403-13-10	19/32 x 10	13	25	185 x 47 x 50	28500
403-14-10	11/16 x 10	14	40	192 x 78 x 66	34300
403-15-10	51/64 x 10	15	50	192 x 78 x 66	41500
403-16-10	57/64 x 10	16	50	195 x 82 x 68	44600
403-17-10	1-1/32 x 10	17	60	195 x 82 x 68	51500
403-18-10	1-5/32 x 10	18	60	207 x 90 x 78	57300
403-19-10	1-9/32 x 10	19	75	207 x 90 x 78	64300
403-5-12	.035 x 12	5	3	189 x 34 x 34	4700
403-6-12	.062 x 12	6	5	191 x 41 x 38	6750
403-7-12	.094 x 12	7	5	191 x 41 x 38	9000
403-8-12	.125 x 12	8	7.5	202 x 44 x 41	11850
403-9-12	11/64 x 12	9	10	202 x 44 x 41	15100
403-10-12	15/64 x 12	10	10	207 x 46 x 46	19500
403-11-12	9/32 x 12	11	15	207 x 46 x 46	24100
403-12-12	3/8 x 12	12	20	209 x 47 x 50	2800
403-13-12	7/16 x 12	13	25	209 x 47 x 50	33000
403-14-2	35/64 x 12	14	40	216 x 78 x 66	40000
403-15-12	5/8 x 12	15	50	216 x 78 x 66	48000
403-16-2	3/4 x 12	16	50	219 x 82 x 68	51400
403-17-12	13/16 x 12	17	60	219 x 82 x 68	59300
403-18-12	15/16 x 12	18	60	231 x 90 x 78	66000
403-19-12	1 x 12	19	75	231 x 90 x 78	74100

STANDARD OPTIONS (CONT'D)

- Side supports
- Overhead supports, feed tables, automatic feeders, manual and automatic ejectors
- Special electrics
- Special customer supplied paint

NON-STANDARD OPTIONS

- Chromed rolls
- Special extra smooth rolls
- Special grooves in rolls
- High-speed version
- Many, many more. Let us know your needs.

WORKPIECE ACCURACY

In the final analysis, the proof of performance is the acceptability of the finished workpiece. With uniform quality of the workpiece blanks, our machines have historically rolled workpieces within 1/2 of 1% of perfect concentricity.

There are many variables that can affect the accuracy and repeatability either minimally or drastically. These include, but are not limited to, the following: varying material thickness; varying material temper; uneven cross section of material, i.e. wide and narrow profile of workpiece or a workpiece with holes or cutouts; and direction of grain of material.

Many of these variables can be overcome by various means. An important element for success is a knowledgeable operator who understands the characteristics of the material being formed and the various functions of the machine. If the workpiece being formed is anything other than uniform material and cylinders, and you are unsure if your pieces can be rolled practically, please, provide us with a drawing or sketch and we will be happy to evaluate it.

Also available is *The Rolling Digest* (showing many tips and procedures) at \$35.00 a copy. Order from main office.

NOTES

Capacity is based on 40,000 p.s.i. yield strength material. These machines are also available in 2, 3, 14, 16, 18, and 20 feet and longer lengths. Please inquire for price and availability. Verify dimensions and specifications.

We reserve the right to make changes in design and specifications without obligation or notification.

Forming Procedure

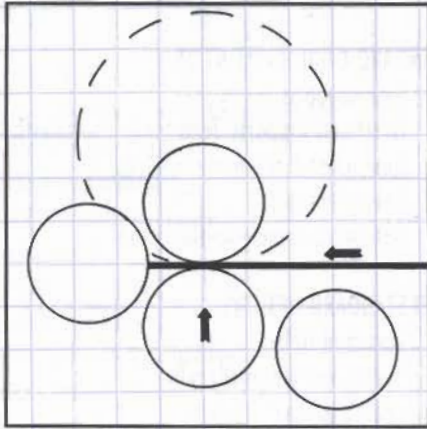

Workpiece is entered into the machine and squared against far bending roll. Center (pinch) roll is raised to grip workpiece.

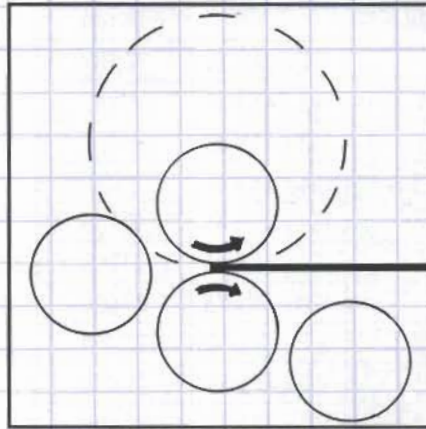

Roll is reversed until leading edge of workpiece nears center of roll.

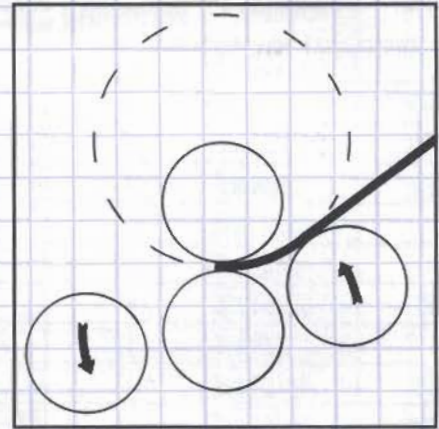

Far bending roll is lowered. Near bending roll is raised to pre-bend position.

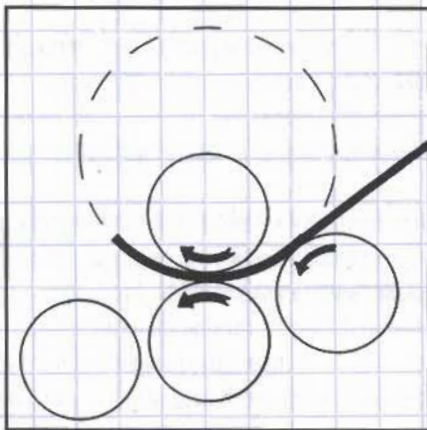

Rolls are rotated forward until pre-bend is complete.

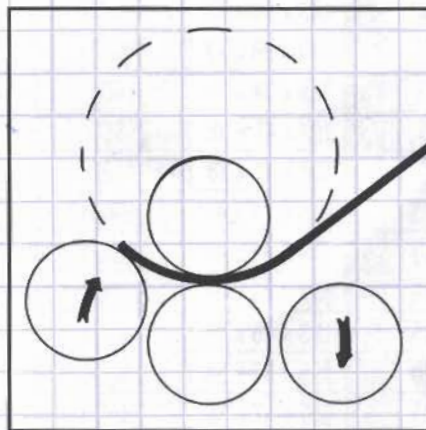

Near bending roll is lowered. Far bending roll is raised to rolling position.

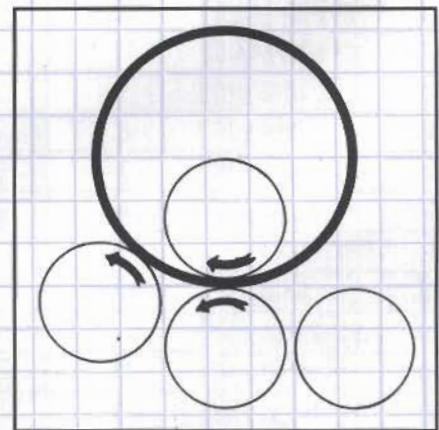

Workpiece is rolled to completion.

Notice: Only three rolls contact the workpiece during each step of the forming procedure.

LOCATION AND SERVICE

Our plants in Liberty, Kentucky, house our sales, engineering, manufacturing, R & D, parts, and accounting departments. We are represented in the USA, Canada, Central and South America by independent sales representatives and dealers.

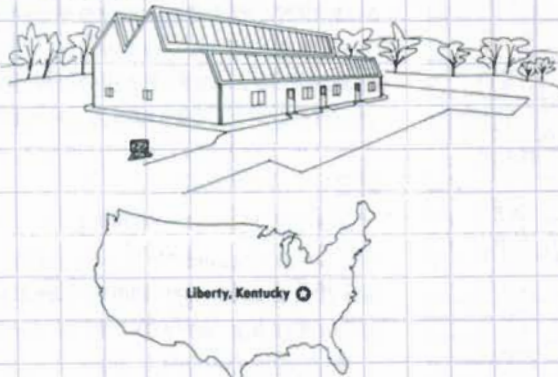

Our location in east central United States puts us in close proximity to all major industrial areas in the eastern United States. Our machines are designed to use many standard off-the-shelf components that are readily available from industrial supply houses or from our stock.

WARRANTY

Waldemar Design & Machine warrants its products to be free from defects in material and workmanship for a period of one year from date of manufacture.

Waldemar's obligation is to replace, free of charge, any defective part of any product that its inspection shows to be defective, including the lowest priced round trip transportation to Waldemar's plant in Liberty, KY, from any point in the 48 contiguous states.

Waldemar shall not be liable for installation and removal expense, loss of time, manufacturing costs, labor, material, loss of profits, or consequential damages direct or indirect, because of defective products. There is no other warranty, express or implied.

TRAINING

Waldemar Design & Machine strongly encourages the dealer and/or customer to visit our plant upon completion of the machine to receive free training on the machine's operation and maintenance.

WDM Users and Suppliers

SOME WDM USERS

AEROQUIP CORPORATION - AERO SPACE DIVISION
AGRIFAB - LAWN & GARDEN EQUIPMENT
AMERICAN YARD PRODUCTS - LAWN & GARDEN EQUIPMENT
BABCOCK & WILCOX - POWER PLANT BUILDERS
BELOIT JONES - PAPER MILL MACHINERY
BETTS INDUSTRIES - TANK COMPONENTS
CARRIER CORPORATION - AIR CONDITIONING
COOPER LIGHTING - LIGHTING PRODUCTS
CORNELL UNIVERSITY
CHRYSLER CORPORATION - AUTOMOTIVE
DAYTON POWER & LIGHT - POWER GENERATION
DONALDSON/TORIT - AIR FILTRATION
DRESSER INDUSTRIES - TURBINE MFG
DYNAMIC WELDING - S.S. PROCESSING VESSELS
ELDERLEE - GUARDRAIL PRODUCTS
ENGINEERED STORAGE PRODUCTS - FOOD STORAGE TANKS
FIELDER CORPORATION - PAPER MILL MACHINES
FELDMIER EQUIPMENT - FOOD PROCESSING EQUIPMENT

FORD MOTOR - AUTOMOTIVE
GENERAL MOTORS - AUTOMOTIVE
GEORGIA TANK - UNDERGROUND STORAGE TANKS
GLAXO - PHARMACEUTICAL
GREAT DANE - TRAILERS
HARTZELL FAN - VENTILATION
HIBBING TALCONITE - ORE MINING
HUTCHINSON MAYRATH - GRAIN HANDLING EQUIPMENT
JUMP KING - TRAMPOLINES
NASA - AEROSPACE
NATIONAL STEEL AND SHIPBUILDING - SHIPYARD
OLSON INDUSTRIES - AIRPORT LIGHTING PRODUCTS
OSHKOSH - CLOTHING MFG
OXMASTER - CHEMICAL EQUIPMENT
PANAMA CANAL - WATER WAY
PEOBODY TECHTANK - PLASTIC STORAGE EQUIPMENT
PLAYWORLD SYSTEMS - PLAYGROUND EQUIPMENT
QUALITY STEEL - PROPANE TANKS

ROUGH BROTHERS - GREENHOUSES
SANITARY PROCESSING - FOOD PROCESSING EQUIPMENT
SEPTA - MASS TRANSIT
STANDARD PRESSURE PIPE - PIPING
STEEL FAB - AIR RECEIVERS
SWECO - FILTRATION SYSTEMS
TEXACO REFINERY - PETROLEUM
UNION ELECTRIC - NUCLEAR GENERATION PLANT
US STEEL - MINE
UTICA BOILER - RESIDENTIAL HEATING
WASHTENAW COMMUNITY COLLEGE
WALKER STAINLESS - FOOD PROCESSING & TRANSPORT
WESTINGHOUSE - PUMP DIVISION
WORTHINGTON CYLINDERS - PRESSURE VESSELS

Many, many more fabrication shops, welding shops, tank shops, machine builders, etc.

SOME WDM SUPPLIERS

ALLEN BRADLEY - ELECTRICS
AUBURN GEAR - PLANETARY DRIVES
BROWNING - DRIVE COMPONENTS
CHAR-LYNN/EATON CORP. - LSHT HYDRAULIC MOTORS
COMMERCIAL INTERTECH - HYDRAULIC COMPONENTS
EARLE M. JORGENSEN - STEEL SUPPLIER
ESKRIDGE - PLANETARY DRIVES
HOFFMAN - ELECTRICAL ENCLOSURES
HYDRA FORCE - HYDRAULIC COMPONENTS

LINCOLN ELECTRIC - MOTORS
LINN GEAR - GEARS AND SPROCKETS
LOCTITE - SEALANTS & ADHESIVES
LOVEJOY - COUPLINGS
NRP JONES - HYDRAULIC HOSE & FITTINGS
MC GILL - BEARINGS AND CAM FOLLOWERS
PARKER - HYDRAULIC COMPONENTS
PRINCE MANUFACTURING - HYDRAULIC COMPONENTS
SKF - BEARINGS AND SEALS

SQUARE D - ELECTRICAL COMPONENTS
TNEMEC - PAINTS AND COATINGS
TOMPKINS - HYDRAULIC FITTINGS
TORRINGTON - BEARINGS & BEARING NUTS
TRADEMARK DESIGNS - NAME PLATES
WEATHERHEAD - HYDRAULIC HOSES AND FITTINGS
WHITEY - VALVES
WILDCAT RIDGE GEAR - GEARS, SPROCKETS, AND DRIVES

Introducing New Feature

NEW FEATURE VARIABLE CROWN - VC

WDM four roll machines are now available with a variable crown feature. This enables the operator to roll many types of material into true cylinders. This feature is used by companies rolling column covers of all sorts, sensitive long length cylinders for process components, and many other similar applications.

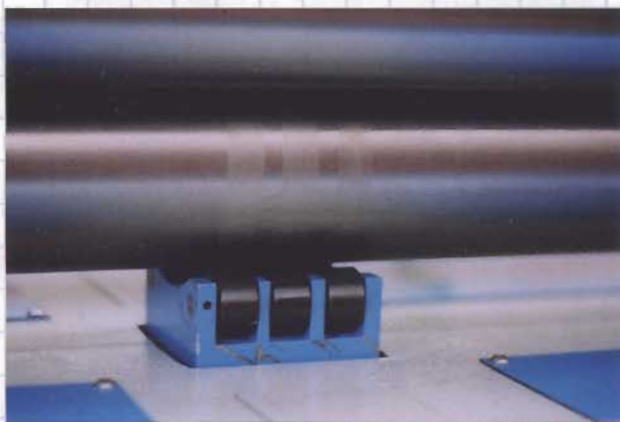

The crown adjustment rollers move simultaneously with the other lower roll support bearings.



Variable crown position is indicated via electronic digital readout. See photograph above.

Some Four-Roll Bending Systems



403-16-10 (57/64" x 10') with side and overhead supports used to manufacture silos and related parts for asphalt production.



403-6-8 (.140" x 8') with 1 side support, 1 overhead support, ejector, 421 digital readout with foot pedal. This machine is used to manufacture produce harvesting equipment.



403-12-10 (1/2" x 10') with side and overhead supports, swinging console control and 423-LP-6 control used for process and dust collection equipment.



403-7-5 (5/16" x 5') with Alpha 4 control.

Other Machines by...



REAL WORK HORSES
from Kentucky

403-29-10.5 (3" x 10.5') Four roll plate bending machine used for mining equipment fabrication.

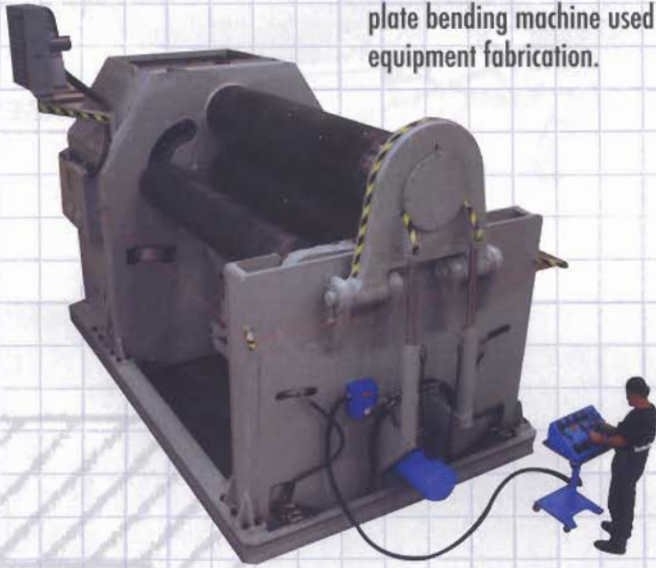

403 Series machine with special grooved rolls used in the dust collection equipment industry.



Pyramid roll with special grooves for rolling tank staves.



420 Series down rolling automatic plate roll used for forming automotive fuel tanks.



Special automatic cone roll for rolling concrete mixer drum sections. **Patent pending.**



Special three roll pinch pyramid with grooves for forming fan housings.

Even More Machines by...



Special built machine for forming fan blades.

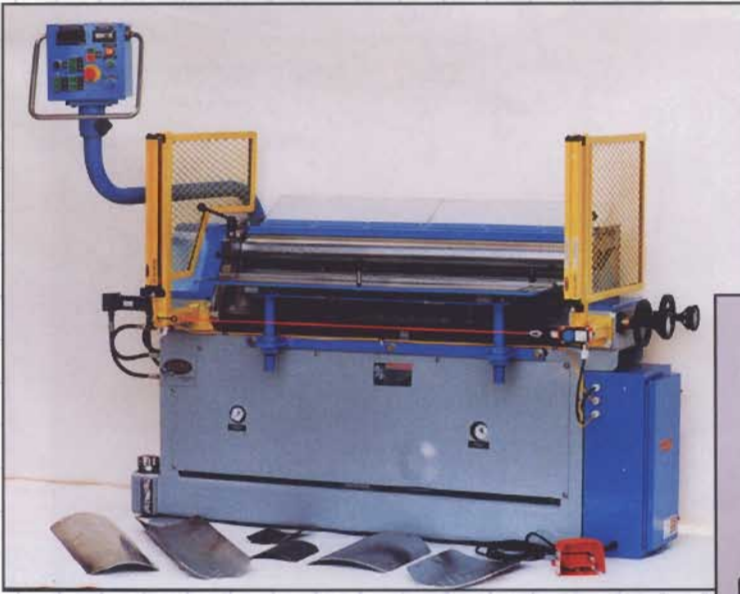

REAL WORK HORSES
from Kentucky

B-4-36 Sheet metal roll



K-5-10 (.048" x 10") with light curtain guarding.



400-5-5 (.135" x 5') with automatic feeder rolling D-shaped automotive fuel tanks automatically.

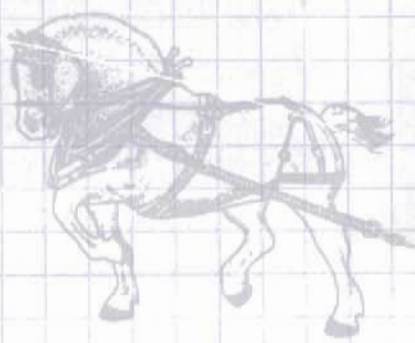

Machine to form titanium pins used for hip replacements.



Automatic round and oval forming machine used for ductwork in the HVAC industry.



K-6-6 (1/4" x 6") with optional foot pedal control.

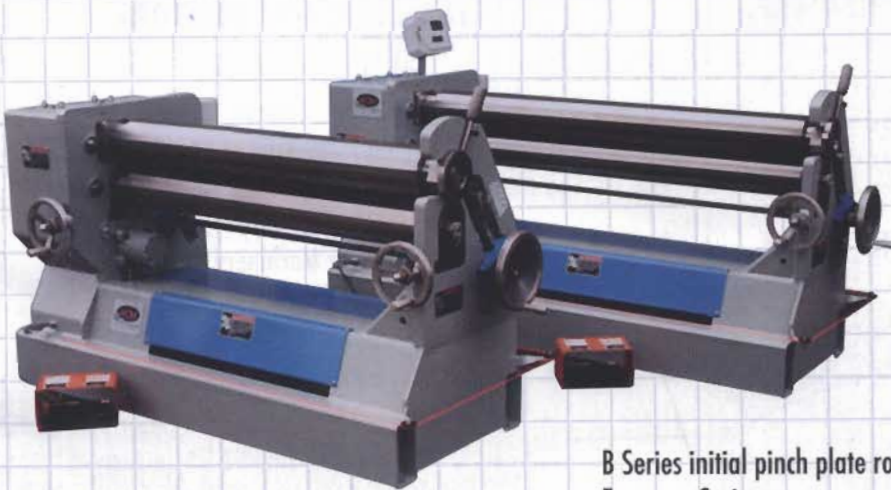

B Series initial pinch plate roll.
Economy Series.

Some Typical Four-Roll Machines

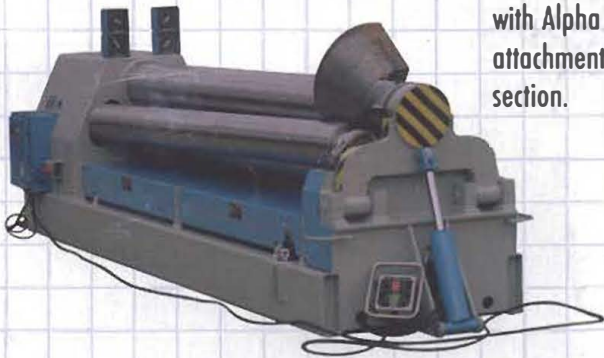

403-13-10 (19/32" x 10')
with Alpha 4 control and cone
attachment, rolling a cone
section.

403-7-5 (5/16" x 5') with 421
digital readout and special
grooved rolls.



403-8-6 (3/8" x 6') with 424 swinging
console control and foot pedal.



403-14-10 (11/16" x 10') with
swinging console control, 421
digital readout, and foot pedal.

MADE IN THE USA

For two generations the family business of Waldemar Design and Machine has been designing and manufacturing metal forming machines for industry small and large. We build these machines in a simple setting exercising serious craftsmanship and integrity. Many of the high quality components are manufactured in our shops in Kentucky, USA, or purchased from domestic or worldwide suppliers. Special attention is paid to quality, availability, and durability.

Your satisfaction and the performance of our machines is held in highest regard.

-Owners

PUBLIC NOTICE

Some Distributors including those listed sell WDM machines via the internet. WDM however does not, nor does it have a website or fax. You may reach us by phone, mail or courier. (We accept courier collect charges for urgent inquiries or drawings.)

ENGINEERING - MANUFACTURING - MAIN OFFICE

WALDEMAR DESIGN & MACHINE, LLC

1797 MATHERLY ROAD, LIBERTY, KY 42539 • 606-787-8474

Or contact your local machine tool distributor:

AHB
TOOLING & MACHINERY, INC.

COMPLETE
METALWORKING
SOLUTIONS

(800) 991-4225

www.ahbinc.com

ISO Certified

customerservice@ahbinc.com