

VacBOX 2200

Garnet Removal System

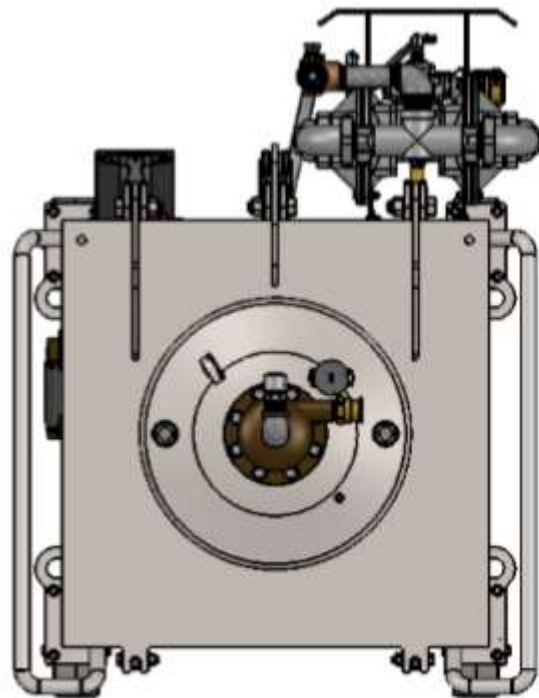
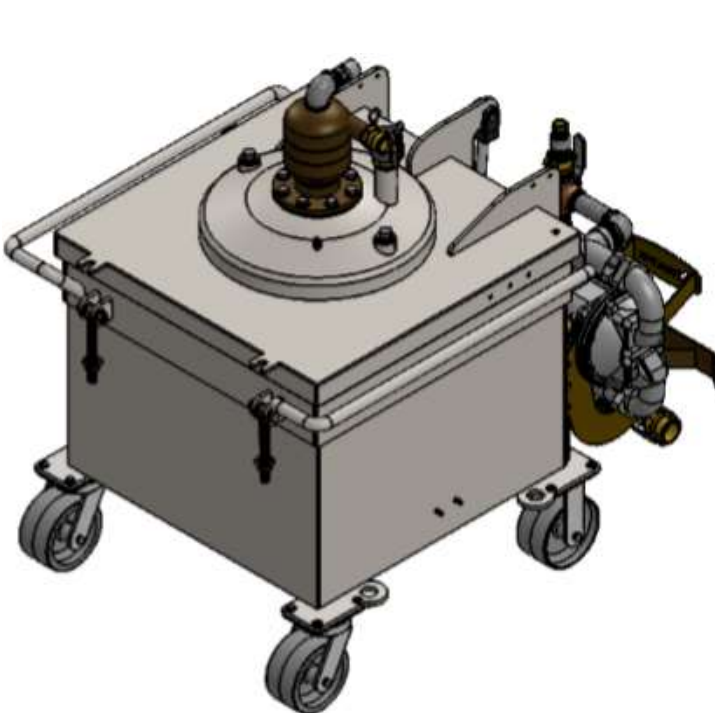
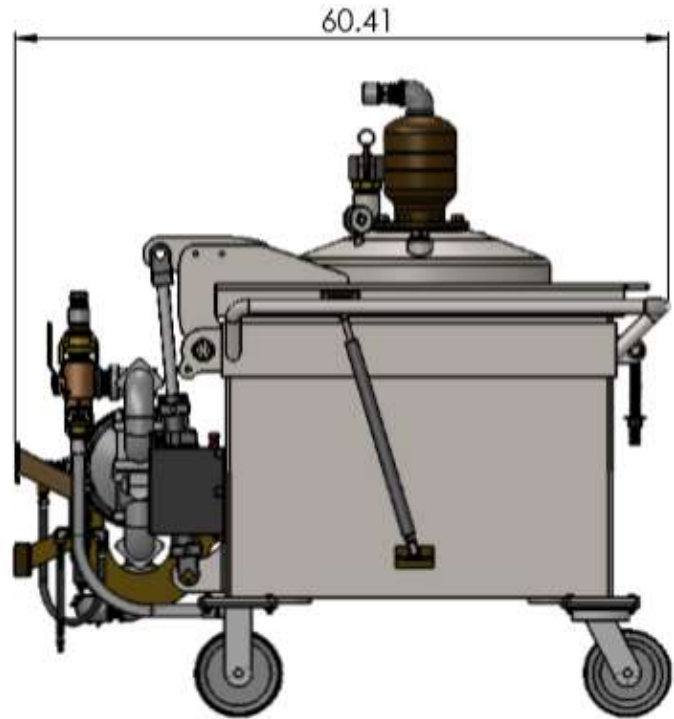
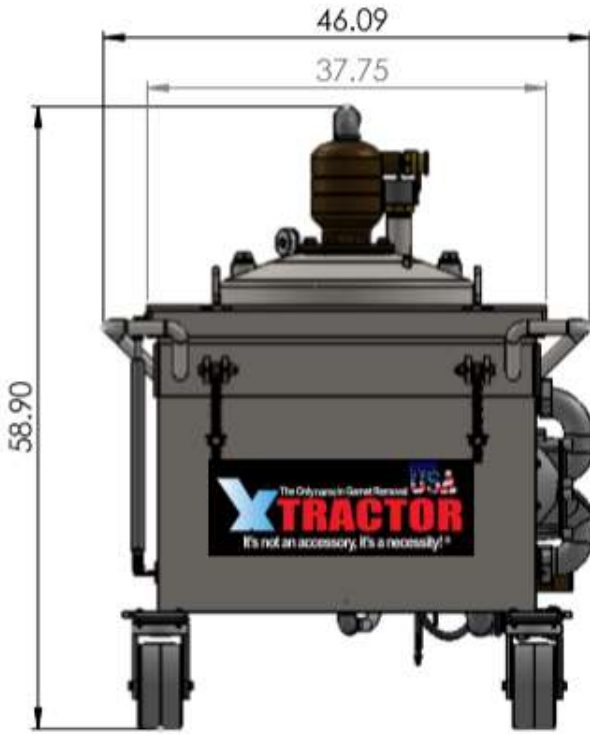

Complete Garnet Removal System Includes:

- Sandpiper HDF2 Diaphragm Pump
 - Up to 100 lbs./Minute garnet removal rate
 - 15.6 CFM at 60 PSI Air Requirements
- 10 Channel Radial Diffuser - 24" with Rotation Stopper
- Garnet Suction/Discharge Nozzle Assembly
- Suction Hose (1.5"x16') with Quick Release Brass CAM Lock Fittings
- Discharge Hose (1.5"x16') with Quick Release Brass CAM Lock Fittings
- Double Acting Hydraulic Hand Pump and 2500PSI 2"x10" Tie Rod Cylinder (to open and close lid)
- Dewatering Hose (1"x6') with Quick Release Brass CAM Lock Fitting and Debris Screen
- Choice of "Clean Garnet" (Regular) or "High Debris" (Extended) Suction Nozzle
- Garden Hose to Pump Flush Out Adapter
- 2 Fixed and 2 Swivel (1,100 lb.) castors for easy mobility
- QTY 4 – 2200 Bulk Bags (will hold over 8,000 lbs. of spent garnet)
- Full 1 Year Warranty

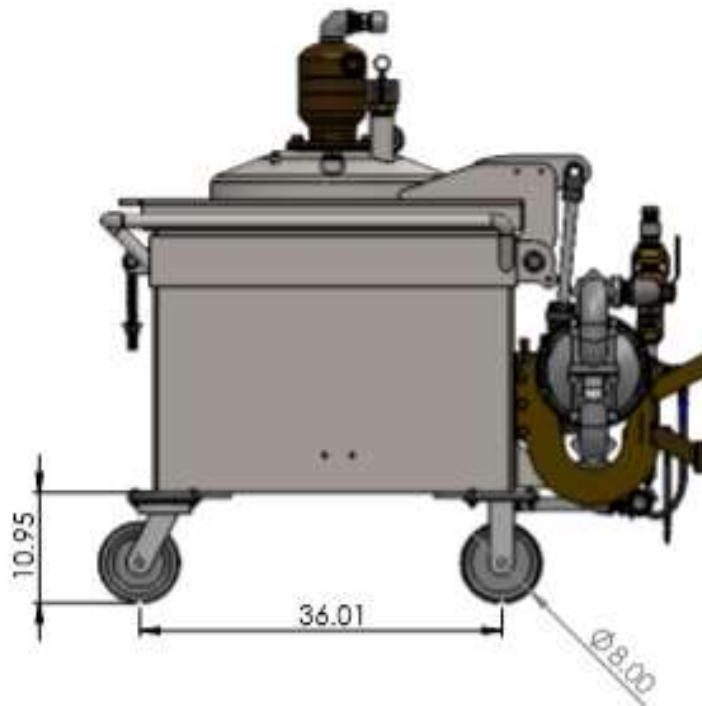

(800) 991-4225

www.ahbinc.com • customerservice@ahbinc.com

ISO Certified