

JUN. 2011

HIA SERIES

PARTS LIST

12781 HA400_400W(407L)(EU_EXP_DOM)

From Serial No. DOM:47722001 / EXP STD:45722001 / EXP W:45732001 / EU STD:44722001 / EU W:44732001 and after

Ver. 1.0

GENERAL INFORMATION

- * Specifications are subject to change without notice.
- * This parts list shows all of the parts used in your machine.
Please file this parts list for reference and refer to it when you order parts or maintain the machine.
- * This edition has been divided into sections.
Please refer to MACHINE COMPONENT.
- * The scale used on each page of drawings is different.
Please be aware that parts may seem to be different sizes on different pages.

INTRODUCTION

1. TABLE OF CONTENTS

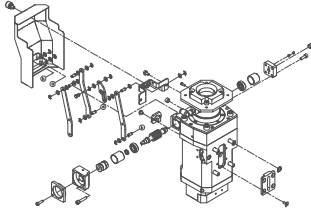
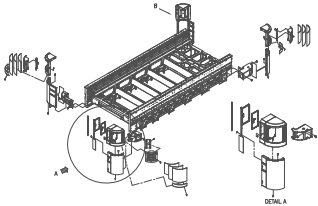
1	Head	2	Partition
			

- a Unit No.
- b Unit Name
- c Assembly drawings shown in the main text.

2. MAIN TEXT

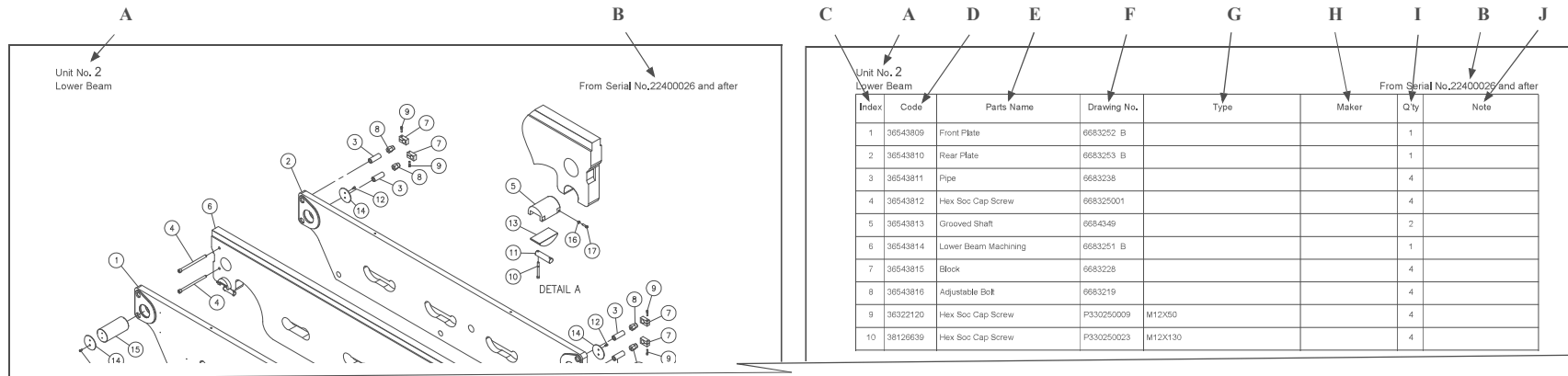

A Unit No. and Name

The Unit No. and Name are shown on relevant pages.

B Machine Serial No.

The Serial Nos. of machines corresponding to the information are shown.

C Index No.

The index No. for each part in a drawing is shown and corresponds to the list of parts for that drawing.

D Code

The individual Code No. for each part on the models is shown.

E Parts Name

The name (description) of each part.

F Drawing No.

The numbers of drawings relevant to the part are given.

G Type

The type description of each marketed item are shown.

H Maker

The manufacturer of each marketed item is shown.

I Quantity

The quantity of each part used on the models is shown.

J Notes

Cautions and notes necessary to the ordering each part.

ORDER INSTRUCTIONS

1. Confirm whether the model name and No. on the serial plate of the machine correspond to the numbers of the machines for which the parts list is effective.
2. Use the drawings in the Table of Contents to find the unit on which the part in question is shown in greater detail.
3. Spread out the referred pages.
4. Use the drawings and corresponding lists to confirm the specs, etc. of the part in question.
5. When ordering, please supply the following information:
 - (1)Machine Model
 - (2)Serial No.
 - (3)Code
 - (4)Quantity

UNIT LIST

Name Plate
Machine Body
Wedge-type Anchor Bolt
Drive Wheel Speed Reducer
Gearbox
Driven Wheel
Saw Blade Guide
Hydraulic
Swing Cylinder
Wire Brush
Cutting Fluid
Work Feeding Unit
Feed Cylinder
Vertical Roller
Rear Vise
Chip Conveyor
Work Light
Electric DOM
Electric US
Electric EU
Electric AS
Standard Accessory
Saw Blade Breakage Detection LS
Emergency Stop Button
Cover Open LS

Roller Stand
Roller Table
Option Accessory

//// Factory Options ////

Vise Pressure Control Valve
Float Switch
Signal Tower

//// Optional Accessories ////

Multi-vise

© 2011 AMADA CO., LTD.

All rights reserved. Printed in Japan.

MACHINE COMPONENT (1)

- Unit No.67 Electric DOM
- Unit No.71 Electric US
- Unit No.76 Electric EU
- Unit No.80 Electric AS
- Unit No.85-88 Standard Accessory
- Unit No.94 Roller Stand
- Unit No.101,102 Option Accessory

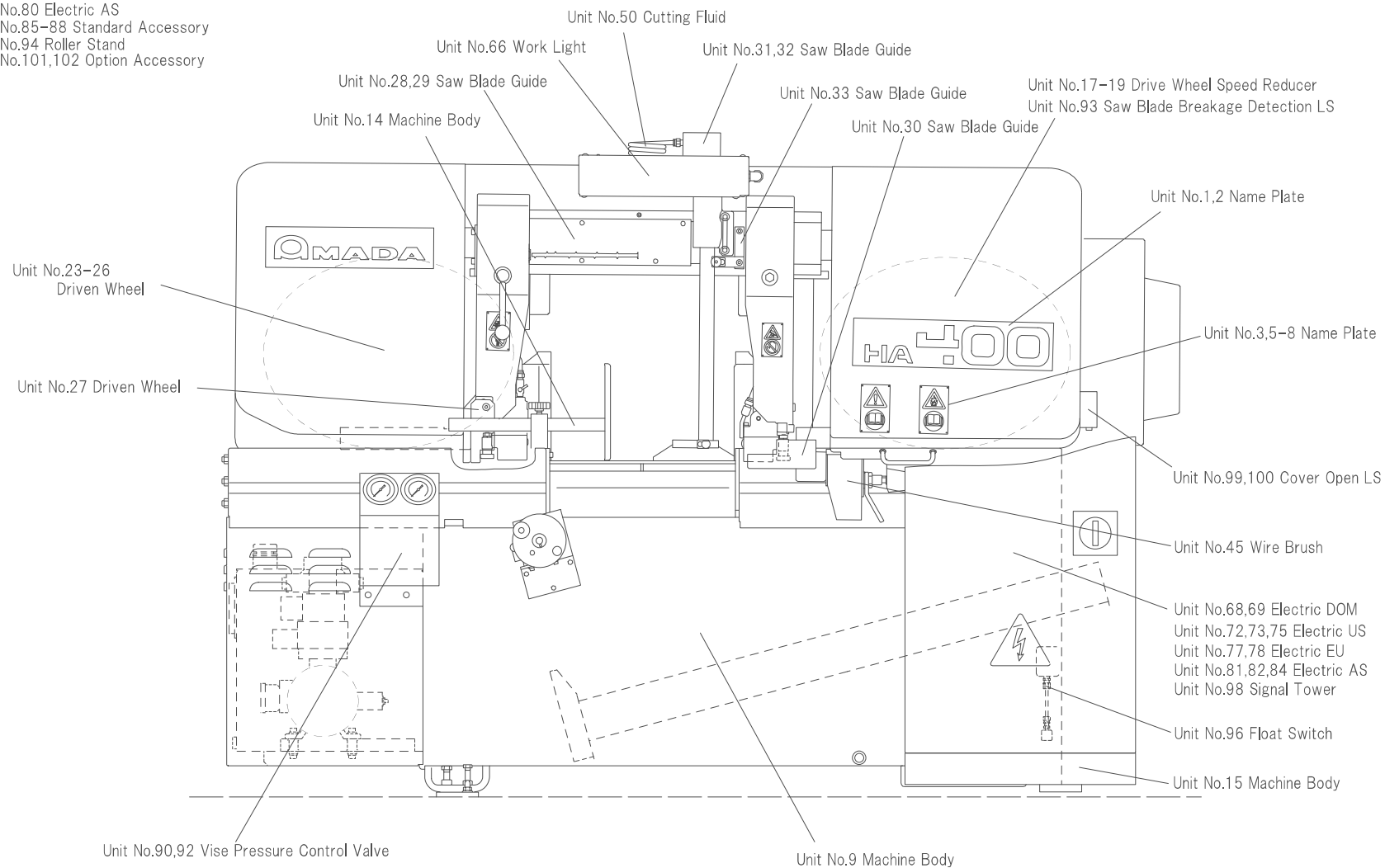

MACHINE COMPONENT (2)

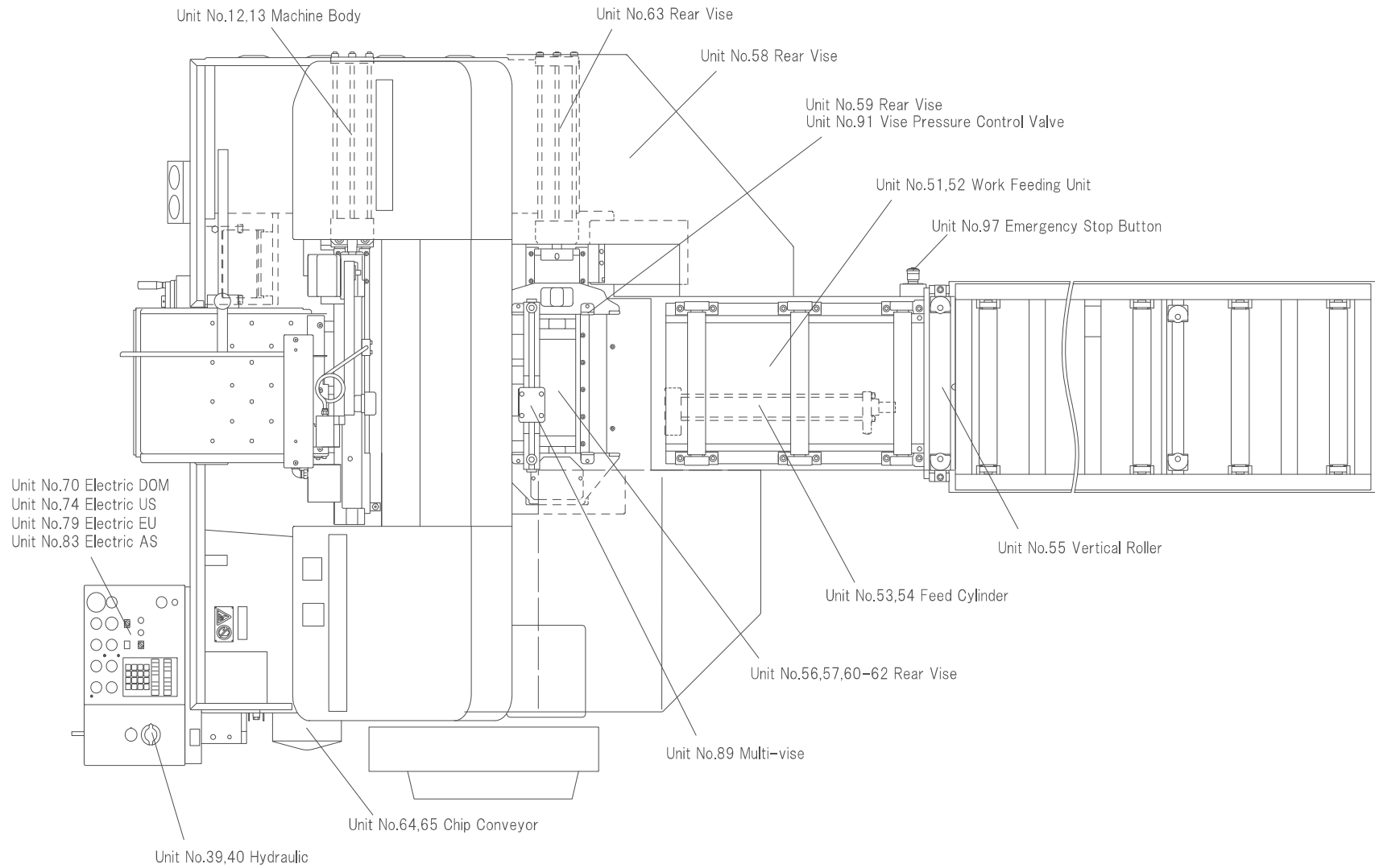

MACHINE COMPONENT (3)

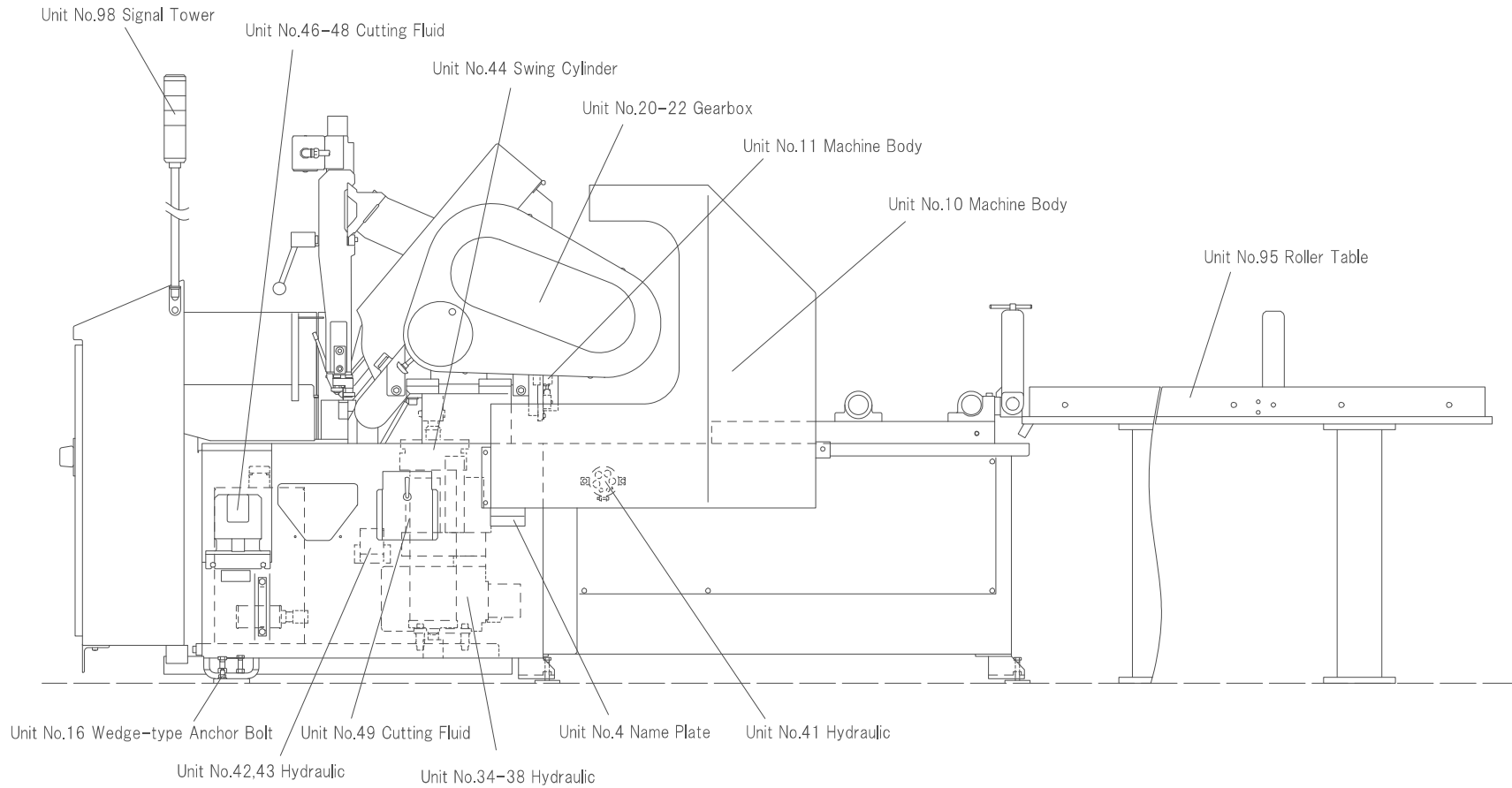

CONTENTS (1)

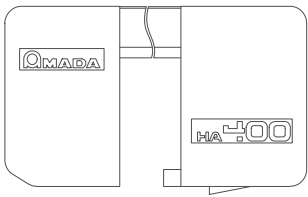
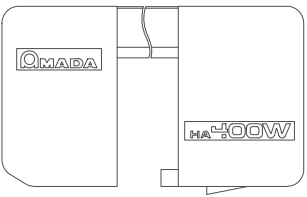
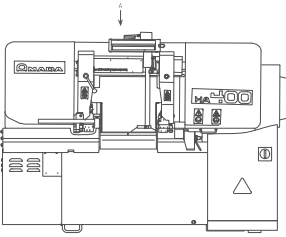
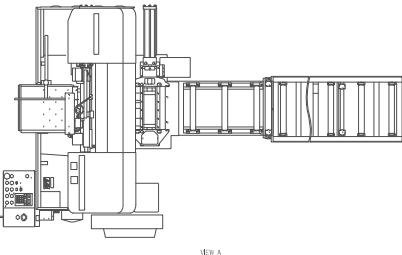
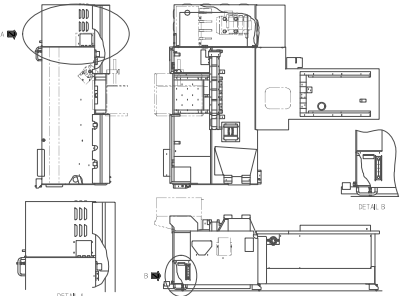
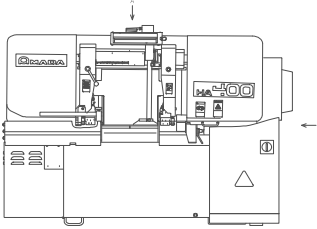
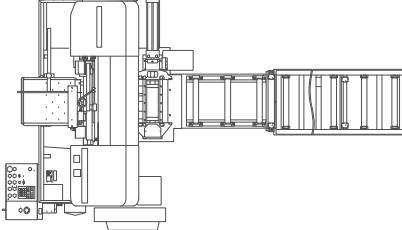
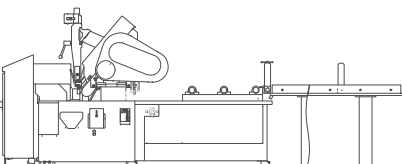
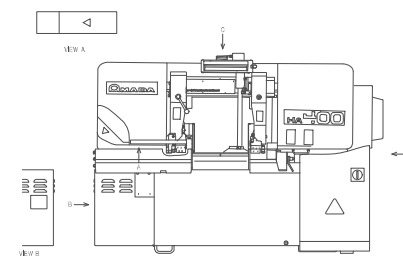
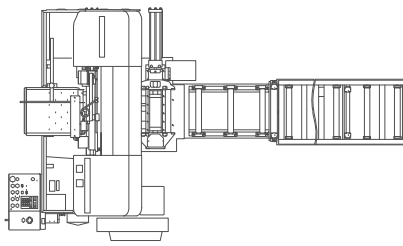
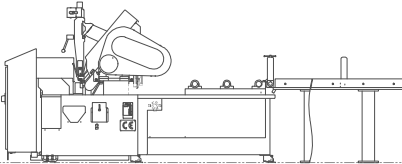
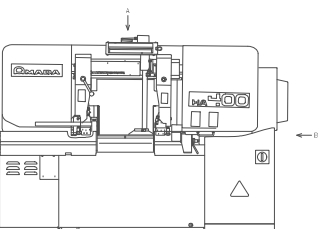
<p>1 Name Plate(1)</p> 	<p>2 Name Plate(2)</p> 	<p>3 Name Plate(3)-1/2</p> 	<p>3 Name Plate(3)-2/2</p> 
<p>4 Name Plate(4)</p> 	<p>5 Name Plate(5)-1/3</p> 	<p>5 Name Plate(5)-2/3</p> 	<p>5 Name Plate(5)-3/3</p> 
<p>6 Name Plate(6)-1/3</p> 	<p>6 Name Plate(6)-2/3</p> 	<p>6 Name Plate(6)-3/3</p> 	<p>7 Name Plate(7)-1/3</p> 

CONTENTS (2)

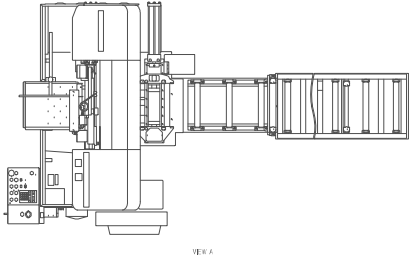
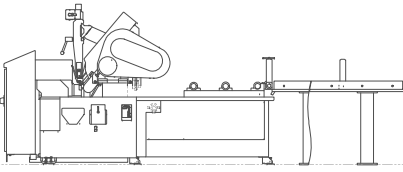
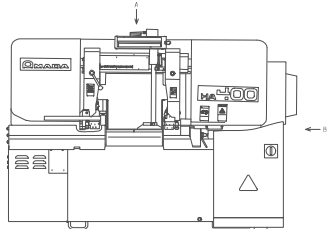
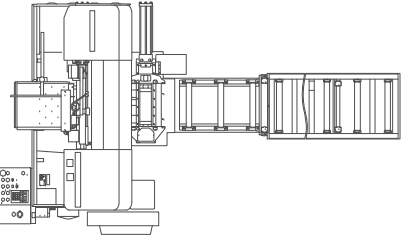
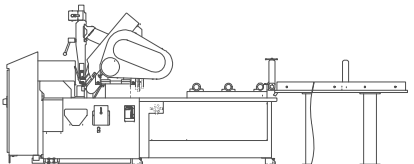
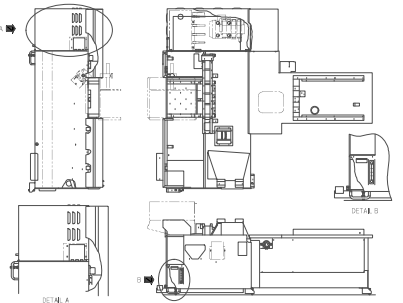
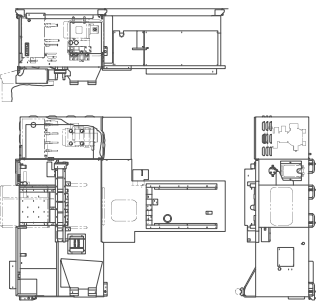
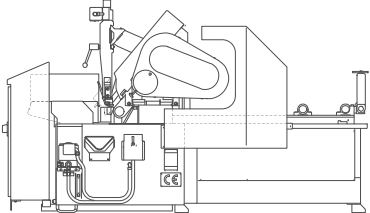
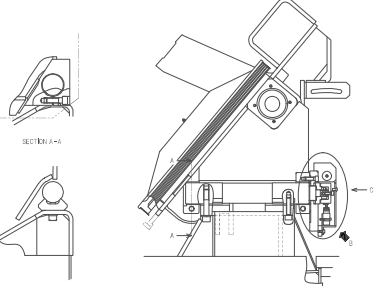
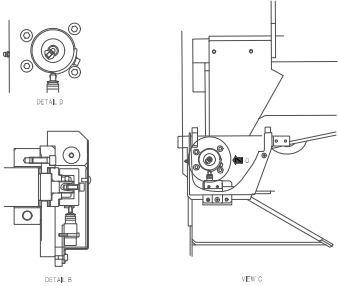
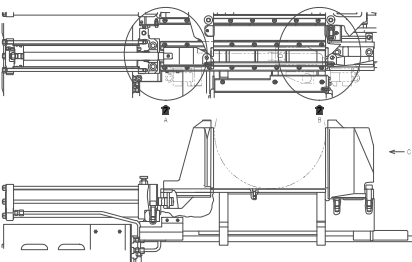
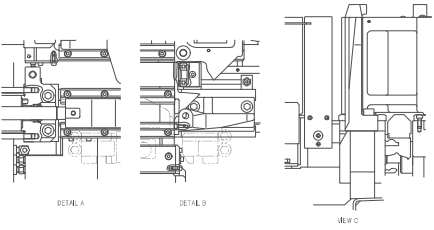
<p>7 Name Plate(7)-2/3</p>  <p>VIEW A</p>	<p>7 Name Plate(7)-3/3</p>  <p>VIEW B</p>	<p>8 Name Plate(8)-1/3</p>  <p>VIEW A</p>	<p>8 Name Plate(8)-2/3</p>  <p>VIEW A</p>
<p>8 Name Plate(8)-3/3</p>  <p>VIEW B</p>	<p>9 Machine Body(1)-1/2</p>  <p>DETAIL A DETAIL B</p>	<p>9 Machine Body(1)-2/2</p>  <p>DETAIL B</p>	<p>10 Machine Body(2)</p>  <p>VIEW B</p>
<p>11 Machine Body(3)-1/2</p>  <p>SECTION A-B DETAIL B</p>	<p>11 Machine Body(3)-2/2</p>  <p>DETAIL B VIEW C</p>	<p>12 Machine Body(4)-1/2</p>  <p>DETAIL B VIEW C</p>	<p>12 Machine Body(4)-2/2</p>  <p>DETAIL A DETAIL B VIEW C</p>

CONTENTS (3)

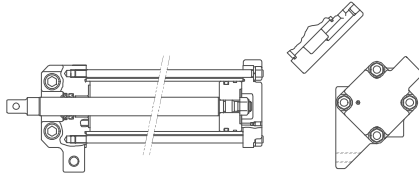
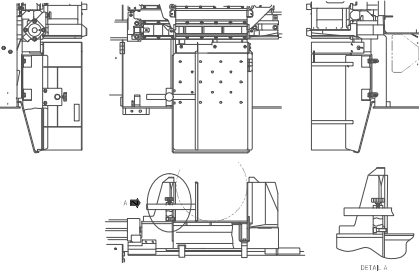
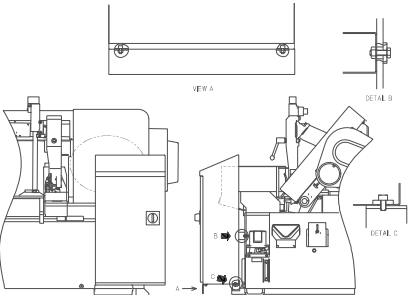
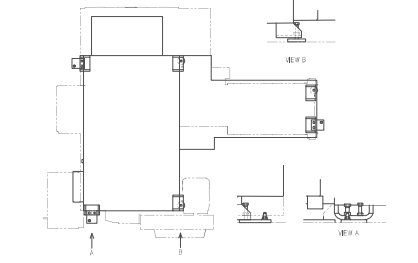
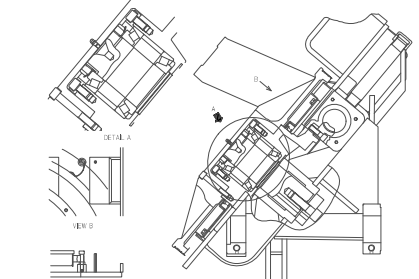
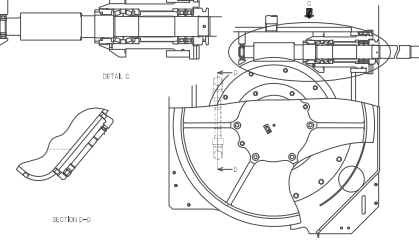
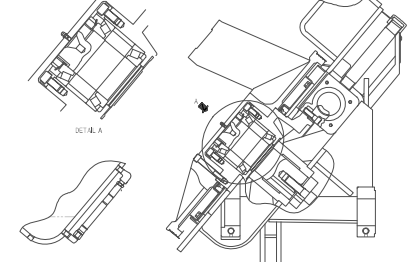
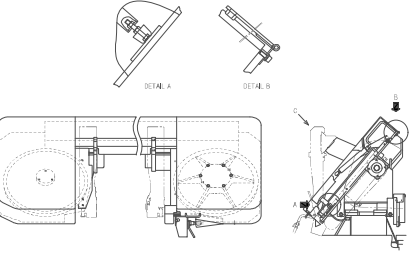
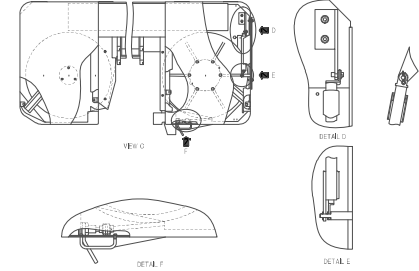
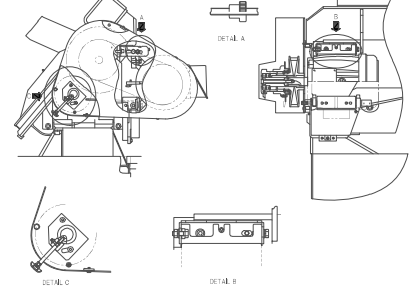
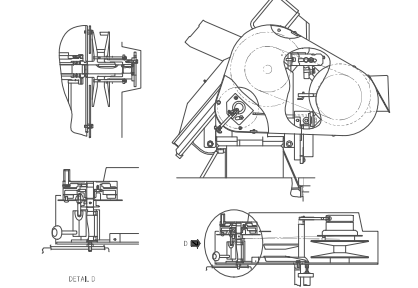
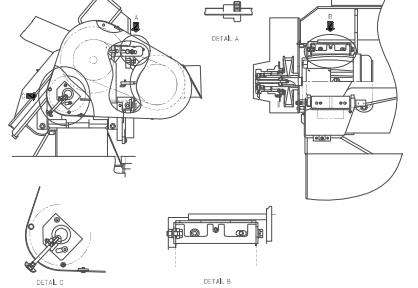
<p>13 Machine Body(5)</p> 	<p>14 Machine Body(6)</p> 	<p>15 Machine Body(7)</p> 	<p>16 Wedge-type Anchor Bolt</p> 
<p>17 Drive Wheel Speed Reducer(1)-1/2</p> 	<p>17 Drive Wheel Speed Reducer(1)-2/2</p> 	<p>18 Drive Wheel Speed Reducer(2)</p> 	<p>19 Drive Wheel Speed Reducer(3)-1/2</p> 
<p>19 Drive Wheel Speed Reducer(3)-2/2</p> 	<p>20 Gearbox(1)-1/2</p> 	<p>20 Gearbox(1)-2/2</p> 	<p>21 Gearbox(2)</p> 

CONTENTS (4)

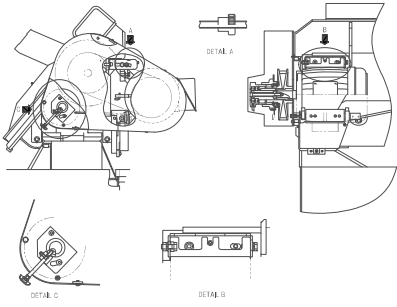
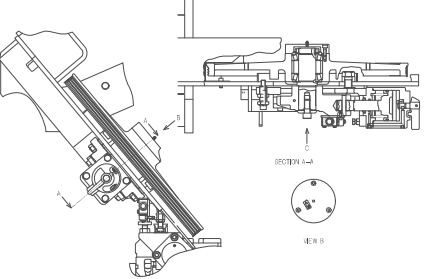
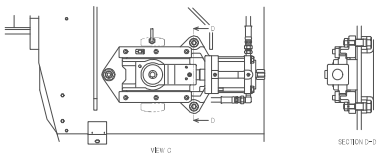
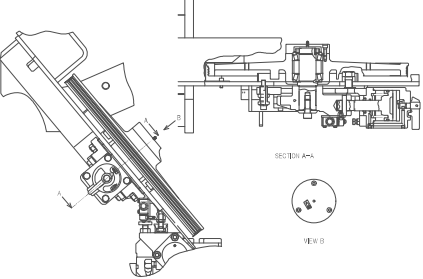
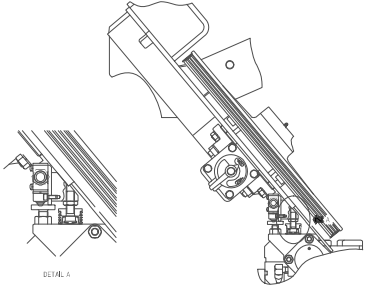
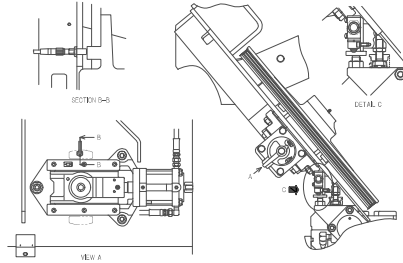
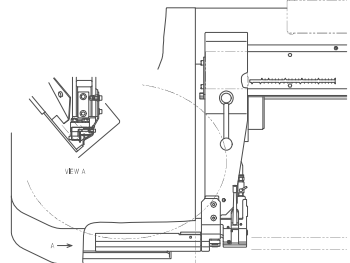
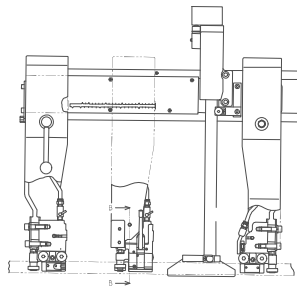
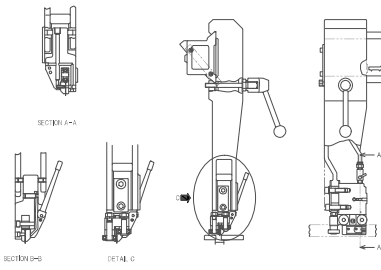
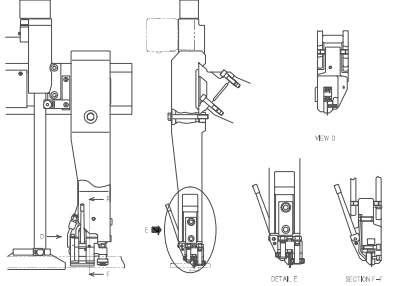
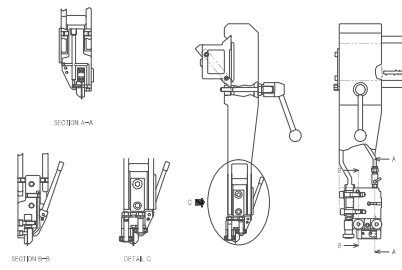
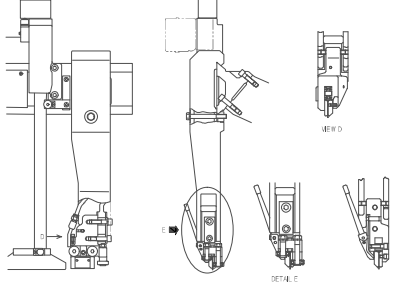
<p>22 Gearbox(3)</p> 	<p>23 Driven Wheel(1)-1/2</p> 	<p>23 Driven Wheel(1)-2/2</p> 	<p>24 Driven Wheel(2)</p> 
<p>25 Driven Wheel(3)</p> 	<p>26 Driven Wheel(4)</p> 	<p>27 Driven Wheel(5)</p> 	<p>28 Saw Blade Guide(1)-1/3</p> 
<p>28 Saw Blade Guide(1)-2/3</p> 	<p>28 Saw Blade Guide(1)-3/3</p> 	<p>29 Saw Blade Guide(2)-1/2</p> 	<p>29 Saw Blade Guide(2)-2/2</p> 

CONTENTS (5)

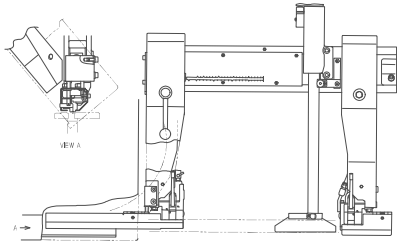
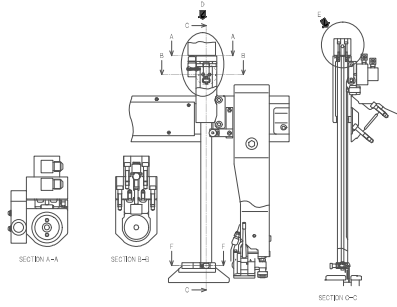
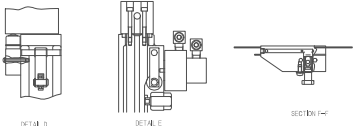
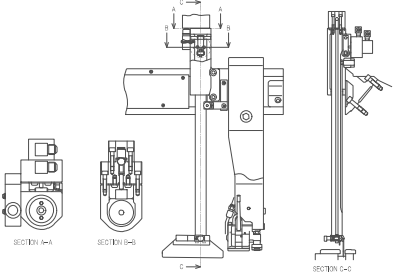
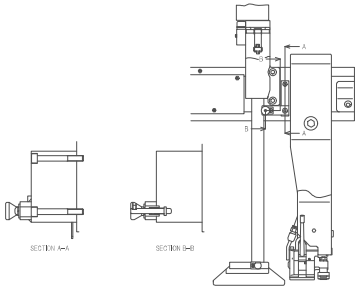
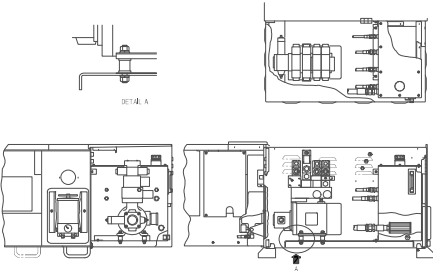
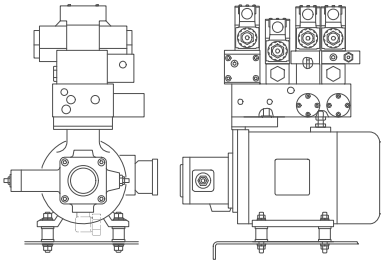
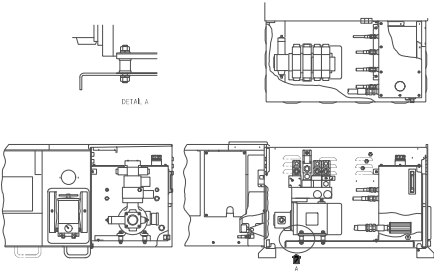
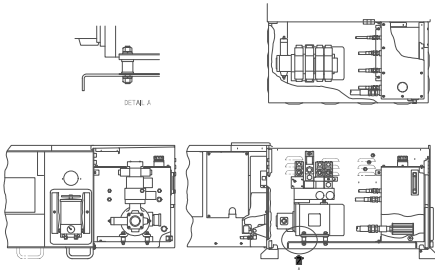
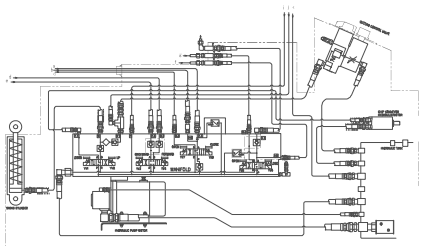
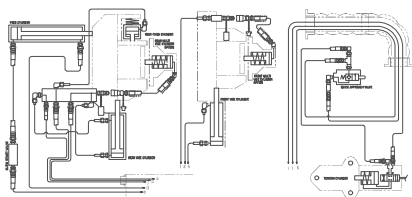
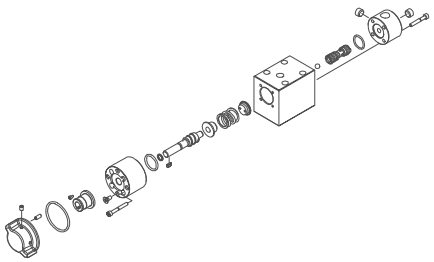
<p>30 Saw Blade Guide(3)</p> 	<p>31 Saw Blade Guide(4)-1/2</p> 	<p>31 Saw Blade Guide(4)-2/2</p> 	<p>32 Saw Blade Guide(5)</p> 
<p>33 Saw Blade Guide(6)</p> 	<p>34 Hydraulic(1)</p> 	<p>35 Hydraulic(2)</p> 	<p>36 Hydraulic(3)</p> 
<p>37 Hydraulic(4)</p> 	<p>38 Hydraulic(5)-1/2</p> 	<p>38 Hydraulic(5)-2/2</p> 	<p>39 Hydraulic(6)</p> 

CONTENTS (6)

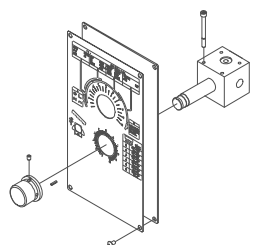
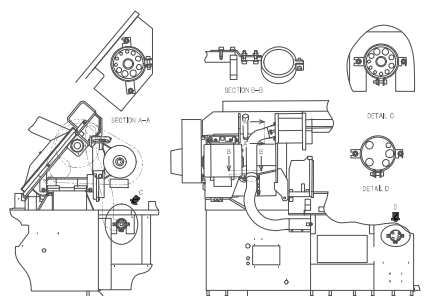
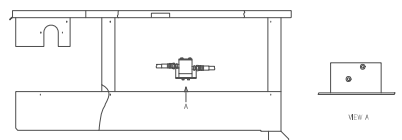
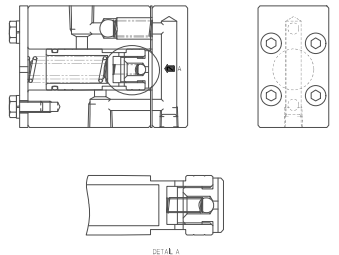
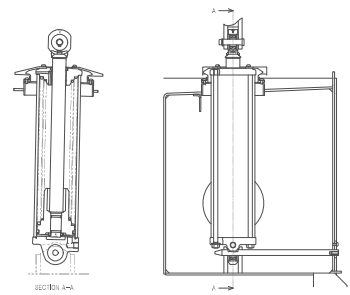
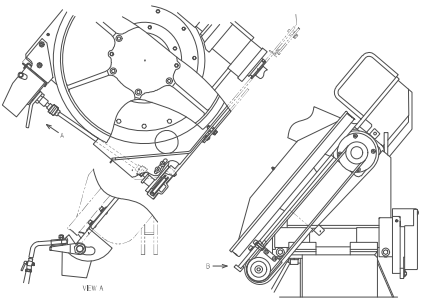
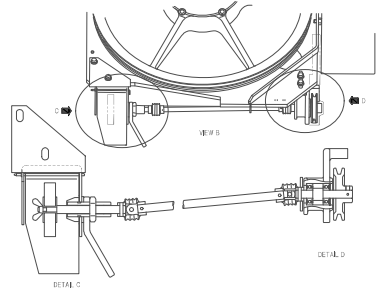
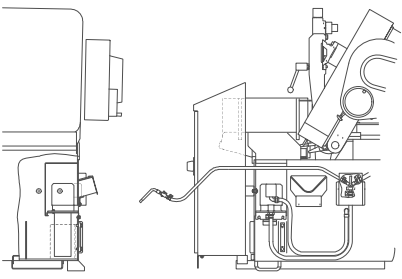
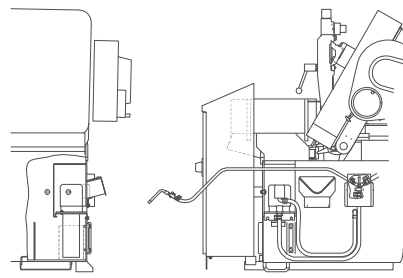
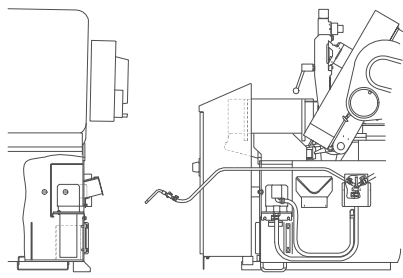
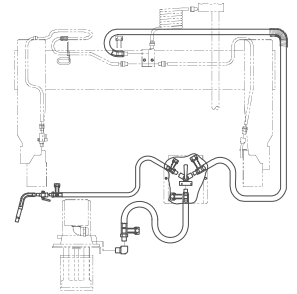
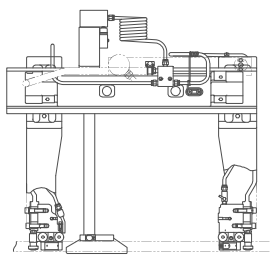
<p>40 Hydraulic(7)</p>	<p>41 Hydraulic(8)</p>	<p>42 Hydraulic(9)</p>	<p>43 Hydraulic(10)</p>
			
<p>44 Swing Cylinder</p>	<p>45 Wire Brush-1/2</p>	<p>45 Wire Brush-2/2</p>	<p>46 Cutting Fluid(1)</p>
			
<p>47 Cutting Fluid(2)</p>	<p>48 Cutting Fluid(3)</p>	<p>49 Cutting Fluid(4)</p>	<p>50 Cutting Fluid(5)</p>
			

CONTENTS (7)

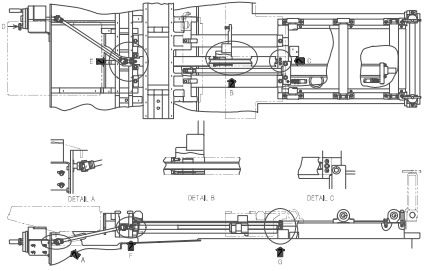
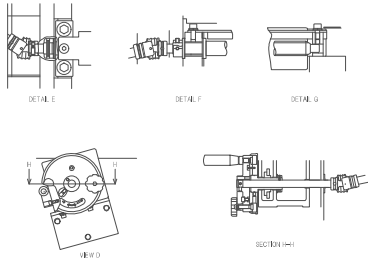
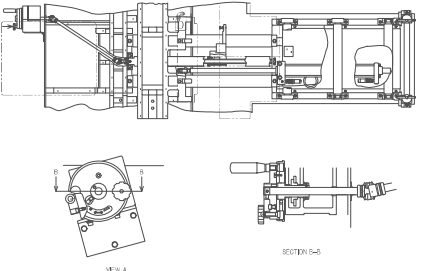
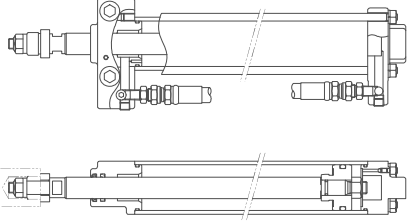
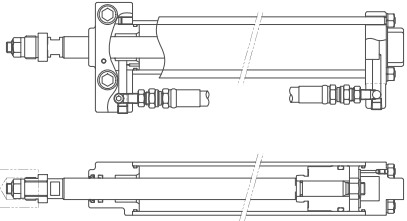
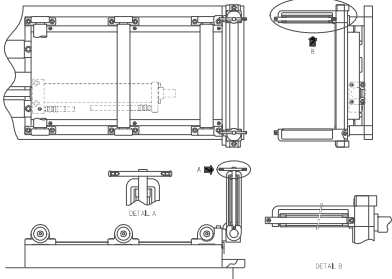
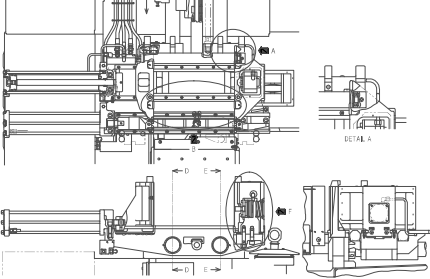
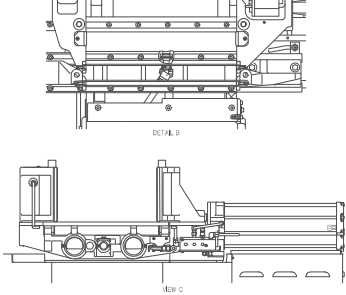
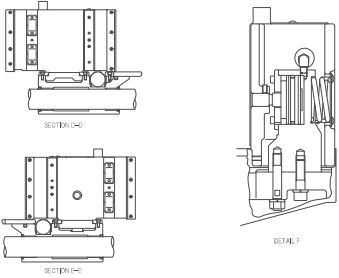
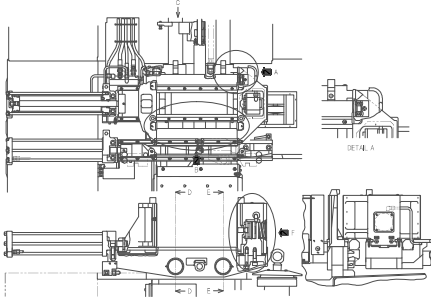
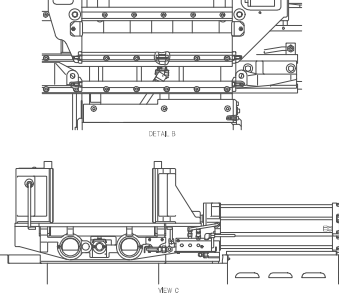
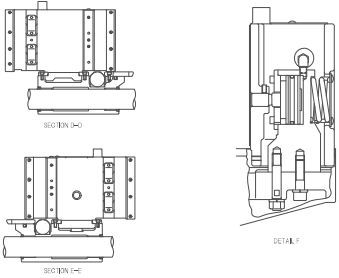
<p>51 Work Feeding Unit(1)-1/2</p> 	<p>51 Work Feeding Unit(1)-2/2</p> 	<p>52 Work Feeding Unit(2)</p> 	<p>53 Feed Cylinder(1)</p> 
<p>54 Feed Cylinder(2)</p> 	<p>55 Vertical Roller</p> 	<p>56 Rear Vise(1)-1/3</p> 	<p>56 Rear Vise(1)-2/3</p> 
<p>56 Rear Vise(1)-3/3</p> 	<p>57 Rear Vise(2)-1/3</p> 	<p>57 Rear Vise(2)-2/3</p> 	<p>57 Rear Vise(2)-3/3</p> 

CONTENTS (8)

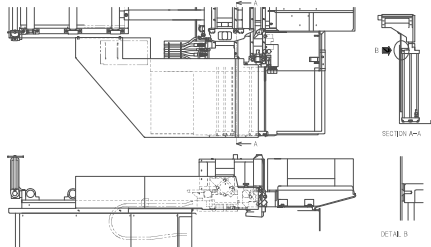
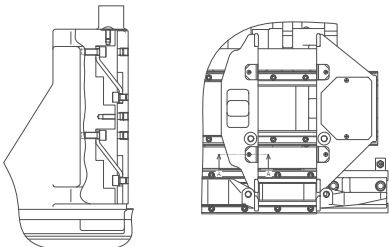
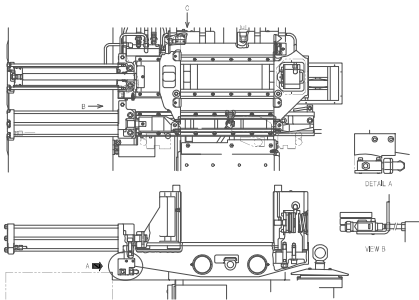
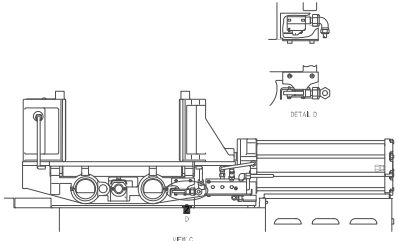
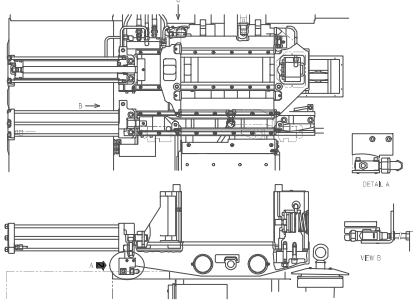
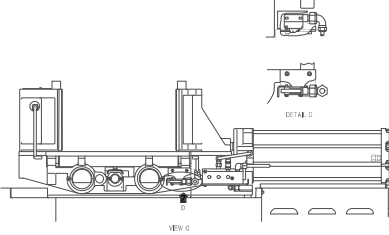
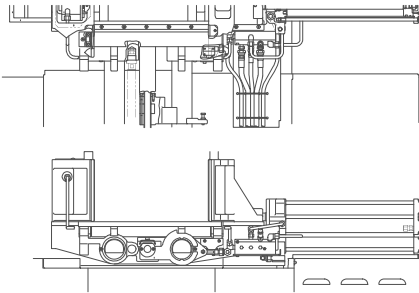
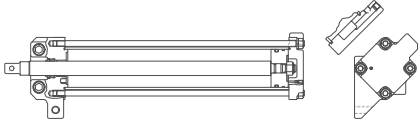
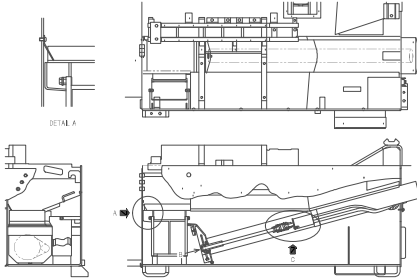
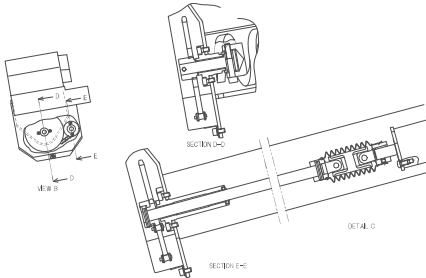
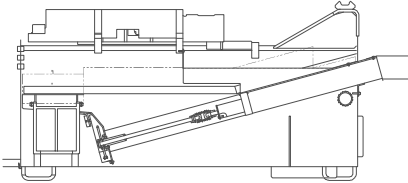
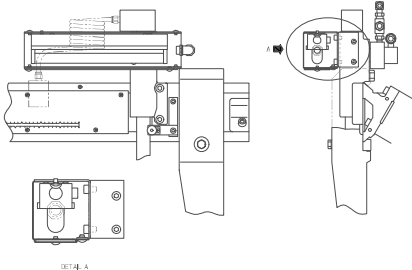
<p>58 Rear Vise(3)</p> 	<p>59 Rear Vise(4)</p> 	<p>60 Rear Vise(5)-1/2</p> 	<p>60 Rear Vise(5)-2/2</p> 
<p>61 Rear Vise(6)-1/2</p> 	<p>61 Rear Vise(6)-2/2</p> 	<p>62 Rear Vise(7)</p> 	<p>63 Rear Vise(8)</p> 
<p>64 Chip Conveyor(1)-1/2</p> 	<p>64 Chip Conveyor(1)-2/2</p> 	<p>65 Chip Conveyor(2)</p> 	<p>66 Work Light</p> 

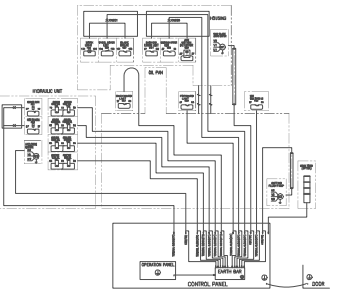
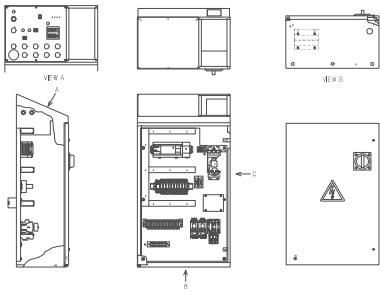
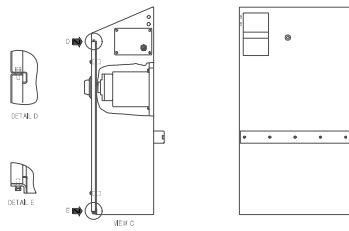
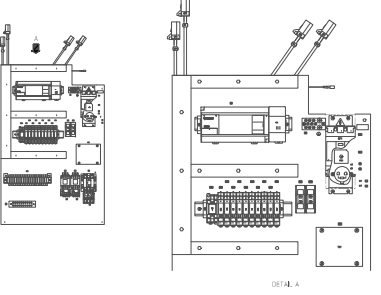
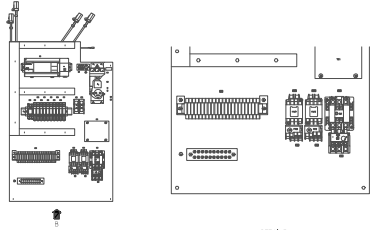
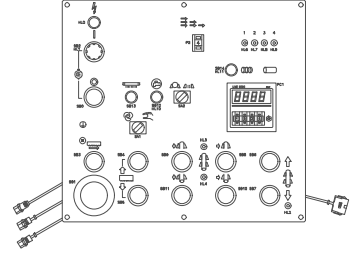
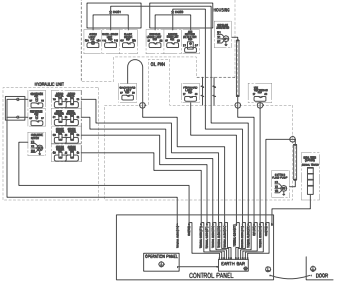
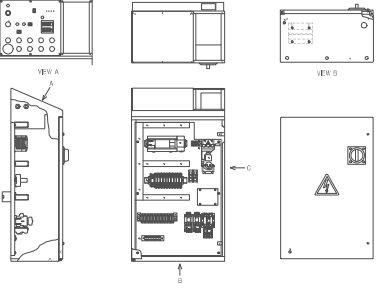
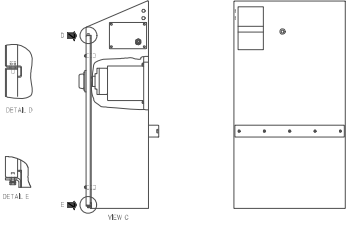
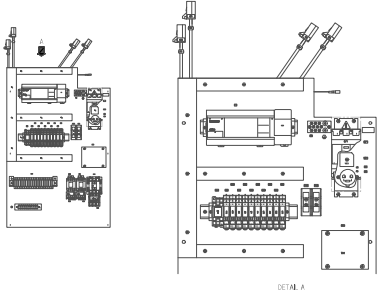
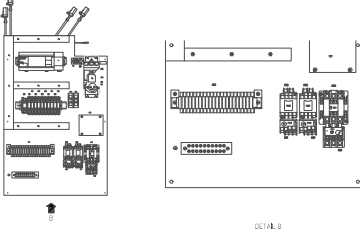
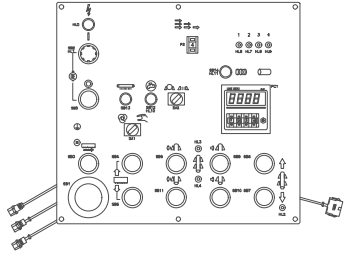

CONTENTS (9)

<p>67 Electric DOM(1)</p> 	<p>68 Electric DOM(2)-1/2</p> 	<p>68 Electric DOM(2)-2/2</p> 	<p>69 Electric DOM(3)-1/2</p> 
<p>69 Electric DOM(3)-2/2</p> 	<p>70 Electric DOM(4)</p> 	<p>71 Electric US(1)</p> 	<p>72 Electric US(2)-1/2</p> 
<p>72 Electric US(2)-2/2</p> 	<p>73 Electric US(3)-1/2</p> 	<p>73 Electric US(3)-2/2</p> 	<p>74 Electric US(4)</p> 

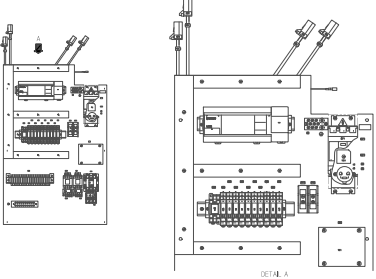
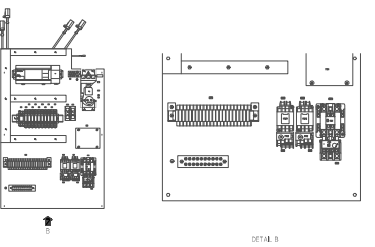
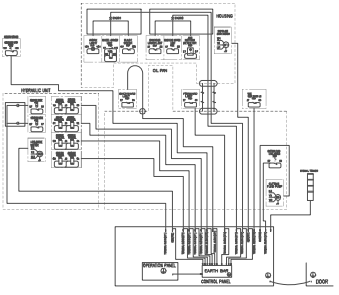
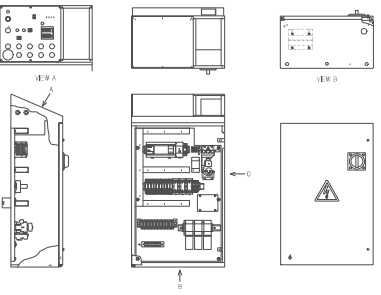
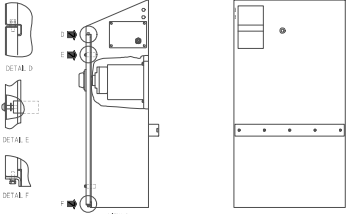
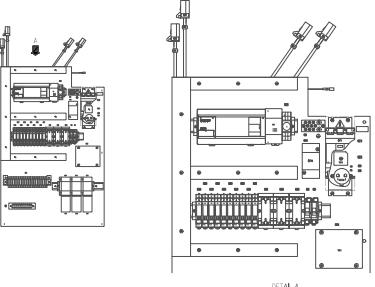
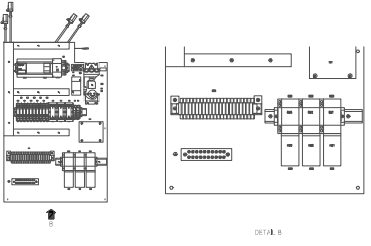
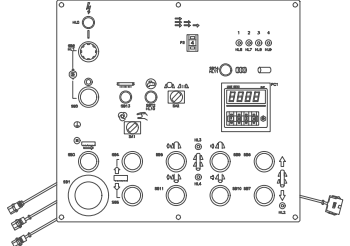
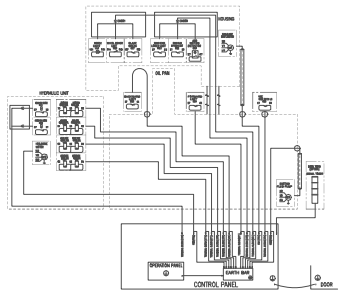
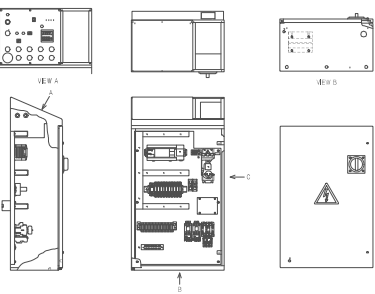
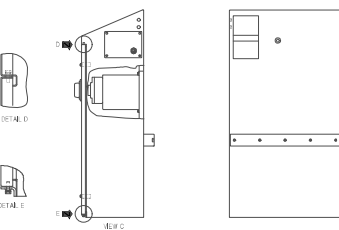
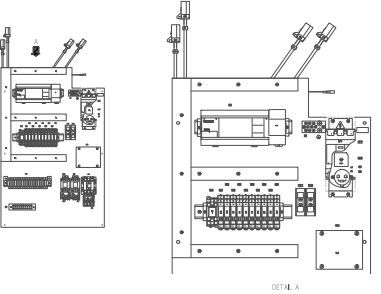
CONTENTS (10)

<p>75 Electric US(5)-1/2</p> 	<p>75 Electric US(5)-2/2</p> 	<p>76 Electric EU(1)</p> 	<p>77 Electric EU(2)-1/2</p> 
<p>77 Electric EU(2)-2/2</p> 	<p>78 Electric EU(3)-1/2</p> 	<p>78 Electric EU(3)-2/2</p> 	<p>79 Electric EU(4)</p> 
<p>80 Electric AS(1)</p> 	<p>81 Electric AS(2)-1/2</p> 	<p>81 Electric AS(2)-2/2</p> 	<p>82 Electric AS(3)-1/2</p> 

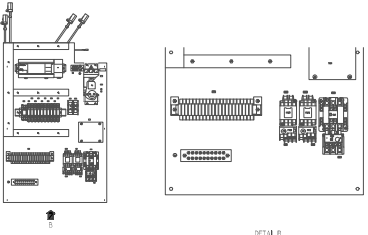
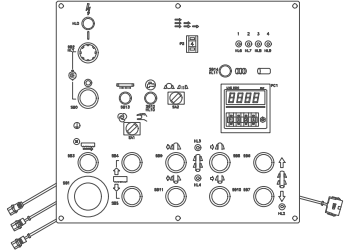
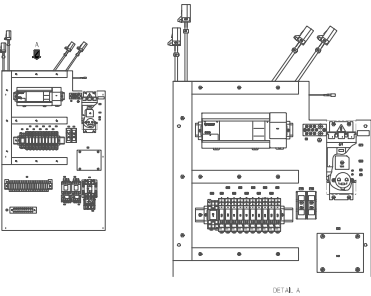
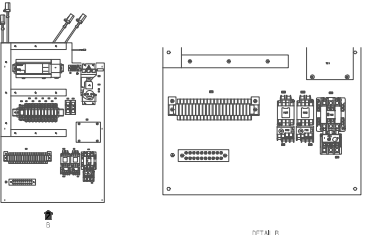
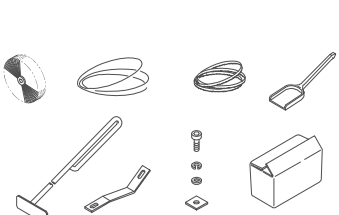
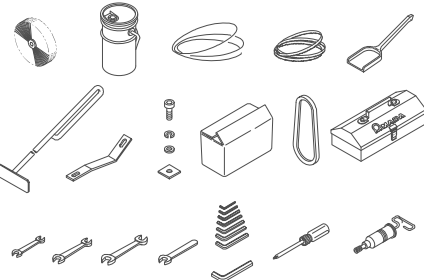
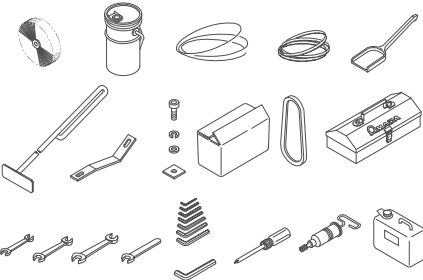
CONTENTS (11)

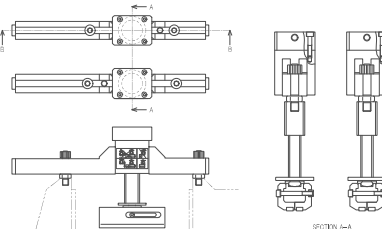
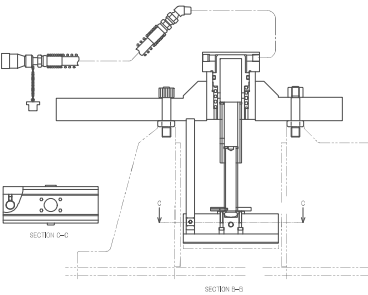
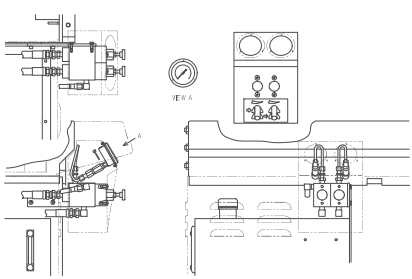
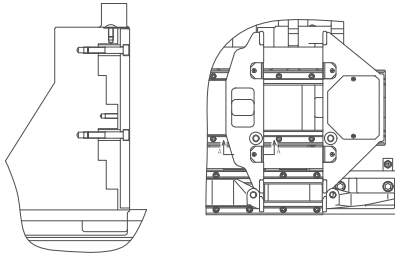
<p>82 Electric AS(3)-2/2</p> 	<p>83 Electric AS(4)</p> 	<p>84 Electric AS(5)-1/2</p> 	<p>84 Electric AS(5)-2/2</p> 
<p>85 Standard Accessory(1)</p> 	<p>86 Standard Accessory(2)</p> 	<p>87 Standard Accessory(3)</p> 	<p>88 Standard Accessory(4)</p> 
<p>89 Multi-vise-1/2</p> 	<p>89 Multi-vise-2/2</p> 	<p>90 Vise Pressure Control Valve(1)</p> 	<p>91 Vise Pressure Control Valve(2)</p> 

CONTENTS (12)

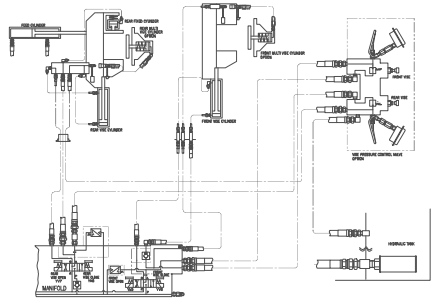
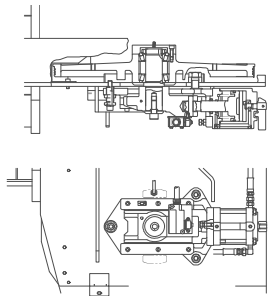
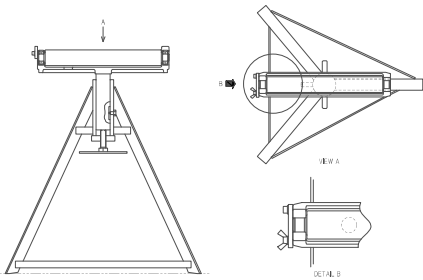
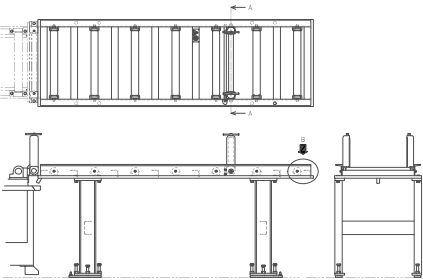
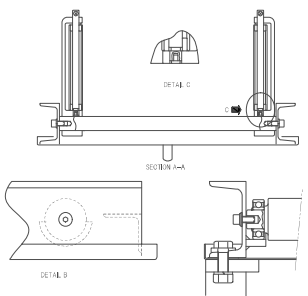
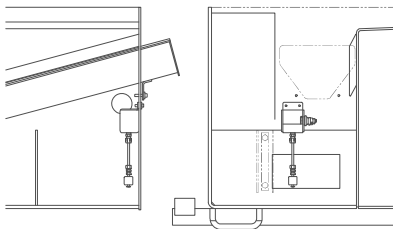
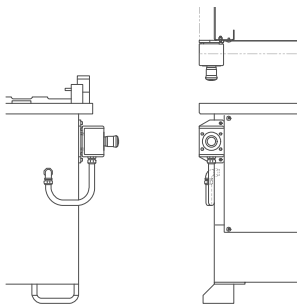
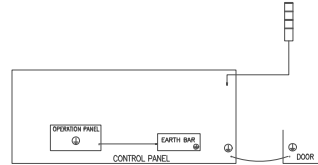
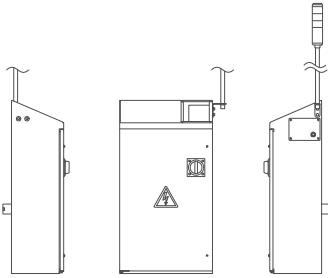
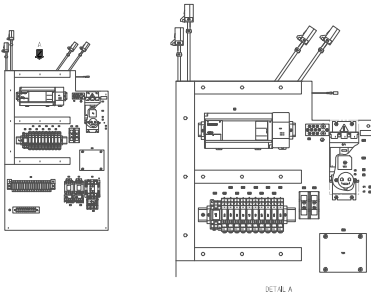
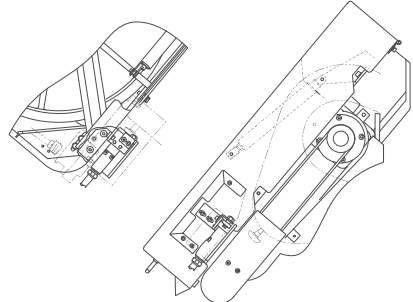
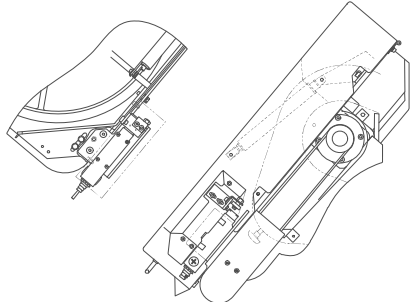
<p>92 Vise Pressure Control Valve(3)</p>	<p>93 Saw Blade Breakage Detection LS</p>	<p>94 Roller Stand</p>	<p>95 Roller Table-1/2</p>
			
<p>95 Roller Table-2/2</p>	<p>96 Float Switch</p>	<p>97 Emergency Stop Button</p>	<p>98 Signal Tower-1/3</p>
			
<p>98 Signal Tower-2/3</p>	<p>98 Signal Tower-3/3</p>	<p>99 Cover Open LS(1)</p>	<p>100 Cover Open LS(2)</p>
			

CONTENTS (13)

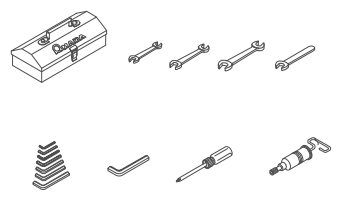
101	Option Accessory(1)	102	Option Accessory(2)	
				

Unit No. 1
Name Plate(1)

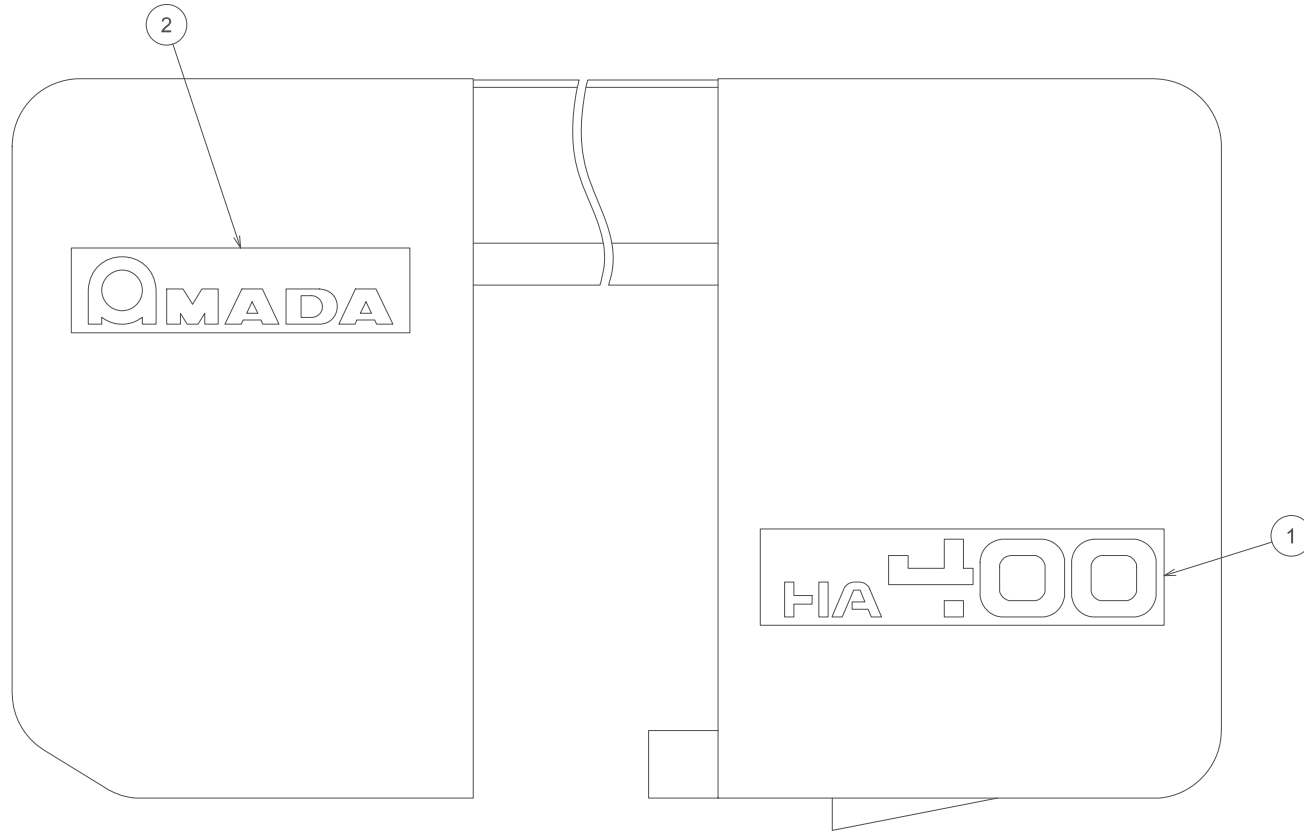

1278799--A
(1278811--A)

Unit No. 1
Name Plate(1)

Index	Code	Parts Name	Drawing No.	Type	Maker	Q'ty	Note
1	10301446	Model Plate	RB01816--A			1	
2	10300442	Amada Plate	RB00368---			1	

Unit No. 2
Name Plate(2) <HA400W>

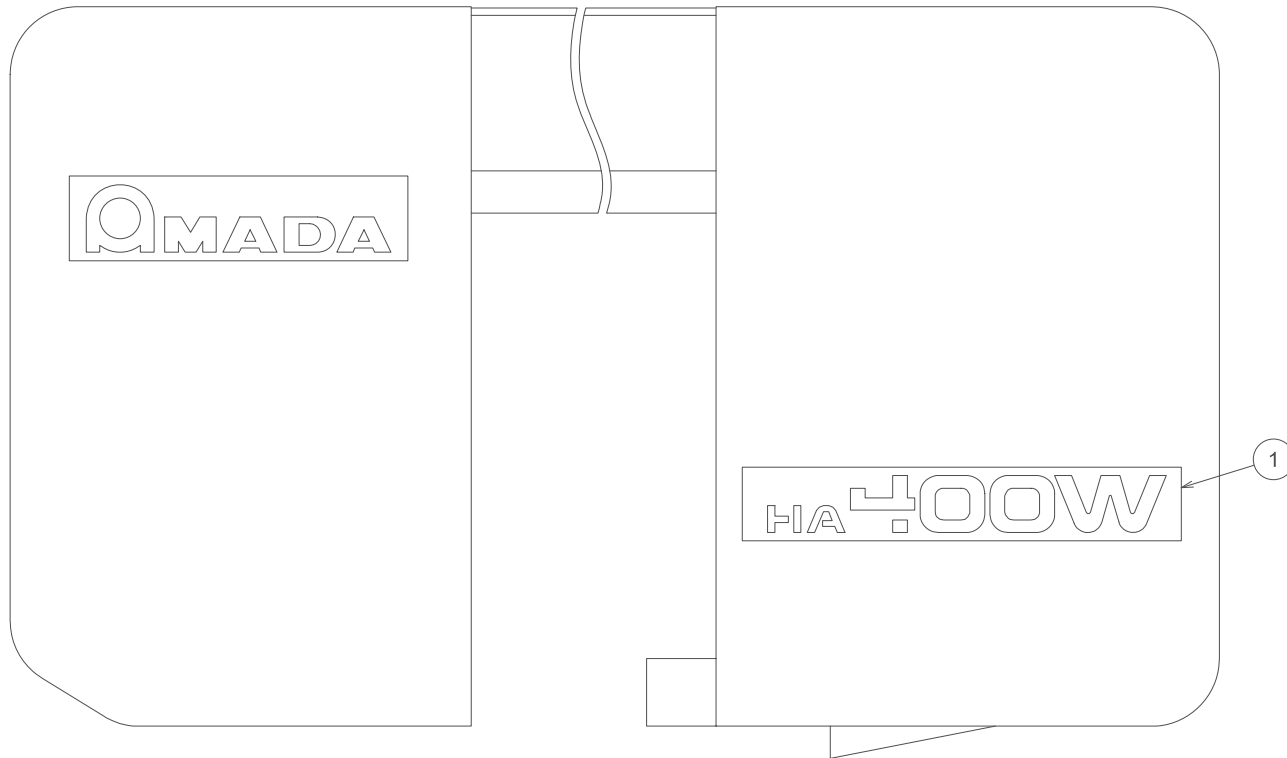

Unit No. 2
Name Plate(2)

Index	Code	Parts Name	Drawing No.	Type	Maker	Q'ty	Note
1	10301511	Model Plate	RB02378---			1	

Unit No. 3
Name Plate(3)-1/2 <DOM>

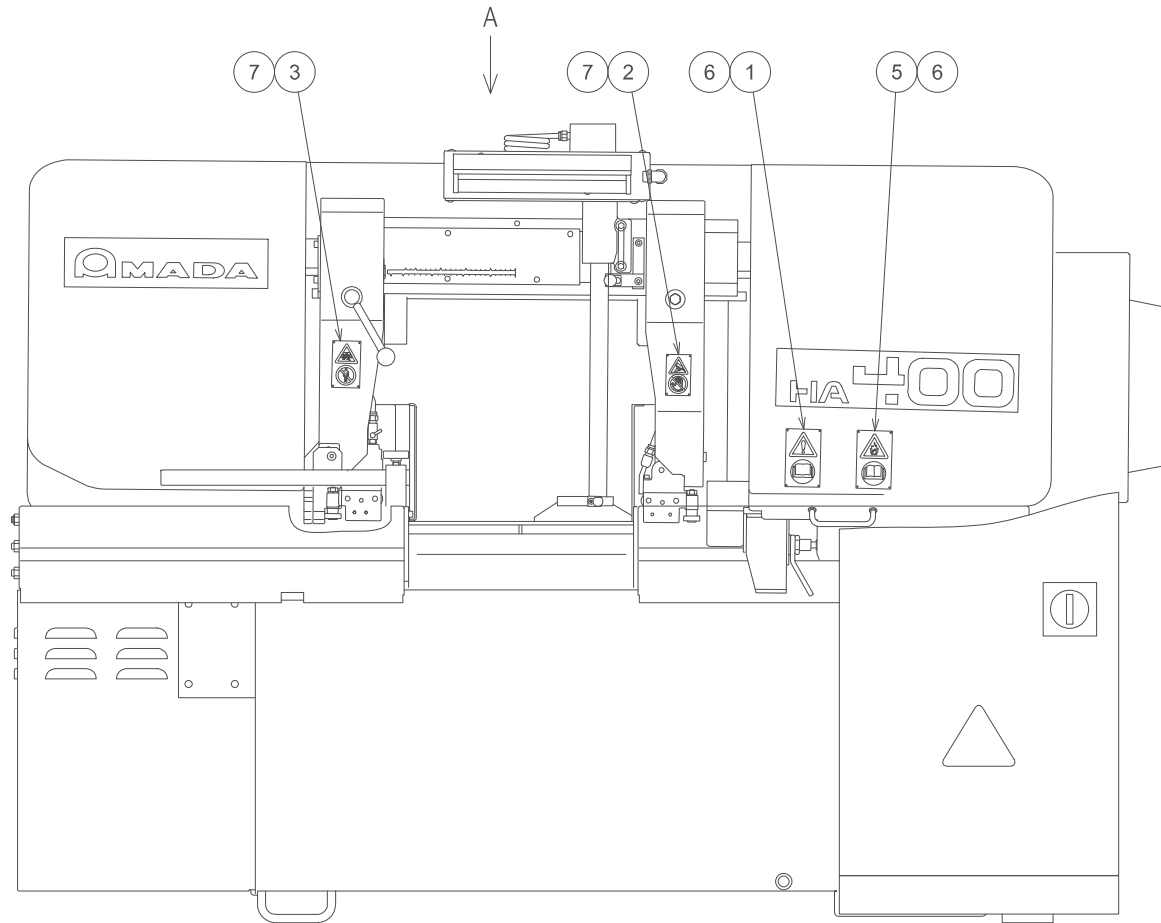

1278811--A

Unit No. 3
Name Plate(3)-2/2 <DOM>

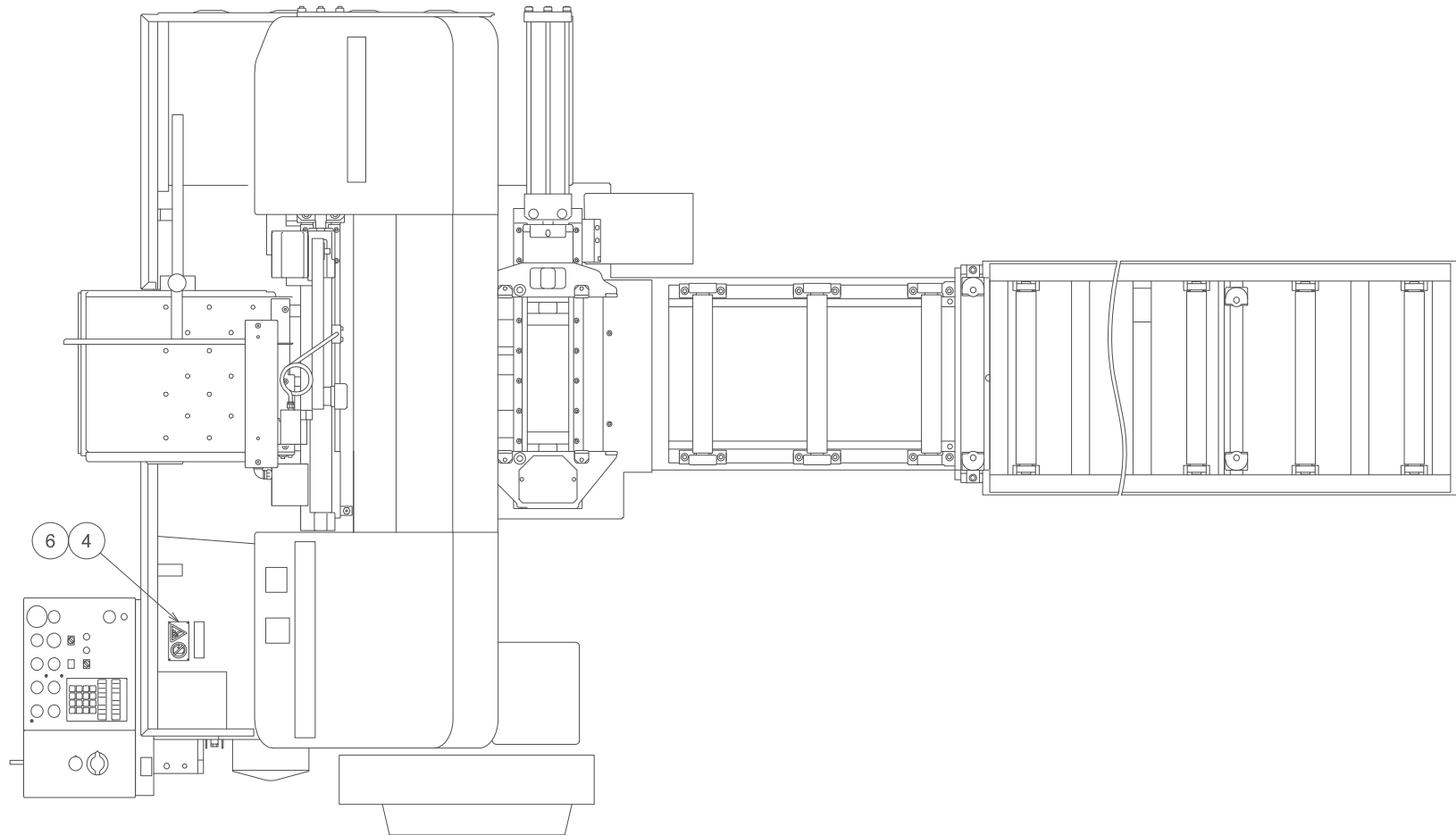

VIEW A

Unit No. 3
Name Plate(3)

Index	Code	Parts Name	Drawing No.	Type	Maker	Q'ty	Note
1	10301133	Warning Plate	RB0376631-			1	
2	10301557	Warning Plate	RB0376611-			1	
3	10301131	Warning Plate	RB0376621-			1	
4	10301134	Warning Plate	RB0376641-			1	
5	10301129	Warning Plate	RB0376601-			1	
6	10345260	Blind Rivet	P339208002	NSA3-2	LOBTEX	12	
7	10375027	Drive Screw	P339100002	NO.2X4.8	Tokyo Byora	8	

Unit No. 4
Name Plate(4) <HA400W>

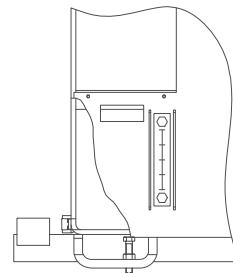
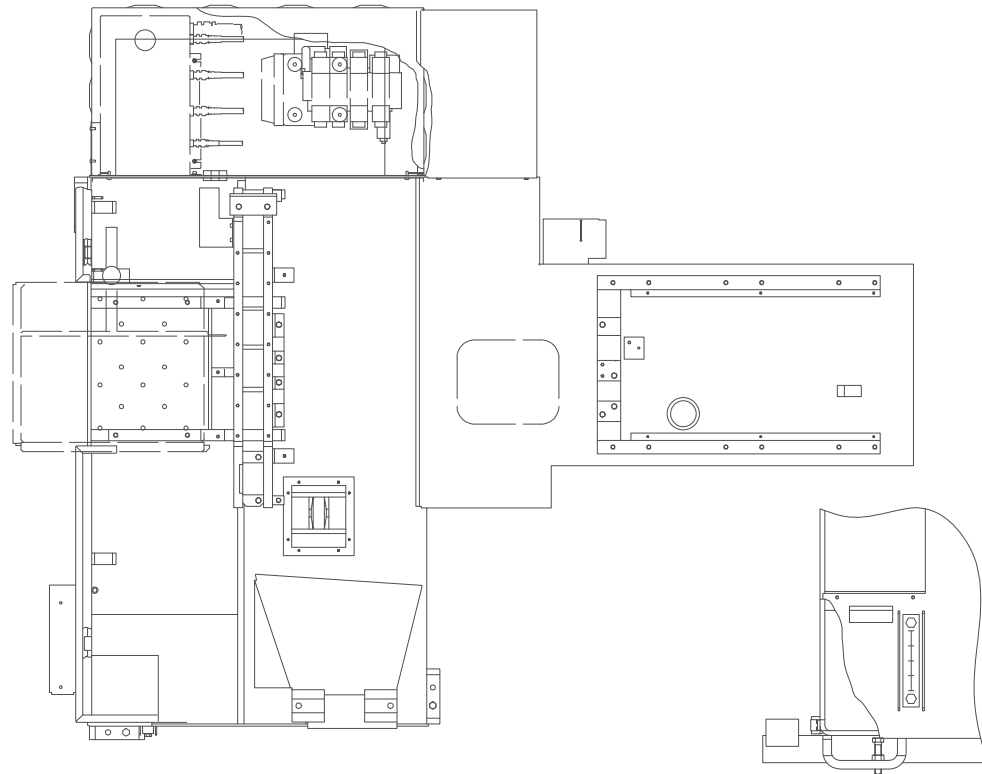
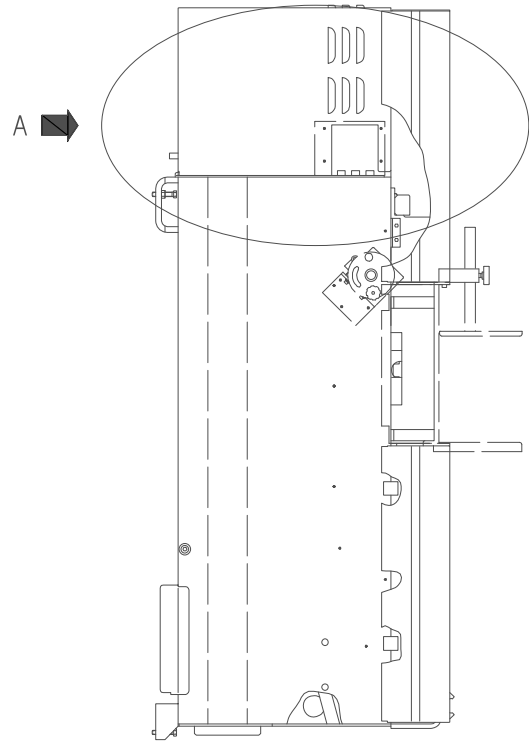

DETAIL B

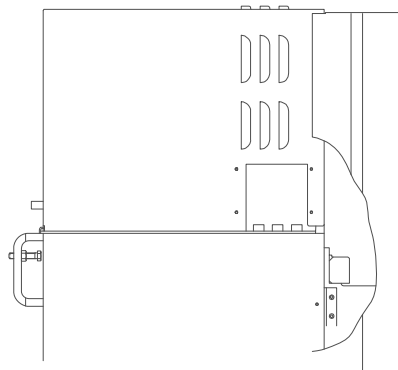

DETAIL A

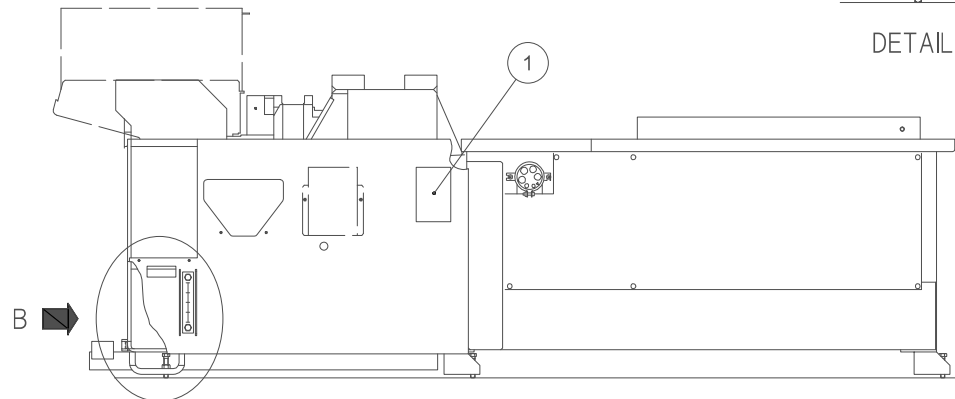

Unit No. 4
Name Plate(4)

Index	Code	Parts Name	Drawing No.	Type	Maker	Q'ty	Note
1	10301508	Serial Plate	RB02375--A			1	

Unit No. 5
Name Plate(5)-1/3 <US>

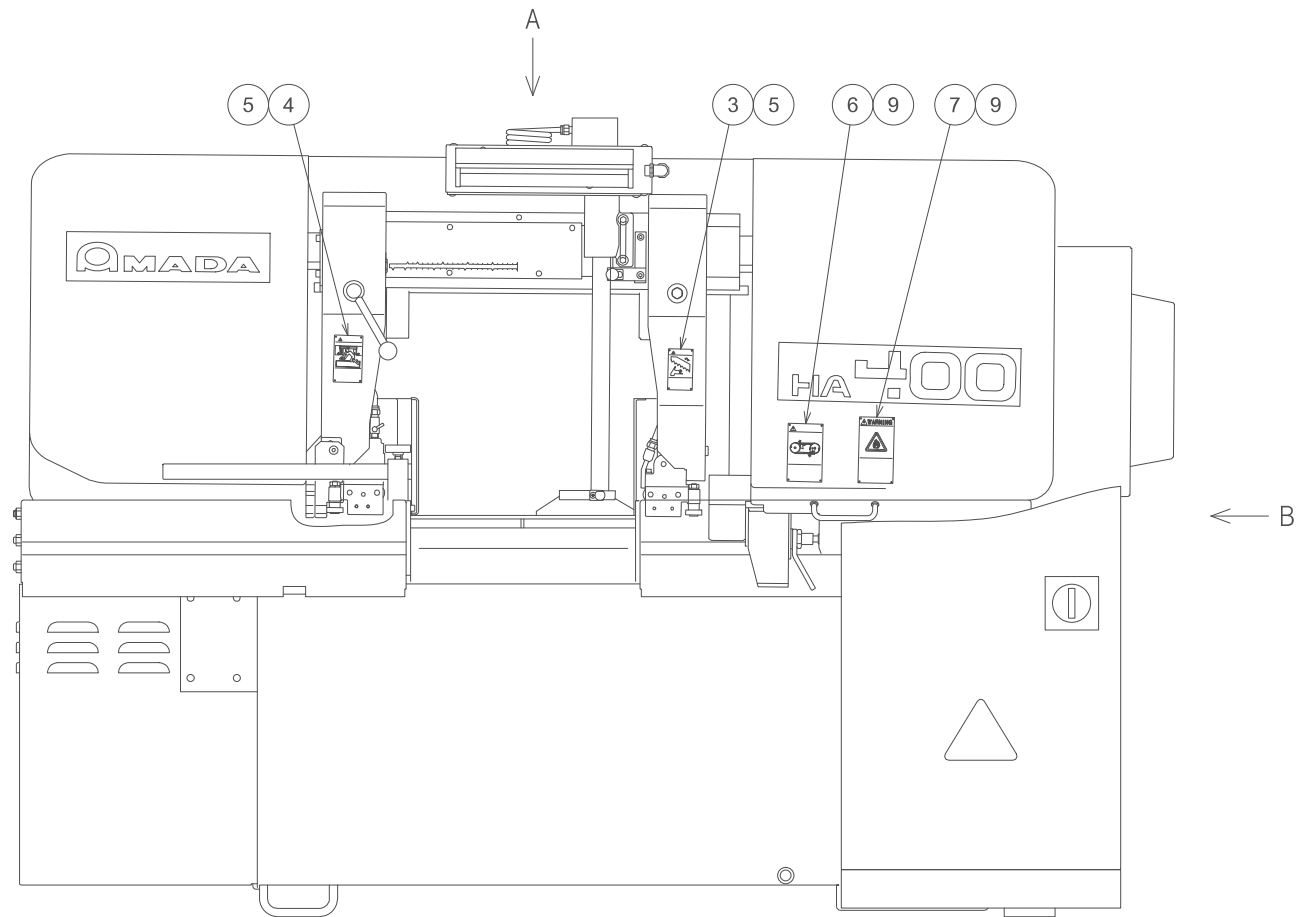

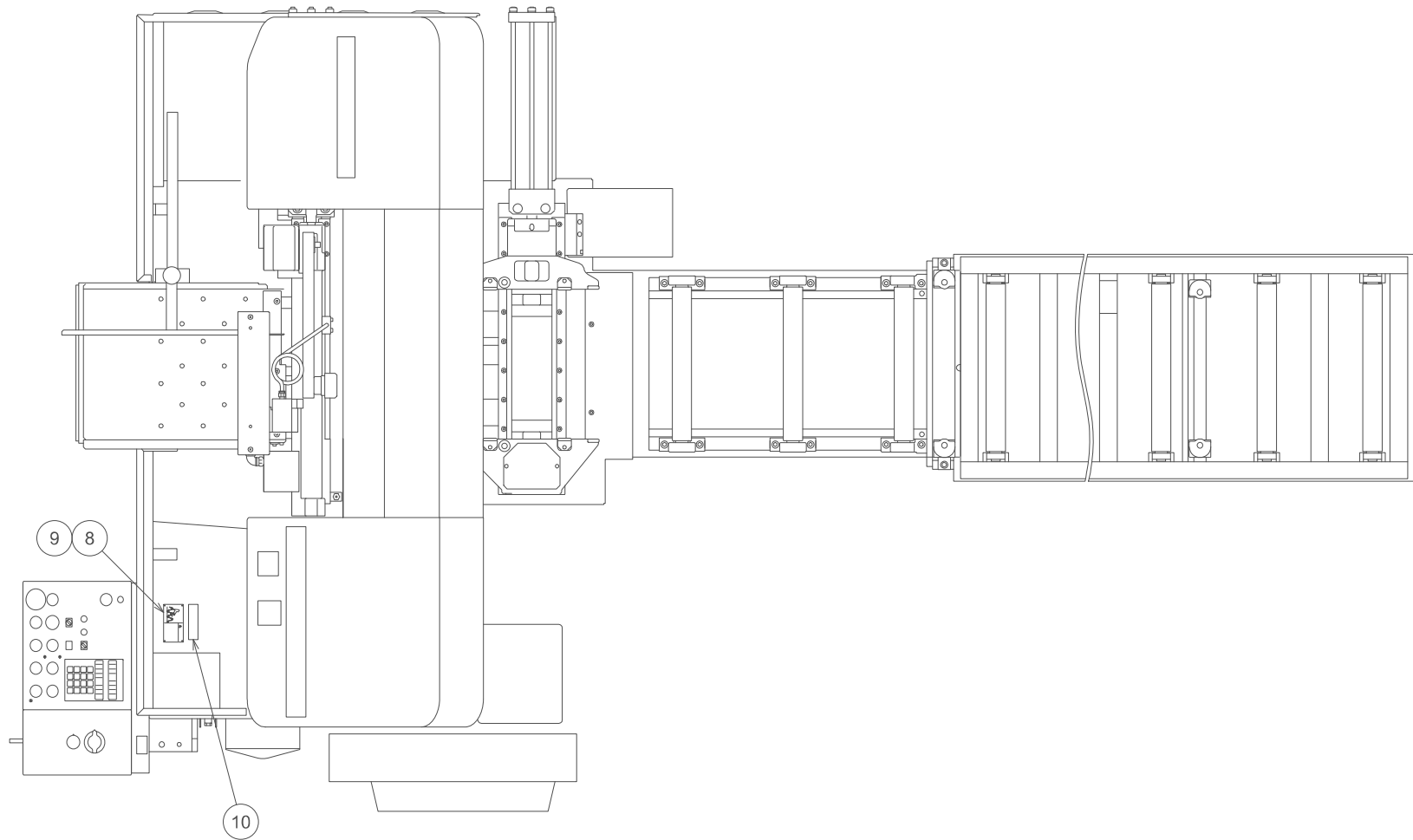

VIEW A

Unit No. 5
Name Plate(5)-3/3 <US>

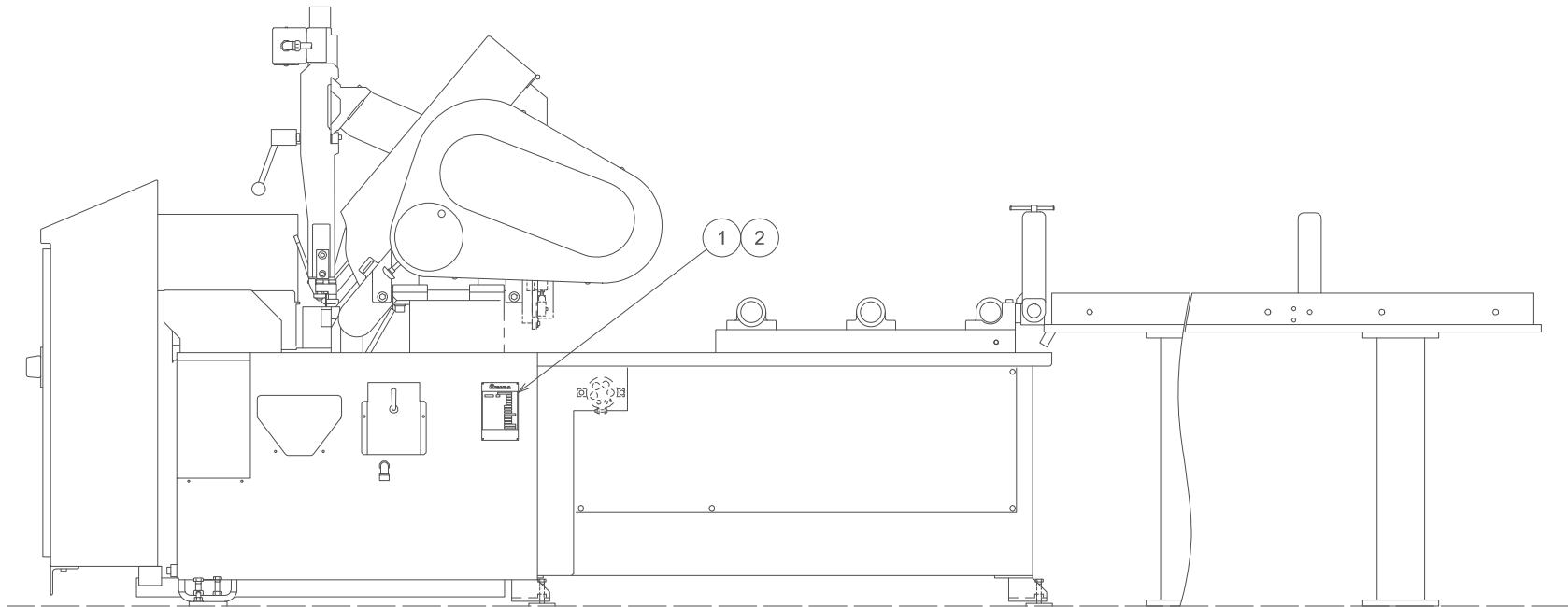

VIEW B

RB02471---

Unit No. 5
Name Plate(5)

Index	Code	Parts Name	Drawing No.	Type	Maker	Q'ty	Note
1	10301392	Serial Plate	RB01768---			1	for 34mm
1	10301509	Serial Plate	RB02376---			1	for 41mm
2	10375027	Drive Screw	P339100002	NO.2X4.8	Tokyo Byora	4	
3	10301558	Warning Plate	RB0376612-			1	
4	10301132	Warning Plate	RB0376622-			1	
5	10375027	Drive Screw	P339100002	NO.2X4.8	Tokyo Byora	8	
6	10301490	Warning Plate	RB02212---			1	
7	10301130	Warning Plate	RB0376602-			1	
8	10301135	Warning Plate	RB0376642-			1	
9	10345260	Blind Rivet	P339208002	NSA3-2	LOBTEX	12	
10	10300877	Caution Plate	RB00871---			1	

Unit No. 6
Name Plate(6)-1/3 <EU>

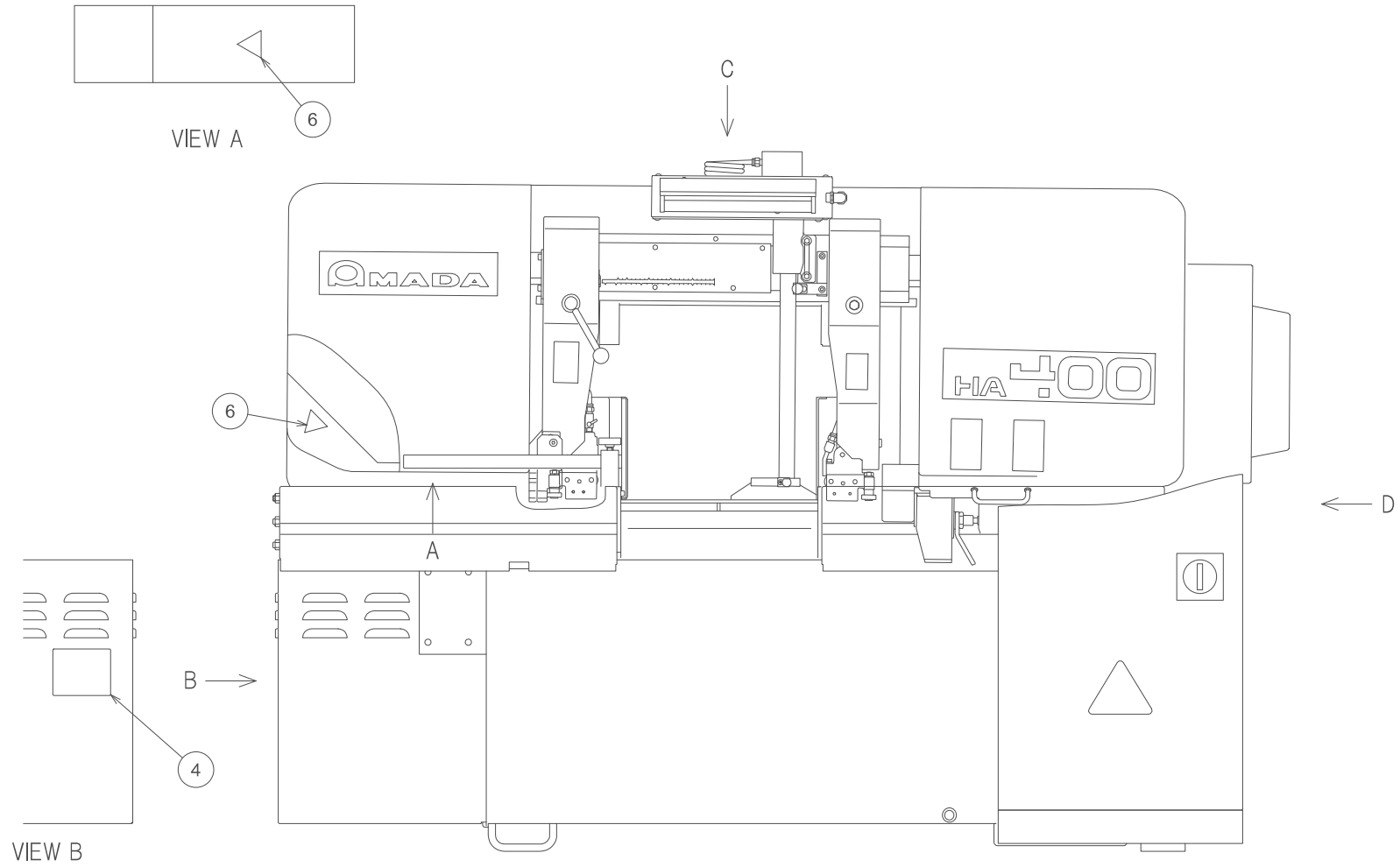

RB02472---

Unit No. 6
Name Plate(6)-2/3 <EU>

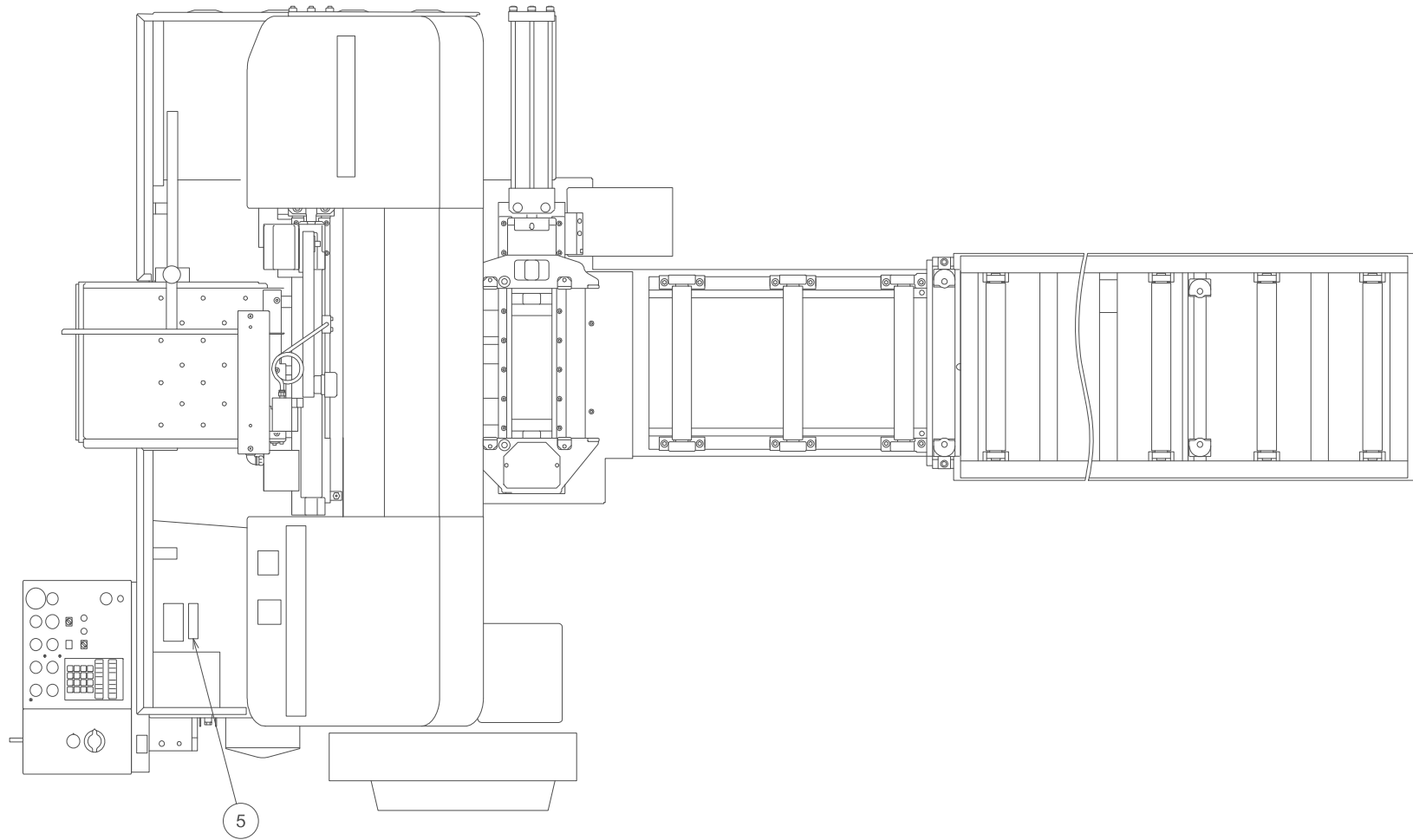

VIEW C

Unit No. 6
Name Plate(6)-3/3 <EU>

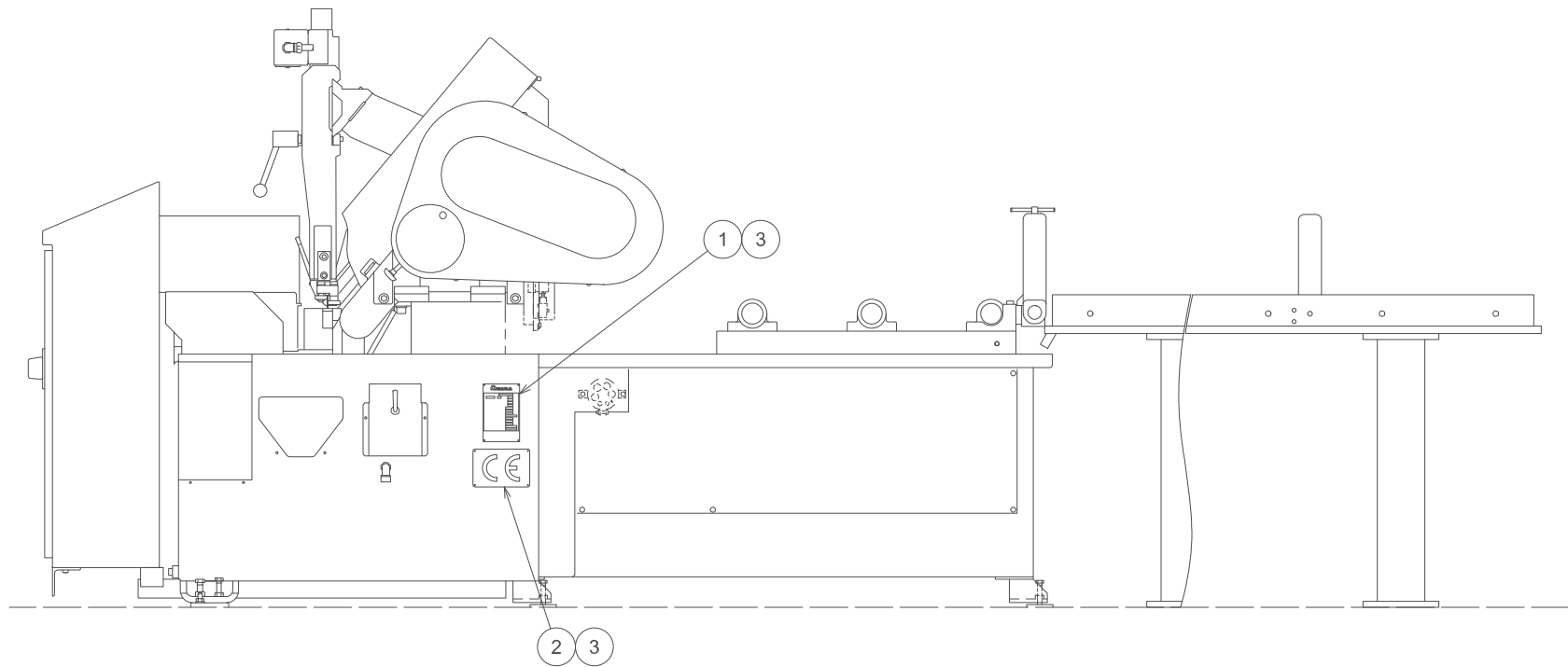

VIEW D

RB02472---

Unit No. 6
Name Plate(6)

Index	Code	Parts Name	Drawing No.	Type	Maker	Q'ty	Note
1	10301392	Serial Plate	RB01768---			1	for 34mm
1	10301509	Serial Plate	RB02376---			1	for 41mm
2	10376479	CE Mark Plate	1279130			1	
3	10375027	Drive Screw	P339100002	NO.2X4.8	Tokyo Byora	8	
4	10301166	Caution Plate	1230982			1	
5	10376769	Sticker	1106982			1	List Only
6	10301179	Seal	124469735	PRE-K005 78mmX78mm		2	

Unit No. 7
Name Plate(7)-1/3 <AS>

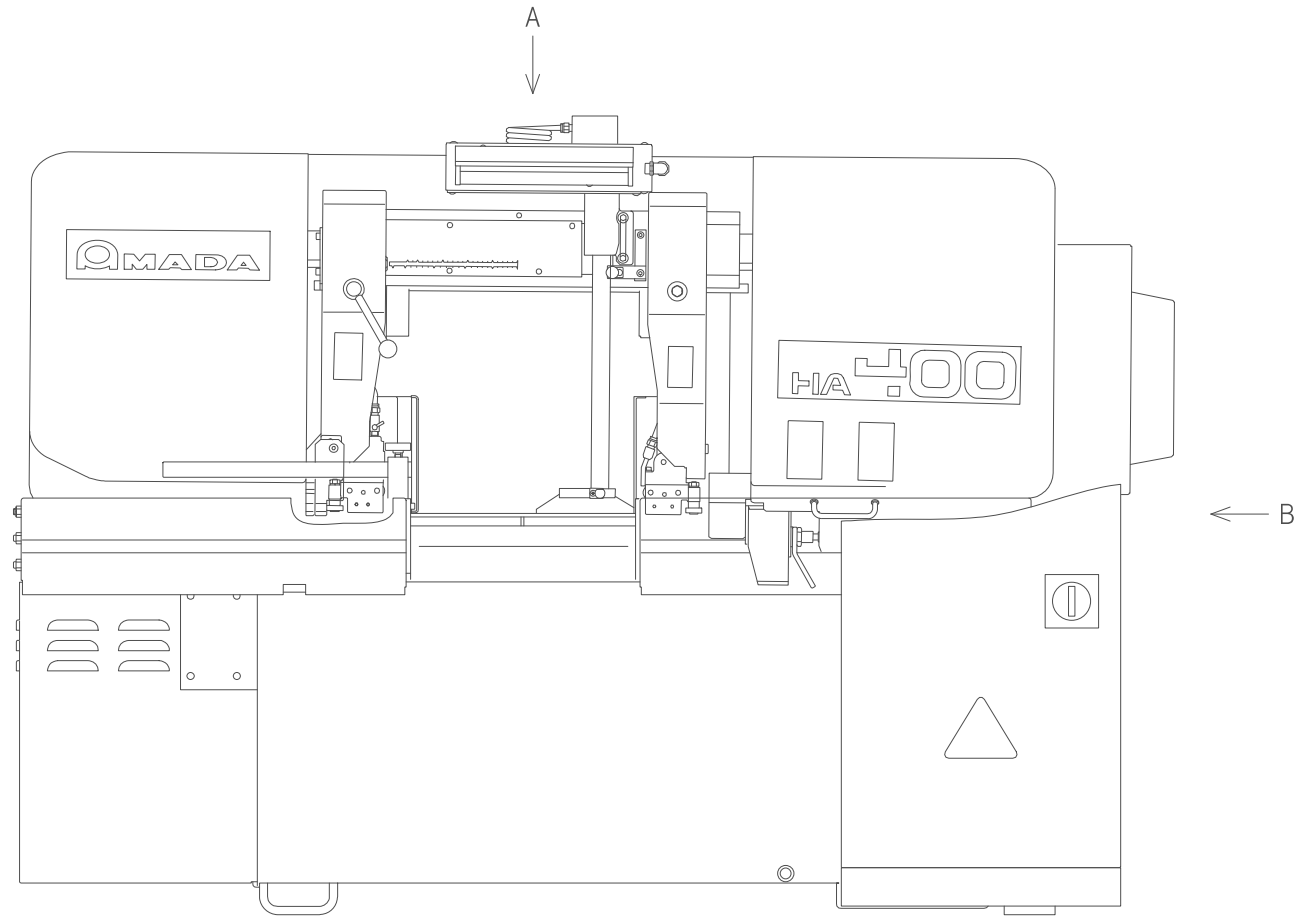

RB02473---

Unit No. 7
Name Plate(7)-2/3 <AS>

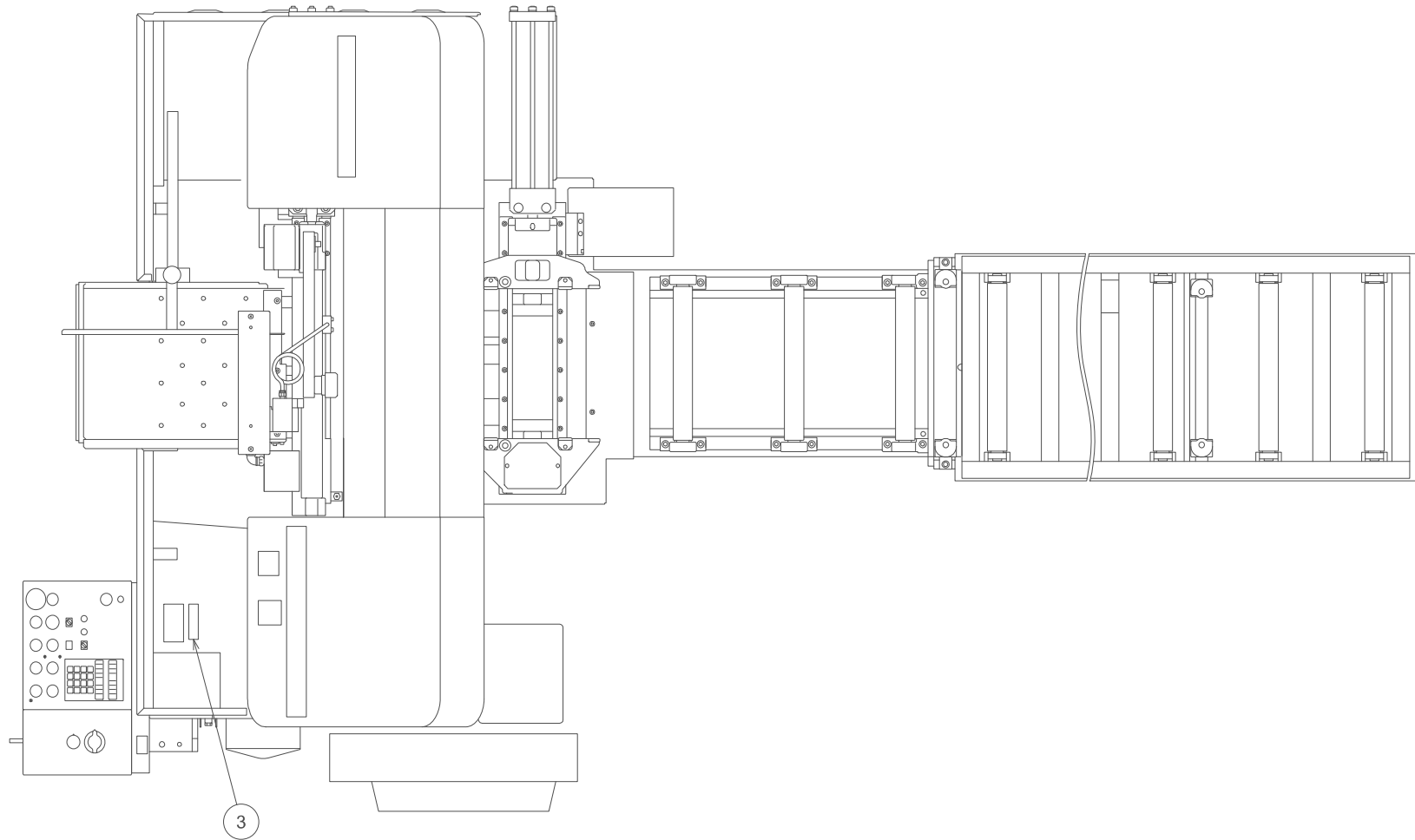

VIEW A

Unit No. 7
Name Plate(7)-3/3 <AS>

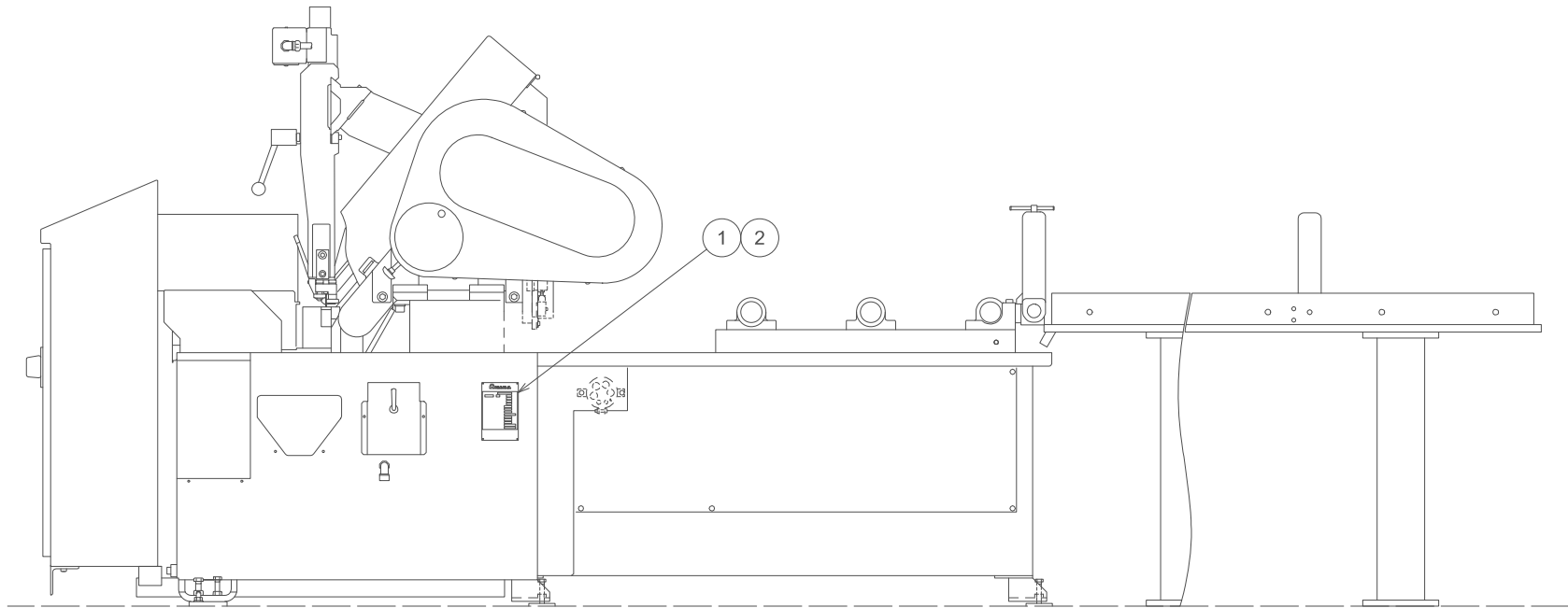

VIEW B

RB02473---

Unit No. 7
Name Plate(7)

Index	Code	Parts Name	Drawing No.	Type	Maker	Q'ty	Note
1	10301392	Serial Plate	RB01768---			1	for 34mm
1	10301509	Serial Plate	RB02376---			1	for 41mm
2	10375027	Drive Screw	P339100002	NO.2X4.8	Tokyo Byora	4	
3	10300877	Caution Plate	RB00871---			1	

Unit No. 8
Name Plate(8)-1/3 <CHI>

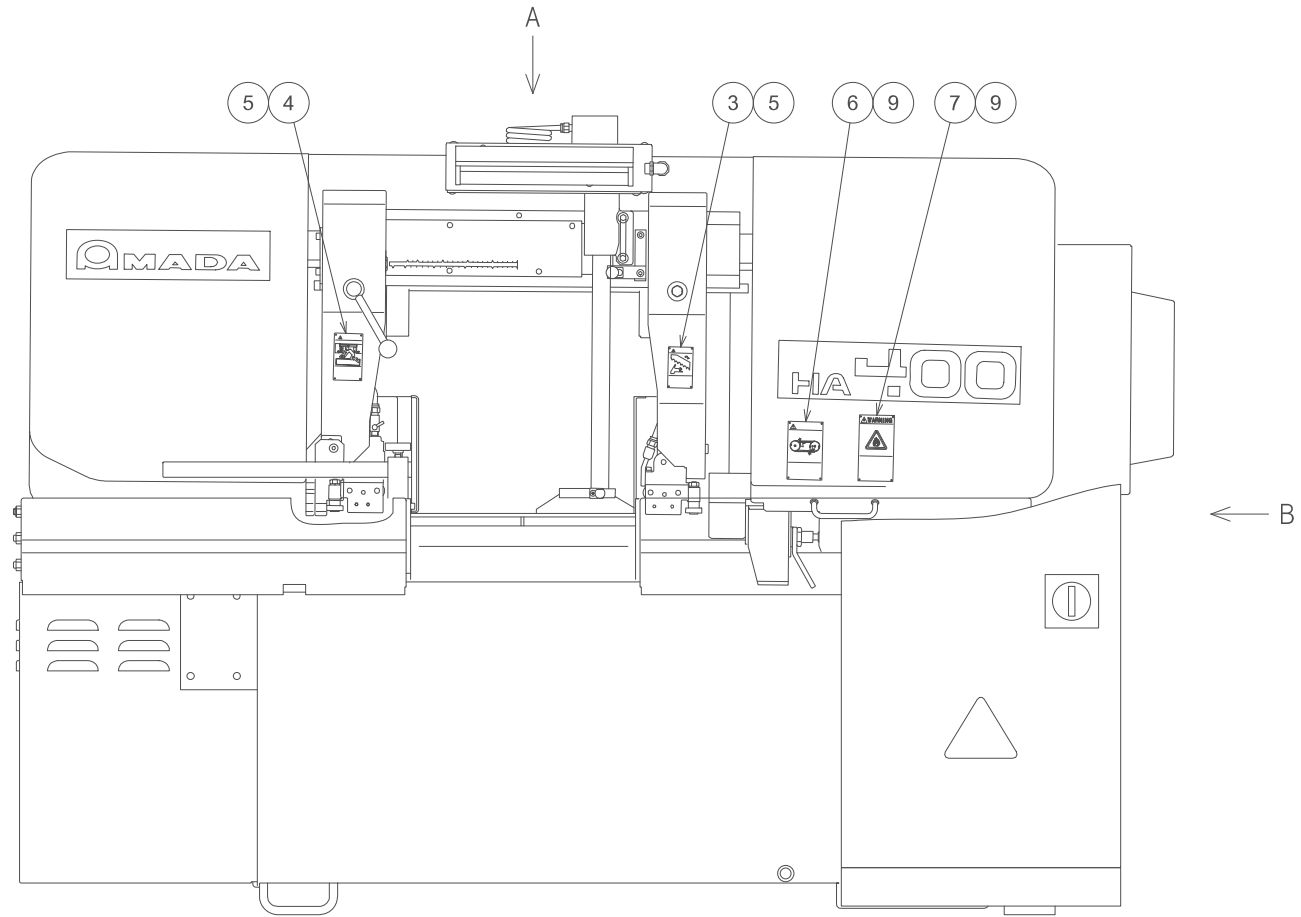

RB02474---

Unit No. 8
Name Plate(8)-2/3 <CHI>

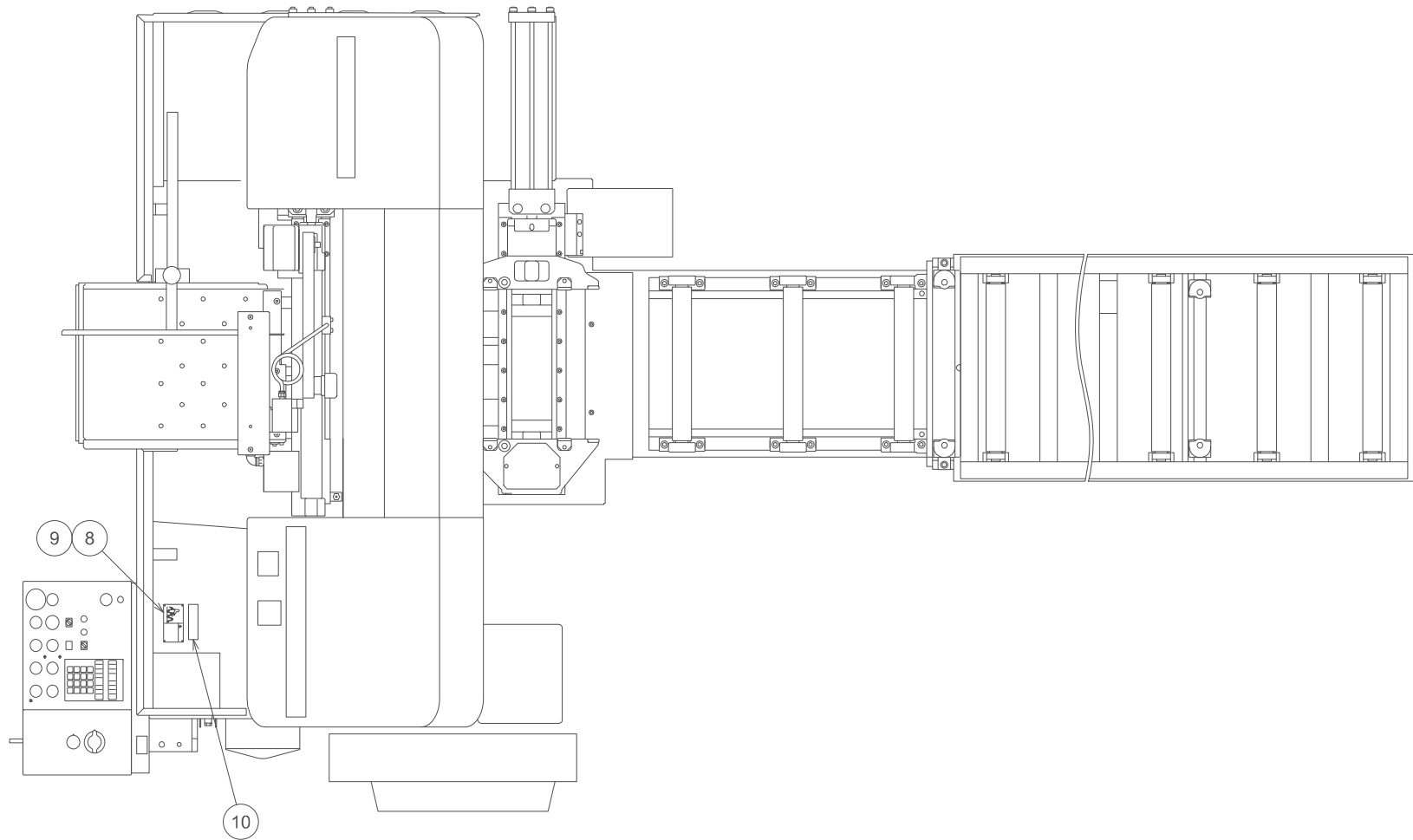

VIEW A

Unit No. 8
Name Plate(8)-3/3 <CHI>

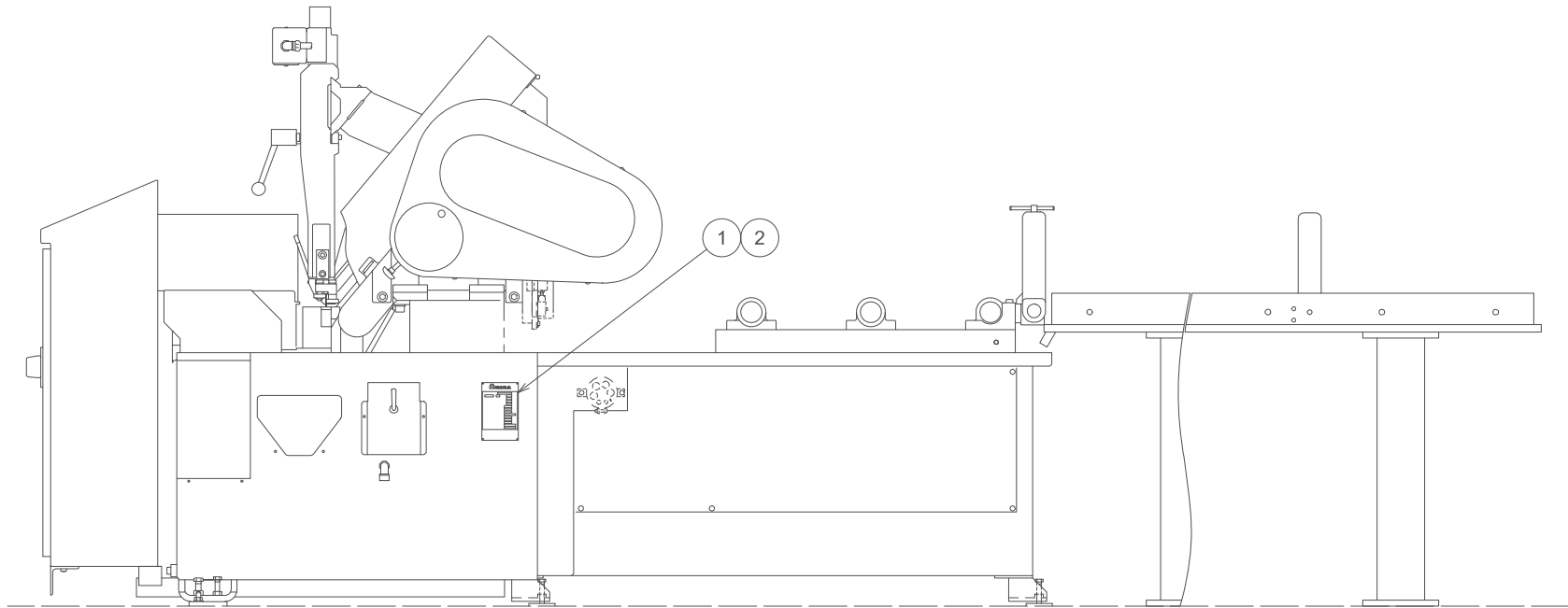

VIEW B

RB02474---

Unit No. 8
Name Plate(8)

Index	Code	Parts Name	Drawing No.	Type	Maker	Q'ty	Note
1	10301393	Serial Plate	RB01769--B			1	for 34mm
1	10301512	Serial Plate	RB02379--B			1	for 41mm
2	10375027	Drive Screw	P339100002	NO.2X4.8	Tokyo Byora	4	
3	10301147	Warning Plate	1205087 A			1	
4	10300086	Warning Plate	1109435			1	
5	10375027	Drive Screw	P339100002	NO.2X4.8	Tokyo Byora	8	
6	10301491	Warning Plate	RB02213---			1	
7	10300088	Warning Plate	1109441			1	
8	10300089	Warning Plate	1109442			1	
9	10345260	Blind Rivet	P339208002	NSA3-2	LOBTEX	12	
10	10300090	Sticker	1109443			1	

Unit No. 9
Machine Body(1)-1/2 <Oil Pan>

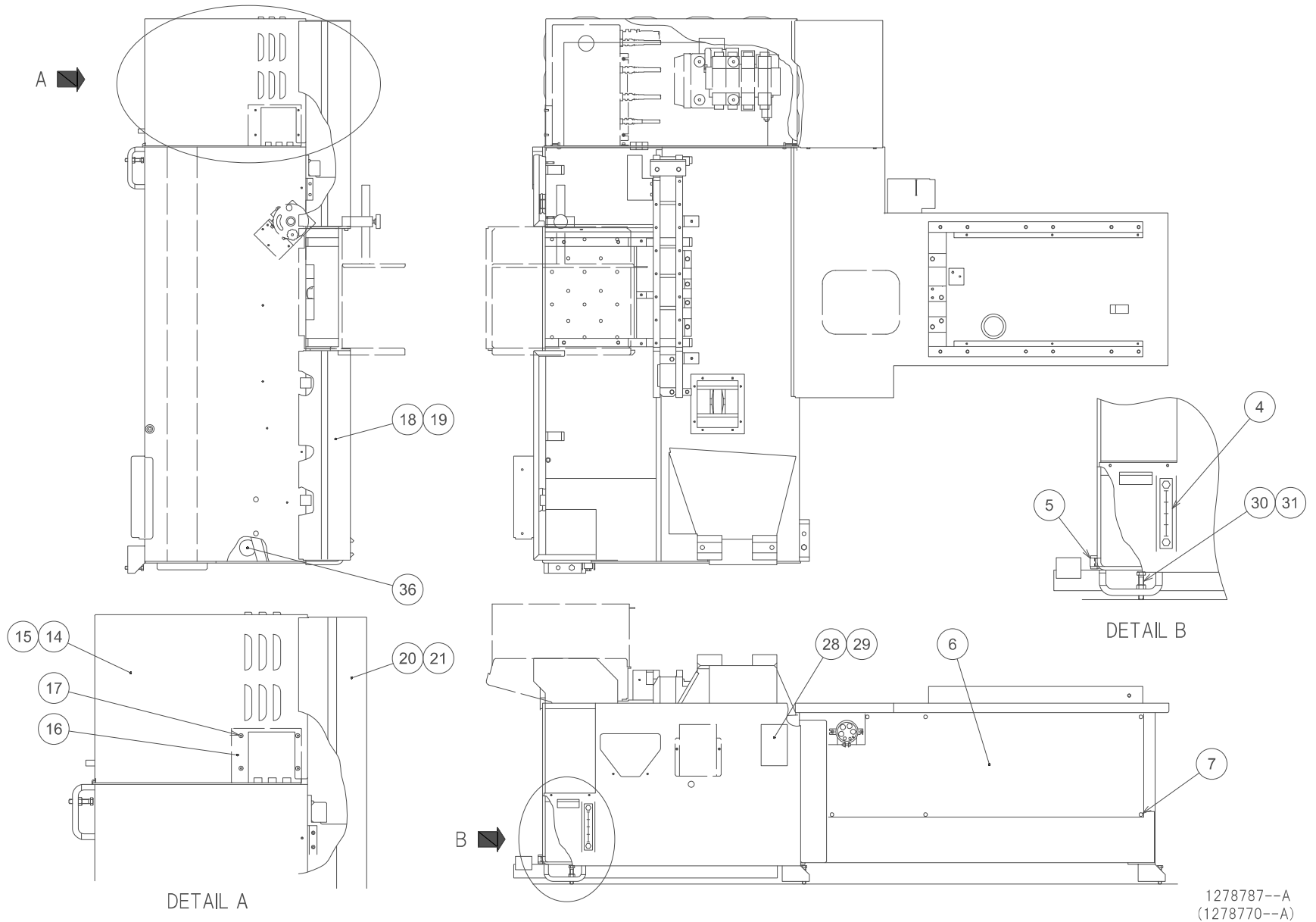

1278787--A
(1278770--A)

Unit No. 9
Machine Body(1)-2/2 <Oil Pan>

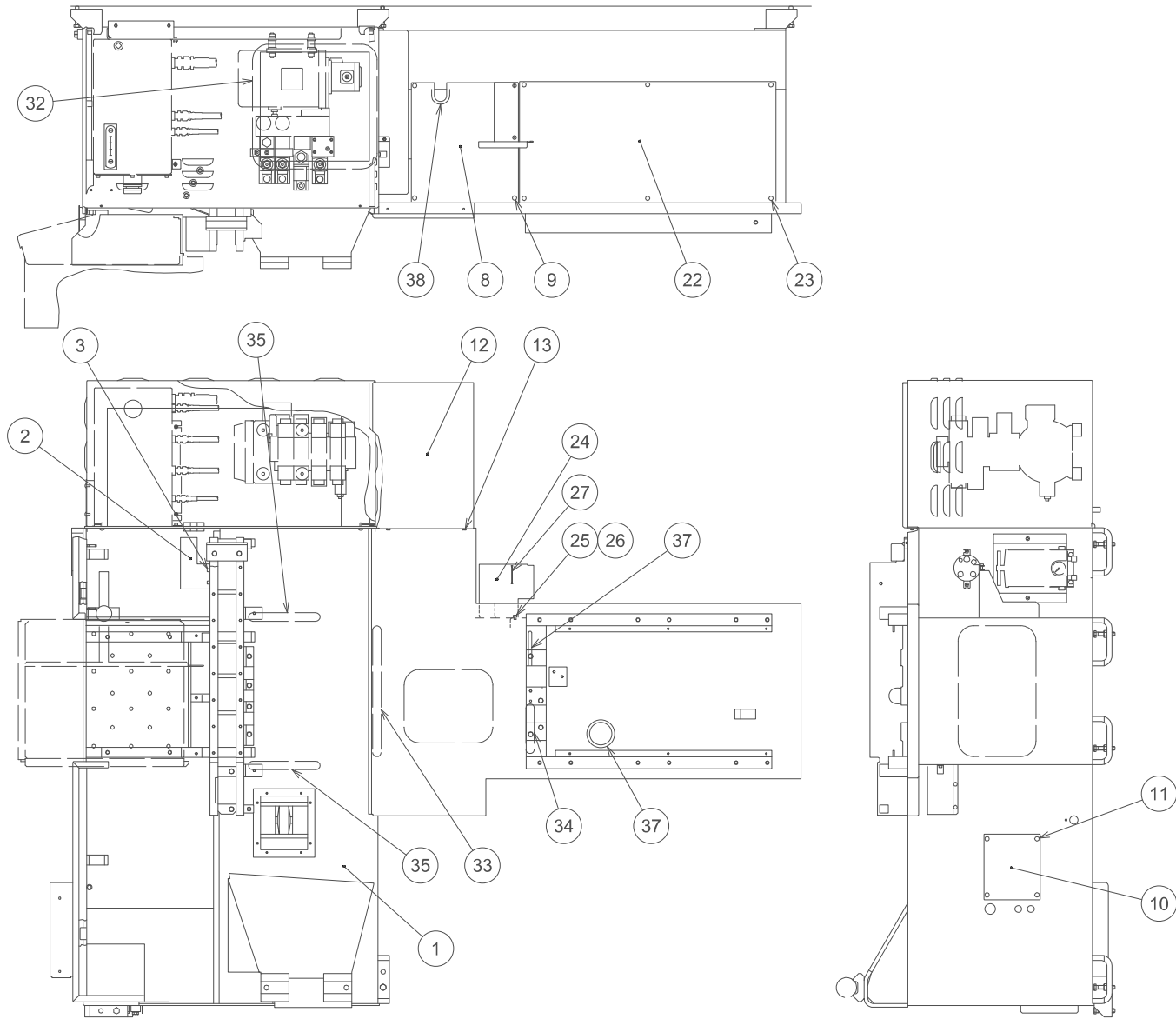

1278787--A
(1278770--A)

Unit No. 9
Machine Body(1)

Index	Code	Parts Name	Drawing No.	Type	Maker	Q'ty	Note
1	10301385	Oil Pan	RB01704--C			1	
2	10378016	Hose Cover	1238059			1	
3	10323201	Hex Socket Cap Screw	P330220004	M6X12	JIS	2	
4	10383587	Level Gauge	P600108032	KLA-140A(Float Red)	KYOWA	1	
5	10322231	Plug for Piping	P580180004	1/2		1	
6	10583571	Rear Side Cover RH	1230567 A			1	
7	10340019	Truss Head Screw	P334130012	M6X12	JIS	7	
8	10583572	Rear Side Cover LH	1230566 B			1	
9	10340019	Truss Head Screw	P334130012	M6X12	JIS	3	
10	10321749	Rear Cover	1230032 A			1	
11	10340019	Truss Head Screw	P334130012	M6X12	JIS	4	
12	10583573	Safety Cover	1230071			1	
13	10325407	Bolt	P330020003	M6X12	JIS	2	
14	10419301	Auxiliary Oil Pan Cover	1238524 A			1	
15	10322133	Truss Head Screw	P334130014	M6X20	JIS	2	
16	10321958	Cover	1230040			1	
17	10340019	Truss Head Screw	P334130012	M6X12	JIS	4	
18	10301386	Splash Guard R	RB01712--B			1	
19	10340019	Truss Head Screw	P334130012	M6X12	JIS	1	

Unit No. 9
Machine Body(1)

Index	Code	Parts Name	Drawing No.	Type	Maker	Q'ty	Note
20	10301387	Splash Guard L	RB01713--A			1	
21	10340019	Truss Head Screw	P334130012	M6X12	JIS	1	
22	10583574	Cover	1230584 A			1	
23	10340019	Truss Head Screw	P334130012	M6X12	JIS	6	
24	10583575	Hose Support	1230644 B			1	
25	10589206	Hex Socket Cap Screw	P330220003	M6X10		2	
26	10321922	Washer	P336000005	6(Normal)	JIS	2	
27	10375463	Cable Band	P381058035	SKB-2M	KITAGAWA	1	
28	10301391	Serial Plate	RB01766--A			1	
29	10375027	Drive Screw	P339100002	NO.2X4.8	Tokyo Byora	4	
30	10343764	Bolt	P330050011	M12X60(All-thread)	MOURI	6	
31	10589227	Nut	P332000007	M12	JIS	6	
32	10301317	Flexible Conduit	P869028113	CTUB22-1.55M	MISUMI	1	
33	10301318	Flexible Conduit	P869028114	CTUB22-1.25M	MISUMI	1	
34	10301319	Flexible Conduit	P869028115	CTUB22-0.75M	MISUMI	1	
35	10583173	Flexible Conduit	P869028085	CTUB22-0.6M	MISUMI	2	
36	10301320	Flexible Conduit	P869028120	CTUB13-0.23M	MISUMI	1	
37	10301315	Flexible Conduit	P869028105	CTUB7-0.3M	MISUMI	2	
38	10301316	Flexible Conduit	P869028111	CTUB7-0.2M	MISUMI	1	

Unit No. 10
Machine Body(2) <EU Specification Machine>

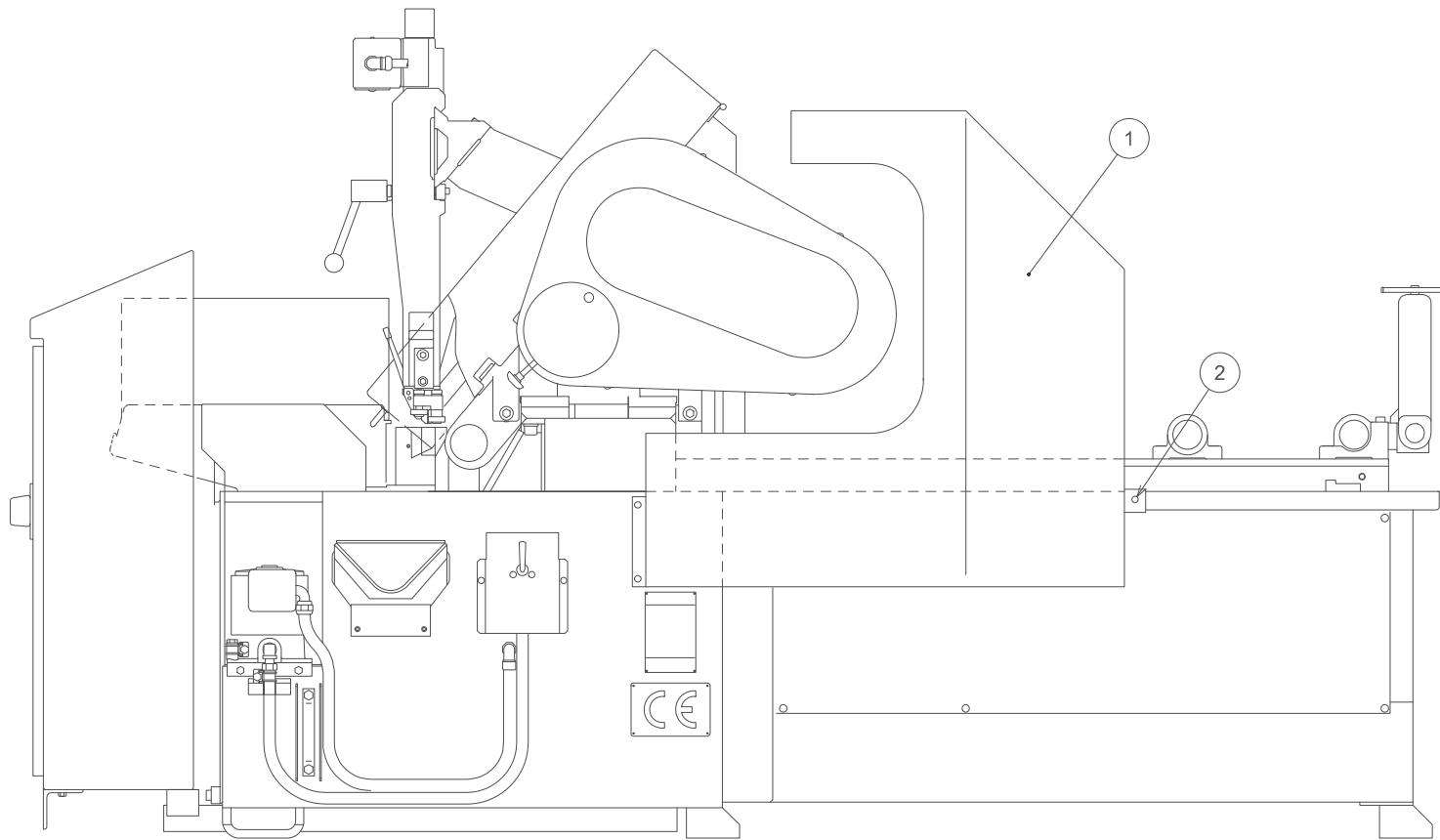

1230340

Unit No. 10
Machine Body(2)

Index	Code	Parts Name	Drawing No.	Type	Maker	Q'ty	Note
1	10301161	Safety Cover	1230974			1	
2	10385708	Truss Head Screw	P334130011	M6X10	JIS	3	

Unit No. 11
Machine Body(3)-1/2 <Hinge>

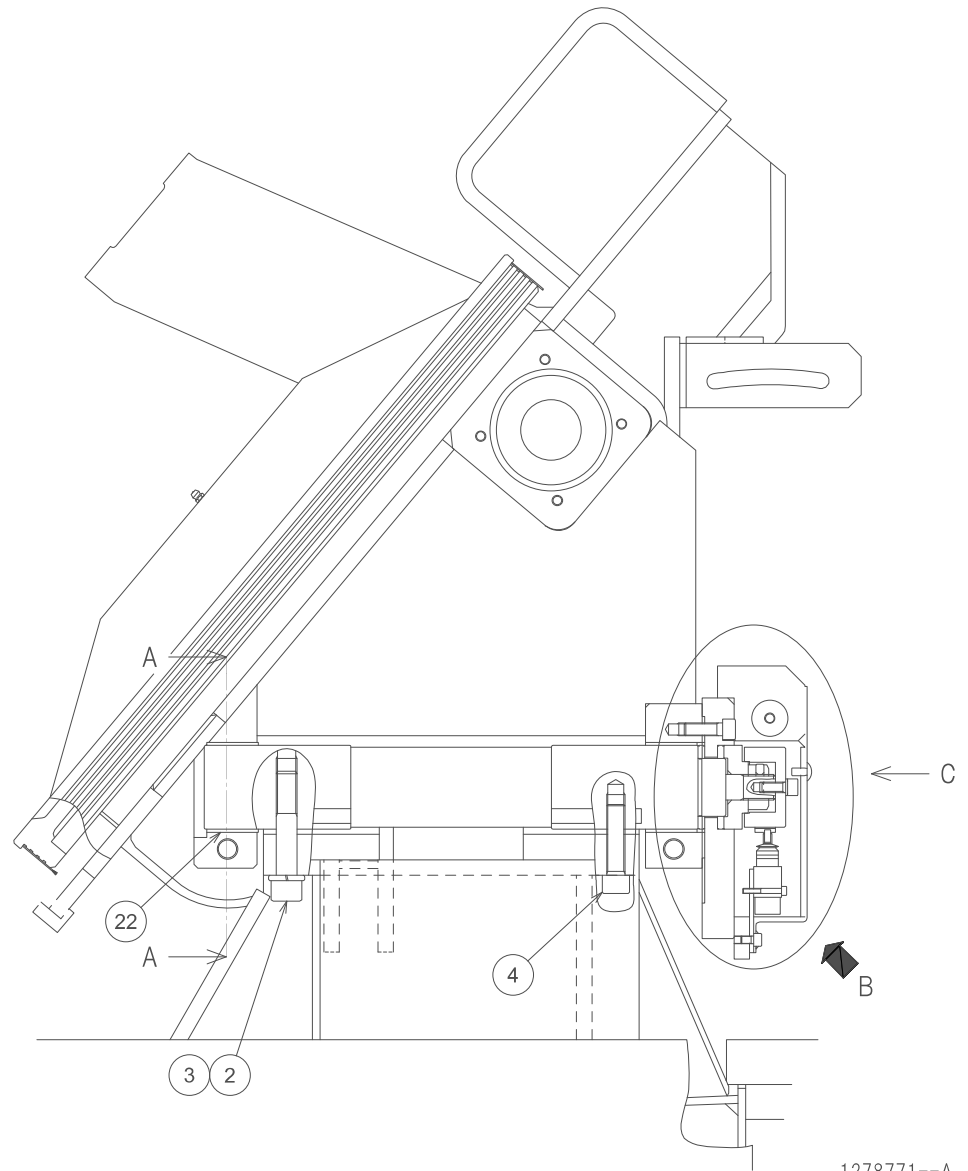
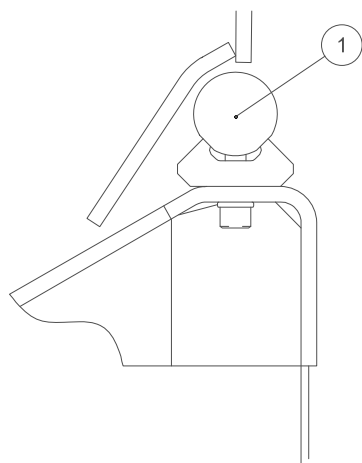
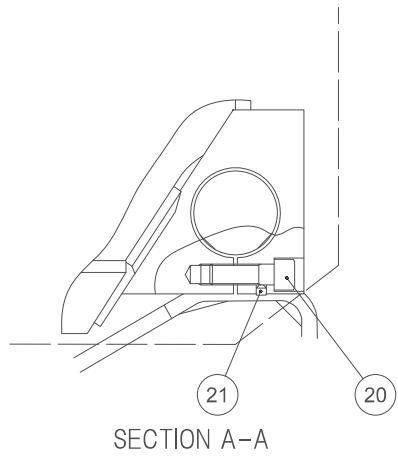

1278771--A

Unit No. 11
Machine Body(3)-2/2 <Hinge>

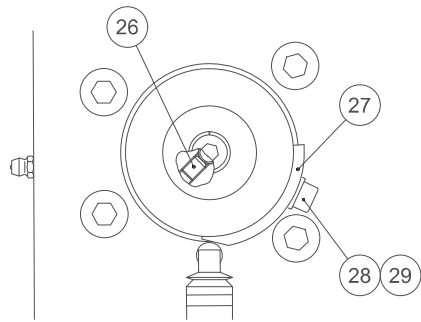

DETAIL D

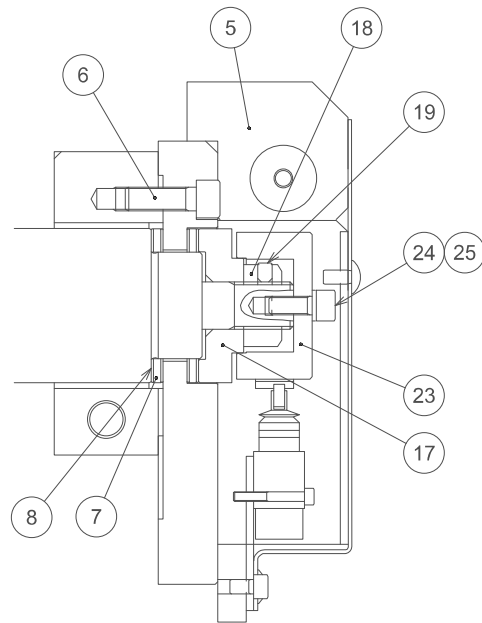

DETAIL B

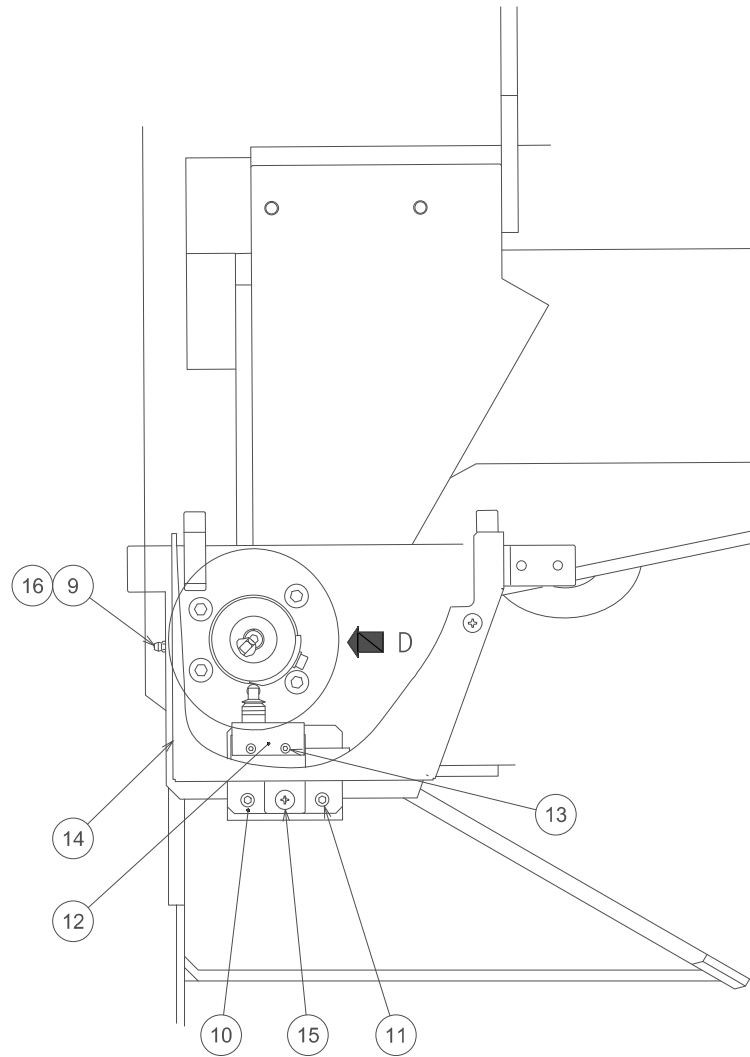

VIEW C

1278771--A

Unit No. 11
Machine Body(3)

Index	Code	Parts Name	Drawing No.	Type	Maker	Q'ty	Note
1	10419307	Hinge Pin	1238030 B			1	
2	10583225	Reamer Bolt L	1230017 C			1	
3	10583578	Conical Spring Washer	124469718			1	
4	10322210	Hex Socket Cap Screw	P330260009	M14X55	JIS	1	
5	10301388	Bearing Support	RB01723--A			1	
6	10322207	Hex Socket Cap Screw	P330240008	M10X30		4	
7	10322146	Roller Bearing	P402107001	FNTA-4565	NSK	2	
8	10322147	Bearing Ring	P406127001	FTRA-4565	NSK	4	
9	10419913	Grease Nipple	P560600002	A-MT6X1	JIS	1	
10	10583580	LS Bracket	1230602 A			1	
11	10589206	Hex Socket Cap Screw	P330220003	M6X10		2	
12	10348515	Limit Switch	P828012017	ZC-N2255	OMRON	1	
13	10359526	Hex Socket Cap Screw	P330200023	M4X30		2	
14	10301389	Cover	RB01725--A			1	
15	10340019	Truss Head Screw	P334130012	M6X12	JIS	3	
16	10323010	Name Plate	0852250			1	
17	10378035	Bearing Cap	1238032			1	
18	10321966	Nut	0603150	M20 (Type-1) Add Works		1	
19	10322120	Socket Set Screw	P330590018	M6X8(Dimple Type)	JIS	1	

Unit No. 11
Machine Body(3)

Index	Code	Parts Name	Drawing No.	Type	Maker	Q'ty	Note
20	10322205	Hex Socket Cap Screw	P330260034	M16X50		2	
21	10322125	Socket Set Screw	P330590023	M8X8(Dimple Type)	JIS	2	
22	10583582	Plain Bearing	P407003183	DUB6540	DAIDO METAL	2	
23	10583583	Dog Shaft	1230604 C			1	
24	10322202	Hex Socket Cap Screw	P330230006	M8X20		1	
25	10589279	Conical Spring Washer	P336165002	CDW-8H	HHK	1	
26	10329309	Socket Set Screw	P330550025	M6X8(Flat Type)	JIS	1	
27	10378036	Dog	1238037			1	
28	10589206	Hex Socket Cap Screw	P330220003	M6X10		1	
29	10301283	Conical Spring Washer	P336040002	1H-6	JIS	1	

Unit No. 12
Machine Body(4)-1/2 <Front View>

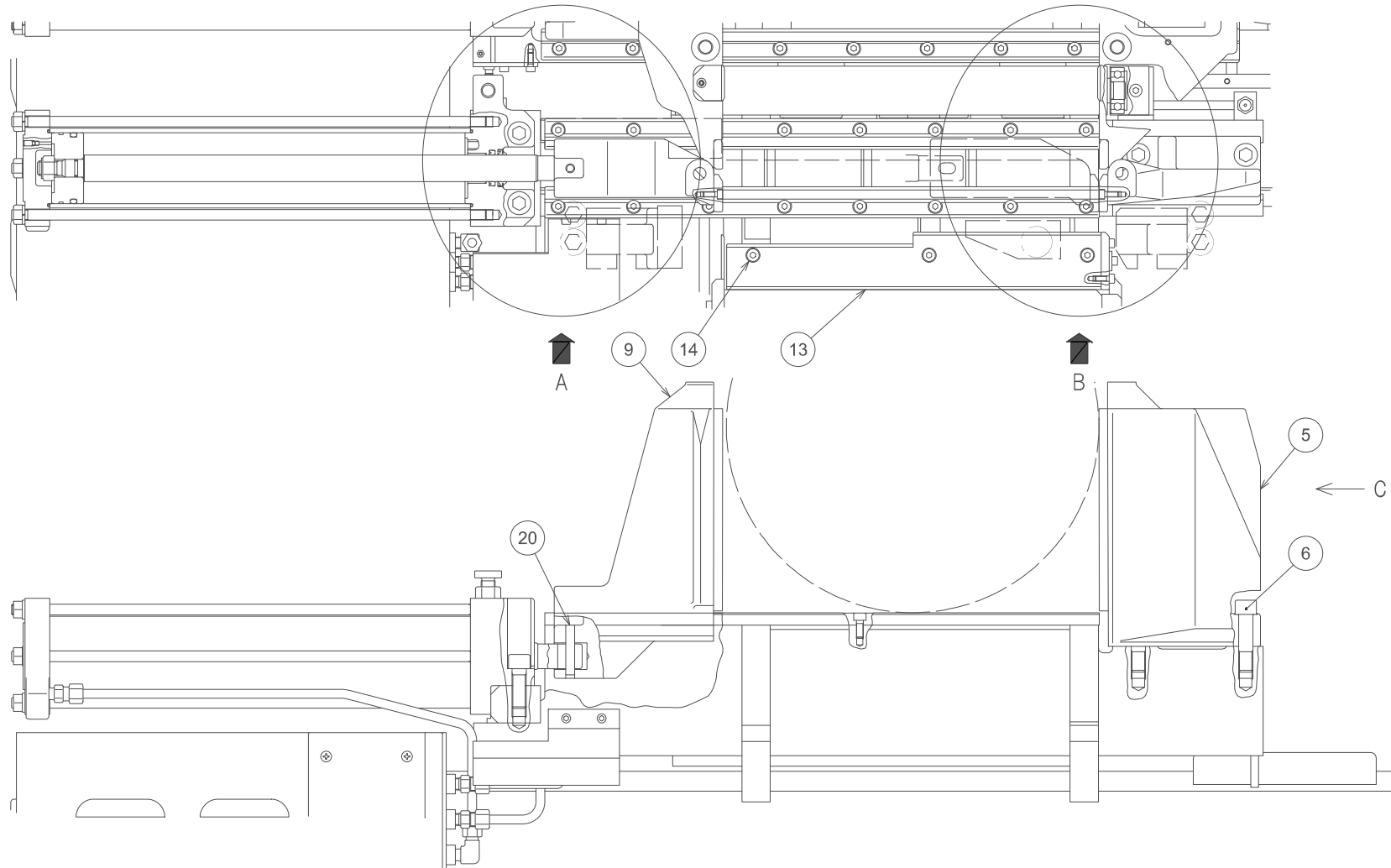

1278772--A

Unit No. 12
Machine Body(4)-2/2 <Front Vise>

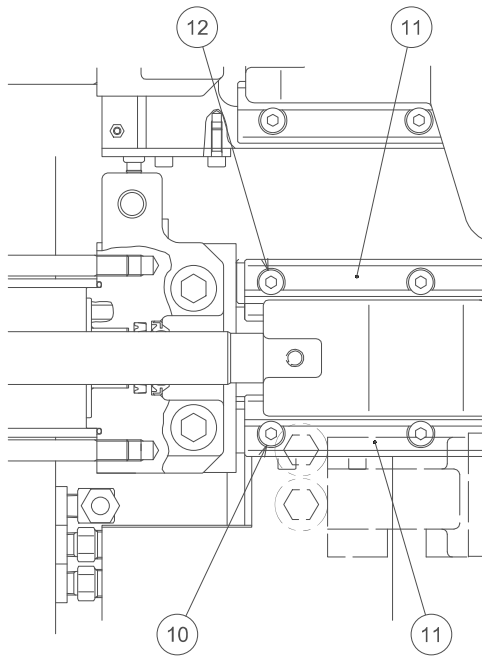

DETAIL A

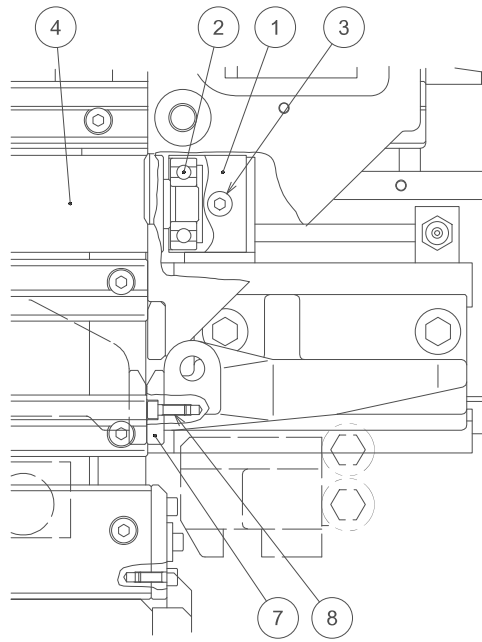

DETAIL B

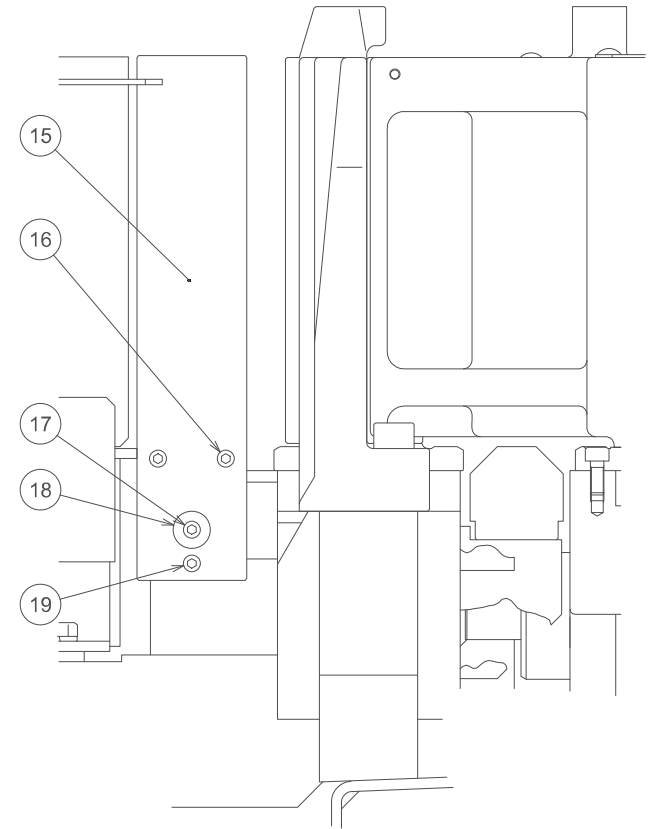

VIEW C

1278772--A

Unit No. 12
Machine Body(4)

Index	Code	Parts Name	Drawing No.	Type	Maker	Q'ty	Note
1	10376204	Roller Bracket	1233020 B			2	
2	10555909	Deep Groove Ball Bearing	P400017017	6304DDU	NSK	2	
3	10369809	Hex Socket Cap Screw	P330230014	M8X60		2	
4	10378048	Roller	1238488 A			1	
5	10419311	Stationary Vise Jaw	1238008 A			1	
6	10583584	Reamer Bolt	1108043 A			2	
7	10378046	Vise Plate	1238097 A			2	
8	10312831	Hex Socket Cap Screw	P330220006	M6X15		8	
9	10419312	Movable Vise Jaw	1238009 B			1	
10	10322202	Hex Socket Cap Screw	P330230006	M8X20		8	
11	10386018	Slide Plate	1238479 C			2	
12	10322202	Hex Socket Cap Screw	P330230006	M8X20		8	
13	10378031	Work Receiver	1238028			1	
14	10322202	Hex Socket Cap Screw	P330230006	M8X20		3	
15	10378032	Work Stopper Plate	1238029 A			1	
16	10312831	Hex Socket Cap Screw	P330220006	M6X15		2	
17	10324622	Hex Socket Cap Screw	P330220011	M6X25		1	
18	10321921	Washer	1230039			1	
19	10322126	Socket Set Screw	P330550049	M10X12(Flat Type)	JIS	1	

Unit No. 12

Machine Body(4)

Index	Code	Parts Name	Drawing No.	Type	Maker	Q'ty	Note
20	10322112	Spring Pin	P337030096	10X60AW	OHKITA	1	

Unit No. 13
Machine Body(5) <Vise Cylinder>

1 Index 2-21

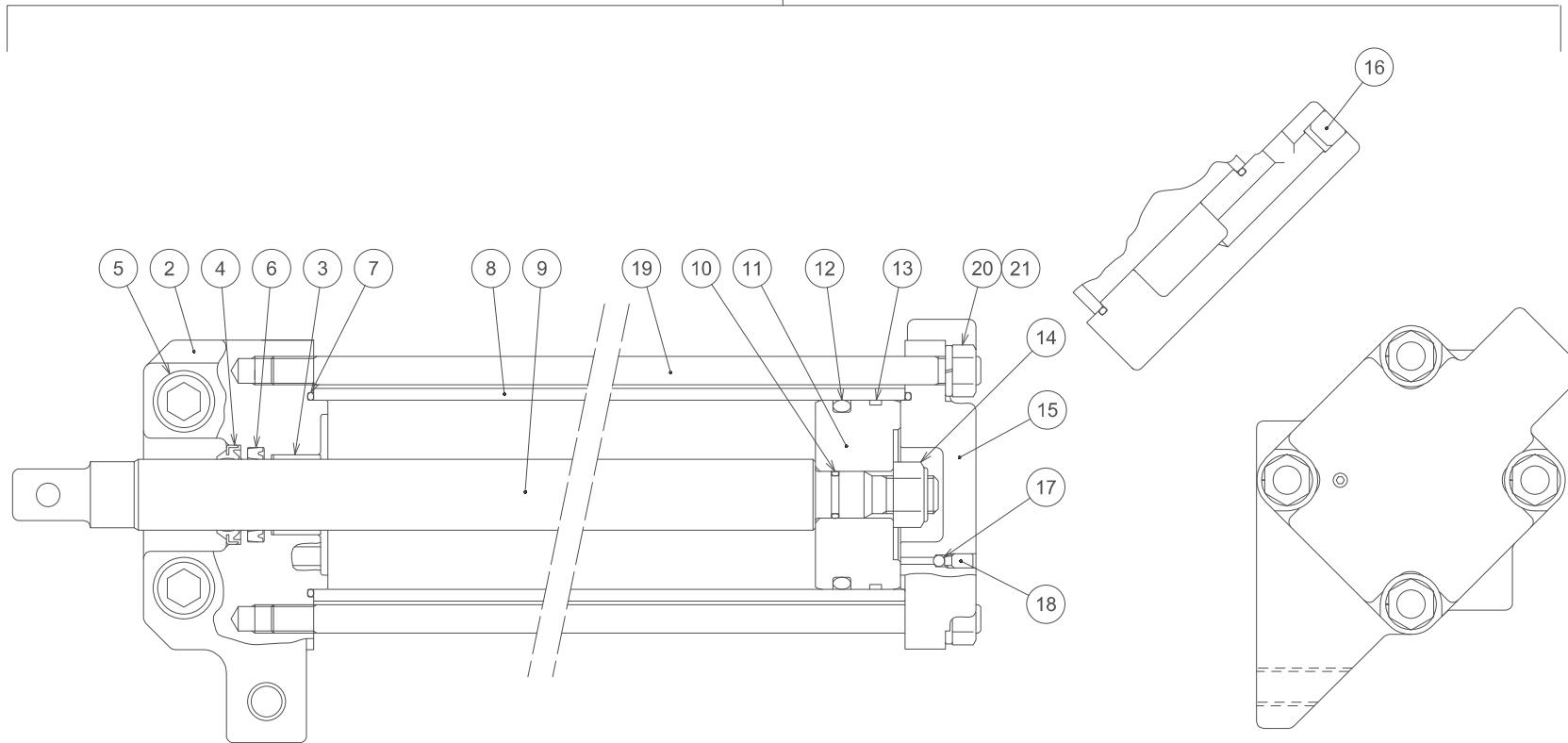

Unit No. 13
Machine Body(5)

Index	Code	Parts Name	Drawing No.	Type	Maker	Q'ty	Note
1	10302092	Vise Cylinder ASSY	SBS0125---			1	with Index 2-21
2	10301171	Cylinder Cap F	1238370 A			1	
3	10300163	Plain Bearing	P407003176	DUB3020	DAIDO METAL	1	
4	10338202	Wiper Ring	P590313004	SCB-30	SAKAGAMI	1	
5	10332953	Hex Socket Cap Screw	P330260033	M16X45		2	
6	10376483	Piston Packing	P590403023	SKY-30	SAKAGAMI	1	
7	10383406	O Ring	P590012012	1A-G80	NOK	2	
8	10378290	Cylinder	1238366			1	
9	10378291	Piston Rod	1238367 A			1	
10	10589448	O Ring	P590000018	P20		1	
11	10378295	Piston	1238372			1	
12	10001114	O Ring	P590000061	P70		1	
13	10359913	Wearing	P590473021	SWB-80	SAKAGAMI	1	
14	10375004	Locking Nut	P332505010	M16(Type-1)	FUJI SEIMITSU	1	
15	10419313	Cylinder Cap R	1238884 A			1	
16	10300171	Plug for Piping	P580208021	PT-1/4		1	
17	10332944	Steel Ball (for Bearing)	P406000002	3/16	JIS	1	
18	10356511	Socket Set Screw	P330570017	M6X12(Dog-end)	JIS	1	
19	10419314	Tie Rod	1238885			4	

Unit No. 13

Machine Body(5)

Index	Code	Parts Name	Drawing No.	Type	Maker	Q'ty	Note
20	10589227	Nut	P332000007	M12	JIS	4	
21	10000829	Spring Washer	P336050008	12	JIS	4	

Unit No. 14
Machine Body(6) <Work Tray>

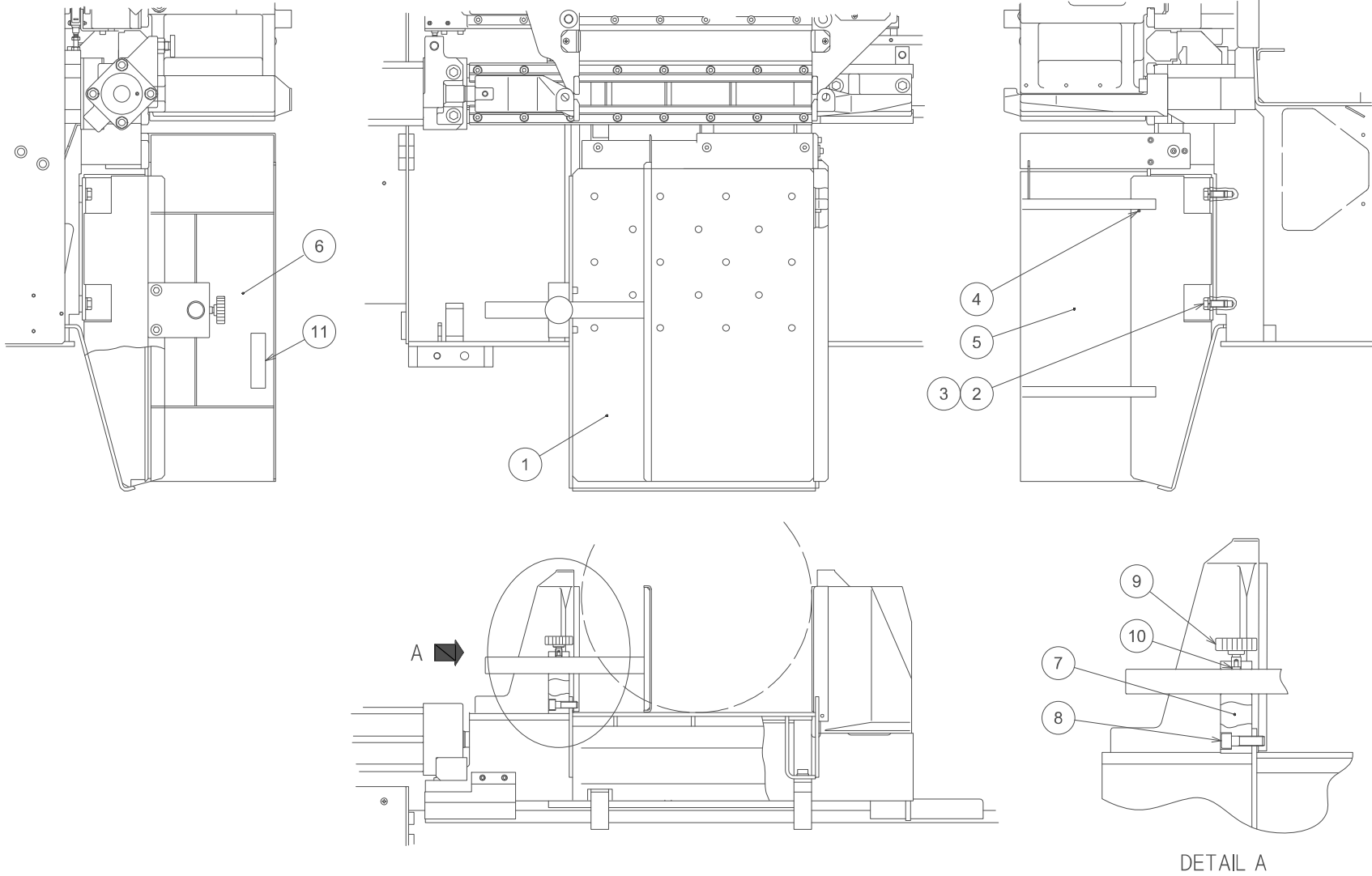

1278774--A

Unit No. 14
Machine Body(6)

Index	Code	Parts Name	Drawing No.	Type	Maker	Q'ty	Note
1	10583703	Work Tray	1238549 B			1	
2	10583704	Bolt	124469719	M12X30 12.9		4	
3	10583705	Conical Spring Washer	124469720			4	
4	10339616	Spring Pin	P337030036	5X10AW	JIS	1	
5	10583706	Fence R	1238546 C			1	
6	10583707	Fence L	1238547 B			1	
7	10378388	Bracket	1238548 A			1	
8	10328331	Hex Socket Cap Screw	P330250007	M12X40		2	
9	10301252	Lock Handle	1280595--A			1	
10	10301140	Lock Piece	0603312--A			1	
11	10301390	Sticker	RB01755--A			1	

Unit No. 15
Machine Body(7) <Control Panel Attachment>

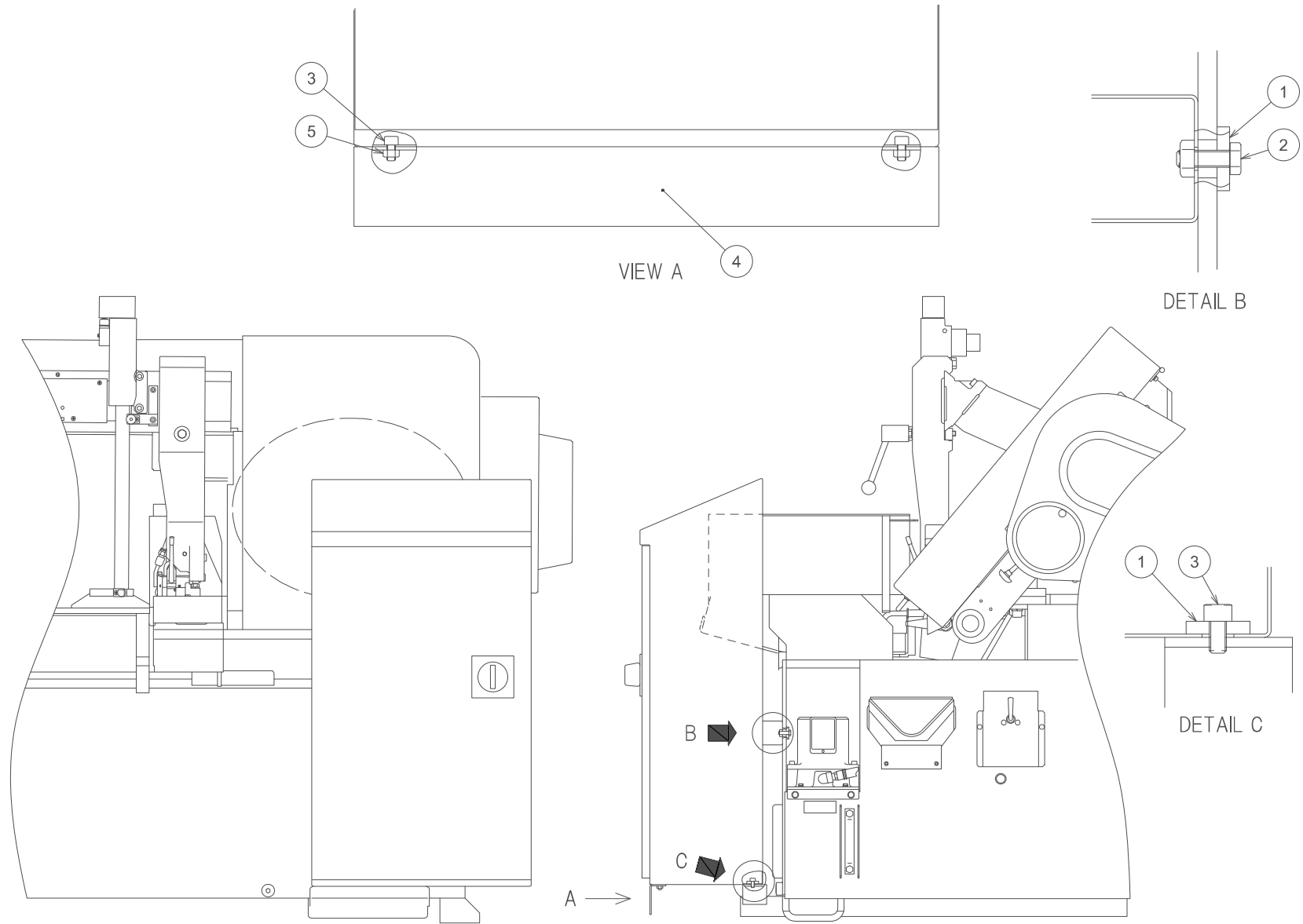

1278775--A

Unit No. 15
Machine Body(7)

Index	Code	Parts Name	Drawing No.	Type	Maker	Q'ty	Note
1	10301146	Washer	1200735--A			4	
2	10001512	Bolt	P330030007	M8X25		2	
3	10342325	Hex Socket Cap Screw	P330230004	M8X15		4	
4	10578709	Cover	1427001			1	
5	10589226	Nut	P332000005	M8	JIS	2	

Unit No. 16
Wedge-type Anchor Bolt

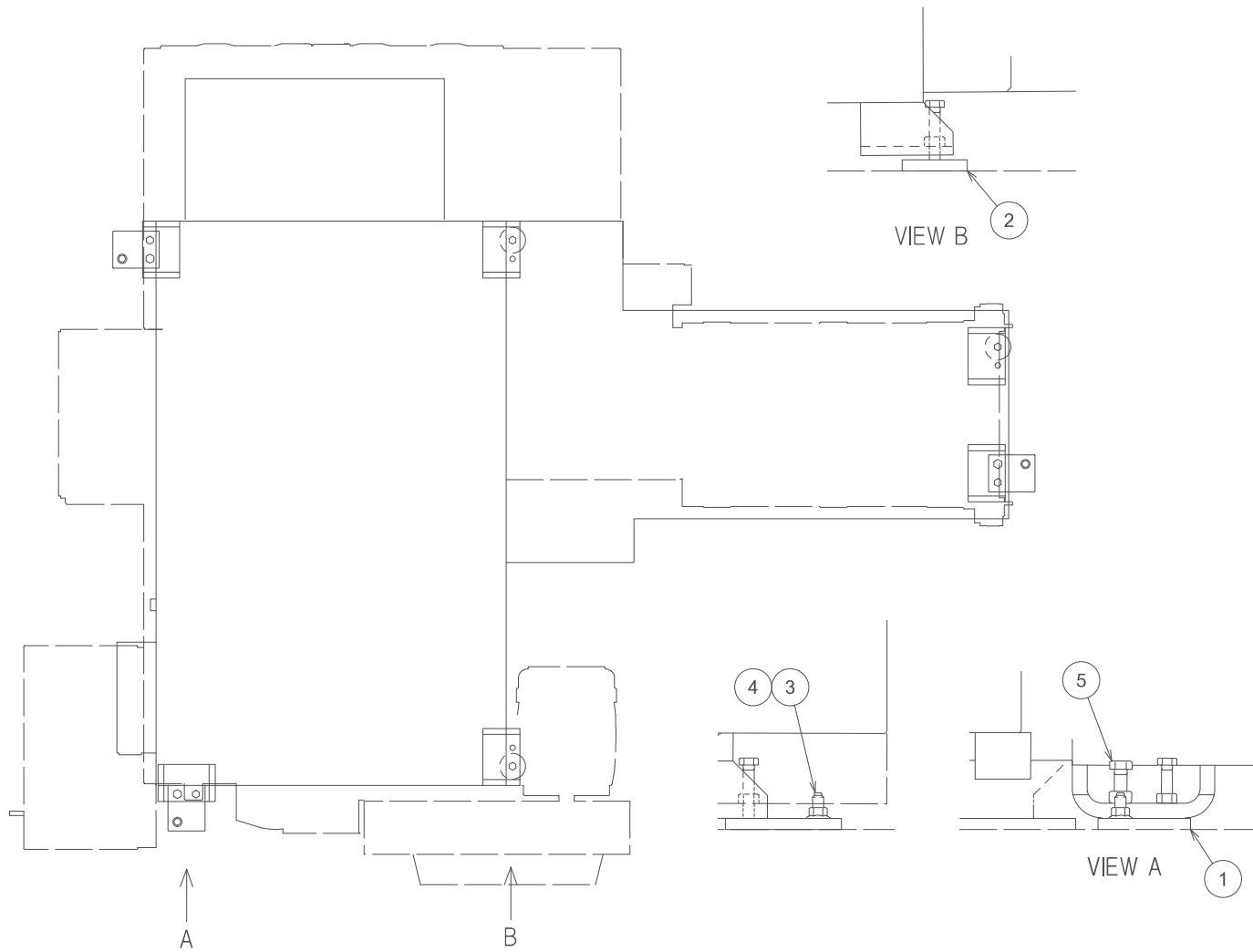

RB02485---

Unit No. 16

Wedge-type Anchor Bolt

Index	Code	Parts Name	Drawing No.	Type	Maker	Q'ty	Note
1	10300960	Anchor Plate	RB01041---			3	
2	10300961	Table Support	RB01042---			3	
3	10376113	Bolt	P330060009	M14X65(All-thread)		3	
4	10000826	Nut	P332000008	M14	JIS	3	
5	10589309	Anchor	P338213005	C-1290	SANKO Technology	3	

Unit No. 17
Drive Wheel Speed Reducer(1)-1/2

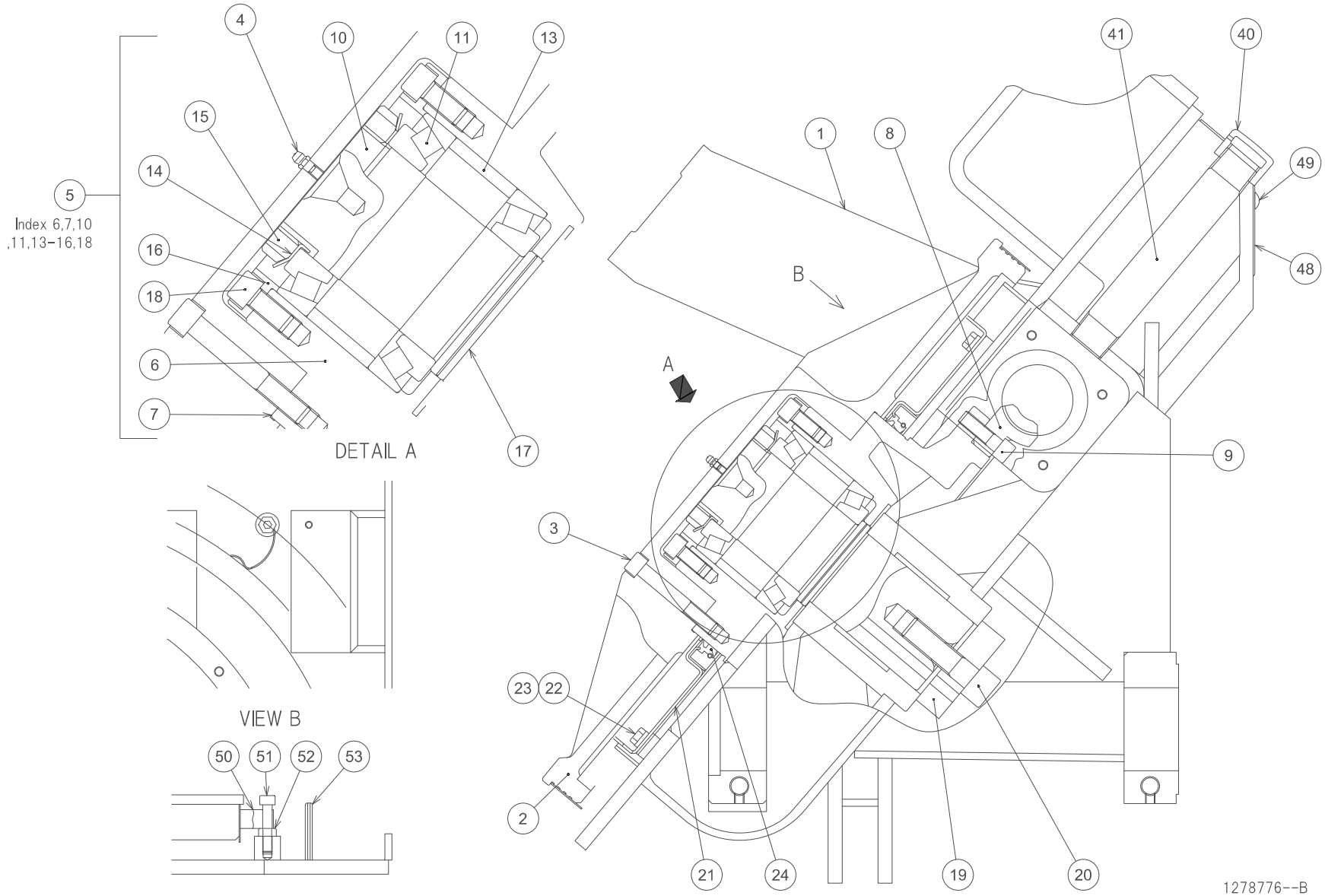

1278776--B

Unit No. 17
Drive Wheel Speed Reducer(1)-2/2

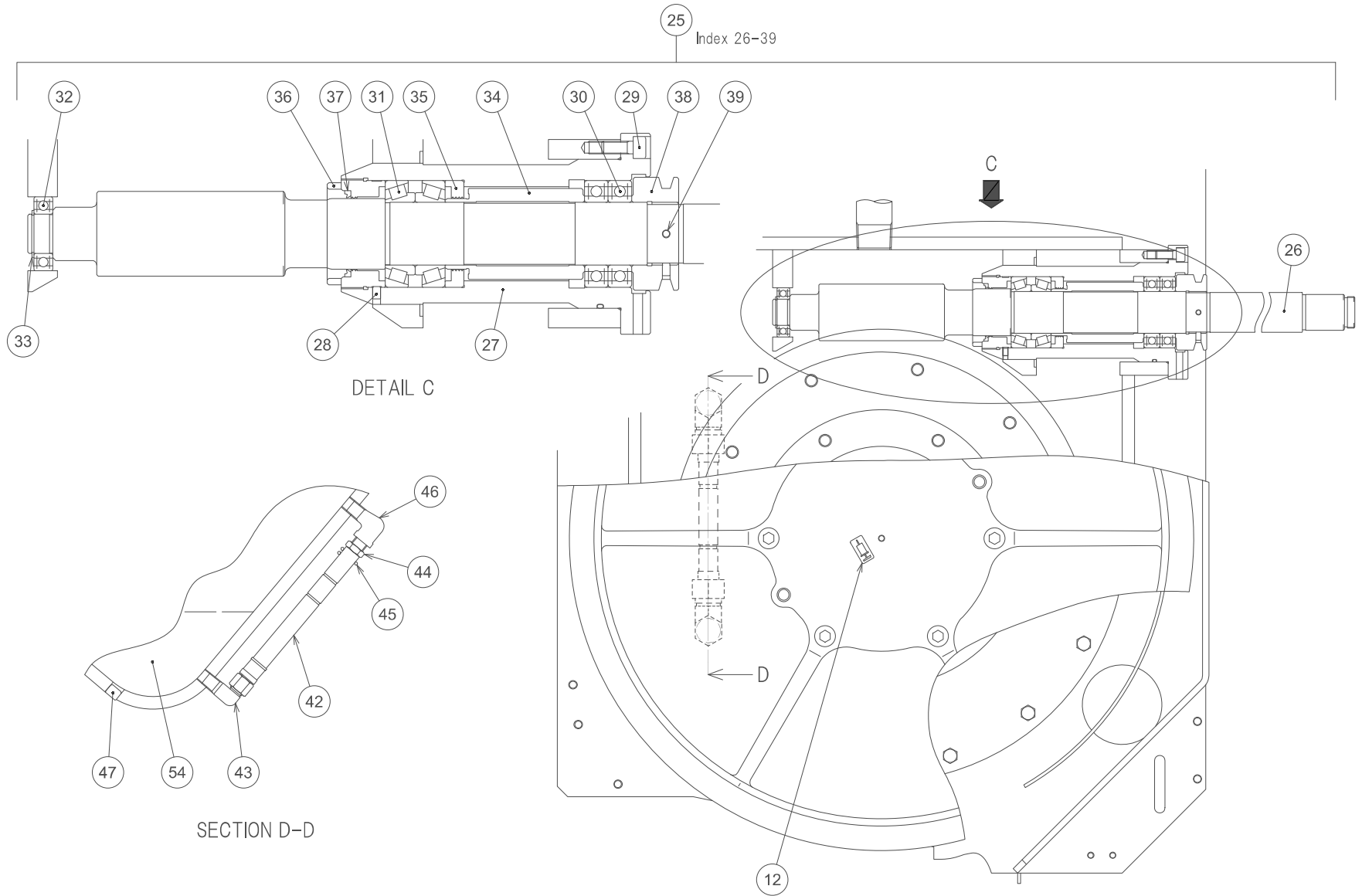

1278776--B

Unit No. 17

Drive Wheel Speed Reducer(1)

Index	Code	Parts Name	Drawing No.	Type	Maker	Q'ty	Note
1	10301439	Housing Machine ASSY	RB01773--B			1	
2	10311114	Drive Wheel	1230110 A			1	
3	10000830	Hex Socket Cap Screw	P330250015	M12X80		6	
4	10419913	Grease Nipple	P560600002	A-MT6X1	JIS	1	
5	10302093	Housing ASSY	SBS0126---	1230091 D, 1230088, RB01778--A others		1	
6	10380342	Worm Housing	1230091 D			1	
7	10322525	Shim	1230088			1	
8	10311127	Worm Wheel	1230092 B			1	
9	10328331	Hex Socket Cap Screw	P330250007	M12X40		10	
10	10301440	Driving Shaft	RB01778--A			1	
11	10323108	Taper Roller Bearing	P402010544	HR30215J	NSK(equality)	2	
12	10323010	Name Plate	0852250			1	
13	10322521	Distance Collar	1230066 B			1	
14	10301442	Locking Washer	RB0179901-	75		1	GB/T858
15	10301443	Lock Nut	RB0179902-	M75X2		1	GB/T812
16	10322517	Adjusting Collar	1230079 C			1	
17	10322541	Spacer	1230068 A			1	
18	10341333	Hex Socket Cap Screw	P330250004	M12X25		4	
19	10321917	Washer	1230069 D			1	

Unit No. 17

Drive Wheel Speed Reducer(1)

Index	Code	Parts Name	Drawing No.	Type	Maker	Q'ty	Note
20	10323213	Hex Socket Cap Screw	P330270009	M20X70		1	
21	10322542	Mission Cover	1230070 E			1	
22	10325826	Bolt	P330030006	M8X20		13	
23	10323045	Gasket	P590608001	SM-8	ITO Industry	13	
24	10301302	Oil Seal	P590112008	TB24028019	NOK	1	
25	10302094	Worm Shaft ASSY	SBS0127---	1230101 C, 1230099 C others		1	with Index 26-39
26	10311135	Worm Shaft	1230101 C			1	
27	10380352	Bearing Case	1230099 C			1	
28	10324222	Socket Set Screw	P330590012	M5X8(Dimple Type)	JIS	2	
29	10322202	Hex Socket Cap Screw	P330230006	M8X20		4	
30	10324023	Deep Groove Ball Bearing	P400010545	6008VV	NSK & others	2	
31	10324015	Taper Roller Bearing	P402010505	HR32008XJ	NSK & others	2	
32	10380358	Deep Groove Ball Bearing	P400010527	6005ZZ	NSK & others	1	
33	10310821	Locating Snap Ring	P406108046	STW-25	OCHIAI	1	
34	10322407	Collar	1230097			1	
35	10322406	Collar	1230096 A			1	
36	10322401	Screw	1230095			1	
37	10380361	Oil Seal for Bearing	P406134002	G45X55X4	NTN	1	
38	10322421	Wire Brush Pulley	1230100			1	

Unit No. 17

Drive Wheel Speed Reducer(1)

Index	Code	Parts Name	Drawing No.	Type	Maker	Q'ty	Note
39	10324222	Socket Set Screw	P330590012	M5X8(Dimple Type)	JIS	2	
40	10322544	Cap	1230085			1	
41	10322545	Nipple	1230086 A			1	
42	10583587	Level Hose	1230077 B			1	
43	10301301	Hose Adapter	P589222238	1033-PT1/4-PF1/4	The Yokohama Rubber	1	
44	10205212	Vinyl Hose Connector	0800087 A			1	
45	10380357	Hose Band	P381008029	AK-1016	SUGITAVALVE	1	
46	10359921	Elbow	P580050011	1/4(Male-Female)	JIS	1	
47	10300171	Plug for Piping	P580208021	PT-1/4		1	
48	10301441	Wiring Cover	RB01793--A			1	
49	10340019	Truss Head Screw	P334130012	M6X12	JIS	2	
50	10310913	Spring Holder	0604077 A			1	
51	10323207	Hex Socket Cap Screw	P330230010	M8X40		1	
52	10001517	Nut	P332000064	M8(Type-1)	JIS	1	
53	10334628	Spring Pin	P337030071	6X60AW	JIS	1	
54	10419315	Gear Oil	QZZ036531	SP320 5.5LITER	NISSEKI	1	

Unit No. 18
Drive Wheel Speed Reducer(2) <HA400W>

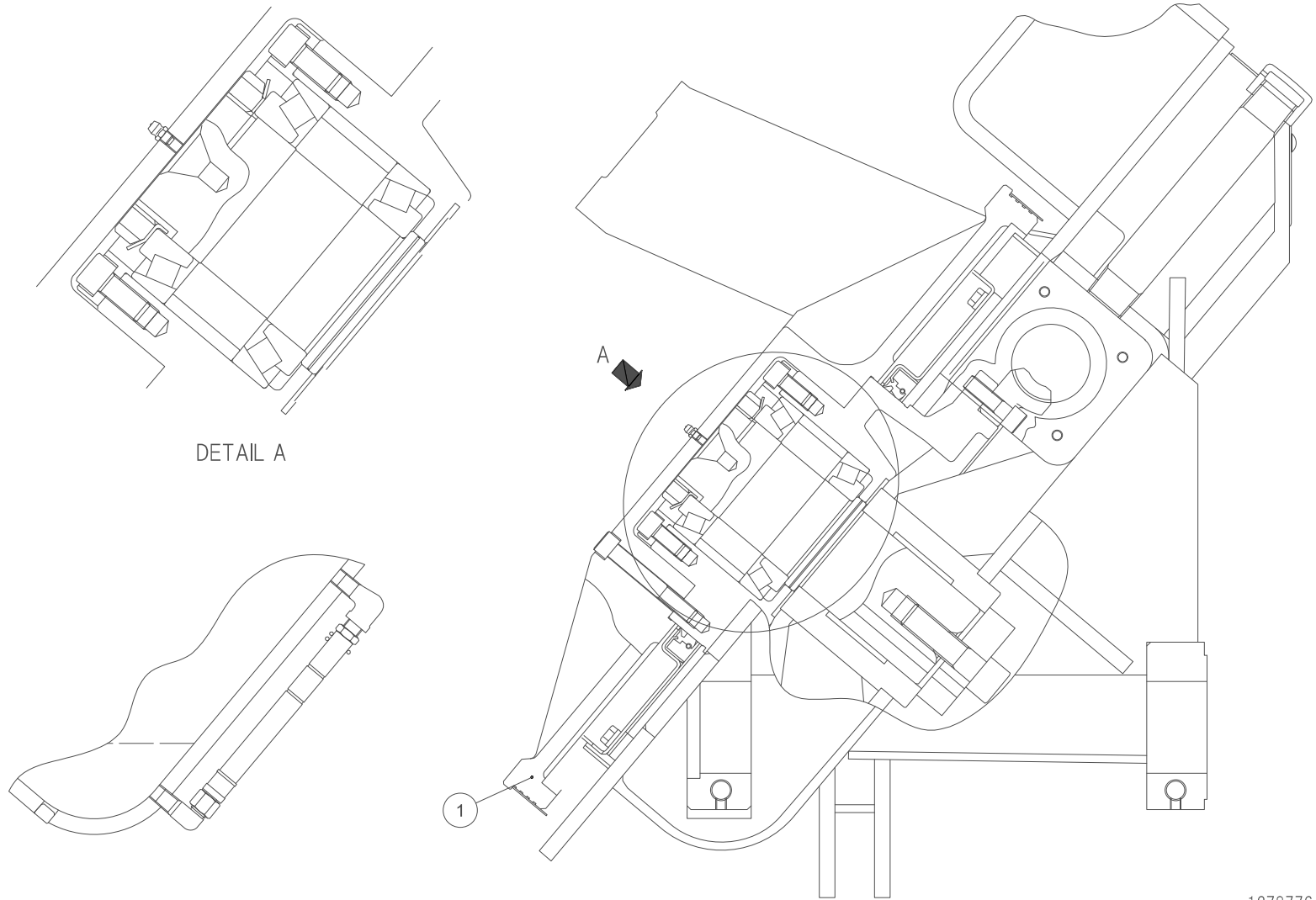

1278776--B

Unit No. 18

Drive Wheel Speed Reducer(2)

Index	Code	Parts Name	Drawing No.	Type	Maker	Q'ty	Note
1	10322503	Drive Wheel	1231724			1	

Unit No. 19

Drive Wheel Speed Reducer(3)-1/2 <Sawhead Cover>

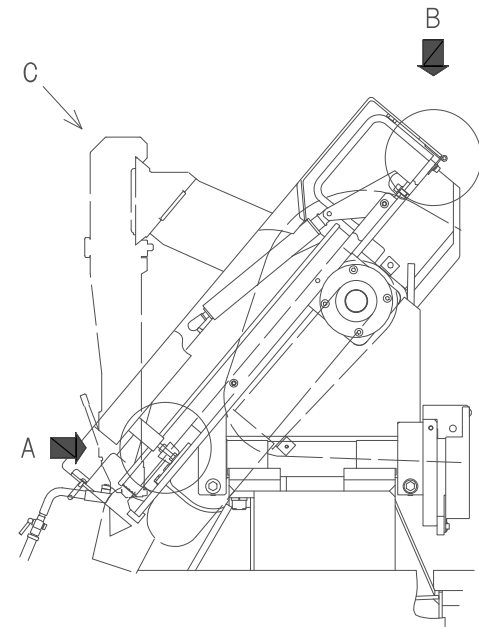
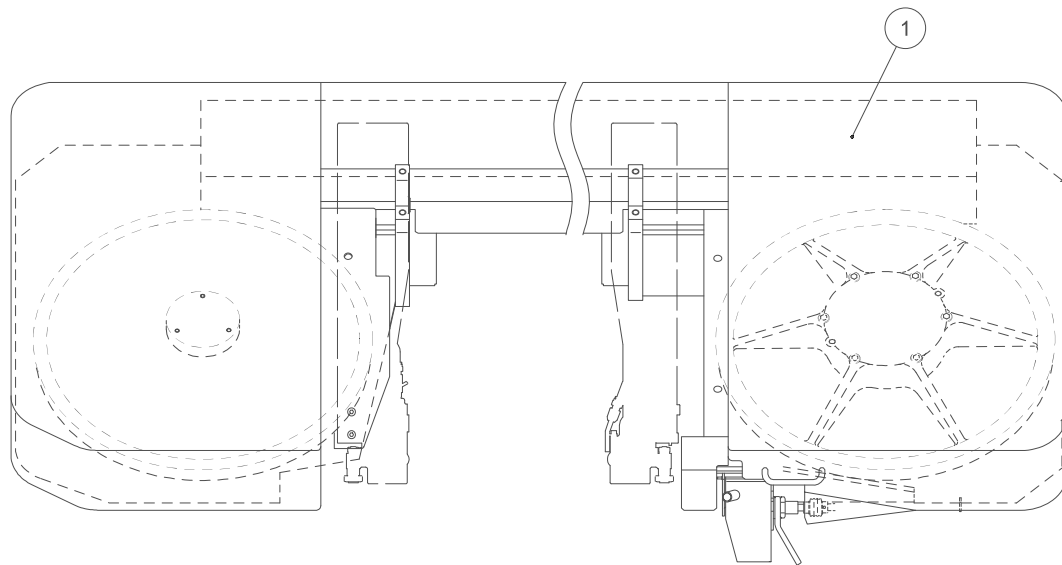
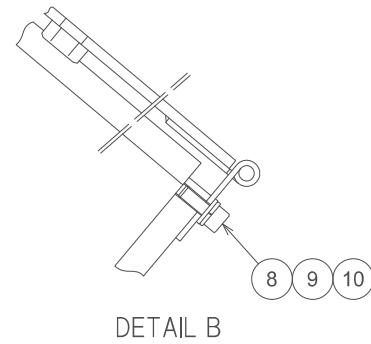
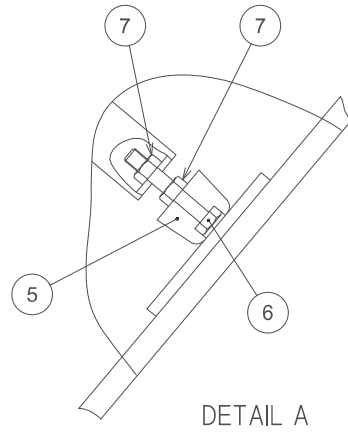

1278777---

Unit No. 19
 Drive Wheel Speed Reducer(3)-2/2 <Sawhead Cover>

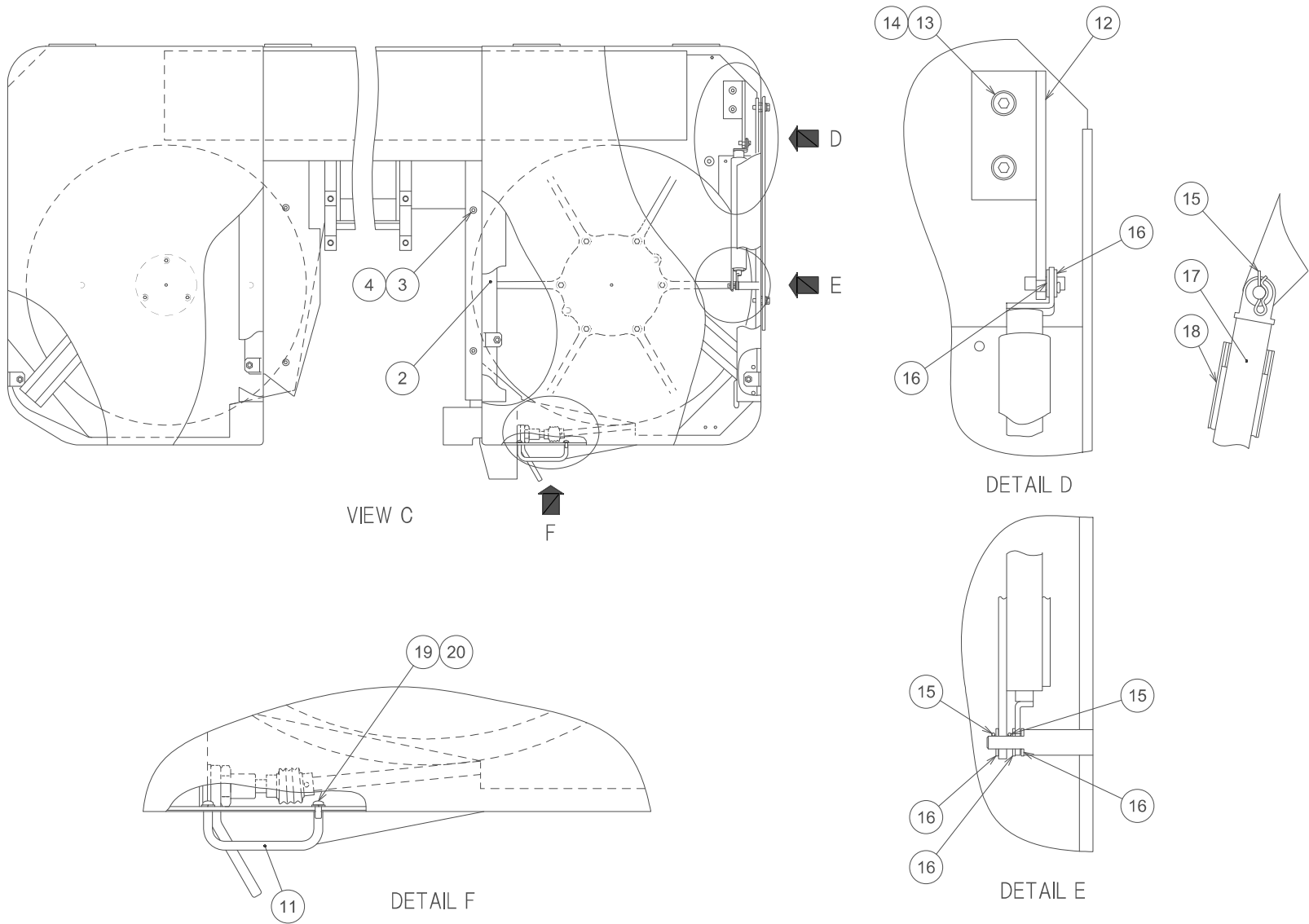

1278777---

Unit No. 19

Drive Wheel Speed Reducer(3)

Index	Code	Parts Name	Drawing No.	Type	Maker	Q'ty	Note
1	10583588	Wheel Cover	1230657 H			1	
2	10583589	Drive Sub Cover	1230656 B			1	
3	10322202	Hex Socket Cap Screw	P330230006	M8X20		2	
4	10321923	Washer	P336000006	8(Normal)	JIS	2	
5	10583590	Vibration Isolator	124469701A			4	
6	10322262	Bolt	P330030016	M8X50(All-thread)	MOURI	4	
7	10589226	Nut	P332000005	M8	JIS	8	
8	10323204	Hex Socket Cap Screw	P330220007	M6X16	JIS	8	
9	10321922	Washer	P336000005	6(Normal)	JIS	8	
10	10310351	Spring Washer	P336050005	6	JIS	8	
11	10583591	Grip	124469702B		CHI-HUEI	1	
12	10583592	Hinge Bracket	1238786 C			1	
13	10343103	Hex Socket Cap Screw	P330230005	M8X16	JIS	2	
14	10001521	Spring Washer	P336050006	8	JIS	2	
15	10301285	Pine Needle Pin	P337078001	SSP-8(SWB/White)	OCHIAI	3	
16	10321923	Washer	P336000006	8(Normal)	JIS	5	
17	10583593	Gas Spring	124469703		LIFT MASTER	1	
18	10380365	Gas Spring Cover	1238077 B			1	
19	10583594	Screw for Grip	124469731			2	

Unit No. 19

Drive Wheel Speed Reducer(3)

Index	Code	Parts Name	Drawing No.	Type	Maker	Q'ty	Note
20	10310351	Spring Washer	P336050005	6	JIS	2	

Unit No. 20
Gearbox(1)-1/2

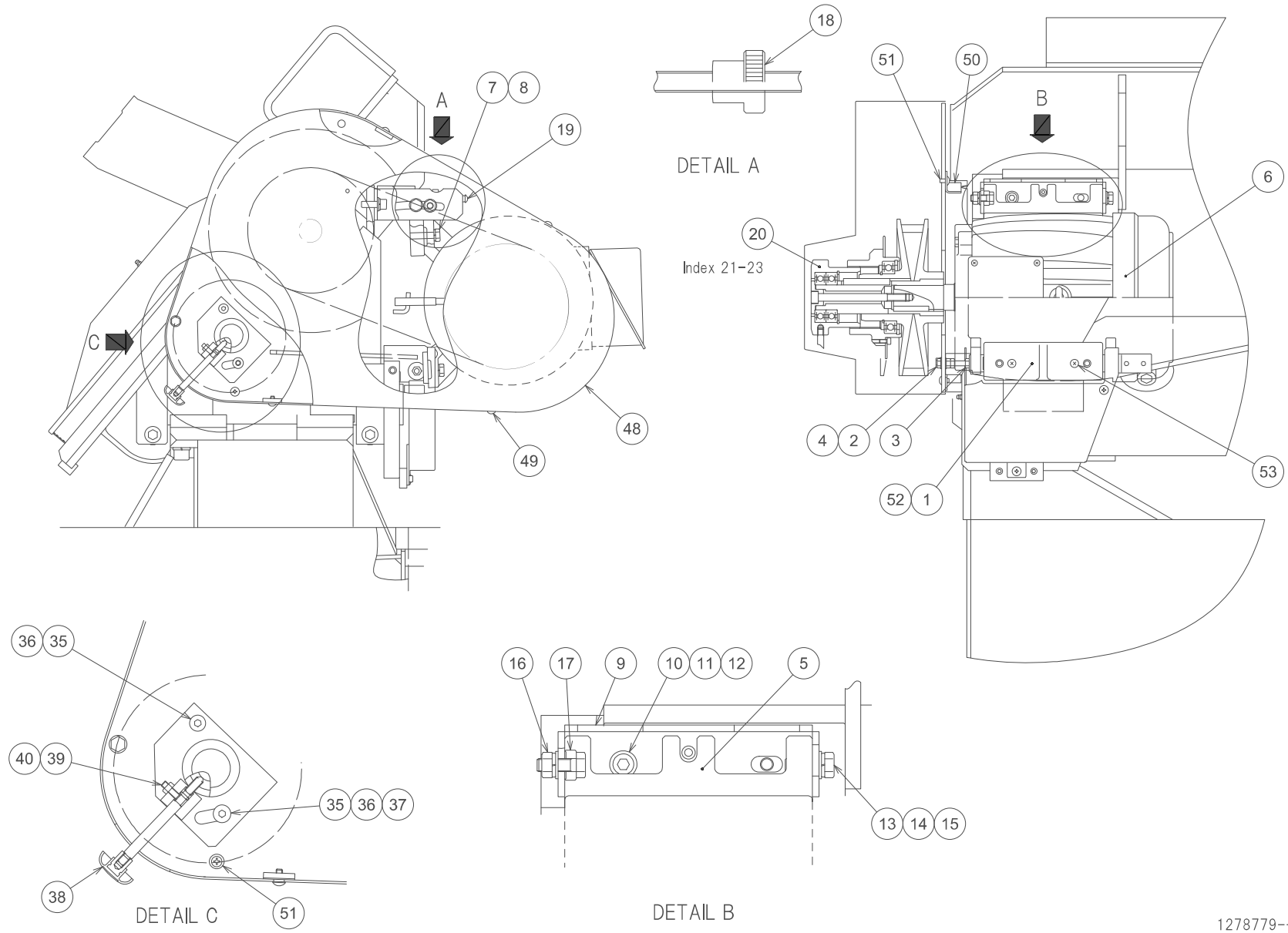

1278779--B

Unit No. 20
Gearbox(1)-2/2

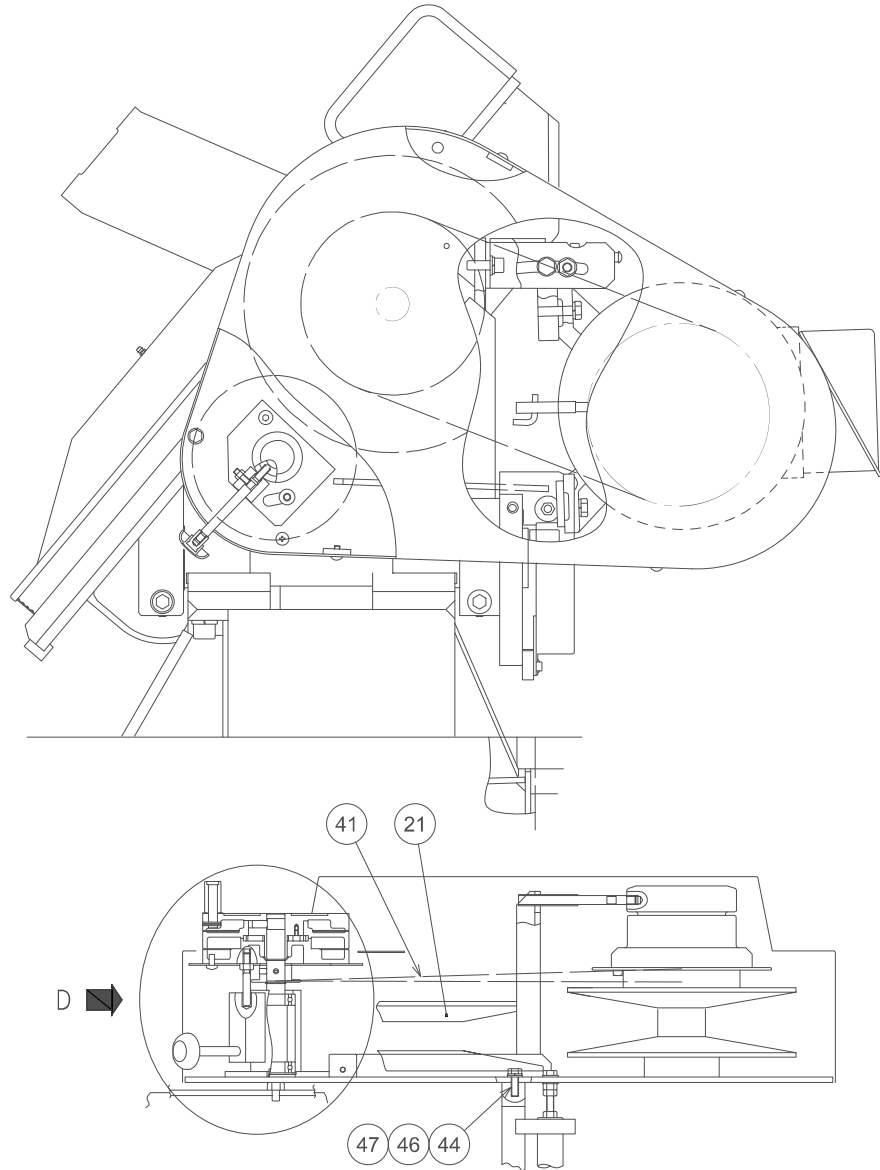
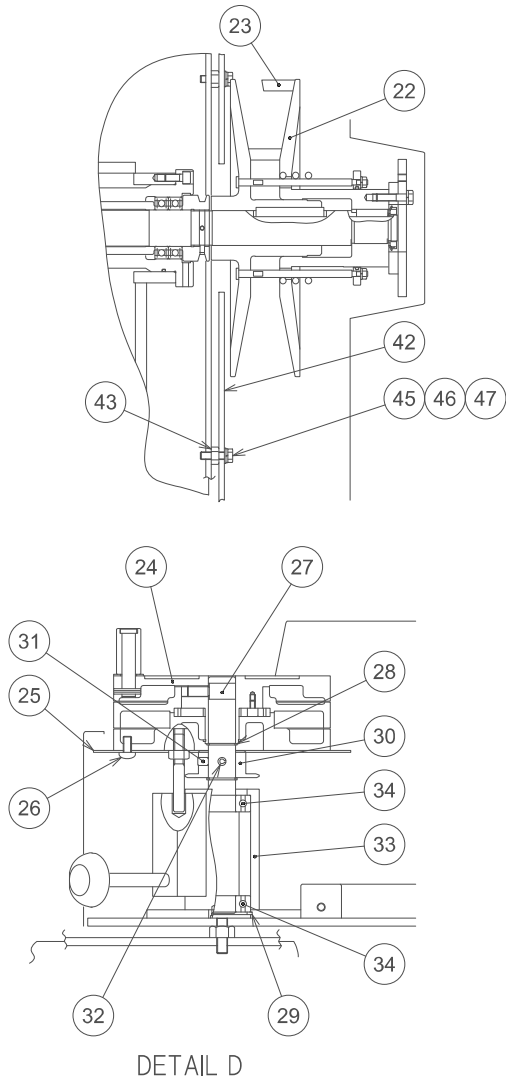

1278779--B

Unit No. 20
Gearbox(1)

Index	Code	Parts Name	Drawing No.	Type	Maker	Q'ty	Note
1	10301447	Hinge Shaft	RB01821--A			1	
2	10325413	Bolt	P330030018	M8X60		1	
3	10589226	Nut	P332000005	M8	JIS	3	
4	10321923	Washer	P336000006	8(Normal)	JIS	2	
5	10301448	Motor Base	RB01822--A			1	
6	10301449	Saw Blade Motor	RB01823--A	Y2-132S-4 B3(5.5kW)		1	Y2-132S-4 B3(5.5Kw)
7	10329658	Bolt	P330040007	M10X40		4	
8	10001520	Spring Washer	P336050007	10	JIS	4	
9	10301450	Motor Bracket	RB01824--A			1	
10	10322207	Hex Socket Cap Screw	P330240008	M10X30		2	
11	10325021	Washer	P336000007	10(Normal)	JIS	2	
12	10001520	Spring Washer	P336050007	10	JIS	2	
13	10325410	Bolt	P330040005	M10X30		3	
14	10325021	Washer	P336000007	10(Normal)	JIS	3	
15	10001520	Spring Washer	P336050007	10	JIS	3	
16	10427991	Nut	P332000006	M10	JIS	1	
17	10325022	Bite Type Washer	1230158 A			1	
18	10324331	Nut (with Knob)	1230156			1	
19	10340019	Truss Head Screw	P334130012	M6X12	JIS	1	

Unit No. 20
Gearbox(1)

Index	Code	Parts Name	Drawing No.	Type	Maker	Q'ty	Note
20	10301271	Variable Speed Drive	7922539--A	PDS-55-03-N	Miki Pulley	1	with Index 21-23
21	10301273	Drive Pulley	792253902	AK-250-G-N	Miki Pulley	1	
22	10301274	Driven Pulley	792253903	PE-325-B	Miki Pulley	1	
23	10583598	Belt	792253904	2322V521	Miki Pulley	1	
24	10301275	Index Handle ASSY	7922540 A	SD-160-F-N	Miki Pulley	1	mm
24	10381224	Index Handle ASSY	7922541 A	SD-160-G-N	Miki Pulley	1	inch
25	10380382	Handle Cover	1230157 A			1	
26	10322226	Pan Head Screw	P334100055	M6X12	JIS	3	
27	10419324	Handle Shaft	1230147 D			1	
28	10001102	Locating Snap Ring	P406108043	STW-20	OCHIAI	2	
29	10301293	Locating Snap Ring	P406108014	RTW-42	OCHIAI	1	
30	10323755	Sprocket Wheel	1230150 A			1	
31	10322120	Socket Set Screw	P330590018	M6X8(Dimple Type)	JIS	1	
32	10322110	Spring Pin	P337030065	6X35AW	OHKITA	1	
33	10380383	Handle Bracket	1238114 B			1	
34	10301288	Deep Groove Ball Bearing	P400010517	6004ZZ	NSK & others	2	
35	10322202	Hex Socket Cap Screw	P330230006	M8X20		2	
36	10001521	Spring Washer	P336050006	8	JIS	2	
37	10321923	Washer	P336000006	8(Normal)	JIS	1	

Unit No. 20
Gearbox(1)

Index	Code	Parts Name	Drawing No.	Type	Maker	Q'ty	Note
38	10583599	Lock Knob	1230149 C			1	
39	10323230	Socket Set Screw	P330570020	M6X20(Dog-end)	JIS	1	
40	10589225	Nut	P332000004	M6	JIS	1	
41	10310150	Chain	1230152 A			1	
42	10301451	Rear Cover	RB01836--A			1	
43	10356524	Nut	P332000032	M10(Type-1)	JIS	2	
44	10001512	Bolt	P330030007	M8X25		1	
45	10325408	Bolt	P330030008	M8X30		2	
46	10001521	Spring Washer	P336050006	8	JIS	3	
47	10321923	Washer	P336000006	8(Normal)	JIS	3	
48	10583602	Cover	1230629 B			1	
49	10340019	Truss Head Screw	P334130012	M6X12	JIS	4	
50	10583603	V-belt Cover	1230155			1	
51	10340019	Truss Head Screw	P334130012	M6X12	JIS	2	
52	10301452	Spacer	RB01839--C			1	
53	10443238	Flat Head Screw	P334110029	M6X16	JIS	2	

Unit No. 21

Gearbox(2) <Power Source Voltage:400V>

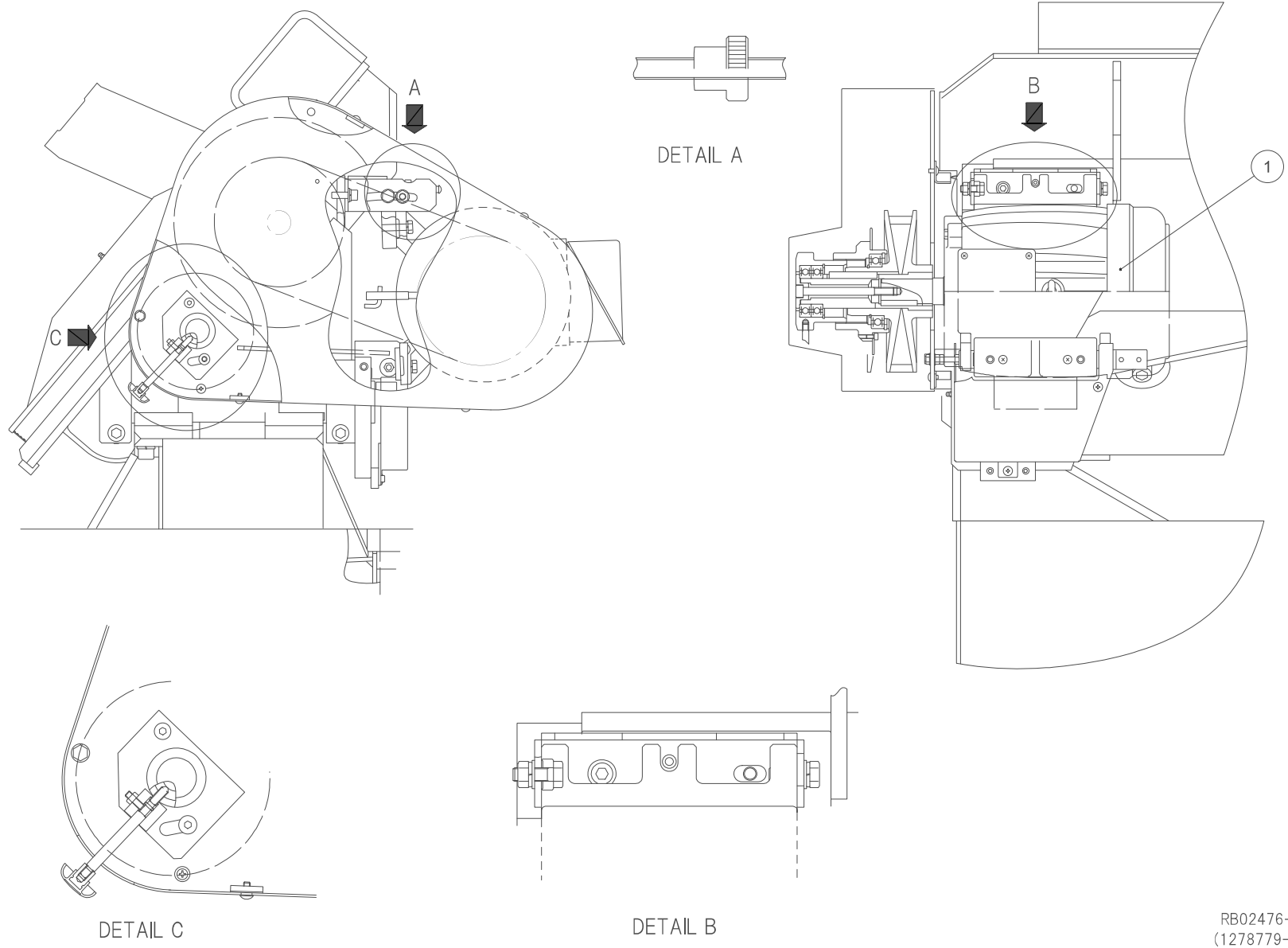

Unit No. 21
Gearbox(2)

Index	Code	Parts Name	Drawing No.	Type	Maker	Q'ty	Note
1	10301523	Saw Blade Motor 400V	RB02476--A			1	5.5KW 4P400V

Unit No. 22

Gearbox(3) <Power Source Voltage:230/460V>

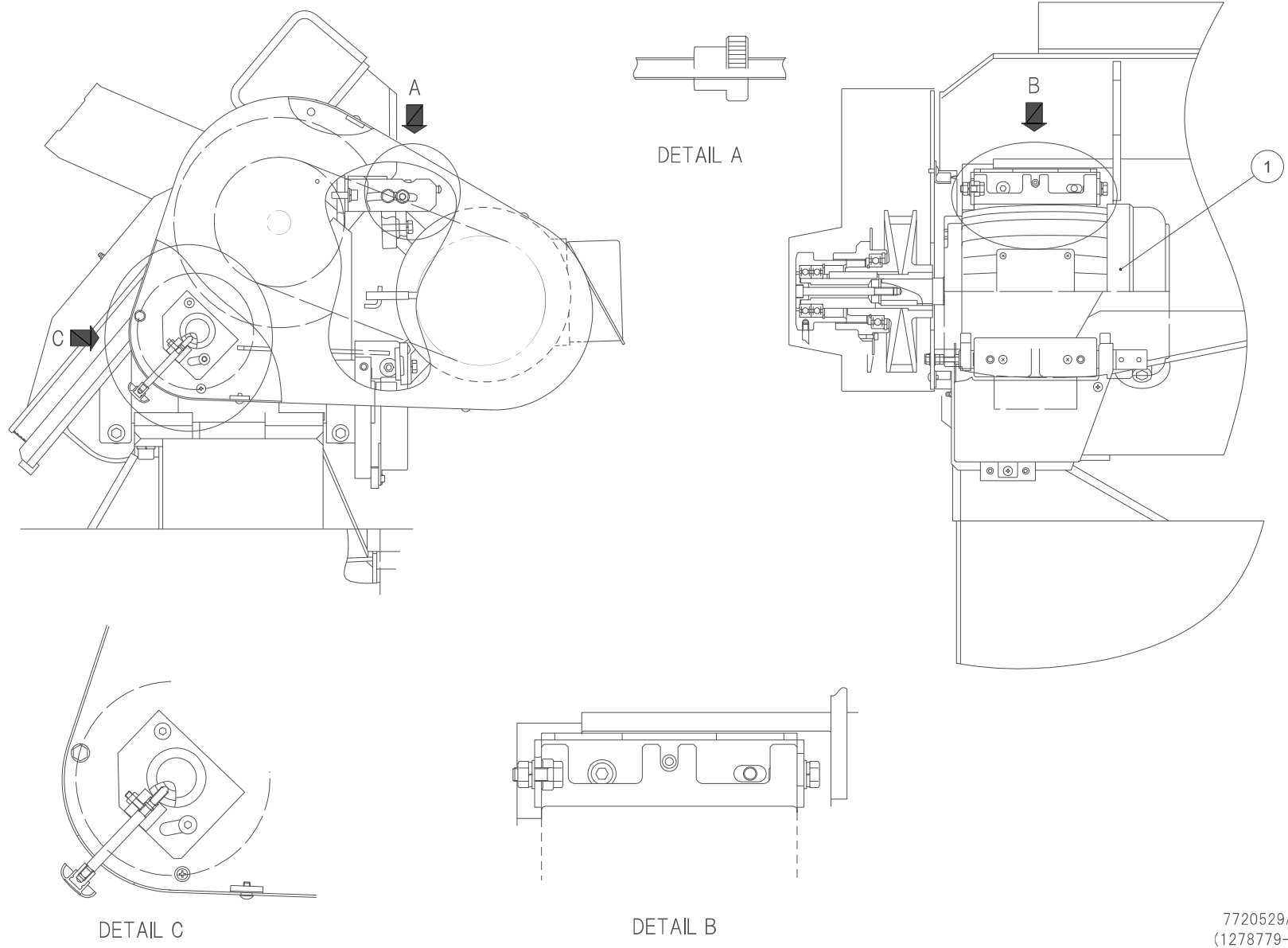

7720529A
(1278779--B)

Unit No. 22

Gearbox(3)

Index	Code	Parts Name	Drawing No.	Type	Maker	Q'ty	Note
1	10583596	Saw Blade Motor	7720529 A			1	5.5KW 4P230/460V

Unit No. 23
 Driven Wheel(1)-1/2

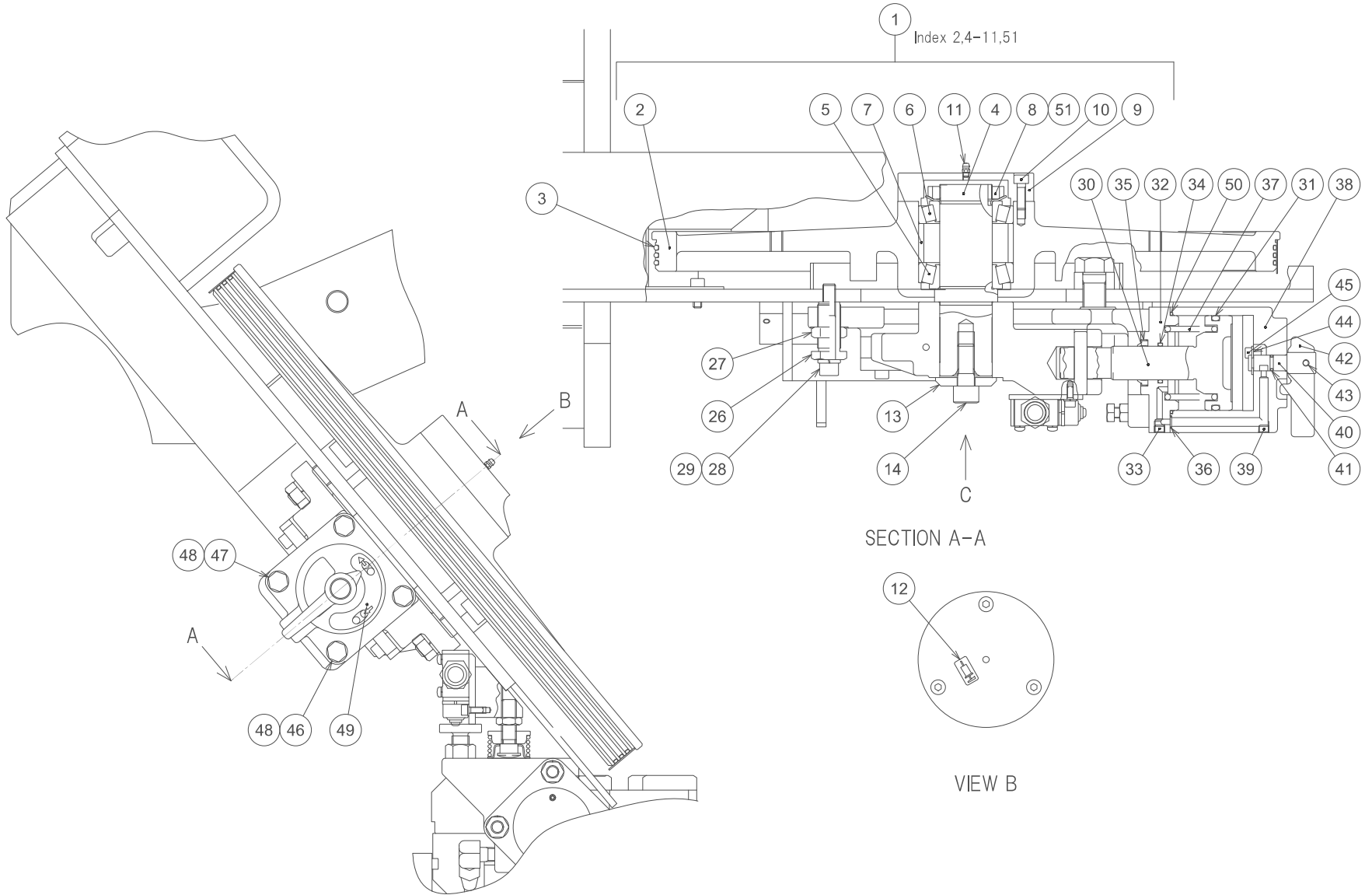

1278780--B

Unit No. 23
Driven Wheel(1)-2/2

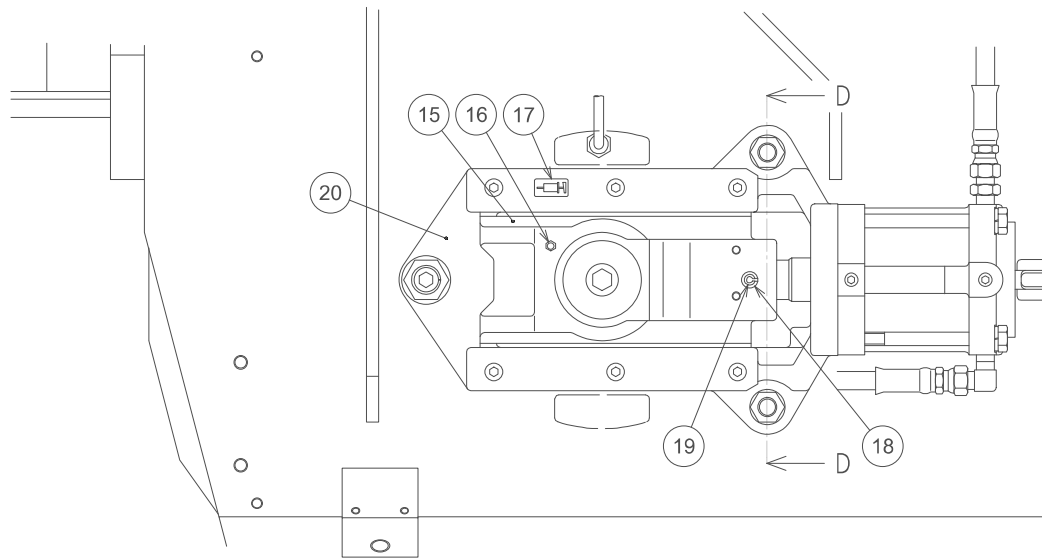

VIEW C

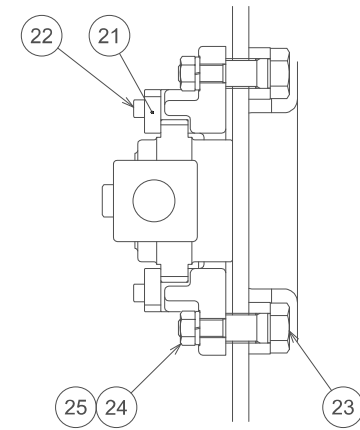

SECTION D-D

1278780--B

Unit No. 23
Driven Wheel(1)

Index	Code	Parts Name	Drawing No.	Type	Maker	Q'ty	Note
1	10302095	Driven Wheel ASSY	SBS0128---	1238159 A, RB01843--A, 1260155 B others		1	with Index 2,4-11,51
2	10583604	Idle Wheel	1238159 A			1	
3	10311214	Polyurethane Rope	0636547 C	D4X1730L		3	
4	10301453	Third Shaft	RB01843--A			1	
5	10301292	Taper Roller Bearing	P402010538	HR32210J	NSK(equality)	1	
6	10301291	Taper Roller Bearing	P402010537	HR30210J	NSK(equality)	1	
7	10378109	Bearing Collar	1238160 A			1	
8	10301445	Lock Nut	RB0179904-	M50X1.5		1	GB/T812
9	10378110	Bearing Cap	1260155 B			1	
10	10322202	Hex Socket Cap Screw	P330230006	M8X20		3	
11	10419913	Grease Nipple	P560600002	A-MT6X1	JIS	1	
12	10323010	Name Plate	0852250			1	
13	10311923	Washer	0601903 A			1	
14	10323211	Hex Socket Cap Screw	P330260032	M16X40		1	
15	10418961	Slide Piece	1230182 B			1	
16	10419913	Grease Nipple	P560600002	A-MT6X1	JIS	1	
17	10323010	Name Plate	0852250			1	
18	10326005	Spring Pin	P337038006	SPP-12X60	OCHIAI	1	
19	10326004	Spring Pin	P337030086	8X60AW	OHKITA	1	

Unit No. 23
Driven Wheel(1)

Index	Code	Parts Name	Drawing No.	Type	Maker	Q'ty	Note
20	10418962	Tension Body	1230183 F			1	
21	10325821	Guide Plate	1230204 B			2	
22	10330101	Hex Socket Cap Screw	P330230008	M8X30		6	
23	10325839	Reamer Bolt M22	1230184 B			2	
24	10000826	Nut	P332000008	M14	JIS	2	
25	10000825	Spring Washer	P336050009	14	JIS	2	
26	10311928	Adjust Bolt	0601892 A			1	
27	10389578	Adjusting Nut	0800113 A			1	
28	10332952	Hex Socket Cap Screw	P330250014	M12X75	MOURI	1	
29	10000829	Spring Washer	P336050008	12	JIS	1	
30	10325842	Piston	1230185 A			1	
31	10316808	O Ring	P590000064	P80		1	
32	10325968	Cylinder Cap	1230186 B			1	
33	10380409	Plug for Piping	P580208022	PT-1/8		1	
34	10317827	O Ring	P590000033	P32		1	
35	10326120	Wiper Ring	P590312005	DKI-32	NOK	1	
36	10314519	O Ring	P590000007	P9		1	
37	10301148	Tension Cylinder Spring	1230191 A			1	
38	10325835	Cylinder	1230187 B			1	

Unit No. 23
Driven Wheel(1)

Index	Code	Parts Name	Drawing No.	Type	Maker	Q'ty	Note
39	10380409	Plug for Piping	P580208022	PT-1/8		1	
40	10312050	Rotary Valve	1230188 B			1	
41	10206605	O Ring	P590000010	P11		1	
42	10312035	Valve Lever	1230189 A			1	
43	10326108	Socket Set Screw	P330570016	M6X10(Dog-end)	JIS	1	
44	10312046	Stopper Plate	1230190			1	
45	10312831	Hex Socket Cap Screw	P330220006	M6X15		1	
46	10325832	Bolt	P330040029	M10X110		2	
47	10325833	Bolt	P330040040	M10X130	MOURI	2	
48	10001520	Spring Washer	P336050007	10	JIS	4	
49	10325860	Name Plate	1230192 B			1	
50	10204805	O Ring	P590010014	G90		1	
51	10301444	Locking Washer	RB0179903-	50		1	GB/T858

Unit No. 24
Driven Wheel(2) <HA400W>

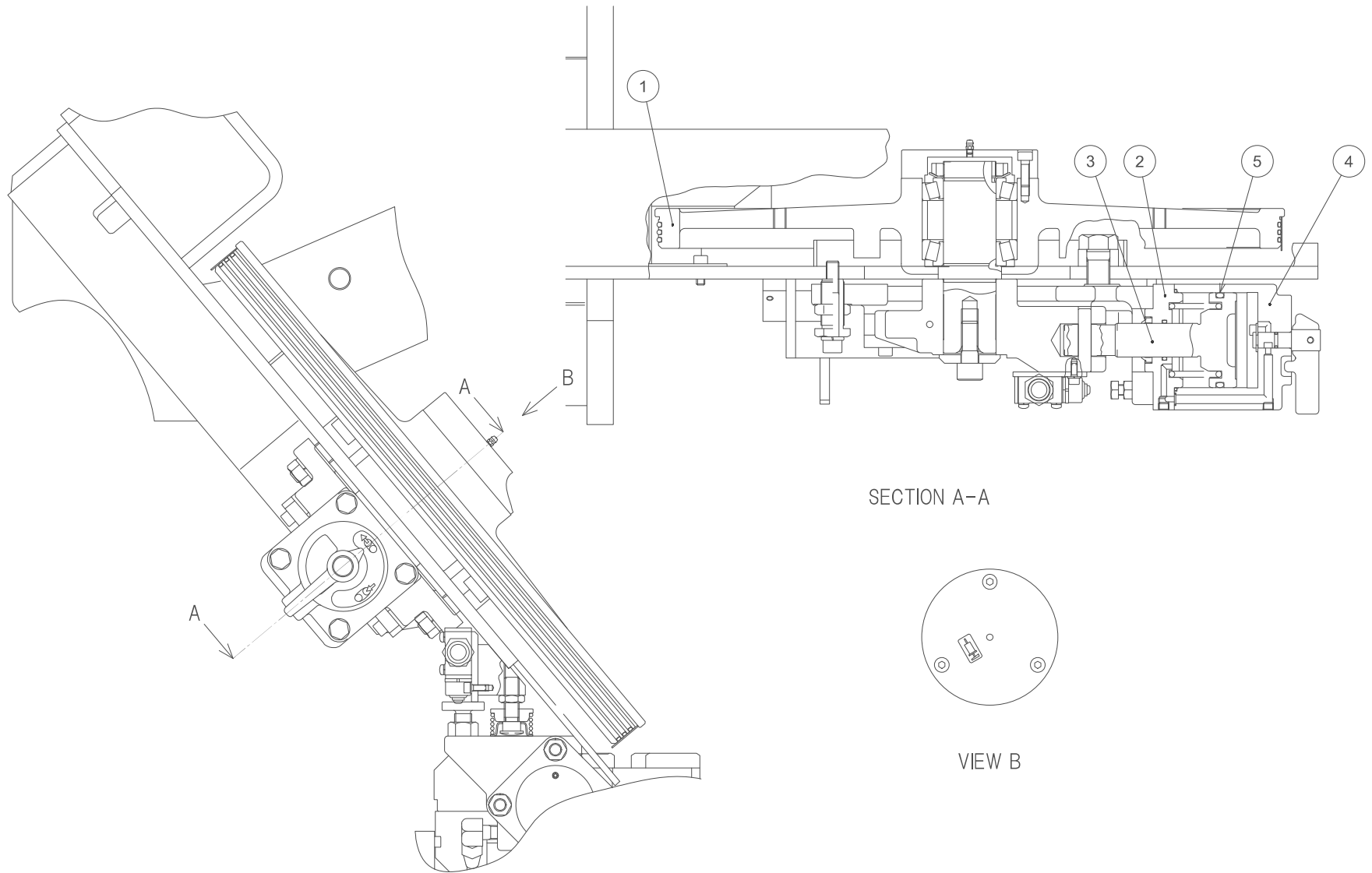

Unit No. 24
Driven Wheel(2)

Index	Code	Parts Name	Drawing No.	Type	Maker	Q'ty	Note
1	10583605	Idle Wheel	1286526 A			1	
2	10301169	Cylinder Cap	1231735 A			1	
3	10388120	Piston	1231736 A			1	
4	10325851	Cylinder	1231737			1	
5	10326106	O Ring	P590000065	P85		1	

Unit No. 25
Driven Wheel(3) <Lower Limit Stopper>

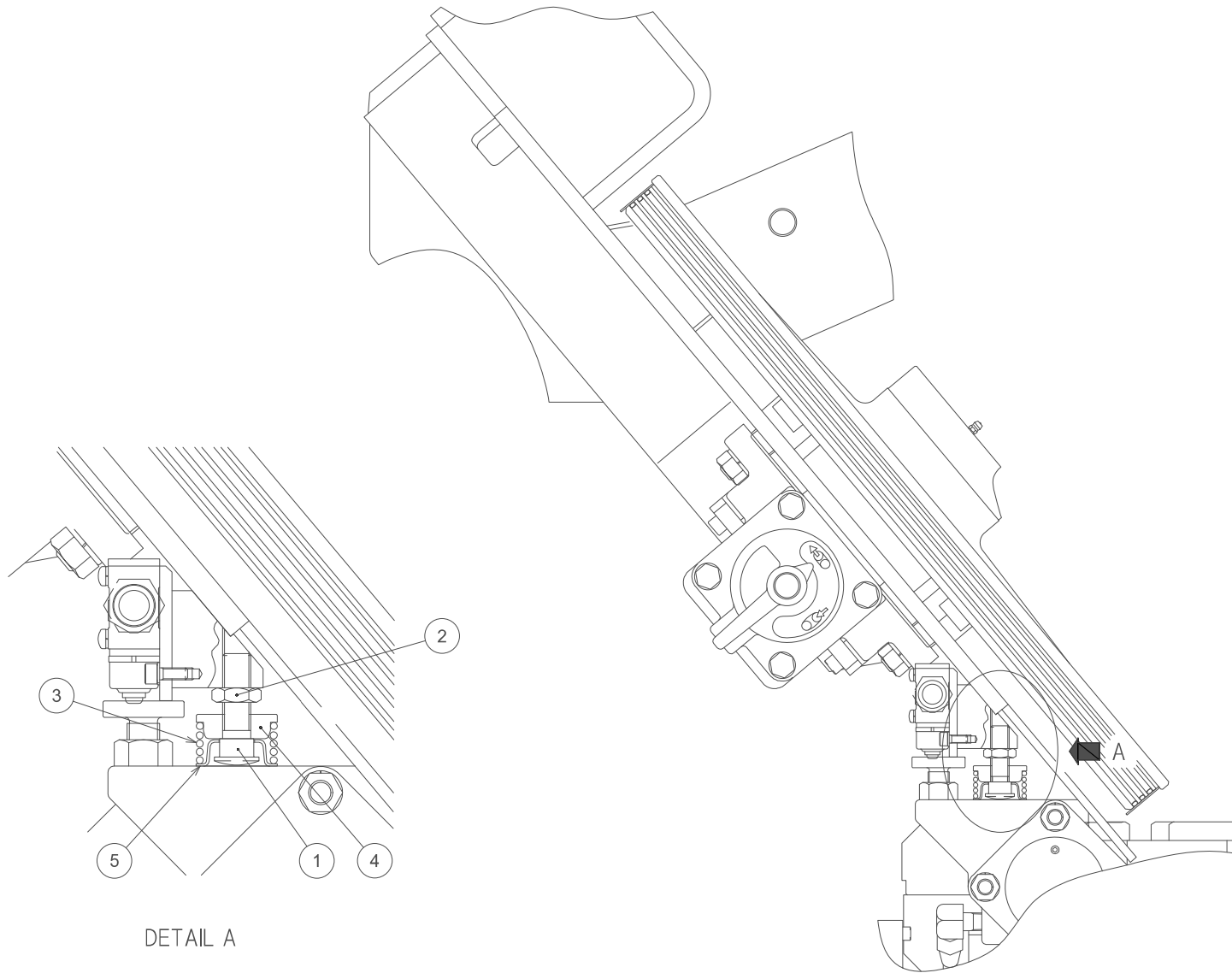

1278781---
(1278780--B)

Unit No. 25
Driven Wheel(3)

Index	Code	Parts Name	Drawing No.	Type	Maker	Q'ty	Note
1	10583607	Stopper Bolt	1230631 B			1	
2	10323102	Nut	P332000107	M14(Type-3)	JIS	1	
3	10325940	Spring	7023480			1	
4	10325945	Stopper Nut	7023481			1	
5	10325947	Spring Support	7023482			1	

Unit No. 26
Driven Wheel(4) <Limit Switch>

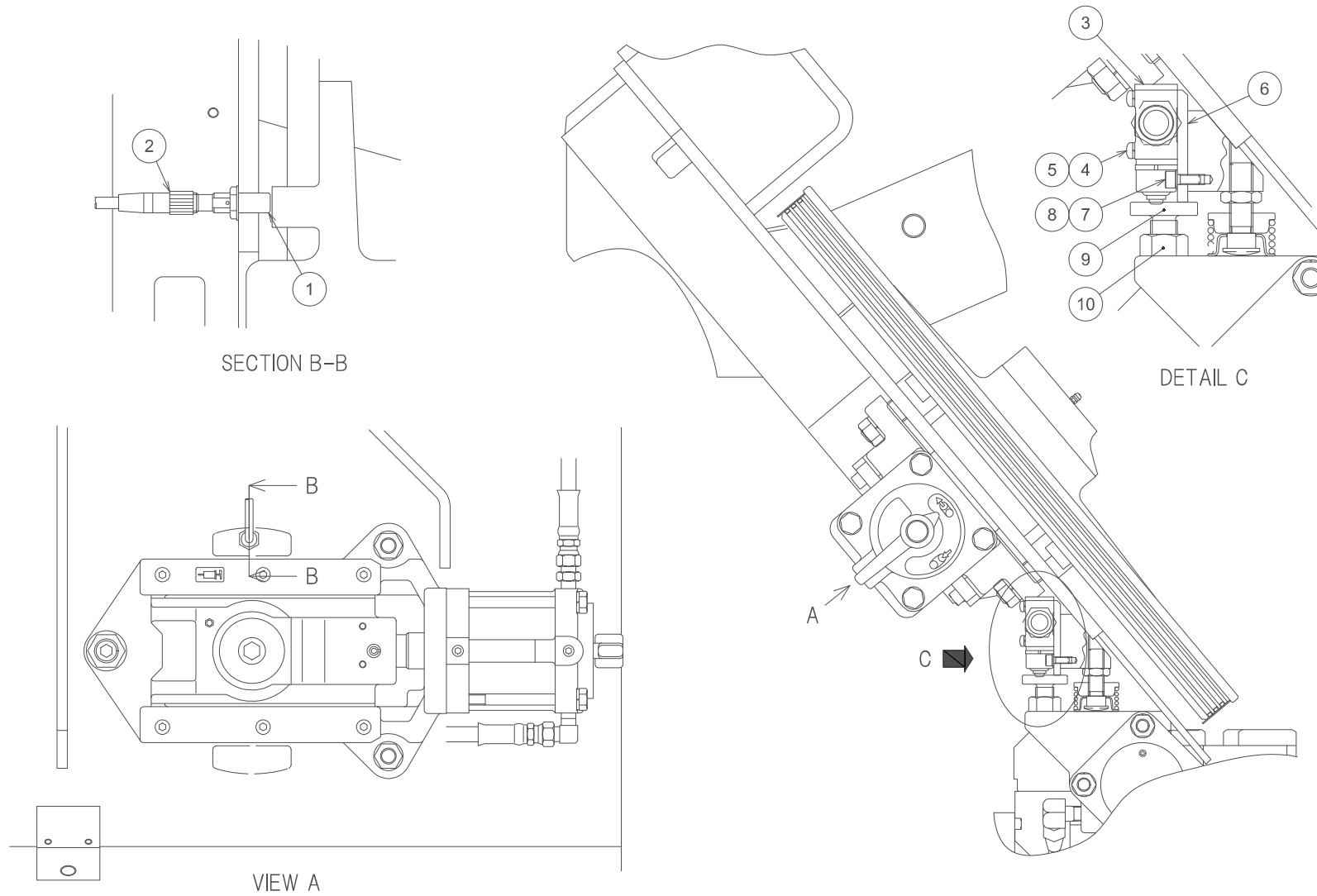

1278783--A
(1278780--B)

Unit No. 26
Driven Wheel(4)

Index	Code	Parts Name	Drawing No.	Type	Maker	Q'ty	Note
1	10381502	Proximity Switch	P829003100	FL7M-3J6HD-CN	YAMATAKE	1	
2	10380397	Accessory for Proximity Switch	P829133006	PA5-4ISX3HK	YAMATAKE	1	
3	10318541	Limit Switch	P828012030	ZV2-N-2	OMRON	1	
4	10377210	Pan Head Screw	P334100046	M5X30	JIS	2	
5	10322215	Spring Washer	P336050004	5	JIS	2	
6	10583608	LS Bracket	1230632 C			1	
7	10323204	Hex Socket Cap Screw	P330220007	M6X16	JIS	2	
8	10420817	Conical Spring Washer	P336165001	CDW-6H	HHK	2	
9	10386029	Touch Bolt	1238219			1	
10	10001515	Nut	P332000066	M16(Type-1)	JIS	1	

Unit No. 27
Driven Wheel(5) <Blade Guard>

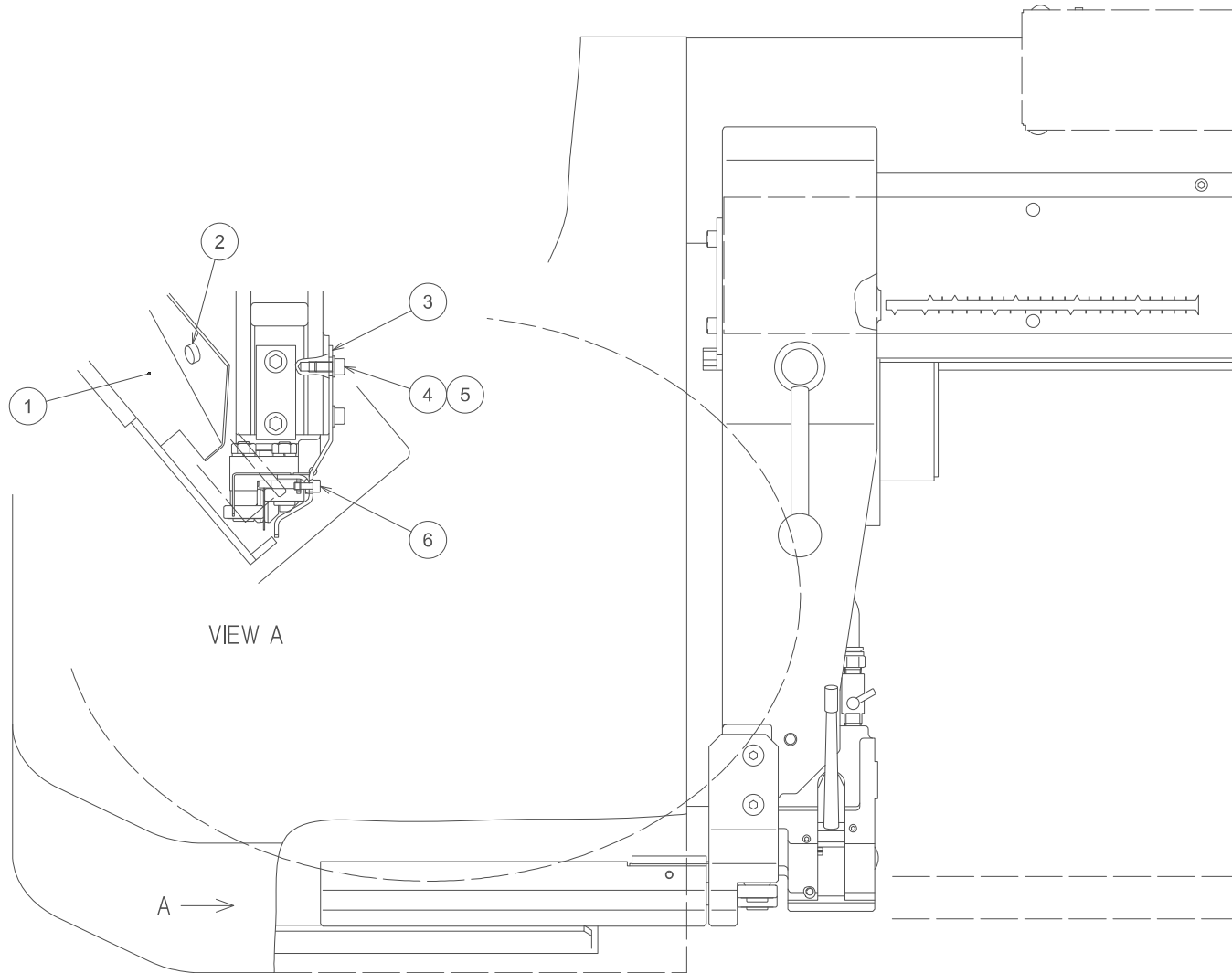

1278782--A

Unit No. 27

Driven Wheel(5)

Index	Code	Parts Name	Drawing No.	Type	Maker	Q'ty	Note
1	10583609	Driven Support Cover	1230658 B			1	
2	10322202	Hex Socket Cap Screw	P330230006	M8X20		2	
3	10583610	Blade Guard	1230639			1	
4	10343103	Hex Socket Cap Screw	P330230005	M8X16	JIS	2	
5	10321923	Washer	P336000006	8(Normal)	JIS	2	
6	10322615	Hex Socket Cap Screw	1200256 A	M6X16		1	

Unit No. 28
Saw Blade Guide(1)-1/3

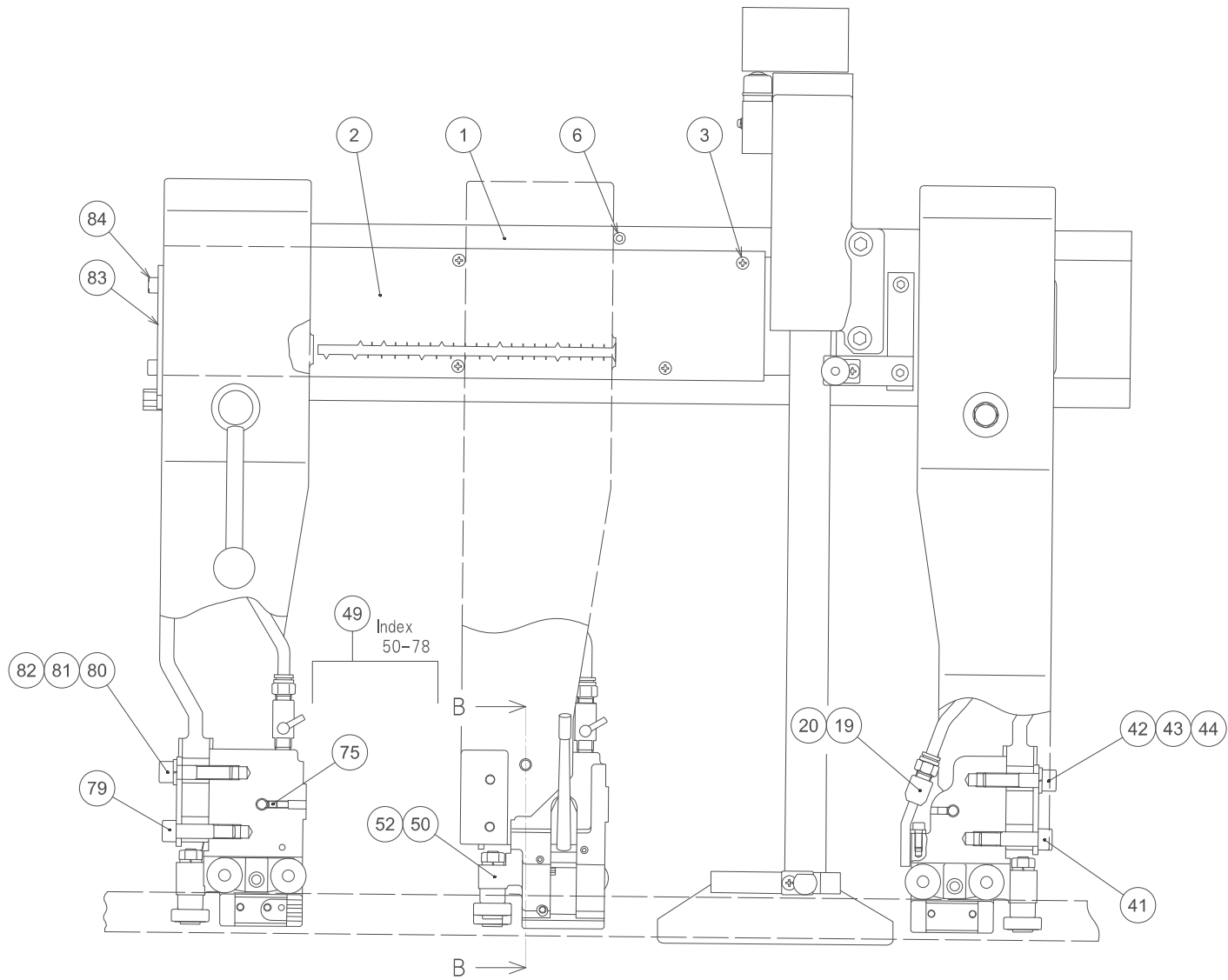

1278784--A

Unit No. 28
Saw Blade Guide(1)-2/3

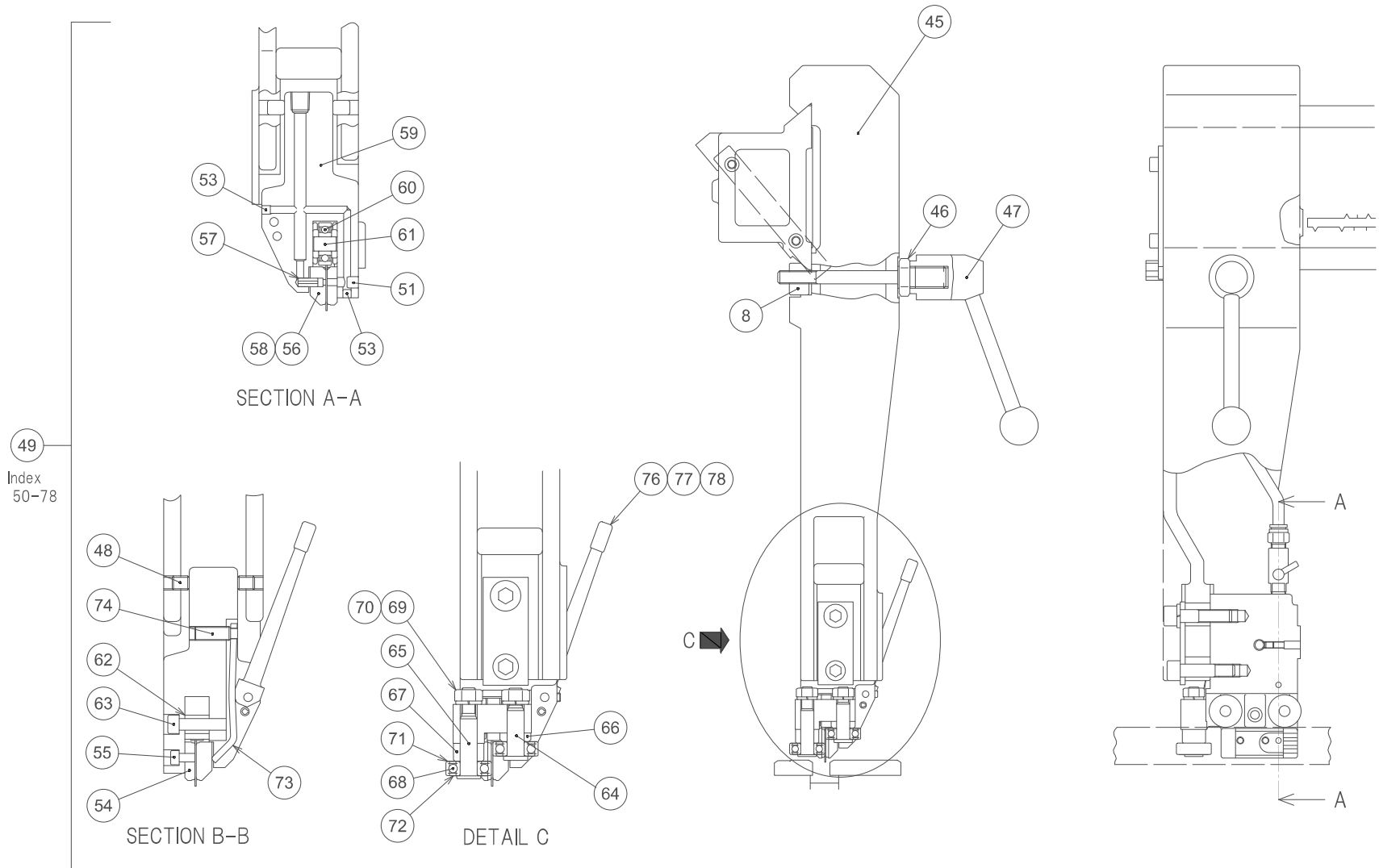

1278784--A

Unit No. 28
Saw Blade Guide(1)-3/3

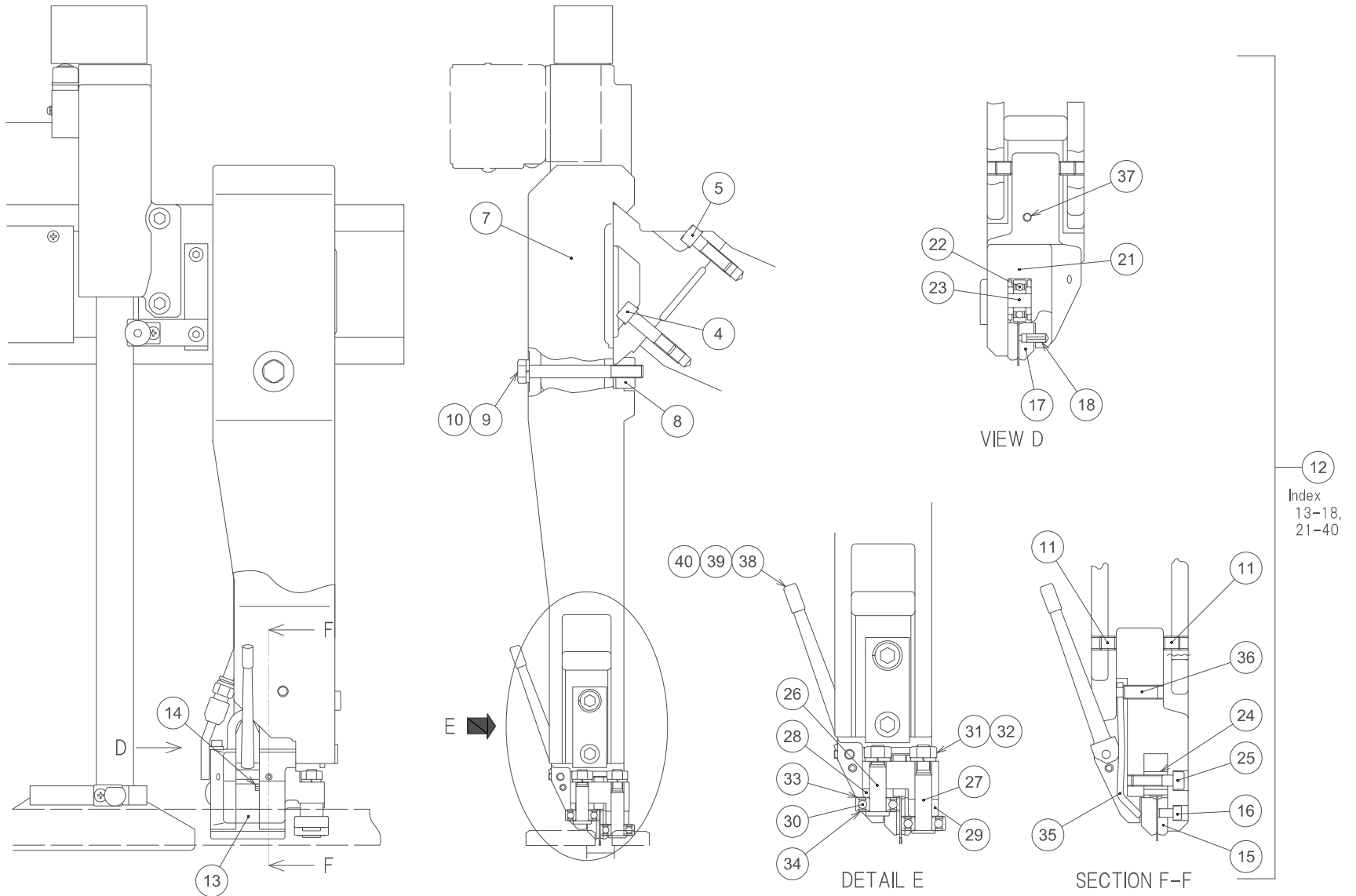

12
Index
13-18,
21-40

1278784--A

Unit No. 28

Saw Blade Guide(1)

Index	Code	Parts Name	Drawing No.	Type	Maker	Q'ty	Note
1	10583611	Guide Bar	1230651 B			1	
2	10301170	Support Plate	1238193 C			1	
3	10322226	Pan Head Screw	P334100055	M6X12	JIS	6	
4	10583617	Reamer Bolt M12	1230243 B	(M12X50)		2	L(1)/R(1)
5	10328331	Hex Socket Cap Screw	P330250007	M12X40		2	L(1)/R(1)
6	10312831	Hex Socket Cap Screw	P330220006	M6X15		1	
7	10583612	Guide Bracket R	1238216 A			1	R(Qty)'
8	10378136	Slide Chip	1238186 A			2	L(1)/R(1)
9	10325412	Bolt	P330050022	M12X100		1	R(Qty)'
10	10000829	Spring Washer	P336050008	12	JIS	1	R(Qty)'
11	10322126	Socket Set Screw	P330550049	M10X12(Flat Type)	JIS	2	R(Qty)'
12	10302096	Insert Holder R ASSY	SBS0664---	1238202, 1230250 B, 1230251 B others		1	with Index 13-18,21-40
13	10386032	Insert Holder R	1238202			1	R(Qty)'
14	10328305	Spring Pin	P337030062	6X28AW	JIS	2	L(1)/R(1)
15	10312347	Fixed Insert R	1230250 B			1	R(Qty)'
16	10589206	Hex Socket Cap Screw	P330220003	M6X10		2	R(Qty)'
17	10312349	Movable Insert R	1230251 B			1	R(Qty)'
18	10328304	Spring Pin	P337030055	6X14AW	JIS	1	R(Qty)'
19	10312539	Nozzle	1230259 D			1	R(Qty)'

Unit No. 28
Saw Blade Guide(1)

Index	Code	Parts Name	Drawing No.	Type	Maker	Q'ty	Note
20	10312831	Hex Socket Cap Screw	P330220006	M6X15		1	R(Qty)'
21	10418979	Backup Roller Holder	1230254 A			1	R(Qty)'
22	10300129	Deep Groove Ball Bearing	7922885---	6200LLU/LP03QT	NTN	2	R(Qty)'
23	10312852	Roller Pin	0637054			2	R(Qty)'
24	10385735	Sleeve	1230255 A			1	R(Qty)'
25	10330101	Hex Socket Cap Screw	P330230008	M8X30		1	R(Qty)'
26	10383828	Bearing Shaft 1	1109933			1	R(Qty)'
27	10383829	Bearing Shaft 2	1109934			1	R(Qty)'
28	10383830	Bearing Collar 1	1109935			1	R(Qty)'
29	10386035	Bearing Collar 2	1238199			1	R(Qty)'
30	10300130	Ball Bearing	7922888---	6201LLU/LP03QT		2	R(Qty)'
31	10427991	Nut	P332000006	M10	JIS	2	R(Qty)'
32	10001520	Spring Washer	P336050007	10	JIS	2	R(Qty)'
33	10383832	Shim 1	1109937			2	R(Qty)'
34	10578740	Shim 2	1109936 A			2	R(Qty)'
35	10301149	Plate (for Spring)	1230256--B			1	R(Qty)'
36	10324226	Socket Set Screw	P330570035	M10X30(Dog-end)	JIS	1	R(Qty)'
37	10329309	Socket Set Screw	P330550025	M6X8(Flat Type)	JIS	1	R(Qty)'
38	10001840	Cam Lever	1230257 C			1	R(Qty)'

Unit No. 28
Saw Blade Guide(1)

Index	Code	Parts Name	Drawing No.	Type	Maker	Q'ty	Note
39	10380430	Parallel Pin	P337020155	B-6X50	JIS	1	R(Qty)'
40	10322120	Socket Set Screw	P330590018	M6X8(Dimple Type)	JIS	1	R(Qty)'
41	10583617	Reamer Bolt M12	1230243 B	(M12X50)		1	R(Qty)'
42	10328337	Hex Socket Cap Screw	P330250009	M12X50		1	R(Qty)'
43	10000829	Spring Washer	P336050008	12	JIS	1	R(Qty)'
44	10380421	Washer	1238187			1	R(Qty)'
45	10583614	Guide Bracket L	1238217 D			1	L(Qty)'
46	10378135	Stud Bolt	1238181			1	L(Qty)'
47	10583615	Lever	124469704A	TPH40-M20-120	TOBOX	1	L(Qty)'
48	10322126	Socket Set Screw	P330550049	M10X12(Flat Type)	JIS	2	L(Qty)'
49	10302097	Insert Holder L ASSY	SBS0129---	1238203, 1230252 B, 1230253 B others		1	with Index 50-78
50	10386037	Insert Holder L	1238203			1	L(Qty)'
51	10380439	Slotted Socket Set Screw	P330500006	M8X6(Flat Type)		1	L(Qty)'
52	10328305	Spring Pin	P337030062	6X28AW	JIS	1	L(Qty)'
53	10322120	Socket Set Screw	P330590018	M6X8(Dimple Type)	JIS	2	L(Qty)'
54	10312317	Fixed Insert L	1230252 B			1	L(Qty)'
55	10589206	Hex Socket Cap Screw	P330220003	M6X10		2	L(Qty)'
56	10312329	Movable Insert L	1230253 B			1	L(Qty)'
57	10328304	Spring Pin	P337030055	6X14AW	JIS	1	L(Qty)'

Unit No. 28
Saw Blade Guide(1)

Index	Code	Parts Name	Drawing No.	Type	Maker	Q'ty	Note
58	10312594	Pin	1230290			1	L(Qty)'
59	10418979	Backup Roller Holder	1230254 A			1	L(Qty)'
60	10300129	Deep Groove Ball Bearing	7922885---	6200LLU/LP03QT	NTN	2	L(Qty)'
61	10312852	Roller Pin	0637054			2	L(Qty)'
62	10385735	Sleeve	1230255 A			1	L(Qty)'
63	10330101	Hex Socket Cap Screw	P330230008	M8X30		1	L(Qty)'
64	10383828	Bearing Shaft 1	1109933			1	L(Qty)'
65	10383829	Bearing Shaft 2	1109934			1	L(Qty)'
66	10383830	Bearing Collar 1	1109935			1	L(Qty)'
67	10386035	Bearing Collar 2	1238199			1	L(Qty)'
68	10300130	Ball Bearing	7922888---	6201LLU/LP03QT		2	L(Qty)'
69	10427991	Nut	P332000006	M10	JIS	2	L(Qty)'
70	10001520	Spring Washer	P336050007	10	JIS	2	L(Qty)'
71	10383832	Shim 1	1109937			2	L(Qty)'
72	10578740	Shim 2	1109936 A			2	L(Qty)'
73	10301149	Plate (for Spring)	1230256--B			1	L(Qty)'
74	10324226	Socket Set Screw	P330570035	M10X30(Dog-end)	JIS	1	L(Qty)'
75	10322120	Socket Set Screw	P330590018	M6X8(Dimple Type)	JIS	1	L(Qty)'
76	10001840	Cam Lever	1230257 C			1	L(Qty)'

Unit No. 28

Saw Blade Guide(1)

Index	Code	Parts Name	Drawing No.	Type	Maker	Q'ty	Note
77	10380430	Parallel Pin	P337020155	B-6X50	JIS	1	L(Qty)'
78	10322120	Socket Set Screw	P330590018	M6X8(Dimple Type)	JIS	1	L(Qty)'
79	10583617	Reamer Bolt M12	1230243 B	(M12X50)		1	L(Qty)'
80	10328337	Hex Socket Cap Screw	P330250009	M12X50		1	L(Qty)'
81	10000829	Spring Washer	P336050008	12	JIS	1	L(Qty)'
82	10380421	Washer	1238187			1	L(Qty)'
83	10419326	Stopper	1238226	FB19X4.5		1	
84	10342325	Hex Socket Cap Screw	P330230004	M8X15		2	

Unit No. 29
Saw Blade Guide(2)-1/2 <HA400W>

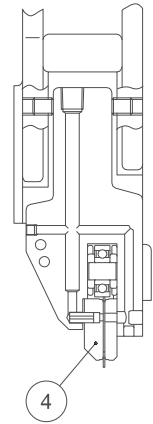

SECTION A-A

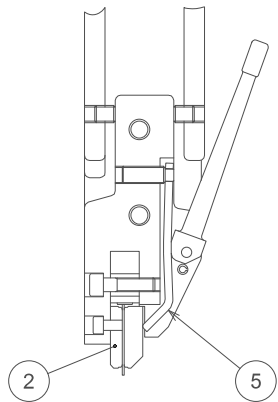

SECTION B-B

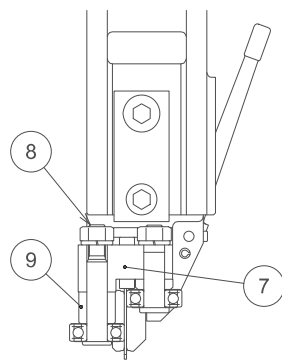

DETAIL C

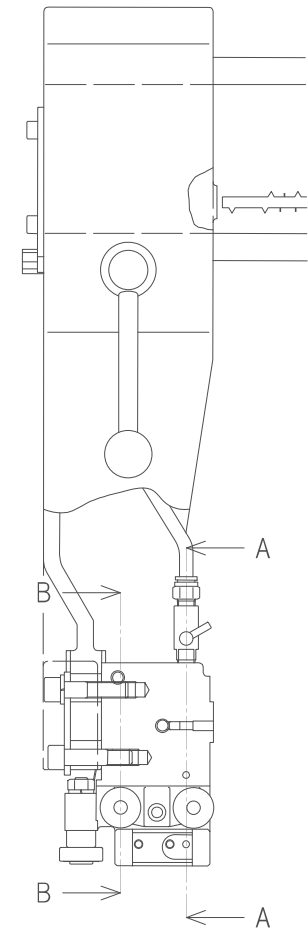
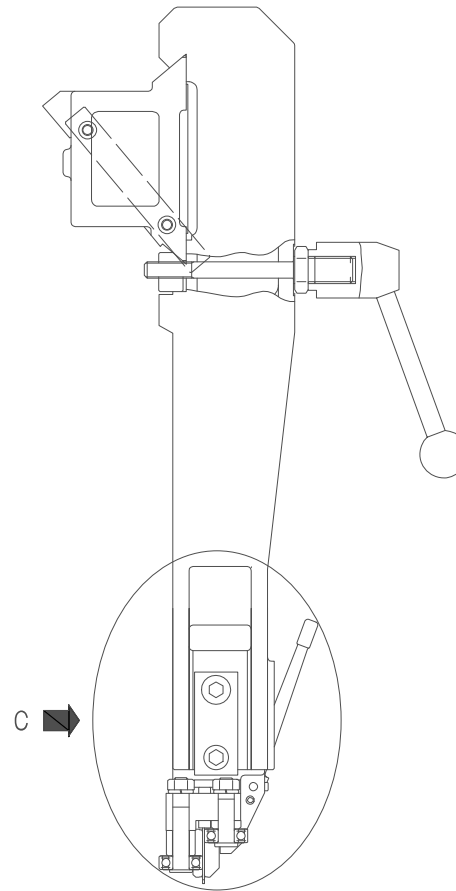

1230642B
(1278784--A)

Unit No. 29
Saw Blade Guide(2)-2/2 <HA400W>

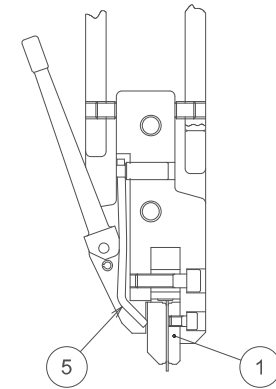
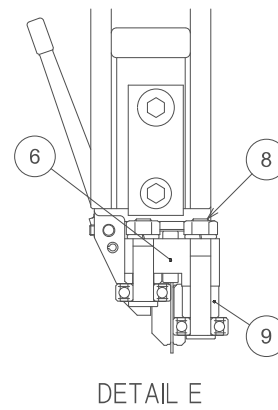
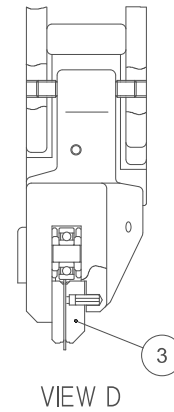
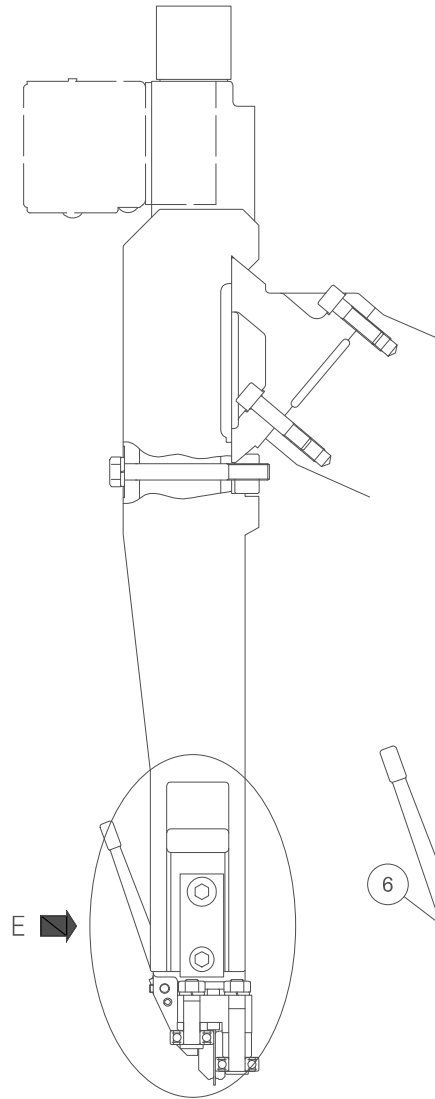
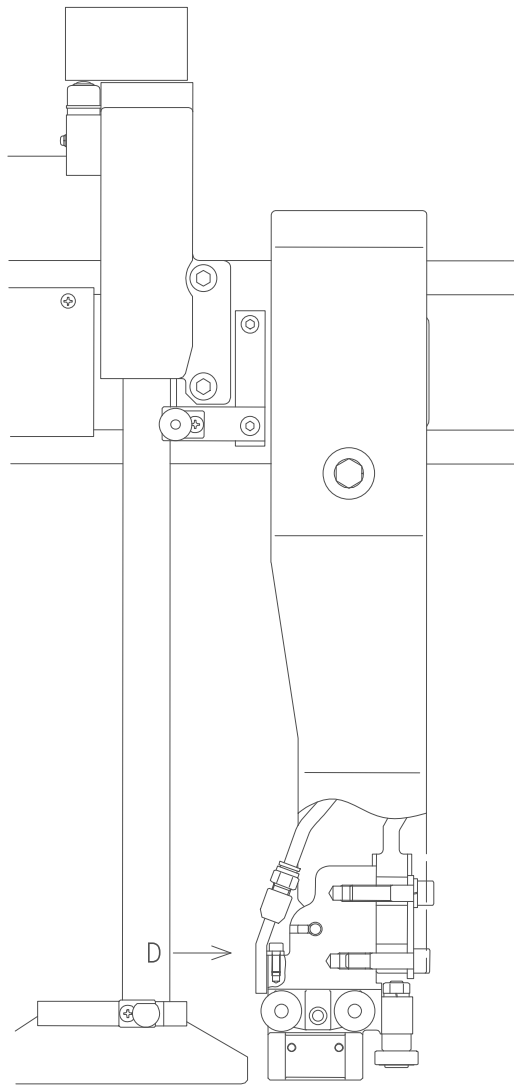

1230642B
(1278784--A)

Unit No. 29

Saw Blade Guide(2)

Index	Code	Parts Name	Drawing No.	Type	Maker	Q'ty	Note
1	10381240	Fixed Insert R	1231740			1	
2	10381245	Fixed Insert L	1231743			1	
3	10381242	Movable Insert R	1231741			1	
4	10381247	Movable Insert L	1231742			1	
5	10327708	Plate (for Spring)	1231732			2	
6	10419754	Insert Holder R	1231747			1	
7	10419757	Insert Holder L	1231748			1	
8	10419755	Bearing Shaft 2	1238954			2	
9	10419756	Bearing Collar 2	1238955			2	

Unit No. 30
Saw Blade Guide(3) <EU Specification Machine>

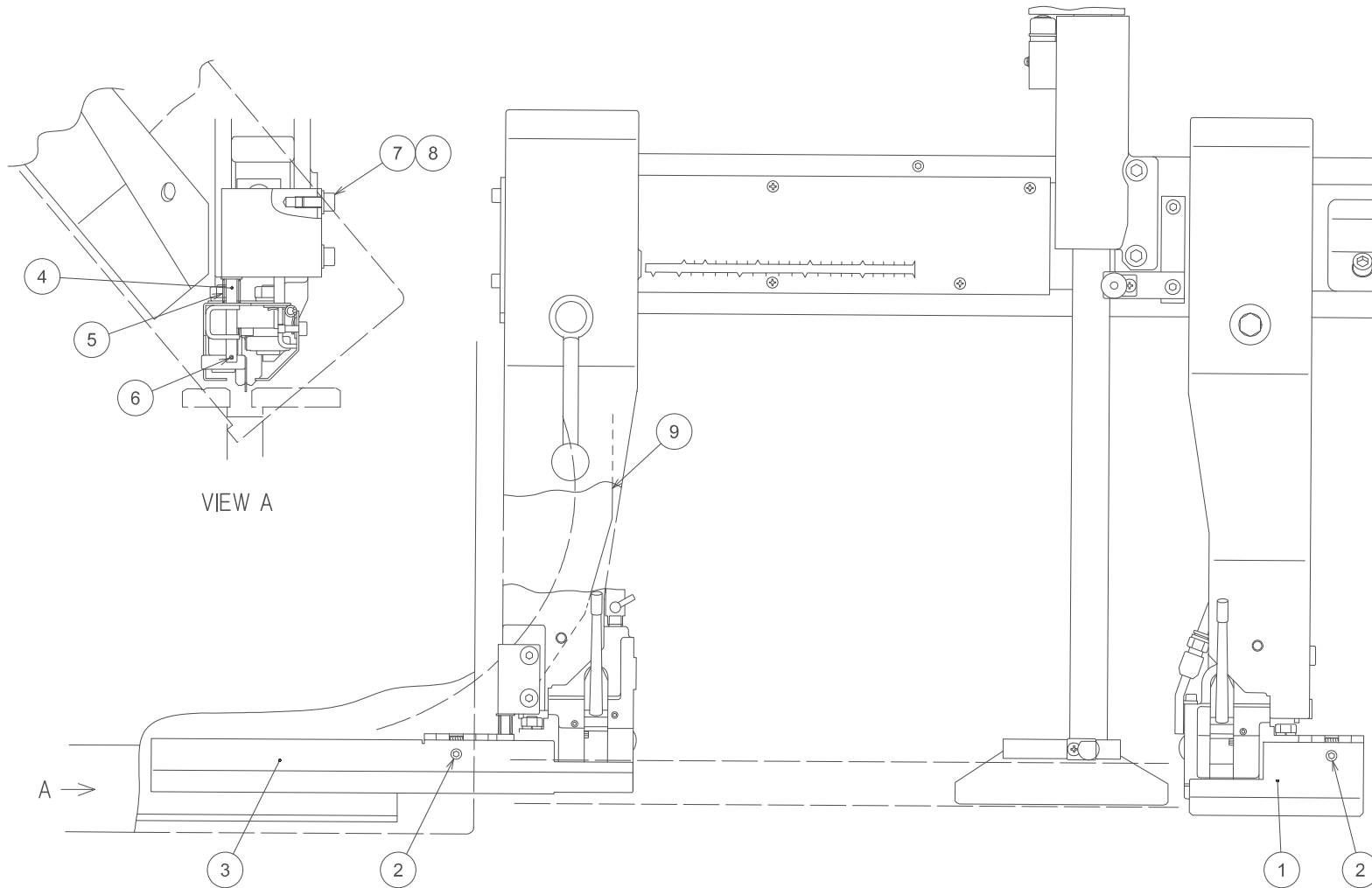

1230537F

Unit No. 30

Saw Blade Guide(3)

Index	Code	Parts Name	Drawing No.	Type	Maker	Q'ty	Note
1	10301256	Blade Cover R	1440914 D			1	
2	10322615	Hex Socket Cap Screw	1200256 A	M6X16		2	
3	10301257	Blade Cover L	1440915 F			1	
4	10301258	Spring Guide	1440916 D			1	
5	10315205	Feedback Spring	0654330 A			1	
6	10331237	Spring Pin	P337030013	3X14AW	JIS	1	
7	10343103	Hex Socket Cap Screw	P330230005	M8X16	JIS	2	
8	10301282	Washer	P336000041	8(Small Round)	JIS	3	
9	10583609	Driven Support Cover	1230658 B			1	

Unit No. 31
 Saw Blade Guide(4)-1/2 <Quick Approach>

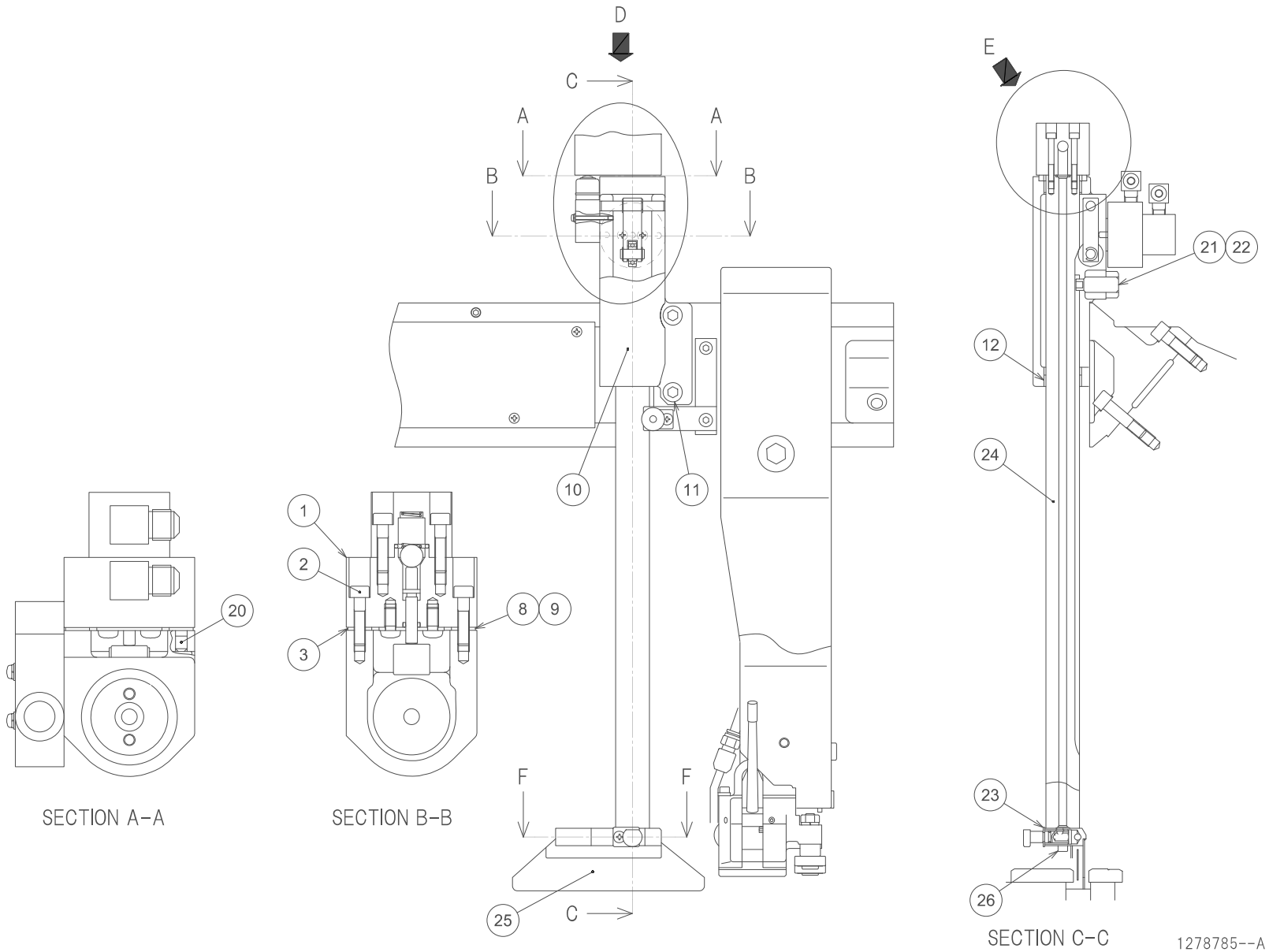

1278785--A

Unit No. 31
Saw Blade Guide(4)-2/2 <Quick Approach>

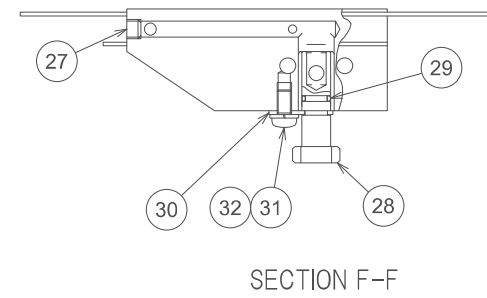
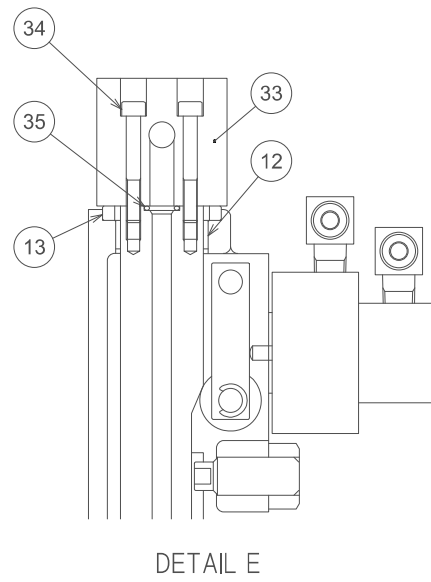
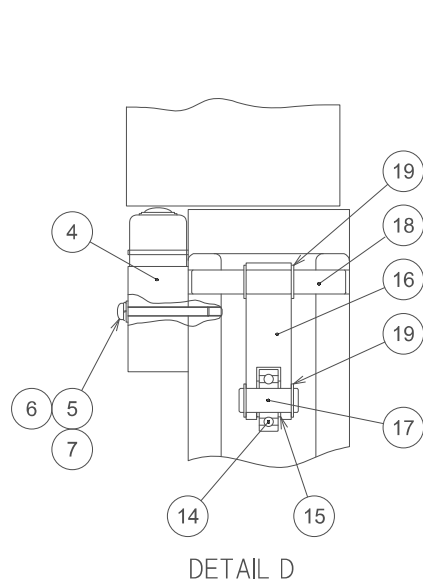

1278785--A

Unit No. 31
Saw Blade Guide(4)

Index	Code	Parts Name	Drawing No.	Type	Maker	Q'ty	Note
1	10301276	Quick Approach Valve	7922619		YUATSU SEIKO	1	
2	10324622	Hex Socket Cap Screw	P330220011	M6X25		2	
3	10321922	Washer	P336000005	6(Normal)	JIS	2	
4	10204724	Limit Switch	P828012022	ZE-N-2	OMRON	1	
5	10328314	Pan Head Screw	P334100027	M4X35	JIS	2	
6	10318527	Spring Washer	P336050003	4	JIS	2	
7	10337110	Washer	P336000003	4(Small Round)	JIS	2	
8	10328161	Shim 0.1T	1230287			6	
9	10328162	Shim 0.5T	1230288			6	
10	10419327	Approach Bar Guide	1230278 E			1	
11	10328331	Hex Socket Cap Screw	P330250007	M12X40		2	
12	10581661	Plain Bearing	P407003179	DUB3512	DAIDO METAL	2	
13	10328166	Urethane Cushion	1230289			1	
14	10380456	Deep Groove Ball Bearing	P400010533	6000ZZ	NSK & others	1	
15	10312901	Locating Snap Ring	P406108034	STW-11	OCHIAI	2	
16	10300540	Roller Lever	RB00468--A			1	
17	10301125	Roller Pin	RB01915--A			1	
18	10301454	Roller Lever Pin	RB01916--A			1	
19	10380457	Locating Snap Ring	P406100005	E-7	JIS	4	

Unit No. 31
Saw Blade Guide(4)

Index	Code	Parts Name	Drawing No.	Type	Maker	Q'ty	Note
20	10322120	Socket Set Screw	P330590018	M6X8(Dimple Type)	JIS	1	
21	10328239	Guide Bolt	1230291			1	
22	10421756	Nut	P332000009	M16	JIS	1	
23	10328163	Shim	1230294			1	
24	10380450	Approach Bar	1238182 A			1	
25	10301455	Filler	RB01920--A			1	
26	10324622	Hex Socket Cap Screw	P330220011	M6X25		2	
27	10378145	Socket Set Screw	P330550131	M8X6(Flat Type)	JIS	1	
28	10378153	Cock	1238198			1	
29	10314519	O Ring	P590000007	P9		1	
30	10312046	Stopper Plate	1230190			1	
31	10322226	Pan Head Screw	P334100055	M6X12	JIS	1	
32	10310351	Spring Washer	P336050005	6	JIS	1	
33	10380452	LS Dog	1238192			1	
34	10310362	Hex Socket Cap Screw	P330220015	M6X45		2	
35	10206605	O Ring	P590000010	P11		1	

Unit No. 32
Saw Blade Guide(5) <HA400W>

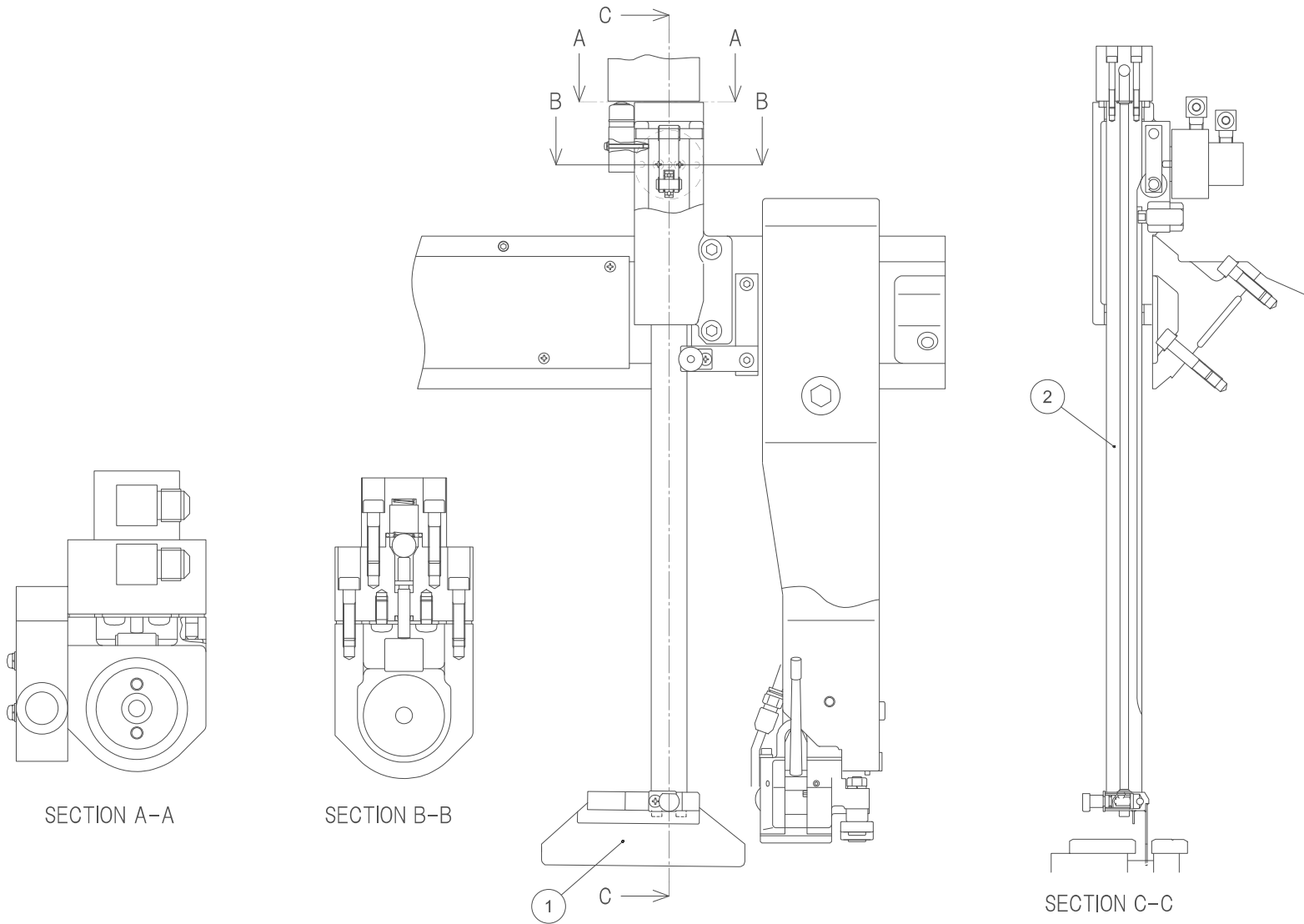

1278785--A

Unit No. 32

Saw Blade Guide(5)

Index	Code	Parts Name	Drawing No.	Type	Maker	Q'ty	Note
1	10301506	Filler	RB02366--A			1	
2	10379531	Approach Bar	1286528			1	

Unit No. 33
Saw Blade Guide(6) <Stopper>

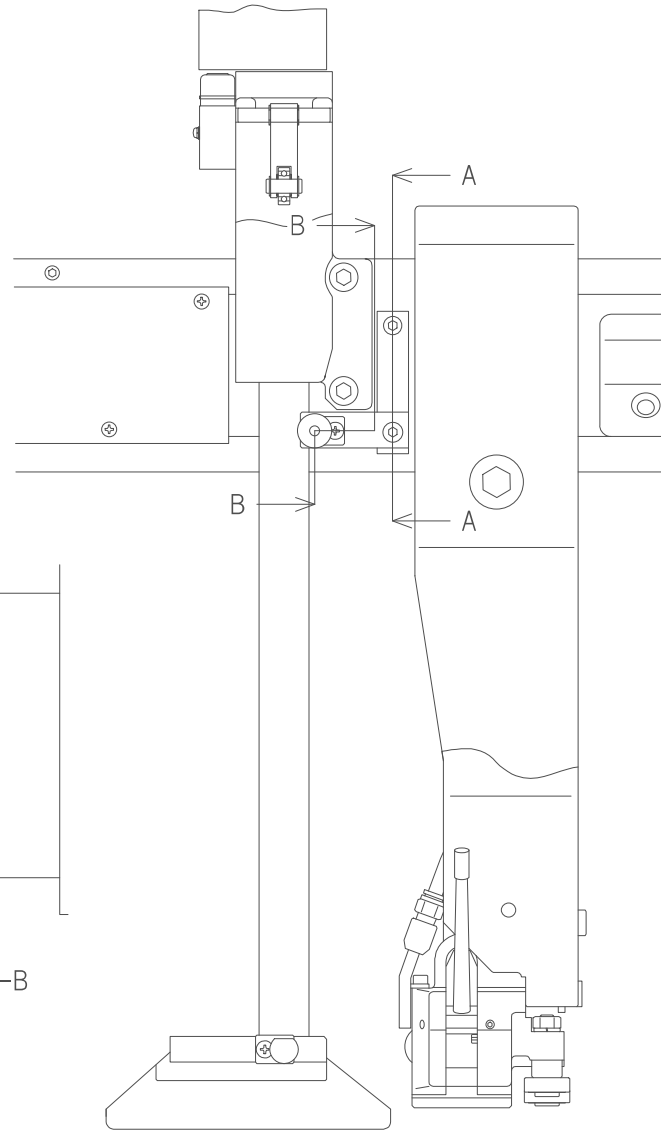
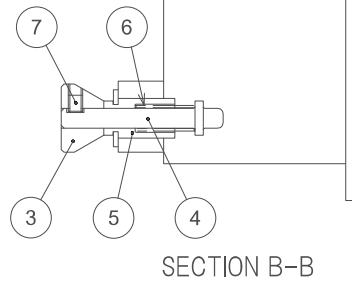
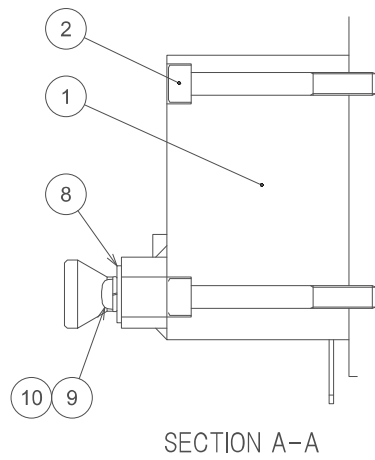

1278786---
(1278785--A)

Unit No. 33

Saw Blade Guide(6)

Index	Code	Parts Name	Drawing No.	Type	Maker	Q'ty	Note
1	10380463	Block	1238211 B			1	
2	10443025	Hex Socket Cap Screw	P330230016	M8X70		2	
3	10380460	Knob	1238189			1	
4	10380461	Shaft	1238190 A			1	
5	10380462	Holder	1238191 A			1	
6	10301278	Coil Spring	P320003001	AP090-023-0.8	SHOWA HATSUJO	1	
7	10329312	Socket Set Screw	P330550016	M5X6(Flat Type)	JIS	1	
8	10312046	Stopper Plate	1230190			1	
9	10322226	Pan Head Screw	P334100055	M6X12	JIS	1	
10	10310351	Spring Washer	P336050005	6	JIS	1	

Unit No. 34
Hydraulic(1)

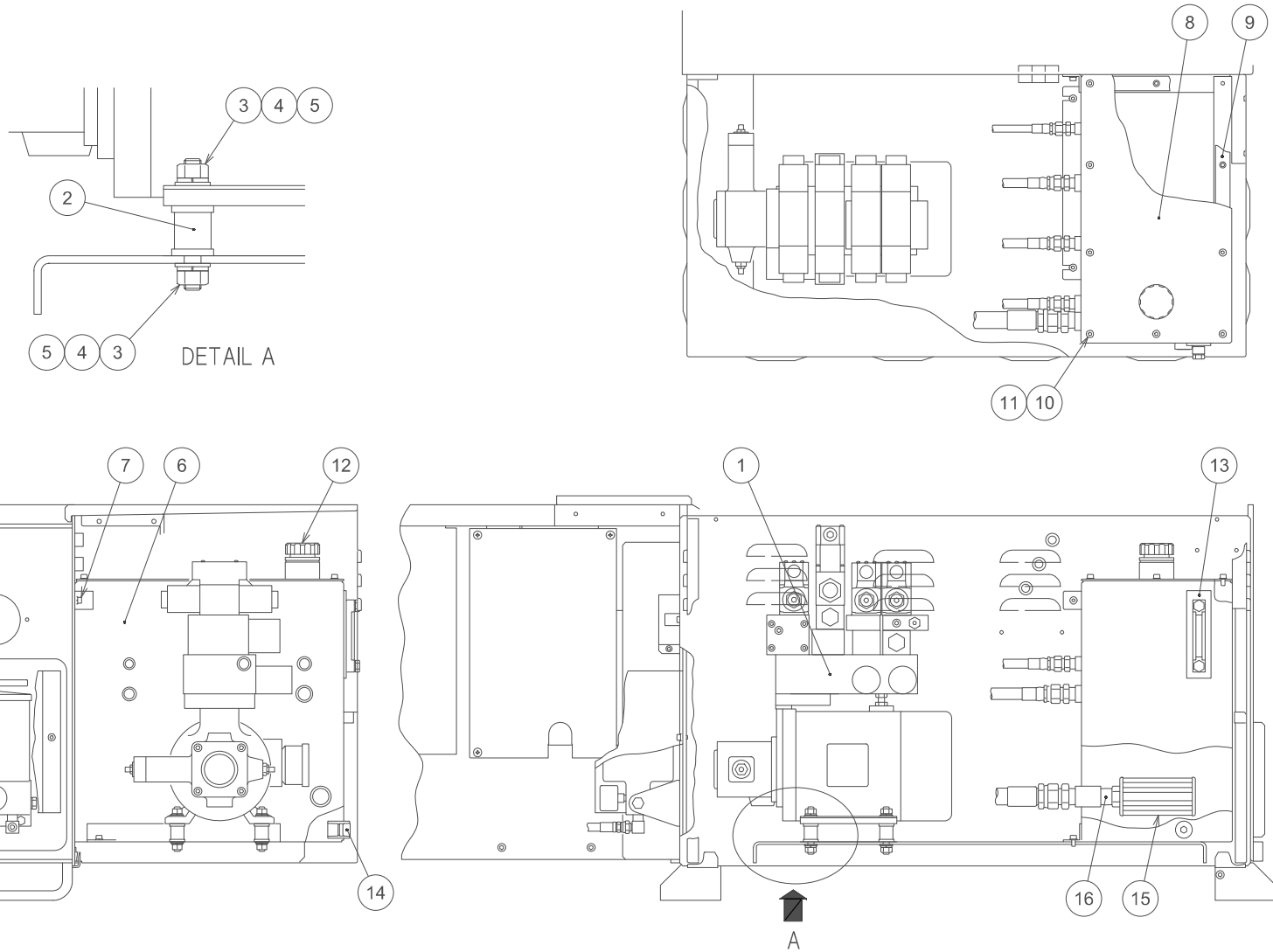

1278890--B
(1278790--B)

Unit No. 34
Hydraulic(1)

Index	Code	Parts Name	Drawing No.	Type	Maker	Q'ty	Note
1	10301460	Hydraulic Unit	RB01941--A			1	
2	10583644	Vibration Isolator	124469705B			4	
3	10325021	Washer	P336000007	10(Normal)	JIS	8	
4	10427991	Nut	P332000006	M10	JIS	8	
5	10001520	Spring Washer	P336050007	10	JIS	8	
6	10419330	Hydraulic Tank	1440411			1	
7	10323201	Hex Socket Cap Screw	P330220004	M6X12	JIS	4	
8	10301465	Tank Cover	RB01953--A			1	
9	10419332	Rubber Sheet	1440413			1	
10	10323201	Hex Socket Cap Screw	P330220004	M6X12	JIS	10	
11	10310351	Spring Washer	P336050005	6	JIS	10	
12	10583645	Oil Cap	124469706B	YS-70I(L)SFN-57-1-1/2	ELESA	1	
13	10580109	Level Gauge	P600108033	KLA-100SN-A (Float : Red)	KYOWA	1	
14	10301299	Plug for Piping	P580208004	GM-1/2	GOSHO Works	1	
15	10583647	Hydraulic Filter	124469708B	SFT-06-150W	YU-XING	1	
16	10329330	Barrel Nipple	P580040005	3/4		1	

Unit No. 35
Hydraulic(2) <Hydraulic Unit>

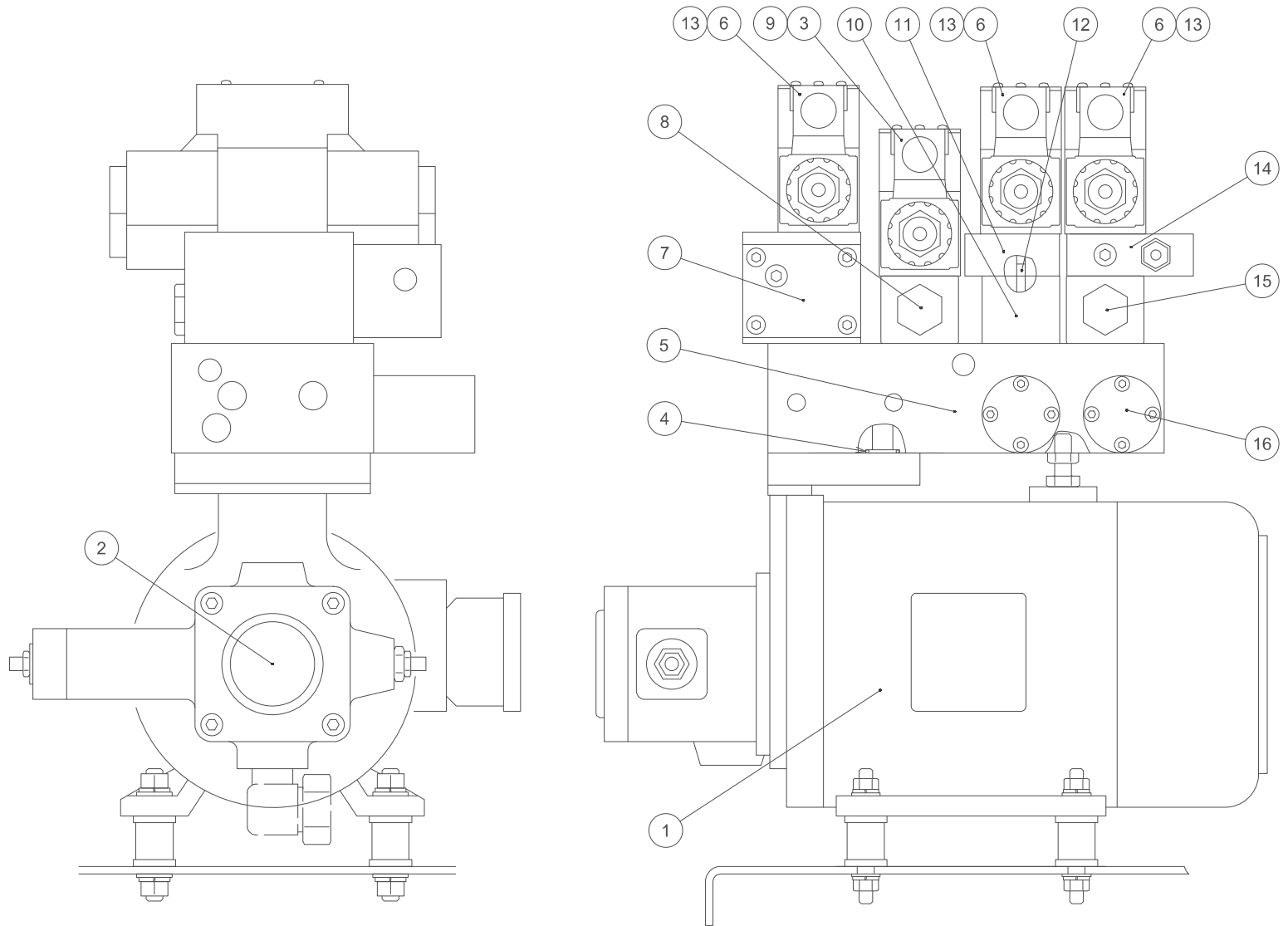

RB01941#1-
(1278790---)

Unit No. 35
Hydraulic(2)

Index	Code	Parts Name	Drawing No.	Type	Maker	Q'ty	Note
1	10301461	Pump Motor	RB0195101-	1.5kW§1440rpm		1	
2	10301462	Pump	RB0195102-	VD1-30F-A3	ASADA	1	
3	10561516	Hex Socket Cap Screw	P330210023	M5X85	MOURI	4	
4	10001117	O Ring	P590000020	P22		1	
5	10300559	Manifold	RB0050805B			1	
6	10300565	Solenoid Valve	RB0050812-	D4-02-3C4-D2	ASADA	3	
7	10300566	Filter	RB0050813-	1309.3-00		1	
8	10300567	Modular Valve	RB0050814-	MPW-02A		1	
9	10300565	Solenoid Valve	RB0050812-	D4-02-3C4-D2	ASADA	1	
10	10300569	Modular Valve	RB0050816-	MCP-02-A		1	
11	10300562	Middle Plate	RB0050808A	80149		1	
12	10301463	Orifice	RB0195115-	1309.5		2	
13	10300134	Hex Socket Cap Screw	P330210020	M5X110	MOURI	12	
14	10301464	Sub Plate	RB0195118-	1309.8		1	
15	10300568	Modular Valve	RB0050815-	MPA-02A		1	
16	10300570	Differential Pressure Switch	RB0050817-	1309-2		2	

Unit No. 36

Hydraulic(3) <Power Source Voltage:230/460V>

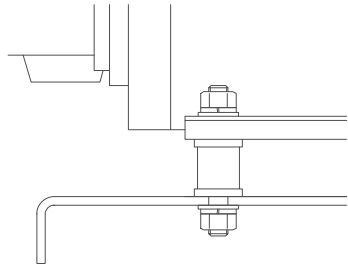

DETAIL A

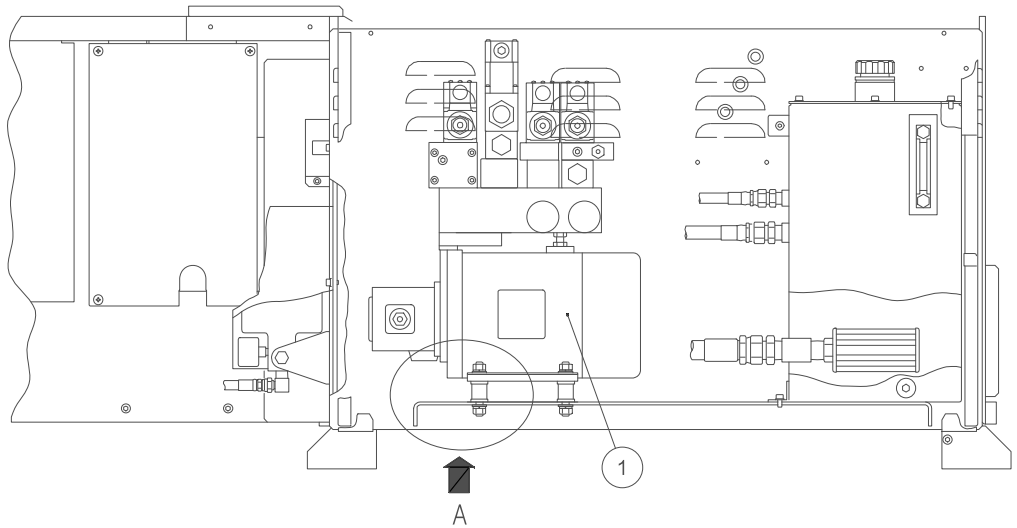
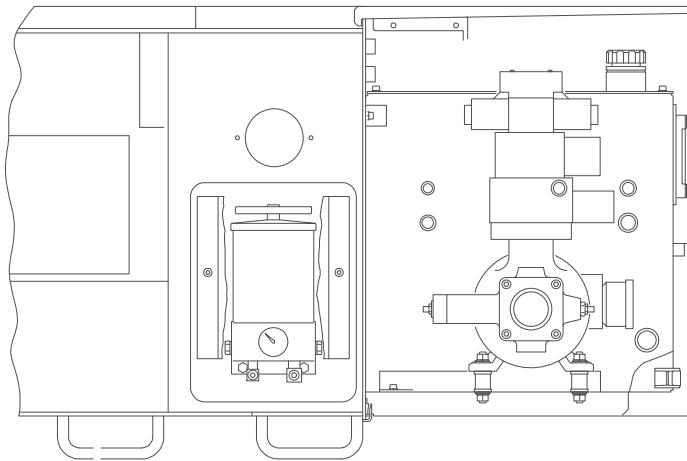
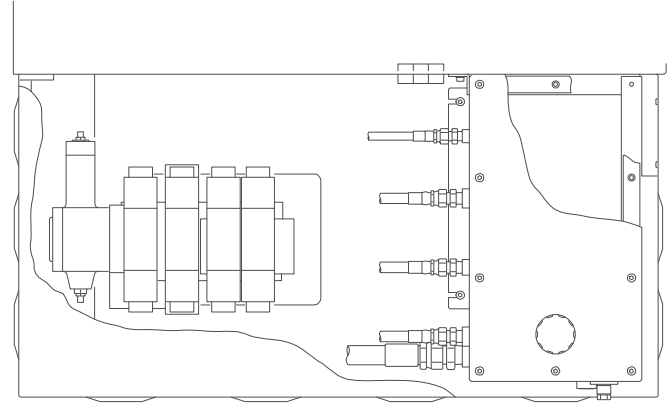

RB02427---
(1278790--B)

Unit No. 36
Hydraulic(3)

Index	Code	Parts Name	Drawing No.	Type	Maker	Q'ty	Note
1	10301516	Pump Motor US	RB02427---	1.5kW 230/460V(60Hz)		1	

Unit No. 37

Hydraulic(4) <Power Source Voltage:400V>

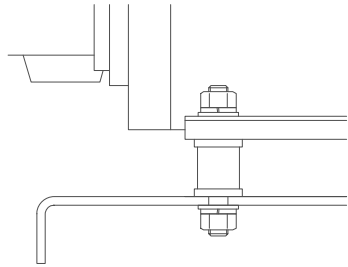

DETAIL A

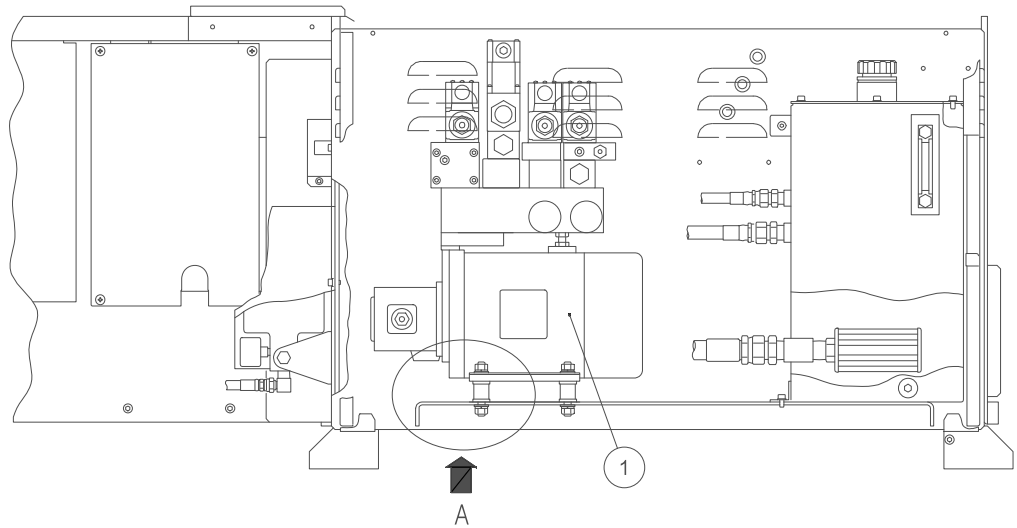
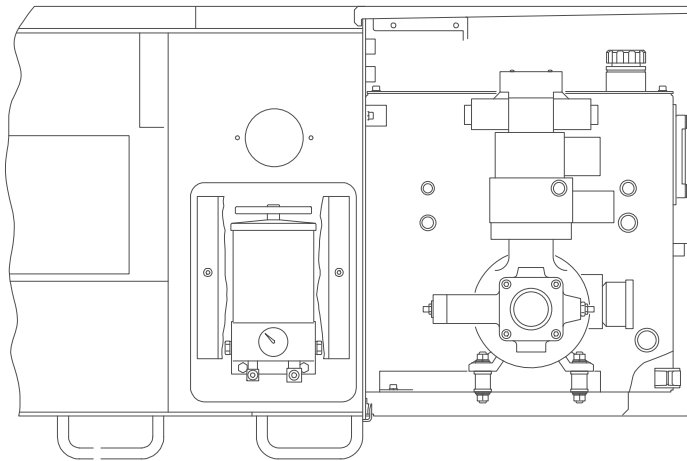
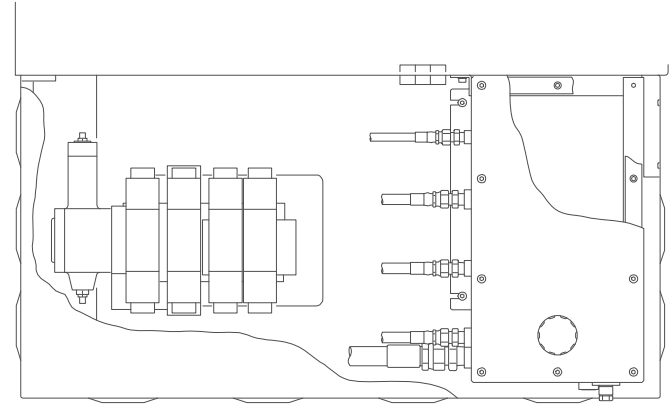

RB02477---
(1278790--B)

Unit No. 37
Hydraulic(4)

Index	Code	Parts Name	Drawing No.	Type	Maker	Q'ty	Note
1	10301524	Pump Motor 400V	RB02477---	1.5kW 400V(50Hz)		1	

Unit No. 38
 Hydraulic(5)-1/2 <Piping>

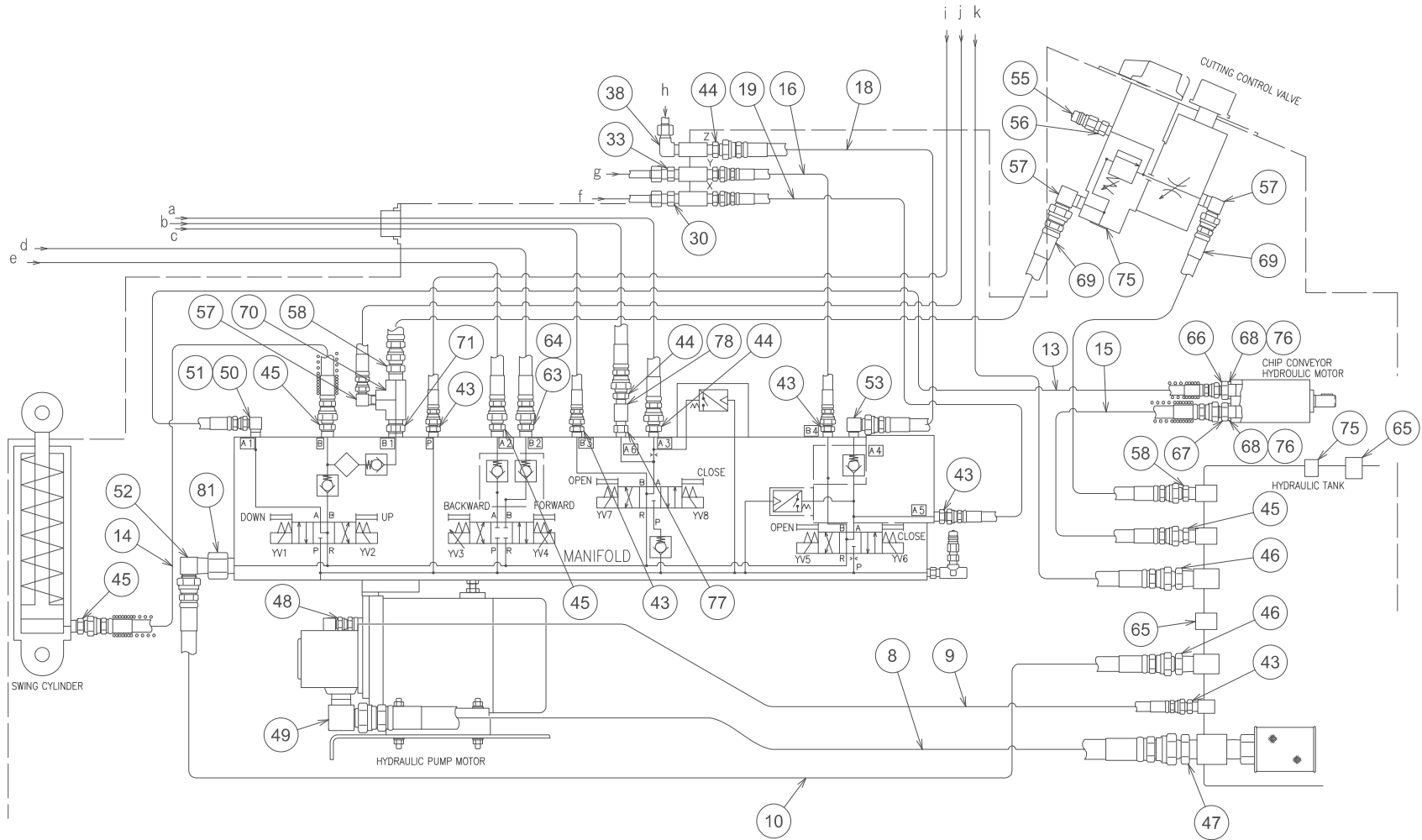

1278891--B

Unit No. 38
 Hydraulic(5)-2/2 <Piping>

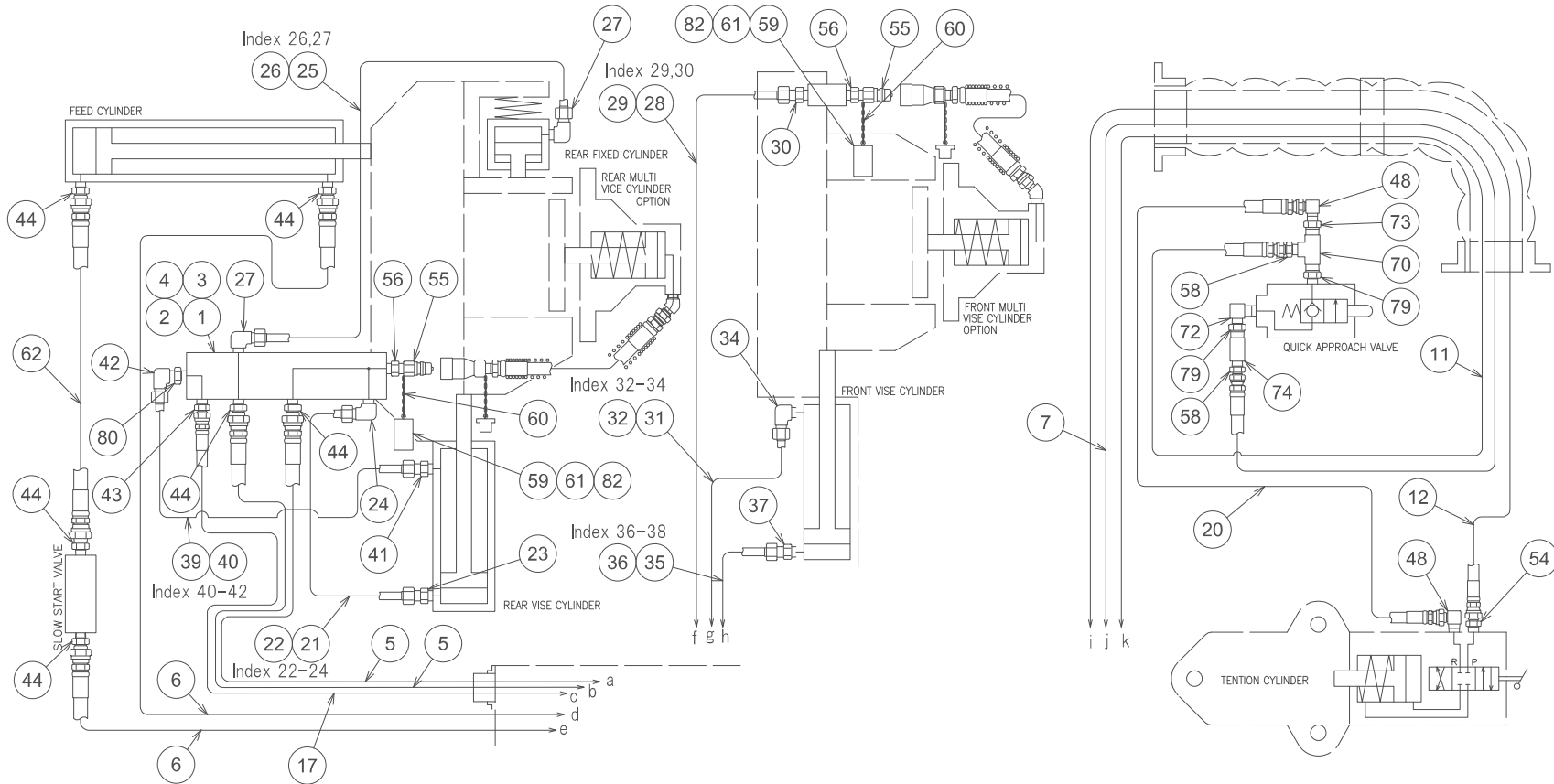

1278891--B

Unit No. 38
Hydraulic(5)

Index	Code	Parts Name	Drawing No.	Type	Maker	Q'ty	Note
1	10378668	Manifold Block A	1238679 B			1	
2	10326113	Hex Socket Cap Screw	P330220016	M6X50		2	
3	10321922	Washer	P336000005	6(Normal)	JIS	2	
4	10310351	Spring Washer	P336050005	6	JIS	2	
5	10583648	Hydraulic Hose 1	1230714 B			2	
6	10378172	Hydraulic Hose 2	1238256			2	
7	10380512	Hydraulic Hose 3	1238257 A			1	
8	10301466	Hydraulic Hose 4	RB01965--B			1	
9	10301467	Hydraulic Hose 5	RB01966--A			1	
10	10378206	Hydraulic Hose 6	1238260			1	
11	10380513	Hydraulic Hose 7	1238261 A			1	
12	10378207	Hydraulic Hose 9	1238263 A			1	
13	10378208	Hydraulic Hose 10	1238264 A			1	
14	10378209	Hydraulic Hose 11	1238265 A			1	
15	10378210	Hydraulic Hose 12	1238266 A			1	
16	10419522	Hydraulic Hose 13	1244710			1	
17	10583650	Hydraulic Hose 14	1230715 B			1	
18	10419523	Hydraulic Hose 15	1244711			1	
19	10419524	Hydraulic Hose 16	1244712			1	

Unit No. 38
Hydraulic(5)

Index	Code	Parts Name	Drawing No.	Type	Maker	Q'ty	Note
20	10419334	Hydraulic Hose 17	1238271 B			1	
21	10301474	Pipe	RB02005---			1	with Index 22-24
22	10301475	Pipe	RB0200501-			1	
23	10589417	Bite Type Pipe Fitting	P585032029	KCT10-020E (Male Connector)	IHARA Science	1	
24	10583658	Bite Type Pipe Fitting	P585062056	KLN10-020E	IHARA Science	1	
25	10301476	Pipe	RB02006---			1	with Index 26,27
26	10301477	Pipe	RB0200601-			1	
27	10583658	Bite Type Pipe Fitting	P585062056	KLN10-020E	IHARA Science	2	
28	10301478	Pipe	RB02007--A			1	with Index 29,30
29	10301479	Pipe	RB0200701A			1	
30	10589417	Bite Type Pipe Fitting	P585032029	KCT10-020E (Male Connector)	IHARA Science	2	
31	10301480	Pipe	RB02008---			1	with Index 32-34
32	10301481	Pipe	RB0200801-			1	
33	10589417	Bite Type Pipe Fitting	P585032029	KCT10-020E (Male Connector)	IHARA Science	1	
34	10583658	Bite Type Pipe Fitting	P585062056	KLN10-020E	IHARA Science	1	
35	10301482	Pipe	RB02009--A			1	with Index 36-38
36	10301483	Pipe	RB0200901A			1	
37	10589417	Bite Type Pipe Fitting	P585032029	KCT10-020E (Male Connector)	IHARA Science	1	
38	10583658	Bite Type Pipe Fitting	P585062056	KLN10-020E	IHARA Science	1	

Unit No. 38
Hydraulic(5)

Index	Code	Parts Name	Drawing No.	Type	Maker	Q'ty	Note
39	10301484	Pipe	RB02011---			1	with Index 40-42
40	10301485	Pipe	RB0201101-			1	
41	10589417	Bite Type Pipe Fitting	P585032029	KCT10-020E (Male Connector)	IHARA Science	1	
42	10583658	Bite Type Pipe Fitting	P585062056	KLN10-020E	IHARA Science	1	
43	10300596	Male-Male Adapter	RB0054011A	PT1/4-PF1/4		8	
44	10300597	Male-Male Adapter	RB0054013B	PT1/4-PF3/8		9	
45	10300598	Male-Male Adapter	RB0054014A	PT3/8-PF3/8		4	
46	10300601	Male-Male Adapter	RB0054017A	PT1/2-PF1/2		2	
47	10300602	Male-Male Adapter	RB0054018A	PT3/4-PF3/4		1	
48	10300603	Elbow	RB0054021A	PT1/4-PF1/4		3	
49	10301469	Elbow	RB0198901-	PT3/4-PF3/4		1	
50	10300604	Elbow	RB0054022A	PT1/4-PF1/4		1	
51	10300609	Bolt for Adapter	RB0054031-			1	
52	10300606	Elbow	RB0054025A	PT1/2-PF1/2		1	
53	10301126	Elbow	RB0198903-	PT1/4-PF3/8		1	
54	10300624	Check Nipple	RB00541--A			1	
55	10375464	Quick Connect Joint	P589026080	2P-BSBM	NITTO KOHKI	3	
56	10329329	Nipple	P580020002	1/4	JIS	3	
57	10301472	Elbow	RB0198908-	PT3/8-PF1/2		3	

Unit No. 38
Hydraulic(5)

Index	Code	Parts Name	Drawing No.	Type	Maker	Q'ty	Note
58	10301470	Male-Male Adapter	RB0198904-	PT3/8-PF1/2		4	
59	10300626	Rubber Cap	RB00543---			2	
60	10300613	Chain	RB0054035-	L=150		2	
61	10329430	Split Pin	P337000034	3.2X22(Mild Steel)	JIS	2	
62	10378183	Hose A	1238595			1	
63	10300600	Male-Male Adapter	RB0054016A	PT3/8-PF3/8		1	
64	10301468	Adapter	RB01987--A			1	
65	10380545	Plug	P580208013	PT-3/8		2	
66	10300610	Coupling	RB0054032A	G3/8-G1/4		1	
67	10301471	Coupling	RB0198905-	G3/8-G3/8		1	
68	10300611	Copper Washer	RB0054033-			2	
69	10419335	Hydraulic Hose	1427744	1/2X4000		2	
70	10589413	Tee	P580100003	3/8	JIS	2	
71	10378201	Nipple	P580020003	3/8	JIS	1	
72	10301473	Elbow	RB0198909-			1	
73	10589714	Bush for Piping	P580010002	3/8X1/4	JIS	1	
74	10301297	Socket for Piping	P580000003	3/8	JIS	1	
75	10300171	Plug for Piping	P580208021	PT-1/4		2	
76	10300615	O Ring	RB0054038-	14X1.8		2	

Unit No. 38
Hydraulic(5)

Index	Code	Parts Name	Drawing No.	Type	Maker	Q'ty	Note
77	10329329	Nipple	P580020002	1/4	JIS	1	
78	10329217	Socket for Piping	P580000002	1/4	JIS	1	
79	10003931	Nipple	P580020010	3/8X1/4	JIS	2	
80	10301298	Socket for Piping	P580000053	SXS-82820	KOYO	1	
81	10300167	Socket for Piping	P580002018	SSS04-040J	IHARA Science	1	
82	10375463	Cable Band	P381058035	SKB-2M	KITAGAWA	2	

Unit No. 39
Hydraulic(6) <Pressure Control Valve>

1 Index 2-24

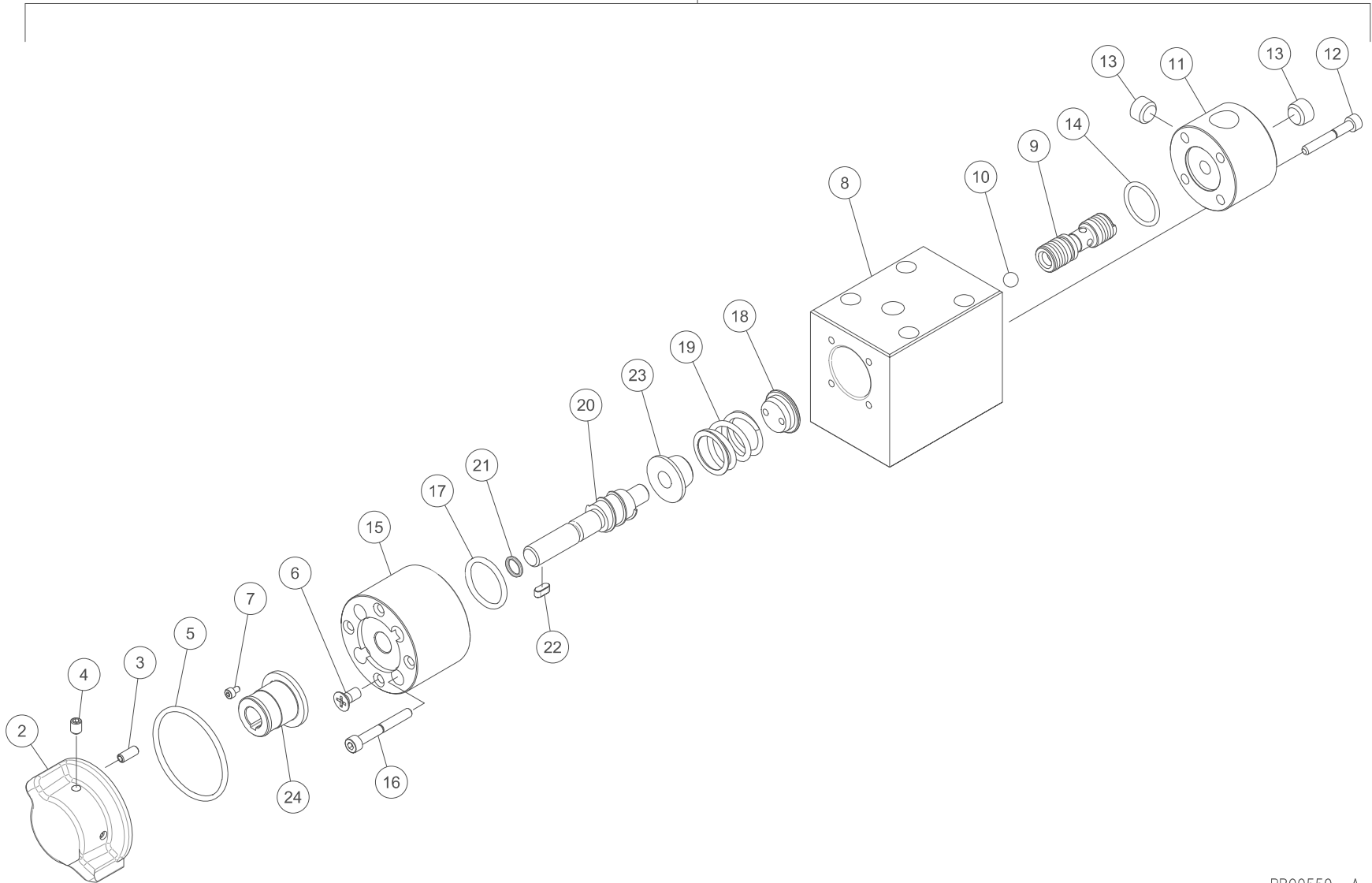

RB00550--A

Unit No. 39
Hydraulic(6)

Index	Code	Parts Name	Drawing No.	Type	Maker	Q'ty	Note
1	10302098	Vise Pressure Control Valve ASSY	SBS0130---	RB00551---, RB00552---, RB00553--- others		1	with Index 2-24
2	10300629	Dial	RB00551---			1	
3	10329648	Spring Pin	P337030037	5X12AW	JIS	1	
4	10322120	Socket Set Screw	P330590018	M6X8(Dimple Type)	JIS	2	
5	10332957	O Ring	P590010006	G50		1	
6	10330114	Flat Head Screw	P334110026	M6X12	JIS	4	
7	10372064	Hex Socket Cap Screw	P330200037	M3X5	JIS	2	
8	10300630	Body	RB00552---			1	
9	10300631	Spool	RB00553---			1	
10	10315427	Steel Ball (for Bearing)	P406000005	5/16	JIS	1	
11	10300632	Head Cap	RB00554---			1	
12	10329636	Hex Socket Cap Screw	P330210012	M5X35		4	
13	10300171	Plug for Piping	P580208021	PT-1/4		2	
14	10001117	O Ring	P590000020	P22		1	
15	10300633	End Cap	RB00555--A			1	
16	10329637	Hex Socket Cap Screw	P330210013	M5X40		4	
17	10316424	O Ring	P590010001	G25		1	
18	10300634	Spring Washer	RB00556---			1	
19	10300635	Spring	RB00557---			1	

Unit No. 39
Hydraulic(6)

Index	Code	Parts Name	Drawing No.	Type	Maker	Q'ty	Note
20	10300636	Adjust Screw	RB00558---			1	
21	10314519	O Ring	P590000007	P9		1	
22	10380544	Parallel Key	P436000079	4X4X10(Double Ended Round)	JIS	1	
23	10300637	Spring Washer	RB00559---			1	
24	10300639	Collar	RB00561---			1	

Unit No. 40
 Hydraulic(7) <Flow Control Valve>

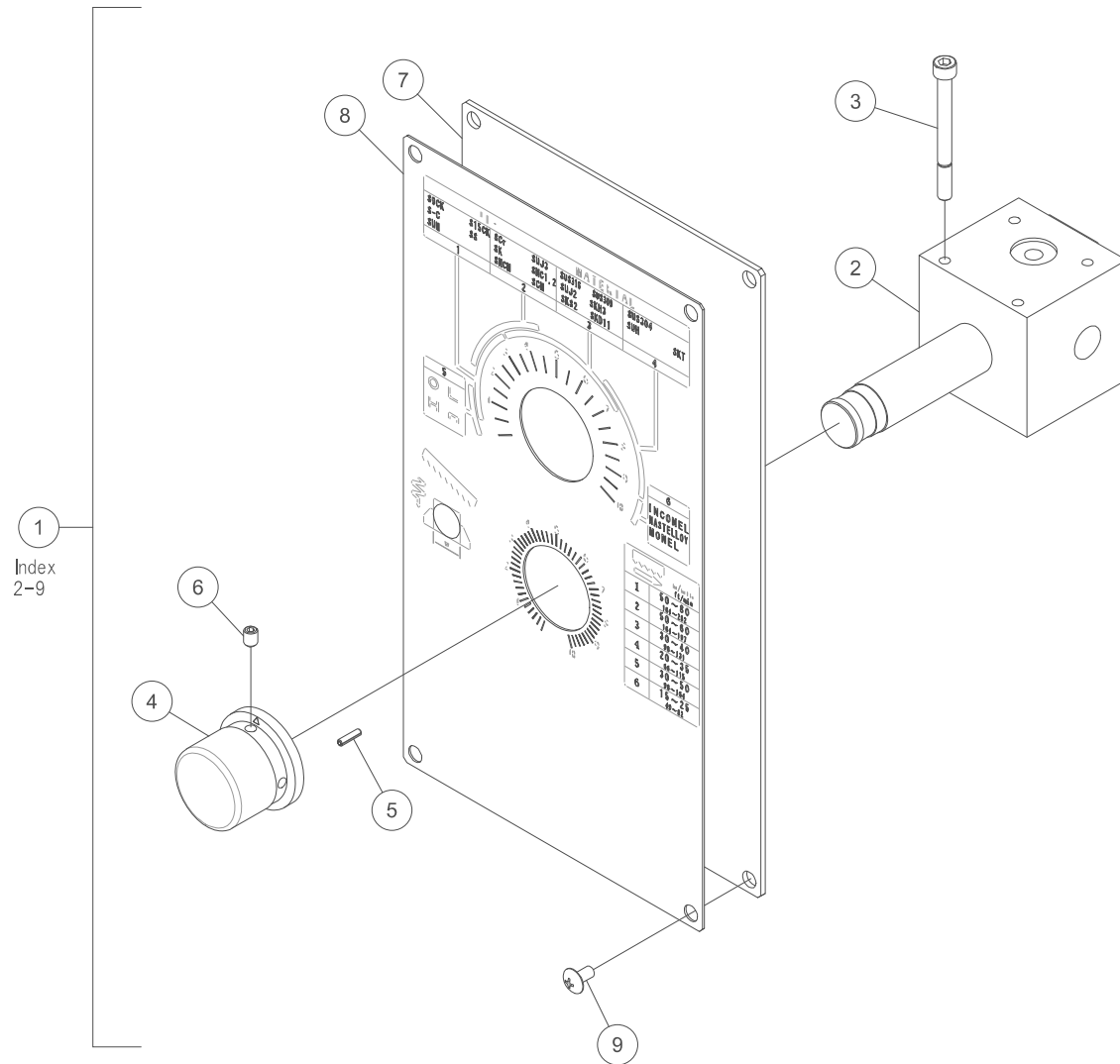

Unit No. 40
Hydraulic(7)

Index	Code	Parts Name	Drawing No.	Type	Maker	Q'ty	Note
1	10302099	Flow Control Valve	SBS0131---	RB00562---, RB00563--A, RB00564--- others		1	with Index 2-9
2	10300640	Flow Control Valve	RB00562---			1	
3	10372021	Hex Socket Cap Screw	P330220019	M6X65	MOURI	4	
4	10300655	Dial	RB00563--A			1	
5	10329646	Spring Pin	P337030012	3X12AW	JIS	1	
6	10322120	Socket Set Screw	P330590018	M6X8(Dimple Type)	JIS	2	
7	10300656	Valve Setting Plate	RB00564---			1	
8	10300657	Name Plate	RB00565---			1	
9	10322131	Truss Head Screw	P334130008	M5X10	JIS	4	

Unit No. 41
 Hydraulic(8) <Bellows>

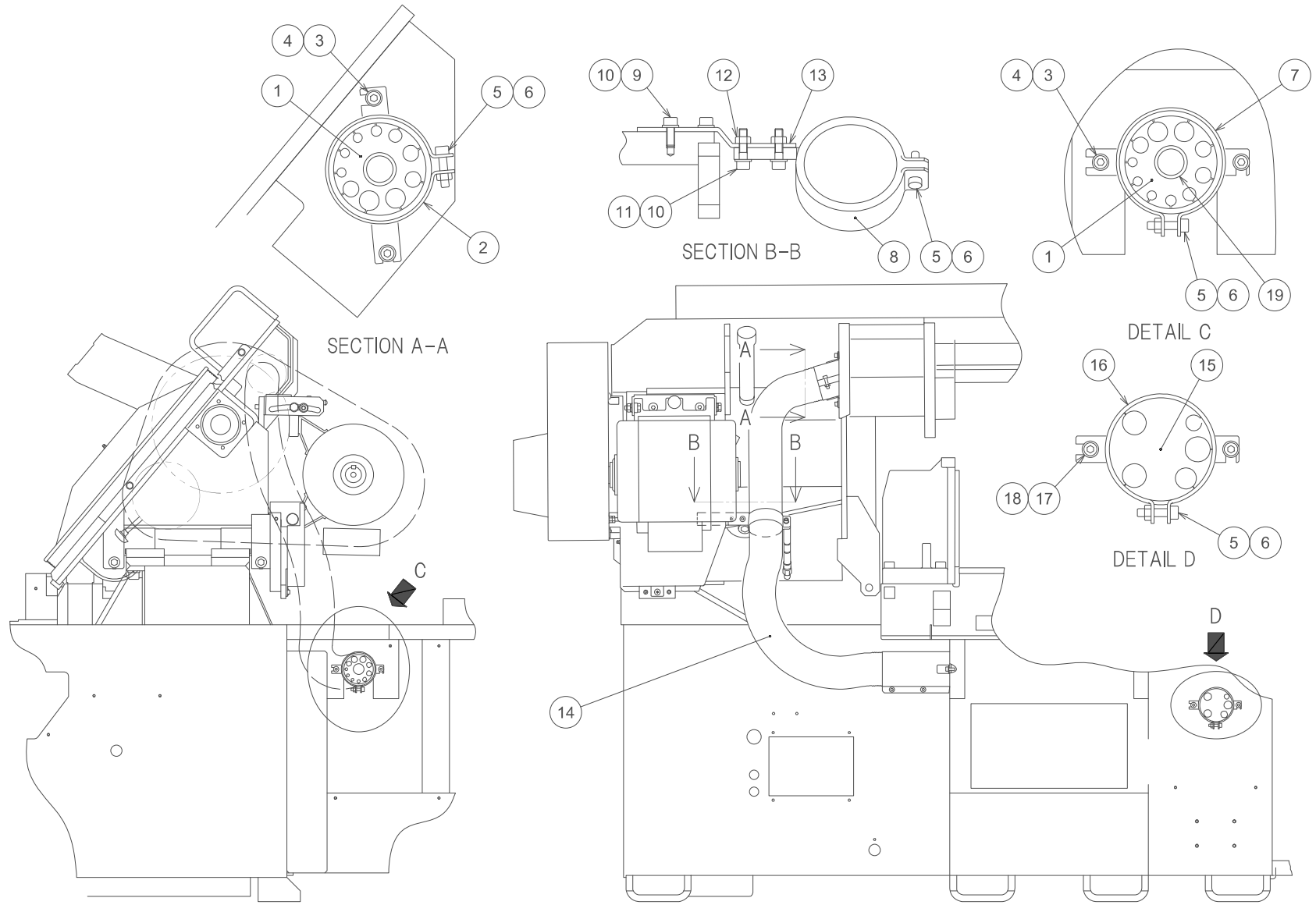

1278792--A

Unit No. 41
Hydraulic(8)

Index	Code	Parts Name	Drawing No.	Type	Maker	Q'ty	Note
1	10578750	Hose Retainer	1109084 A			2	
2	10583661	Bellows Support	1230072 B			1	
3	10323204	Hex Socket Cap Screw	P330220007	M6X16	JIS	4	
4	10321922	Washer	P336000005	6(Normal)	JIS	4	
5	10324622	Hex Socket Cap Screw	P330220011	M6X25		4	
6	10589225	Nut	P332000004	M6	JIS	4	
7	10311165	Bellows Support A	1230074			1	
8	10583662	Pipe Fitting	1230314 A			1	
9	10323204	Hex Socket Cap Screw	P330220007	M6X16	JIS	2	
10	10321922	Washer	P336000005	6(Normal)	JIS	4	
11	10324622	Hex Socket Cap Screw	P330220011	M6X25		2	
12	10589225	Nut	P332000004	M6	JIS	2	
13	10419340	Pipe Fitting Bracket	1238760 A			1	
14	10583663	Bellows Hose	1074443 B			1	
15	10379543	Hose Retainer 1	1238243 B			1	
16	10583664	Bellows Support	1230073			1	
17	10323204	Hex Socket Cap Screw	P330220007	M6X16	JIS	2	
18	10321922	Washer	P336000005	6(Normal)	JIS	2	
19	10583665	Collar	1440029			2	

Unit No. 42

Hydraulic(9) <Slow-start Valve Attachment>

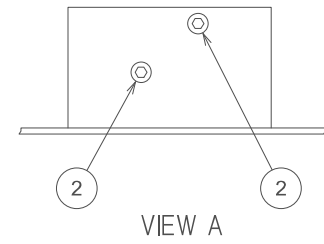
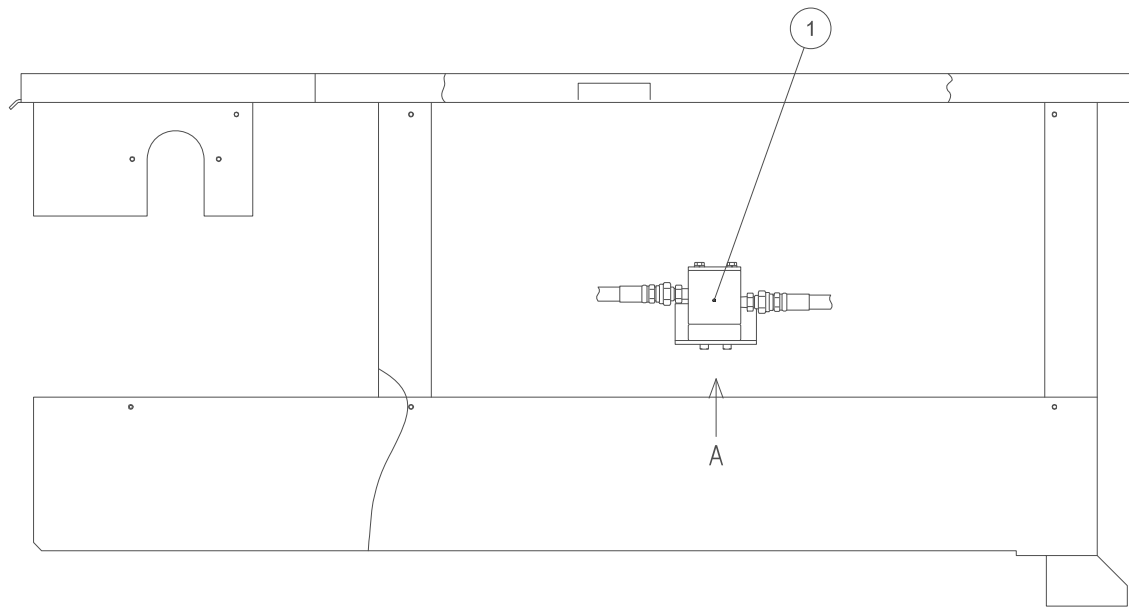

RB02016---

Unit No. 42
Hydraulic(9)

Index	Code	Parts Name	Drawing No.	Type	Maker	Q'ty	Note
1	10301176	Slow-start Valve ASSY	1238572 B			1	
2	10358819	Hex Socket Cap Screw	P330220013	M6X35		2	

Unit No. 43
Hydraulic(10) <Slow-start Valve>

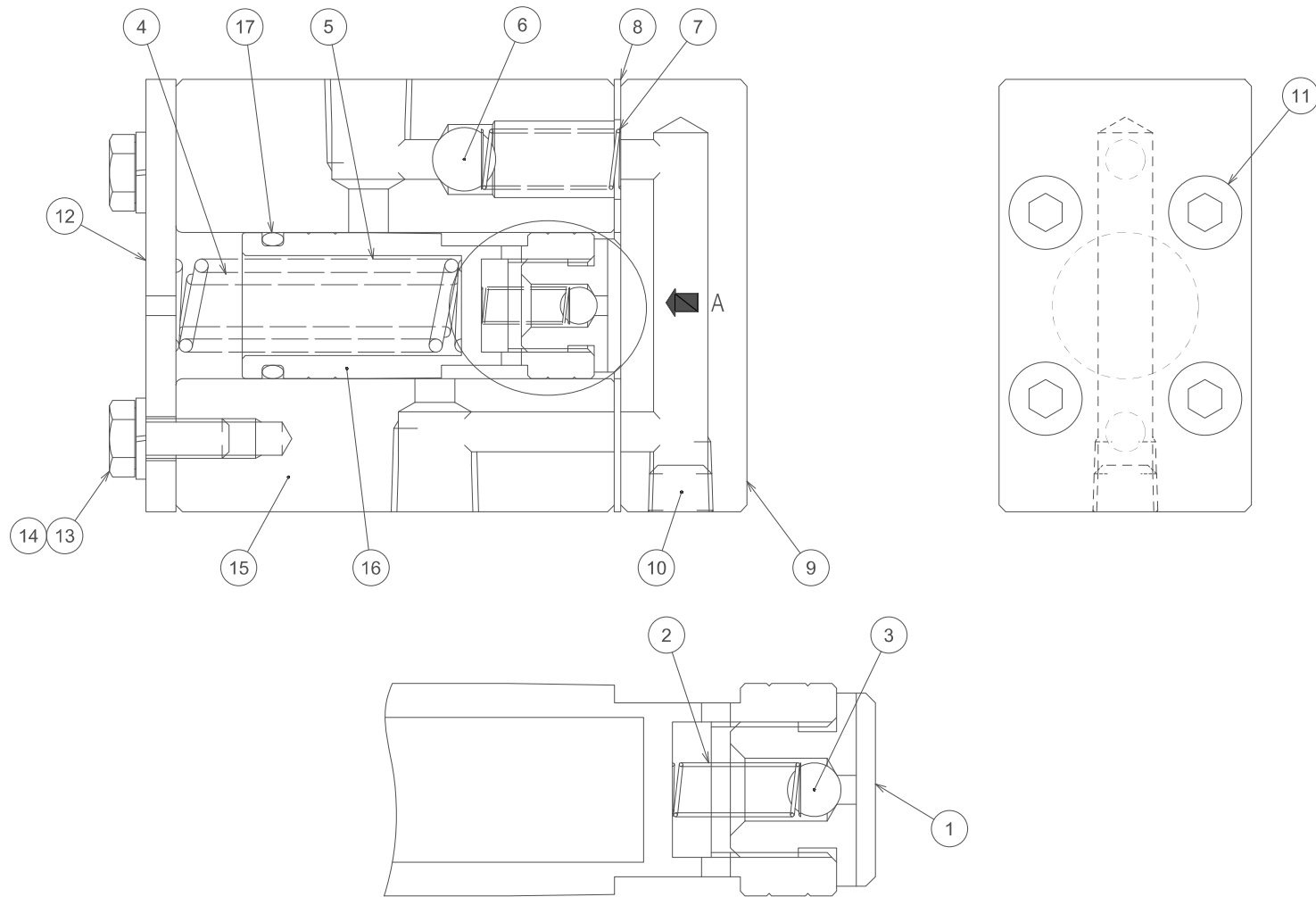

DETAIL A

1238572B

Unit No. 43
Hydraulic(10)

Index	Code	Parts Name	Drawing No.	Type	Maker	Q'ty	Note
1	10419736	Ball Support	0851298 C			1	
2	10419737	Spring	0851299 B			1	
3	10333820	Steel Ball (for Bearing)	P406000003	7/32	JIS	1	
4	10419738	Spring	0851300 A			1	
5	10419739	Spring	0851301 A			1	
6	10380780	Steel Ball (for Bearing)	P406000006	3/8	JIS	1	
7	10419740	Spring	0851303 B			1	
8	10419741	Packing	0851304 B			1	
9	10419742	Cap F	0851305 B			1	
10	10380409	Plug for Piping	P580208022	PT-1/8		1	
11	10324622	Hex Socket Cap Screw	P330220011	M6X25		4	
12	10419743	Cap R	0851306 A			1	
13	10371906	Bolt	P330020006	M6X16	JIS	2	
14	10310351	Spring Washer	P336050005	6	JIS	2	
15	10419744	Valve Body	0851296 D			1	
16	10419745	Spool	0851297 C			1	
17	10001124	O Ring	P590000017	P18		1	

Unit No. 44
Swing Cylinder

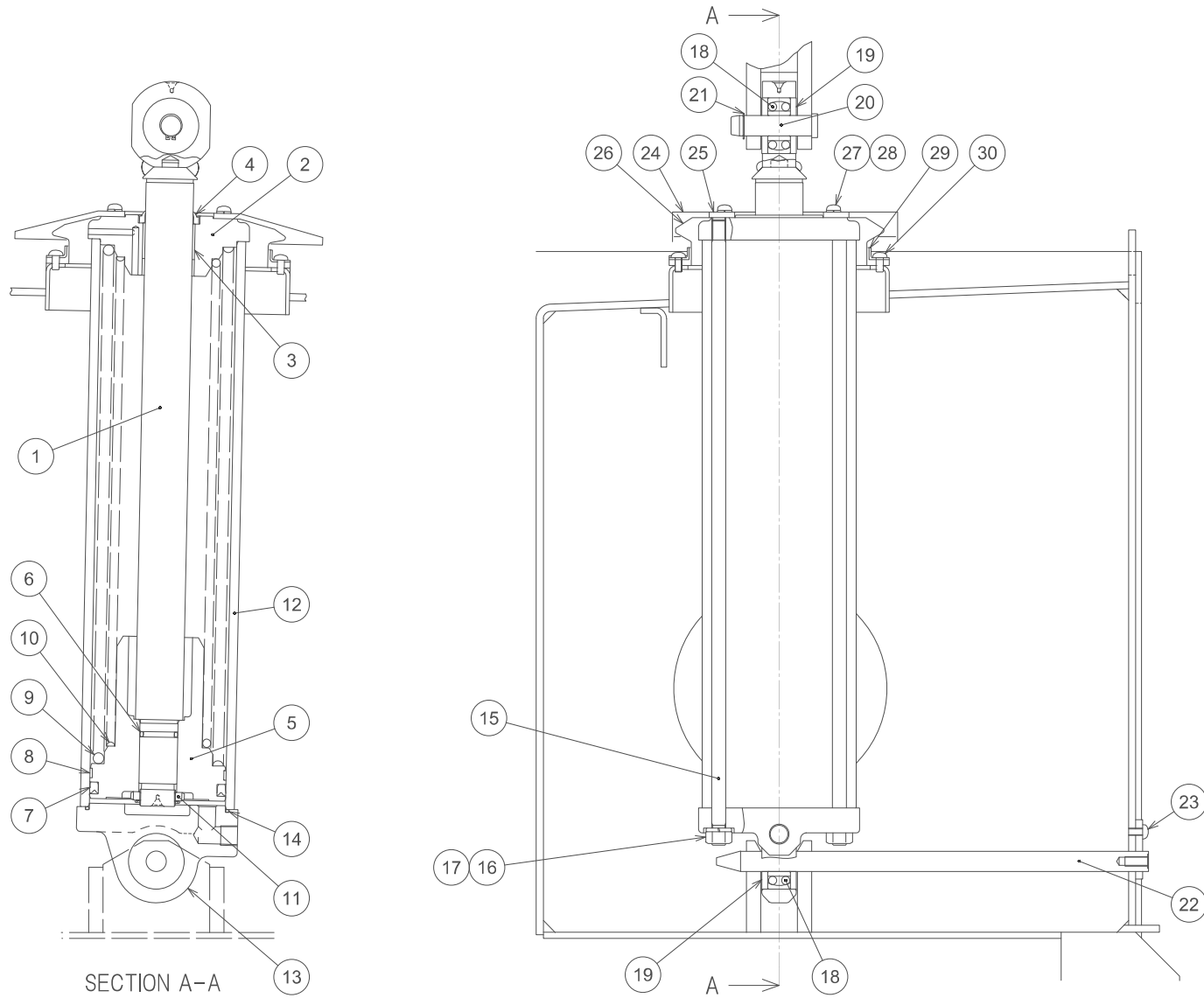

Unit No. 44
Swing Cylinder

Index	Code	Parts Name	Drawing No.	Type	Maker	Q'ty	Note
1	10378263	Piston Rod	1238338 A			1	
2	10329819	Upper Cylinder Cap	1230422 C			1	
3	10583666	Plain Bearing	P407003192	DUB4030	DAIDO METAL	1	
4	10330117	Wiper Ring	P590312008	DKI-40	NOK	1	
5	10378261	Piston	1238336 A			1	
6	10001121	O Ring	P590000026	P26		1	
7	10380559	Piston Packing	P590403056	SKY-100	SAKAGAMI	1	
8	10378268	Wearing	7922625		SAKAGAMI	1	
9	10329827	Sawhead Cylinder Spring 1	1230433			1	
10	10329828	Sawhead Cylinder Spring 2	1230434			1	
11	10301294	Lock Nut	P406168011	FU06SC	FUJI SEIMITSU	1	
12	10378262	Cylinder	1238337			1	
13	10421543	Lower Cylinder Cap	1230426 G			1	
14	10330004	O Ring	P590010019	G115		1	
15	10378264	Tie Rod Bolt	1238339	D12X528L		4	
16	10000829	Spring Washer	P336050008	12	JIS	4	
17	10589227	Nut	P332000007	M12	JIS	4	
18	10316429	Ball Bearing	P400077004	2303	NSK	2	
19	10316506	Bearing Retainer	0604338			4	

Unit No. 44
Swing Cylinder

Index	Code	Parts Name	Drawing No.	Type	Maker	Q'ty	Note
20	10378266	Hinge Shaft	1238341			1	
21	10316009	Locating Snap Ring	P406108040	STW-17	OCHIAI	1	
22	10378265	Flange Pin	1238340			1	
23	10340019	Truss Head Screw	P334130012	M6X12	JIS	1	
24	10378267	Cylinder Cover	1238342			1	
25	10419528	Reinforcement Plate	1280399			1	
26	10329841	Rectangle Bellows	1230430			1	
27	10322226	Pan Head Screw	P334100055	M6X12	JIS	4	
28	10310351	Spring Washer	P336050005	6	JIS	4	
29	10329843	Bellows Support	1230431 A			1	
30	10322226	Pan Head Screw	P334100055	M6X12	JIS	8	

Unit No. 45
Wire Brush-1/2

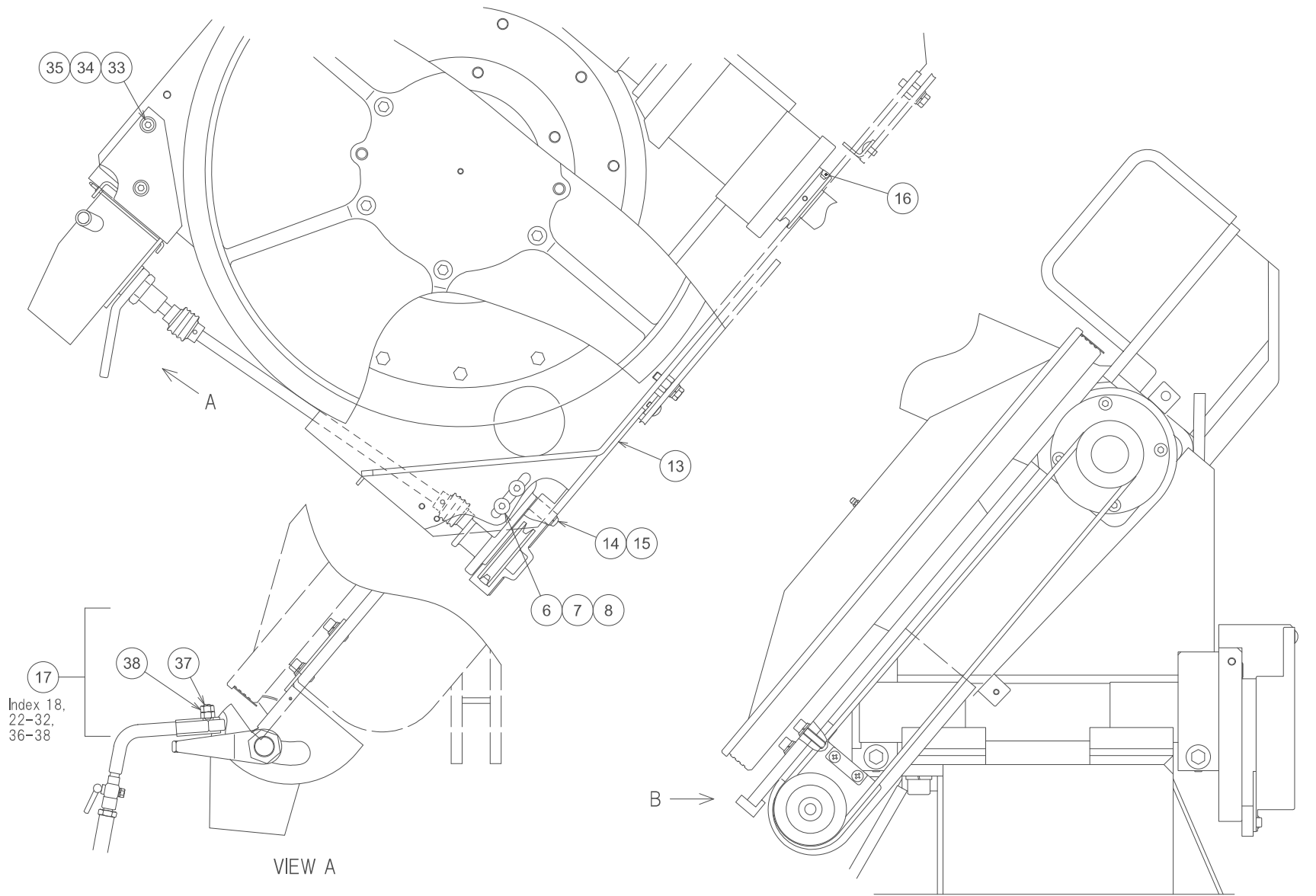

Unit No. 45
Wire Brush-2/2

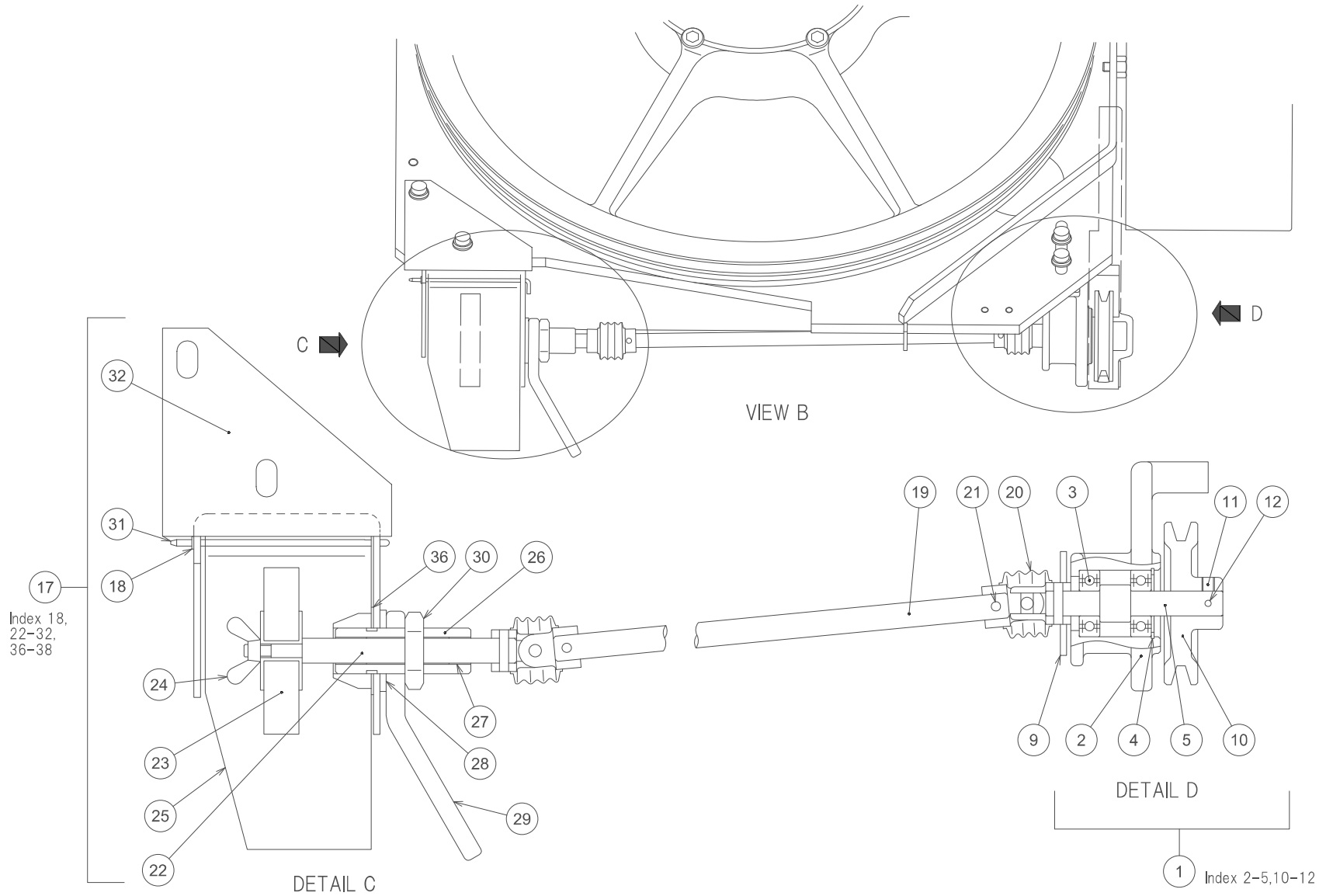

1278740--A

Unit No. 45

Wire Brush

Index	Code	Parts Name	Drawing No.	Type	Maker	Q'ty	Note
1	10302100	Pulley Bracket ASSY	SBS0132---	1230519 B, P400010760 others		1	with Index 2-5,10-12
2	10583667	Bearing Bracket	1230519 B			1	
3	10335427	Deep Groove Ball Bearing	P400010760	6201DDU	NSK(equality)	2	
4	10314126	Locating Snap Ring	P406108010	RTW-32	OCHIAI	1	
5	10581718	Pulley Shaft	0604555 C			1	
6	10330101	Hex Socket Cap Screw	P330230008	M8X30		2	
7	10321923	Washer	P336000006	8(Normal)	JIS	2	
8	10001521	Spring Washer	P336050006	8	JIS	2	
9	10301143	Seal Rubber	1105591 B			1	
10	10301142	Brush Pulley	0604554 A			1	
11	10322120	Socket Set Screw	P330590018	M6X8(Dimple Type)	JIS	1	
12	10372134	Spring Pin	P337030043	5X25AW	JIS	1	
13	10583668	Pulley Cover	1230726 C			1	
14	10322226	Pan Head Screw	P334100055	M6X12	JIS	2	
15	10310351	Spring Washer	P336050005	6	JIS	2	
16	10380583	V-belt	P223000016	M48		1	
17	10302101	Brush Cover ASSY	SBS0133--	1230516 A, RB00609---, 1238399 others		1	with Index 18,22-32,36-38
18	10380568	Push Nut	QZZ036537	D3for shaft	MOURI	1	
19	10314033	Shaft	1230517			1	

Unit No. 45

Wire Brush

Index	Code	Parts Name	Drawing No.	Type	Maker	Q'ty	Note
20	10583669	Universal Joint	7720525		KYOWA	2	
21	10356502	Spring Pin	P337030041	5X20AW	JIS	4	
22	10314108	Brush Shaft	1230516 A			1	
23	10300687	Wire Brush	RB00609---			1	
24	10583670	Wing Nut	P338030012	M6(Type-1A)	JIS	1	
25	10376370	Brush Cover	1238399			1	
26	10314306	Brush Shaft Support	1230512 B			1	
27	10581022	Plain Bearing	P407003148	DUB1215	DAIDO METAL	2	
28	10380584	Washer	P336000077	22(Polished Round)	JIS	1	
29	10314315	Lock Lever	1230513 B			1	
30	10335530	Nut M22X1.5	1230520			1	
31	10335246	Cover Hinge Pin	1230515 A			1	
32	10583671	Brush Bracket	1230728 A			1	
33	10322202	Hex Socket Cap Screw	P330230006	M8X20		2	
34	10321923	Washer	P336000006	8(Normal)	JIS	2	
35	10001521	Spring Washer	P336050006	8	JIS	2	
36	10380588	Bearing Ring	P406127021	FTRA-2542	NSK	1	
37	10583672	Ball Plunger	P338116011	BSR8X30	IMAO Mfg	1	
38	10589226	Nut	P332000005	M8	JIS	1	

Unit No. 46
Cutting Fluid(1) <Coolant Pump>

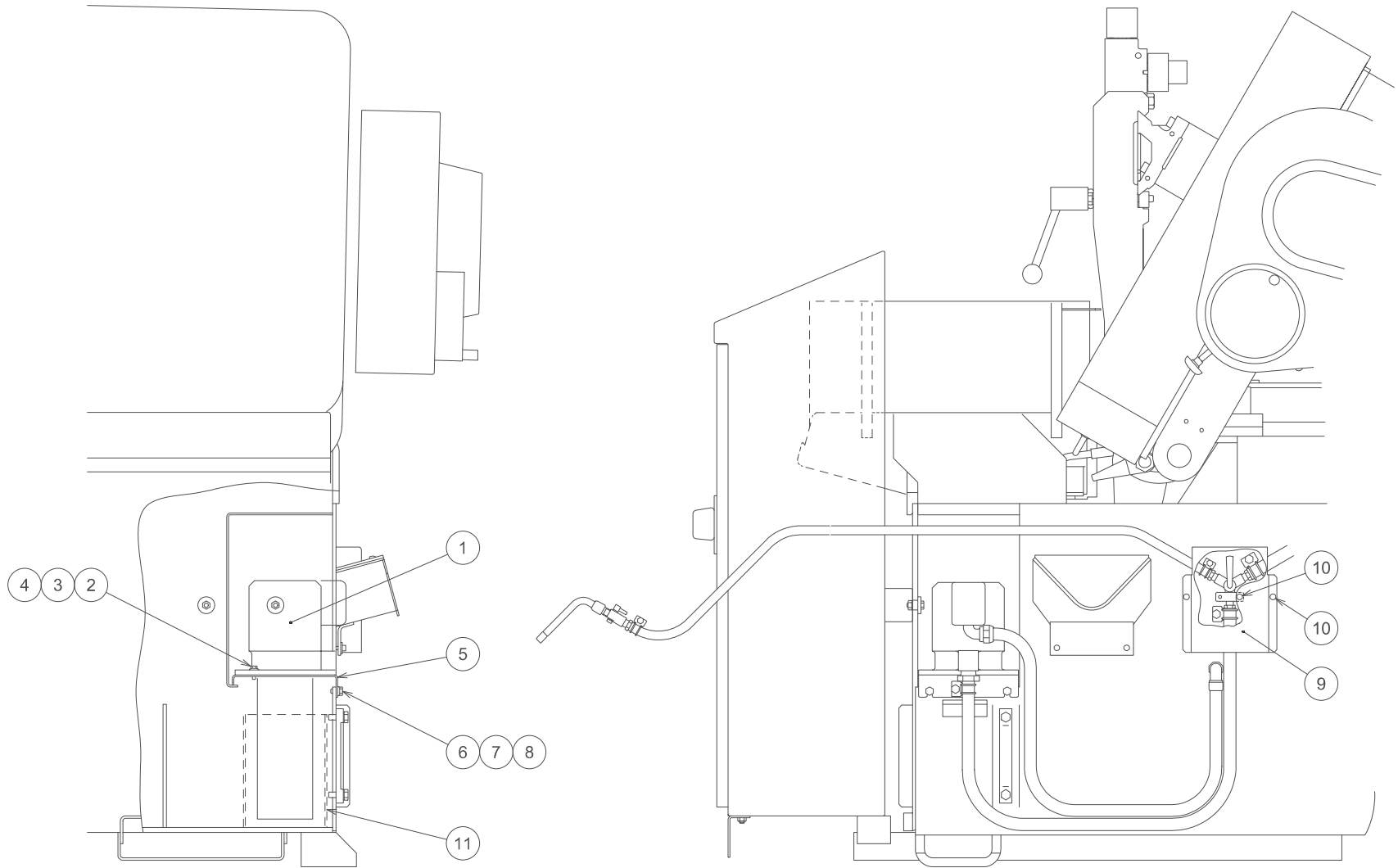

1278796--A

Unit No. 46
Cutting Fluid(1)

Index	Code	Parts Name	Drawing No.	Type	Maker	Q'ty	Note
1	10301487	Coolant Pump	RB02051--A	DB-40A(180W)		1	
2	10371906	Bolt	P330020006	M6X16	JIS	2	
3	10321923	Washer	P336000006	8(Normal)	JIS	2	
4	10310351	Spring Washer	P336050005	6	JIS	2	
5	10301488	Motor Base	RB02052--A			1	
6	10325826	Bolt	P330030006	M8X20		2	
7	10321923	Washer	P336000006	8(Normal)	JIS	2	
8	10001521	Spring Washer	P336050006	8	JIS	2	
9	10583674	Cock Setting Plate	1230550 C			1	
10	10322226	Pan Head Screw	P334100055	M6X12	JIS	4	
11	10360954	Bucket	1295265 B			1	

Unit No. 47
Cutting Fluid(2) <Power Source Voltage:230/460V>

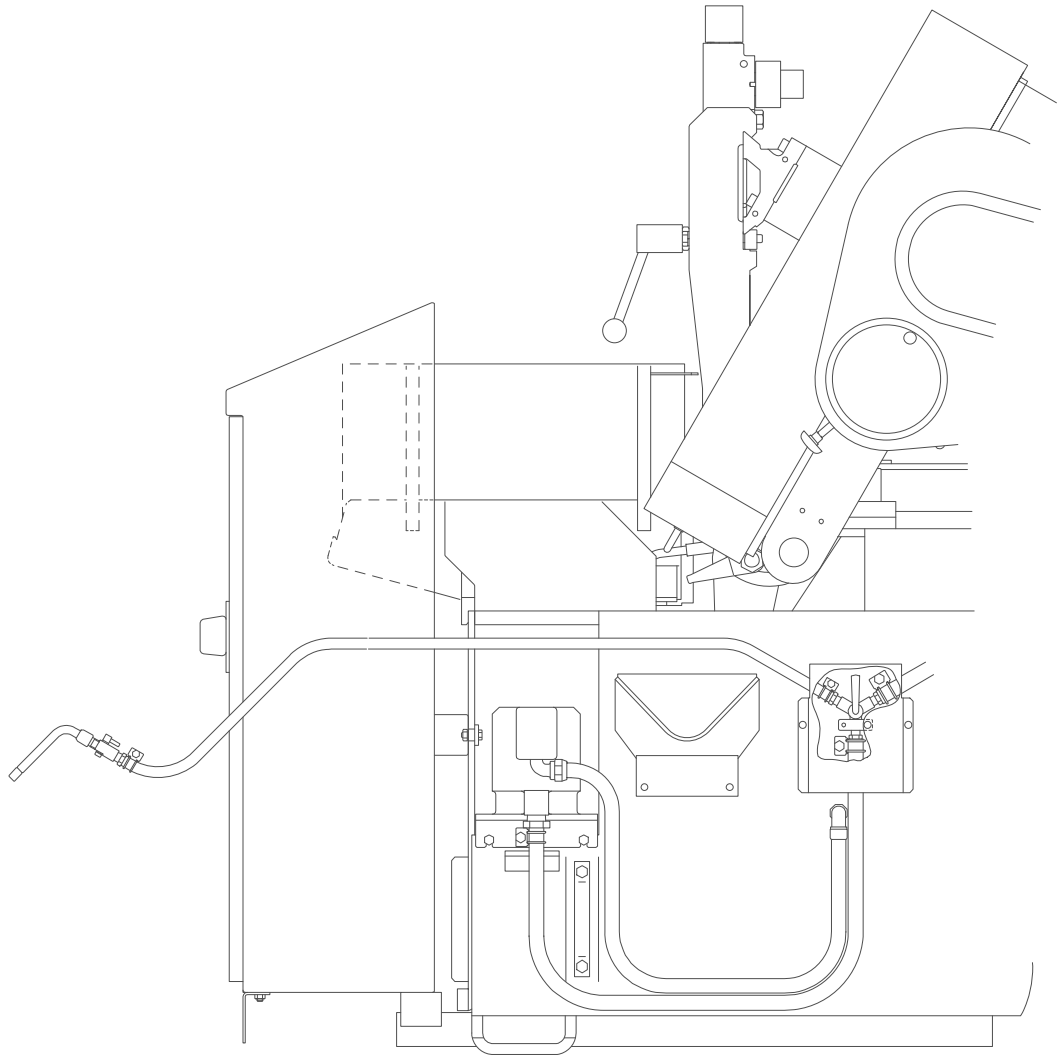
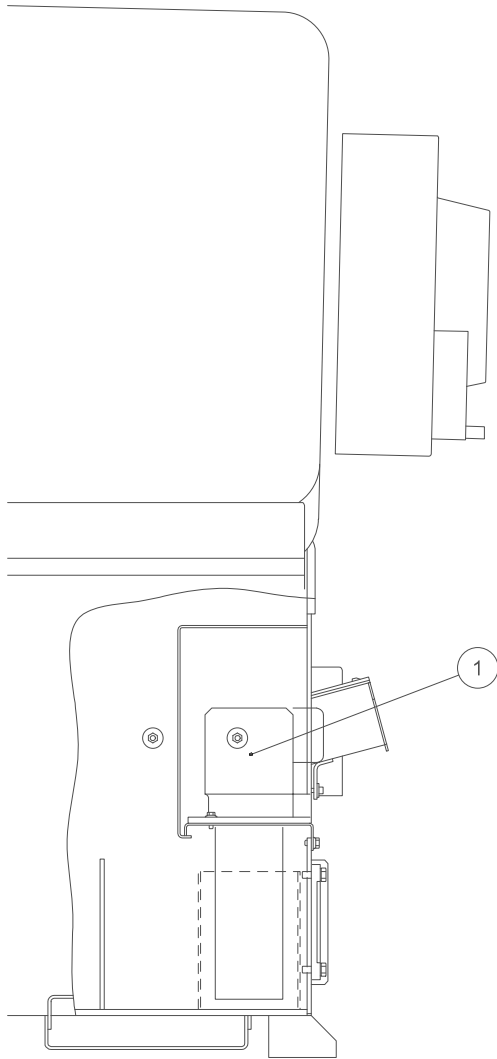

RB02428---
(1278796---A)

Unit No. 47
Cutting Fluid(2)

Index	Code	Parts Name	Drawing No.	Type	Maker	Q'ty	Note
1	10301517	Coolant Pump US	RB02428---	180W 230/460V(60Hz)		1	

Unit No. 48

Cutting Fluid(3) <Power Source Voltage:400V>

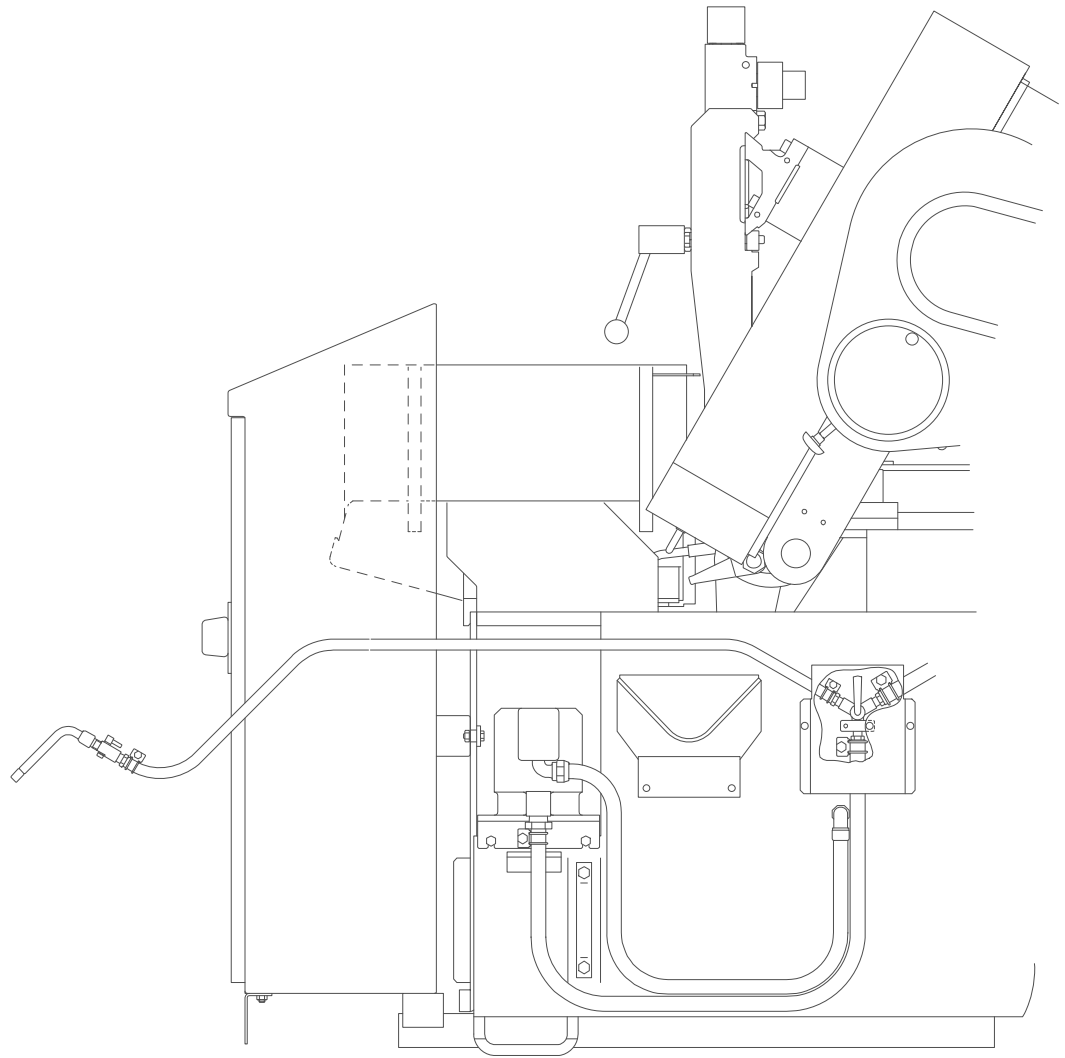
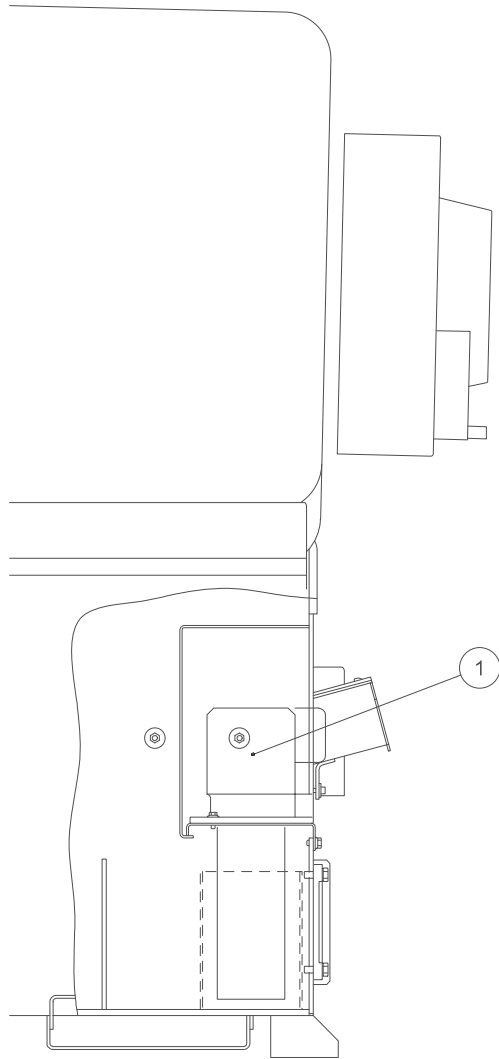

RB02478---
(1278796---A)

Unit No. 48
Cutting Fluid(3)

Index	Code	Parts Name	Drawing No.	Type	Maker	Q'ty	Note
1	10301525	Coolant Pump 400V	RB02478---	180W 400V(50Hz)		1	

Unit No. 49
Cutting Fluid(4) <Piping>

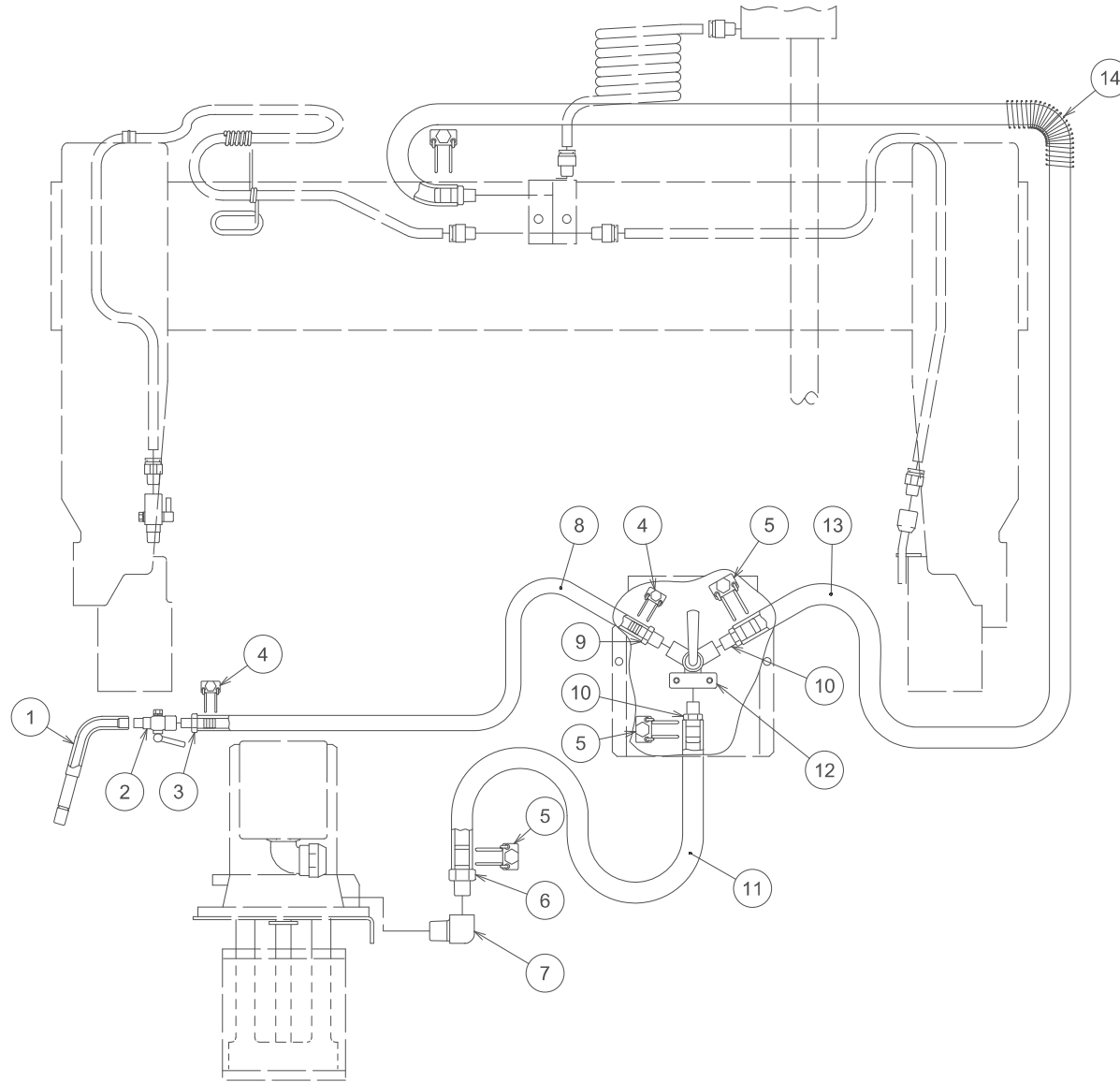

1278797--C

Unit No. 49
Cutting Fluid(4)

Index	Code	Parts Name	Drawing No.	Type	Maker	Q'ty	Note
1	10382813	Nozzle	1279090			1	
2	10583681	P-cock	124469717B			1	
3	10583680	Vinyl Hose Connector	124469716			1	
4	10380357	Hose Band	P381008029	AK-1016	SUGITAVALVE	2	
5	10380603	Hose Band	P381008028	AK-1022	SUGITAVALVE	3	
6	10301325	Vinyl Hose Connector	RB0062705-			1	
7	10301326	Elbow	RB0062706-	PT1/2-PF1/2		1	
8	10301372	Blade Hose	RB0169014A			1	
9	10205212	Vinyl Hose Connector	0800087 A			1	
10	10380604	Joint	P589420011	PT1/4-D=16-BSBM		2	
11	10301371	Blade Hose	RB0169013A			1	
12	10205114	3-way Cock	0604593 A		YBSC2	1	
13	10301370	Blade Hose	RB0169012A			1	
14	10301180	Hose Guard	1244713--A			1	

Unit No. 50
Cutting Fluid(5) <Saw Blade Guide Piping>

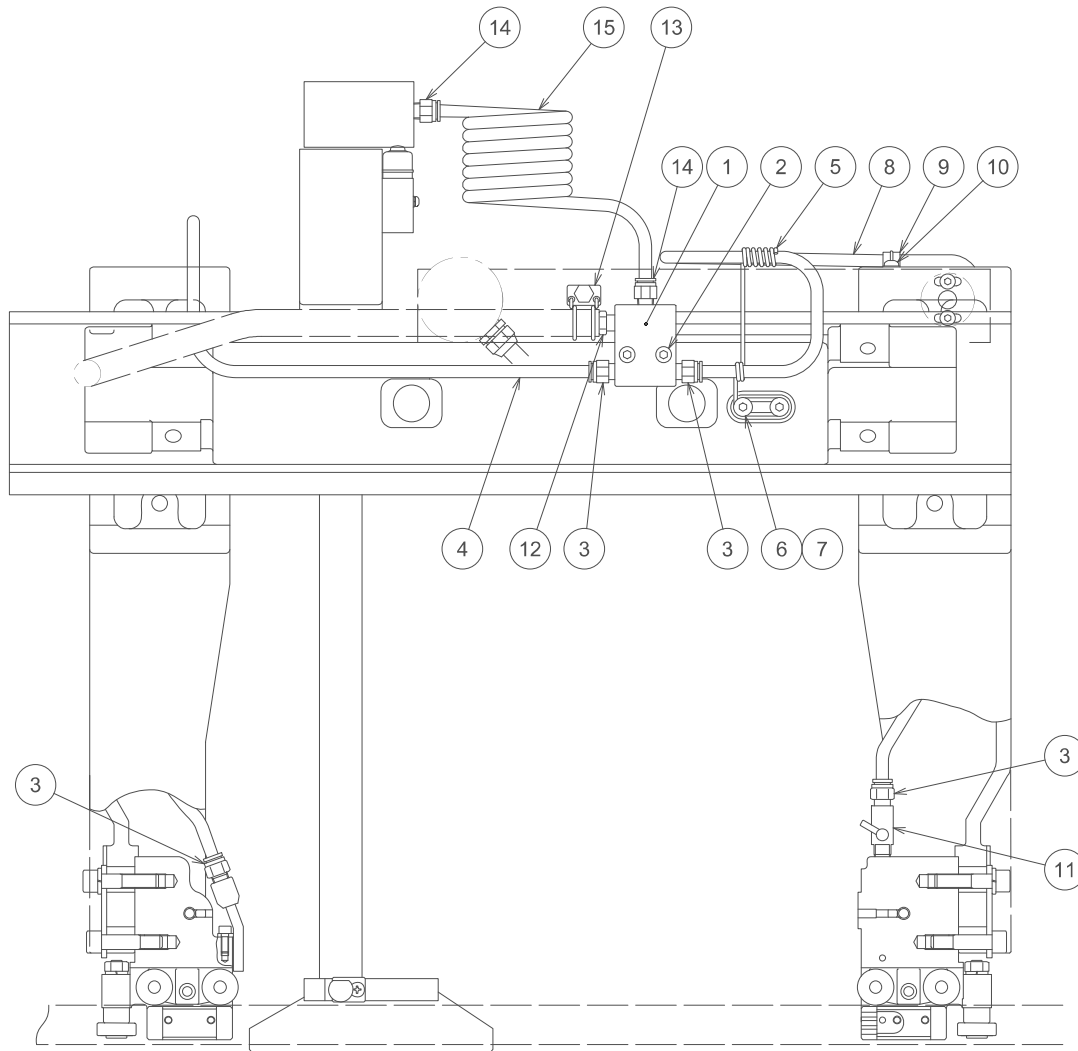

1278798--A

Unit No. 50
Cutting Fluid(5)

Index	Code	Parts Name	Drawing No.	Type	Maker	Q'ty	Note
1	10378333	Piping Block	1238423			1	
2	10323207	Hex Socket Cap Screw	P330230010	M8X40		2	
3	10583676	One Touch Fitting	124469715			4	
4	10301321	Nylon Flexible Tube	QZZ036538	(99048360)N5-4	NITTA MOORE	1	
5	10378332	Hose Support	1238422			1	
6	10322202	Hex Socket Cap Screw	P330230006	M8X20		2	
7	10321923	Washer	P336000006	8(Normal)	JIS	2	
8	10380597	Cutting Fluid Tube	1238421			1	
9	10329206	Saddle for Conduit	P381017001	CH-6	DAIWA DENGYO	1	
10	10322226	Pan Head Screw	P334100055	M6X12	JIS	1	
11	10583675	P-cock	124469711			1	
12	10380604	Joint	P589420011	PT1/4-D=16-BSBM		1	
13	10380603	Hose Band	P381008028	AK-1022	SUGITAVALVE	1	
14	10583676	One Touch Fitting	124469715			2	
15	10378331	Coil Tube	1238420			1	

Unit No. 51
 Work Feeding Unit(1)-1/2

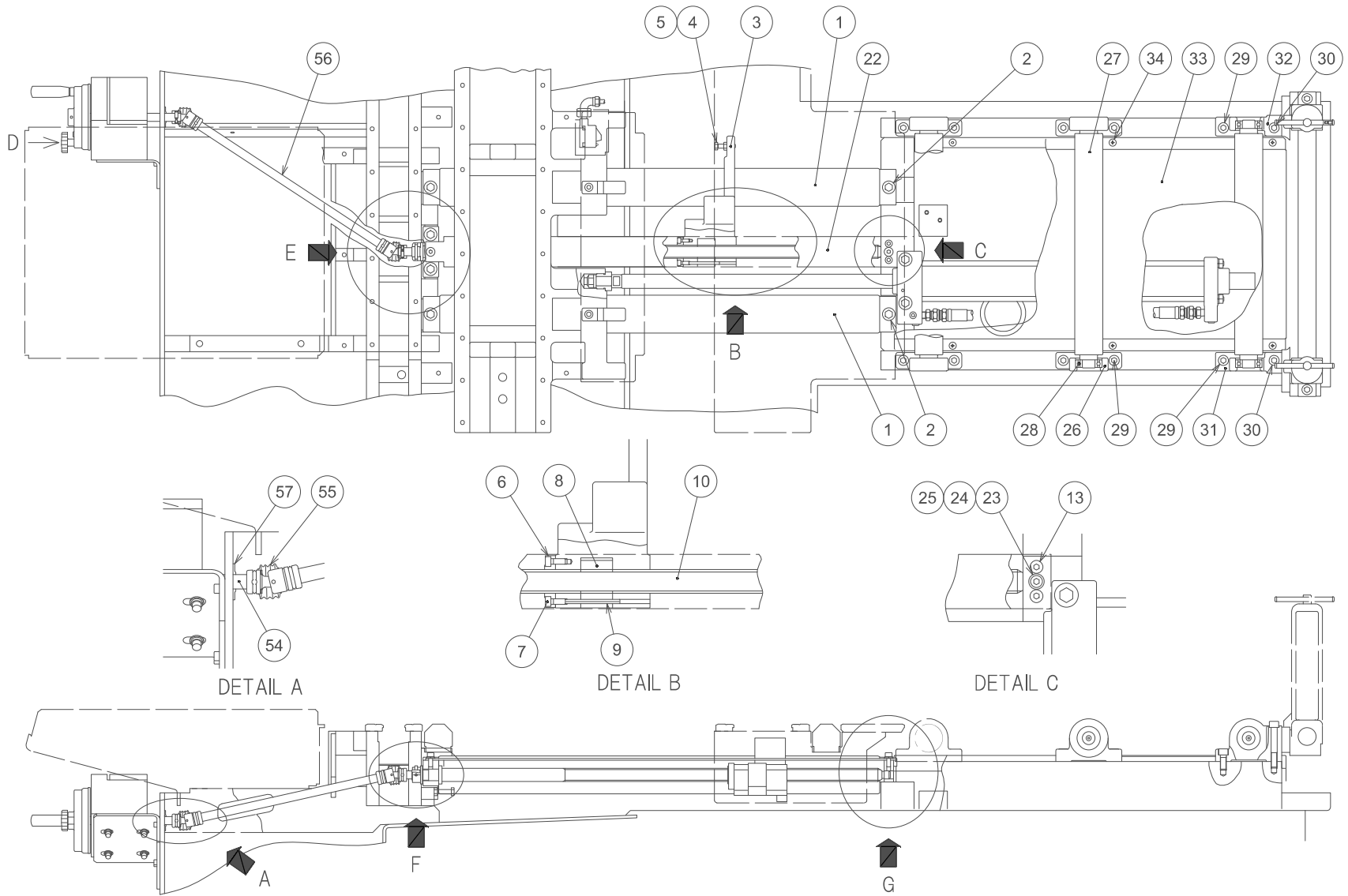

1278803--A

Unit No. 51
 Work Feeding Unit(1)-2/2

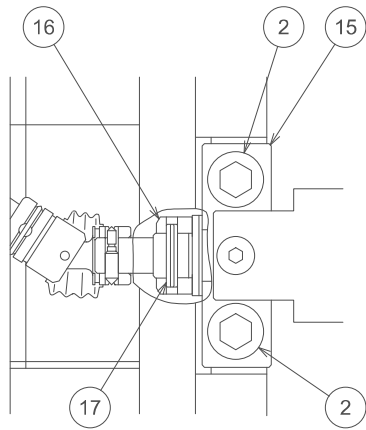

DETAIL E

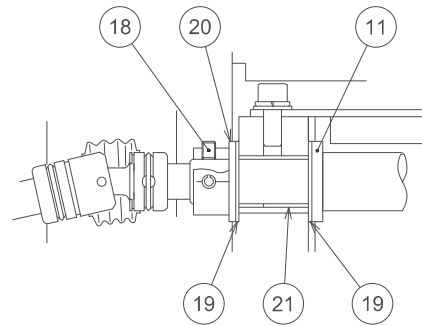

DETAIL F

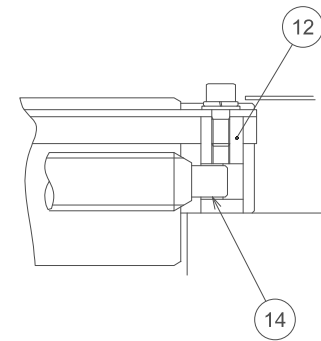

DETAIL G

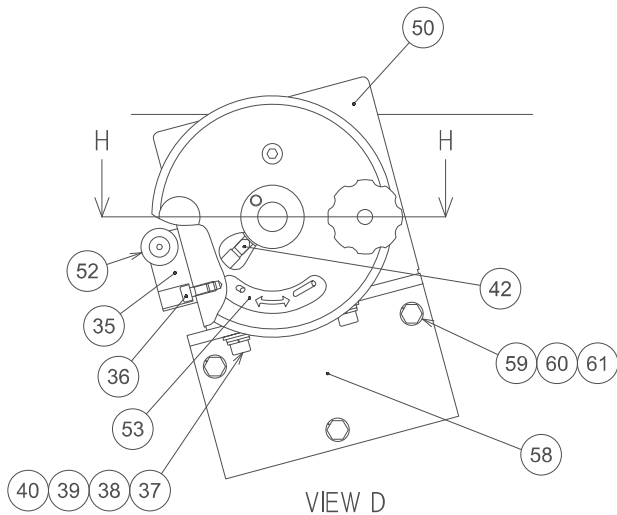

VIEW D

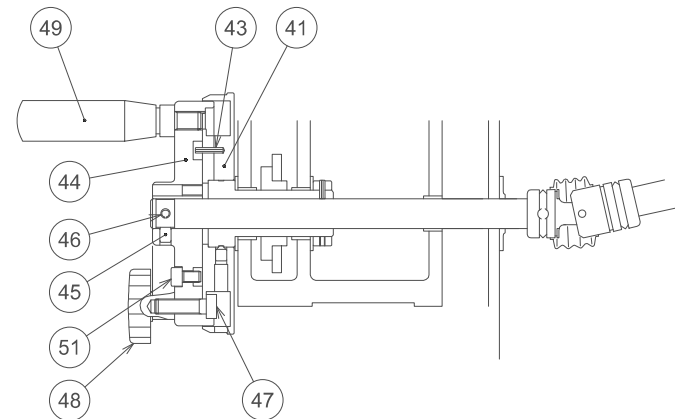

SECTION H-H

1278803--A

Unit No. 51

Work Feeding Unit(1)

Index	Code	Parts Name	Drawing No.	Type	Maker	Q'ty	Note
1	10301489	Guide Shaft	RB02081--A			2	
2	10583160	Reamer Bolt	1230007 B			6	
3	10380862	Stopper Bracket	1238446 C			1	
4	10301279	Bolt	P330030010	M8X35(All-thread)	MOURI	1	
5	10589226	Nut	P332000005	M8	JIS	1	
6	10331611	Pusher	1230578			1	
7	10312831	Hex Socket Cap Screw	P330220006	M6X15		2	
8	10319202	Screw Bushing	0603142 A			1	
9	10332130	Spring Pin	P337030053	5X60AW	OHKITA	1	
10	10583684	Gauge Screw	1230772 A			1	
11	10331637	Collar	1230583			1	
12	10331626	Screw Supporter R	1230580			1	
13	10330101	Hex Socket Cap Screw	P330230008	M8X30		2	
14	10589707	Plain Bearing	P407003151	DUB1410	DAIDO METAL	1	
15	10379546	Screw Supporter F	1230581 B			1	
16	10321966	Nut	0603150	M20 (Type-1) Add Works		1	
17	10332129	Spring Pin	P337030044	5X28AW	JIS	1	
18	10322120	Socket Set Screw	P330590018	M6X8(Dimple Type)	JIS	1	
19	10583685	Plain Bearing	P407023026	DUT18	DAIDO METAL	2	

Unit No. 51

Work Feeding Unit(1)

Index	Code	Parts Name	Drawing No.	Type	Maker	Q'ty	Note
20	10301281	Washer	P336000038	20(Polished Round)	JIS	1	
21	10300166	Plain Bearing	P407003232	DUB2020	DAIDO METAL	1	
22	10583686	Screw Cover	1230773 A			1	
23	10325826	Bolt	P330030006	M8X20		2	
24	10321923	Washer	P336000006	8(Normal)	JIS	2	
25	10001521	Spring Washer	P336050006	8	JIS	2	
26	10319140	Roller Bracket	1105660 B			4	
27	10378346	Roller	1238451 A			3	
28	10301289	Deep Groove Ball Bearing	P400010556	6205ZZ	NTN & others	6	
29	10322203	Hex Socket Cap Screw	P330250005	M12X30		10	
30	10000830	Hex Socket Cap Screw	P330250015	M12X80		2	
31	10331649	Roller Bracket R,RM	1230589 A			1	
32	10428833	Roller Bracket R,L	1230590 B			1	
33	10583687	Cylinder Cover	1230688 A			1	
34	10340019	Truss Head Screw	P334130012	M6X12	JIS	6	
35	10331516	Stopper Block	1230596 A			1	
36	10301280	Hex Socket Cap Screw	P330213002	M5X10	SPS/UNBRAKO	2	
37	10312832	Hex Socket Cap Screw	P330220009	M6X20	JIS	4	
38	10321922	Washer	P336000005	6(Normal)	JIS	4	

Unit No. 51

Work Feeding Unit(1)

Index	Code	Parts Name	Drawing No.	Type	Maker	Q'ty	Note
39	10310351	Spring Washer	P336050005	6	JIS	4	
40	10321923	Washer	P336000006	8(Normal)	JIS	4	
41	10331506	Collar	1230593 A			1	
42	10326707	Socket Set Screw	P330580019	M6X8(Sharp Type)	JIS	2	
43	10339123	Spring Pin	P337030014	3X15AW	OHKITA	1	
44	10319418	Handle	1230594 B			1	
45	10322120	Socket Set Screw	P330590018	M6X8(Dimple Type)	JIS	1	
46	10332129	Spring Pin	P337030044	5X28AW	JIS	1	
47	10332064	Square Bolt	P330130001	M8X27	JIS	1	
48	10332060	Knob	P317294003	EK40T	IMAO Mfg	1	
49	10332055	Knob	P317264003	ER22	IMAO Mfg	1	
50	10300108	Backgauge Counter	7720527---	A-4007(BG-24(2)E	LINE SEIKI	1	mm
50	10583689	Counter mm/inch	7720562	A-4007(BG-224(2)	LINE SEIKI	1	inch
51	10589206	Hex Socket Cap Screw	P330220003	M6X10		1	
52	10319314	Lock Knob	0011013 A			1	
53	10331861	Sticker	0655878			1	
54	10380628	Handle Shaft	1238449 A			1	
55	10583691	Universal Joint	7720531	NC-14-21DK(NC14-RRC-24)	KYOWA Industry	2	
56	10380629	Shaft	1238450 B			1	

Unit No. 51

Work Feeding Unit(1)

Index	Code	Parts Name	Drawing No.	Type	Maker	Q'ty	Note
57	10331756	Seal Ring	1230599			1	
58	10583692	Counter Bracket	1230600 C			1	
59	10332109	Bolt	P330020005	M6X15		3	
60	10321922	Washer	P336000005	6(Normal)	JIS	3	
61	10310351	Spring Washer	P336050005	6	JIS	3	

Unit No. 52
Work Feeding Unit(2) <HA400W>

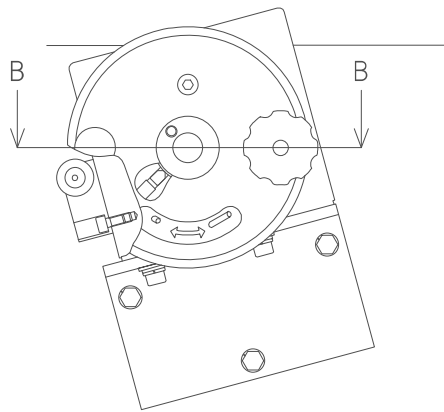
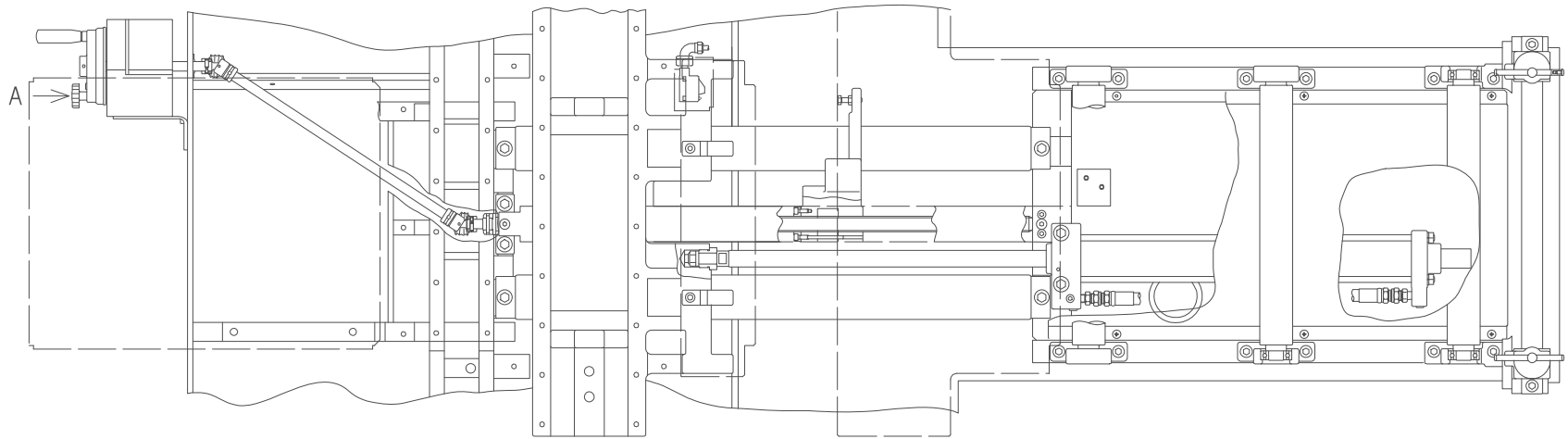

VIEW A

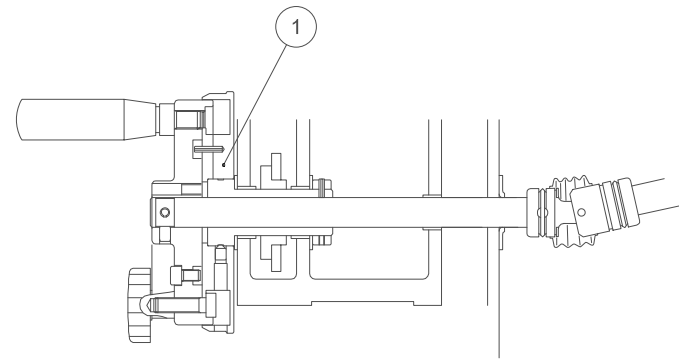

SECTION B-B

1278803--A

Unit No. 52

Work Feeding Unit(2)

Index	Code	Parts Name	Drawing No.	Type	Maker	Q'ty	Note
1	10301514	Collar 1.3T	RB02386---			1	

Unit No. 53
Feed Cylinder(1)

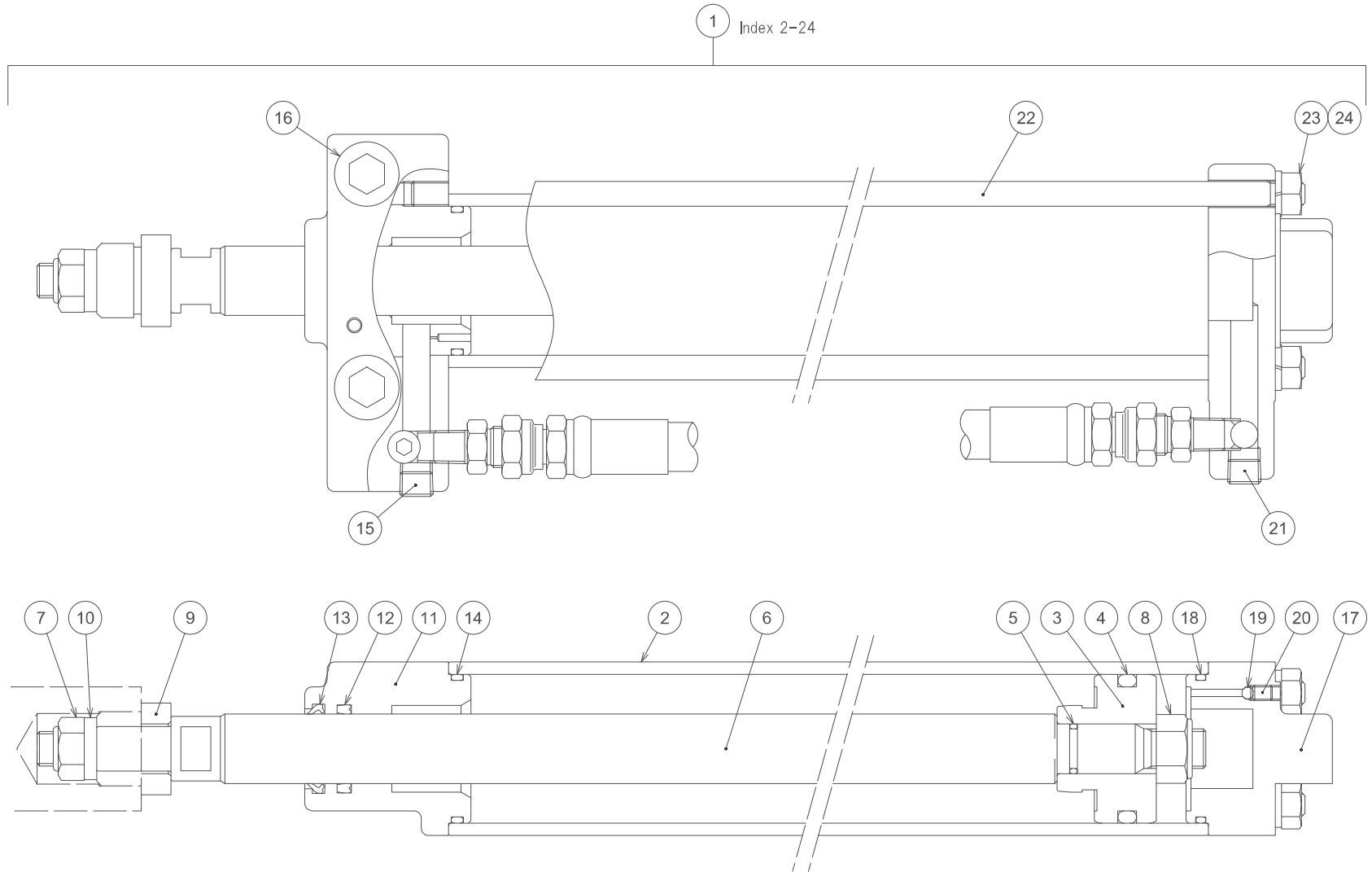

1278804---

Unit No. 53

Feed Cylinder(1)

Index	Code	Parts Name	Drawing No.	Type	Maker	Q'ty	Note
1	10302102	Feed Cylinder ASSY	SBS0134---	1230612 A, 1108574 B, 1238501 others		1	with Index 2-24
2	10583694	Cylinder	1230612 A			1	
3	10583695	Piston	1108574 B			1	
4	10207507	O Ring	P590000050	P50A		1	
5	10589448	O Ring	P590000018	P20		1	
6	10583696	Piston Rod	1230613 A			1	
7	10382418	Locking Nut	P332505023	M14(Type-1)	FUJI SEIMITSU	1	
8	10380665	Locking Nut	P332505026	M16(Type-1)-SK5	FUJI SEIMITSU	1	
9	10376389	Bushing Nut	1108576 C			1	
10	10376756	Washer	1108577			1	
11	10378383	Cylinder Cap F	1238501			1	
12	10317519	Wiper Ring	P590312003	DKI-28	NOK	1	
13	10333005	Piston Packing	P590403021	SKY-28	SAKAGAMI	1	
14	10001116	O Ring	P590010007	G55		1	
15	10300171	Plug for Piping	P580208021	PT-1/4		2	
16	10583160	Reamer Bolt	1230007 B			2	
17	10378384	Cylinder Cap R	1238502			1	
18	10001116	O Ring	P590010007	G55		1	
19	10332944	Steel Ball (for Bearing)	P406000002	3/16	JIS	1	

Unit No. 53

Feed Cylinder(1)

Index	Code	Parts Name	Drawing No.	Type	Maker	Q'ty	Note
20	10326708	Socket Set Screw	P330570062	M6X8(Dog-end)	JIS	1	
21	10300171	Plug for Piping	P580208021	PT-1/4		2	
22	10583697	Tie Rod	1230614 A			4	
23	10427991	Nut	P332000006	M10	JIS	4	
24	10001520	Spring Washer	P336050007	10	JIS	4	

Unit No. 54

Feed Cylinder(2) <EU Specification Machine>

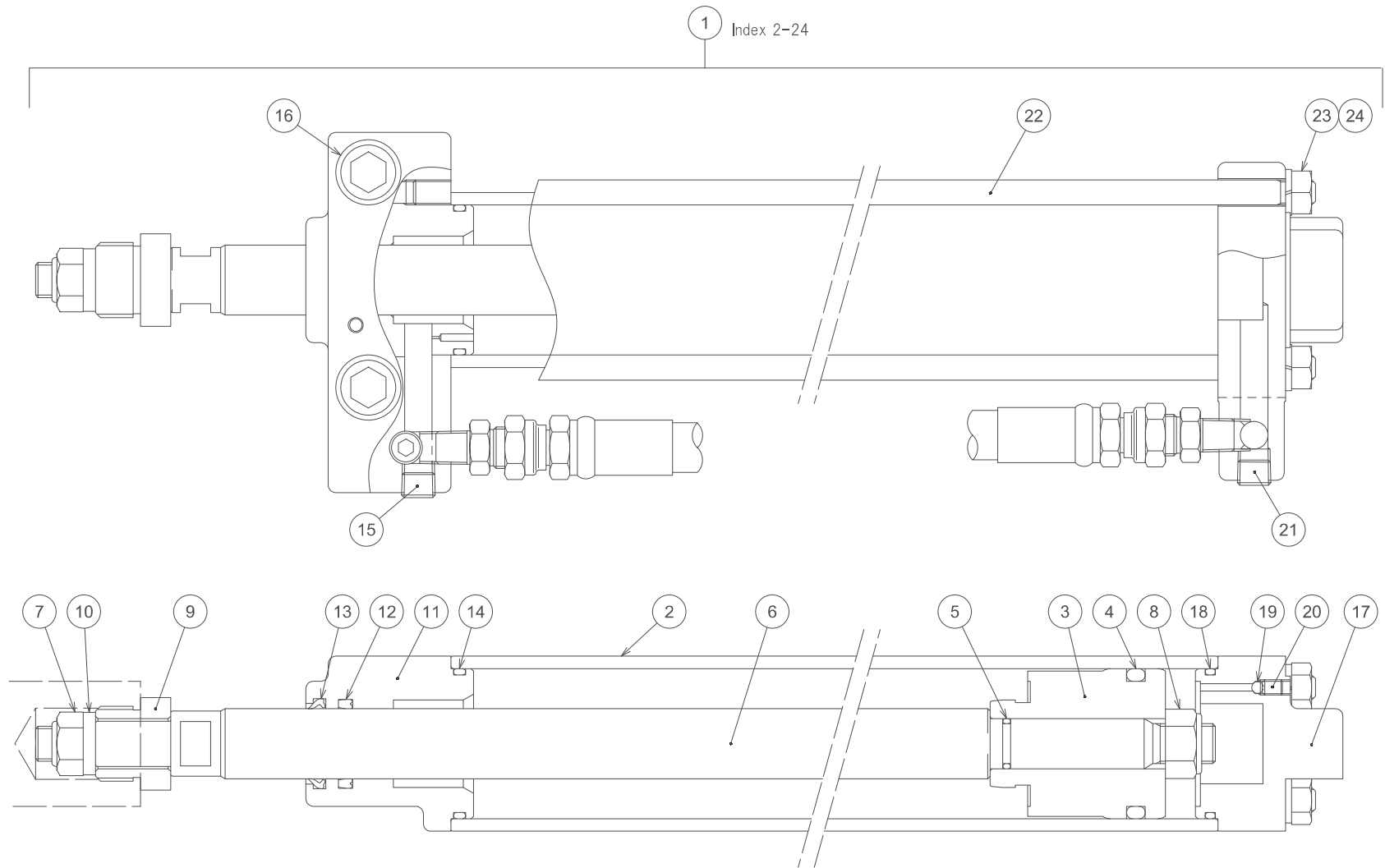

1230338A

Unit No. 54
Feed Cylinder(2)

Index	Code	Parts Name	Drawing No.	Type	Maker	Q'ty	Note
1	10302106	Feed Cylinder EU ASSY	SBS0138---	1230612 A, 1440907 A, 1238501 others		1	with Index 2-24
2	10583694	Cylinder	1230612 A			1	
3	10301253	Piston	1440907 A			1	
4	10207507	O Ring	P590000050	P50A		1	
5	10589448	O Ring	P590000018	P20		1	
6	10301160	Piston Rod	1230973			1	
7	10382418	Locking Nut	P332505023	M14(Type-1)	FUJI SEIMITSU	1	
8	10380665	Locking Nut	P332505026	M16(Type-1)-SK5	FUJI SEIMITSU	1	
9	10376389	Bushing Nut	1108576 C			1	
10	10376756	Washer	1108577			1	
11	10378383	Cylinder Cap F	1238501			1	
12	10317519	Wiper Ring	P590312003	DKI-28	NOK	1	
13	10333005	Piston Packing	P590403021	SKY-28	SAKAGAMI	1	
14	10001116	O Ring	P590010007	G55		1	
15	10300171	Plug for Piping	P580208021	PT-1/4		2	
16	10583160	Reamer Bolt	1230007 B			2	
17	10378384	Cylinder Cap R	1238502			1	
18	10001116	O Ring	P590010007	G55		1	
19	10332944	Steel Ball (for Bearing)	P406000002	3/16	JIS	1	

Unit No. 54
Feed Cylinder(2)

Index	Code	Parts Name	Drawing No.	Type	Maker	Q'ty	Note
20	10326708	Socket Set Screw	P330570062	M6X8(Dog-end)	JIS	1	
21	10300171	Plug for Piping	P580208021	PT-1/4		2	
22	10583697	Tie Rod	1230614 A			4	
23	10427991	Nut	P332000006	M10	JIS	4	
24	10001520	Spring Washer	P336050007	10	JIS	4	

Unit No. 55
Vertical Roller

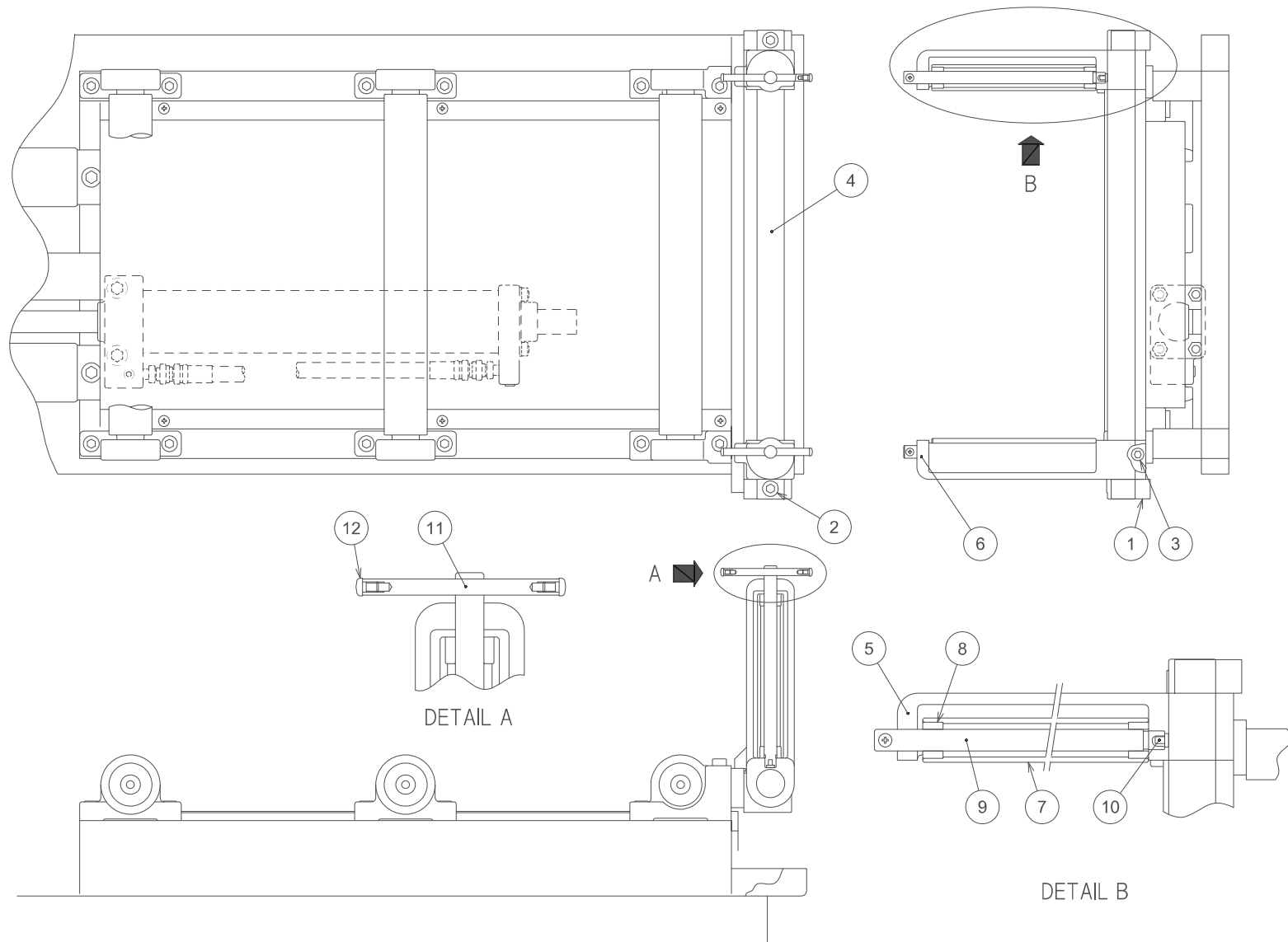

1238571--A

Unit No. 55
Vertical Roller

Index	Code	Parts Name	Drawing No.	Type	Maker	Q'ty	Note
1	10378565	Support Bracket	1238587			1	
2	10322203	Hex Socket Cap Screw	P330250005	M12X30		2	
3	10341713	Hex Socket Cap Screw	P330240006	M10X20		4	
4	10378564	Guide Bar	1238586			1	
5	10380765	Roller Bracket Left	1238583 A			1	
6	10380764	Roller Bracket Right	1238582 A			1	
7	10378563	Roller	1238585			2	
8	10301139	Shaft Support	0603310--A			4	
9	10378562	Vertical Roller Set Bar	1238584			2	
10	10301140	Lock Piece	0603312--A			2	
11	10301141	Handle	0603314--C			2	
12	10325312	Pan Head Screw	P334100054	M6X10	JIS	4	

Unit No. 56
Rear Vise(1)-1/3

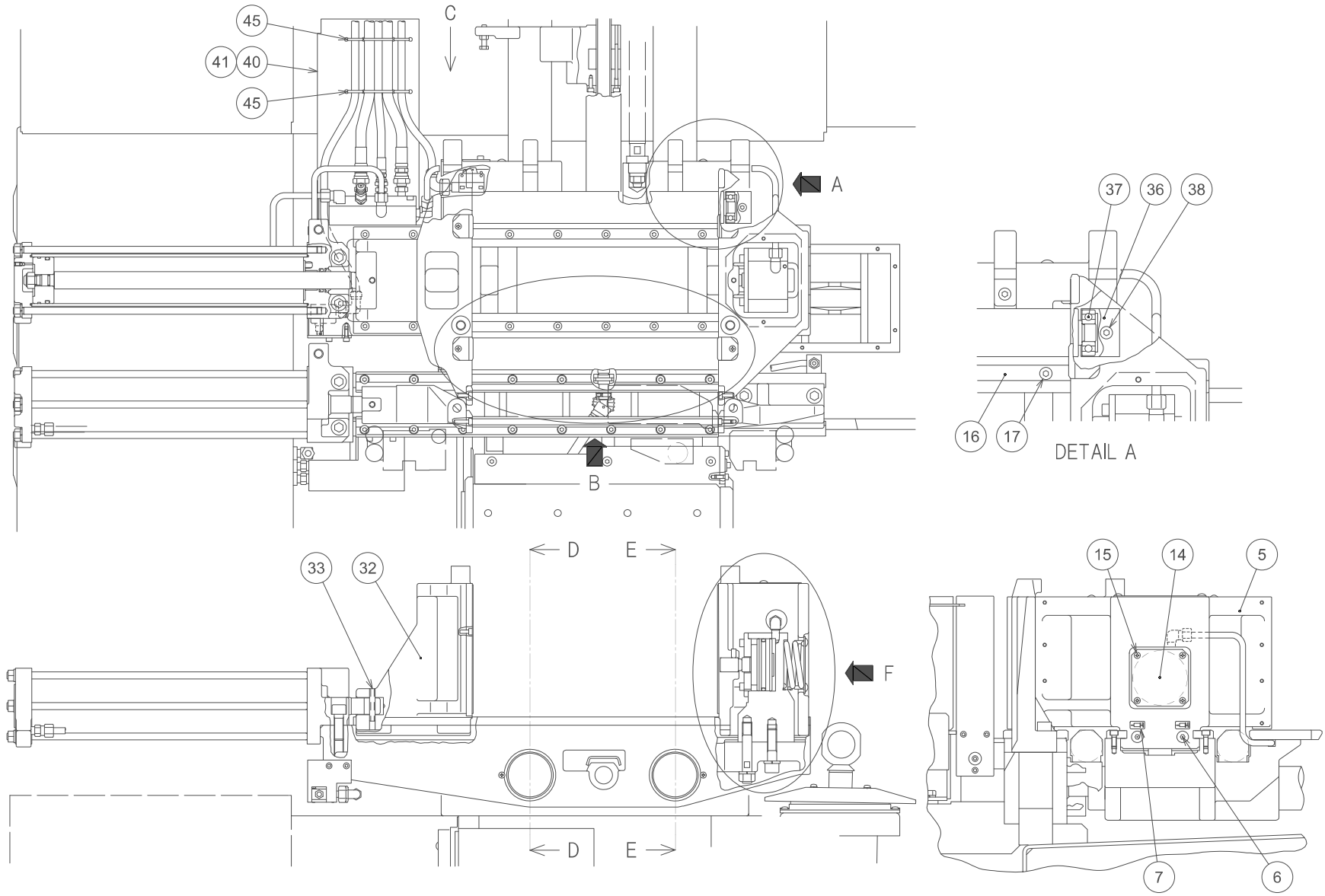

1278801--A

Unit No. 56
Rear Vise(1)-2/3

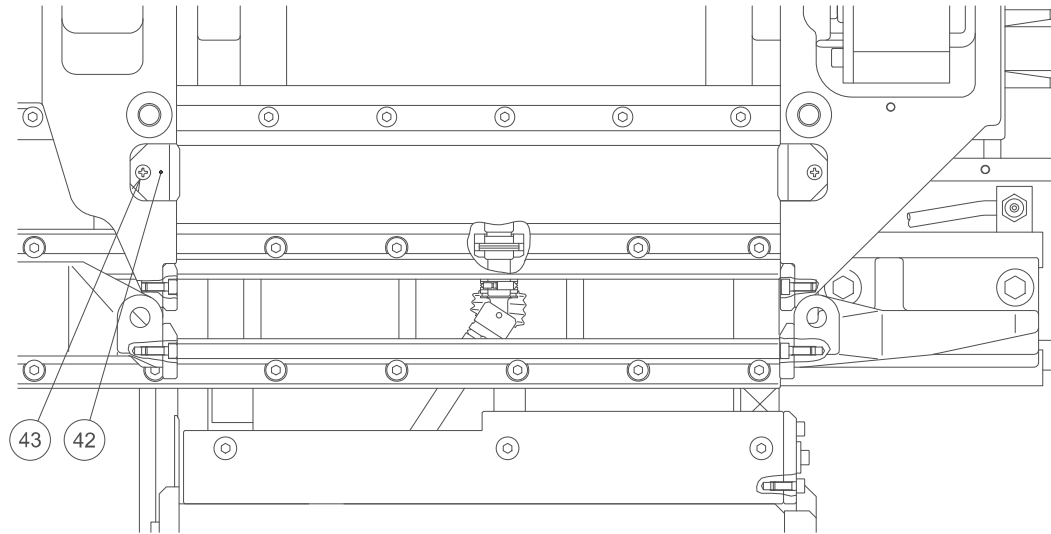

DETAIL B

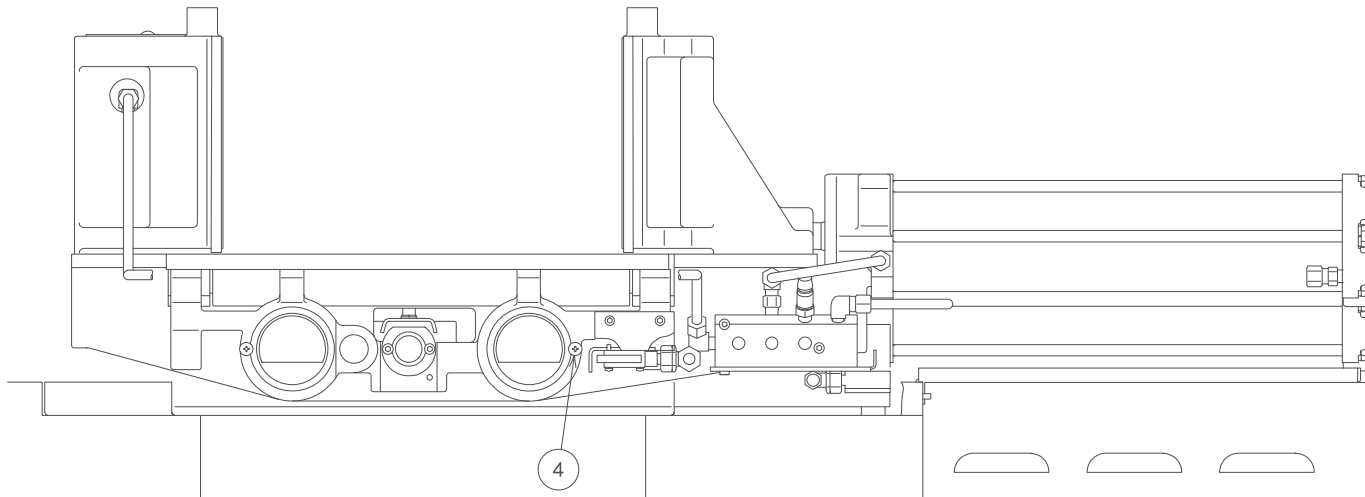

VIEW C

1278801--A

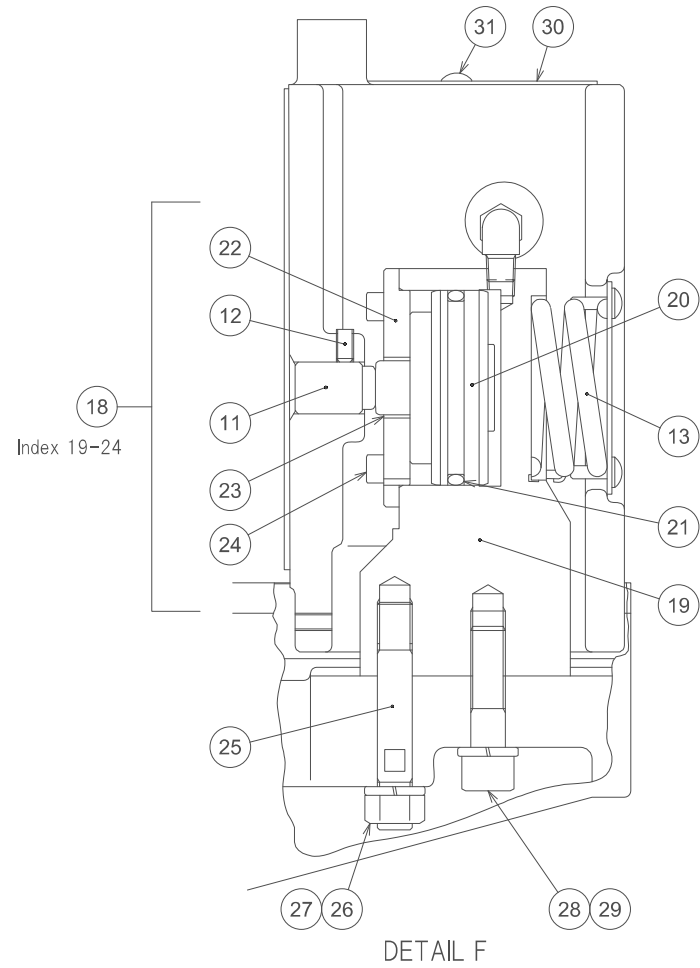
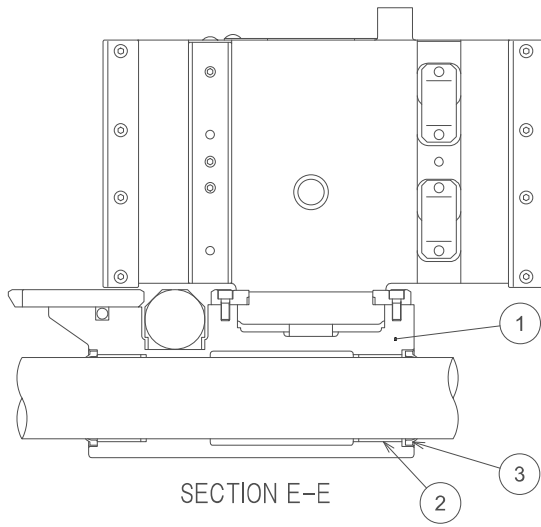
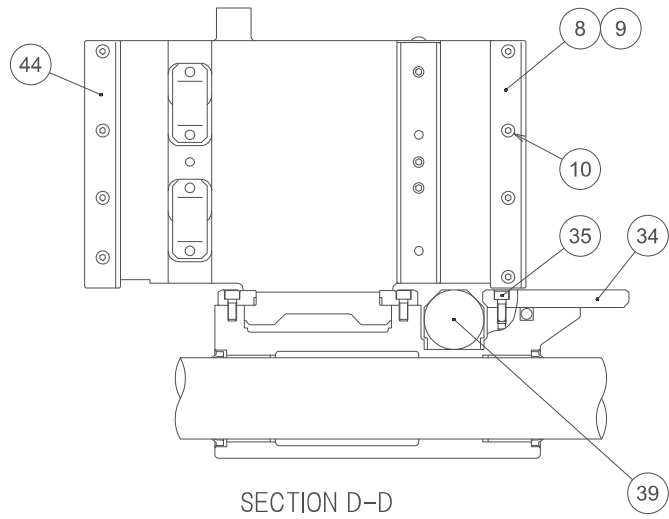

Unit No. 56
Rear Vise(1)

Index	Code	Parts Name	Drawing No.	Type	Maker	Q'ty	Note
1	10583698	Rear Vise Bed	1238492 E			1	
2	10301324	Plain Bearing	RB0054082-	SF-1 7540	KBT	4	
3	10375805	Wiper Ring	P590313017	SCB-75	SAKAGAMI	4	
4	10340019	Truss Head Screw	P334130012	M6X12	JIS	4	
5	10380650	Rear Vise Jaw (Stationary)	1238473			1	
6	10419913	Grease Nipple	P560600002	A-MT6X1	JIS	2	
7	10323010	Name Plate	0852250			2	
8	10378365	Rear Vise Plate	1238687 A			3	
9	10378369	Stationary Vise Shim	1238484			1	
10	10312831	Hex Socket Cap Screw	P330220006	M6X15		16	
11	10567020	Pushing Screw	1230669 A			1	
12	10329311	Socket Set Screw	P330590058	M8X15(Dimple Type)	MOURI	1	
13	10301157	Spring	1230677 A			1	
14	10332711	Spring Retainer	1230670			1	
15	10322133	Truss Head Screw	P334130014	M6X20	JIS	4	
16	10301173	Slide Plate	1238493 B			2	
17	10322202	Hex Socket Cap Screw	P330230006	M8X20		20	
18	10302103	Rear Vise Cylinder (Stationary Jaw Side) ASSY	SBS0135---	1230673, 1230674, 1230675 A others		1	with Index 19-24
19	10316910	Cylinder	1230673			1	

Unit No. 56
Rear Vise(1)

Index	Code	Parts Name	Drawing No.	Type	Maker	Q'ty	Note
20	10316917	Stationary Vise Piston	1230674			1	
21	10316808	O Ring	P590000064	P80		1	
22	10332607	Cylinder Cap	1230675 A			1	
23	10581365	Plain Bearing	P407003207	DUB2512	DAIDO METAL	1	
24	10322202	Hex Socket Cap Screw	P330230006	M8X20		4	
25	10313646	Reamer Bolt	1230676			1	
26	10322218	Spring Washer	P336050010	16	JIS	1	
27	10421756	Nut	P332000009	M16	JIS	1	
28	10332954	Hex Socket Cap Screw	P330260036	M16X60		1	
29	10322153	Conical Spring Washer	P336165005	CDW-16H	HHK	1	
30	10378370	Cover	1238497			1	
31	10340019	Truss Head Screw	P334130012	M6X12	JIS	2	
32	10583699	Rear Vise Movable Jaw	1238474 B			1	
33	10322112	Spring Pin	P337030096	10X60AW	OHKITA	1	
34	10583701	Auxiliary Plate	1230659 A			1	
35	10322202	Hex Socket Cap Screw	P330230006	M8X20		2	
36	10376204	Roller Bracket	1233020 B			2	
37	10555909	Deep Groove Ball Bearing	P400017017	6304DDU	NSK	2	
38	10342326	Hex Socket Cap Screw	P330230012	M8X50		2	

Unit No. 56
Rear Vise(1)

Index	Code	Parts Name	Drawing No.	Type	Maker	Q'ty	Note
39	10378048	Roller	1238488 A			1	
40	10583702	Plate	1230679 B			1	
41	10323201	Hex Socket Cap Screw	P330220004	M6X12	JIS	2	
42	10380642	Vise Plate Cover	1280733 A			4	
43	10332134	Truss Head Screw	P334130010	M6X8	JIS	4	
44	10419350	Rear Vise Plate 2	1238886			1	
45	10375463	Cable Band	P381058035	SKB-2M	KITAGAWA	12	

Unit No. 57

Rear Vise(2)-1/3 <Rear Vise for EU Spec>

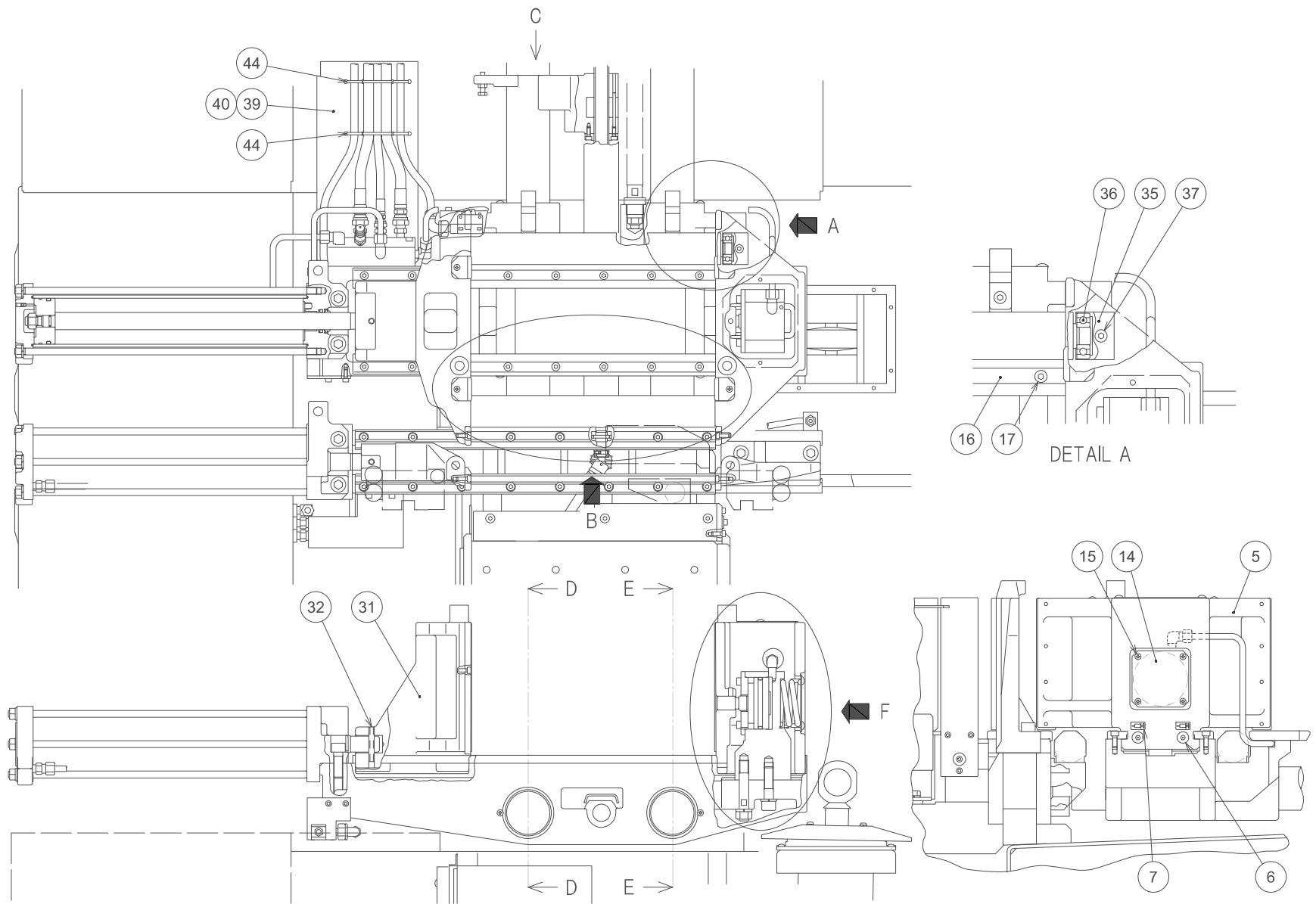

RB02618--A

Unit No. 57

Rear Vise(2)-2/3 <Rear Vise for EU Spec>

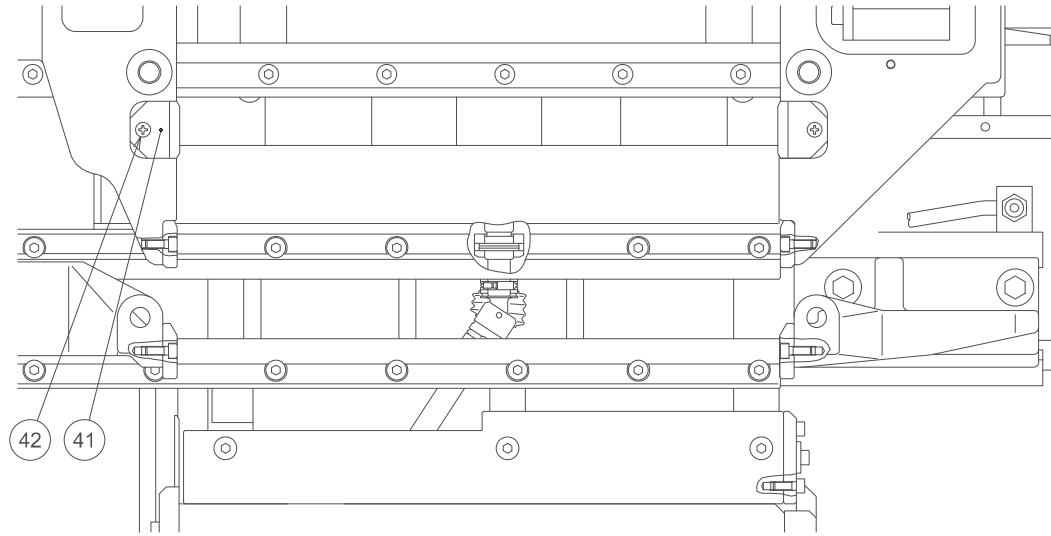

DETAIL B

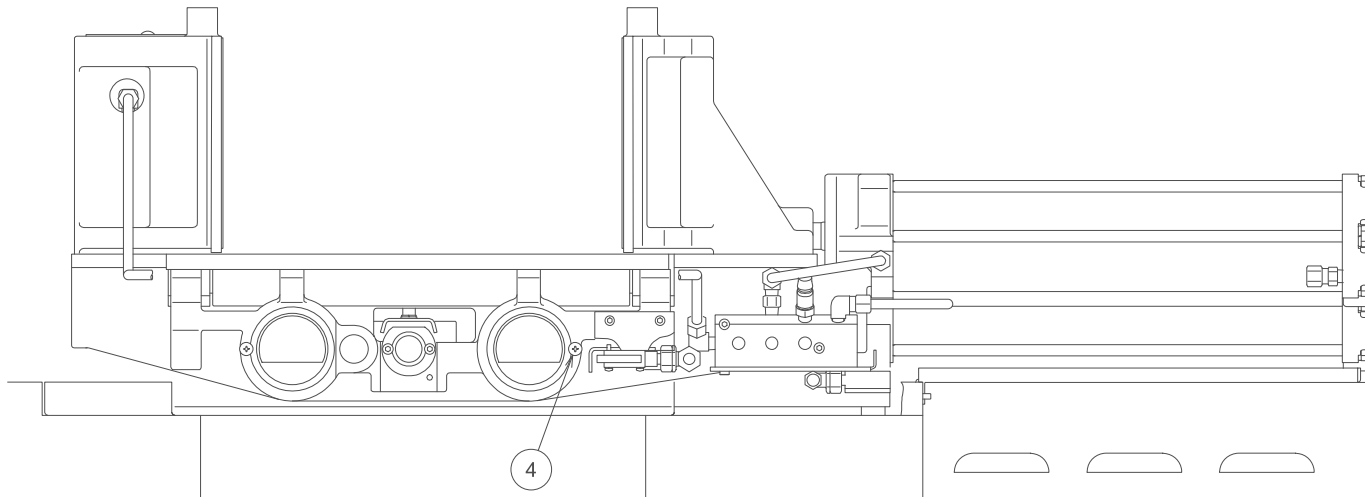

VIEW C

RB02618--A

Unit No. 57

Rear Vise(2)-3/3 <Rear Vise for EU Spec>

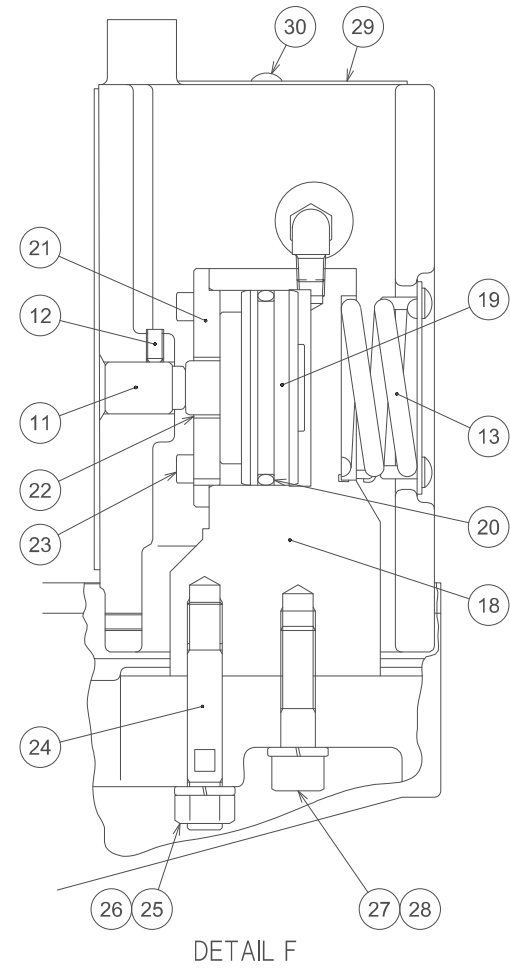
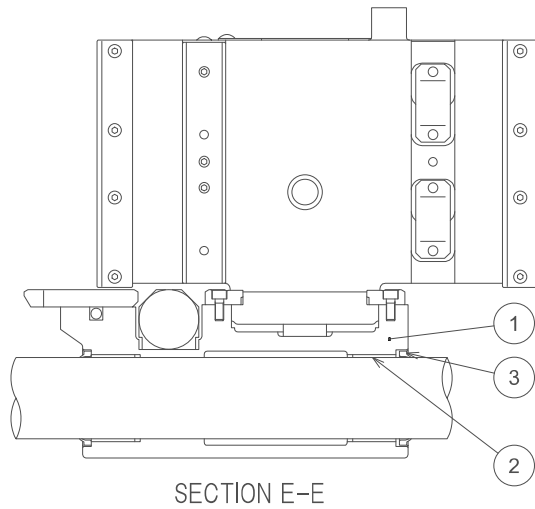
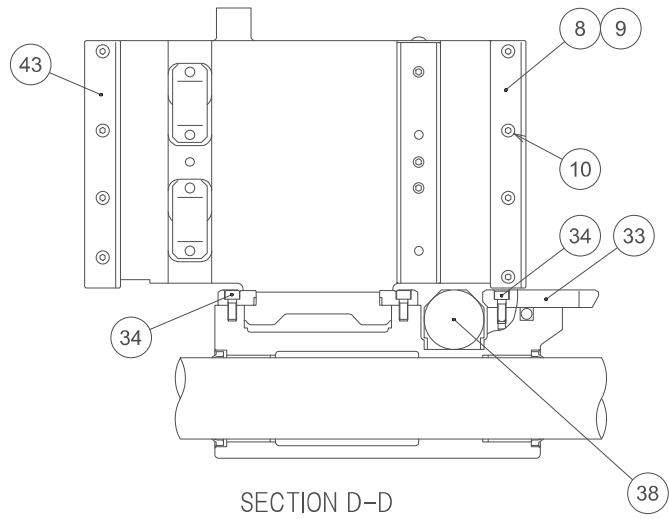

RB02618--A

Unit No. 57
Rear Vise(2)

Index	Code	Parts Name	Drawing No.	Type	Maker	Q'ty	Note
1	10583698	Rear Vise Bed	1238492 E			1	
2	10301324	Plain Bearing	RB0054082-	SF-1 7540	KBT	4	
3	10375805	Wiper Ring	P590313017	SCB-75	SAKAGAMI	4	
4	10340019	Truss Head Screw	P334130012	M6X12	JIS	4	
5	10380650	Rear Vise Jaw (Stationary)	1238473			1	
6	10419913	Grease Nipple	P560600002	A-MT6X1	JIS	2	
7	10323010	Name Plate	0852250			2	
8	10378365	Rear Vise Plate	1238687 A			3	
9	10378369	Stationary Vise Shim	1238484			1	
10	10312831	Hex Socket Cap Screw	P330220006	M6X15		16	
11	10567020	Pushing Screw	1230669 A			1	
12	10329311	Socket Set Screw	P330590058	M8X15(Dimple Type)	MOURI	1	
13	10301157	Spring	1230677 A			1	
14	10332711	Spring Retainer	1230670			1	
15	10322133	Truss Head Screw	P334130014	M6X20	JIS	4	
16	10301173	Slide Plate	1238493 B			2	
17	10322202	Hex Socket Cap Screw	P330230006	M8X20		20	
18	10316910	Cylinder	1230673			1	
19	10316917	Stationary Vise Piston	1230674			1	

Unit No. 57
Rear Vise(2)

Index	Code	Parts Name	Drawing No.	Type	Maker	Q'ty	Note
20	10316808	O Ring	P590000064	P80		1	
21	10332607	Cylinder Cap	1230675 A			1	
22	10581365	Plain Bearing	P407003207	DUB2512	DAIDO METAL	1	
23	10322202	Hex Socket Cap Screw	P330230006	M8X20		4	
24	10313646	Reamer Bolt	1230676			1	
25	10322218	Spring Washer	P336050010	16	JIS	1	
26	10421756	Nut	P332000009	M16	JIS	1	
27	10332954	Hex Socket Cap Screw	P330260036	M16X60		1	
28	10322153	Conical Spring Washer	P336165005	CDW-16H	HHK	1	
29	10378370	Cover	1238497			1	
30	10340019	Truss Head Screw	P334130012	M6X12	JIS	2	
31	10583699	Rear Vise Movable Jaw	1238474 B			1	
32	10322112	Spring Pin	P337030096	10X60AW	OHKITA	1	
33	10301158	Auxiliary Plate	1230971			1	
34	10322202	Hex Socket Cap Screw	P330230006	M8X20		2	
35	10376204	Roller Bracket	1233020 B			2	
36	10555909	Deep Groove Ball Bearing	P400017017	6304DDU	NSK	2	
37	10342326	Hex Socket Cap Screw	P330230012	M8X50		2	
38	10378048	Roller	1238488 A			1	

Unit No. 57
Rear Vise(2)

Index	Code	Parts Name	Drawing No.	Type	Maker	Q'ty	Note
39	10583702	Plate	1230679 B			1	
40	10323201	Hex Socket Cap Screw	P330220004	M6X12	JIS	2	
41	10380642	Vise Plate Cover	1280733 A			4	
42	10332134	Truss Head Screw	P334130010	M6X8	JIS	4	
43	10419350	Rear Vise Plate 2	1238886			1	
44	10375463	Cable Band	P381058035	SKB-2M	KITAGAWA	12	

Unit No. 58

Rear Vise(3) <Rear Vise Guard for EU Spec>

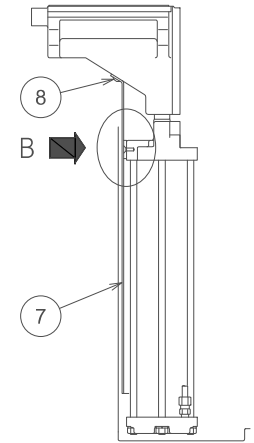
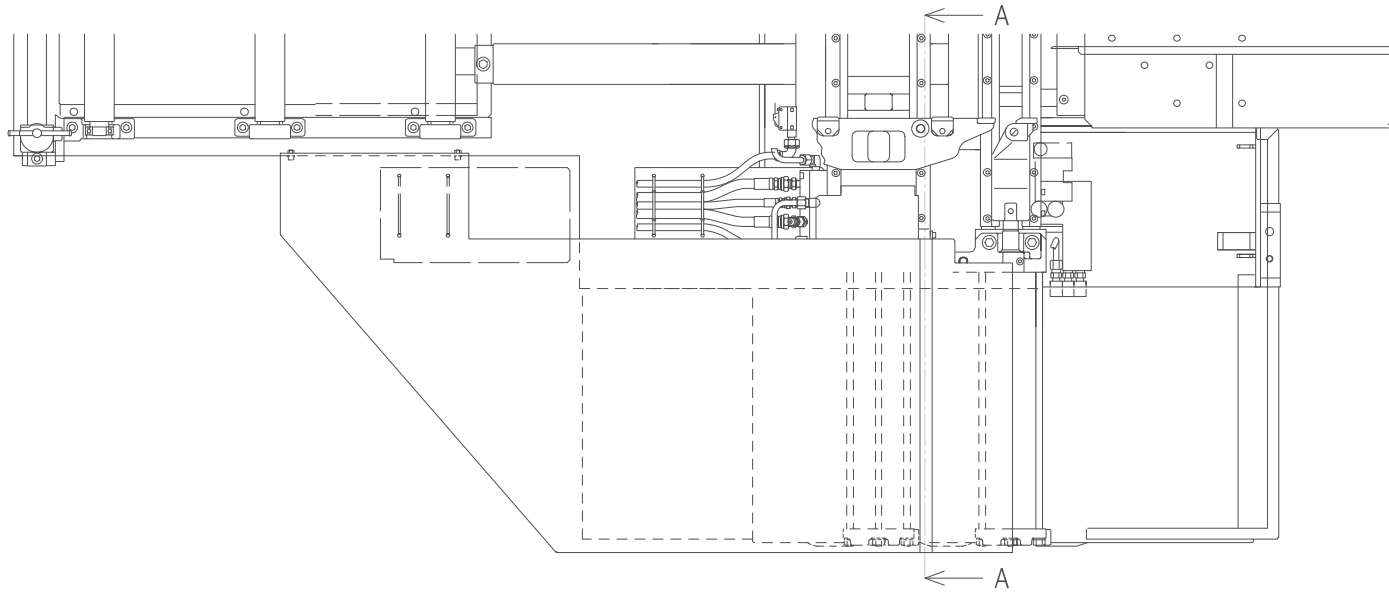

SECTION A-A

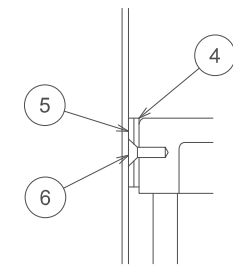
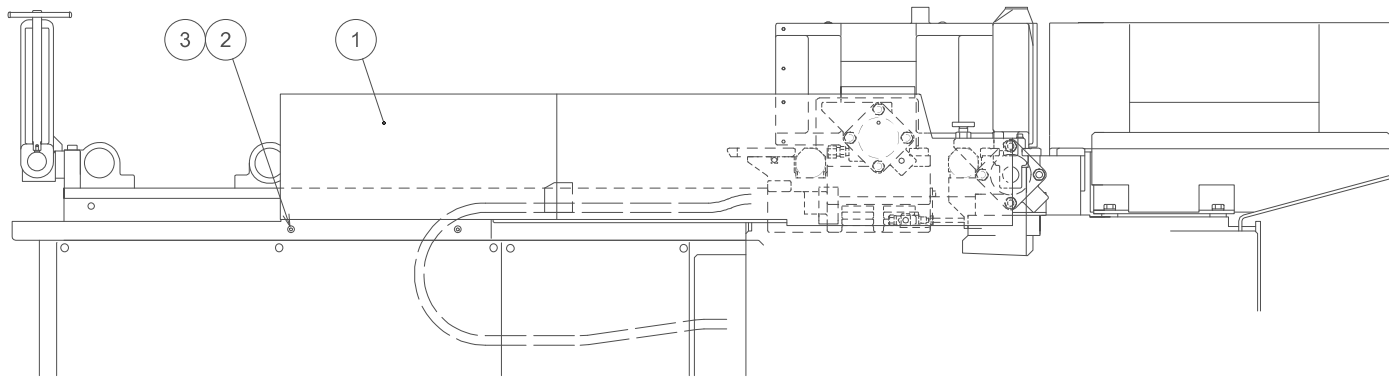

DETAIL B

1230341A

Unit No. 58
Rear Vise(3)

Index	Code	Parts Name	Drawing No.	Type	Maker	Q'ty	Note
1	10301162	Cylinder Cover	1230975 A			1	
2	10323201	Hex Socket Cap Screw	P330220004	M6X12	JIS	3	
3	10321922	Washer	P336000005	6(Normal)	JIS	3	
4	10301260	Pusher	1440952			1	
5	10301261	Guide Plate	1440953			2	
6	10328361	Flat Head Bolt	P334520016	M6X12	NISSAN NEJI	2	
7	10301262	Rear Vise Cylinder Cover	1440954			1	
8	10385708	Truss Head Screw	P334130011	M6X10	JIS	2	

Unit No. 59

Rear Vise(4) <Uplift Prevention Plate ASSY>

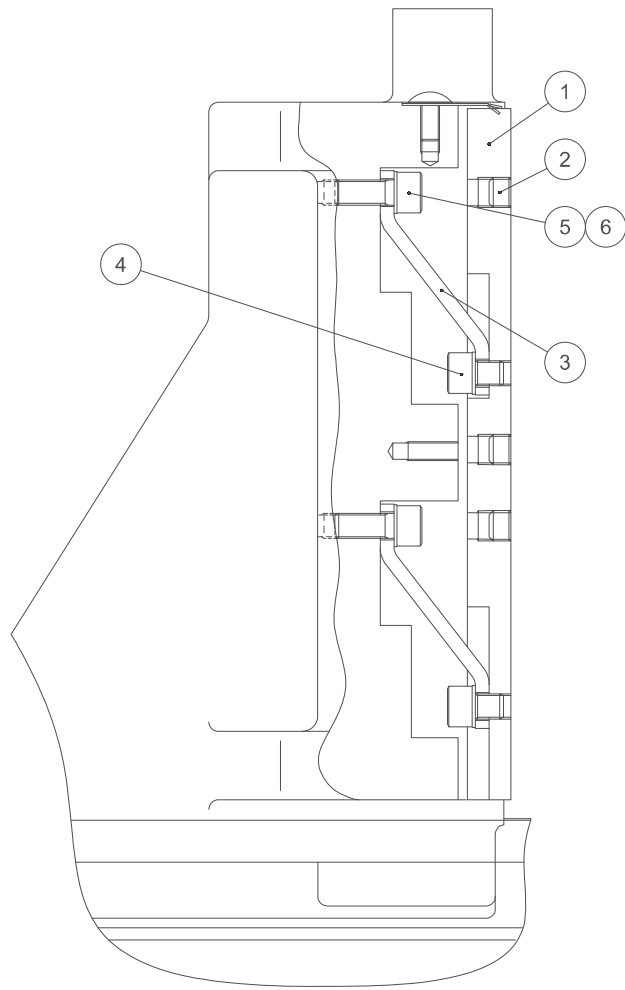

SECTION A-A

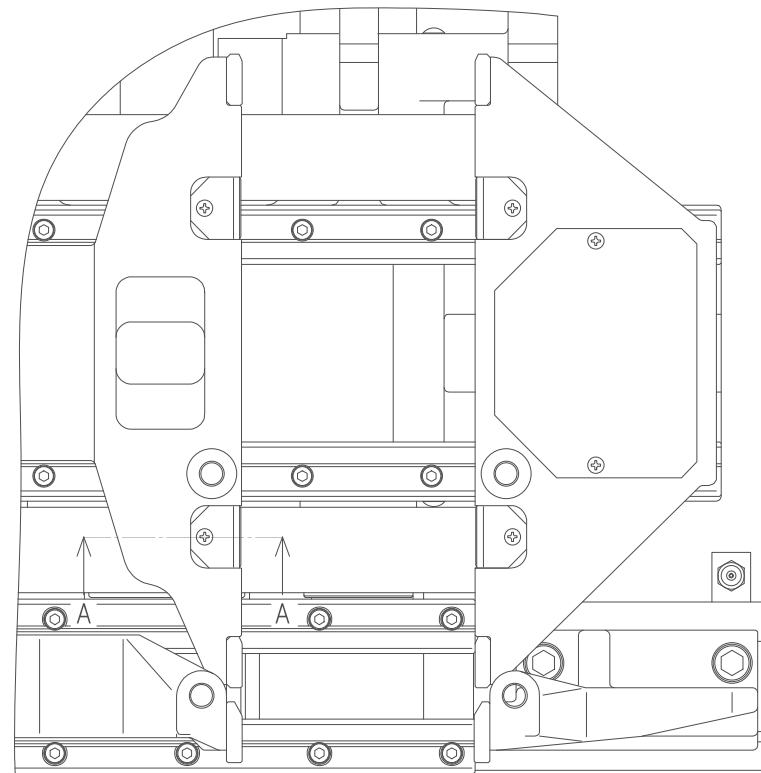

1238677
(1278801--A)

Unit No. 59
Rear Vise(4)

Index	Code	Parts Name	Drawing No.	Type	Maker	Q'ty	Note
1	10332574	Plate	1238685 B			4	
2	10380409	Plug for Piping	P580208022	PT-1/8		12	
3	10313822	Leaf Spring	1280732 A			8	
4	10323206	Hex Socket Cap Screw	P330230002	M8X12	JIS	8	
5	10322202	Hex Socket Cap Screw	P330230006	M8X20		8	
6	10301322	Conical Spring Washer	QZZ036564	H-8		16	

Unit No. 60
Rear Vise(5)-1/2 <Limit Switch>

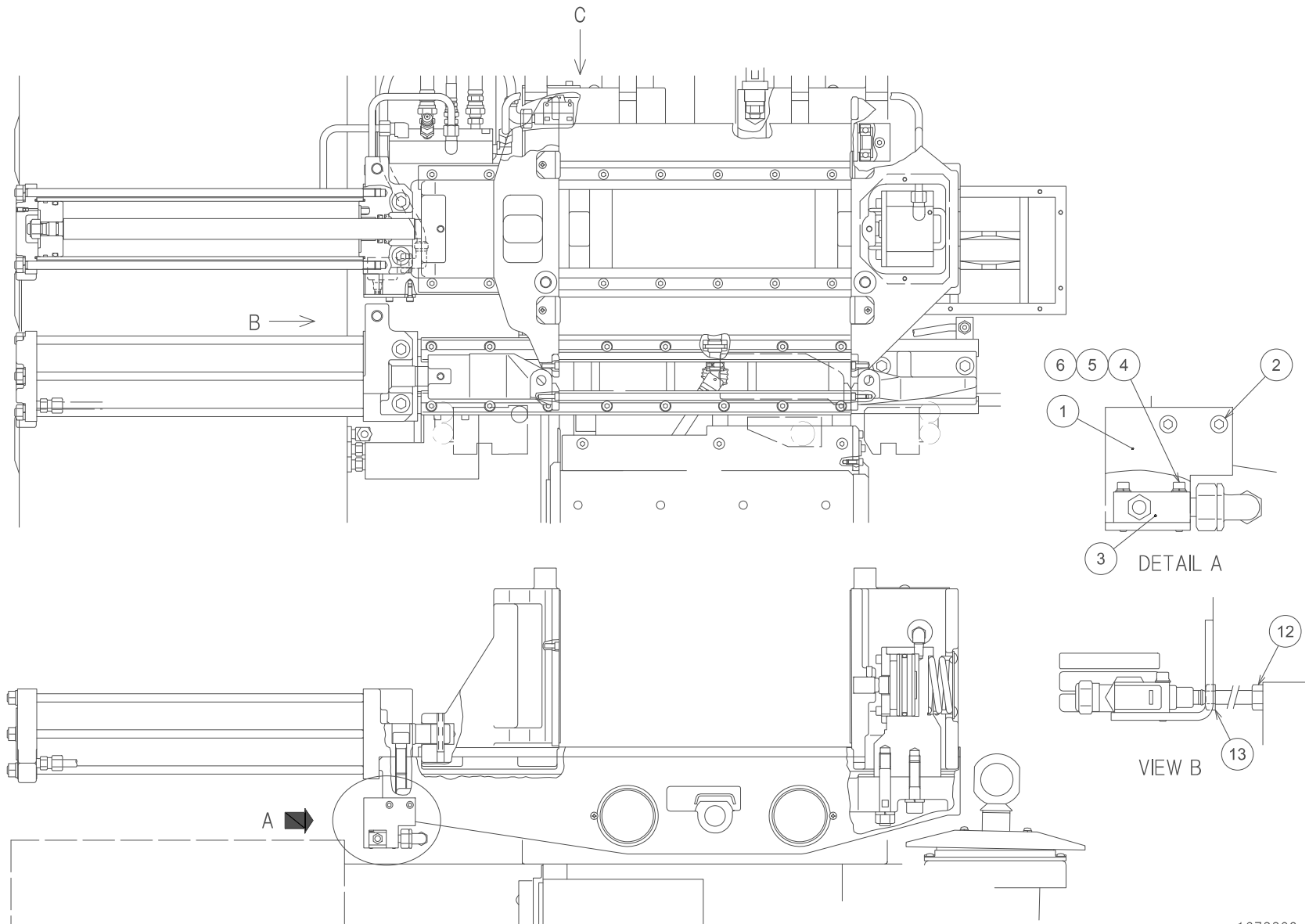

1278809---
(1278801--A)

Unit No. 60
Rear Vise(5)-2/2 <Limit Switch>

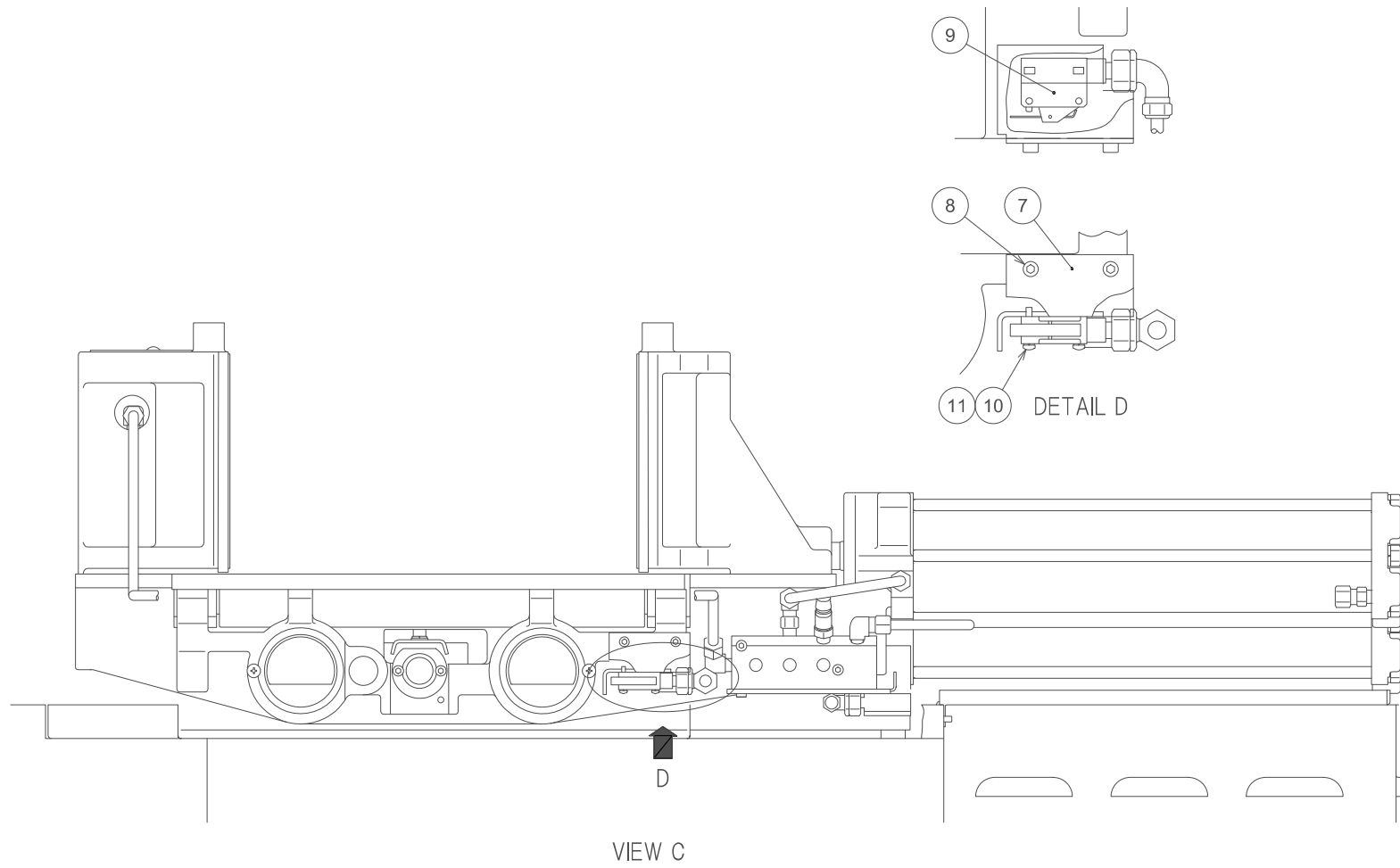

1278809---
(1278801--A)

Unit No. 60
Rear Vise(5)

Index	Code	Parts Name	Drawing No.	Type	Maker	Q'ty	Note
1	10419768	LS Bracket	1238495 B			1	
2	10323204	Hex Socket Cap Screw	P330220007	M6X16	JIS	2	
3	10318839	Limit Switch	P828013017	SL1-S155	YAMATAKE	1	
4	10363419	Hex Socket Cap Screw	P330200022	M4X25		2	
5	10337110	Washer	P336000003	4(Small Round)	JIS	2	
6	10318527	Spring Washer	P336050003	4	JIS	2	
7	10380864	LS Bracket 2	1238887			1	
8	10323204	Hex Socket Cap Screw	P330220007	M6X16	JIS	2	
9	10380865	Limit Switch	QZZ040910	SL1-T	YAMATAKE	1	
10	10337028	Pan Head Screw	P334100025	M4X25	JIS	2	
11	10318527	Spring Washer	P336050003	4	JIS	2	
12	10382724	Bolt	P330030014	M8X45(All-thread)	MOURI	1	
13	10589226	Nut	P332000005	M8	JIS	1	

Unit No. 61
Rear Vise(6)-1/2 <EU Specification Machine>

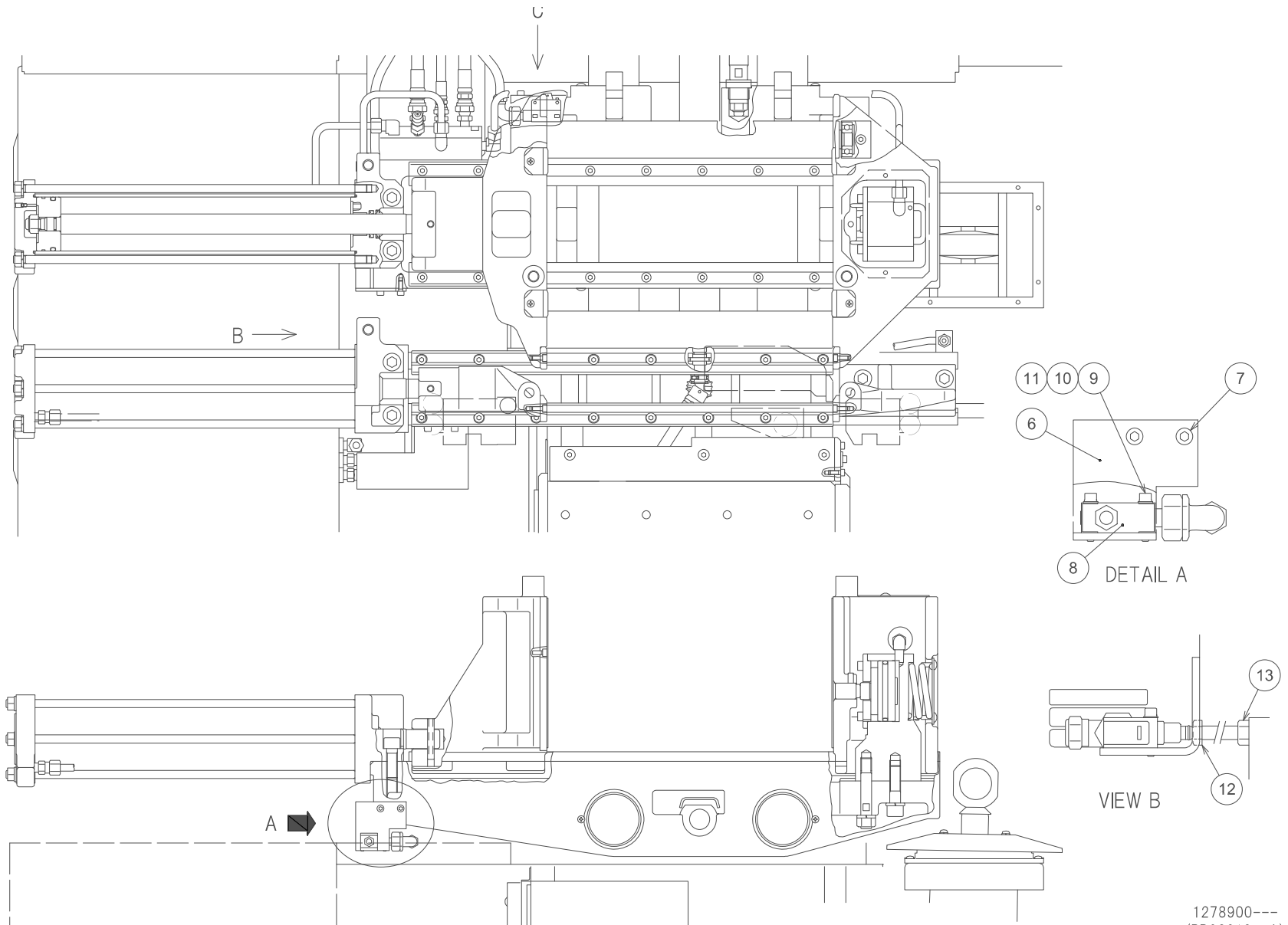

1278900---
(RB02618--A)

Unit No. 61
Rear Vise(6)-2/2 <EU Specification Machine>

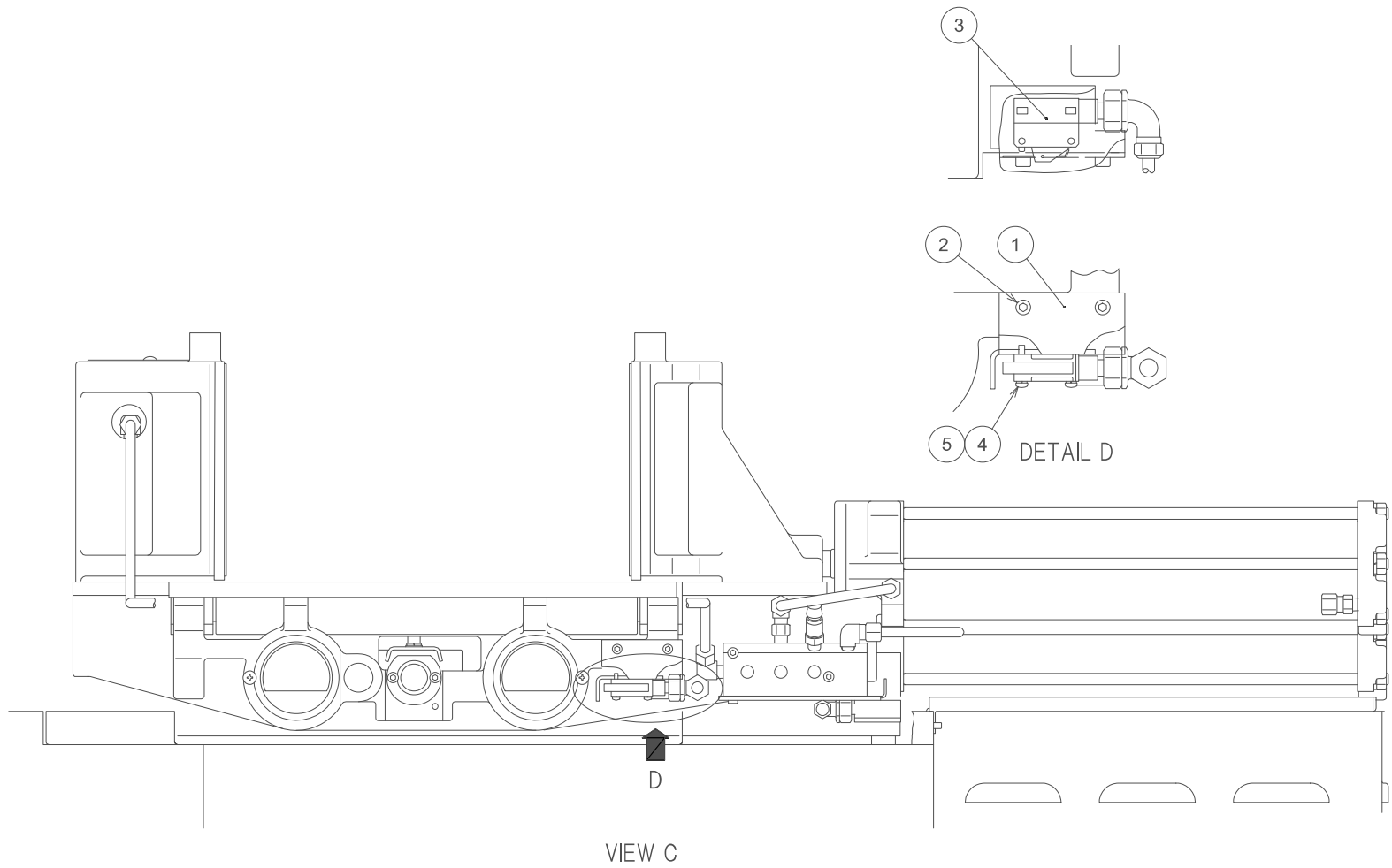

1278900---
(RB02618--A)

Unit No. 61
Rear Vise(6)

Index	Code	Parts Name	Drawing No.	Type	Maker	Q'ty	Note
1	10301545	LS Bracket 2	RB02645---			1	
2	10323204	Hex Socket Cap Screw	P330220007	M6X16	JIS	2	
3	10380865	Limit Switch	QZZ040910	SL1-T	YAMATAKE	1	
4	10337028	Pan Head Screw	P334100025	M4X25	JIS	2	
5	10318527	Spring Washer	P336050003	4	JIS	2	
6	10419768	LS Bracket	1238495 B			1	
7	10323204	Hex Socket Cap Screw	P330220007	M6X16	JIS	2	
8	10318839	Limit Switch	P828013017	SL1-S155	YAMATAKE	1	
9	10363419	Hex Socket Cap Screw	P330200022	M4X25		2	
10	10337110	Washer	P336000003	4(Small Round)	JIS	2	
11	10318527	Spring Washer	P336050003	4	JIS	2	
12	10386758	Bolt	P330030037	M8X80(All-thread)	MOURI	1	
13	10589226	Nut	P332000005	M8	JIS	1	

Unit No. 62
Rear Vise(7) <Patch>

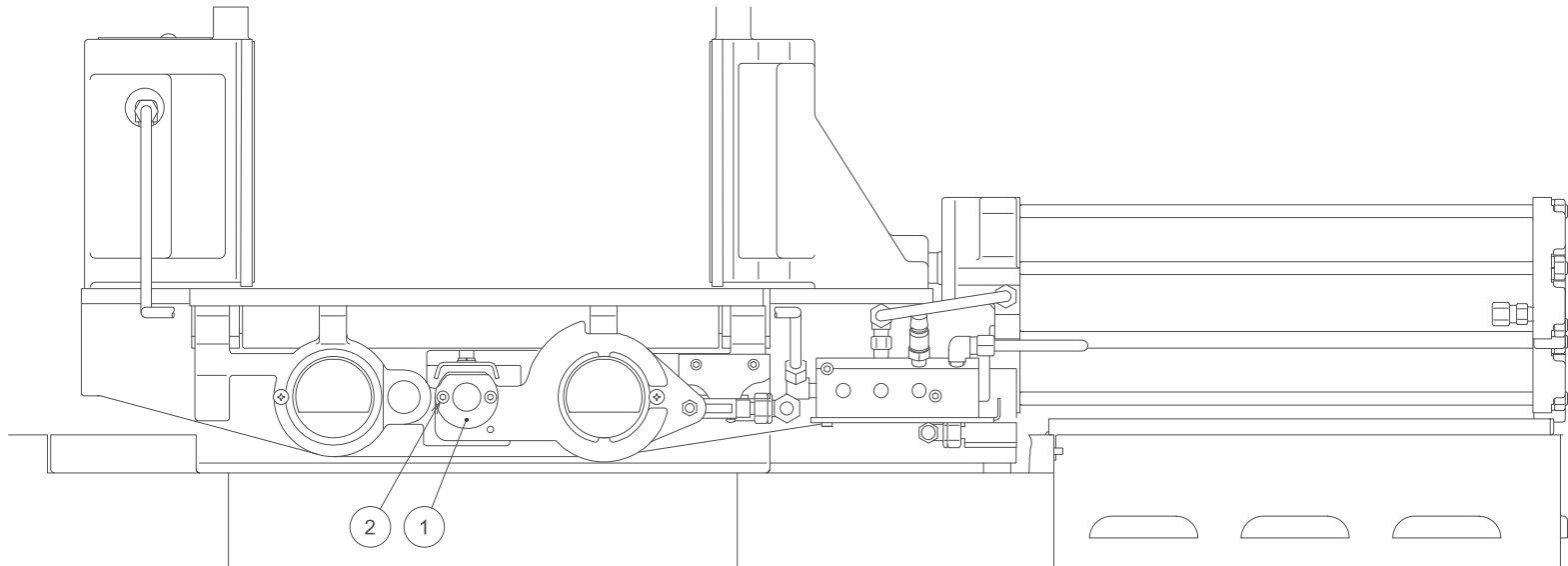
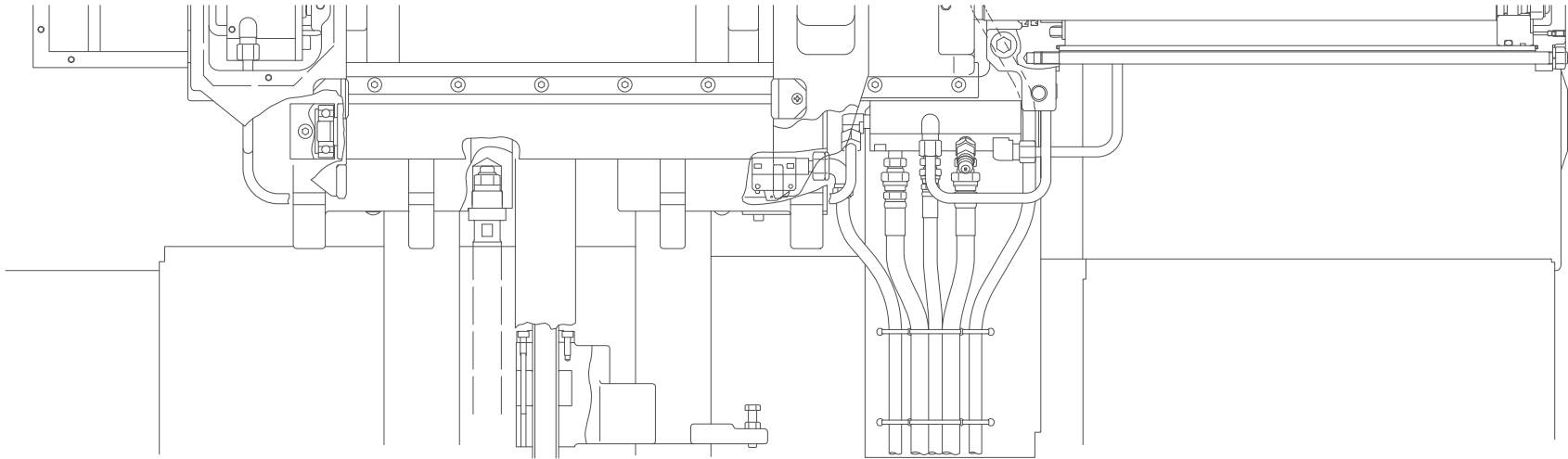

1238469
(1278801--A)

Unit No. 62
Rear Vise(7)

Index	Code	Parts Name	Drawing No.	Type	Maker	Q'ty	Note
1	10331611	Pusher	1230578			1	
2	10323204	Hex Socket Cap Screw	P330220007	M6X16	JIS	2	

Unit No. 63
Rear Vise(8) <Vise Cylinder>

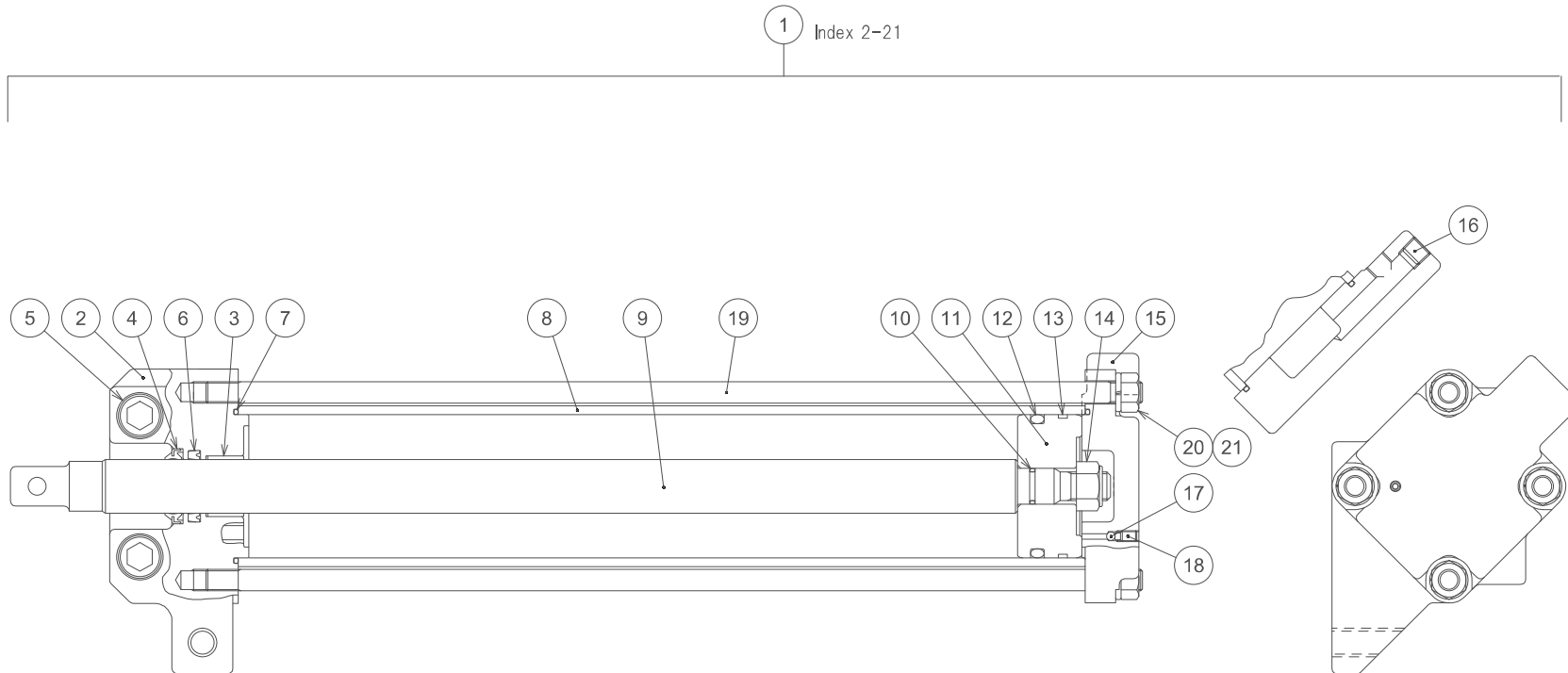

Unit No. 63
Rear Vise(8)

Index	Code	Parts Name	Drawing No.	Type	Maker	Q'ty	Note
1	10302092	Vise Cylinder ASSY	SBS0125---	1238370 A, 1238366, 1238372 others		1	with Index 2-21
2	10301171	Cylinder Cap F	1238370 A			1	
3	10300163	Plain Bearing	P407003176	DUB3020	DAIDO METAL	1	
4	10338202	Wiper Ring	P590313004	SCB-30	SAKAGAMI	1	
5	10332953	Hex Socket Cap Screw	P330260033	M16X45		2	
6	10376483	Piston Packing	P590403023	SKY-30	SAKAGAMI	1	
7	10383406	O Ring	P590012012	1A-G80	NOK	2	
8	10378290	Cylinder	1238366			1	
9	10378291	Piston Rod	1238367 A			1	
10	10589448	O Ring	P590000018	P20		1	
11	10378295	Piston	1238372			1	
12	10001114	O Ring	P590000061	P70		1	
13	10359913	Wearing	P590473021	SWB-80	SAKAGAMI	1	
14	10375004	Locking Nut	P332505010	M16(Type-1)	FUJI SEIMITSU	1	
15	10419313	Cylinder Cap R	1238884 A			1	
16	10300171	Plug for Piping	P580208021	PT-1/4		1	
17	10332944	Steel Ball (for Bearing)	P406000002	3/16	JIS	1	
18	10356511	Socket Set Screw	P330570017	M6X12(Dog-end)	JIS	1	
19	10419314	Tie Rod	1238885			4	

Unit No. 63
Rear Vise(8)

Index	Code	Parts Name	Drawing No.	Type	Maker	Q'ty	Note
20	10589227	Nut	P332000007	M12	JIS	4	
21	10000829	Spring Washer	P336050008	12	JIS	4	

Unit No. 64
 Chip Conveyor(1)-1/2

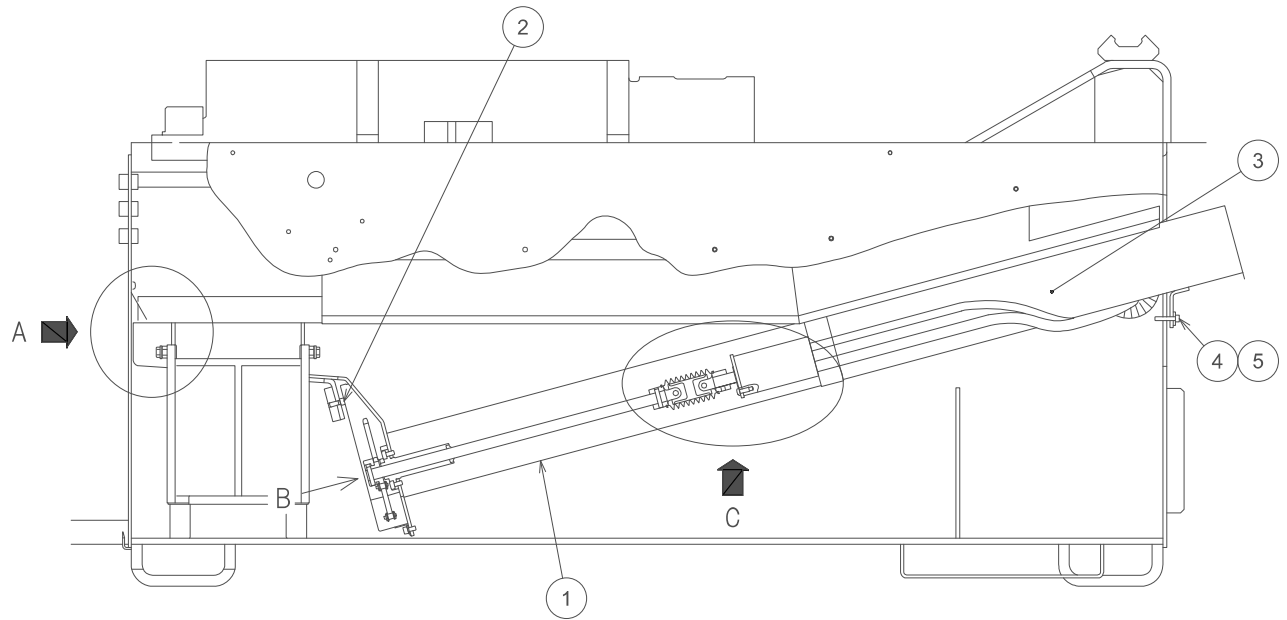
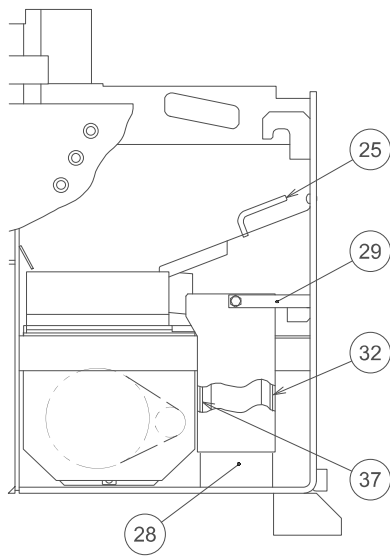
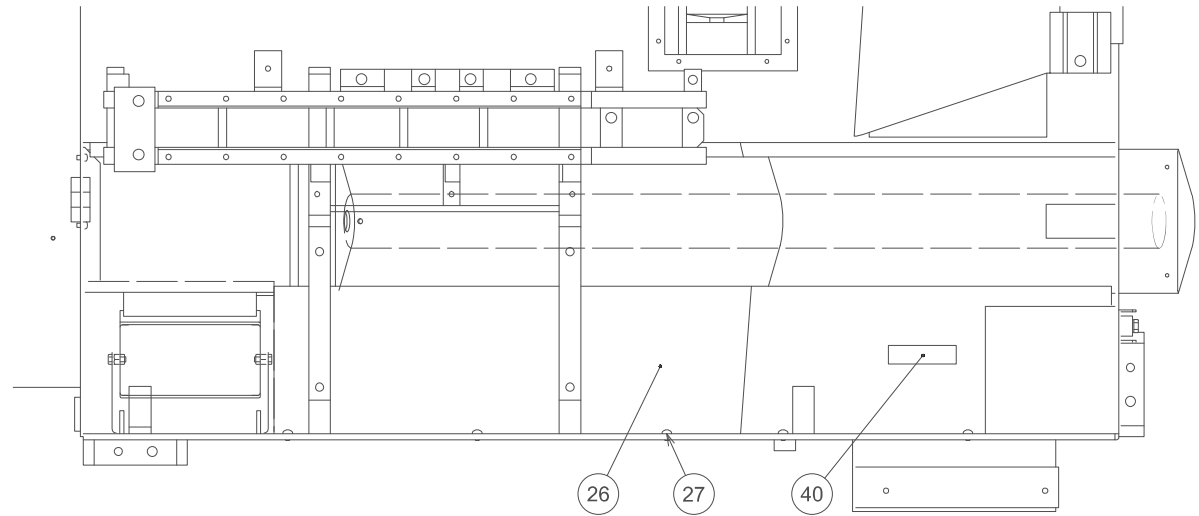
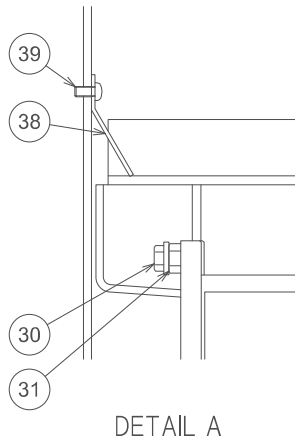

1278805--A

Unit No. 64
Chip Conveyor(1)-2/2

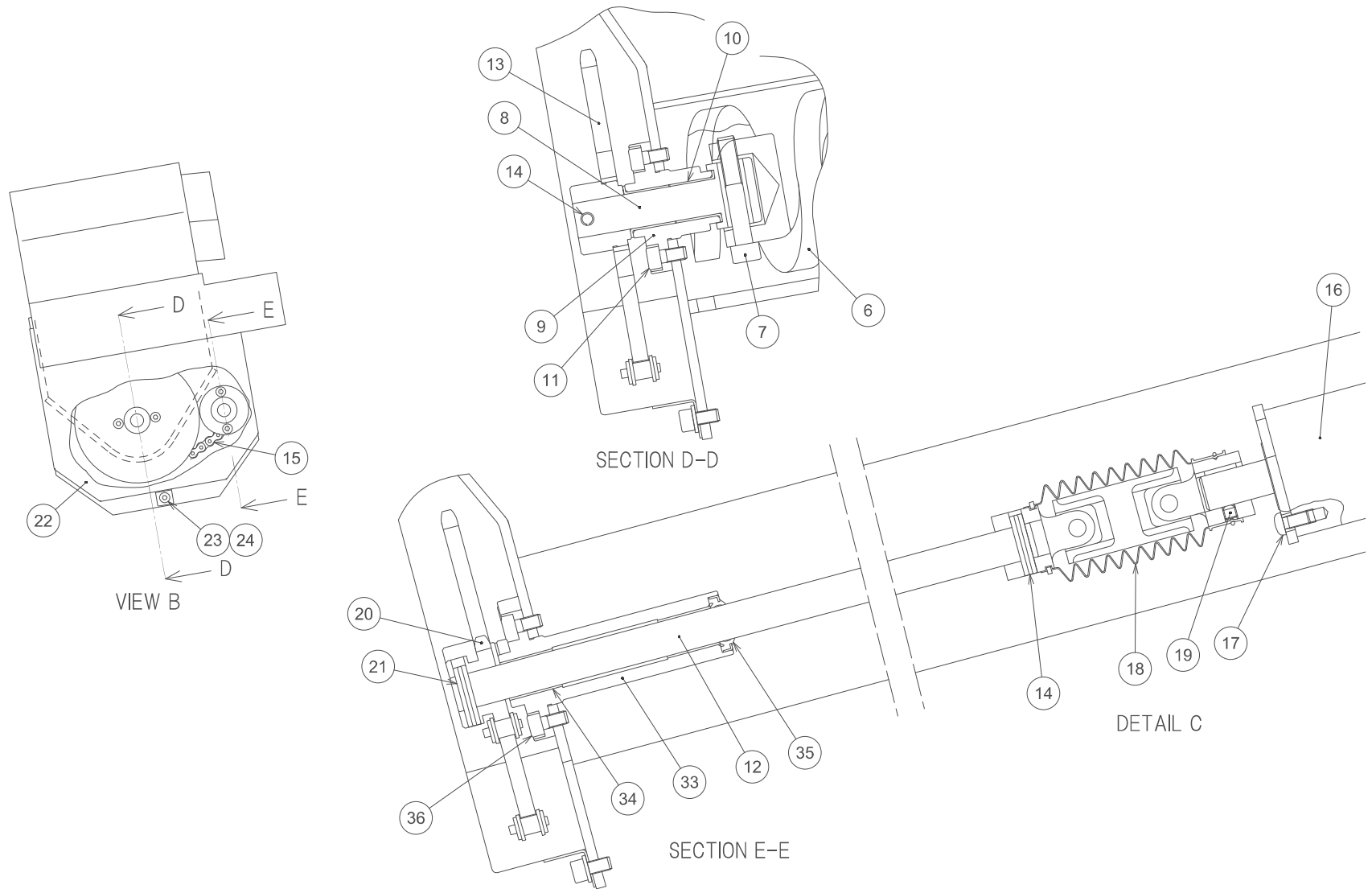

1278805--A

Unit No. 64

Chip Conveyor(1)

Index	Code	Parts Name	Drawing No.	Type	Maker	Q'ty	Note
1	10378636	Spiral Case	1238576 B			1	
2	10380788	Hex Socket Cap Screw	P330220027	M6X16-A2-70-SUS304	MOURI	1	
3	10378637	Spiral Pipe	1238577			1	
4	10376462	Washer	1233546 A			2	
5	10325418	Hex Socket Cap Screw	P330220012	M6X30		2	
6	10378651	Spiral Shaft	7922587	FUT-002	FUTABA HATSUJO	1	
7	10342326	Hex Socket Cap Screw	P330230012	M8X50		1	
8	10331042	Shaft A	1280685 B			1	
9	10331164	Shaft Support A	1280686 B			1	
10	10301296	Plain Bearing	P407013087	K5F1620-24	DAIDO METAL	2	
11	10375811	Hex Socket Cap Screw	P330220028	M6X12-A2-70-SUS304	MOURI	2	
12	10378632	Shaft B	1233544			1	
13	10331149	Sprocket A	1280687 C	RS40-36T,Type-A		1	
14	10328305	Spring Pin	P337030062	6X28AW	JIS	2	
15	10331135	Chain	P410122052	RS40SL-42L(JL)	TSUBAKIMOTO CHAIN	1	
16	10331059	Hydraulic Motor	P541008001	OMM32-151G0003	DANFOSS	1	
17	10328359	Button Head Screw	P334500014	M6X12	JIS	3	
18	10583708	Universal Joint	124469724			1	
19	10312833	Socket Set Screw	P330590017	M6X6(Dimple Type)	JIS	1	

Unit No. 64

Chip Conveyor(1)

Index	Code	Parts Name	Drawing No.	Type	Maker	Q'ty	Note
20	10331150	Sprocket B	1280690 B	RS40-10T,Type-B New		1	
21	10328305	Spring Pin	P337030062	6X28AW	JIS	1	
22	10378634	Chain Cover	1233567			1	
23	10375811	Hex Socket Cap Screw	P330220028	M6X12-A2-70-SUS304	MOURI	1	
24	10321922	Washer	P336000005	6(Normal)	JIS	1	
25	10378638	Chute 1	1238578 A			1	
26	10419539	Chute 2	1244667			1	
27	10340019	Truss Head Screw	P334130012	M6X12	JIS	5	
28	10378640	Chip Box	1238580			1	
29	10331155	Grip	1280695 A			1	
30	10325826	Bolt	P330030006	M8X20		2	
31	10589226	Nut	P332000005	M8	JIS	2	
32	10331032	Screen	1280696 A			1	
33	10331165	Shaft Support B	1280689 C			1	
34	10301295	Plain Bearing	P407003300	K5B1625	DAIDO METAL	2	
35	10331236	Wiper Ring	P590313002	SCB-16	SAKAGAMI	1	
36	10375811	Hex Socket Cap Screw	P330220028	M6X12-A2-70-SUS304	MOURI	2	
37	10378635	Screen A	1233569			1	
38	10419352	Side Cover	1238590 B			1	

Unit No. 64

Chip Conveyor(1)

Index	Code	Parts Name	Drawing No.	Type	Maker	Q'ty	Note
39	10340019	Truss Head Screw	P334130012	M6X12	JIS	2	
40	10300875	Sticker	RB00869--A			1	

Unit No. 65
Chip Conveyor(2) <EU Specification Machine>

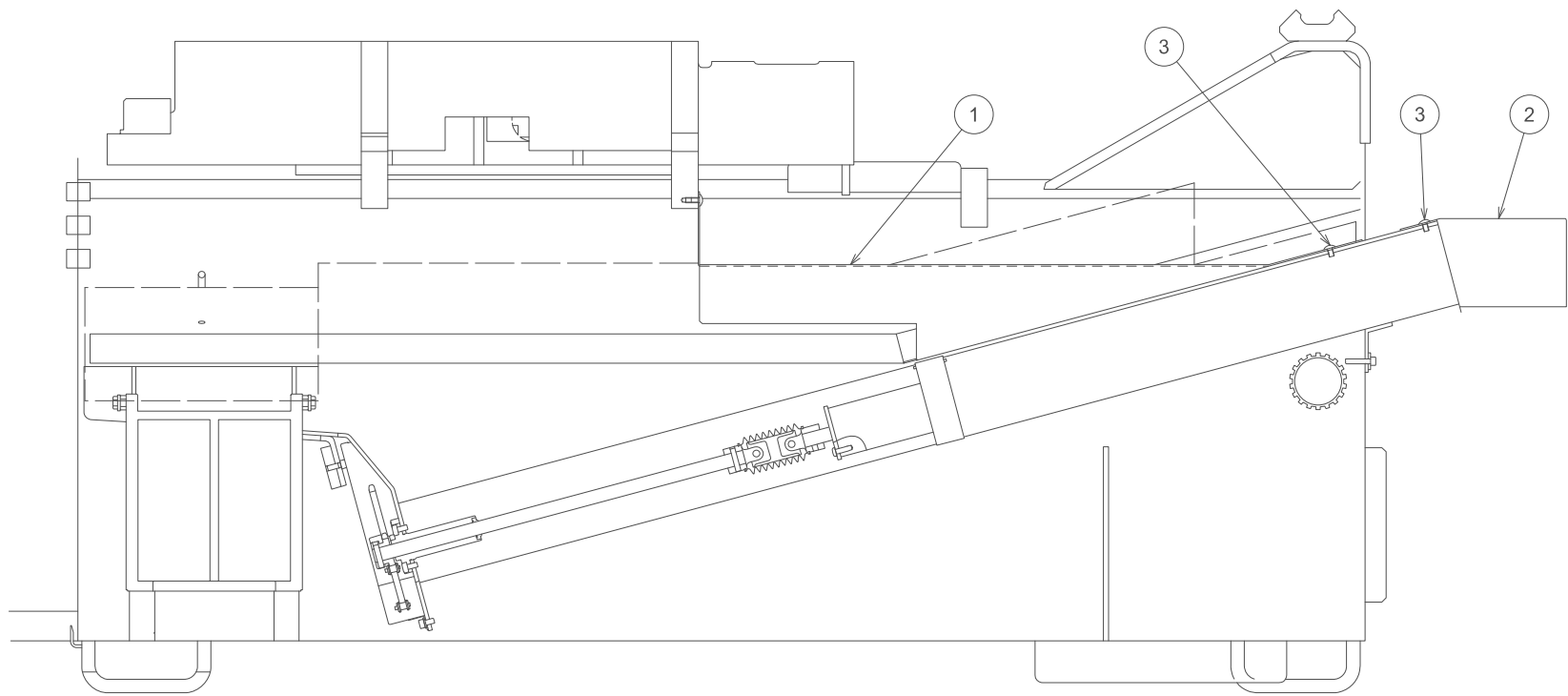

1440909B

Unit No. 65
Chip Conveyor(2)

Index	Code	Parts Name	Drawing No.	Type	Maker	Q'ty	Note
1	10301255	Spiral Case Cover	1440910 A			1	
2	10420412	Cover	1440911			1	
3	10385708	Truss Head Screw	P334130011	M6X10	JIS	4	

Unit No. 66
Work Light

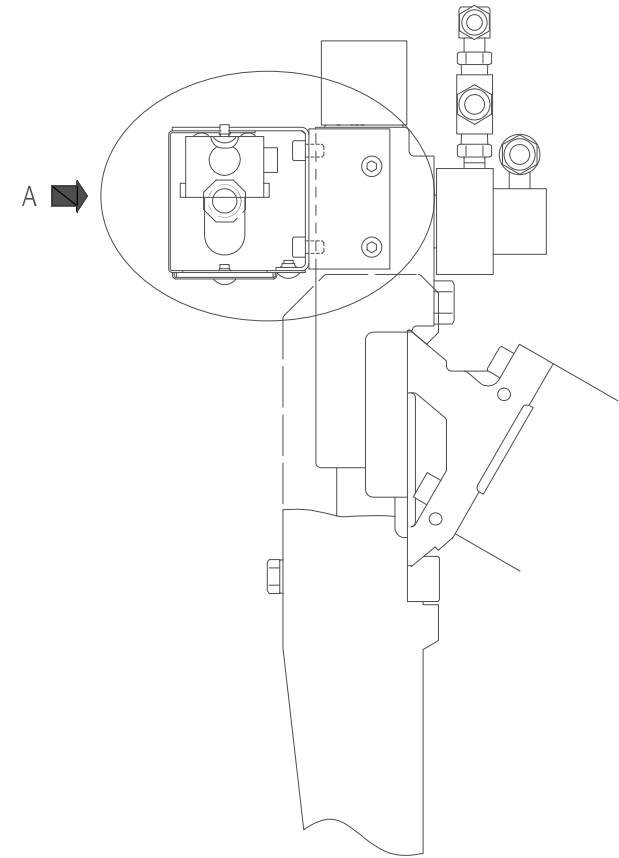
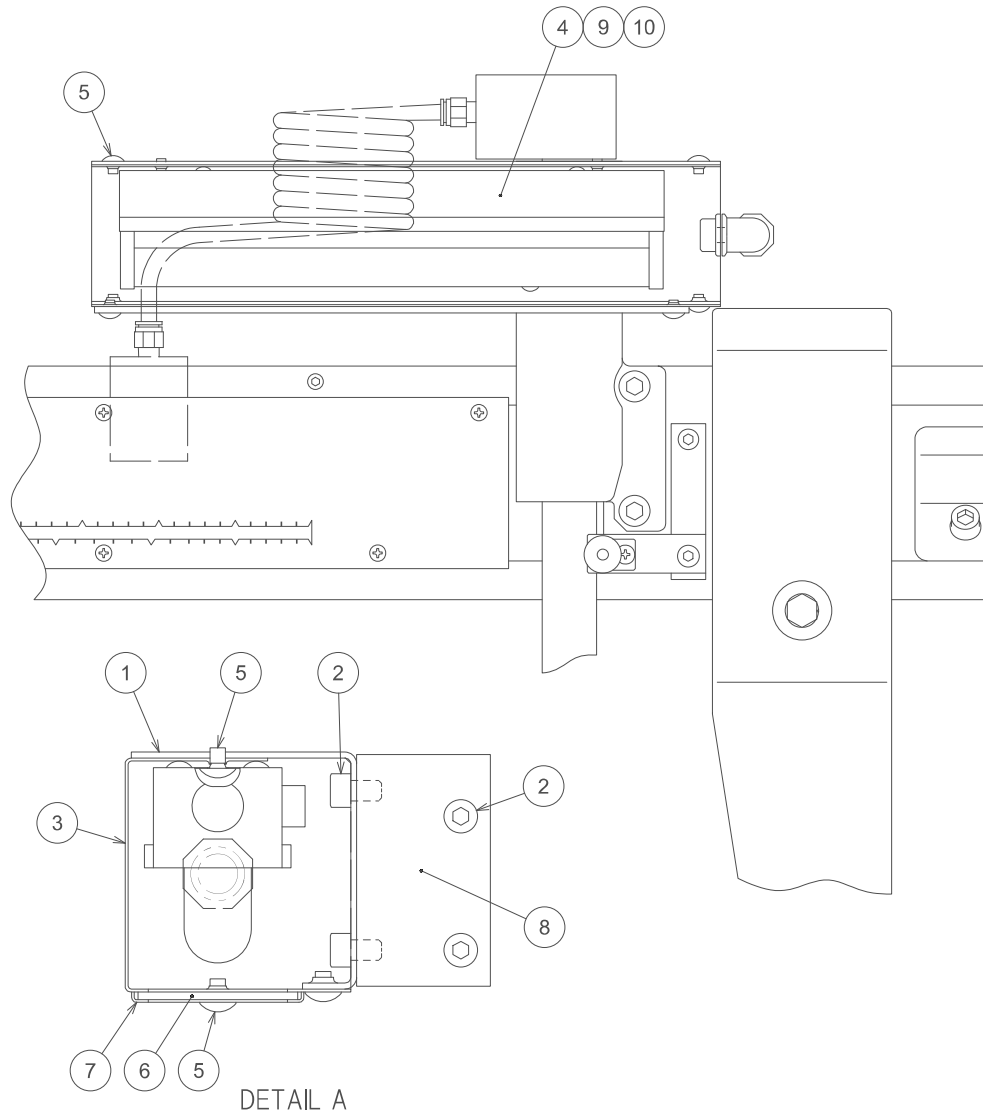

127885---

Unit No. 66
Work Light

Index	Code	Parts Name	Drawing No.	Type	Maker	Q'ty	Note
1	10301181	Upper Cover	1278448---			1	
2	10323206	Hex Socket Cap Screw	P330230002	M8X12	JIS	4	
3	10301182	Under Cover	1278449--A			1	
4	10300107	Fluorescent Lamp Unit	7720422---	M-1114T11-A/B		1	
5	10332134	Truss Head Screw	P334130010	M6X8	JIS	8	
6	10336503	Acrylic Cover	1280832			1	
7	10336504	Cover Holder	1280834			1	
8	10419353	Bracket	142966813	W90XT4.5		1	
9	10337544	Fluorescence Lamp	P850308001	FL10W	NEC	1	
10	10583709	Accessory for Fluorescent Lamp	P850318001	FG-7E	NEC	1	

Unit No. 67
 Electric DOM(1) <Cable>

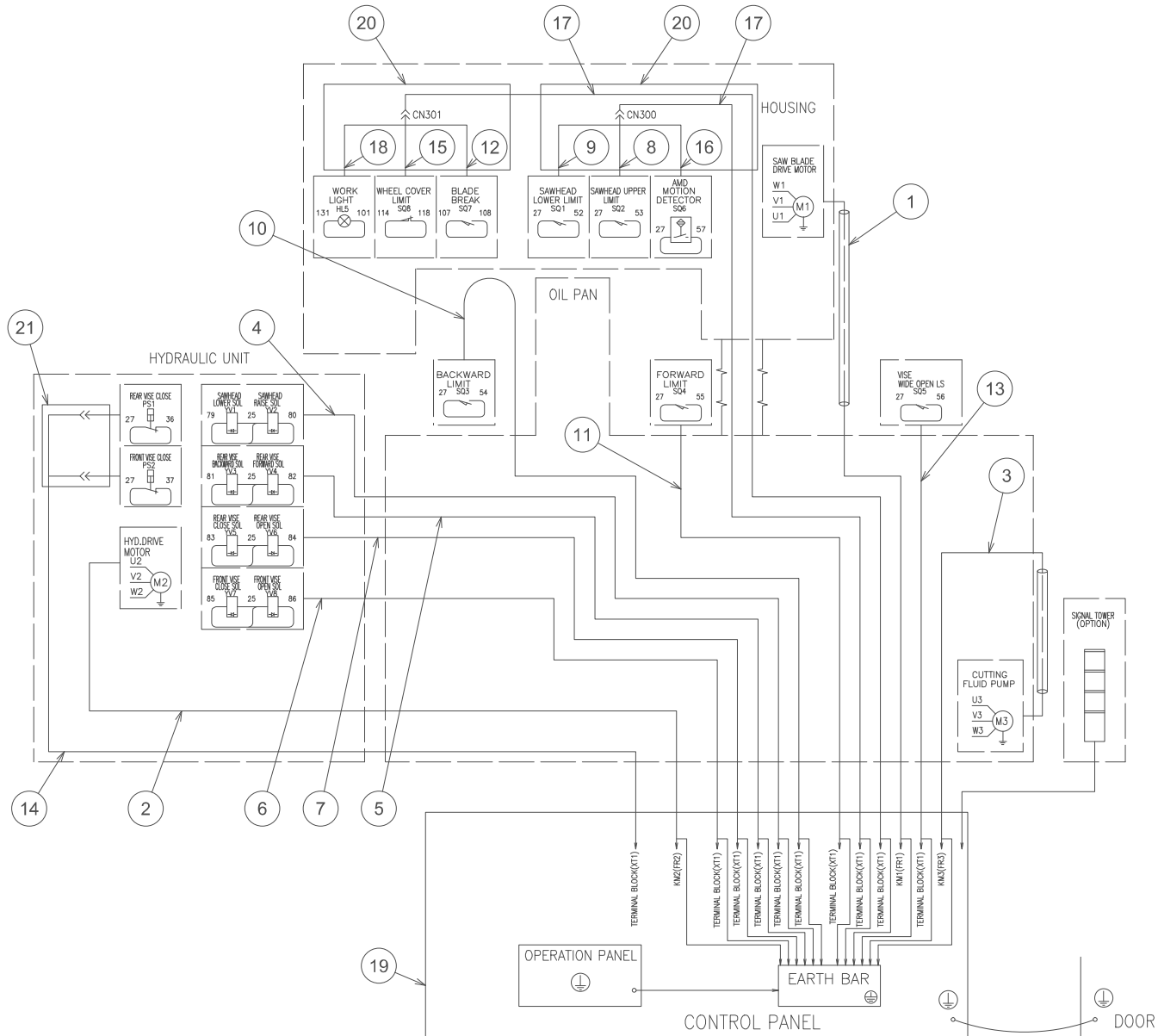

RB02517--B

Unit No. 67
Electric DOM(1)

Index	Code	Parts Name	Drawing No.	Type	Maker	Q'ty	Note
1	10301332	Saw Blade Motor Cable	RB0153801A			1	
2	10301333	Hydraulic Motor Cable	RB0153802A			1	
3	10301334	Cutting Fluid Pump Motor Cable	RB0153803A			1	
4	10301337	Rase/Lower SOL Cable	RB0156906A			1	
5	10301338	Forward/Backward SOL Cable	RB0156907A			1	
6	10301339	Front Vise SOL Cable	RB0156908A			1	
7	10301340	Rear Vise SOL Cable	RB0156909A			1	
8	10301341	Sawhead Upper Limit LS Cable	RB0156911A			1	
9	10301342	Lower Limit LS Cable	RB0156912A			1	
10	10301343	Backward Limit LS Cable	RB0156913A			1	
11	10301344	Forward Limit LS Cable	RB0156914A			1	
12	10301345	Blade Break LS Cable	RB0156915A			1	
13	10301346	Sawhead Upper End Limit LS Cable	RB0156916A			1	
14	10301102	Front/Rear Vise Close LS Cable	RB0155117C			1	
15	10301541	Cover Open Limit Switch Cable	RB0251718B			1	
16	10301348	AMD Motion Detector Cable	RB0156920B			1	
17	10301542	Housing Junction Cable	RB0251721B			1	
18	10301351	Working Light Cable	RB0156923A			1	
19	10301543	Control Panel	RB0251726A			1	

Unit No. 67
Electric DOM(1)

Index	Code	Parts Name	Drawing No.	Type	Maker	Q'ty	Note
20	10301118	Vinyl Tube	RB0160005-	D50XL400(T=0.5)		2	
21	10301124	Vinyl Tube	RB0160011-	D50XL200(T=0.5)		2	

Unit No. 68
 Electric DOM(2)-1/2 <Electrical Enclosure>

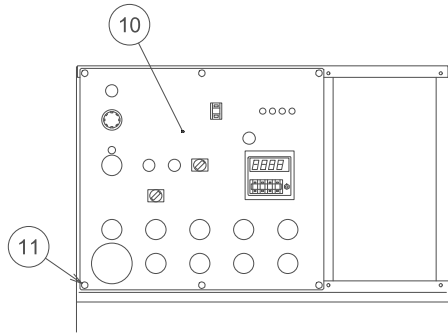

VIEW A

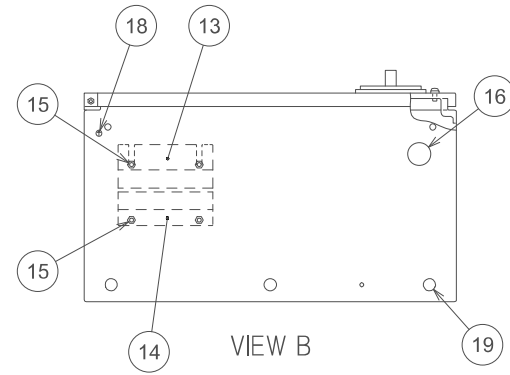
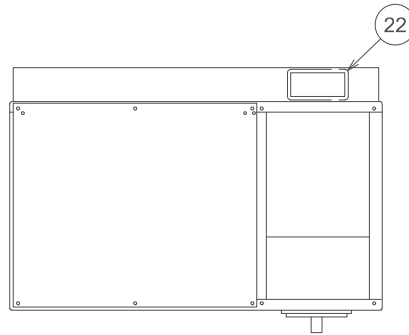

VIEW B

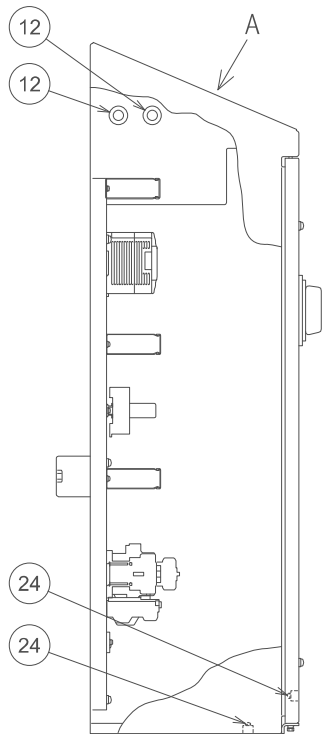

A

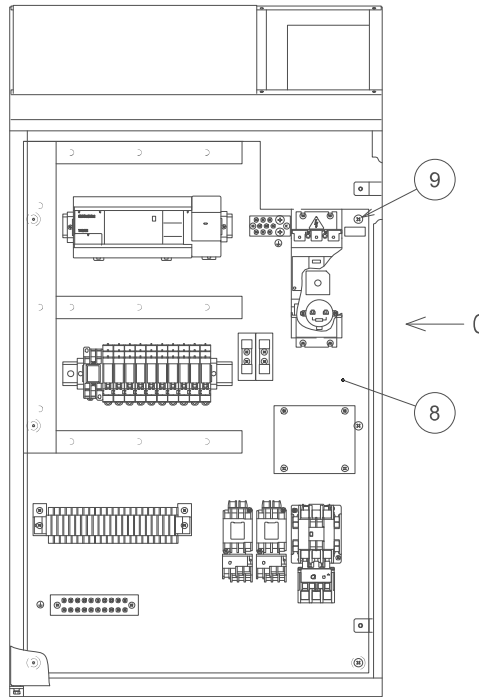

C

B

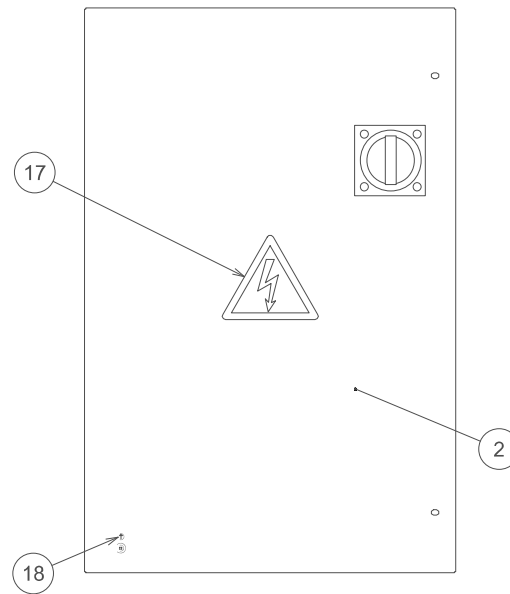

RB02512--C

Unit No. 68

Electric DOM(2)-2/2 <Electrical Enclosure>

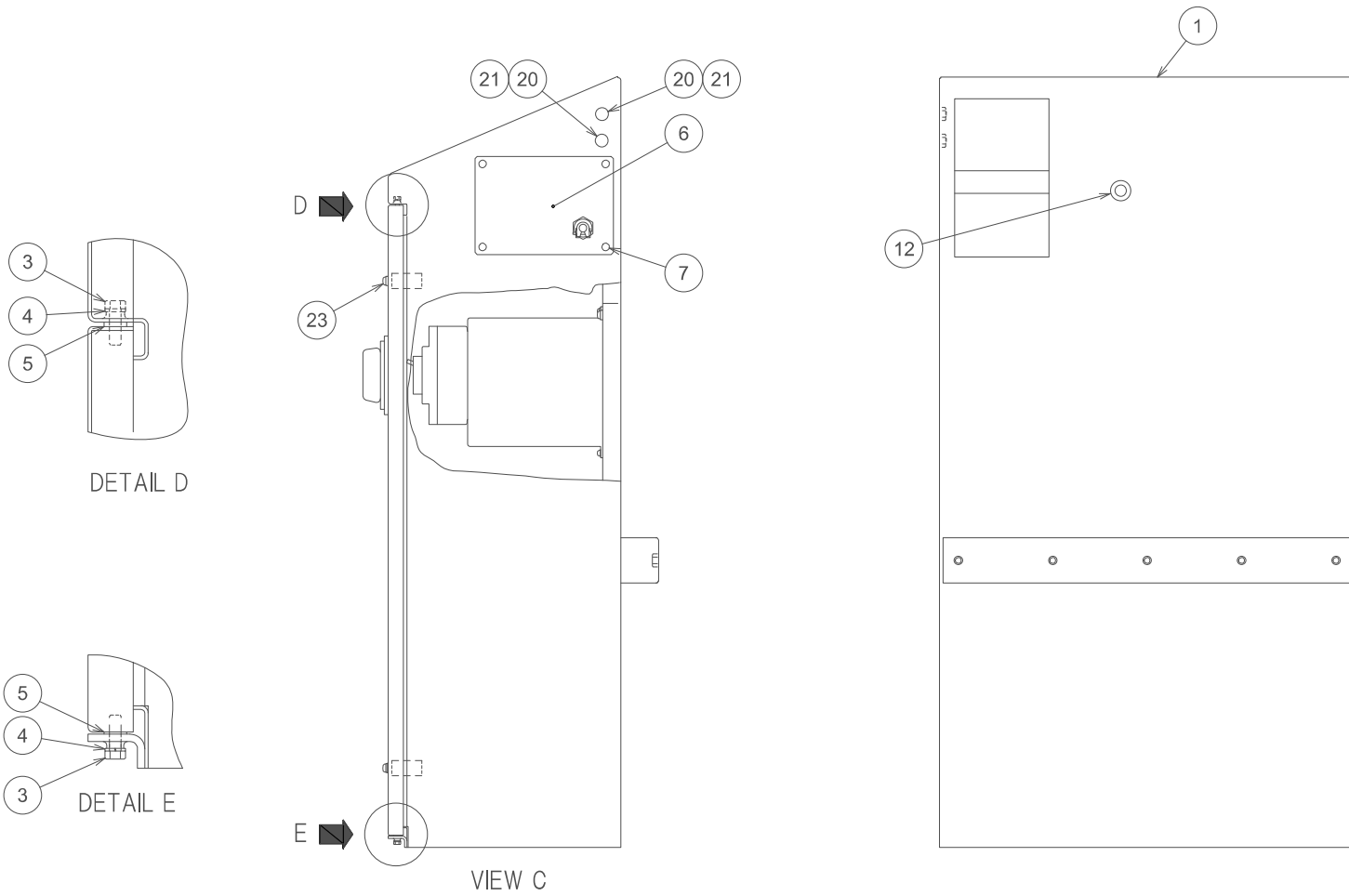

RB02512--C

Unit No. 68
Electric DOM(2)

Index	Code	Parts Name	Drawing No.	Type	Maker	Q'ty	Note
1	10300821	Control Box	RB00774--C			1	
2	10300822	Control Box Cover	RB00775--B			1	
3	10325830	Bolt	P330010005	M5X16	JIS	2	
4	10322215	Spring Washer	P336050004	5	JIS	2	
5	10323127	Washer	P336000059	5(Polished Round)	JIS	2	
6	10300824	Cover	RB00776--B			1	
7	10322224	Pan Head Screw	P334100039	M5X10	JIS	4	
8	10301355	Panel Arrangement	RB01576--B			1	
9	10325313	Pan Head Screw	P334100058	M6X16	JIS	6	
10	10300825	Control Panel	RB00778--C			1	
11	10372307	Truss Head Screw	P334130009	M5X12	JIS	6	
12	10301115	Bush for Cable	RB0160001-	D22		3	
13	10300830	Cable Retainer A	RB00779--B			1	
14	10300831	Cable Retainer B	RB00780--B			1	
15	10380944	Sems Pan Head Screw	P334200063	M6X16(Spring/Polished Round)	JIS	4	
16	10301119	CAPCON	RB0160006-	D34		1	
17	10301069	Charging Mark D	RB01517---	125MM		1	
18	10301068	Sticker (Ground)	RB01516---			1	
19	10301120	Grommet	RB0160007-	D18		1	

Unit No. 68
Electric DOM(2)

Index	Code	Parts Name	Drawing No.	Type	Maker	Q'ty	Note
20	10321923	Washer	P336000006	8(Normal)	JIS	2	
21	10342325	Hex Socket Cap Screw	P330230004	M8X15		2	
22	10301121	Grommet	RB0160008-	W4XL250		1	
23	10322133	Truss Head Screw	P334130014	M6X20	JIS	2	
24	10589252	Sems Pan Head Screw	P334200013	M4X10(Spring/Polished Round)	JIS	2	

Unit No. 69
 Electric DOM(3)-2/2 <Panel Arrangement>

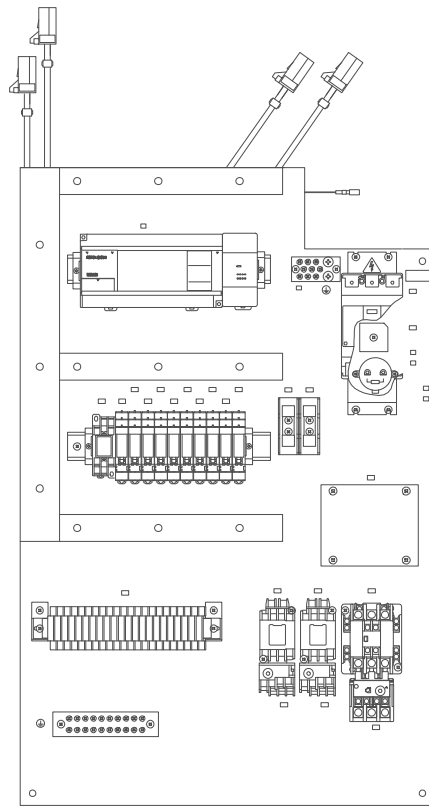

B

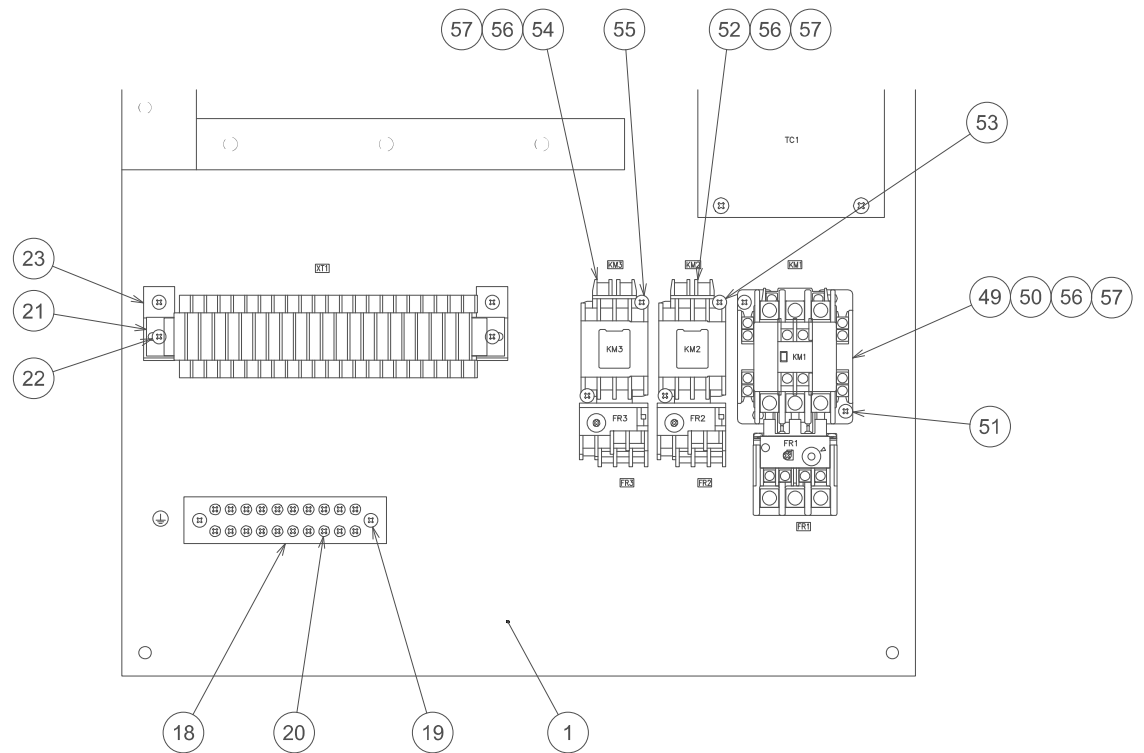

DETAIL B

RB01576--B

Unit No. 69
Electric DOM(3)

Index	Code	Parts Name	Drawing No.	Type	Maker	Q'ty	Note
1	10300832	Control Panel	RB00781--C			1	
2	10300833	Breaker Bracket	RB00782--C			1	
3	10589252	Sems Pan Head Screw	P334200013	M4X10(Spring/Polished Round)	JIS	4	
4	10301310	Low Voltage Breaker	P812008031	NF125-CVF-3P-75A	mitsubishi	1	QF1
5	10300194	Accessory (Low Voltage Breaker)	P812098064	F-05SV	mitsubishi	1	
6	10300195	Accessory (Low Voltage Breaker)	P812098065	TCL-05SV3	mitsubishi	1	
7	10300207	Rectifier	P840068014	KBPC35-10	SUMGLE	1	VC1
8	10589252	Sems Pan Head Screw	P334200013	M4X10(Spring/Polished Round)	JIS	1	
9	10300211	Aluminum Capacitor	P840108041	50V10000Micro Farad	HWAKAI	1	C0
10	10300212	Resistor	P841128056	RS2W(5.1 kOhm)	YCX	1	R0
11	10589250	Sems Pan Head Screw	P334200010	M3X10(Spring/Polished Round)	JIS	2	
12	10364540	Fuse	P842064018	FCF2-3	FUJI Electric	1	FU1
13	10380702	Fuse	P842064020	FCF2-10	FUJI Electric	1	FU2
14	10382471	Fuse Holder	P842202004	F-7140	SATO PARTS	2	
15	10380683	Sems Pan Head Screw	P334200034	M4X16(Spring/Polished Round)	JIS	4	
16	10300180	Transformer	P772008054	JBK5-400	JUCHE	1	TC1
17	10380975	Sems Pan Head Screw	P334200047	M5X12(Spring/Polished Round)	JIS	4	
18	10300834	Ground Bar	RB00783--A			1	
19	10380683	Sems Pan Head Screw	P334200034	M4X16(Spring/Polished Round)	JIS	2	

Unit No. 69
Electric DOM(3)

Index	Code	Parts Name	Drawing No.	Type	Maker	Q'ty	Note
20	10380682	Sems Pan Head Screw	P334200032	M4X6(Spring/Polished Round)	JIS	20	
21	10301128	Terminal Block ASSY	RB0251501B			1	XT1
22	10380683	Sems Pan Head Screw	P334200034	M4X16(Spring/Polished Round)	JIS	4	
23	10301117	Tilting Attachment	RB0160003-	(Conform to) BP23-2S		2	
24	10300224	Duct for Wiring	P869509272	GW-33100(L=275)	GIANTLOK	3	
25	10589252	Sems Pan Head Screw	P334200013	M4X10(Spring/Polished Round)	JIS	9	
26	10300217	Terminal Base	P864038171	FH-1007(L=250)	FEHUA	2	
27	10589252	Sems Pan Head Screw	P334200013	M4X10(Spring/Polished Round)	JIS	6	
28	10337281	Terminal Parts	P864052008	BNL6	IDEC	4	
29	10300181	Control Relay	P800002091	MY2N-CR-AC100V	OMRON	1	
30	10300215	Accessory for Connector	P862188020	PYF08A	OMRON	1	
31	10349515	Accessory for Connector	P862188011	PYC-A1	OMRON	1	KA4
32	10589483	Control Relay	P800002075	G2R-1-SND-DC24V	OMRON	10	KA5A,KA5-KA13
33	10589484	Accessory for Control Relay	P800082015	P2RF-05-E	OMRON	10	
34	10300225	Duct for Wiring	P869509274	GW-48100(L=460)	OLEANDER	1	
35	10589252	Sems Pan Head Screw	P334200013	M4X10(Spring/Polished Round)	JIS	3	
36	10428836	Programmable Controller	P767406003	FX1N-60MR-ES/UL	mitsubishi	1	E1
37	10582249	Accessory (Program Controller)	P767486019	FX1N-EEPROM-8L	mitsubishi	1	
38	10300836	PLC Ladder	RB00785--A	HA252V12.2		1	

Unit No. 69
Electric DOM(3)

Index	Code	Parts Name	Drawing No.	Type	Maker	Q'ty	Note
39	10301076	Cable CN100F	RB0154801A			1	CN100
40	10301077	Cable CN101F	RB0154802A			1	CN101
41	10301078	Cable CN102F	RB0154803A			1	CN102
42	10300214	Plug Type Terminal	P862148060	PC-2005F	NICHIFU	1	25
43	10300835	Ground Bar	RB00784--A			1	PE
44	10380683	Sems Pan Head Screw	P334200034	M4X16(Spring/Polished Round)	JIS	2	
45	10380682	Sems Pan Head Screw	P334200032	M4X6(Spring/Polished Round)	JIS	9	
46	10300140	Sems Pan Head Screw	P334200084	M6X8(Spring/Polished Round)	JIS	2	
47	10300143	Washer	P336000074	6(Polished Round)T=1.0	JIS	2	
48	10301123	Charging Mark	RB0160010-	20MM		1	
49	10301309	Magnet Switch	P810044071	SW-N1(18A)AC100V	FUJI Electric	1	KM1,FR1
50	10589493	Accessory (Magnet Switch)	P810184001	SZ-A20	FUJI Electric	1	
51	10380683	Sems Pan Head Screw	P334200034	M4X16(Spring/Polished Round)	JIS	2	
52	10380692	Magnet Switch	P810044028	SW-05(2A)AC100V	FUJI Electric	1	KM2,FR2
53	10380683	Sems Pan Head Screw	P334200034	M4X16(Spring/Polished Round)	JIS	2	
54	10580714	Magnet Switch	P810044135	SW-0(0.8A)AC100V	FUJI Electric	1	KM3,FR3
55	10380683	Sems Pan Head Screw	P334200034	M4X16(Spring/Polished Round)	JIS	2	
56	10301116	Spark Killer	RB0160002-	(Conform to) SKVB104120		3	
57	10300209	Varistor	P840078054	TUR20D471K	JOCOL	9	

Unit No. 69
Electric DOM(3)

Index	Code	Parts Name	Drawing No.	Type	Maker	Q'ty	Note
58	10301079	Name Plate	RB0154804A			1	List Only
59	10301080	Cable CN103F	RB0154805-			1	CN103

Unit No. 70
 Electric DOM(4) <Control Panel>

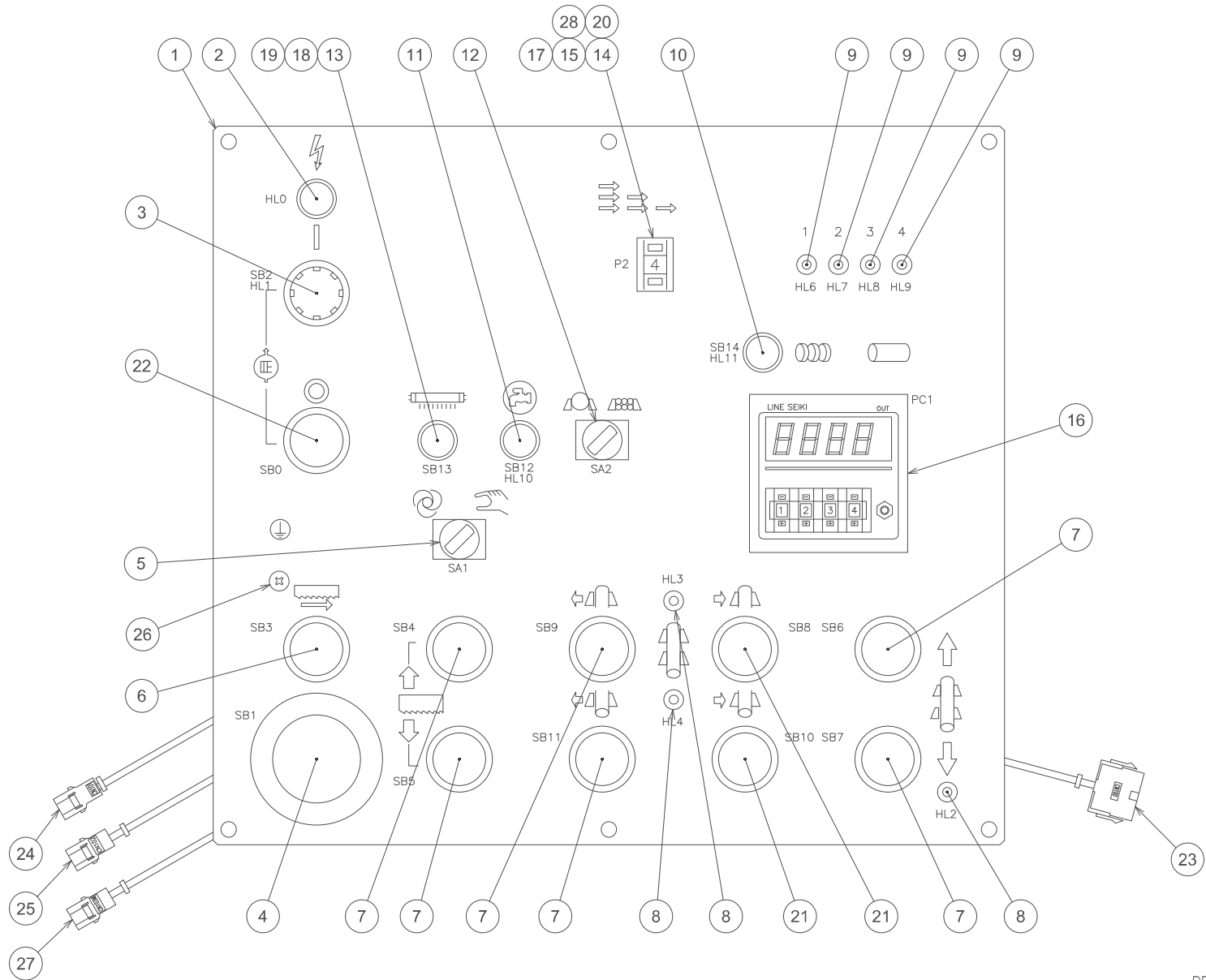

RB00778--C

Unit No. 70
Electric DOM(4)

Index	Code	Parts Name	Drawing No.	Type	Maker	Q'ty	Note
1	10300837	Name Plate	RB00786--C			1	
2	10300213	Indicator Apparatus	P843024023	AH165-ZWH3	FUJI Electric	1	HL0
3	10579339	Illuminated Pushbutton	P822084031	AR22F0L-10H3W	FUJI Electric	1	SB2,HL1
4	10300199	Push Button Switch	P821084115	AR22V0R-01R	FUJI Electric	1	SB1
5	10337159	Key Select Switch	P820004027	AH165-P2B11	FUJI Electric	1	SA1
6	10579341	Push Button Switch	P821084154	AR22G2R-20W	FUJI Electric	1	SB3
7	10589510	Push Button Switch	P821084080	AR22F0R-10W	FUJI Electric	6	SB4-SB7,SB9,SB11
8	10583452	Indicator Apparatus	P843188016	DB24-89WUS	MARUYASU DENGYO	3	HL2,HL3,HL4
9	10583452	Indicator Apparatus	P843188016	DB24-89WUS	MARUYASU DENGYO	4	HL6-HL9
10	10300204	Illuminated Pushbutton	P822064076	AH165-L5W11E3	FUJI Electric	1	SB14,HL11
11	10300205	Illuminated Pushbutton	P822064077	AH165-L5W11H3	FUJI Electric	1	SB12,HL10
12	10337159	Key Select Switch	P820004027	AH165-P2B11	FUJI Electric	1	SA2
13	10337521	Push Button Switch	P821064009	AH165-E5W22	FUJI Electric	1	SB13
14	10380727	Key Select Switch	P820022002	A7BS-206-S-1	OMRON	1	P2
15	10380728	Accessory for Rotary Switch	P820082002	A7B-C(Connector)	OMRON	1	
16	10300103	Electronic Counter	7720235---	MD-144M-509	LINE SEIKI	1	PC1
17	10380870	Accessory for Rotary Switch	P820082001	A7B-M-1(Setting Plate)	OMRON	1	
18	10300208	Varistor	P840078053	TUR20D271K	JOCOL	1	
19	10301116	Spark Killer	RB0160002-	(Conform to) SKVB104120		1	

Unit No. 70
Electric DOM(4)

Index	Code	Parts Name	Drawing No.	Type	Maker	Q'ty	Note
20	10300838	Counter Cover	RB00787---			1	
21	10300200	Push Button Switch	P821084195	AR22G2R-10W	FUJI Electric	2	SB8,SB10
22	10300198	Push Button Switch	P821084081	AR22F0R-01B	FUJI Electric	1	SB0
23	10300826	Cable CN100M	RB0077801A			1	CN100
24	10300827	Cable CN101M	RB0077802A			1	
25	10300828	Cable CN102M	RB0077803A			1	
26	10589252	Sems Pan Head Screw	P334200013	M4X10(Spring/Polished Round)	JIS	1	
27	10300829	Cable CN103M	RB0077804-			1	
28	10300150	Cable Band	P381058169	AB100	Tyton	2	

Unit No. 71
 Electric US(1) <Cable>

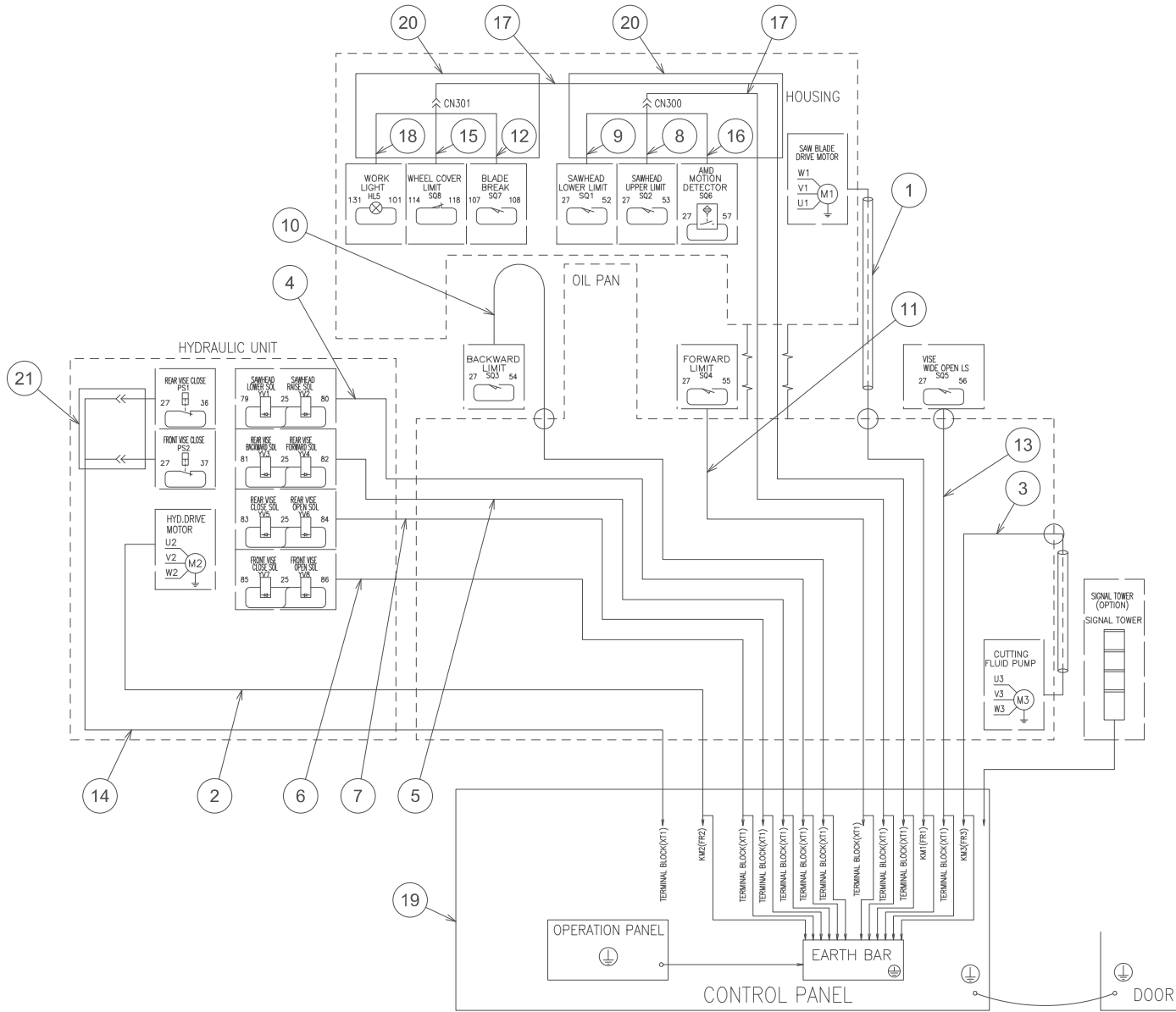

RB02511--C

Unit No. 71
Electric US(1)

Index	Code	Parts Name	Drawing No.	Type	Maker	Q'ty	Note
1	10301332	Saw Blade Motor Cable	RB0153801A			1	
2	10301333	Hydraulic Motor Cable	RB0153802A			1	
3	10301334	Cutting Fluid Pump Motor Cable	RB0153803A			1	
4	10301337	Rase/Lower SOL Cable	RB0156906A			1	
5	10301338	Forward/Backward SOL Cable	RB0156907A			1	
6	10301339	Front Vise SOL Cable	RB0156908A			1	
7	10301340	Rear Vise SOL Cable	RB0156909A			1	
8	10301341	Sawhead Upper Limit LS Cable	RB0156911A			1	
9	10301342	Lower Limit LS Cable	RB0156912A			1	
10	10301343	Backward Limit LS Cable	RB0156913A			1	
11	10301344	Forward Limit LS Cable	RB0156914A			1	
12	10301345	Blade Break LS Cable	RB0156915A			1	
13	10301346	Sawhead Upper End Limit LS Cable	RB0156916A			1	
14	10301102	Front/Rear Vise Close LS Cable	RB0155117C			1	
15	10301541	Cover Open Limit Switch Cable	RB0251718B			1	
16	10301348	AMD Motion Detector Cable	RB0156920B			1	
17	10301542	Housing Junction Cable	RB0251721B			1	
18	10301351	Working Light Cable	RB0156923A			1	
19	10301538	Control Panel	RB0251140A			1	

Unit No. 71
Electric US(1)

Index	Code	Parts Name	Drawing No.	Type	Maker	Q'ty	Note
20	10301118	Vinyl Tube	RB0160005-	D50XL400(T=0.5)		2	
21	10301124	Vinyl Tube	RB0160011-	D50XL200(T=0.5)		2	

Unit No. 72
 Electric US(2)-1/2 <Electrical Enclosure>

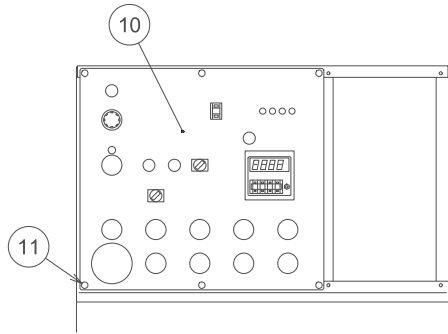

VIEW A

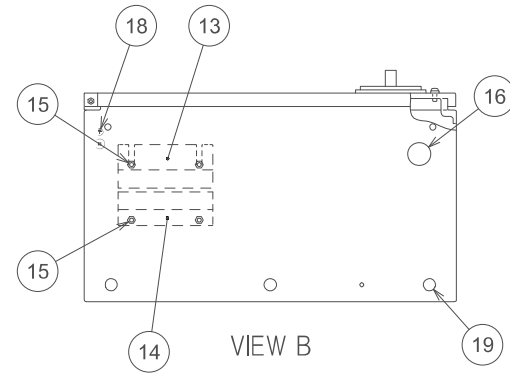
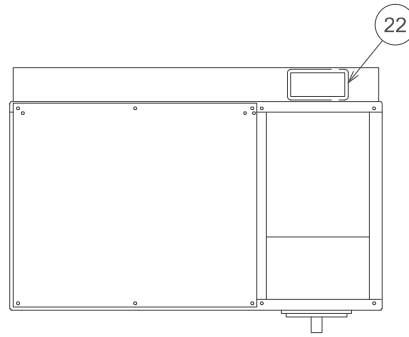

VIEW B

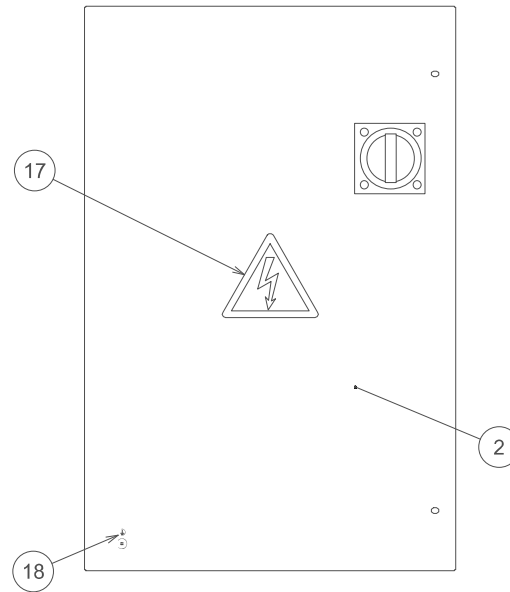
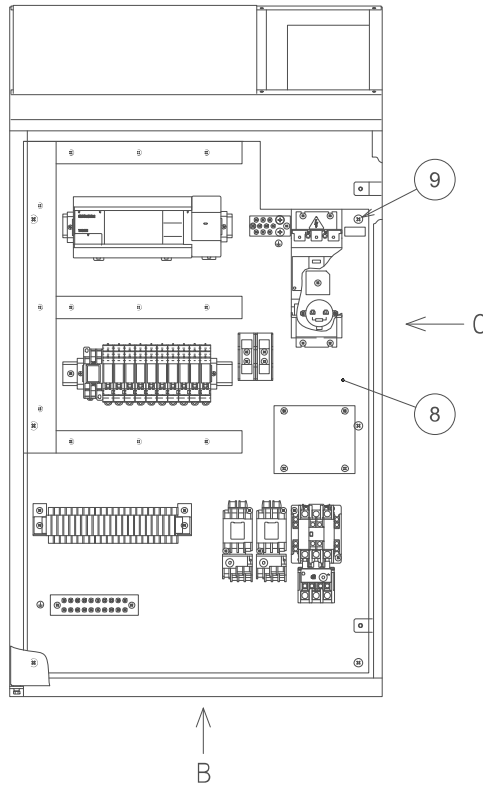
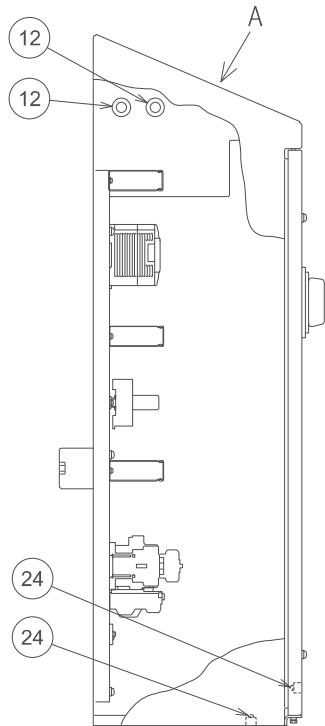

RB01532--B

Unit No. 72
Electric US(2)-2/2 <Electrical Enclosure>

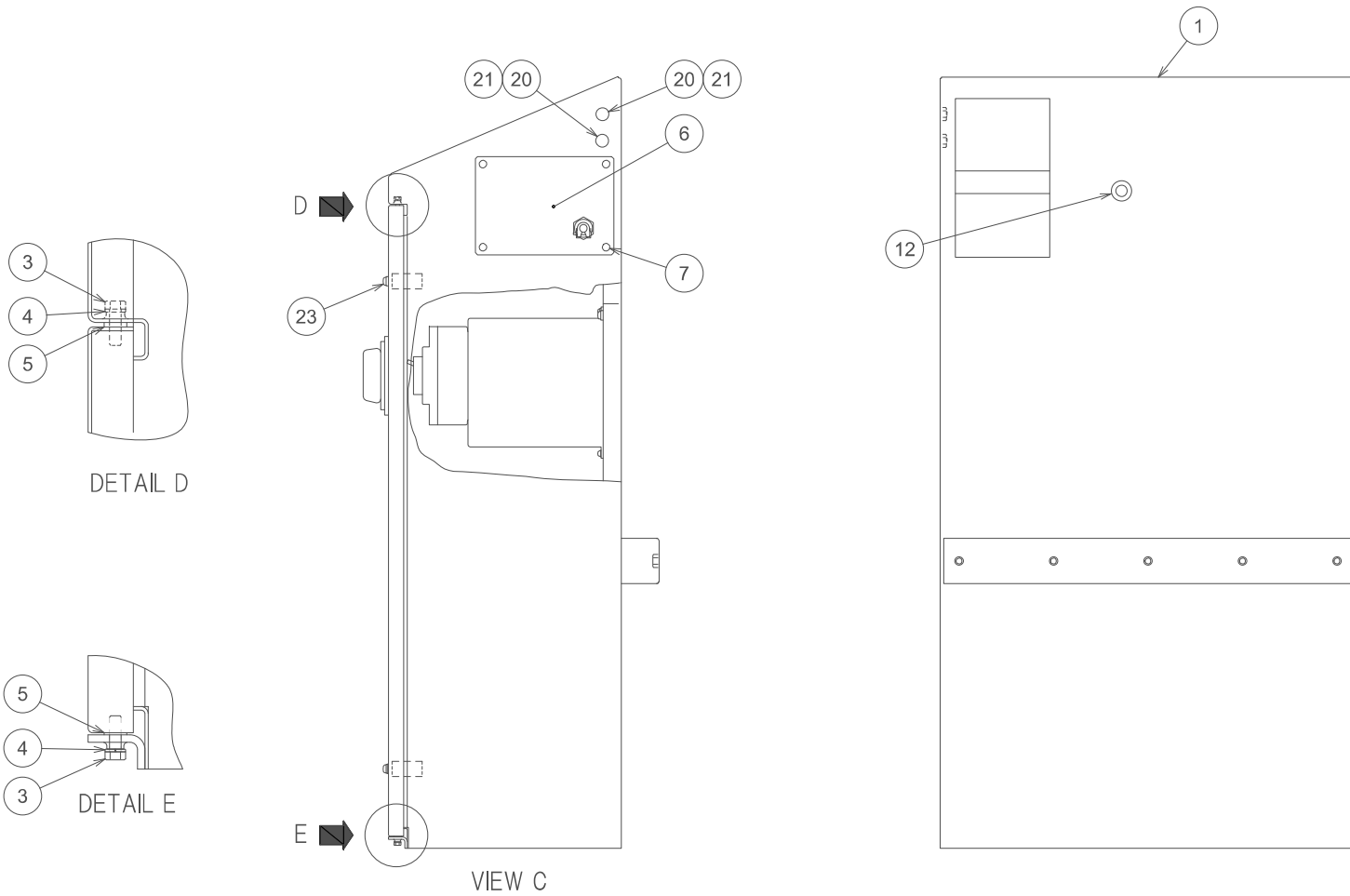

RB01532--B

Unit No. 72
Electric US(2)

Index	Code	Parts Name	Drawing No.	Type	Maker	Q'ty	Note
1	10300821	Control Box	RB00774--C			1	
2	10300822	Control Box Cover	RB00775--B			1	
3	10325830	Bolt	P330010005	M5X16	JIS	2	
4	10322215	Spring Washer	P336050004	5	JIS	2	
5	10323127	Washer	P336000059	5(Polished Round)	JIS	2	
6	10300824	Cover	RB00776--B			1	
7	10322224	Pan Head Screw	P334100039	M5X10	JIS	4	
8	10301357	Panel Arrangement	RB01578--B			1	
9	10325313	Pan Head Screw	P334100058	M6X16	JIS	6	
10	10300825	Control Panel	RB00778--C			1	
11	10372307	Truss Head Screw	P334130009	M5X12	JIS	6	
12	10301115	Bush for Cable	RB0160001-	D22		3	
13	10300830	Cable Retainer A	RB00779--B			1	
14	10300831	Cable Retainer B	RB00780--B			1	
15	10380944	Sems Pan Head Screw	P334200063	M6X16(Spring/Polished Round)	JIS	4	
16	10301119	CAPCON	RB0160006-	D34		1	
17	10301069	Charging Mark D	RB01517---	125MM		1	
18	10301068	Sticker (Ground)	RB01516---			1	
19	10301120	Grommet	RB0160007-	D18		1	

Unit No. 72
Electric US(2)

Index	Code	Parts Name	Drawing No.	Type	Maker	Q'ty	Note
20	10321923	Washer	P336000006	8(Normal)	JIS	2	
21	10342325	Hex Socket Cap Screw	P330230004	M8X15		2	
22	10301121	Grommet	RB0160008-	W4XL250		1	
23	10322133	Truss Head Screw	P334130014	M6X20	JIS	2	
24	10589252	Sems Pan Head Screw	P334200013	M4X10(Spring/Polished Round)	JIS	2	

Unit No. 73
 Electric US(3)-1/2 <Panel Arrangement>

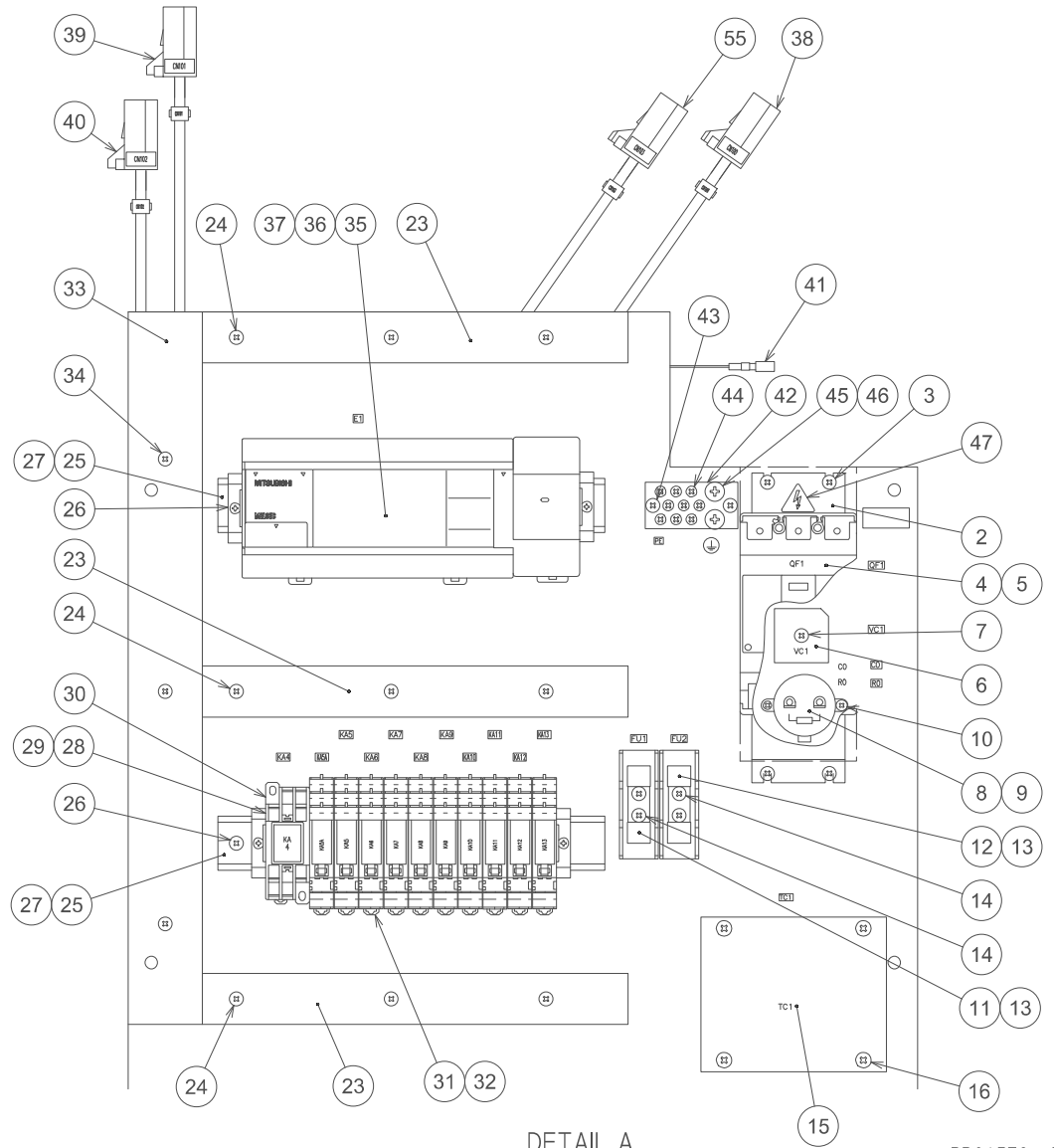
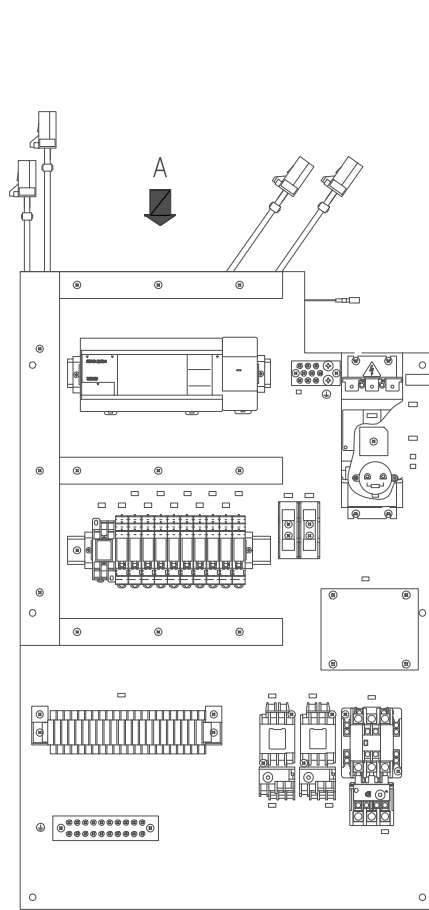

DETAIL A

RB01578--B

Unit No. 73
 Electric US(3)-2/2 <Panel Arrangement>

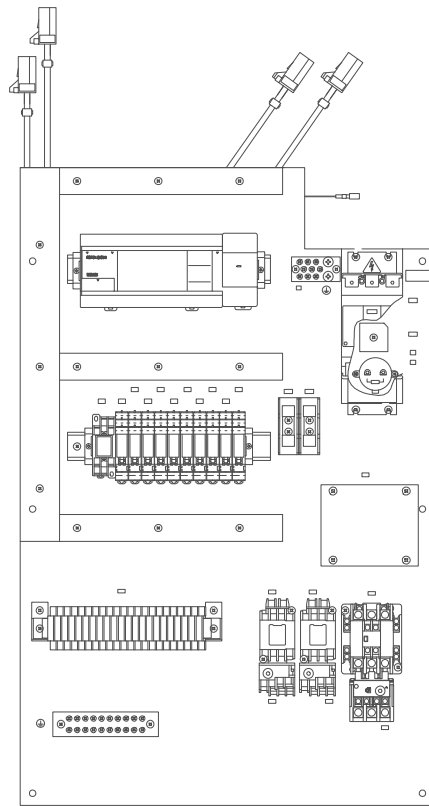

↑
B

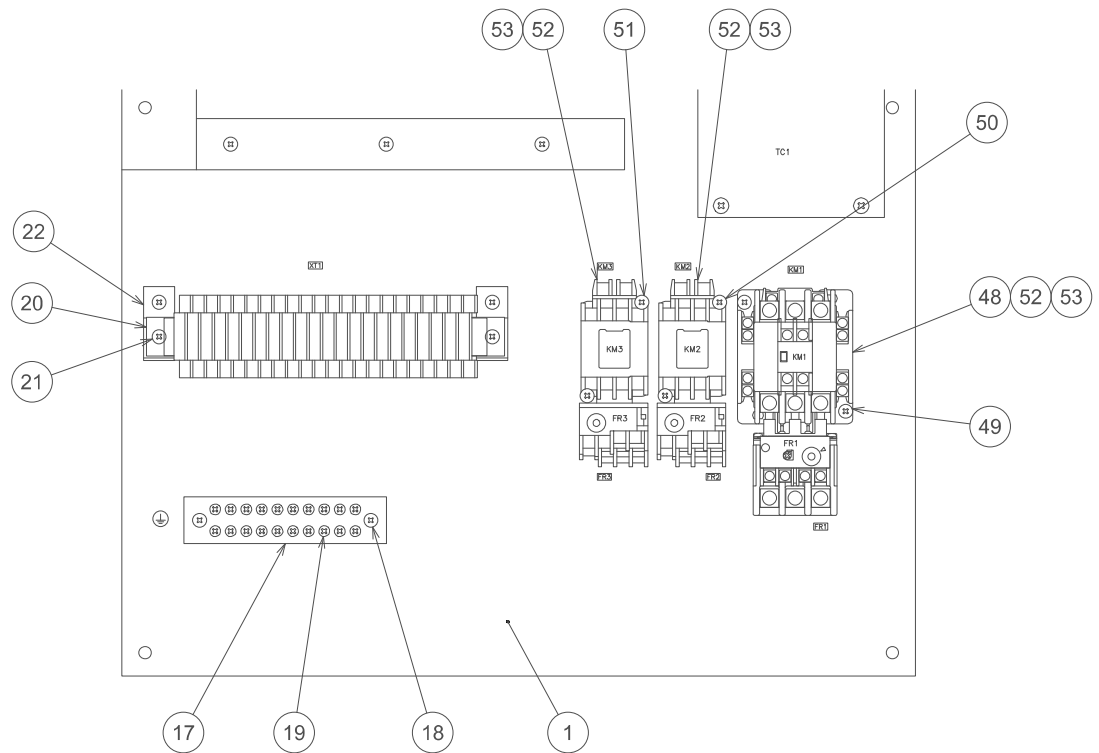

DETAIL B

RB01578--B

Unit No. 73
Electric US(3)

Index	Code	Parts Name	Drawing No.	Type	Maker	Q'ty	Note
1	10300832	Control Panel	RB00781--C			1	
2	10300833	Breaker Bracket	RB00782--C			1	
3	10589252	Sems Pan Head Screw	P334200013	M4X10(Spring/Polished Round)	JIS	4	
4	10300194	Accessory (Low Voltage Breaker)	P812098064	F-05SV	MITSUBISHI	1	
5	10300195	Accessory (Low Voltage Breaker)	P812098065	TCL-05SV3	MITSUBISHI	1	
6	10300207	Rectifier	P840068014	KBPC35-10	SUMGLE	1	
7	10589252	Sems Pan Head Screw	P334200013	M4X10(Spring/Polished Round)	JIS	1	
8	10300211	Aluminum Capacitor	P840108041	50V10000Micro Farad	HWAKAI	1	C0
9	10300212	Resistor	P841128056	RS2W(5.1 kOhm)	YCX	1	R0
10	10589250	Sems Pan Head Screw	P334200010	M3X10(Spring/Polished Round)	JIS	2	
11	10364540	Fuse	P842064018	FCF2-3	FUJI Electric	1	FU1
12	10380702	Fuse	P842064020	FCF2-10	FUJI Electric	1	FU2
13	10382471	Fuse Holder	P842202004	F-7140	SATO PARTS	2	
14	10380683	Sems Pan Head Screw	P334200034	M4X16(Spring/Polished Round)	JIS	4	
15	10300180	Transformer	P772008054	JBK5-400	JUCHE	1	TC1
16	10380975	Sems Pan Head Screw	P334200047	M5X12(Spring/Polished Round)	JIS	4	
17	10300834	Ground Bar	RB00783--A			1	
18	10380683	Sems Pan Head Screw	P334200034	M4X16(Spring/Polished Round)	JIS	2	
19	10380682	Sems Pan Head Screw	P334200032	M4X6(Spring/Polished Round)	JIS	20	

Unit No. 73
Electric US(3)

Index	Code	Parts Name	Drawing No.	Type	Maker	Q'ty	Note
20	10301128	Terminal Block ASSY	RB0251501B			1	
21	10380683	Sems Pan Head Screw	P334200034	M4X16(Spring/Polished Round)	JIS	4	
22	10301117	Tilting Attachment	RB0160003-	(Conform to) BP23-2S		2	
23	10300224	Duct for Wiring	P869509272	GW-33100(L=275)	GIANTLOK	3	
24	10589252	Sems Pan Head Screw	P334200013	M4X10(Spring/Polished Round)	JIS	9	
25	10300217	Terminal Base	P864038171	FH-1007(L=250)	FEHUA	2	
26	10589252	Sems Pan Head Screw	P334200013	M4X10(Spring/Polished Round)	JIS	6	
27	10337281	Terminal Parts	P864052008	BNL6	IDEC	4	
28	10300181	Control Relay	P800002091	MY2N-CR-AC100V	OMRON	1	
29	10300215	Accessory for Connector	P862188020	PYF08A	OMRON	1	
30	10349515	Accessory for Connector	P862188011	PYC-A1	OMRON	1	KA4
31	10589483	Control Relay	P800002075	G2R-1-SND-DC24V	OMRON	10	KA5A,KA5-KA13
32	10589484	Accessory for Control Relay	P800082015	P2RF-05-E	OMRON	10	
33	10300225	Duct for Wiring	P869509274	GW-48100(L=460)	OLEANDER	1	
34	10589252	Sems Pan Head Screw	P334200013	M4X10(Spring/Polished Round)	JIS	3	
35	10428836	Programmable Controller	P767406003	FX1N-60MR-ES/UL	MITSUBISHI	1	E1
36	10582249	Accessory (Program Controller)	P767486019	FX1N-EEPROM-8L	MITSUBISHI	1	
37	10300836	PLC Ladder	RB00785--A	HA252V12.2		1	
38	10301076	Cable CN100F	RB0154801A			1	CN100

Unit No. 73
Electric US(3)

Index	Code	Parts Name	Drawing No.	Type	Maker	Q'ty	Note
39	10301077	Cable CN101F	RB0154802A			1	CN101
40	10301078	Cable CN102F	RB0154803A			1	CN102
41	10300214	Plug Type Terminal	P862148060	PC-2005F	NICHIFU	1	25
42	10300835	Ground Bar	RB00784--A			1	PE
43	10380683	Sems Pan Head Screw	P334200034	M4X16(Spring/Polished Round)	JIS	2	
44	10380682	Sems Pan Head Screw	P334200032	M4X6(Spring/Polished Round)	JIS	9	
45	10300140	Sems Pan Head Screw	P334200084	M6X8(Spring/Polished Round)	JIS	2	
46	10300143	Washer	P336000074	6(Polished Round)T=1.0	JIS	2	
47	10301123	Charging Mark	RB0160010-	20MM		1	
48	10589493	Accessory (Magnet Switch)	P810184001	SZ-A20	FUJI Electric	1	KM1,FR1
49	10380683	Sems Pan Head Screw	P334200034	M4X16(Spring/Polished Round)	JIS	2	
50	10380683	Sems Pan Head Screw	P334200034	M4X16(Spring/Polished Round)	JIS	2	
51	10380683	Sems Pan Head Screw	P334200034	M4X16(Spring/Polished Round)	JIS	2	
52	10301116	Spark Killer	RB0160002-	(Conform to) SKVB104120		3	
53	10300210	Varistor	P840078056	TUR20D112K	JOCOL	9	
54	10301079	Name Plate	RB0154804A			1	List Only/US(AC230V)/ AS(AC460V)
55	10301080	Cable CN103F	RB0154805-			1	CN103

Unit No. 74
 Electric US(4) <Control Panel>

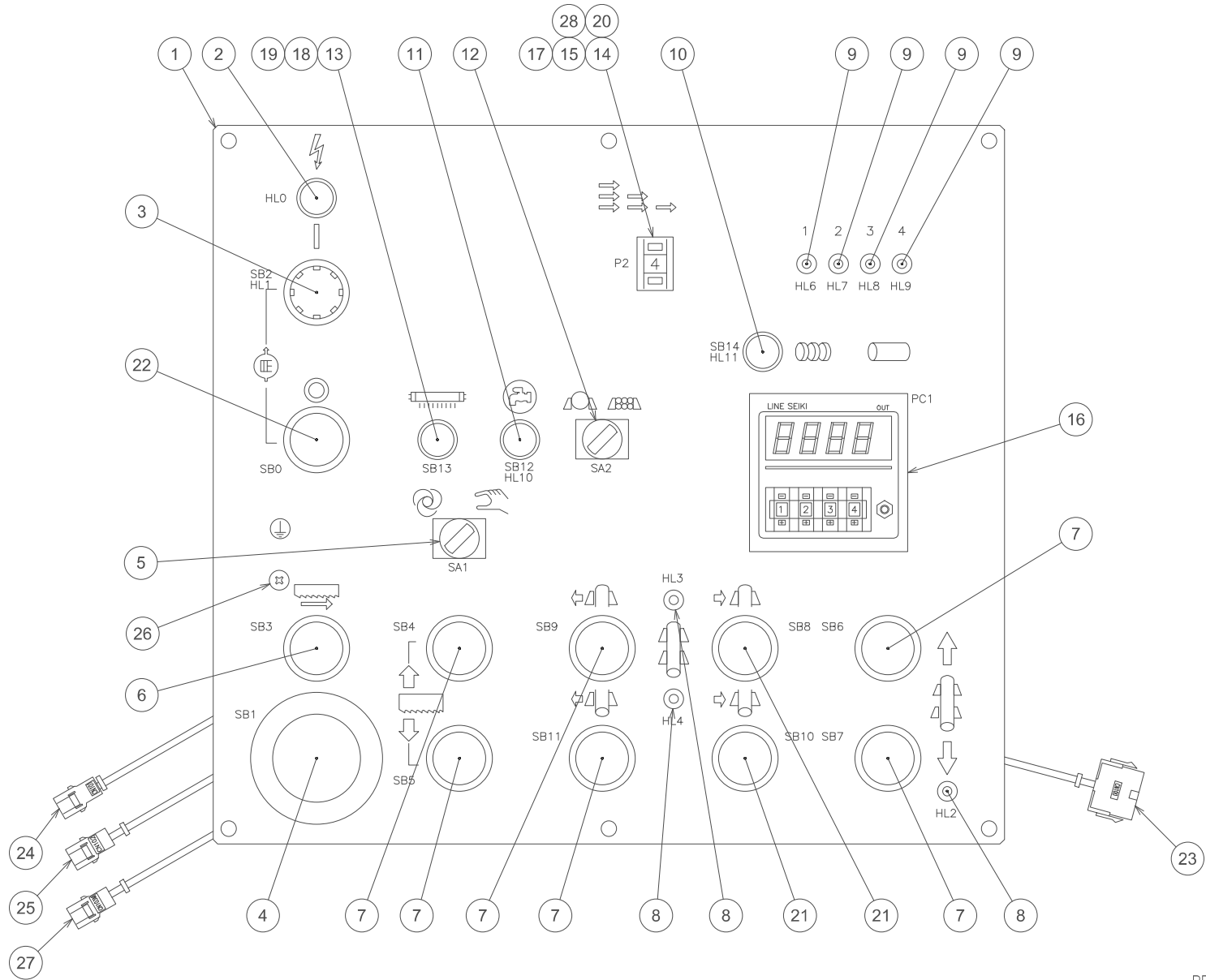

RB00778--C

Unit No. 74
Electric US(4)

Index	Code	Parts Name	Drawing No.	Type	Maker	Q'ty	Note
1	10300837	Name Plate	RB00786--C			1	
2	10300213	Indicator Apparatus	P843024023	AH165-ZWH3	FUJI Electric	1	HL0
3	10579339	Illuminated Pushbutton	P822084031	AR22F0L-10H3W	FUJI Electric	1	SB2,HL1
4	10300199	Push Button Switch	P821084115	AR22V0R-01R	FUJI Electric	1	SB1
5	10337159	Key Select Switch	P820004027	AH165-P2B11	FUJI Electric	1	SA1
6	10579341	Push Button Switch	P821084154	AR22G2R-20W	FUJI Electric	1	SB3
7	10589510	Push Button Switch	P821084080	AR22F0R-10W	FUJI Electric	6	SB4-SB7,SB9,SB11
8	10583452	Indicator Apparatus	P843188016	DB24-89WUS	MARUYASU DENGYO	3	HL2,HL3,HL4
9	10583452	Indicator Apparatus	P843188016	DB24-89WUS	MARUYASU DENGYO	4	HL6-HL9
10	10300204	Illuminated Pushbutton	P822064076	AH165-L5W11E3	FUJI Electric	1	SB14,HL11
11	10300205	Illuminated Pushbutton	P822064077	AH165-L5W11H3	FUJI Electric	1	SB12,HL10
12	10337159	Key Select Switch	P820004027	AH165-P2B11	FUJI Electric	1	SA2
13	10337521	Push Button Switch	P821064009	AH165-E5W22	FUJI Electric	1	SB13
14	10380727	Key Select Switch	P820022002	A7BS-206-S-1	OMRON	1	P2
15	10380728	Accessory for Rotary Switch	P820082002	A7B-C(Connector)	OMRON	1	
16	10300103	Electronic Counter	7720235---	MD-144M-509	LINE SEIKI	1	PC1
17	10380870	Accessory for Rotary Switch	P820082001	A7B-M-1(Setting Plate)	OMRON	1	
18	10300208	Varistor	P840078053	TUR20D271K	JOCOL	1	
19	10301116	Spark Killer	RB0160002-	(Conform to) SKVB104120		1	

Unit No. 74
Electric US(4)

Index	Code	Parts Name	Drawing No.	Type	Maker	Q'ty	Note
20	10300838	Counter Cover	RB00787---			1	
21	10300200	Push Button Switch	P821084195	AR22G2R-10W	FUJI Electric	2	SB8,SB10
22	10300198	Push Button Switch	P821084081	AR22F0R-01B	FUJI Electric	1	SB0
23	10300826	Cable CN100M	RB0077801A			1	CN100
24	10300827	Cable CN101M	RB0077802A			1	
25	10300828	Cable CN102M	RB0077803A			1	
26	10589252	Sems Pan Head Screw	P334200013	M4X10(Spring/Polished Round)	JIS	1	
27	10300829	Cable CN103M	RB0077804-			1	
28	10300150	Cable Band	P381058169	AB100	Tyton	2	

Unit No. 75
 Electric US(5)-2/2 <US Specification Component>

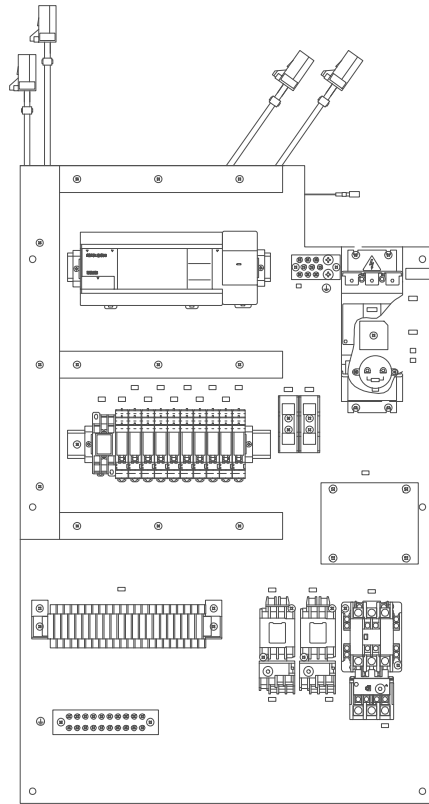

B

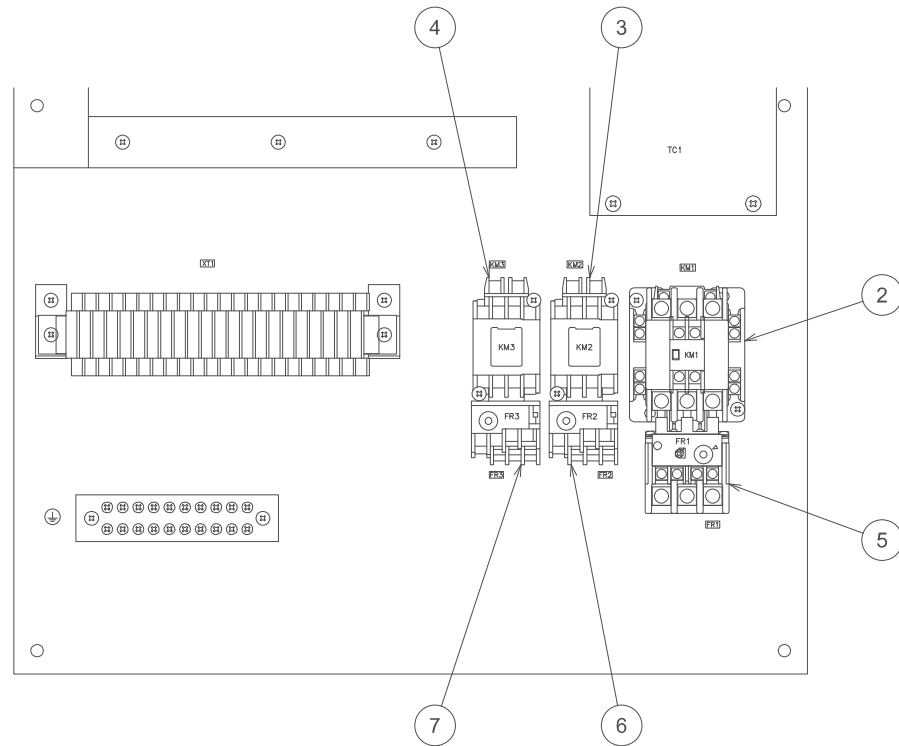

DETAIL B

RB01533---
 (RB01578--B)

Unit No. 75
Electric US(5)

Index	Code	Parts Name	Drawing No.	Type	Maker	Q'ty	Note
1	10301310	Low Voltage Breaker	P812008031	NF125-CVF-3P-75A	MITSUBISHI	1	for 230V / QF1
1	10300187	Low Voltage Breaker	P812008026	NF32-SV-3P-30A	MITSUBISHI	1	for 460V / QF1
2	10579414	Magnet Switch	P810044149	SW-N1/3H(18A)AC100V	FUJI Electric	1	KM1
3	10579403	Magnet Switch	P810044143	SW-05/3H(5A)AC100V-2A	FUJI Electric	1	KM2
4	10579406	Magnet Switch	P810044144	SW-0/3H(0.48A)AC100V	FUJI Electric	1	KM3
5	10579411	Protection Relay	P801004110	TR-N2/3(7-11A)	FUJI Electric	1	for 460V / FR1
6	10301307	Protection Relay	P801004149	TR-0N/3(2.2-3.4A)	FUJI Electric	1	for 460V / FR2
7	10301306	Protection Relay	P801004148	TR-0N/3(0.3-0.45A)	FUJI Electric	1	for 460V / FR3

Unit No. 76
 Electric EU(1) <Cable>

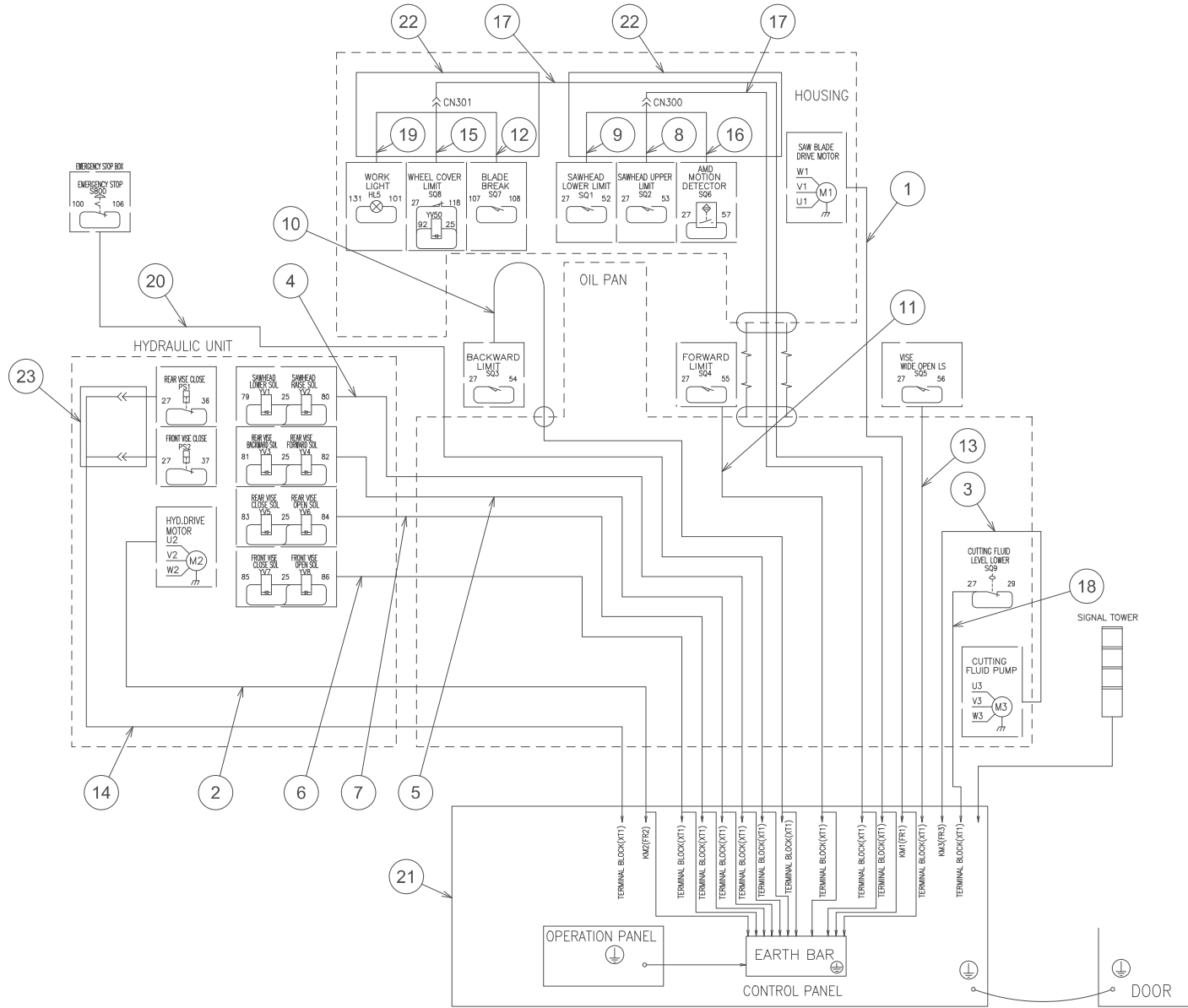

RB01569--C

Unit No. 76
Electric EU(1)

Index	Code	Parts Name	Drawing No.	Type	Maker	Q'ty	Note
1	10301332	Saw Blade Motor Cable	RB0153801A			1	
2	10301333	Hydraulic Motor Cable	RB0153802A			1	
3	10301334	Cutting Fluid Pump Motor Cable	RB0153803A			1	
4	10301337	Rase/Lower SOL Cable	RB0156906A			1	
5	10301338	Forward/Backward SOL Cable	RB0156907A			1	
6	10301339	Front Vise SOL Cable	RB0156908A			1	
7	10301340	Rear Vise SOL Cable	RB0156909A			1	
8	10301341	Sawhead Upper Limit LS Cable	RB0156911A			1	
9	10301342	Lower Limit LS Cable	RB0156912A			1	
10	10301343	Backward Limit LS Cable	RB0156913A			1	
11	10301344	Forward Limit LS Cable	RB0156914A			1	
12	10301345	Blade Break LS Cable	RB0156915A			1	
13	10301346	Sawhead Upper End Limit LS Cable	RB0156916A			1	
14	10301102	Front/Rear Vise Close LS Cable	RB0155117C			1	
15	10301347	Cover Open Limit Switch Cable	RB0156918B			1	
16	10301348	AMD Motion Detector Cable	RB0156920B			1	
17	10301349	Housing Junction Cable	RB0156921B			1	
18	10301350	Cutting Fluid Level Gauge Cable	RB0156922A			1	
19	10301351	Working Light Cable	RB0156923A			1	

Unit No. 76
Electric EU(1)

Index	Code	Parts Name	Drawing No.	Type	Maker	Q'ty	Note
20	10301352	Emergency Stop Button Cable	RB0156927A			1	
21	10301353	Control Panel	RB0156928A			1	
22	10301118	Vinyl Tube	RB0160005-	D50XL400(T=0.5)		2	
23	10301124	Vinyl Tube	RB0160011-	D50XL200(T=0.5)		1	

Unit No. 77
 Electric EU(2)-1/2 <Electrical Enclosure>

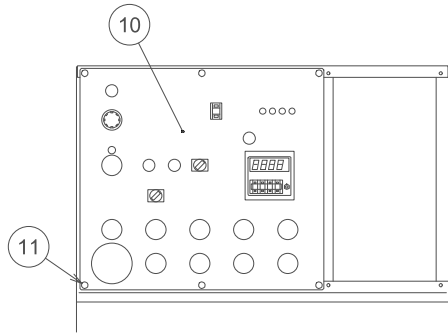

VIEW A

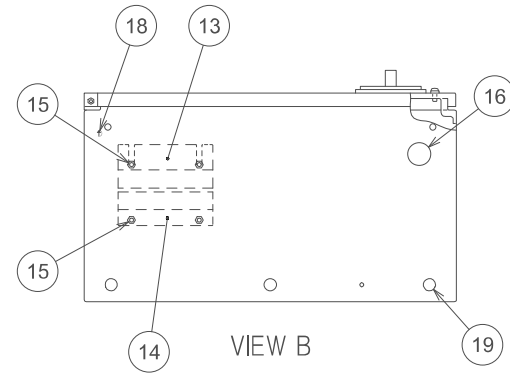
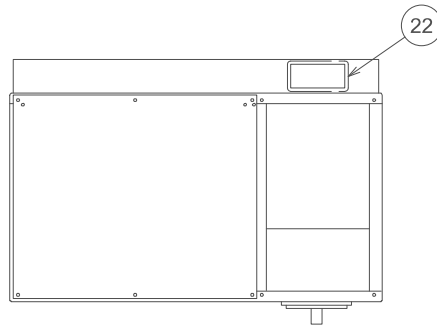

VIEW B

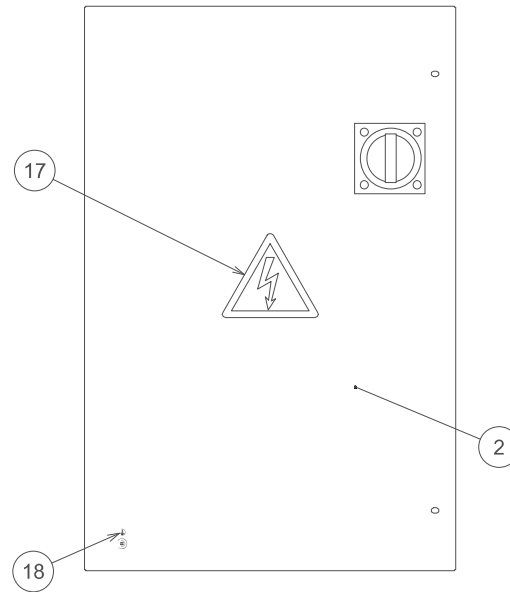
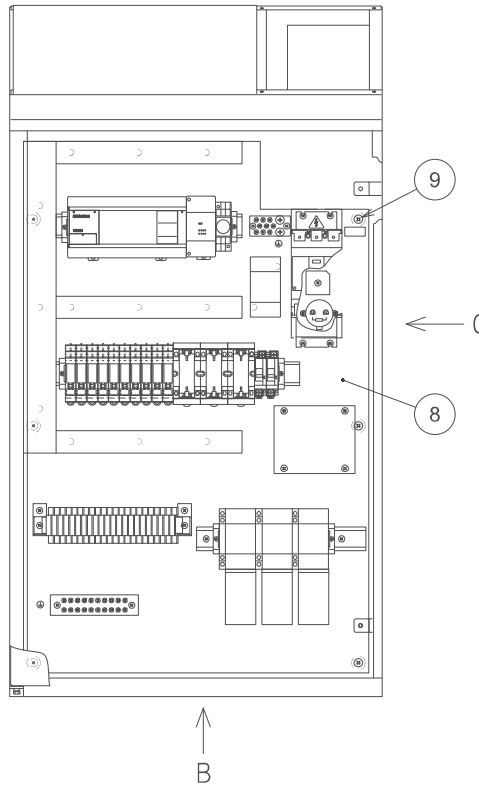
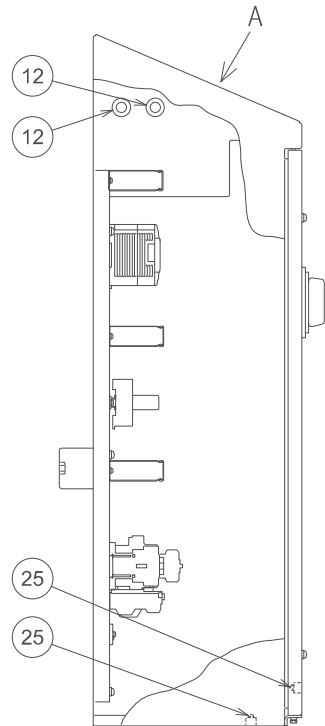

RB01570--C

Unit No. 77
Electric EU(2)-2/2 <Electrical Enclosure>

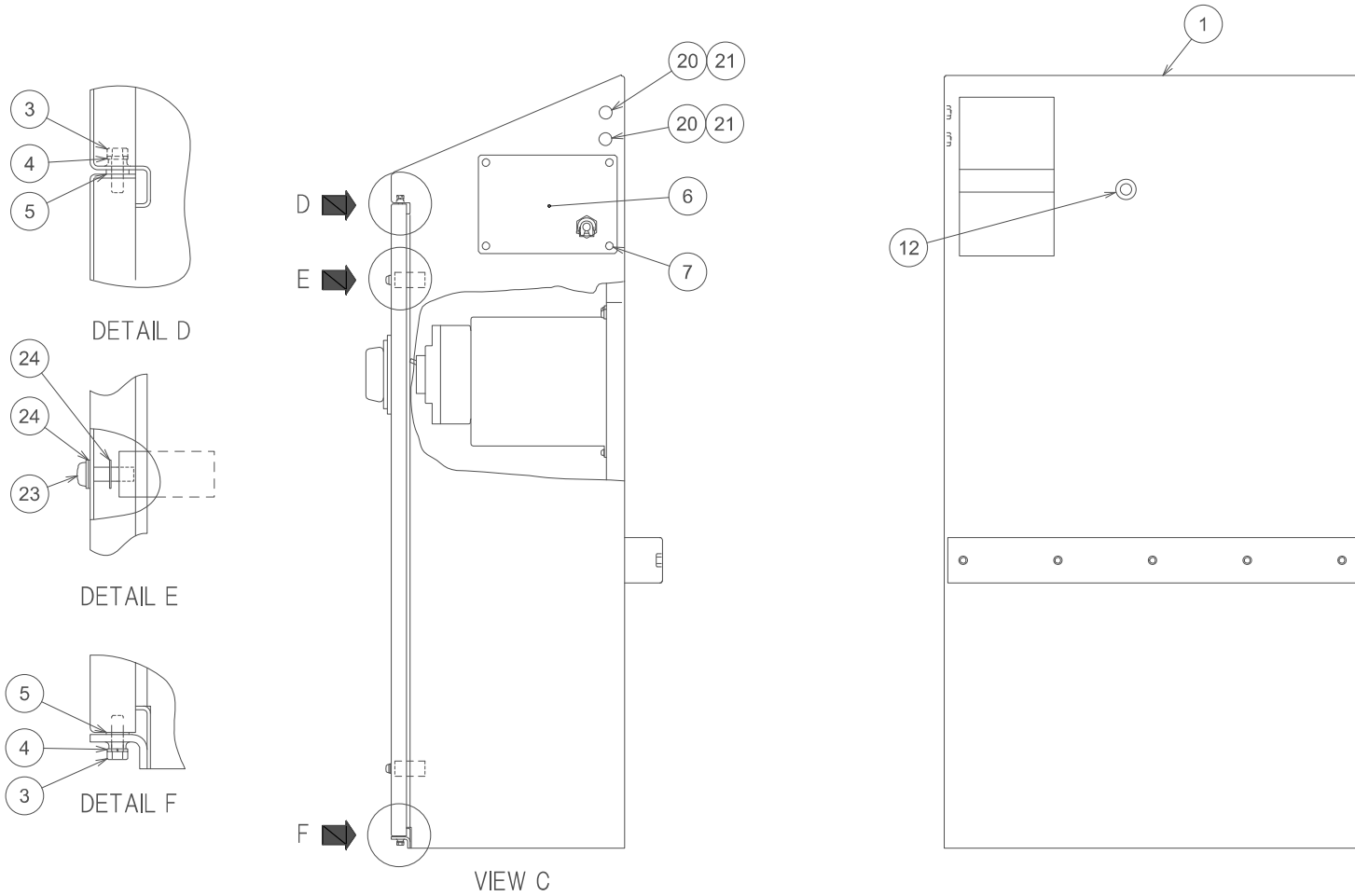

RB01570--C

Unit No. 77
Electric EU(2)

Index	Code	Parts Name	Drawing No.	Type	Maker	Q'ty	Note
1	10300821	Control Box	RB00774--C			1	
2	10300822	Control Box Cover	RB00775--B			1	
3	10325830	Bolt	P330010005	M5X16	JIS	2	
4	10322215	Spring Washer	P336050004	5	JIS	2	
5	10323127	Washer	P336000059	5(Polished Round)	JIS	2	
6	10300824	Cover	RB00776--B			1	
7	10322224	Pan Head Screw	P334100039	M5X10	JIS	4	
8	10301356	Panel Arrangement	RB01577--B			1	
9	10325313	Pan Head Screw	P334100058	M6X16	JIS	6	
10	10300825	Control Panel	RB00778--C			1	
11	10372307	Truss Head Screw	P334130009	M5X12	JIS	6	
12	10301115	Bush for Cable	RB0160001-	D22		3	
13	10300830	Cable Retainer A	RB00779--B			1	
14	10300831	Cable Retainer B	RB00780--B			1	
15	10380944	Sems Pan Head Screw	P334200063	M6X16(Spring/Polished Round)	JIS	4	
16	10301119	CAPCON	RB0160006-	D34		1	
17	10301069	Charging Mark D	RB01517---	125MM		1	
18	10301068	Sticker (Ground)	RB01516---			1	
19	10301120	Grommet	RB0160007-	D18		1	

Unit No. 77
Electric EU(2)

Index	Code	Parts Name	Drawing No.	Type	Maker	Q'ty	Note
20	10321923	Washer	P336000006	8(Normal)	JIS	2	
21	10342325	Hex Socket Cap Screw	P330230004	M8X15		2	
22	10301121	Grommet	RB0160008-	W4XL250		1	
23	10322133	Truss Head Screw	P334130014	M6X20	JIS	2	
24	10380967	Washer	P336198002	TM-147-4	TOCHIGIYA	4	
25	10589252	Sems Pan Head Screw	P334200013	M4X10(Spring/Polished Round)	JIS	2	

Unit No. 78
 Electric EU(3)-1/2 <Panel Arrangement>

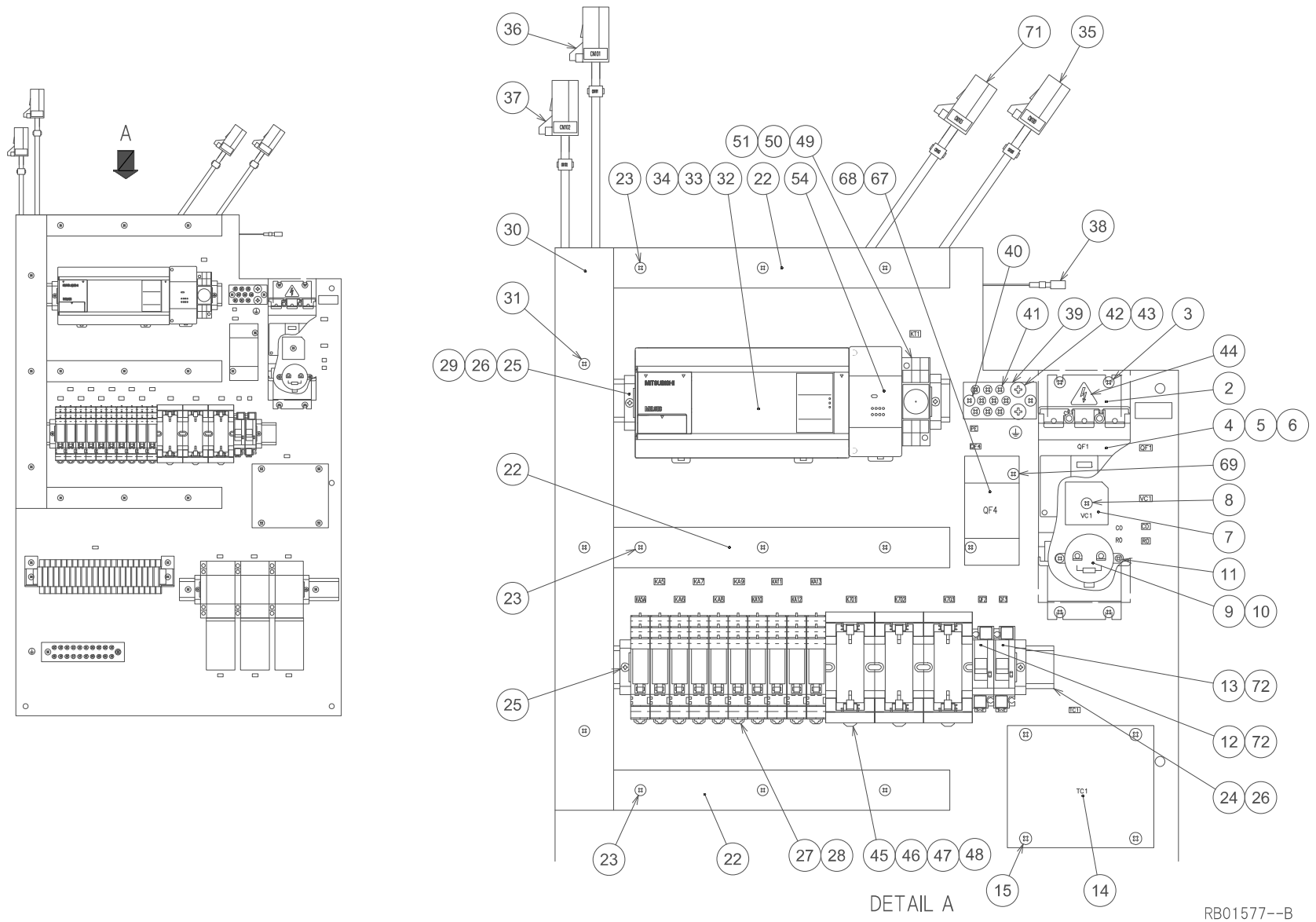

RB01577--B

Unit No. 78
 Electric EU(3)-2/2 <Panel Arrangement>

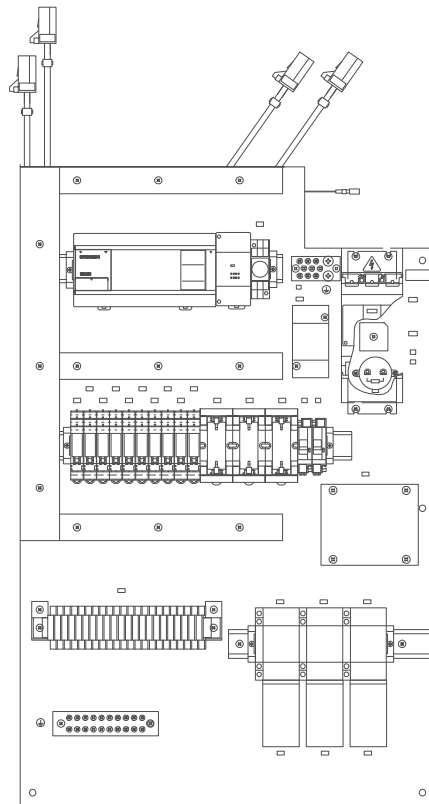

↑
B

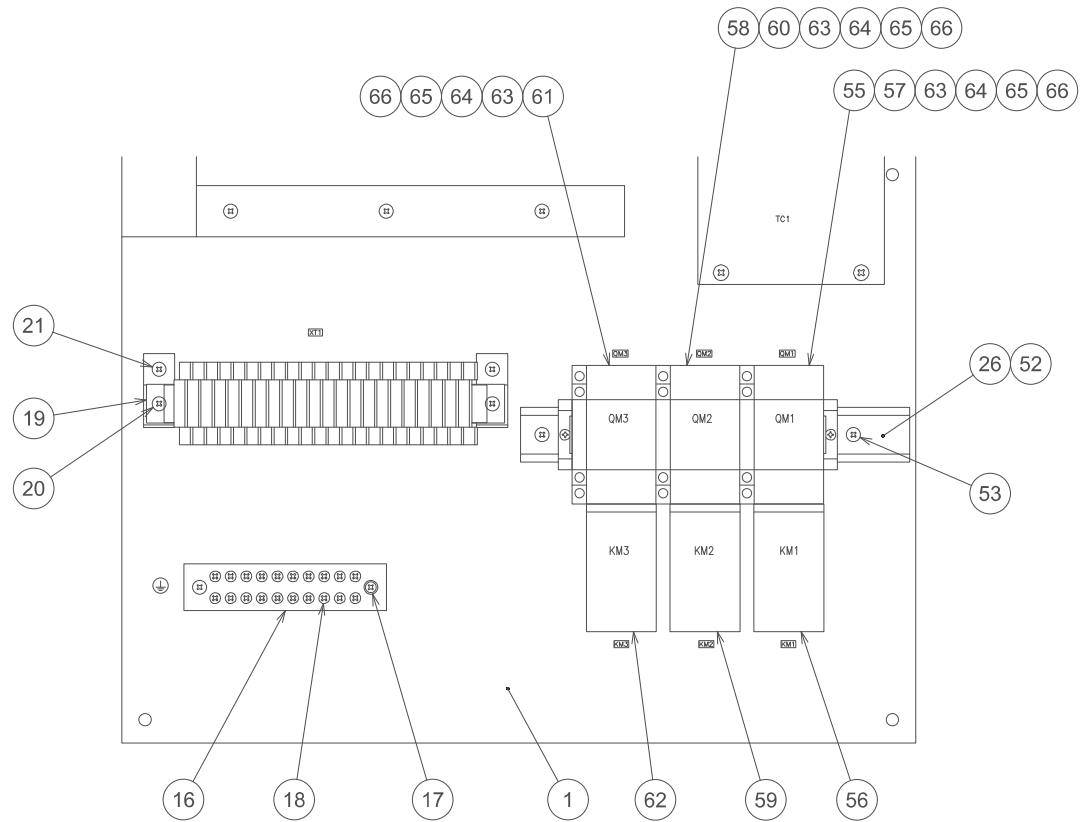

DETAIL B

RB01577--B

Unit No. 78
Electric EU(3)

Index	Code	Parts Name	Drawing No.	Type	Maker	Q'ty	Note
1	10300832	Control Panel	RB00781--C			1	
2	10300833	Breaker Bracket	RB00782--C			1	
3	10589252	Sems Pan Head Screw	P334200013	M4X10(Spring/Polished Round)	JIS	4	
4	10300187	Low Voltage Breaker	P812008026	NF32-SV-3P-30A	MITSUBISHI	1	QF1
5	10300194	Accessory (Low Voltage Breaker)	P812098064	F-05SV	MITSUBISHI	1	
6	10300195	Accessory (Low Voltage Breaker)	P812098065	TCL-05SV3	MITSUBISHI	1	
7	10300207	Rectifier	P840068014	KBPC35-10	SUMGLE	1	VC1
8	10589252	Sems Pan Head Screw	P334200013	M4X10(Spring/Polished Round)	JIS	1	
9	10300211	Aluminum Capacitor	P840108041	50V10000Micro Farad	HWAKAI	1	C0
10	10300212	Resistor	P841128056	RS2W(5.1 kOhm)	YCX	1	R0
11	10589250	Sems Pan Head Screw	P334200010	M3X10(Spring/Polished Round)	JIS	2	
12	10300196	Low Voltage Breaker	P812128227	CP31FS/2D	FUJI Electric	1	QF2
13	10300197	Low Voltage Breaker	P812128280	CP31FS/15D	FUJI Electric	1	QF3
14	10300180	Transformer	P772008054	JBK5-400	JUCHE	1	TC1
15	10380975	Sems Pan Head Screw	P334200047	M5X12(Spring/Polished Round)	JIS	4	
16	10300834	Ground Bar	RB00783--A			1	
17	10380683	Sems Pan Head Screw	P334200034	M4X16(Spring/Polished Round)	JIS	2	
18	10380682	Sems Pan Head Screw	P334200032	M4X6(Spring/Polished Round)	JIS	20	
19	10301128	Terminal Block ASSY	RB0251501B			1	XT1

Unit No. 78
Electric EU(3)

Index	Code	Parts Name	Drawing No.	Type	Maker	Q'ty	Note
20	10380683	Sems Pan Head Screw	P334200034	M4X16(Spring/Polished Round)	JIS	4	
21	10301117	Tilting Attachment	RB0160003-	(Conform to) BP23-2S		2	
22	10300224	Duct for Wiring	P869509272	GW-33100(L=275)	GIANTLOK	3	
23	10589252	Sems Pan Head Screw	P334200013	M4X10(Spring/Polished Round)	JIS	9	
24	10300218	Terminal Base	P864038172	FH-1007(L=360)	FEHUA	1	
25	10589252	Sems Pan Head Screw	P334200013	M4X10(Spring/Polished Round)	JIS	6	
26	10337281	Terminal Parts	P864052008	BNL6	IDEC	6	
27	10589483	Control Relay	P800002075	G2R-1-SND-DC24V	OMRON	10	KA5A,KA5-KA13
28	10589484	Accessory for Control Relay	P800082015	P2RF-05-E	OMRON	10	
29	10301314	Terminal Base	P864038173	FH-1007(L=275)	FEHUA	1	
30	10300225	Duct for Wiring	P869509274	GW-48100(L=460)	OLEANDER	1	
31	10589252	Sems Pan Head Screw	P334200013	M4X10(Spring/Polished Round)	JIS	3	
32	10428836	Programmable Controller	P767406003	FX1N-60MR-ES/UL	mitsubishi	1	KT1
33	10582249	Accessory (Program Controller)	P767486019	FX1N-EEPROM-8L	mitsubishi	1	
34	10300836	PLC Ladder	RB00785--A	HA252V12.2		1	
35	10301076	Cable CN100F	RB0154801A			1	CN100
36	10301077	Cable CN101F	RB0154802A			1	CN101
37	10301078	Cable CN102F	RB0154803A			1	CN102
38	10300214	Plug Type Terminal	P862148060	PC-2005F	NICHIFU	1	

Unit No. 78
Electric EU(3)

Index	Code	Parts Name	Drawing No.	Type	Maker	Q'ty	Note
39	10300835	Ground Bar	RB00784--A			1	PE
40	10380683	Sems Pan Head Screw	P334200034	M4X16(Spring/Polished Round)	JIS	2	
41	10380682	Sems Pan Head Screw	P334200032	M4X6(Spring/Polished Round)	JIS	9	
42	10300140	Sems Pan Head Screw	P334200084	M6X8(Spring/Polished Round)	JIS	2	
43	10300143	Washer	P336000074	6(Polished Round)T=1.0	JIS	2	
44	10301123	Charging Mark	RB0160010-	20MM		1	
45	10485349	Control Relay	P800002125	G7S-4A2B-E	OMRON	2	K701-K703
46	10485350	Control Relay	P800002126	G7S-3A3B-E	OMRON	1	K701-K703
47	10485351	Accessory for Control Relay	P800082063	P7S-14F-END	OMRON	3	
48	10301112	RC Cable	RB0155301-			1	
49	10301308	Timer	P805002025	H3Y-2-DC24V-30SEC	OMRON	1	
50	10300215	Accessory for Connector	P862188020	PYF08A	OMRON	1	
51	10301313	Accessory for Connector	P862188017	Y92H-3	OMRON	1	
52	10300217	Terminal Base	P864038171	FH-1007(L=250)	FEHUA	1	
53	10589252	Sems Pan Head Screw	P334200013	M4X10(Spring/Polished Round)	JIS	2	
54	10583723	Accessory (Program Controller)	P767486037	FX2N-8EYR-ES/UL	MITSUBISHI	1	
55	10301311	Low Voltage Breaker	P812048100	GV2-ME166	Schneider Electric	1	QM1
56	10579225	Magnet Contactor	P810008012	LC1-D12K7	Schneider Electric	1	KM1
57	10300184	Accessory for Contactor	P810018016	LAD-N31	Schneider Electric	1	

Unit No. 78
Electric EU(3)

Index	Code	Parts Name	Drawing No.	Type	Maker	Q'ty	Note
58	10589731	Low Voltage Breaker	P812048086	GV2-ME086	Schneider Electric	1	QM2
59	10579316	Magnet Contactor	P810008013	LC1-D09K7	Schneider Electric	1	KM2
60	10300183	Accessory for Contactor	P810018014	LAD-N20	Schneider Electric	1	
61	10589498	Low Voltage Breaker	P812048090	GV2-ME046	Schneider Electric	1	QM3
62	10579316	Magnet Contactor	P810008013	LC1-D09K7	Schneider Electric	1	KM3
63	10579229	Accessory for Contactor	P810018004	GV2-AF3	Schneider Electric	3	
64	10301116	Spark Killer	RB0160002-	(Conform to) SKVB104120		3	
65	10300210	Varistor	P840078056	TUR20D112K	JOCOL	9	
66	10579228	Accessory (Low Voltage Breaker)	P812098024	GV-AN11	Schneider Electric	3	
67	10300192	Low Voltage Breaker	P812048093	GV2-ME076	Schneider Electric	1	QF4
68	10300193	Accessory (Low Voltage Breaker)	P812098040	GV2-AF02	Schneider Electric	1	
69	10589252	Sems Pan Head Screw	P334200013	M4X10(Spring/Polished Round)	JIS	2	
70	10301079	Name Plate	RB0154804A			1	List Only
71	10301080	Cable CN103F	RB0154805-			1	CN103
72	10589507	Accessory (Low Voltage Breaker)	P812194011	CP-T4 (Terminal Cover)	FUJI Electric	4	

Unit No. 79
 Electric EU(4) <Control Panel>

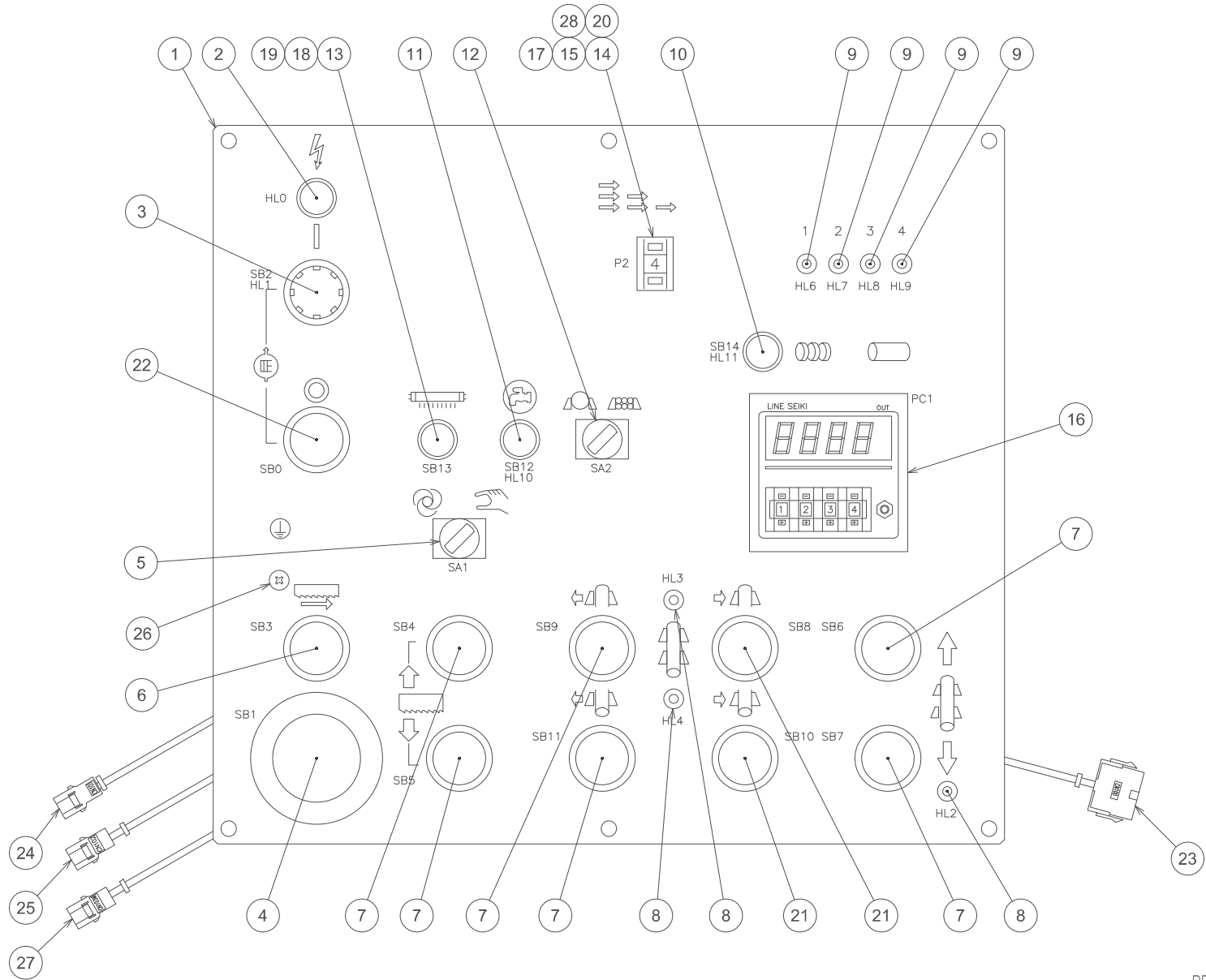

RB00778--C

Unit No. 79
Electric EU(4)

Index	Code	Parts Name	Drawing No.	Type	Maker	Q'ty	Note
1	10300837	Name Plate	RB00786--C			1	
2	10300213	Indicator Apparatus	P843024023	AH165-ZWH3	FUJI Electric	1	HL0
3	10579339	Illuminated Pushbutton	P822084031	AR22F0L-10H3W	FUJI Electric	1	SB2,HL1
4	10300199	Push Button Switch	P821084115	AR22V0R-01R	FUJI Electric	1	SB1
5	10337159	Key Select Switch	P820004027	AH165-P2B11	FUJI Electric	1	SA1
6	10579341	Push Button Switch	P821084154	AR22G2R-20W	FUJI Electric	1	SB3
7	10589510	Push Button Switch	P821084080	AR22F0R-10W	FUJI Electric	6	SB4-SB7,SB9,SB11
8	10583452	Indicator Apparatus	P843188016	DB24-89WUS	MARUYASU DENGYO	3	HL2,HL3,HL4
9	10583452	Indicator Apparatus	P843188016	DB24-89WUS	MARUYASU DENGYO	4	HL6-HL9
10	10300204	Illuminated Pushbutton	P822064076	AH165-L5W11E3	FUJI Electric	1	SB14,HL11
11	10300205	Illuminated Pushbutton	P822064077	AH165-L5W11H3	FUJI Electric	1	SB12,HL10
12	10337159	Key Select Switch	P820004027	AH165-P2B11	FUJI Electric	1	SA2
13	10337521	Push Button Switch	P821064009	AH165-E5W22	FUJI Electric	1	SB13
14	10380727	Key Select Switch	P820022002	A7BS-206-S-1	OMRON	1	P2
15	10380728	Accessory for Rotary Switch	P820082002	A7B-C(Connector)	OMRON	1	
16	10300103	Electronic Counter	7720235---	MD-144M-509	LINE SEIKI	1	PC1
17	10380870	Accessory for Rotary Switch	P820082001	A7B-M-1(Setting Plate)	OMRON	1	
18	10300208	Varistor	P840078053	TUR20D271K	JOCOL	1	
19	10301116	Spark Killer	RB0160002-	(Conform to) SKVB104120		1	

Unit No. 79
Electric EU(4)

Index	Code	Parts Name	Drawing No.	Type	Maker	Q'ty	Note
20	10300838	Counter Cover	RB00787---			1	
21	10300200	Push Button Switch	P821084195	AR22G2R-10W	FUJI Electric	2	SB8,SB10
22	10300198	Push Button Switch	P821084081	AR22F0R-01B	FUJI Electric	1	SB0
23	10300826	Cable CN100M	RB0077801A			1	CN100
24	10300827	Cable CN101M	RB0077802A			1	
25	10300828	Cable CN102M	RB0077803A			1	
26	10589252	Sems Pan Head Screw	P334200013	M4X10(Spring/Polished Round)	JIS	1	
27	10300829	Cable CN103M	RB0077804-			1	
28	10300150	Cable Band	P381058169	AB100	Tyton	2	

Unit No. 80
 Electric AS(1) <Cable>

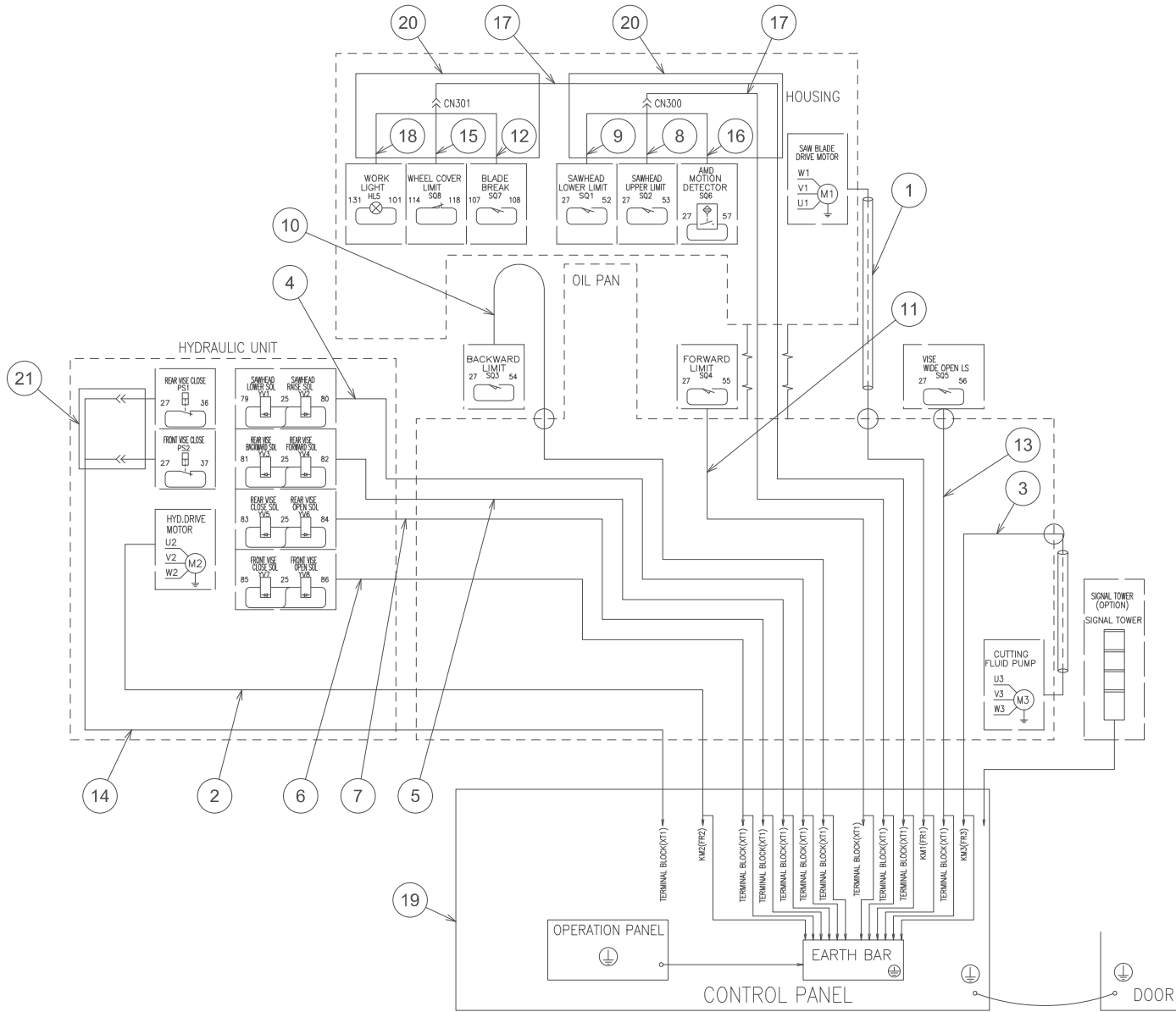

RB02511--C

Unit No. 80
Electric AS(1)

Index	Code	Parts Name	Drawing No.	Type	Maker	Q'ty	Note
1	10301332	Saw Blade Motor Cable	RB0153801A			1	
2	10301333	Hydraulic Motor Cable	RB0153802A			1	
3	10301334	Cutting Fluid Pump Motor Cable	RB0153803A			1	
4	10301337	Rase/Lower SOL Cable	RB0156906A			1	
5	10301338	Forward/Backward SOL Cable	RB0156907A			1	
6	10301339	Front Vise SOL Cable	RB0156908A			1	
7	10301340	Rear Vise SOL Cable	RB0156909A			1	
8	10301341	Sawhead Upper Limit LS Cable	RB0156911A			1	
9	10301342	Lower Limit LS Cable	RB0156912A			1	
10	10301343	Backward Limit LS Cable	RB0156913A			1	
11	10301344	Forward Limit LS Cable	RB0156914A			1	
12	10301345	Blade Break LS Cable	RB0156915A			1	
13	10301346	Sawhead Upper End Limit LS Cable	RB0156916A			1	
14	10301102	Front/Rear Vise Close LS Cable	RB0155117C			1	
15	10301541	Cover Open Limit Switch Cable	RB0251718B			1	
16	10301348	AMD Motion Detector Cable	RB0156920B			1	
17	10301542	Housing Junction Cable	RB0251721B			1	
18	10301351	Working Light Cable	RB0156923A			1	
19	10301538	Control Panel	RB0251140A			1	

Unit No. 80
Electric AS(1)

Index	Code	Parts Name	Drawing No.	Type	Maker	Q'ty	Note
20	10301118	Vinyl Tube	RB0160005-	D50XL400(T=0.5)		2	
21	10301124	Vinyl Tube	RB0160011-	D50XL200(T=0.5)		2	

Unit No. 81
 Electric AS(2)-1/2 <Electrical Enclosure>

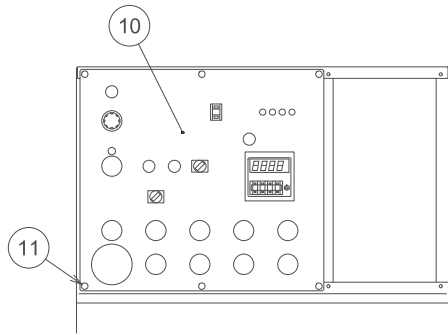

VIEW A

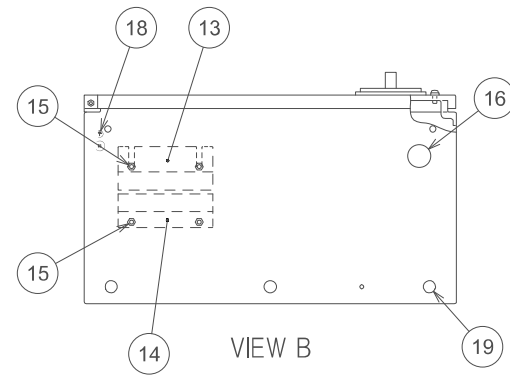
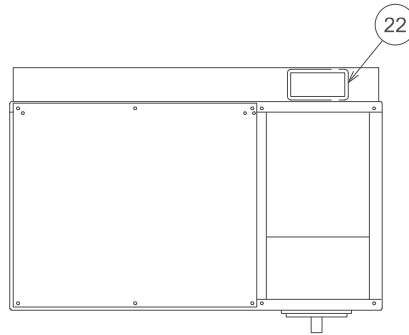

VIEW B

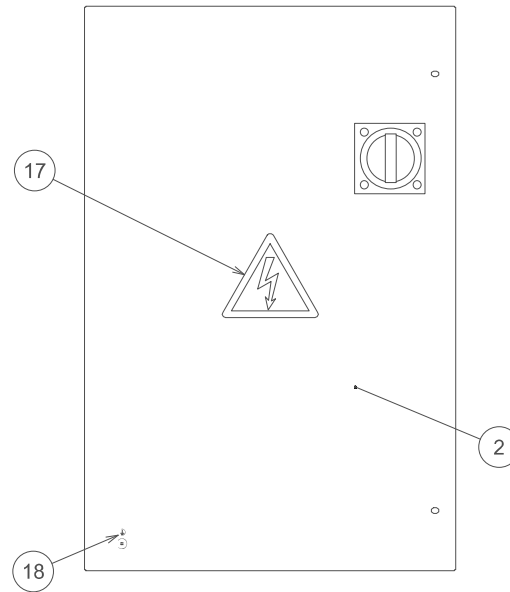
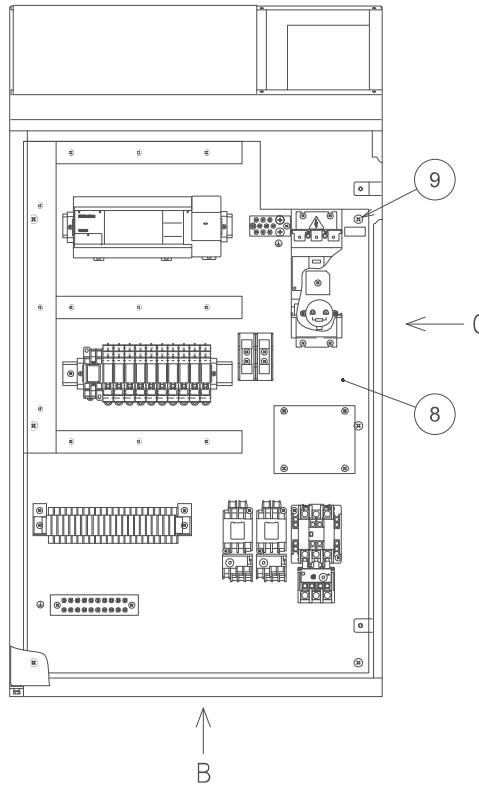
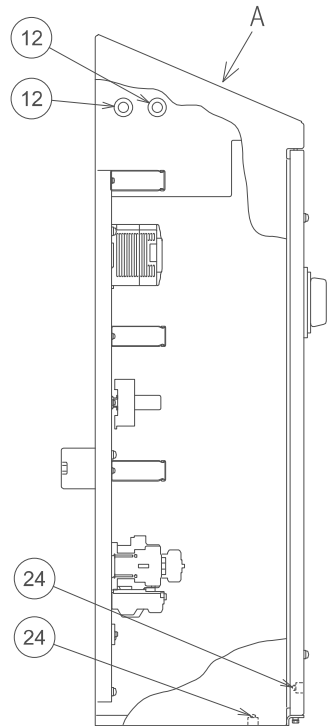

RB01532--B

Unit No. 81
Electric AS(2)-2/2 <Electrical Enclosure>

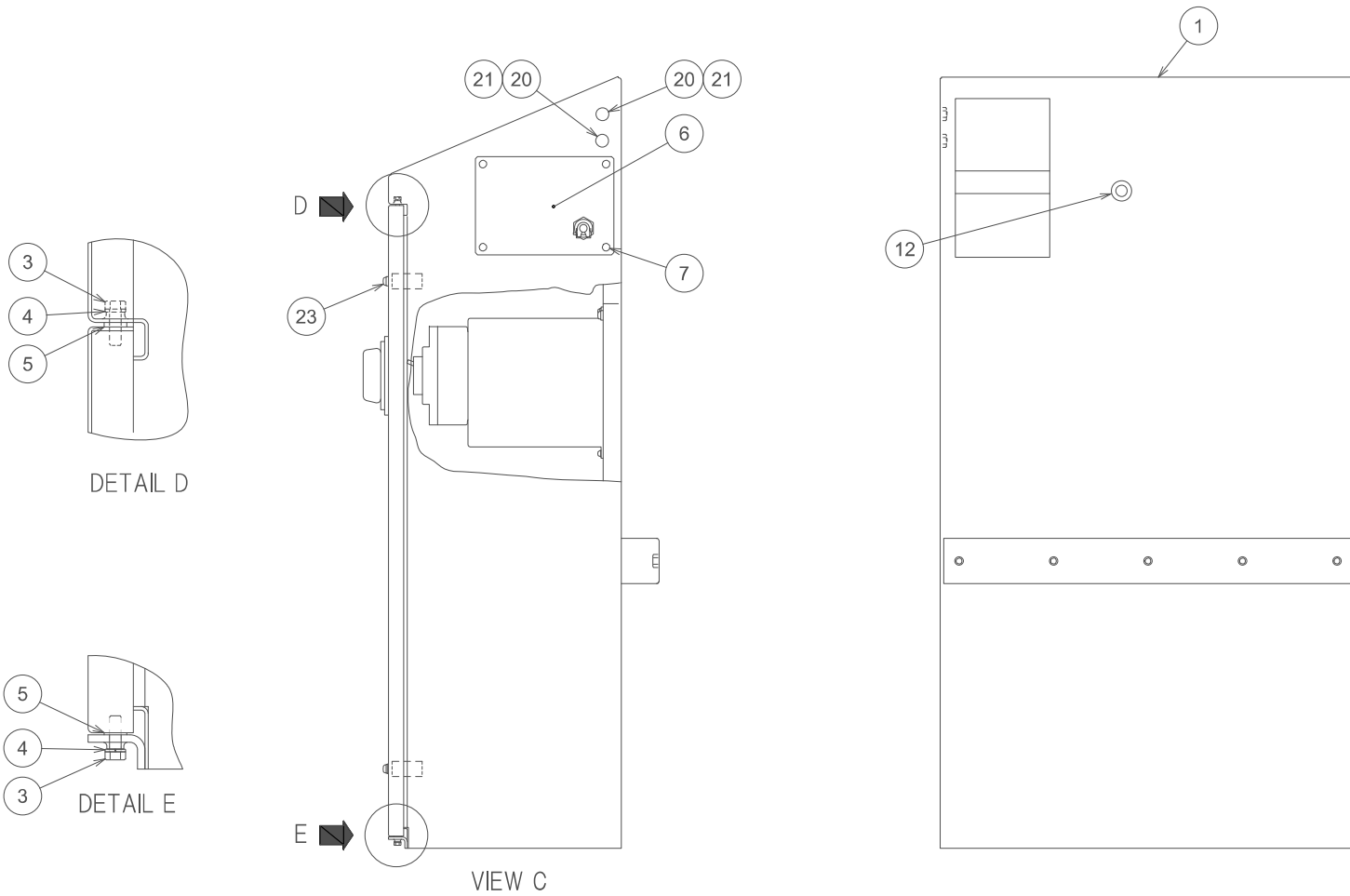

RB01532--B

Unit No. 81
Electric AS(2)

Index	Code	Parts Name	Drawing No.	Type	Maker	Q'ty	Note
1	10300821	Control Box	RB00774--C			1	
2	10300822	Control Box Cover	RB00775--B			1	
3	10325830	Bolt	P330010005	M5X16	JIS	2	
4	10322215	Spring Washer	P336050004	5	JIS	2	
5	10323127	Washer	P336000059	5(Polished Round)	JIS	2	
6	10300824	Cover	RB00776--B			1	
7	10322224	Pan Head Screw	P334100039	M5X10	JIS	4	
8	10301357	Panel Arrangement	RB01578--B			1	
9	10325313	Pan Head Screw	P334100058	M6X16	JIS	6	
10	10300825	Control Panel	RB00778--C			1	
11	10372307	Truss Head Screw	P334130009	M5X12	JIS	6	
12	10301115	Bush for Cable	RB0160001-	D22		3	
13	10300830	Cable Retainer A	RB00779--B			1	
14	10300831	Cable Retainer B	RB00780--B			1	
15	10380944	Sems Pan Head Screw	P334200063	M6X16(Spring/Polished Round)	JIS	4	
16	10301119	CAPCON	RB0160006-	D34		1	
17	10301069	Charging Mark D	RB01517---	125MM		1	
18	10301068	Sticker (Ground)	RB01516---			1	
19	10301120	Grommet	RB0160007-	D18		1	

Unit No. 81
Electric AS(2)

Index	Code	Parts Name	Drawing No.	Type	Maker	Q'ty	Note
20	10321923	Washer	P336000006	8(Normal)	JIS	2	
21	10342325	Hex Socket Cap Screw	P330230004	M8X15		2	
22	10301121	Grommet	RB0160008-	W4XL250		1	
23	10322133	Truss Head Screw	P334130014	M6X20	JIS	2	
24	10589252	Sems Pan Head Screw	P334200013	M4X10(Spring/Polished Round)	JIS	2	

Unit No. 82
 Electric AS(3)-1/2 <Panel Arrangement>

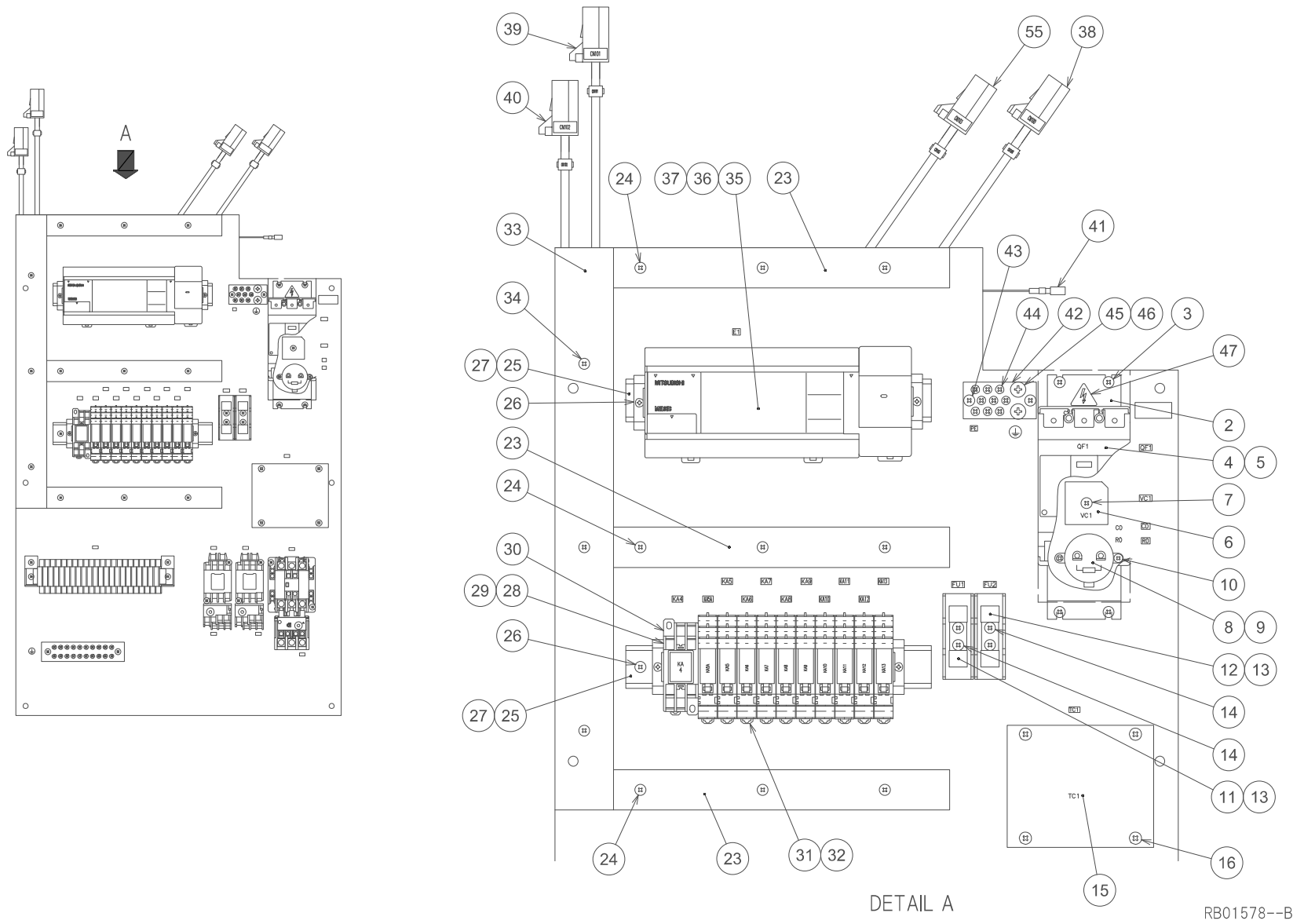

Unit No. 82
 Electric AS(3)-2/2 <Panel Arrangement>

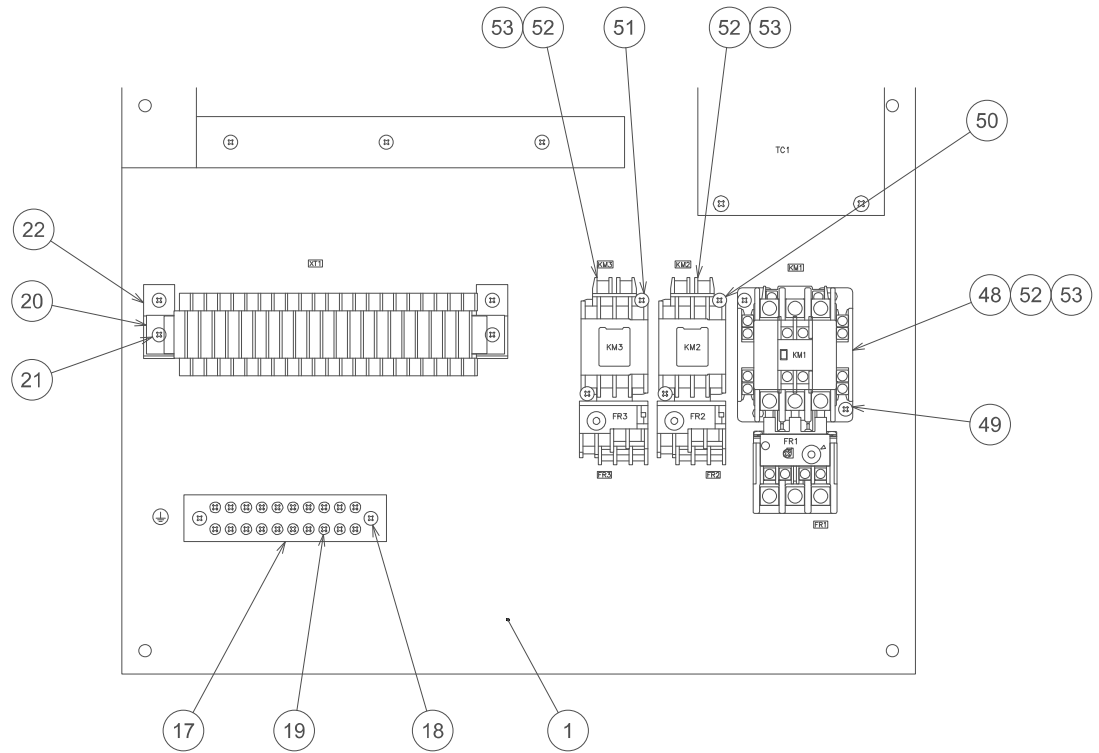
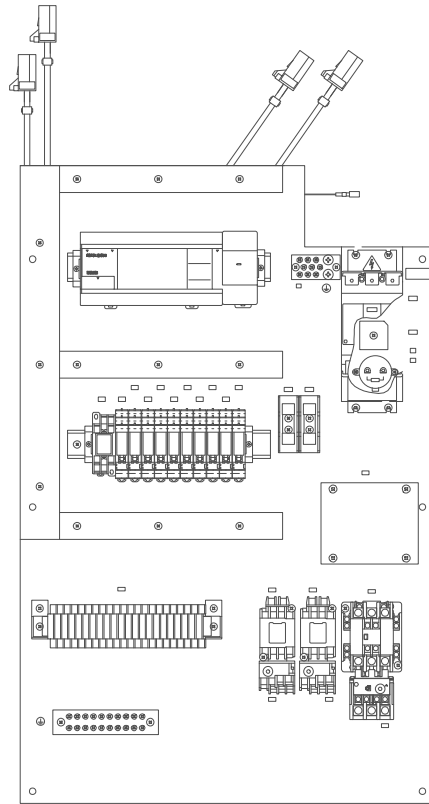

DETAIL B

RB01578--B

Unit No. 82
Electric AS(3)

Index	Code	Parts Name	Drawing No.	Type	Maker	Q'ty	Note
1	10300832	Control Panel	RB00781--C			1	
2	10300833	Breaker Bracket	RB00782--C			1	
3	10589252	Sems Pan Head Screw	P334200013	M4X10(Spring/Polished Round)	JIS	4	
4	10300194	Accessory (Low Voltage Breaker)	P812098064	F-05SV	mitsubishi	1	
5	10300195	Accessory (Low Voltage Breaker)	P812098065	TCL-05SV3	mitsubishi	1	
6	10300207	Rectifier	P840068014	KBPC35-10	SUMGLE	1	
7	10589252	Sems Pan Head Screw	P334200013	M4X10(Spring/Polished Round)	JIS	1	
8	10300211	Aluminum Capacitor	P840108041	50V10000Micro Farad	HWAKAI	1	C0
9	10300212	Resistor	P841128056	RS2W(5.1 kOhm)	YCX	1	R0
10	10589250	Sems Pan Head Screw	P334200010	M3X10(Spring/Polished Round)	JIS	2	
11	10364540	Fuse	P842064018	FCF2-3	FUJI Electric	1	FU1
12	10380702	Fuse	P842064020	FCF2-10	FUJI Electric	1	FU2
13	10382471	Fuse Holder	P842202004	F-7140	SATO PARTS	2	
14	10380683	Sems Pan Head Screw	P334200034	M4X16(Spring/Polished Round)	JIS	4	
15	10300180	Transformer	P772008054	JBK5-400	JUCHE	1	TC1
16	10380975	Sems Pan Head Screw	P334200047	M5X12(Spring/Polished Round)	JIS	4	
17	10300834	Ground Bar	RB00783--A			1	
18	10380683	Sems Pan Head Screw	P334200034	M4X16(Spring/Polished Round)	JIS	2	
19	10380682	Sems Pan Head Screw	P334200032	M4X6(Spring/Polished Round)	JIS	20	

Unit No. 82
Electric AS(3)

Index	Code	Parts Name	Drawing No.	Type	Maker	Q'ty	Note
20	10301128	Terminal Block ASSY	RB0251501B			1	
21	10380683	Sems Pan Head Screw	P334200034	M4X16(Spring/Polished Round)	JIS	4	
22	10301117	Tilting Attachment	RB0160003-	(Conform to) BP23-2S		2	
23	10300224	Duct for Wiring	P869509272	GW-33100(L=275)	GIANTLOK	3	
24	10589252	Sems Pan Head Screw	P334200013	M4X10(Spring/Polished Round)	JIS	9	
25	10300217	Terminal Base	P864038171	FH-1007(L=250)	FEHUA	2	
26	10589252	Sems Pan Head Screw	P334200013	M4X10(Spring/Polished Round)	JIS	6	
27	10337281	Terminal Parts	P864052008	BNL6	IDEC	4	
28	10300181	Control Relay	P800002091	MY2N-CR-AC100V	OMRON	1	
29	10300215	Accessory for Connector	P862188020	PYF08A	OMRON	1	
30	10349515	Accessory for Connector	P862188011	PYC-A1	OMRON	1	KA4
31	10589483	Control Relay	P800002075	G2R-1-SND-DC24V	OMRON	10	KA5A,KA5-KA13
32	10589484	Accessory for Control Relay	P800082015	P2RF-05-E	OMRON	10	
33	10300225	Duct for Wiring	P869509274	GW-48100(L=460)	OLEANDER	1	
34	10589252	Sems Pan Head Screw	P334200013	M4X10(Spring/Polished Round)	JIS	3	
35	10428836	Programmable Controller	P767406003	FX1N-60MR-ES/UL	mitsubishi	1	E1
36	10582249	Accessory (Program Controller)	P767486019	FX1N-EEPROM-8L	mitsubishi	1	
37	10300836	PLC Ladder	RB00785--A	HA252V12.2		1	
38	10301076	Cable CN100F	RB0154801A			1	CN100

Unit No. 82
Electric AS(3)

Index	Code	Parts Name	Drawing No.	Type	Maker	Q'ty	Note
39	10301077	Cable CN101F	RB0154802A			1	CN101
40	10301078	Cable CN102F	RB0154803A			1	CN102
41	10300214	Plug Type Terminal	P862148060	PC-2005F	NICHIFU	1	25
42	10300835	Ground Bar	RB00784--A			1	PE
43	10380683	Sems Pan Head Screw	P334200034	M4X16(Spring/Polished Round)	JIS	2	
44	10380682	Sems Pan Head Screw	P334200032	M4X6(Spring/Polished Round)	JIS	9	
45	10300140	Sems Pan Head Screw	P334200084	M6X8(Spring/Polished Round)	JIS	2	
46	10300143	Washer	P336000074	6(Polished Round)T=1.0	JIS	2	
47	10301123	Charging Mark	RB0160010-	20MM		1	
48	10589493	Accessory (Magnet Switch)	P810184001	SZ-A20	FUJI Electric	1	KM1,FR1
49	10380683	Sems Pan Head Screw	P334200034	M4X16(Spring/Polished Round)	JIS	2	
50	10380683	Sems Pan Head Screw	P334200034	M4X16(Spring/Polished Round)	JIS	2	
51	10380683	Sems Pan Head Screw	P334200034	M4X16(Spring/Polished Round)	JIS	2	
52	10301116	Spark Killer	RB0160002-	(Conform to) SKVB104120		3	
53	10300210	Varistor	P840078056	TUR20D112K	JOCOL	9	
54	10301079	Name Plate	RB0154804A			1	List Only/US(AC230V)/ AS(AC460V)
55	10301080	Cable CN103F	RB0154805-			1	CN103

Unit No. 83
 Electric AS(4) <Control Panel>

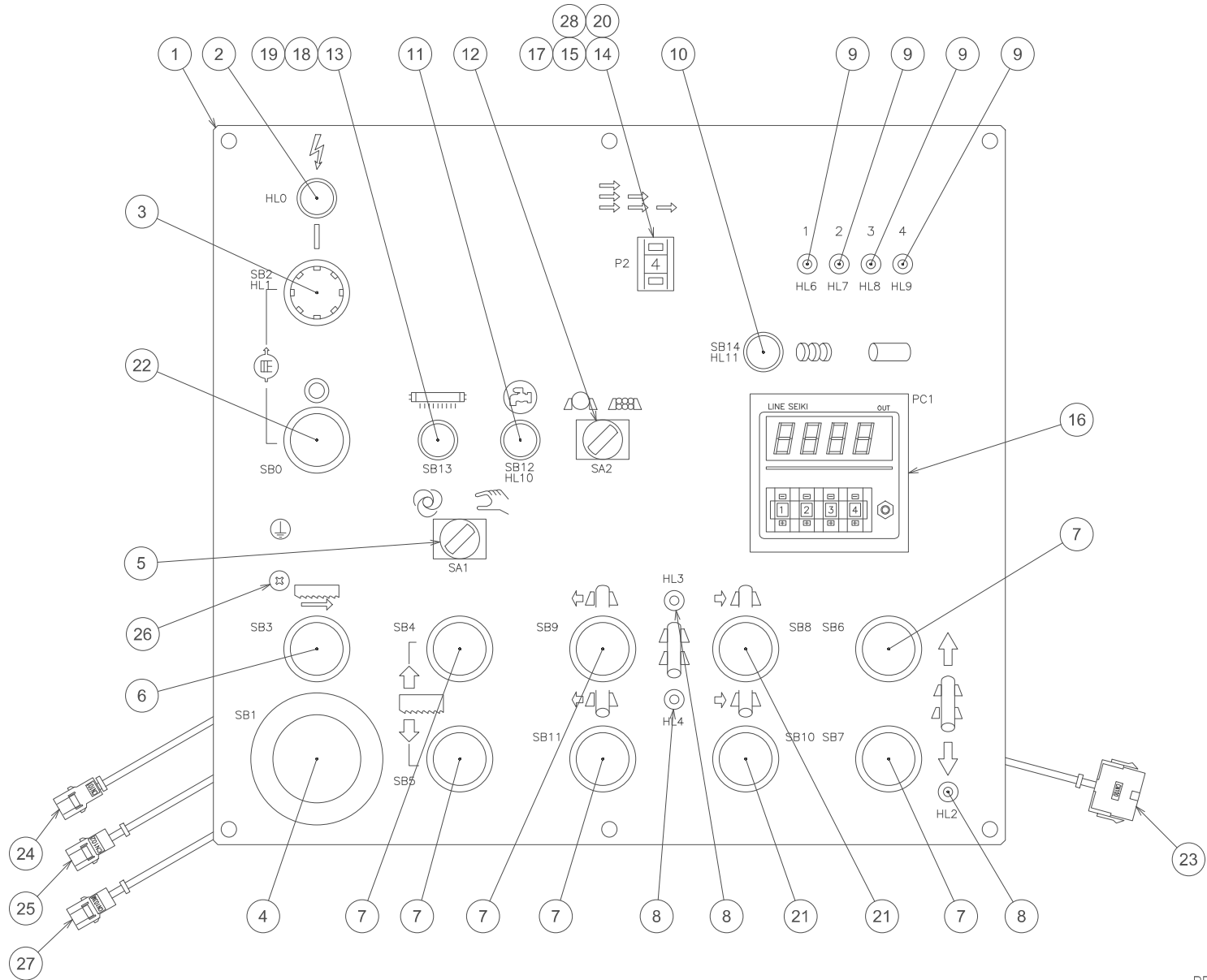

RB00778--C

Unit No. 83
Electric AS(4)

Index	Code	Parts Name	Drawing No.	Type	Maker	Q'ty	Note
1	10300837	Name Plate	RB00786--C			1	
2	10300213	Indicator Apparatus	P843024023	AH165-ZWH3	FUJI Electric	1	HL0
3	10579339	Illuminated Pushbutton	P822084031	AR22F0L-10H3W	FUJI Electric	1	SB2,HL1
4	10300199	Push Button Switch	P821084115	AR22V0R-01R	FUJI Electric	1	SB1
5	10337159	Key Select Switch	P820004027	AH165-P2B11	FUJI Electric	1	SA1
6	10579341	Push Button Switch	P821084154	AR22G2R-20W	FUJI Electric	1	SB3
7	10589510	Push Button Switch	P821084080	AR22F0R-10W	FUJI Electric	6	SB4-SB7,SB9,SB11
8	10583452	Indicator Apparatus	P843188016	DB24-89WUS	MARUYASU DENGYO	3	HL2,HL3,HL4
9	10583452	Indicator Apparatus	P843188016	DB24-89WUS	MARUYASU DENGYO	4	HL6-HL9
10	10300204	Illuminated Pushbutton	P822064076	AH165-L5W11E3	FUJI Electric	1	SB14,HL11
11	10300205	Illuminated Pushbutton	P822064077	AH165-L5W11H3	FUJI Electric	1	SB12,HL10
12	10337159	Key Select Switch	P820004027	AH165-P2B11	FUJI Electric	1	SA2
13	10337521	Push Button Switch	P821064009	AH165-E5W22	FUJI Electric	1	SB13
14	10380727	Key Select Switch	P820022002	A7BS-206-S-1	OMRON	1	P2
15	10380728	Accessory for Rotary Switch	P820082002	A7B-C(Connector)	OMRON	1	
16	10300103	Electronic Counter	7720235---	MD-144M-509	LINE SEIKI	1	PC1
17	10380870	Accessory for Rotary Switch	P820082001	A7B-M-1(Setting Plate)	OMRON	1	
18	10300208	Varistor	P840078053	TUR20D271K	JOCOL	1	
19	10301116	Spark Killer	RB0160002-	(Conform to) SKVB104120		1	

Unit No. 83
Electric AS(4)

Index	Code	Parts Name	Drawing No.	Type	Maker	Q'ty	Note
20	10300838	Counter Cover	RB00787---			1	
21	10300200	Push Button Switch	P821084195	AR22G2R-10W	FUJI Electric	2	SB8,SB10
22	10300198	Push Button Switch	P821084081	AR22F0R-01B	FUJI Electric	1	SB0
23	10300826	Cable CN100M	RB0077801A			1	CN100
24	10300827	Cable CN101M	RB0077802A			1	
25	10300828	Cable CN102M	RB0077803A			1	
26	10589252	Sems Pan Head Screw	P334200013	M4X10(Spring/Polished Round)	JIS	1	
27	10300829	Cable CN103M	RB0077804-			1	
28	10300150	Cable Band	P381058169	AB100	Tyton	2	

Unit No. 84
 Electric AS(5)-1/2 <AS Specification Component>

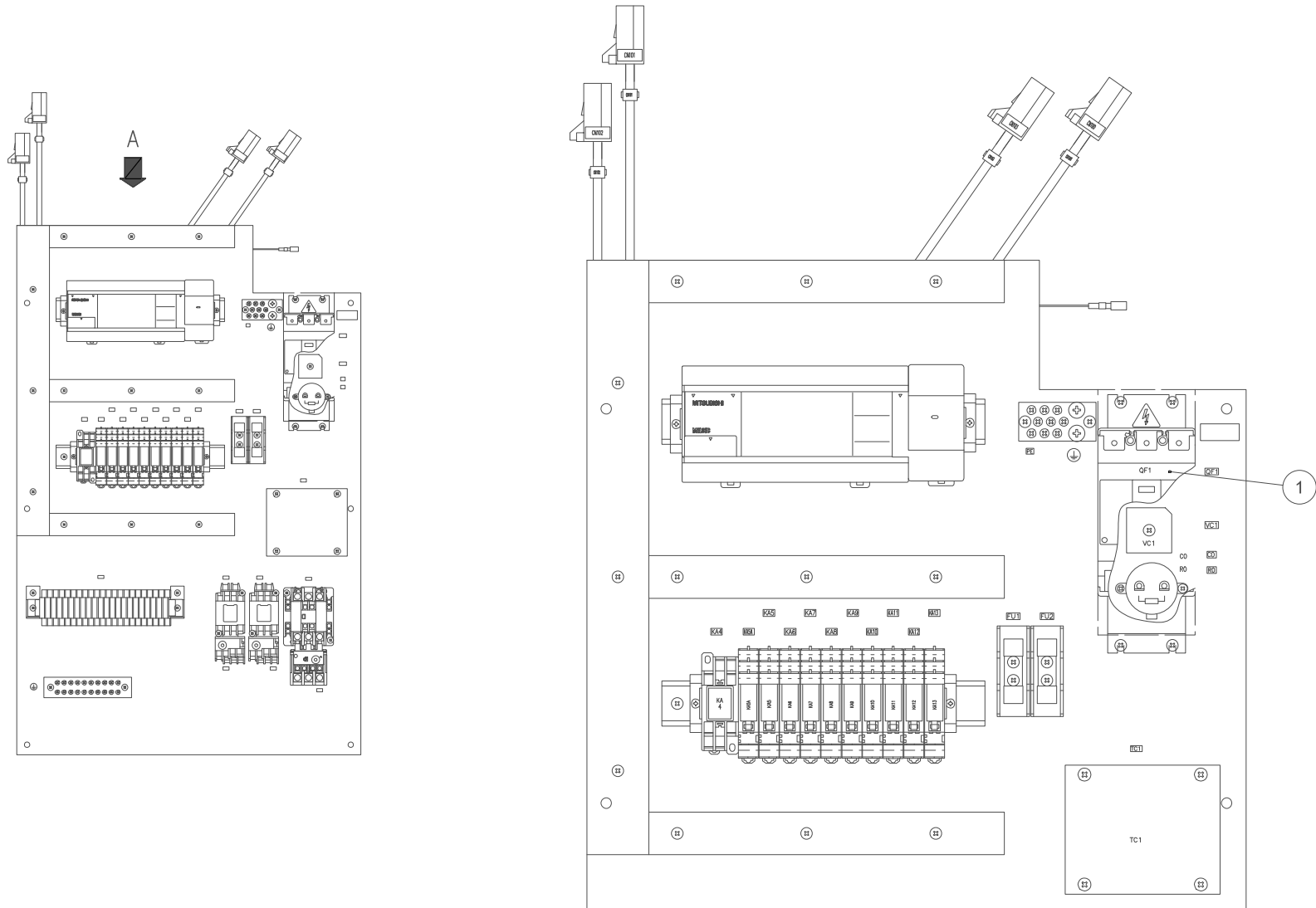

DETAIL A

RB01534---
 (RB01578--B)

Unit No. 84
 Electric AS(5)-2/2 <AS Specification Component>

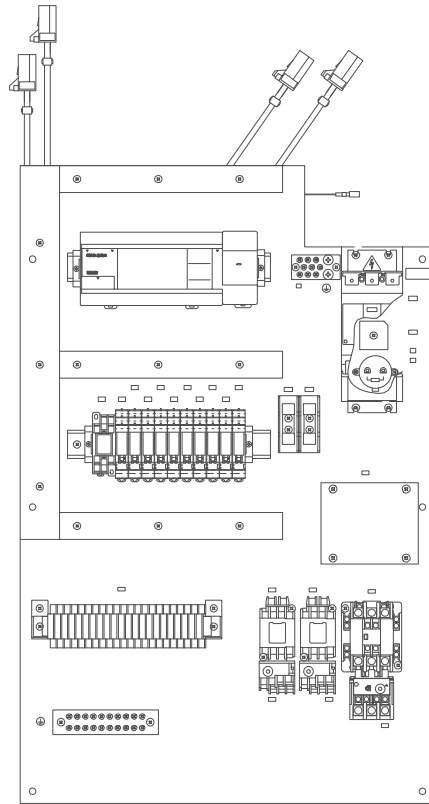

B

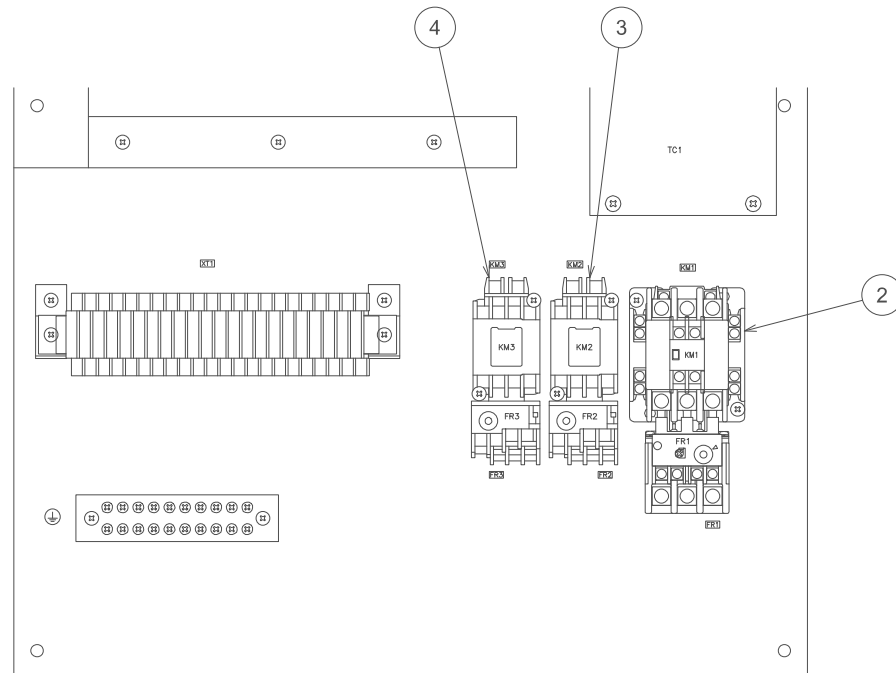

DETAIL B

RB01534---
 (RB01578--B)

Unit No. 84
 Electric AS(5)

Index	Code	Parts Name	Drawing No.	Type	Maker	Q'ty	Note
1	10300187	Low Voltage Breaker	P812008026	NF32-SV-3P-30A	MITSUBISHI	1	QF1
2	10579413	Magnet Switch	P810044147	SW-N1/3H(9A)AC100V	FUJI Electric	1	KM1,FR1
3	10579402	Magnet Switch	P810044142	SW-05/3H(2.8A)AC100V-2A	FUJI Electric	1	KM2,FR2
4	10579405	Magnet Switch	P810044137	SW-0/3H(0.36A)AC100V	FUJI Electric	1	KM3,FR3

Unit No. 85
Standard Accessory(1) <DOM>

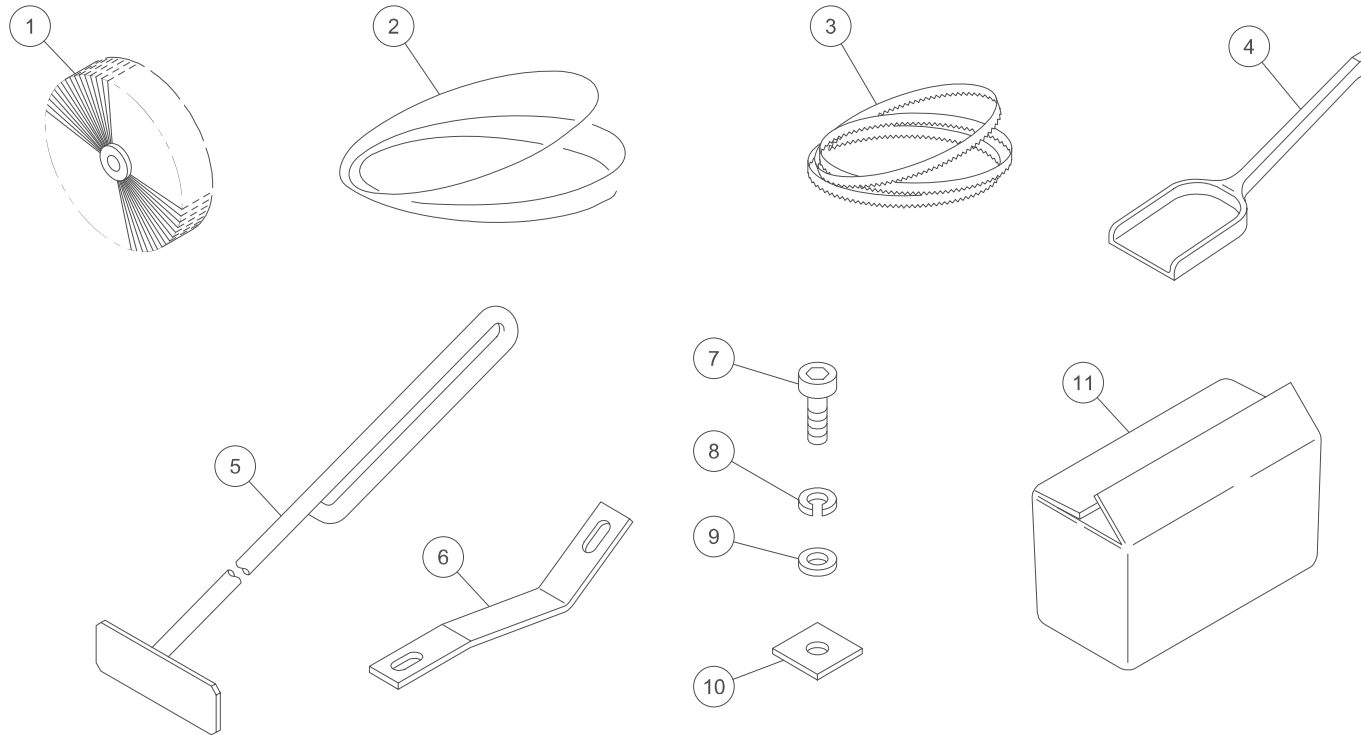

Unit No. 85

Standard Accessory(1)

Index	Code	Parts Name	Drawing No.	Type	Maker	Q'ty	Note
1	10300687	Wire Brush	RB00609---			2	
2	10311214	Polyurethane Rope	0636547 C	D4X1730L		3	
3	10301303	Band Saw Blade	P632204057	SGLB-34-1.1-4570-3/4P	AMADA	1	
4	10321201	Chip Shovel	0602631			1	
5	10365520	Chip Remover	0605565			1	
6	10345214	Shipping Bracket	1230806 A			1	
7	10341713	Hex Socket Cap Screw	P330240006	M10X20		2	
8	10001520	Spring Washer	P336050007	10	JIS	2	
9	10325021	Washer	P336000007	10(Normal)	JIS	4	
10	10345217	Fiber	1230807			2	
11	10383300	Corrugated Cardboard Box	P370600003	305X210X615		1	

Unit No. 86
Standard Accessory(2) <US,EU,AS>

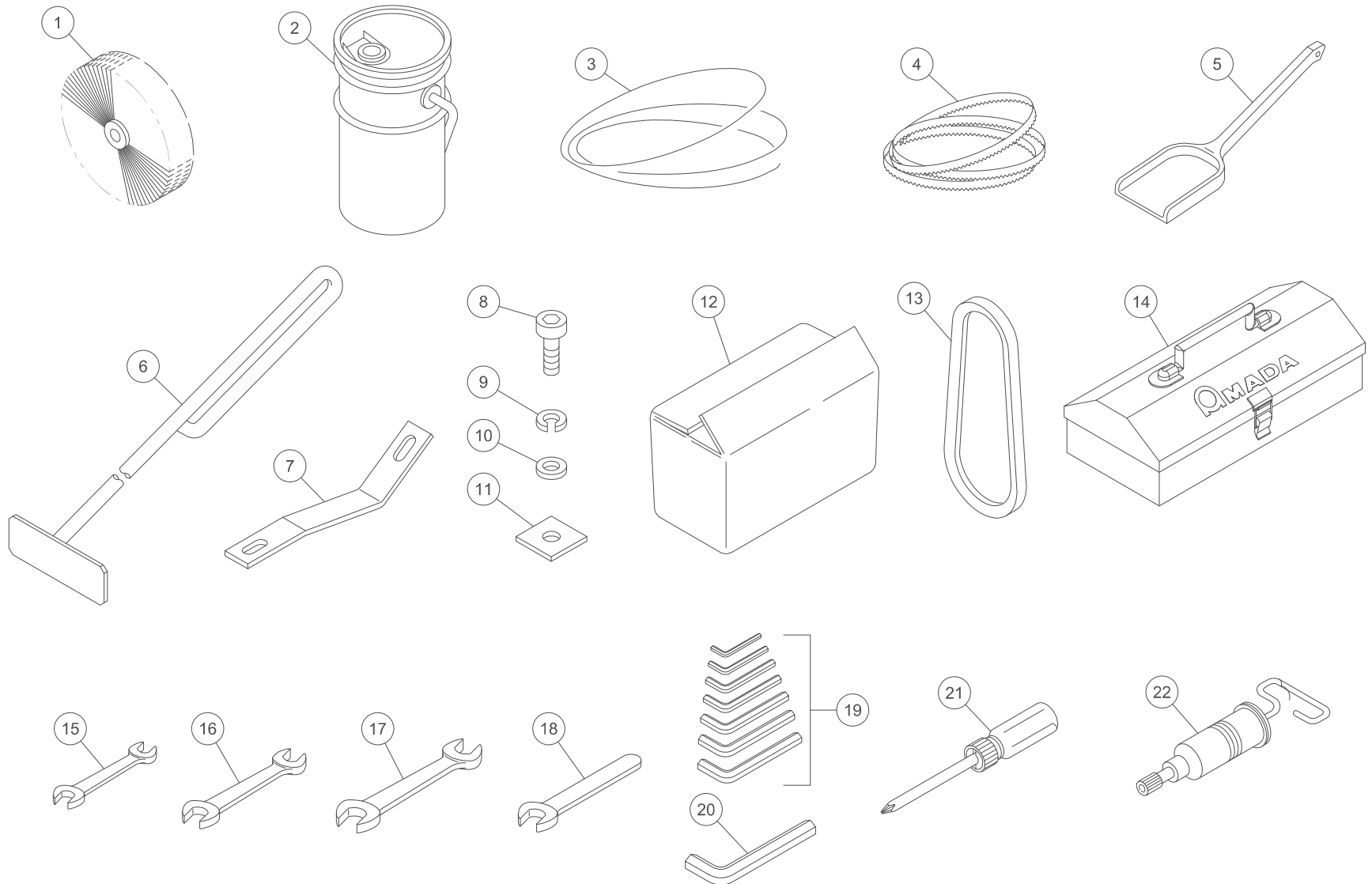

1278893--A

Unit No. 86

Standard Accessory(2)

Index	Code	Parts Name	Drawing No.	Type	Maker	Q'ty	Note
1	10300687	Wire Brush	RB00609---			3	
2	10419380	Hydraulic Oil	P238000010	ISO-VG32-40L	AMADA	1	
3	10311214	Polyurethane Rope	0636547 C	D4X1730L		3	
4	10301303	Band Saw Blade	P632204057	SGLB-34-1.1-4570-3/4P	AMADA	1	
5	10321201	Chip Shovel	0602631			1	
6	10365520	Chip Remover	0605565			1	
7	10345214	Shipping Bracket	1230806 A			1	
8	10341713	Hex Socket Cap Screw	P330240006	M10X20		2	
9	10001520	Spring Washer	P336050007	10	JIS	2	
10	10325021	Washer	P336000007	10(Normal)	JIS	4	
11	10345217	Fiber	1230807			2	
12	10383300	Corrugated Cardboard Box	P370600003	305X210X615		1	
13	10380583	V-belt	P223000016	M48		1	
14	10581225	Tool Box	7912021	350X150X65(TM-2)		1	
15	10345208	Wrench	P351010013	13X17		1	
16	10345209	Wrench	P351010010	19X22		1	
17	10345210	Wrench	P351010003	24X27		1	
18	10345211	Single Ended Wrench	P351000022	14		1	
19	10301287	Bar Wrench Set	P351040002	2.5-3-4-5-6-8-10		1	

Unit No. 86

Standard Accessory(2)

Index	Code	Parts Name	Drawing No.	Type	Maker	Q'ty	Note
20	10485309	Socket Screw Key	P351030011	14	JIS	1	
21	10485310	Screwdriver	P353000004	H2(Normal)	JIS	1	
22	10345225	Grease Gun	P359308003	KH-35	YAMADA	1	

Unit No. 87
Standard Accessory(3) <CHI>

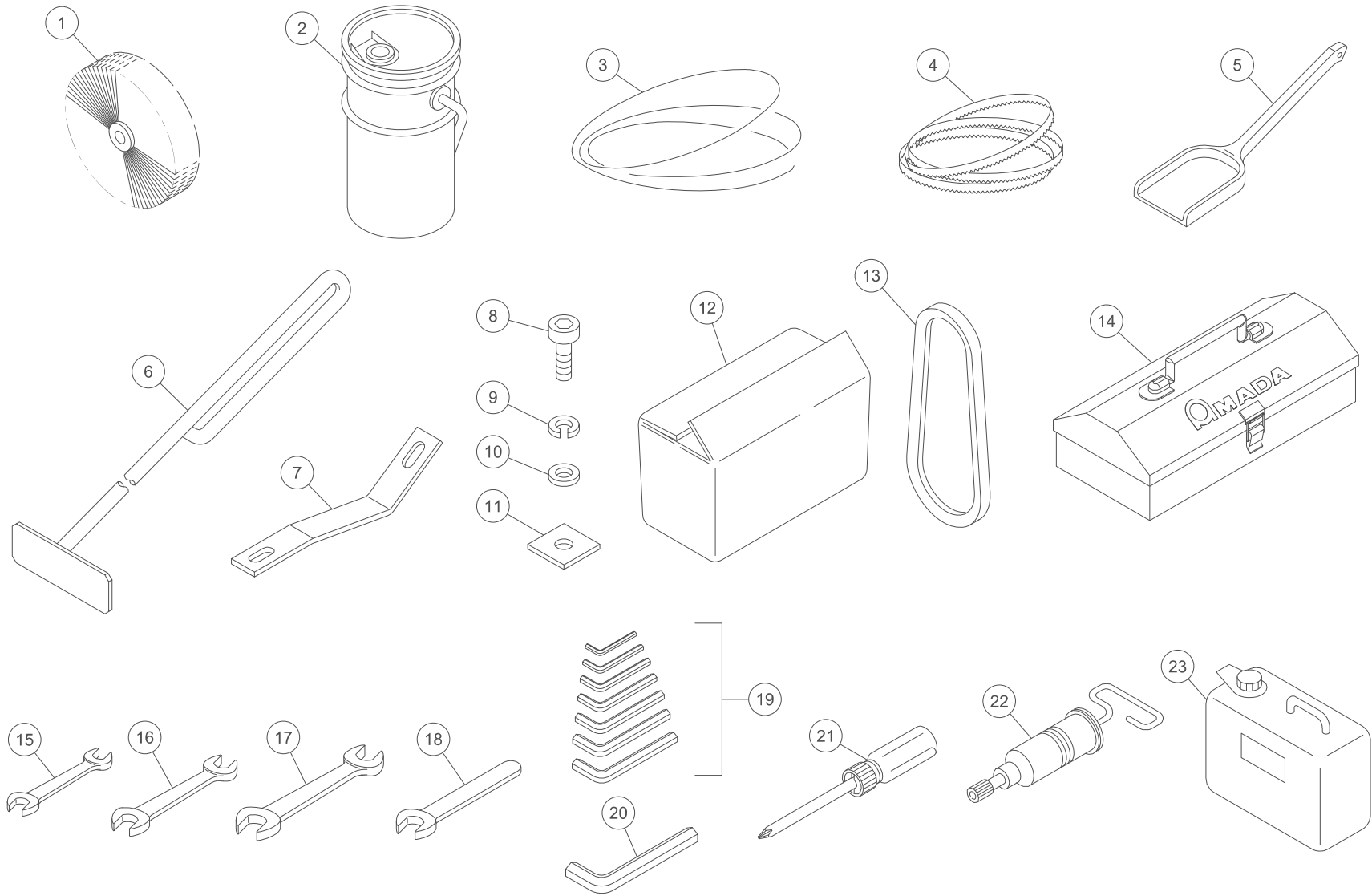

1278894---

Unit No. 87

Standard Accessory(3)

Index	Code	Parts Name	Drawing No.	Type	Maker	Q'ty	Note
1	10300687	Wire Brush	RB00609---			3	
2	10419380	Hydraulic Oil	P238000010	ISO-VG32-40L	AMADA	1	
3	10311214	Polyurethane Rope	0636547 C	D4X1730L		3	
4	10301303	Band Saw Blade	P632204057	SGLB-34-1.1-4570-3/4P	AMADA	1	
5	10321201	Chip Shovel	0602631			1	
6	10365520	Chip Remover	0605565			1	
7	10345214	Shipping Bracket	1230806 A			1	
8	10341713	Hex Socket Cap Screw	P330240006	M10X20		2	
9	10001520	Spring Washer	P336050007	10	JIS	2	
10	10325021	Washer	P336000007	10(Normal)	JIS	4	
11	10345217	Fiber	1230807			2	
12	10383300	Corrugated Cardboard Box	P370600003	305X210X615		1	
13	10380583	V-belt	P223000016	M48		1	
14	10581225	Tool Box	7912021	350X150X65(TM-2)		1	
15	10345208	Wrench	P351010013	13X17		1	
16	10345209	Wrench	P351010010	19X22		1	
17	10345210	Wrench	P351010003	24X27		1	
18	10345211	Single Ended Wrench	P351000022	14		1	
19	10301287	Bar Wrench Set	P351040002	2.5-3-4-5-6-8-10		1	

Unit No. 87

Standard Accessory(3)

Index	Code	Parts Name	Drawing No.	Type	Maker	Q'ty	Note
20	10485309	Socket Screw Key	P351030011	14	JIS	1	
21	10485310	Screwdriver	P353000004	H2(Normal)	JIS	1	
22	10345225	Grease Gun	P359308003	KH-35	YAMADA	1	
23	10301323	Cutting Fluid	RB0054039-	3L		2	

Unit No. 88
Standard Accessory(4) <HA400W>

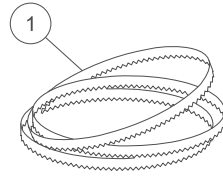

P632204013

Unit No. 88

Standard Accessory(4)

Index	Code	Parts Name	Drawing No.	Type	Maker	Q'ty	Note
1	10583730	Band Saw Blade	P632204013	SGLB41X1.3X4570X34	AMADA	1	

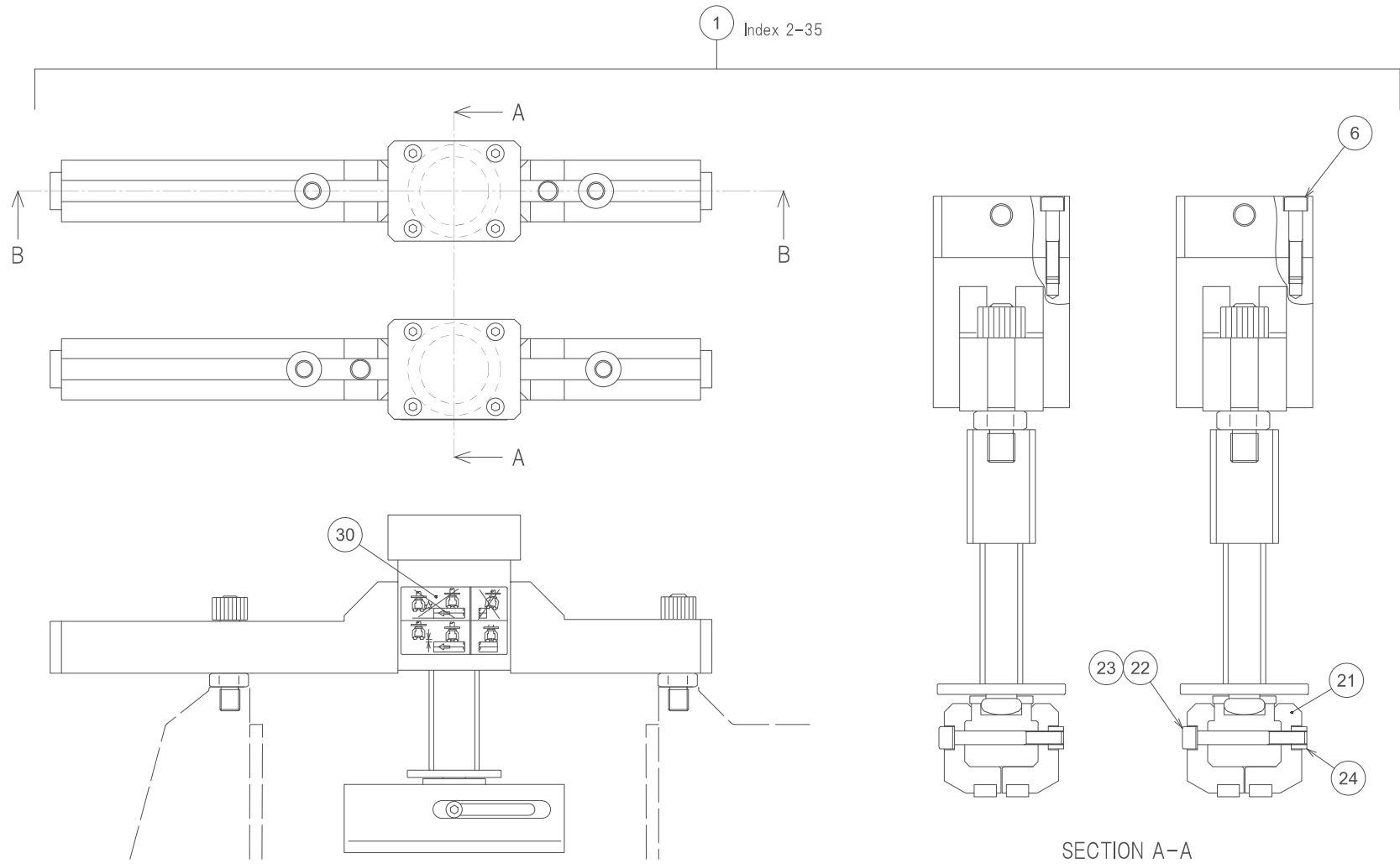

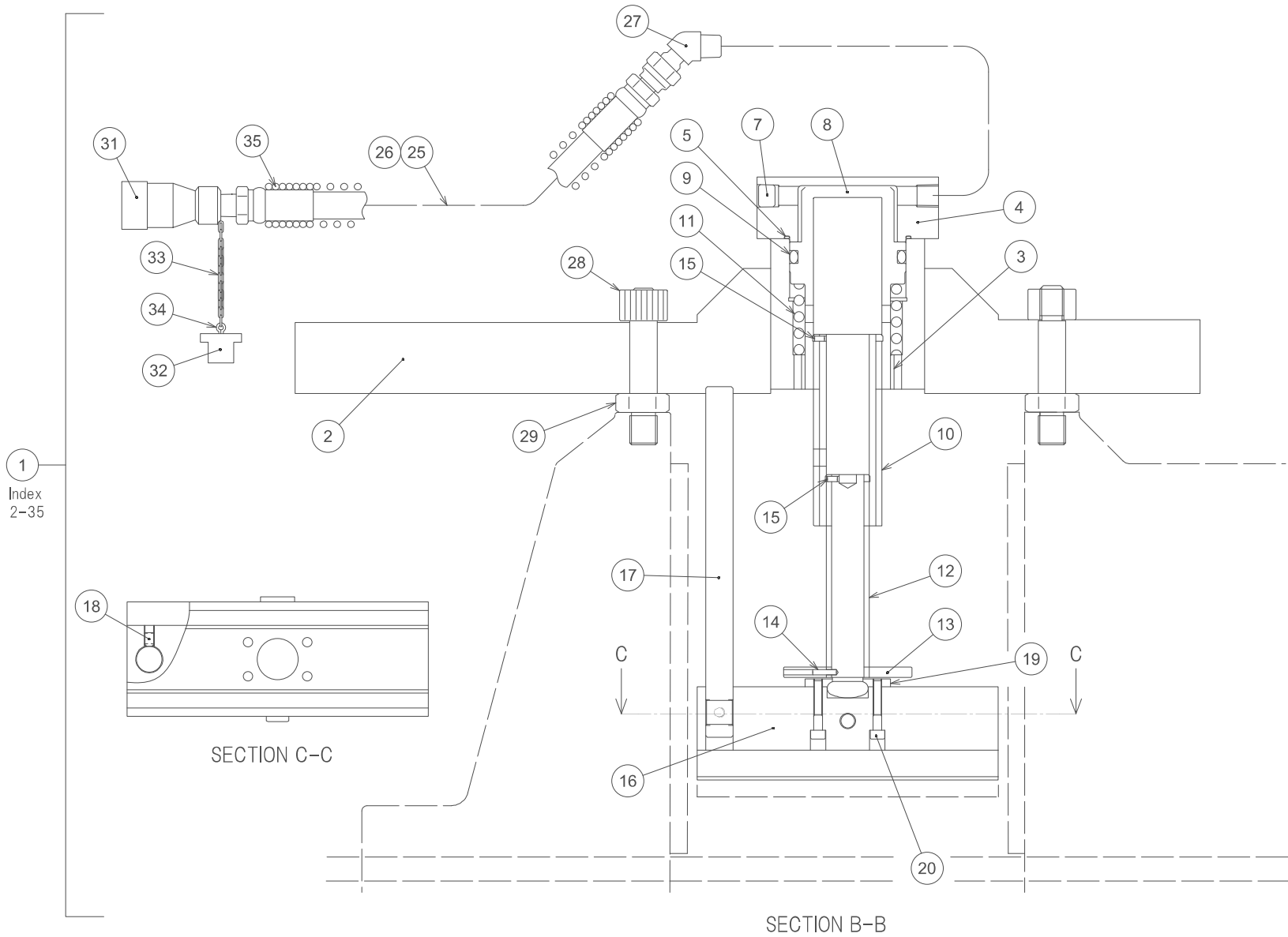

Unit No. 89

Multi-vice

Index	Code	Parts Name	Drawing No.	Type	Maker	Q'ty	Note
1	10302105	Multi-vice ASSY	SBS0137---	1238615 B, 1238617, 1280777 others		1	with Index 2-35
2	10419389	Cylinder Body	1238615 B			2	
3	10581239	Plain Bearing	P407003193	DUB5020	DAIDO METAL	2	
4	10378616	Cylinder Cap	1238616			2	
5	10339017	O Ring	P590032047	S71	NOK	2	
6	10323207	Hex Socket Cap Screw	P330230010	M8X40		8	
7	10300171	Plug for Piping	P580208021	PT-1/4		2	
8	10378617	Piston	1238617			2	
9	10380808	O Ring	P590002055	1A-P58	NOK	2	
10	10378618	Tension Rod	1238618			2	
11	10339049	Spring	1280781 A			2	
12	10000635	Clamper Screw	1238619			2	
13	10000713	Handle	1280777			2	
14	10331237	Spring Pin	P337030013	3X14AW	JIS	2	
15	10339125	Spring Pin	P337030009	3X6AW	JIS	4	
16	10000733	Clamper	1230877			2	
17	10378620	Guide Bar	1238620			2	
18	10322120	Socket Set Screw	P330590018	M6X8(Dimple Type)	JIS	2	
19	10000925	Clamping Plate	1230878			4	

Unit No. 89

Multi-vise

Index	Code	Parts Name	Drawing No.	Type	Maker	Q'ty	Note
20	10328335	Hex Socket Cap Screw	P330210011	M5X30		8	
21	10000806	Urethane Clamper	1230879			4	
22	10339118	Hex Socket Cap Screw	P330230015	M8X65		2	
23	10589279	Conical Spring Washer	P336165002	CDW-8H	HHK	2	
24	10339063	Square Nut	1230880			2	
25	10339006	Hydraulic Hose	1280786			1	
26	10339007	Hydraulic Hose	1280787 A			1	
27	10380807	Hose Adapter	P589227018	045-4-4	NITTA MOORE	2	
28	10000818	Multi-vise Stand	1230883			4	
29	10000913	Domed Cap Nut	0018038 A			4	
30	10338954	Name Plate	1230888			1	
31	10589430	Quick Connect Joint	P589026081	2S-BSBM	NITTO KOHKI	2	
32	10001010	Rubber Plug	0636994			2	
33	10300613	Chain	RB0054035-	L=150		2	
34	10329430	Split Pin	P337000034	3.2X22(Mild Steel)	JIS	2	
35	10375463	Cable Band	P381058035	SKB-2M	KITAGAWA	2	

Unit No. 90
Vise Pressure Control Valve(1)

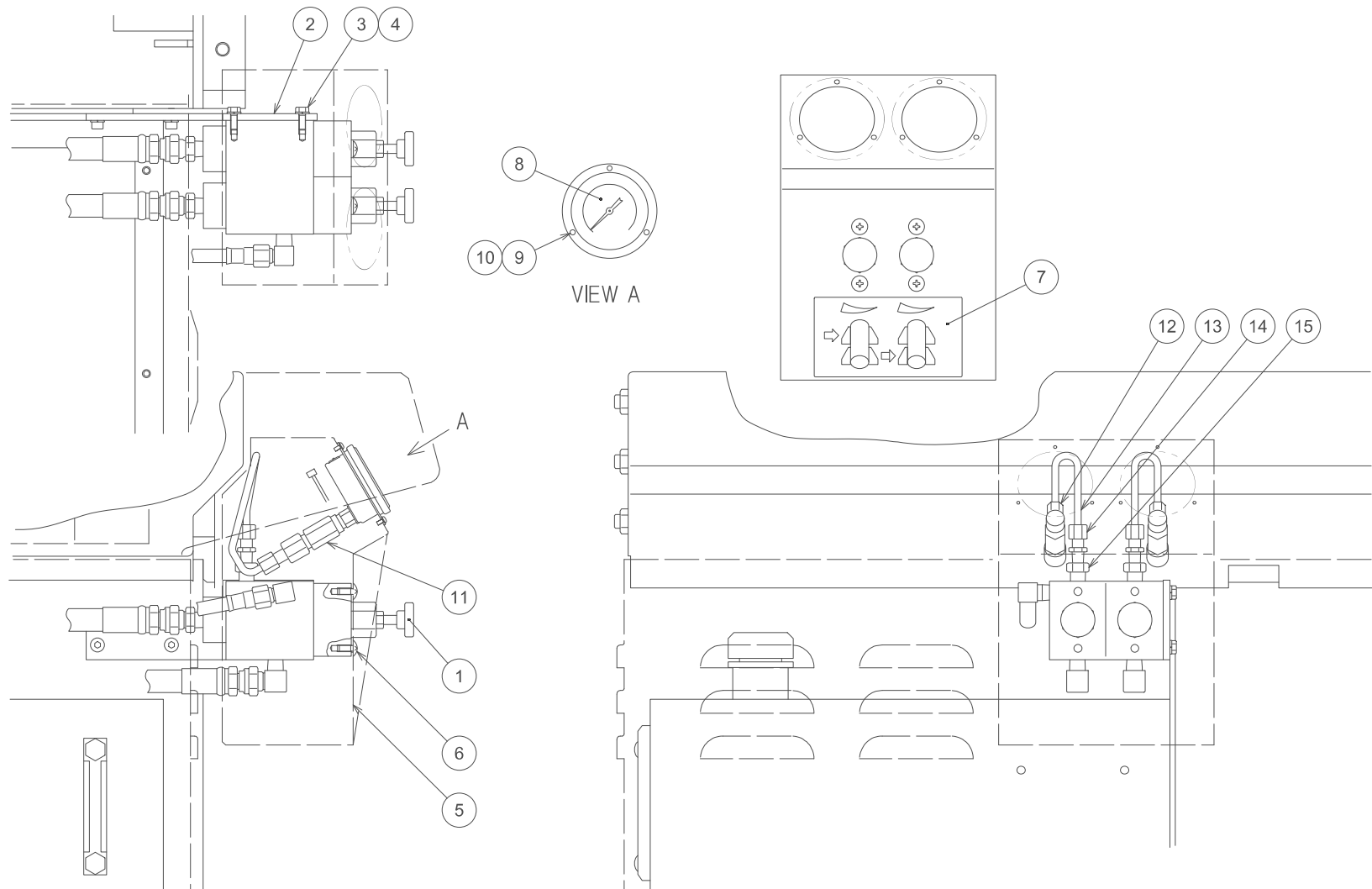

Unit No. 90

Vise Pressure Control Valve(1)

Index	Code	Parts Name	Drawing No.	Type	Maker	Q'ty	Note
1	10389958	Vise Pressure Control Valve	7922858 A	YV-1221-3	YUATSU SEIKO	1	
2	10301145	Vise Pressure Control Valve Bracket	1108719---			1	
3	10323204	Hex Socket Cap Screw	P330220007	M6X16	JIS	4	
4	10310351	Spring Washer	P336050005	6	JIS	4	
5	10301144	Vise Pressure Control Valve Cover	1108717--B			1	
6	10340019	Truss Head Screw	P334130012	M6X12	JIS	4	
7	10340608	Name Plate	1230899			1	
8	10301277	Pressure Gauge	7922943 B	OPGDFT-G1/4-60X10MPA	ASK	2	
9	10328312	Pan Head Screw	P334100003	M3X6	JIS	6	
10	10338205	Spring Washer	P336050002	3	JIS	6	
11	10328959	Gauge Damper	P549018003	SA-100-2	ASK	2	
12	10485332	Bite Type Pipe Fitting	P585520003	KSP-1/4X6-B	IHARA Science	2	
13	10380810	Copper Pipe	QZZ036563	D4XD6XL150		1	
14	10301300	Bite Type Pipe Fitting	P585538014	KC6-R1/8-B	IHARA Science	2	
15	10416703	Bush for Piping	P580010001	1/4X1/8	JIS	2	

Unit No. 91

Vise Pressure Control Valve(2) <Plugging Plate>

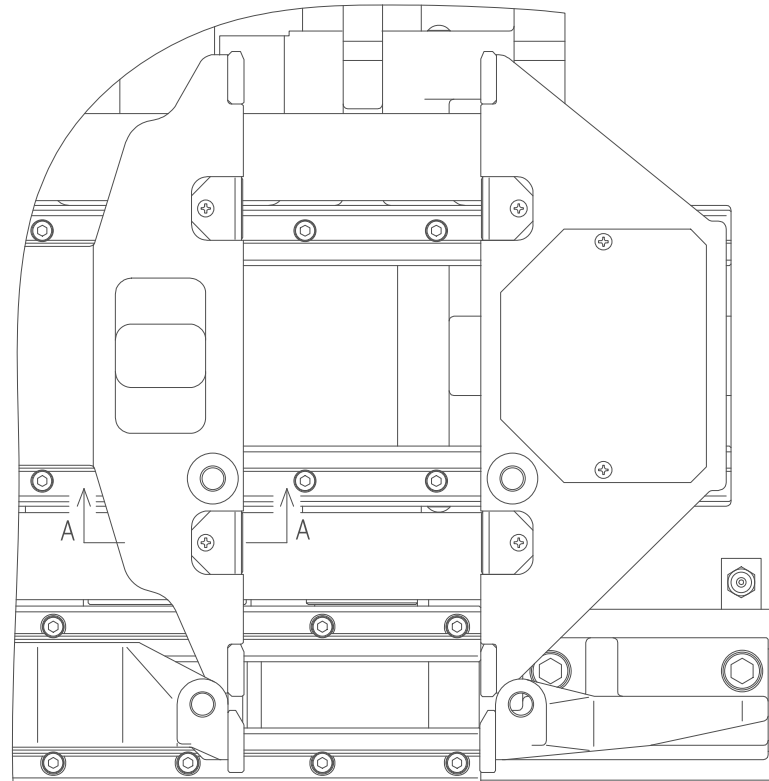
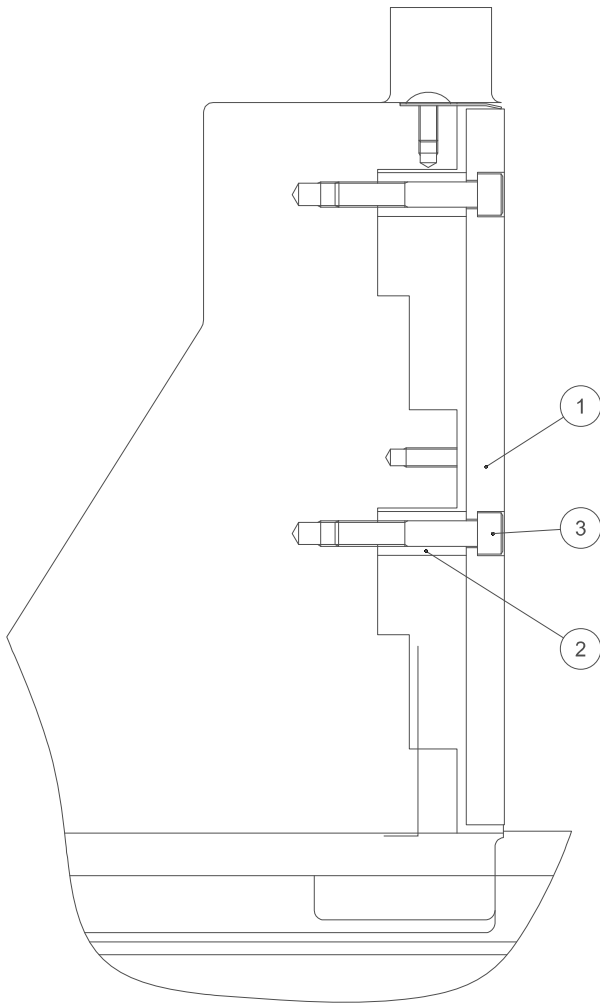

1238676

Unit No. 91

Vise Pressure Control Valve(2)

Index	Code	Parts Name	Drawing No.	Type	Maker	Q'ty	Note
1	10380830	Plate	1238506 A			4	
2	10380831	Collar	1238507 A			8	
3	10323203	Hex Socket Cap Screw	P330230011	M8X45		8	

Unit No. 92

Vise Pressure Control Valve(3) <Piping>

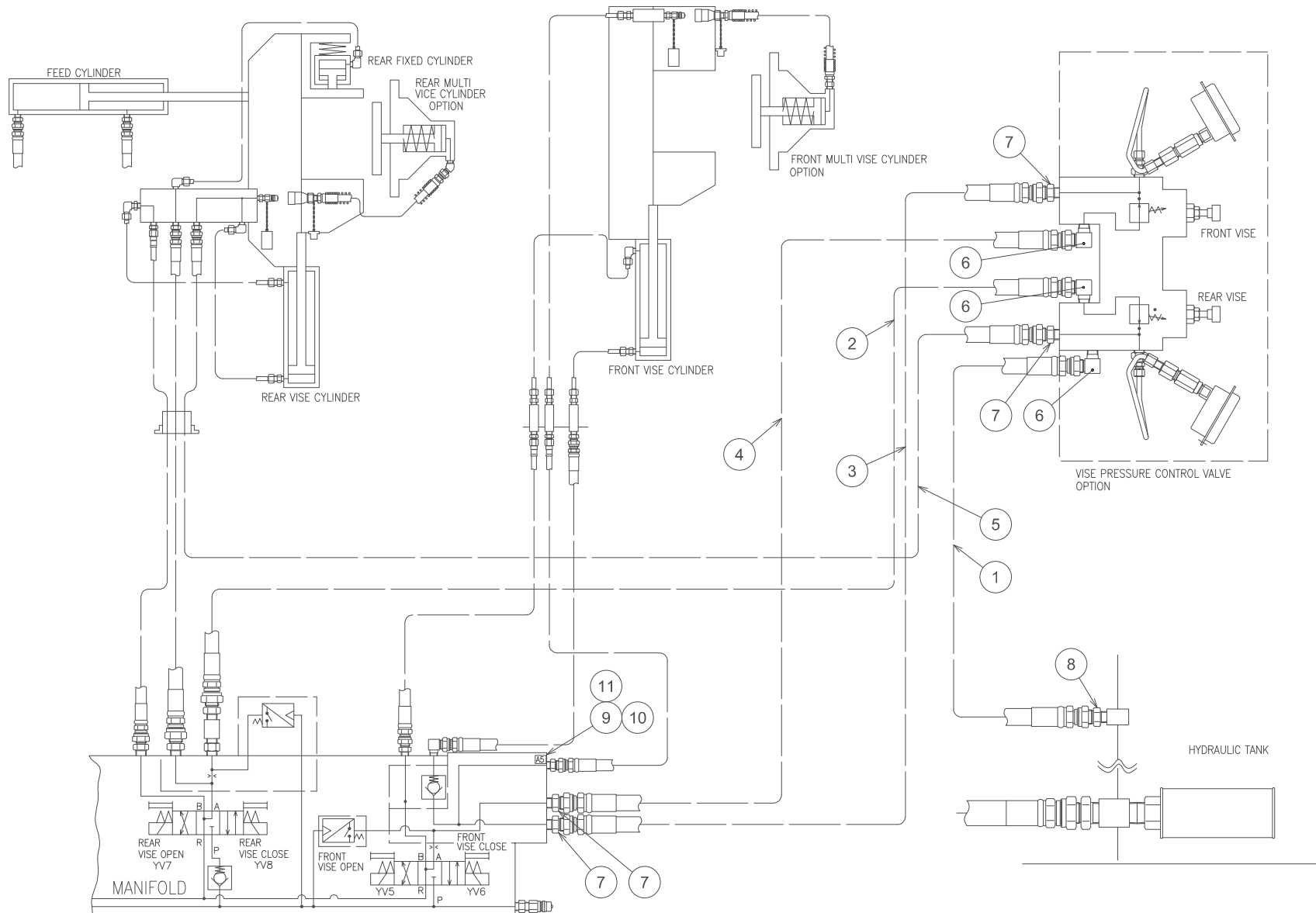

1278817--A

Unit No. 92

Vise Pressure Control Valve(3)

Index	Code	Parts Name	Drawing No.	Type	Maker	Q'ty	Note
1	10380814	Hydraulic Hose	1238661	3/8X1070		1	
2	10380815	Hydraulic Hose	1238662	3/8X1500		1	
3	10380816	Hydraulic Hose	1238663	3/8X900		1	
4	10380817	Hydraulic Hose	1238664	3/8X870		1	
5	10583736	Hydraulic Hose	1230323	3/8X2800		1	
6	10301126	Elbow	RB0198903-	PT1/4-PF3/8		3	
7	10300597	Male-Male Adapter	RB0054013B	PT1/4-PF3/8		4	
8	10300598	Male-Male Adapter	RB0054014A	PT3/8-PF3/8		1	
9	10376779	Vise Pressure Control Valve Sub Plate	1108739 A			1	
10	10314519	O Ring	P590000007	P9		4	
11	10372068	Hex Socket Cap Screw	P330210021	M5X130	MOURI	4	

Unit No. 93
Saw Blade Breakage Detection LS

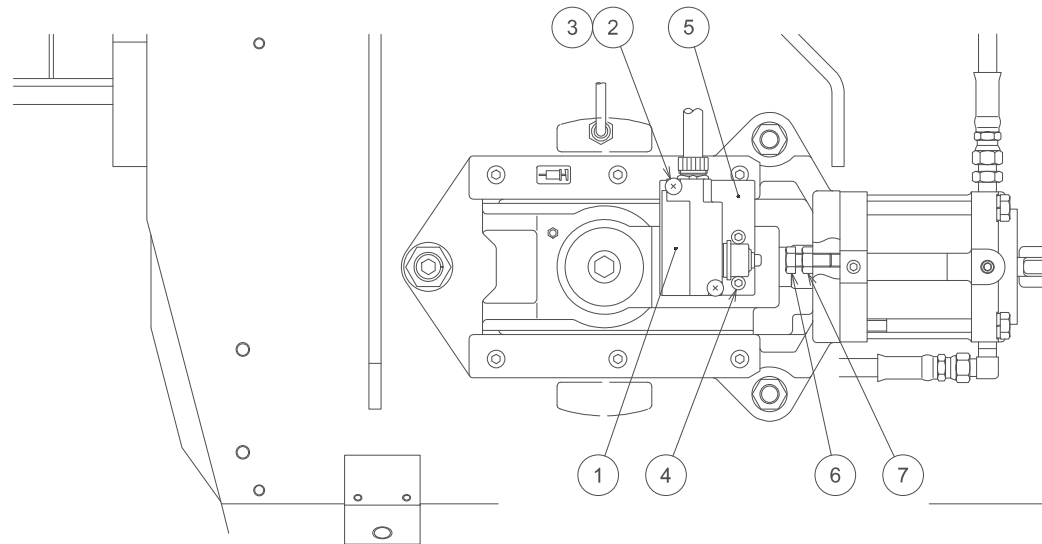
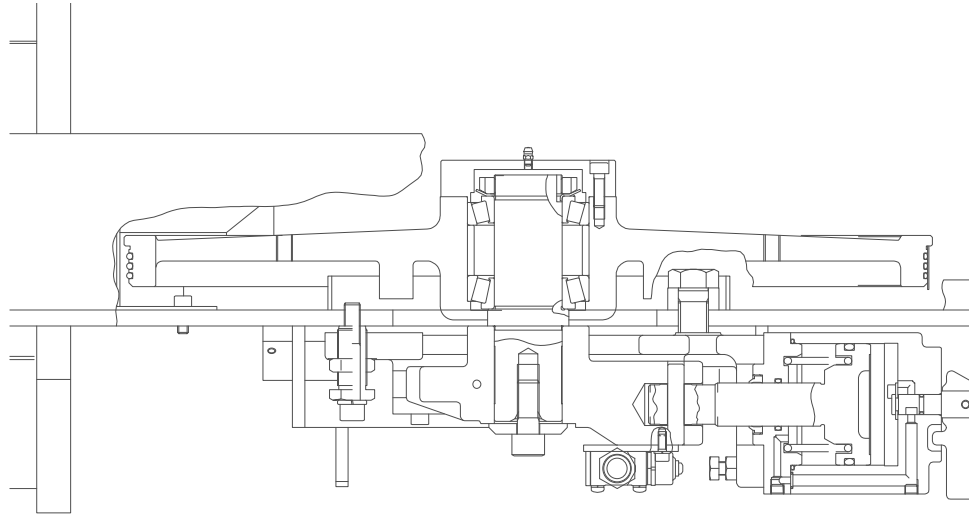

1278880---
(1278780--B)

Unit No. 93

Saw Blade Breakage Detection LS

Index	Code	Parts Name	Drawing No.	Type	Maker	Q'ty	Note
1	10318541	Limit Switch	P828012030	ZV2-N-2	OMRON	1	
2	10377210	Pan Head Screw	P334100046	M5X30	JIS	2	
3	10322215	Spring Washer	P336050004	5	JIS	2	
4	10343434	Hex Socket Cap Screw	P330220005	M6X14	MOURI	2	
5	10419512	LS Setting Plate	1109075 B			1	
6	10325724	Bolt	P330040033	M10X30(All-thread)	MOURI	1	
7	10427991	Nut	P332000006	M10	JIS	1	

Unit No. 94
Roller Stand

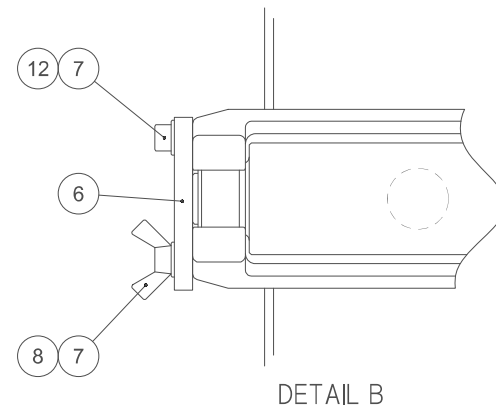
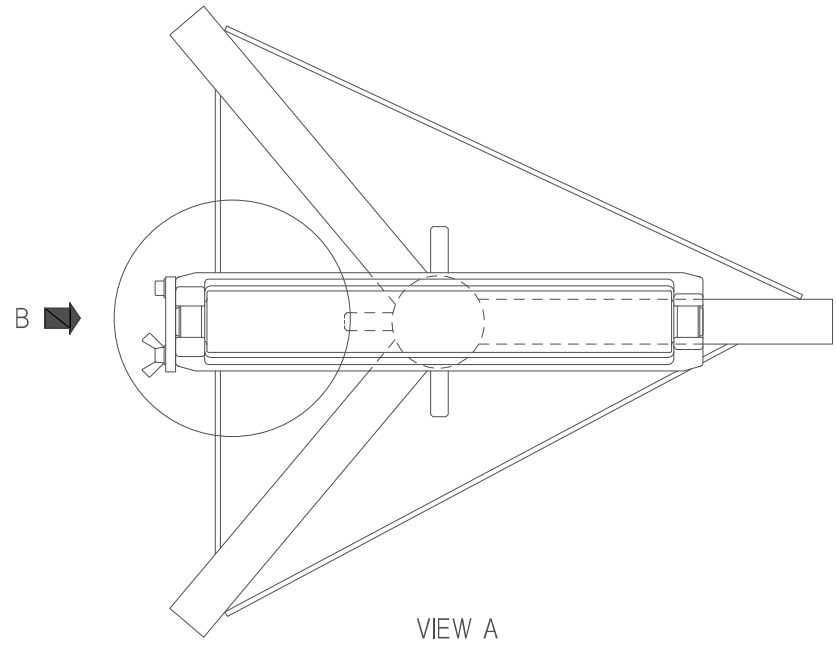
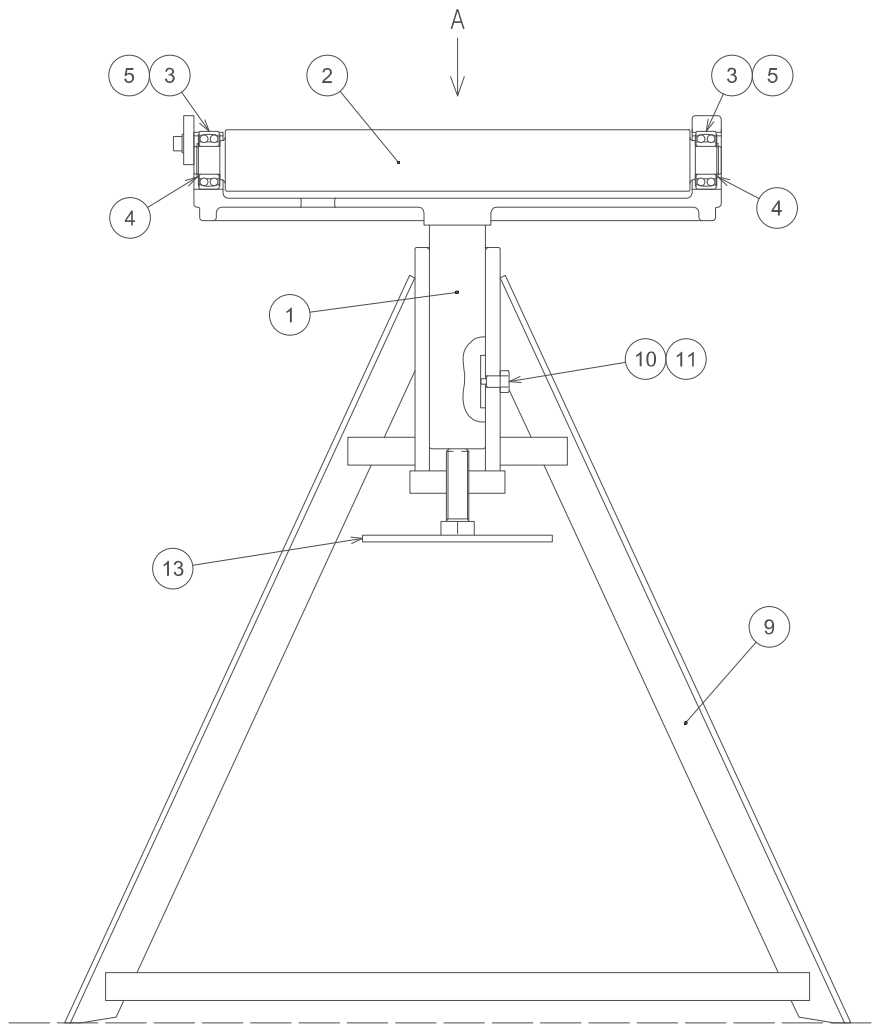

Unit No. 94
Roller Stand

Index	Code	Parts Name	Drawing No.	Type	Maker	Q'ty	Note
1	10419581	Roller Support	0602641 A			1	
2	10419582	Roller	0603129 C			1	
3	10380846	Ball Bearing	P400070511	2205	NSK & others	2	
4	10380847	Locating Snap Ring	P406100024	for shaftC-25	JIS	2	
5	10419583	Seal Plate	0603130 C			4	
6	10419584	Stopper	0602642 A			1	
7	10321923	Washer	P336000006	8(Normal)	JIS	2	
8	10380845	Wing Bolt	P338020006	Type-1M8X20	JIS	1	
9	10419585	Roller Stand	1200682 A			1	
10	10340917	Socket Set Screw	P330570034	M10X25(Dog-end)	JIS	1	
11	10427991	Nut	P332000006	M10	JIS	1	
12	10322202	Hex Socket Cap Screw	P330230006	M8X20		1	
13	10583738	Handle Bolt	0602645 A			1	

Unit No. 95
Roller Table-1/2

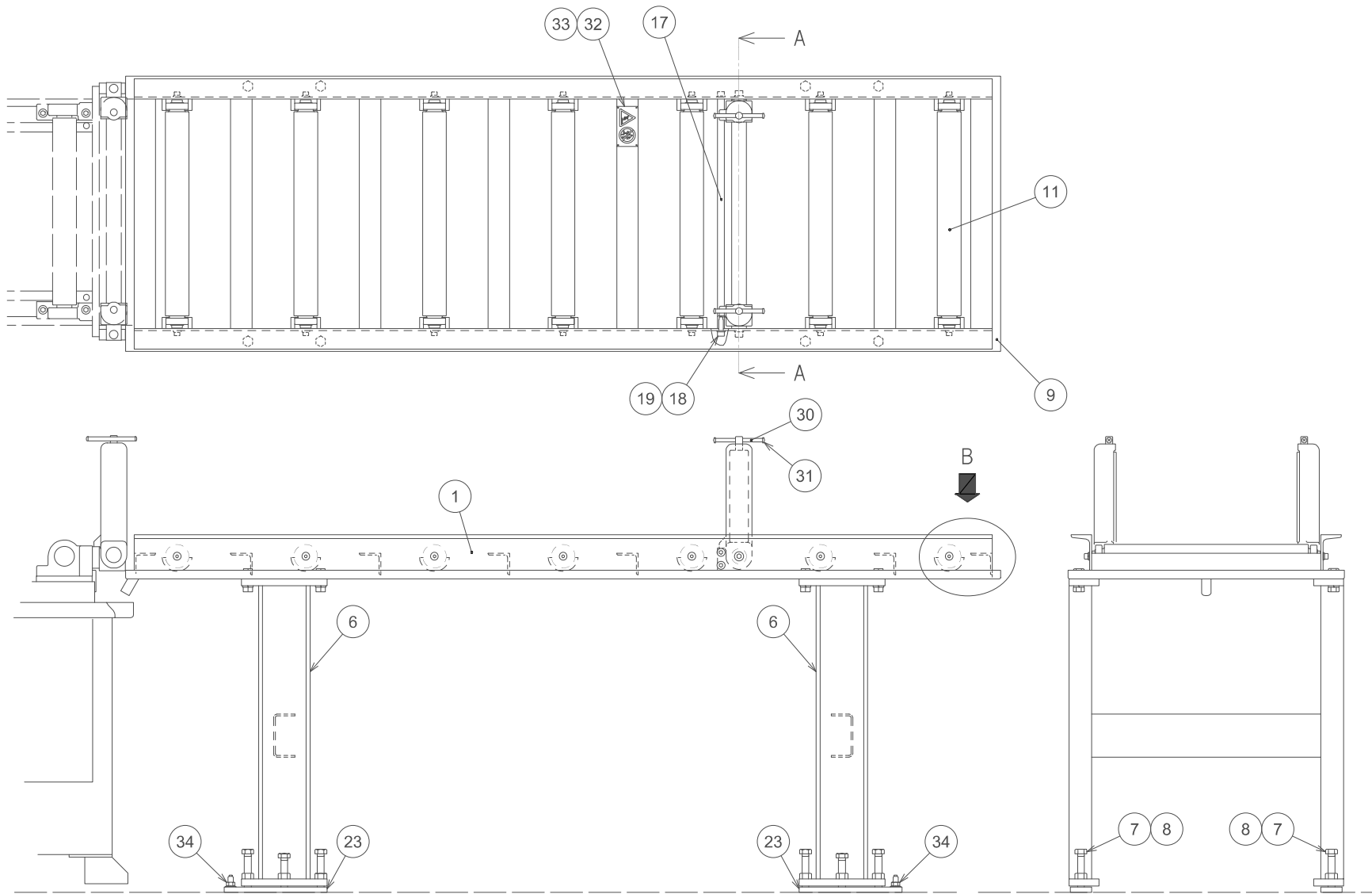

1278892--A

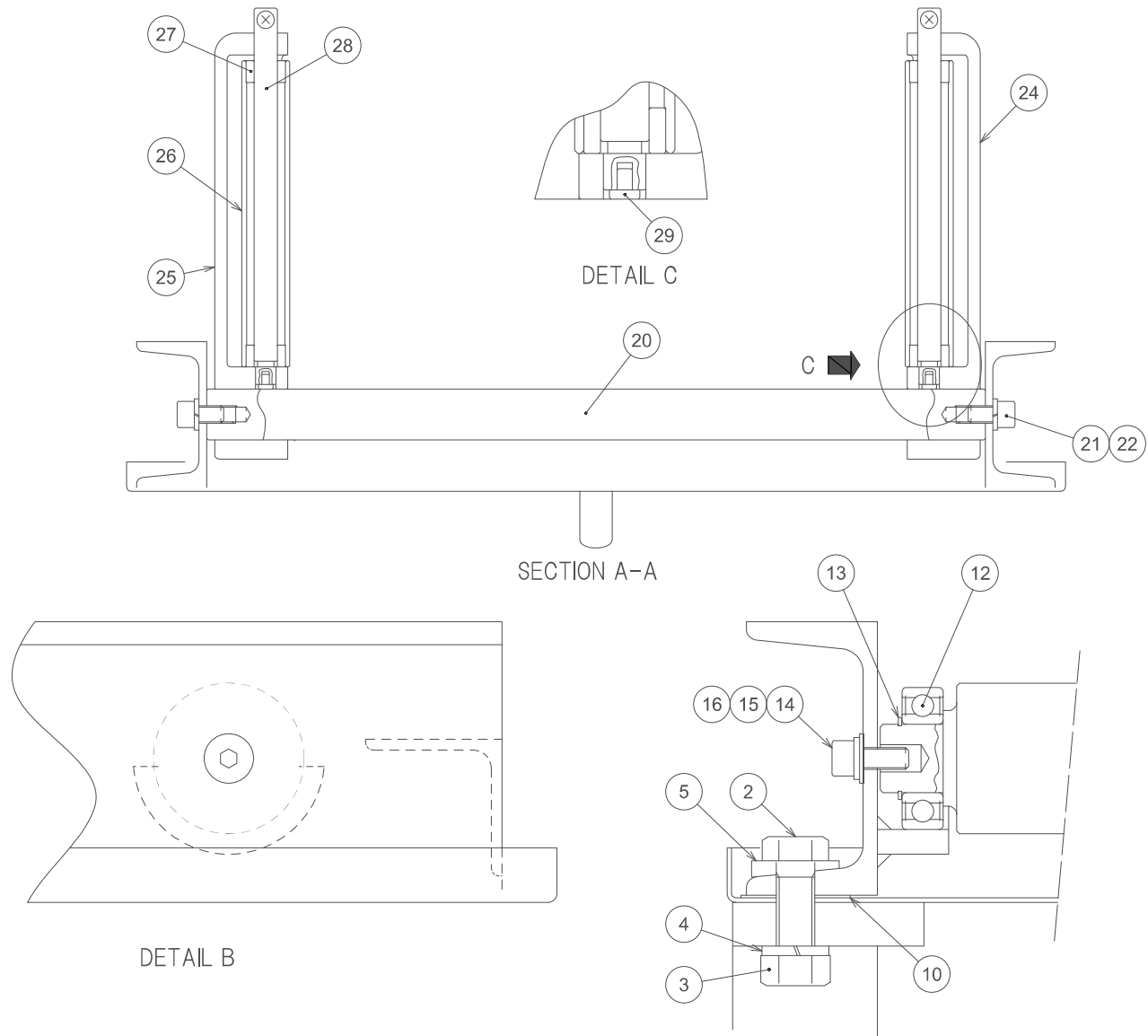

Unit No. 95
Roller Table

Index	Code	Parts Name	Drawing No.	Type	Maker	Q'ty	Note
1	10301492	Roller Support Base	RB02311--A			1	
2	10322260	Bolt	P330060004	M14X45	JIS	8	
3	10000826	Nut	P332000008	M14	JIS	8	
4	10000825	Spring Washer	P336050009	14	JIS	8	
5	10376120	Beveled Washer	P336210009	12-5 Deg.	Tokyo Byora	8	
6	10301496	Stand	RB02312--A			2	
7	10385469	Bolt	P330060031	M16X80(All-thread)	MOURI	12	
8	10421756	Nut	P332000009	M16	JIS	12	
9	10419588	Oil Pan	0637213 A			1	
10	10419589	Packing	1200654 A			4	
11	10419590	Roller	0637214 A			7	
12	10341319	Deep Groove Ball Bearing	P400017025	6205DDU	NSK	14	
13	10310821	Locating Snap Ring	P406108046	STW-25	OCHIAI	14	
14	10322202	Hex Socket Cap Screw	P330230006	M8X20		14	
15	10001521	Spring Washer	P336050006	8	JIS	14	
16	10321923	Washer	P336000006	8(Normal)	JIS	14	
17	10419591	Stopper Plate	0637215 A			1	
18	10341713	Hex Socket Cap Screw	P330240006	M10X20		4	
19	10001520	Spring Washer	P336050007	10	JIS	4	

Unit No. 95

Roller Table

Index	Code	Parts Name	Drawing No.	Type	Maker	Q'ty	Note
20	10419592	Guide Bar	0637216 A			1	
21	10329416	Hex Socket Cap Screw	P330250003	M12X20		2	
22	10000829	Spring Washer	P336050008	12	JIS	2	
23	10570050	Anchor Plate	1233671			4	
24	10380765	Roller Bracket Left	1238583 A			1	
25	10380764	Roller Bracket Right	1238582 A			1	
26	10378563	Roller	1238585			2	
27	10301139	Shaft Support	0603310--A			4	
28	10378562	Vertical Roller Set Bar	1238584			2	
29	10301140	Lock Piece	0603312--A			2	
30	10301141	Handle	0603314--C			2	
31	10323219	Pan Head Screw	P334100038	M5X8	JIS	4	
32	10301136	Warning Plate	RB0376651-			1	
32	10301137	Warning Plate	RB0376652-			1	
32	10300085	Warning Plate	1109434			1	
33	10375027	Drive Screw	P339100002	NO.2X4.8	Tokyo Byora	4	
34	10589309	Anchor	P338213005	C-1290	SANKO Technology	4	

Unit No. 96
Float Switch

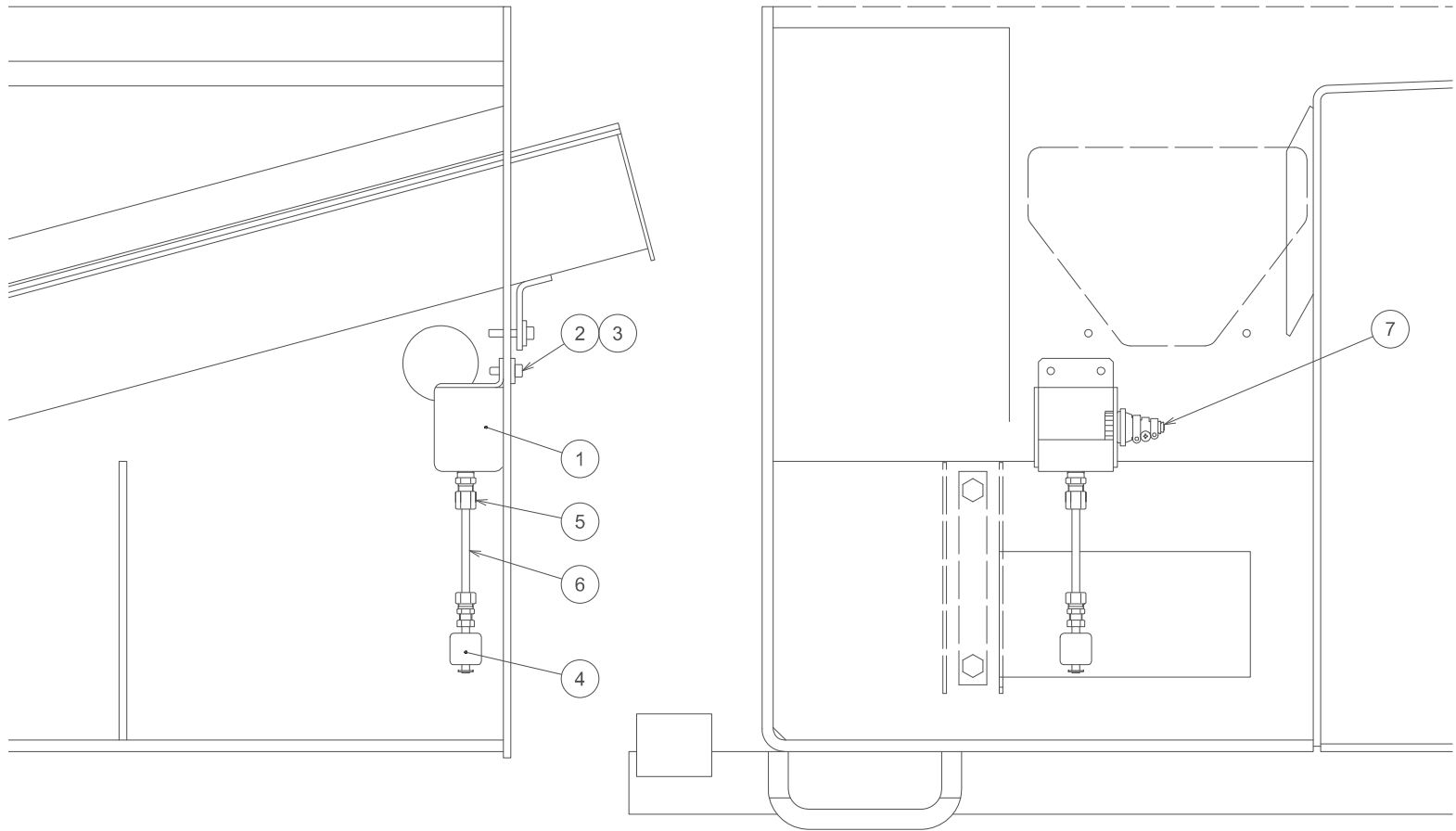

1230328
(1278796--A)

Unit No. 96
 Float Switch

Index	Code	Parts Name	Drawing No.	Type	Maker	Q'ty	Note
1	10301163	Float Switch Bracket	1230979			1	
2	10312832	Hex Socket Cap Screw	P330220009	M6X20	JIS	2	
3	10376462	Washer	1233546 A			2	
4	10580526	Level Switch	P829308004	OLV-2B(2M)	NOHKEN Industry	1	
5	10580527	Bite Type Pipe Fitting	P585033016	S-6X1/4	BAN SS	1	
6	10301164	Pipe for Float Switch	1230980			1	
7	10330110	Accessory for Conduit	P866103001	OA-1	OHM Electric	1	

Unit No. 97
Emergency Stop Button

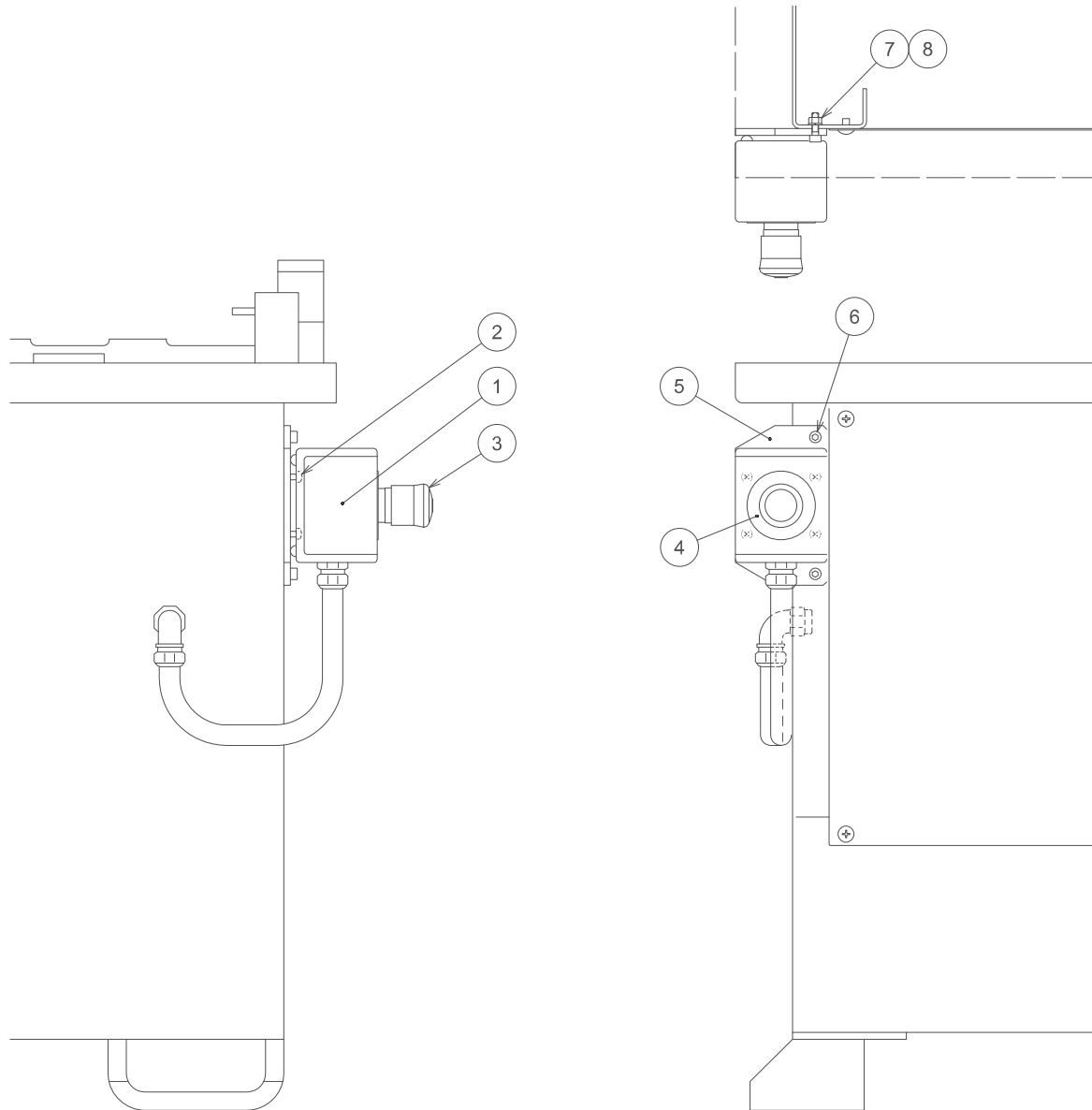

Unit No. 97

Emergency Stop Button

Index	Code	Parts Name	Drawing No.	Type	Maker	Q'ty	Note
1	10300202	Accessory for Switch	P821806017	KGNW111Y	IDEC	1	
2	10322224	Pan Head Screw	P334100039	M5X10	JIS	4	
3	10300201	Push Button Switch	P821088012	M22-PV/K01	MURA Electric	1	
4	10300203	Accessory for Switch	P821807007	M22-XBK	MURA Electric	1	
5	10301548	Base Plate	RB02648---			1	
6	10312832	Hex Socket Cap Screw	P330220009	M6X20	JIS	2	
7	10310351	Spring Washer	P336050005	6	JIS	2	
8	10589225	Nut	P332000004	M6	JIS	2	

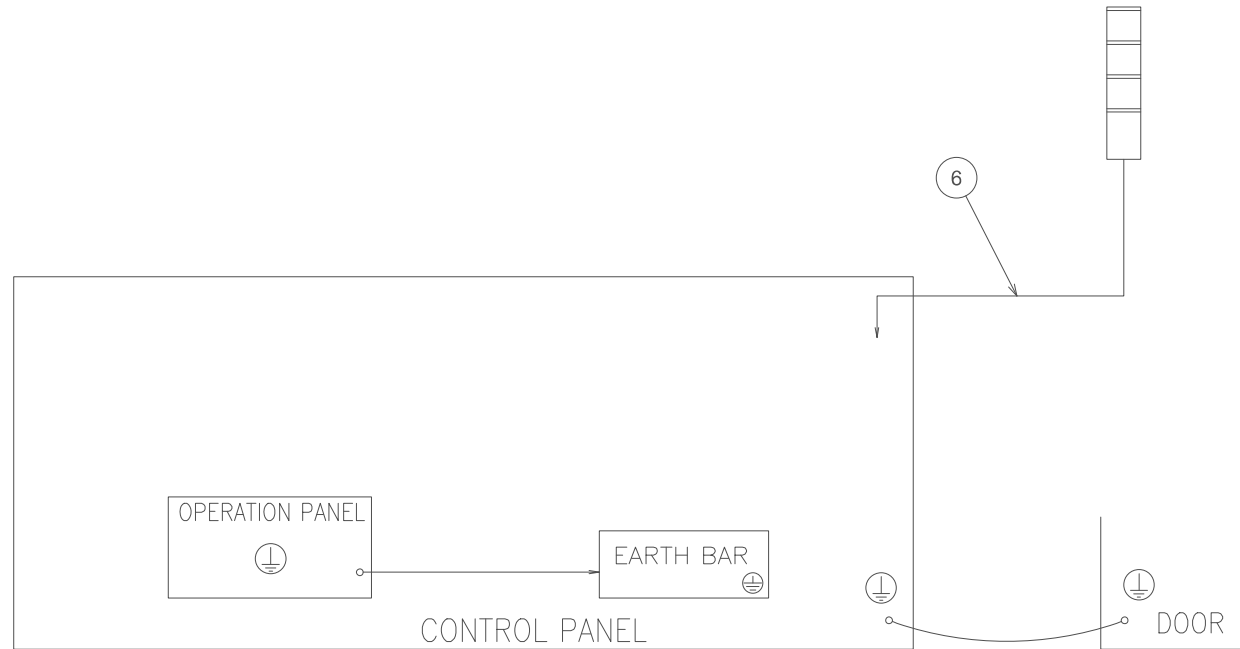

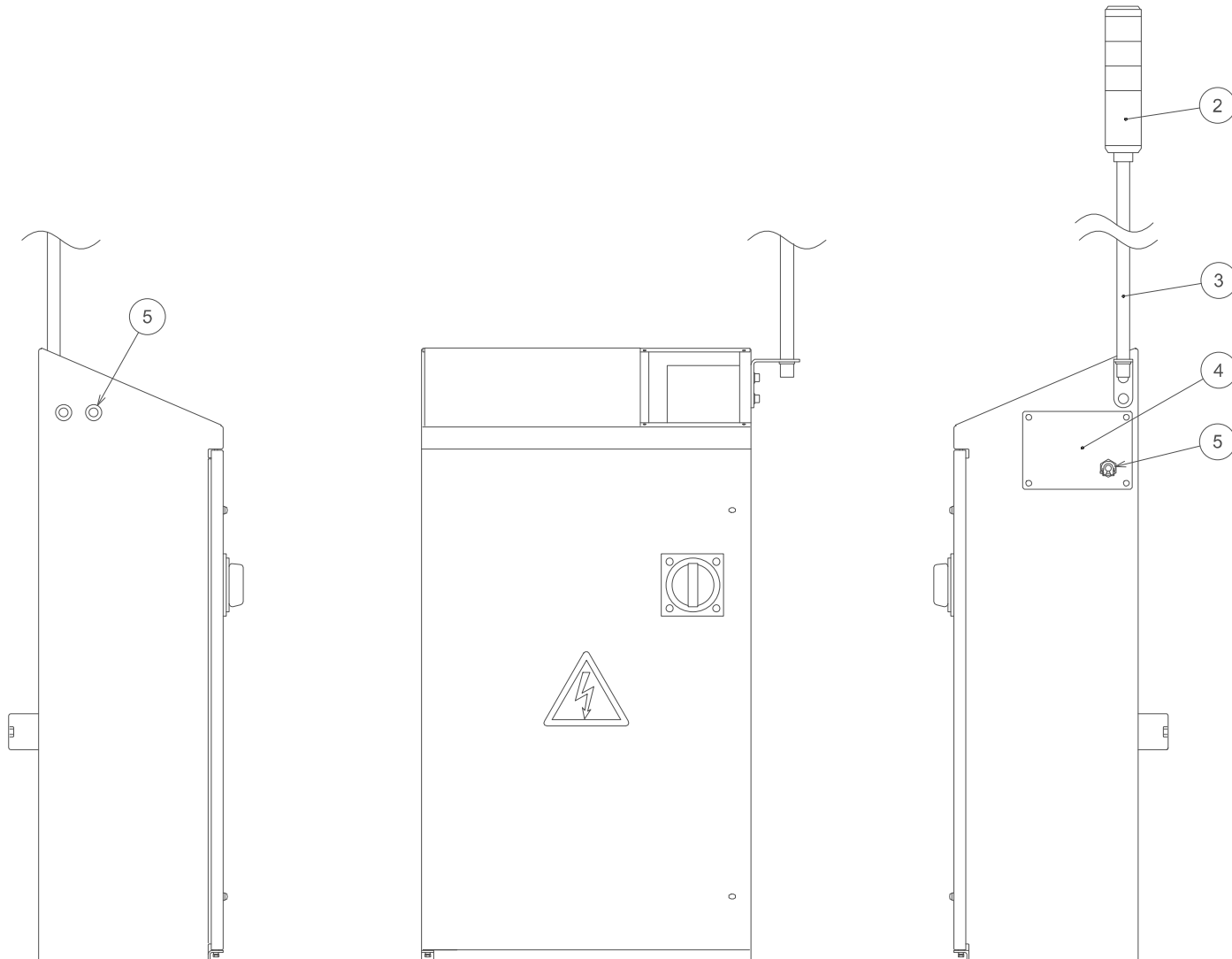

Unit No. 98
Signal Tower-3/3

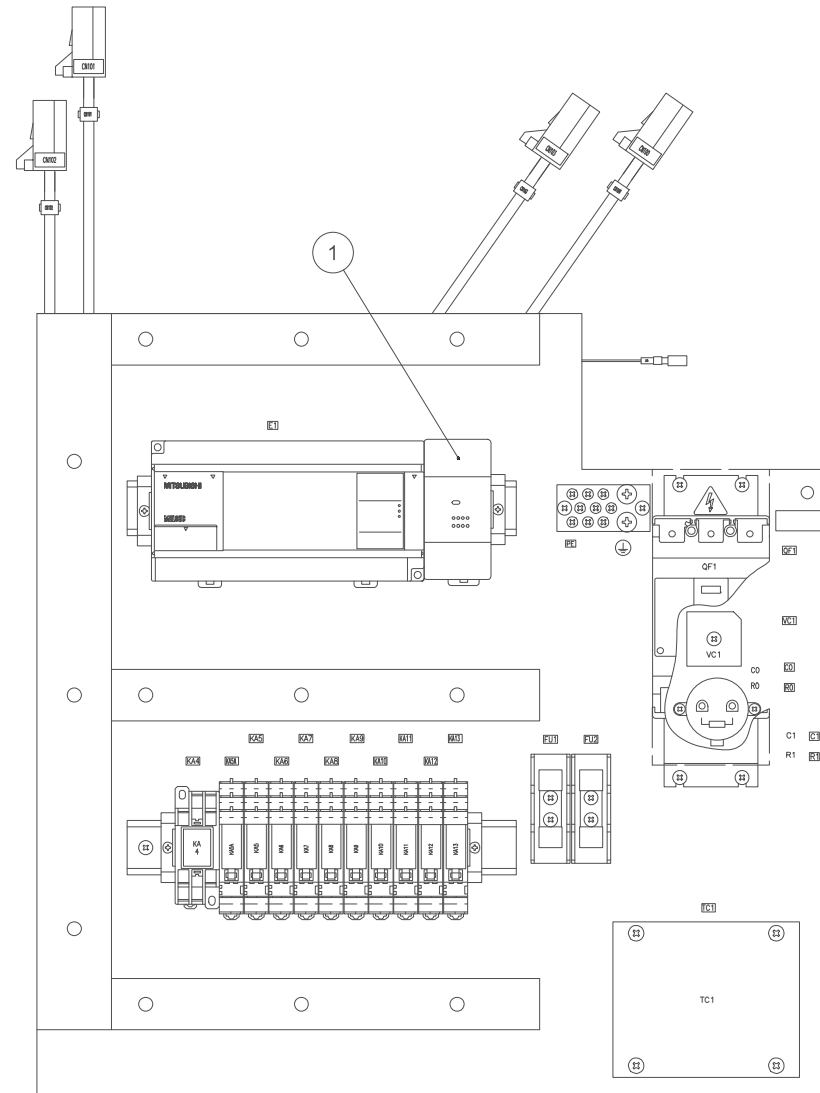
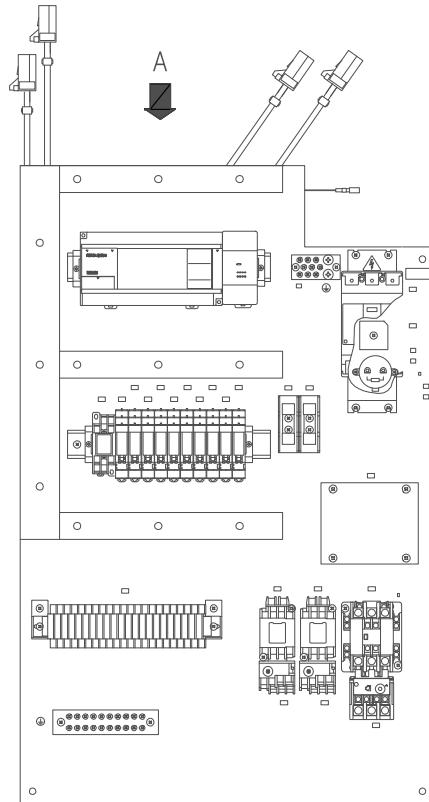

DETAIL A

RB02333---
(RB01576--B)

Unit No. 98
Signal Tower

Index	Code	Parts Name	Drawing No.	Type	Maker	Q'ty	Note
1	10583723	Accessory (Program Controller)	P767486037	FX2N-8EYR-ES/UL	MITSUBISHI	1	
2	10579311	Signal Tower	P642142046	LME-302W-RYG	PATLITE	1	
3	10579313	Accessory for Signal Light Unit	P642178006	SZ-70L(640MM)	PATLITE	1	
4	10300823	Cover Add Works	RB0077501B			1	
5	10330110	Accessory for Conduit	P866103001	OA-1	OHM Electric	2	
6	10301109	Signal Light Cable Add Works	RB0155131-			1	

Unit No. 99
Cover Open LS(1)

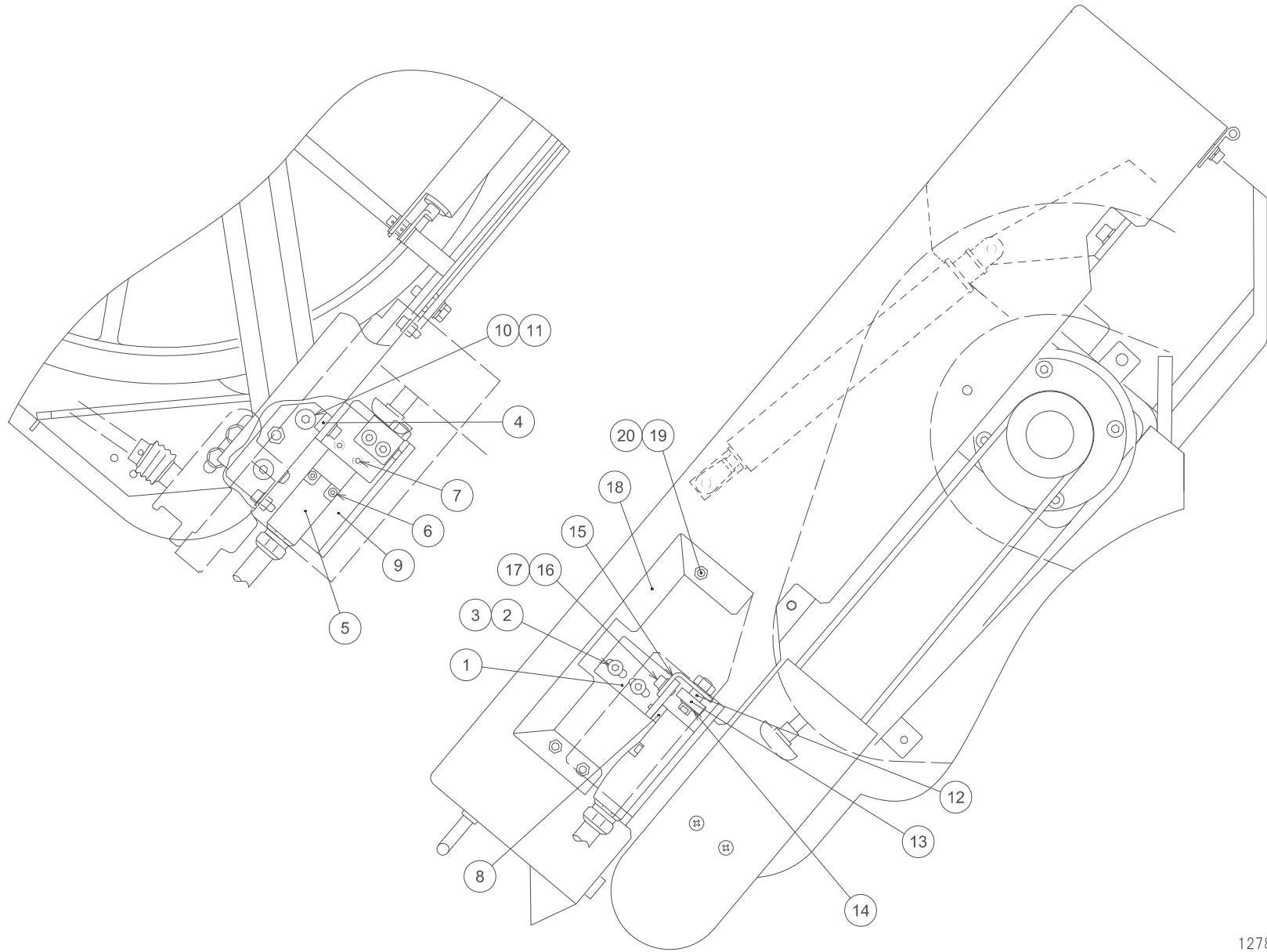

1278828--A

Unit No. 99
Cover Open LS(1)

Index	Code	Parts Name	Drawing No.	Type	Maker	Q'ty	Note
1	10301502	Bracket	RB02338---			1	
2	10312831	Hex Socket Cap Screw	P330220006	M6X15		2	
3	10321922	Washer	P336000005	6(Normal)	JIS	2	
4	10583711	Square Nut	1230689 A			1	
5	10300206	Limit Switch	P828008008	LS-11-ZB	MURA Electric	1	
6	10359526	Hex Socket Cap Screw	P330200023	M4X30		2	
7	10300139	Flat Head Screw	P334110009	M4X12	JIS	2	
8	10330110	Accessory for Conduit	P866103001	OA-1	OHM Electric	1	
9	10583713	LS Bracket	1230861 A			1	
10	10342325	Hex Socket Cap Screw	P330230004	M8X15		2	
11	10321923	Washer	P336000006	8(Normal)	JIS	2	
12	10583714	Shaft	1230863 A			1	
13	10301290	Deep Groove Ball Bearing	P400010725	6000ZZ	NSK(equality)	1	
14	10205431	Locating Snap Ring	P406108033	STW-10	OCHIAI	1	
15	10583715	Bracket	1230859			1	
16	10323201	Hex Socket Cap Screw	P330220004	M6X12	JIS	2	
17	10321922	Washer	P336000005	6(Normal)	JIS	2	
18	10583716	Cover	1230860 B			1	
19	10312831	Hex Socket Cap Screw	P330220006	M6X15		3	

Unit No. 99
Cover Open LS(1)

Index	Code	Parts Name	Drawing No.	Type	Maker	Q'ty	Note
20	10321922	Washer	P336000005	6(Normal)	JIS	3	

Unit No. 100
Cover Open LS(2) <EU Specification Machine>

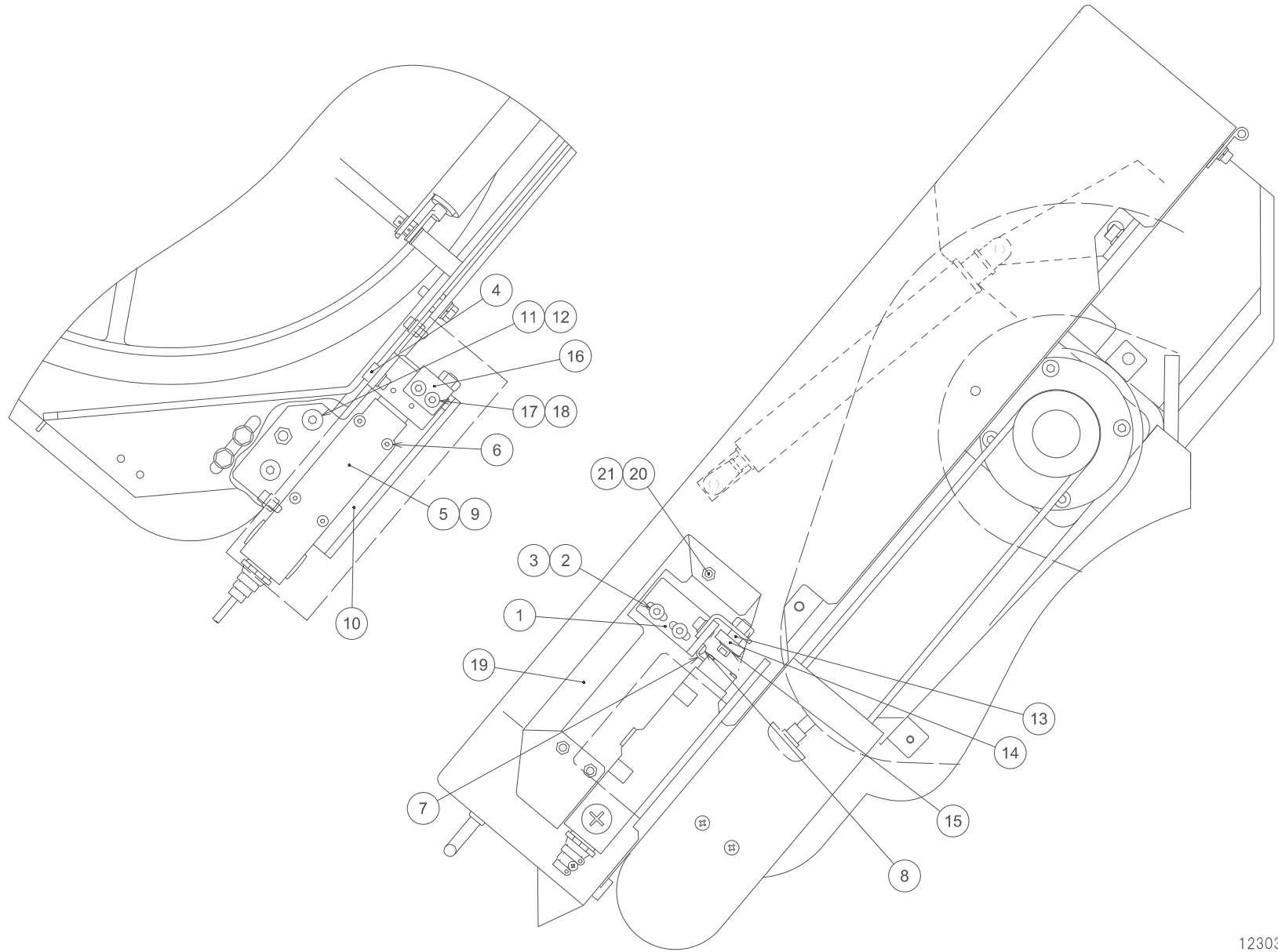

1230327

Unit No. 100
Cover Open LS(2)

Index	Code	Parts Name	Drawing No.	Type	Maker	Q'ty	Note
1	10583710	Bracket	1230858			1	
2	10312831	Hex Socket Cap Screw	P330220006	M6X15		2	
3	10321922	Washer	P336000005	6(Normal)	JIS	2	
4	10583711	Square Nut	1230689 A			1	
5	10301312	Door Switch	P829602030	D4GL-2AFA-A	OMRON	1	
6	10418224	Hex Socket Cap Screw	P330200021	M4X20		2	
7	10589517	Key for Switch	P829602008	D4DS-K2 (Key for Switch)	OMRON	1	
8	10337027	Pan Head Screw	P334100018	M4X10	JIS	2	
9	10330110	Accessory for Conduit	P866103001	OA-1	OHM Electric	1	
10	10301167	LS Bracket	1230983			1	
11	10342325	Hex Socket Cap Screw	P330230004	M8X15		2	
12	10321923	Washer	P336000006	8(Normal)	JIS	2	
13	10583714	Shaft	1230863 A			1	
14	10301290	Deep Groove Ball Bearing	P400010725	6000ZZ	NSK(equality)	1	
15	10205431	Locating Snap Ring	P406108033	STW-10	OCHIAI	1	
16	10583715	Bracket	1230859			1	
17	10323201	Hex Socket Cap Screw	P330220004	M6X12	JIS	2	
18	10321922	Washer	P336000005	6(Normal)	JIS	2	
19	10301168	Cover	1230984			1	

Unit No. 100

Cover Open LS(2)

Index	Code	Parts Name	Drawing No.	Type	Maker	Q'ty	Note
20	10312831	Hex Socket Cap Screw	P330220006	M6X15		3	
21	10321922	Washer	P336000005	6(Normal)	JIS	3	

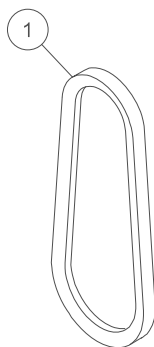

Unit No. 101

Option Accessory(1)

Index	Code	Parts Name	Drawing No.	Type	Maker	Q'ty	Note
1	10380583	V-belt	P223000016	M48		1	

Unit No. 102
Option Accessory(2) <Tool Set>

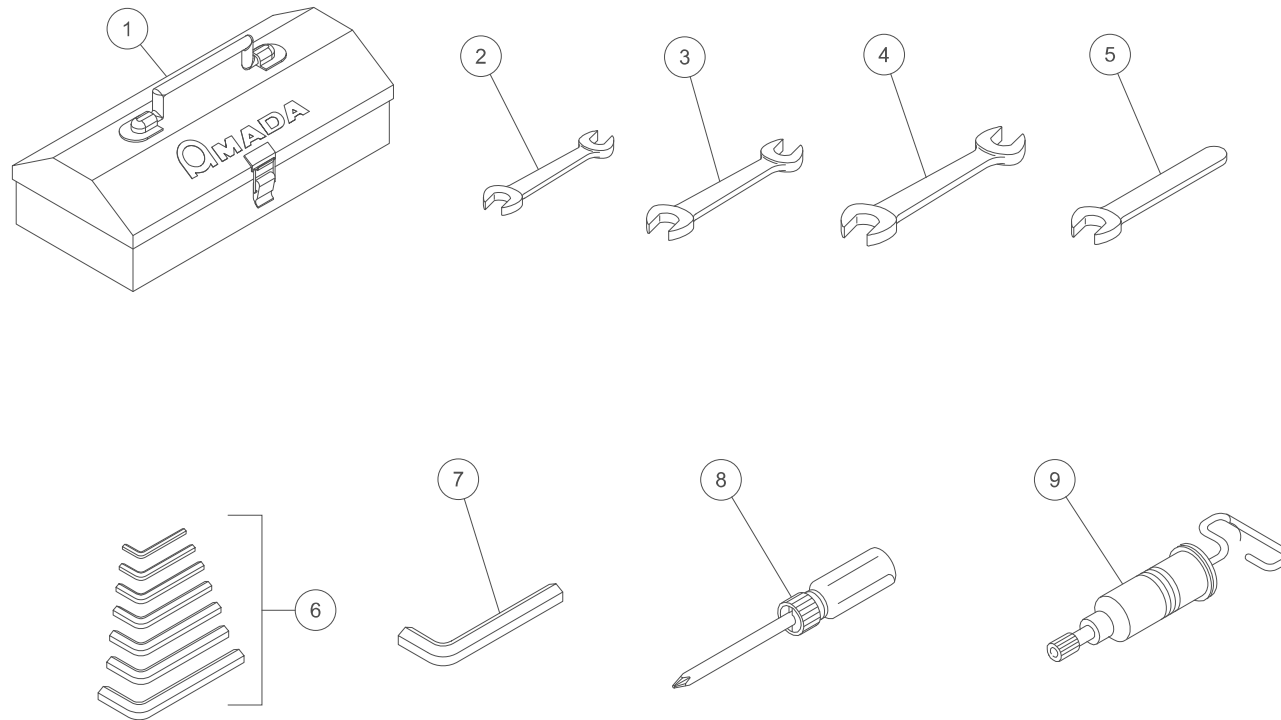

Unit No. 102

Option Accessory(2)

Index	Code	Parts Name	Drawing No.	Type	Maker	Q'ty	Note
1	10581225	Tool Box	7912021	350X150X65(TM-2)		1	
2	10345208	Wrench	P351010013	13X17		1	
3	10345209	Wrench	P351010010	19X22		1	
4	10345210	Wrench	P351010003	24X27		1	
5	10345211	Single Ended Wrench	P351000022	14		1	
6	10301287	Bar Wrench Set	P351040002	2.5-3-4-5-6-8-10		1	
7	10485309	Socket Screw Key	P351030011	14	JIS	1	
8	10485310	Screwdriver	P353000004	H2(Normal)	JIS	1	
9	10345225	Grease Gun	P359308003	KH-35	YAMADA	1	