

JUN. 2011

HFA SERIES

PARTS LIST

12782 HFA400_400W(407L)(EU_EXP_DOM)

From Serial No. DOM:47742001 / EXP STD:45742001 / EXP W:45752001 / EU STD:44742001 / EU W44752001 and after

Ver. 1.0

GENERAL INFORMATION

- * Specifications are subject to change without notice.
- * This parts list shows all of the parts used in your machine.
Please file this parts list for reference and refer to it when you order parts or maintain the machine.
- * This edition has been divided into sections.
Please refer to MACHINE COMPONENT.
- * The scale used on each page of drawings is different.
Please be aware that parts may seem to be different sizes on different pages.

INTRODUCTION

1. TABLE OF CONTENTS

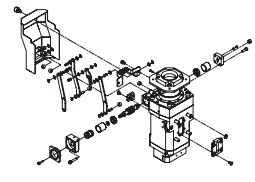
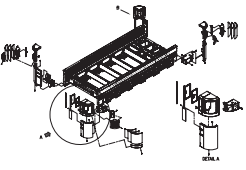
| 1 | 2 |
|--|---|
|  |  |

- a Unit No.
- b Unit Name
- c Assembly drawings shown in the main text.

2. MAIN TEXT

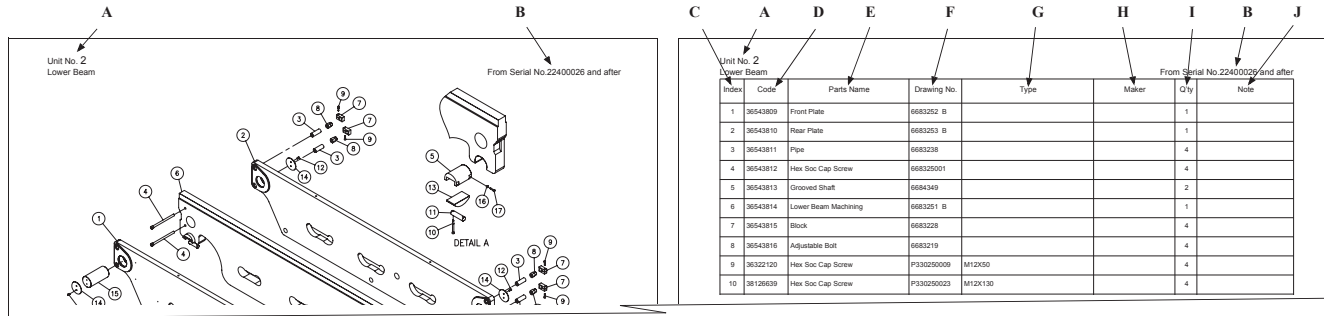

A Unit No. and Name

The Unit No. and Name are shown on relevant pages.

B Machine Serial No.

The Serial Nos. of machines corresponding to the information are shown.

C Index No.

The index No. for each part in a drawing is shown and corresponds to the list of parts for that drawing.

D Code

The individual Code No. for each part on the models is shown.

E Parts Name

The name (description) of each part.

F Drawing No.

The numbers of drawings relevant to the part are given.

G Type

The type description of each marketed item are shown.

H Maker

The manufacturer of each marketed item is shown.

I Quantity

The quantity of each part used on the models is shown.

J Notes

Cautions and notes necessary to the ordering each part.

ORDER INSTRUCTIONS

1. Confirm whether the model name and No. on the serial plate of the machine correspond to the numbers of the machines for which the parts list is effective.
2. Use the drawings in the Table of Contents to find the unit on which the part in question is shown in greater detail.
3. Spread out the referred pages.
4. Use the drawings and corresponding lists to confirm the specs, etc. of the part in question.
5. When ordering, please supply the following information:
 - (1)Machine Model
 - (2)Serial No.
 - (3)Code
 - (4)Quantity

UNIT LIST

| | |
|----------------------------------|-----------------------------|
| Name Plate | Roller Stand |
| Machine Body | Roller Table |
| Wedge-type Anchor Bolt | Option Accessory |
| Drive Wheel Speed Reducer | |
| Gearbox | ///// Factory Options ///// |
| Driven Wheel | Vise Pressure Control Valve |
| Saw Blade Guide | Blade Deviation Monitor |
| Hydraulic | Head-end Positioning |
| Swing Cylinder | Float Switch |
| Wire Brush | Signal Tower |
| Cutting Fluid | |
| Work Feeding Unit | |
| Feed Cylinder | |
| Vertical Roller | |
| Rear Vise | |
| Chip Conveyor | |
| Work Light | |
| Electric DOM | |
| Electric US | |
| Electric EU | |
| Electric AS | |
| Standard Accessory | |
| Saw Blade Breakage Detection LS | |
| Cover Open LS | |
| Emergency Stop Button | |
| ///// Optional Accessories ///// | |
| Multi-vise | |

© 2011 AMADA CO., LTD.

All rights reserved. Printed in Japan.

MACHINE COMPONENT (1)

Unit No.64 Electric DOM
 Unit No.68 Electric US
 Unit No.73 Electric EU
 Unit No.77 Electric AS
 Unit No.82-85 Standard Accessory
 Unit No.95 Blade Deviation Monitor
 Unit No.96 Roller Stand
 Unit No.104 Head-end Positioning
 Unit No.109,110 Option Accessory

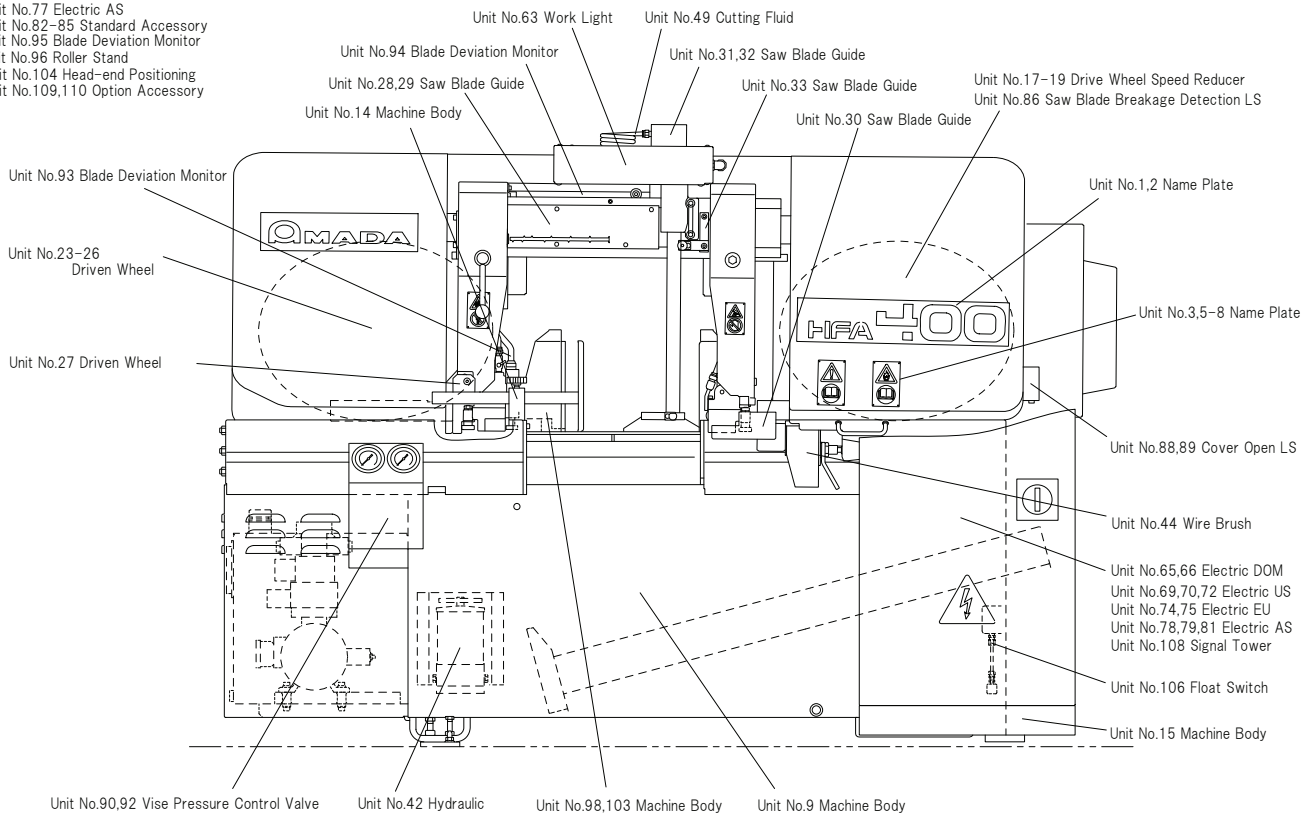

MACHINE COMPONENT (2)

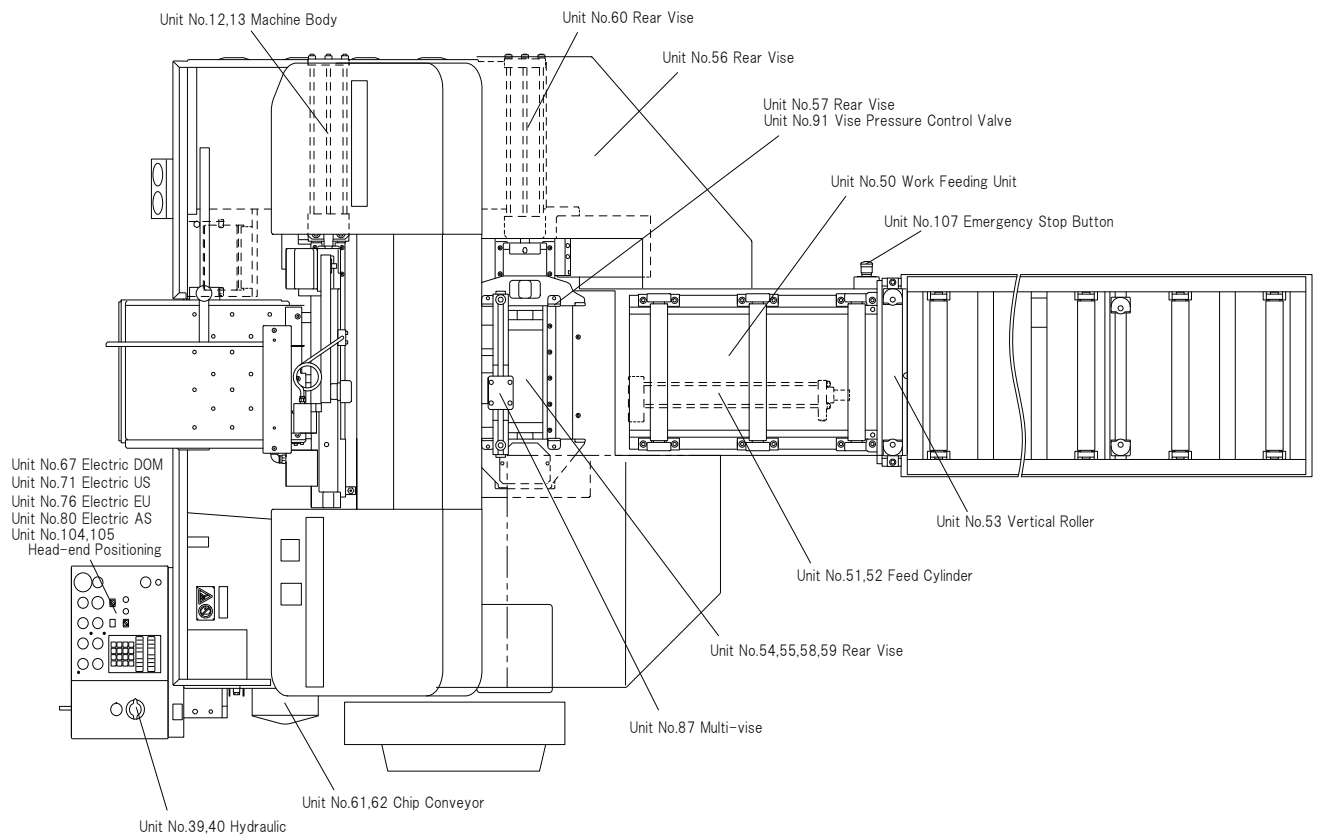

MACHINE COMPONENT (3)

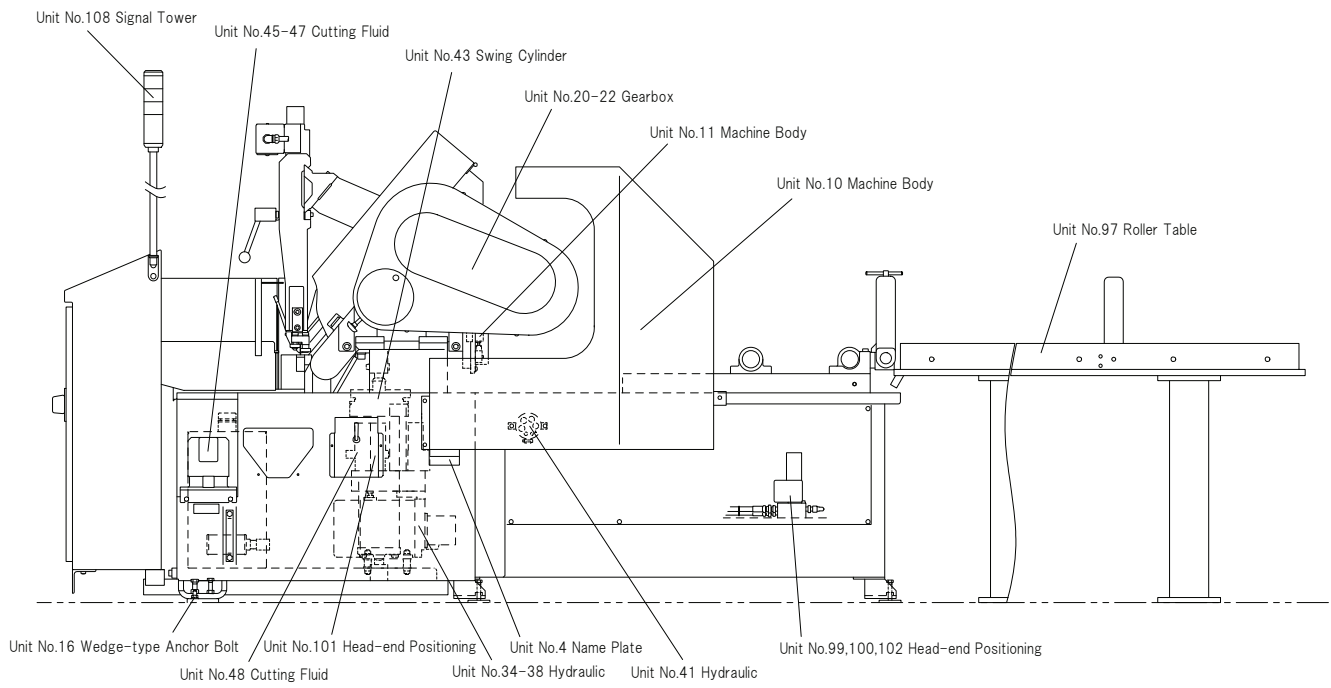

CONTENTS (1)

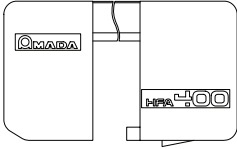
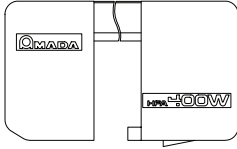
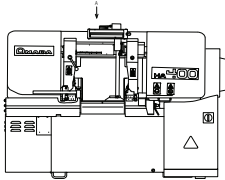
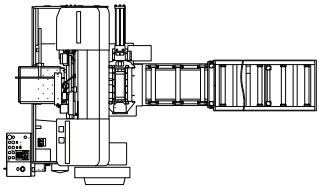
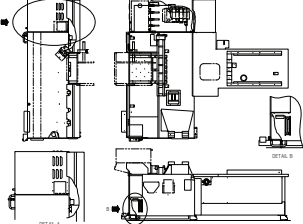
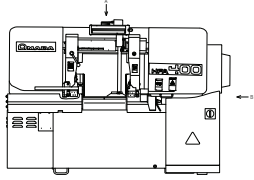
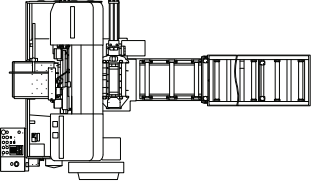
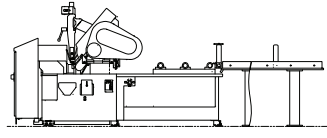
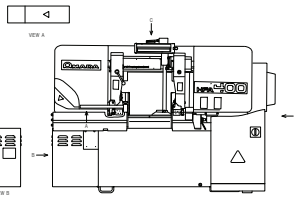
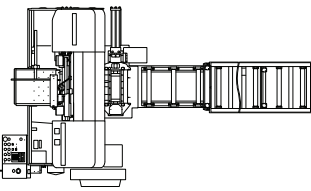
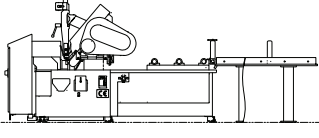
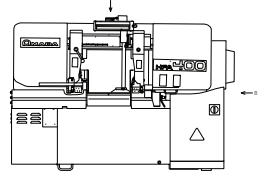
| | | | |
|--|--|---|--|
| <p>1 Name Plate(1)</p>  | <p>2 Name Plate(2)</p>  | <p>3 Name Plate(3)-1/2</p>  | <p>3 Name Plate(3)-2/2</p>  |
| <p>4 Name Plate(4)</p>  | <p>5 Name Plate(5)-1/3</p>  | <p>5 Name Plate(5)-2/3</p>  | <p>5 Name Plate(5)-3/3</p>  |
| <p>6 Name Plate(6)-1/3</p>  | <p>6 Name Plate(6)-2/3</p>  | <p>6 Name Plate(6)-3/3</p>  | <p>7 Name Plate(7)-1/3</p>  |

CONTENTS (2)

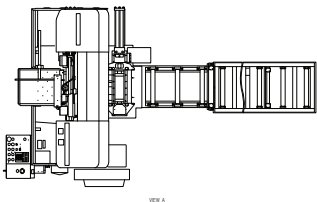
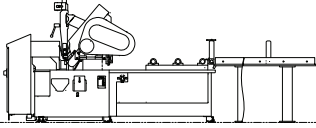
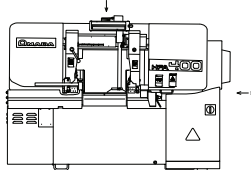
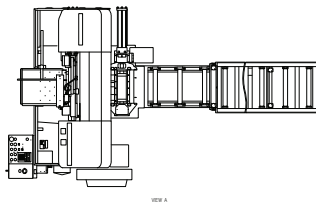
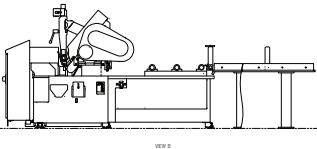
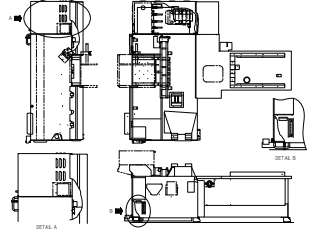
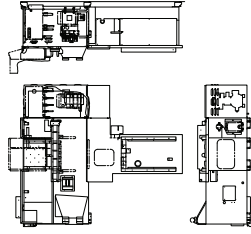
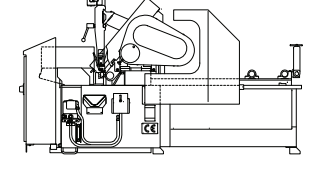
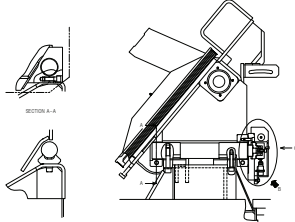
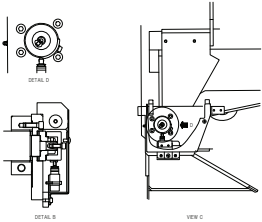
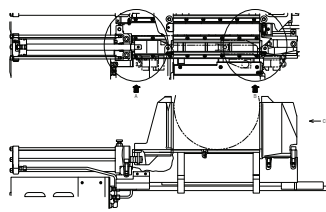
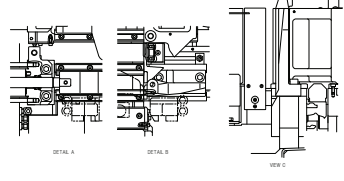
| | | | |
|--|--|--|---|
| <p>7 Name Plate(7)-2/3</p>  <p>VIEW A</p> | <p>7 Name Plate(7)-3/3</p>  <p>VIEW B</p> | <p>8 Name Plate(8)-1/3</p>  <p>VIEW C</p> | <p>8 Name Plate(8)-2/3</p>  <p>VIEW D</p> |
| <p>8 Name Plate(8)-3/3</p>  <p>VIEW E</p> | <p>9 Machine Body(1)-1/2</p>  <p>DETAIL A</p> | <p>9 Machine Body(1)-2/2</p>  <p>DETAIL B</p> | <p>10 Machine Body(2)</p>  <p>DETAIL C</p> |
| <p>11 Machine Body(3)-1/2</p>  <p>SECTION A-A</p> | <p>11 Machine Body(3)-2/2</p>  <p>DETAIL D VIEW D</p> | <p>12 Machine Body(4)-1/2</p>  <p>DETAIL E</p> | <p>12 Machine Body(4)-2/2</p>  <p>DETAIL A DETAIL B VIEW C</p> |

CONTENTS (3)

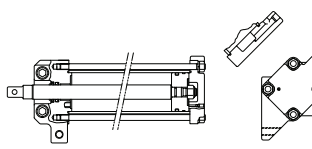
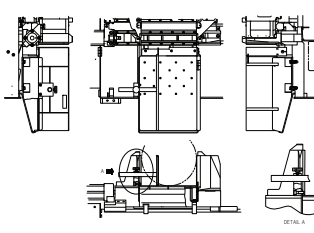
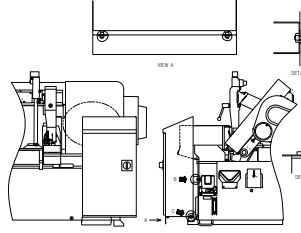
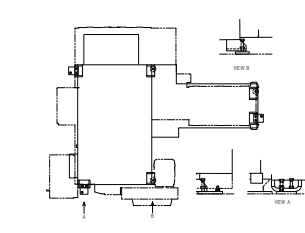
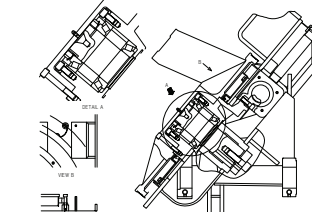
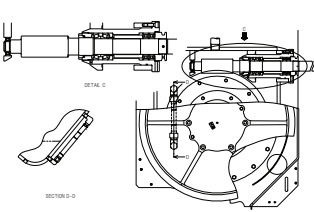
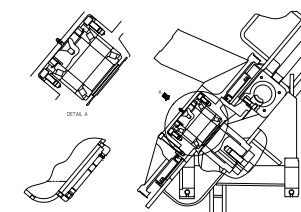
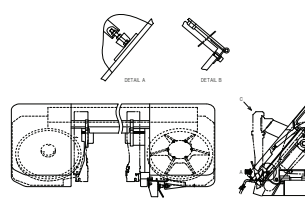
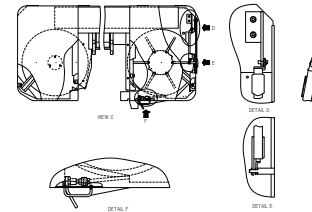
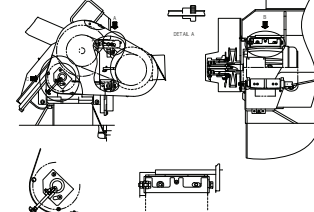
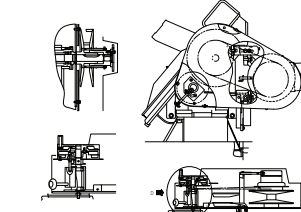
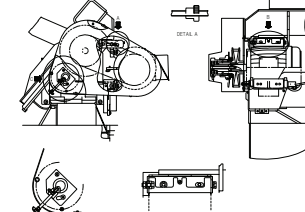
| | | | |
|--|---|--|---|
| <p>13 Machine Body(5)</p>  | <p>14 Machine Body(6)</p>  | <p>15 Machine Body(7)</p>  | <p>16 Wedge-type Anchor Bolt</p>  |
| <p>17 Drive Wheel Speed Reducer(1)-1/2</p>  | <p>17 Drive Wheel Speed Reducer(1)-2/2</p>  | <p>18 Drive Wheel Speed Reducer(2)</p>  | <p>19 Drive Wheel Speed Reducer(3)-1/2</p>  |
| <p>19 Drive Wheel Speed Reducer(3)-2/2</p>  | <p>20 Gearbox(1)-1/2</p>  | <p>20 Gearbox(1)-2/2</p>  | <p>21 Gearbox(2)</p>  |

CONTENTS (4)

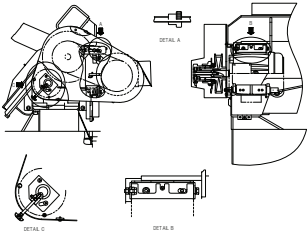
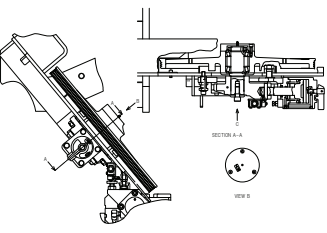
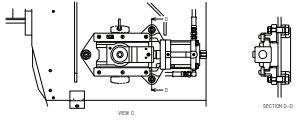
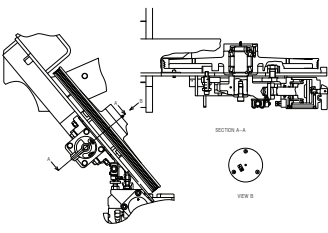
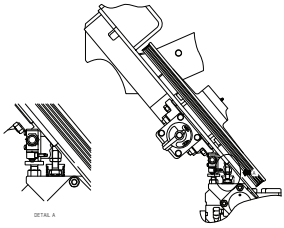
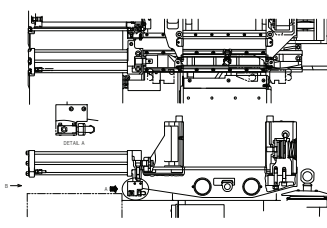
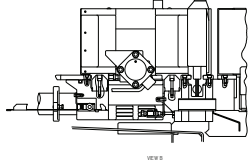
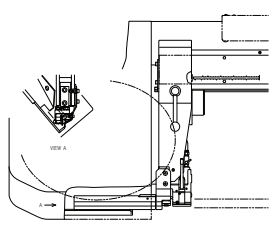
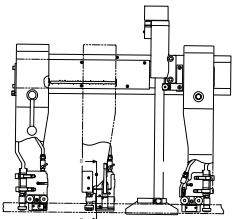
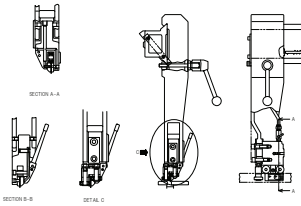
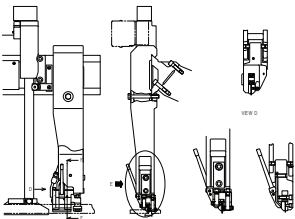
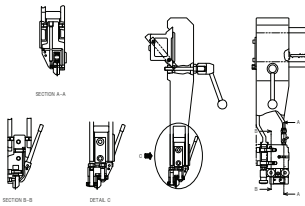
| | | | |
|--|--|---|--|
| <p>22 Gearbox(3)</p>  | <p>23 Driven Wheel(1)-1/2</p>  | <p>23 Driven Wheel(1)-2/2</p>  | <p>24 Driven Wheel(2)</p>  |
| <p>25 Driven Wheel(3)</p>  | <p>26 Driven Wheel(4)-1/2</p>  | <p>26 Driven Wheel(4)-2/2</p>  | <p>27 Driven Wheel(5)</p>  |
| <p>28 Saw Blade Guide(1)-1/3</p>  | <p>28 Saw Blade Guide(1)-2/3</p>  | <p>28 Saw Blade Guide(1)-3/3</p>  | <p>29 Saw Blade Guide(2)-1/2</p>  |

CONTENTS (5)

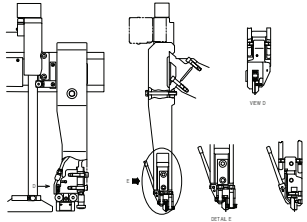
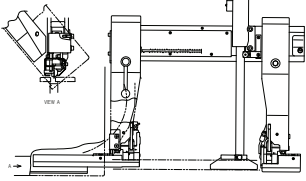
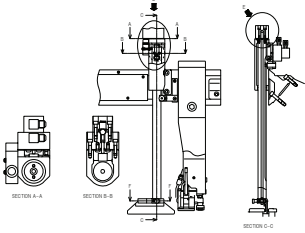
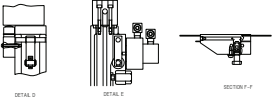
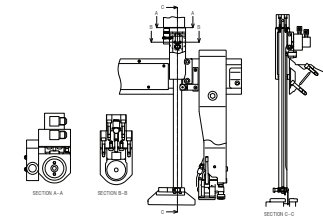
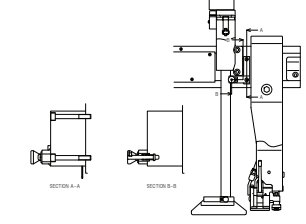
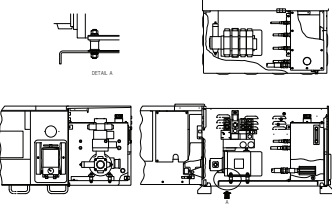
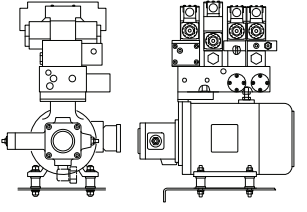
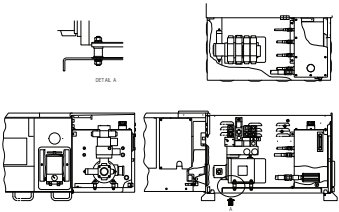
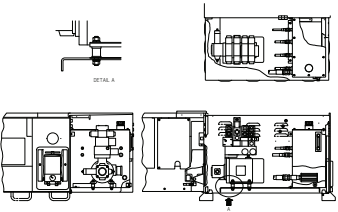
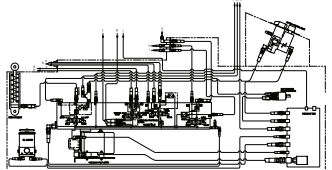
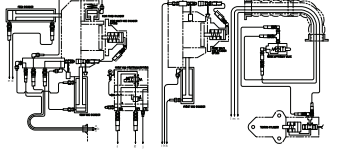
| | | | |
|--|---|---|--|
| <p>29 Saw Blade Guide(2)-2/2</p>  | <p>30 Saw Blade Guide(3)</p>  | <p>31 Saw Blade Guide(4)-1/2</p>  | <p>31 Saw Blade Guide(4)-2/2</p>  |
| <p>32 Saw Blade Guide(5)</p>  | <p>33 Saw Blade Guide(6)</p>  | <p>34 Hydraulic(1)</p>  | <p>35 Hydraulic(2)</p>  |
| <p>36 Hydraulic(3)</p>  | <p>37 Hydraulic(4)</p>  | <p>38 Hydraulic(5)-1/2</p>  | <p>38 Hydraulic(5)-2/2</p>  |

CONTENTS (6)

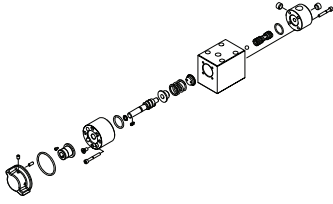
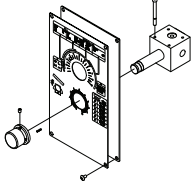
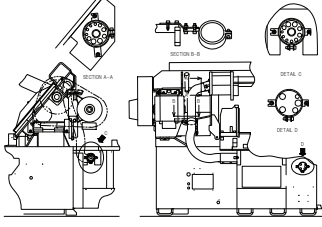
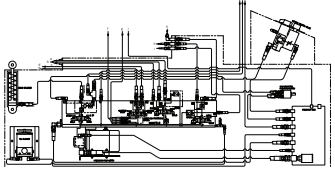
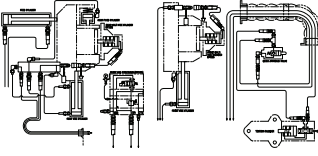
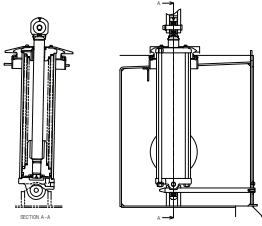
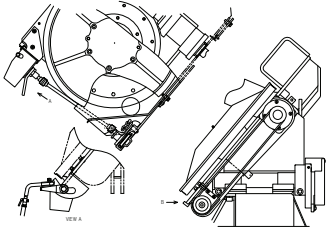
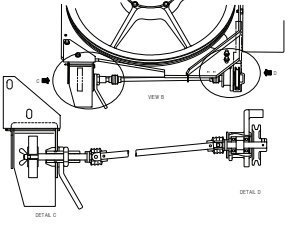
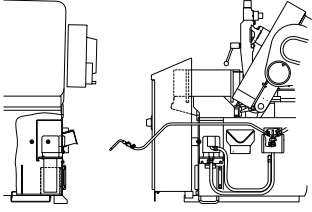
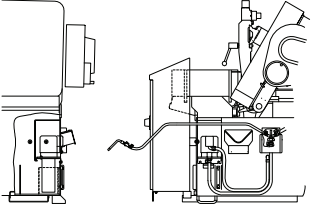
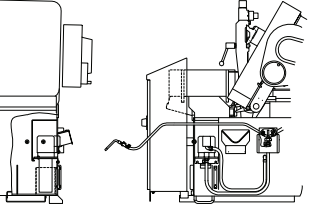
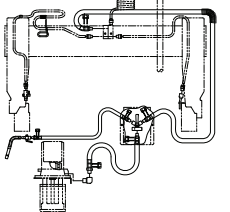
| | | | |
|---|---|--|---|
| 39 Hydraulic(6) | 40 Hydraulic(7) | 41 Hydraulic(8) | 42 Hydraulic(9)-1/2 |
|  |  |  |  |
| 42 Hydraulic(9)-2/2 | 43 Swing Cylinder | 44 Wire Brush-1/2 | 44 Wire Brush-2/2 |
|  |  |  |  |
| 45 Cutting Fluid(1) | 46 Cutting Fluid(2) | 47 Cutting Fluid(3) | 48 Cutting Fluid(4) |
|  |  |  |  |

CONTENTS (7)

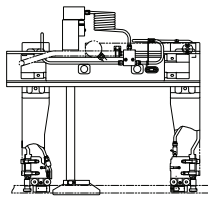
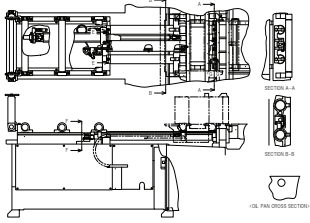
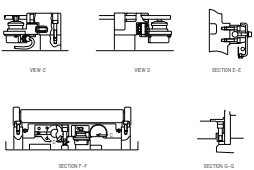
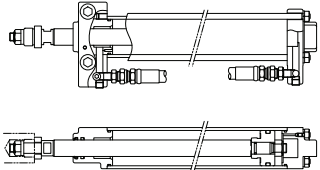
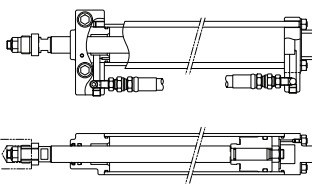
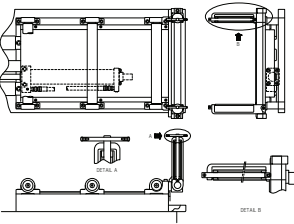
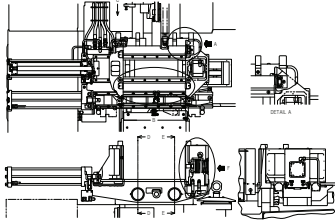
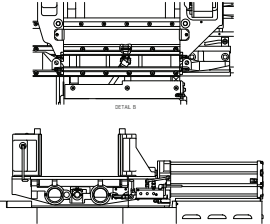
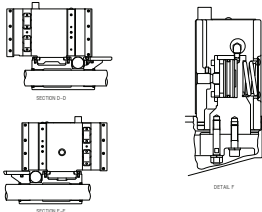
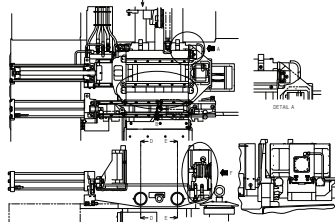
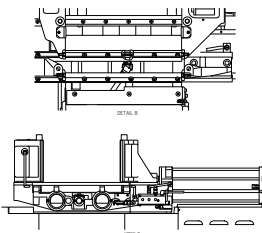
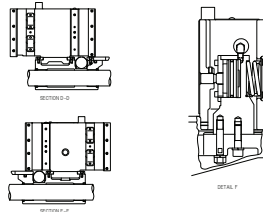
| | | | |
|--|---|--|--|
| <p>49 Cutting Fluid(5)</p>  | <p>50 Work Feeding Unit-1/2</p>  | <p>50 Work Feeding Unit-2/2</p>  | <p>51 Feed Cylinder(1)</p>  |
| <p>52 Feed Cylinder(2)</p>  | <p>53 Vertical Roller</p>  | <p>54 Rear Vise(1)-1/3</p>  | <p>54 Rear Vise(1)-2/3</p>  |
| <p>54 Rear Vise(1)-3/3</p>  | <p>55 Rear Vise(2)-1/3</p>  | <p>55 Rear Vise(2)-2/3</p>  | <p>55 Rear Vise(2)-3/3</p>  |

CONTENTS (8)

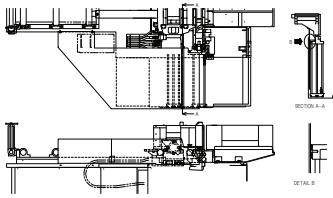
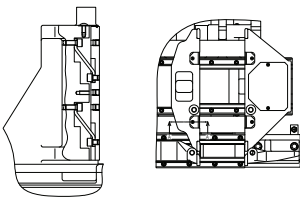
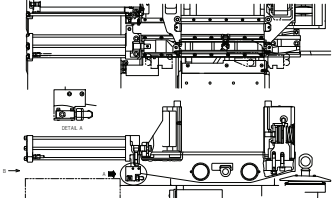
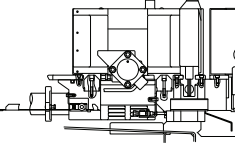
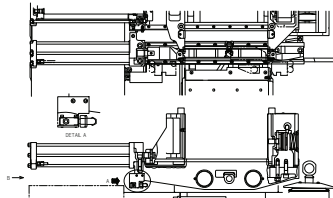
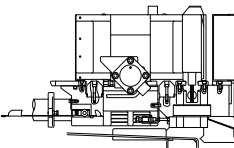
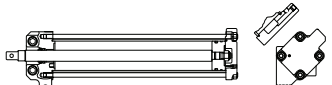
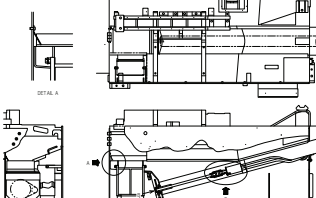
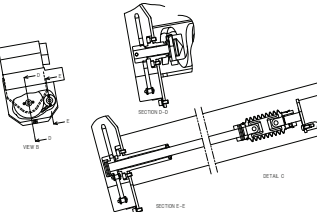
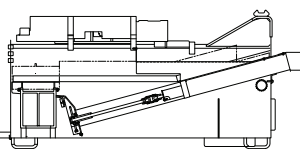
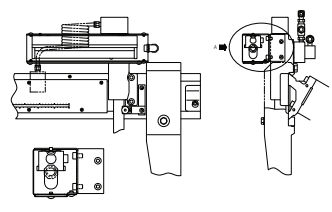
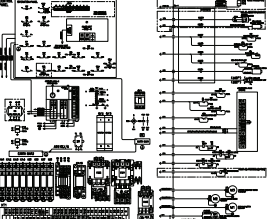
| | | | |
|--|--|---|---|
| <p>56 Rear Vise(3)</p>  | <p>57 Rear Vise(4)</p>  | <p>58 Rear Vise(5)-1/2</p>  | <p>58 Rear Vise(5)-2/2</p>  |
| <p>59 Rear Vise(6)-1/2</p>  | <p>59 Rear Vise(6)-2/2</p>  | <p>60 Rear Vise(7)</p>  | <p>61 Chip Conveyor(1)-1/2</p>  |
| <p>61 Chip Conveyor(1)-2/2</p>  | <p>62 Chip Conveyor(2)</p>  | <p>63 Work Light</p>  | <p>64 Electric DOM(1)</p>  |



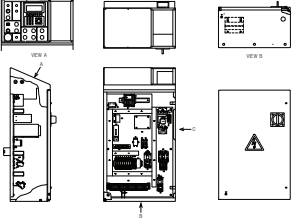
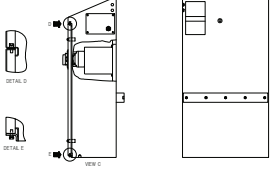
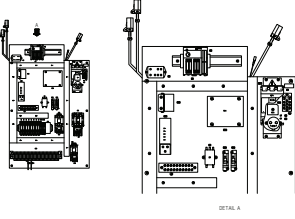
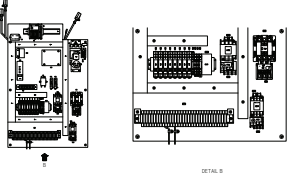
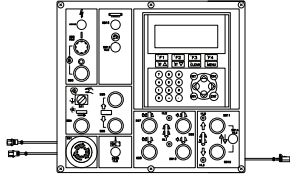
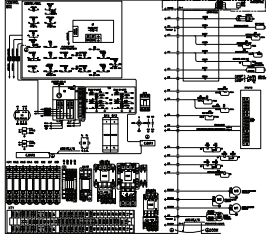
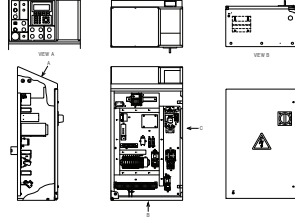
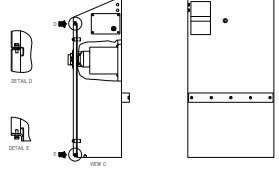
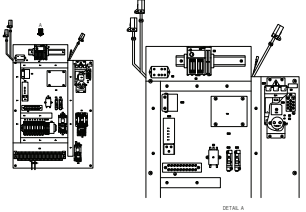
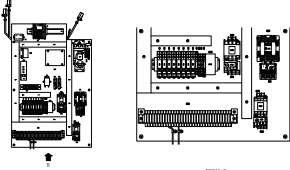
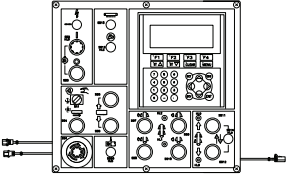
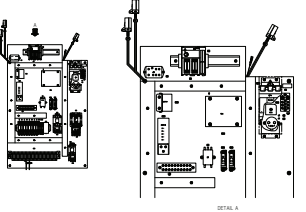

CONTENTS (9)

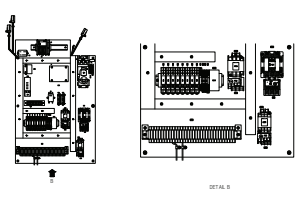
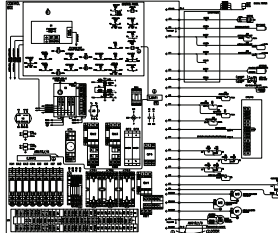
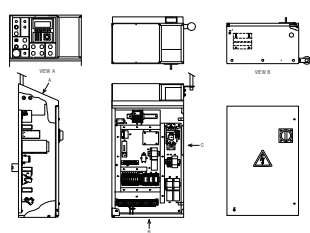
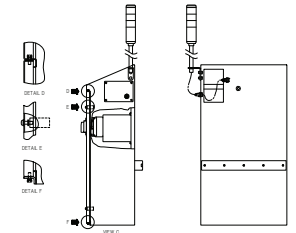
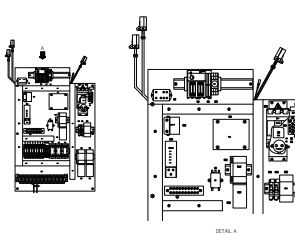
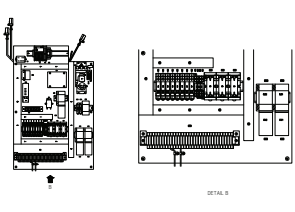
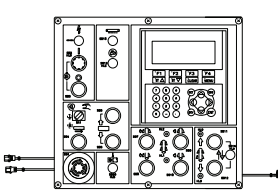
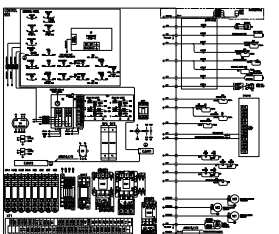
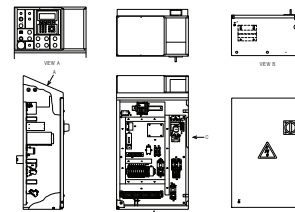
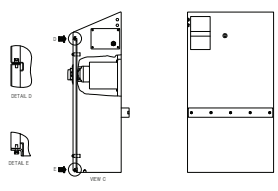
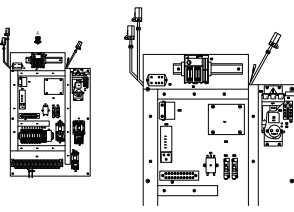
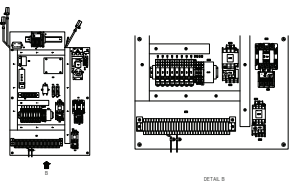
| | | | |
|--|--|--|--|
| <p>65 Electric DOM(2)-1/2</p>  | <p>65 Electric DOM(2)-2/2</p>  | <p>66 Electric DOM(3)-1/2</p>  | <p>66 Electric DOM(3)-2/2</p>  |
| <p>67 Electric DOM(4)</p>  | <p>68 Electric US(1)</p>  | <p>69 Electric US(2)-1/2</p>  | <p>69 Electric US(2)-2/2</p>  |
| <p>70 Electric US(3)-1/2</p>  | <p>70 Electric US(3)-2/2</p>  | <p>71 Electric US(4)</p>  | <p>72 Electric US(5)-1/2</p>  |

CONTENTS (10)

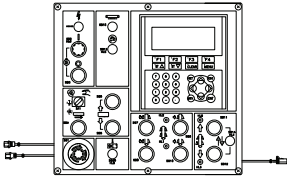
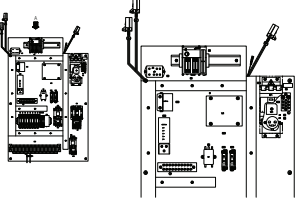
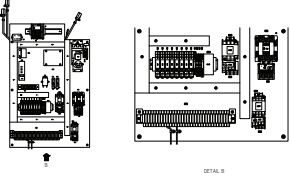
| | | | |
|--|--|---|--|
| <p>72 Electric US(5)-2/2</p>  | <p>73 Electric EU(1)</p>  | <p>74 Electric EU(2)-1/2</p>  | <p>74 Electric EU(2)-2/2</p>  |
| <p>75 Electric EU(3)-1/2</p>  | <p>75 Electric EU(3)-2/2</p>  | <p>76 Electric EU(4)</p>  | <p>77 Electric AS(1)</p>  |
| <p>78 Electric AS(2)-1/2</p>  | <p>78 Electric AS(2)-2/2</p>  | <p>79 Electric AS(3)-1/2</p>  | <p>79 Electric AS(3)-2/2</p>  |

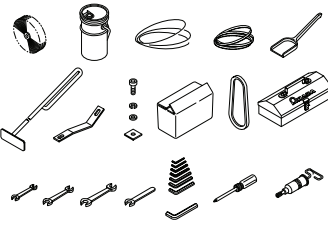
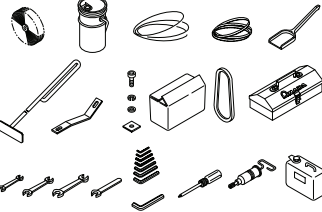
CONTENTS (11)

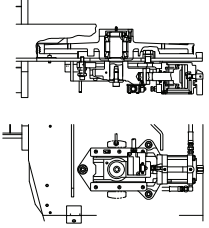
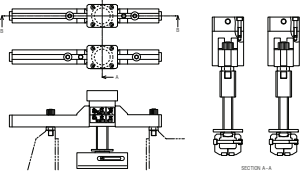
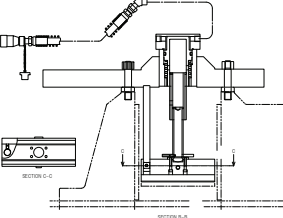
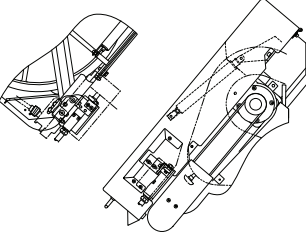
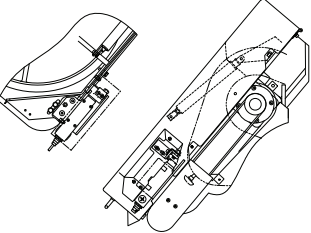
| | | | |
|--|--|--|--|
| <p>80 Electric AS(4)</p>  | <p>81 Electric AS(5)-1/2</p>  | <p>81 Electric AS(5)-2/2</p>  | <p>82 Standard Accessory(1)</p>  |
| <p>83 Standard Accessory(2)</p>  | <p>84 Standard Accessory(3)</p>  | <p>85 Standard Accessory(4)</p>  | <p>86 Saw Blade Breakage Detection LS</p>  |
| <p>87 Multi-vise-1/2</p>  | <p>87 Multi-vise-2/2</p>  | <p>88 Cover Open LS(1)</p>  | <p>89 Cover Open LS(2)</p>  |

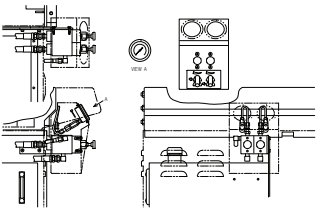
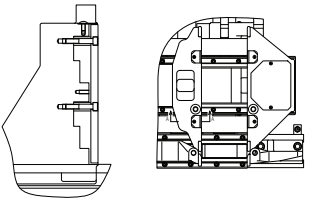
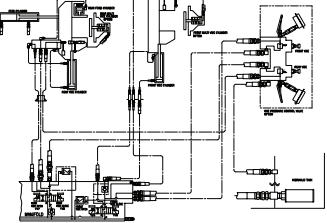
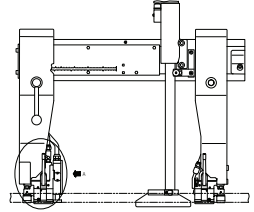
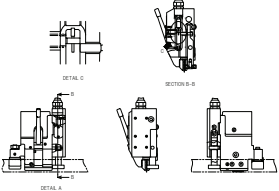
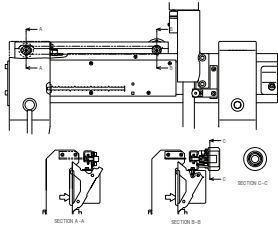
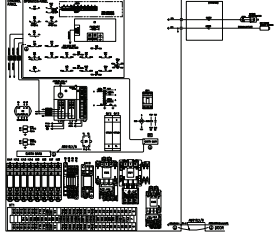
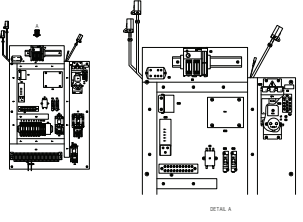
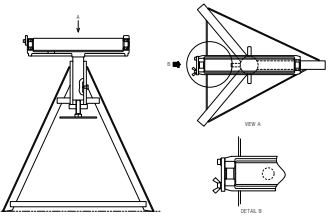
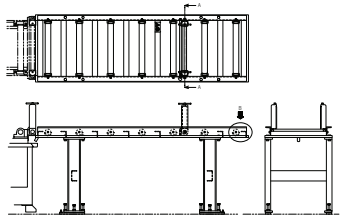
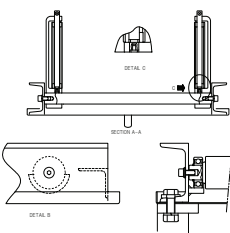
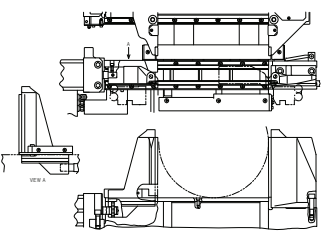

CONTENTS (12)

| | | | |
|---|--|--|---|
| <p>90 Vise Pressure Control Valve(1)</p>  | <p>91 Vise Pressure Control Valve(2)</p>  | <p>92 Vise Pressure Control Valve(3)</p>  | <p>93 Blade Deviation Monitor(1)-1/2</p>  |
| <p>93 Blade Deviation Monitor(1)-2/2</p>  | <p>94 Blade Deviation Monitor(2)</p>  | <p>95 Blade Deviation Monitor(3)-1/2</p>  | <p>95 Blade Deviation Monitor(3)-2/2</p>  |
| <p>96 Roller Stand</p>  | <p>97 Roller Table-1/2</p>  | <p>97 Roller Table-2/2</p>  | <p>98 Head-end Positioning(1)</p>  |

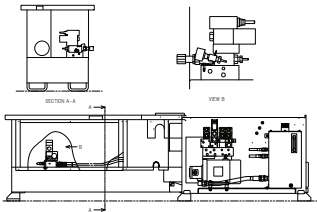
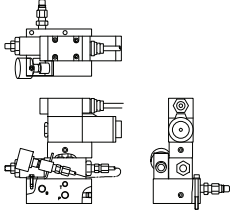
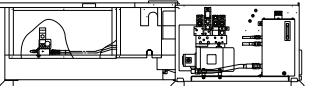
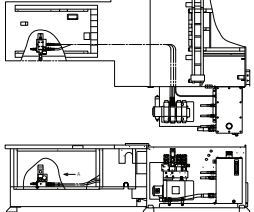
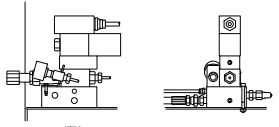
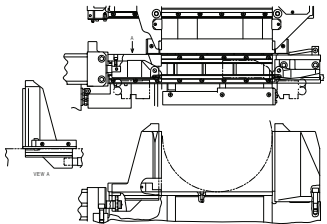
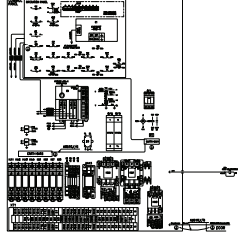
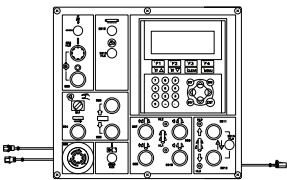
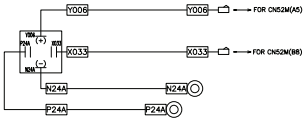
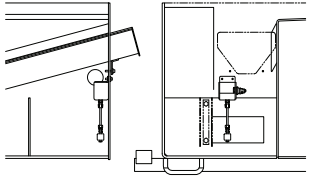
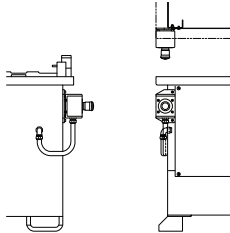
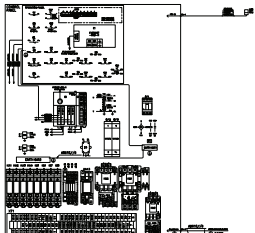
CONTENTS (13)

| | | | |
|--|---|--|---|
| <p>99 Head-end Positioning(2)</p>  | <p>100 Head-end Positioning(3)</p>  | <p>101 Head-end Positioning(4)</p>  | <p>102 Head-end Positioning(5)-1/2</p>  |
| <p>102 Head-end Positioning(5)-2/2</p>  | <p>103 Head-end Positioning(6)</p>  | <p>104 Head-end Positioning(7)-1/2</p>  | <p>104 Head-end Positioning(7)-2/2</p>  |
| <p>105 Head-end Positioning(8)</p>  | <p>106 Float Switch</p>  | <p>107 Emergency Stop Button</p>  | <p>108 Signal Tower-1/2</p>  |

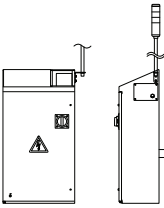
CONTENTS (14)

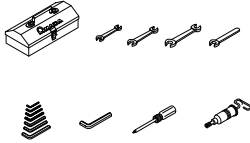
| 108 | Signal Tower-2/2 | 109 | Option Accessory(1) | 110 | Option Accessory(2) |
|-----|---|---|--|-----|---------------------|
| |  |  |  | | |
| | | | | | |
| | | | | | |
| | | | | | |
| | | | | | |

Unit No. 1
Name Plate(1) <Model Plate>

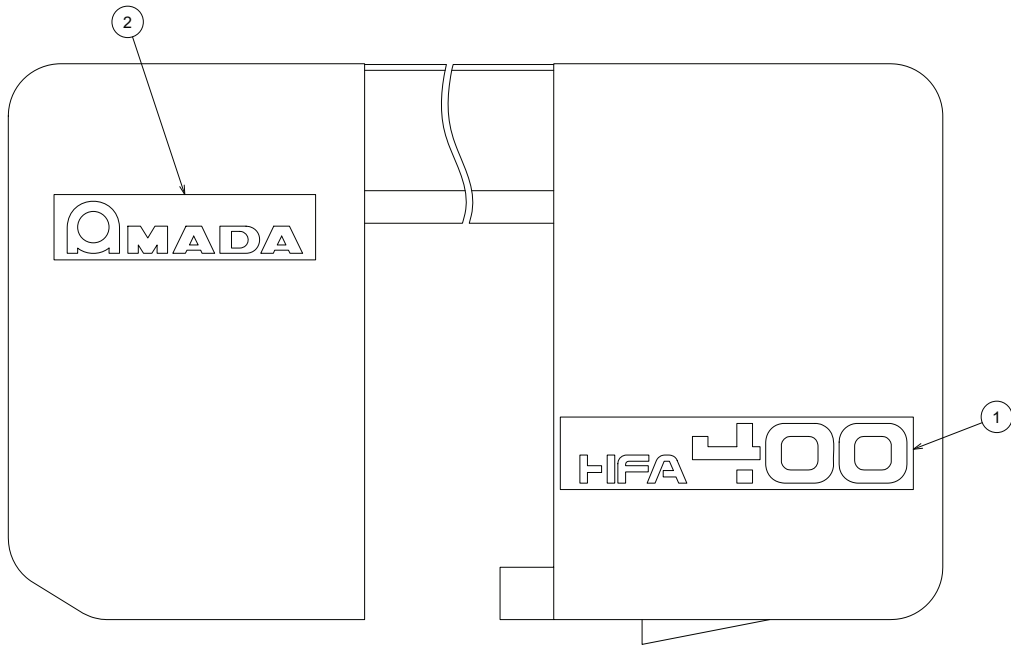

1278778--A
(1278811--A)

Unit No. 1
Name Plate(1)

| Index | Code | Parts Name | Drawing No. | Type | Maker | Q'ty | Note |
|-------|----------|-------------|-------------|------|-------|------|------|
| 1 | 10302004 | Model Plate | RB01811--A | | | 1 | |
| 2 | 10300442 | Amada Plate | RB00368--- | | | 1 | |

Unit No. 2
Name Plate(2) <HFA400W>

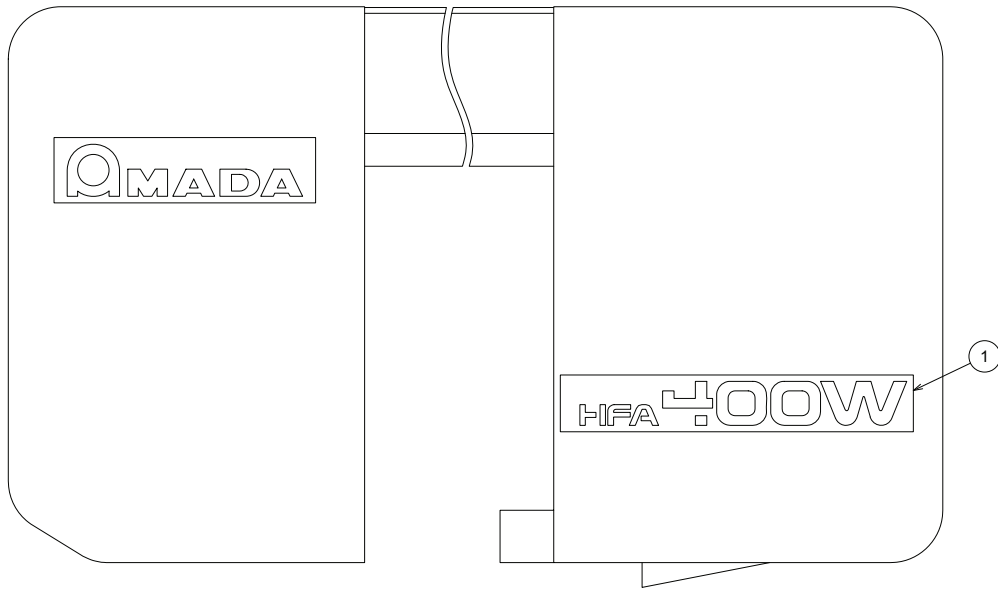

RB02371---
(RB02471---)

Unit No. 2

Name Plate(2)

| Index | Code | Parts Name | Drawing No. | Type | Maker | Q'ty | Note |
|-------|----------|-------------|-------------|------|-------|------|------|
| 1 | 10302024 | Model Plate | RB02372--- | | | 1 | |

Unit No. 3
Name Plate(3)-1/2 <DOM>

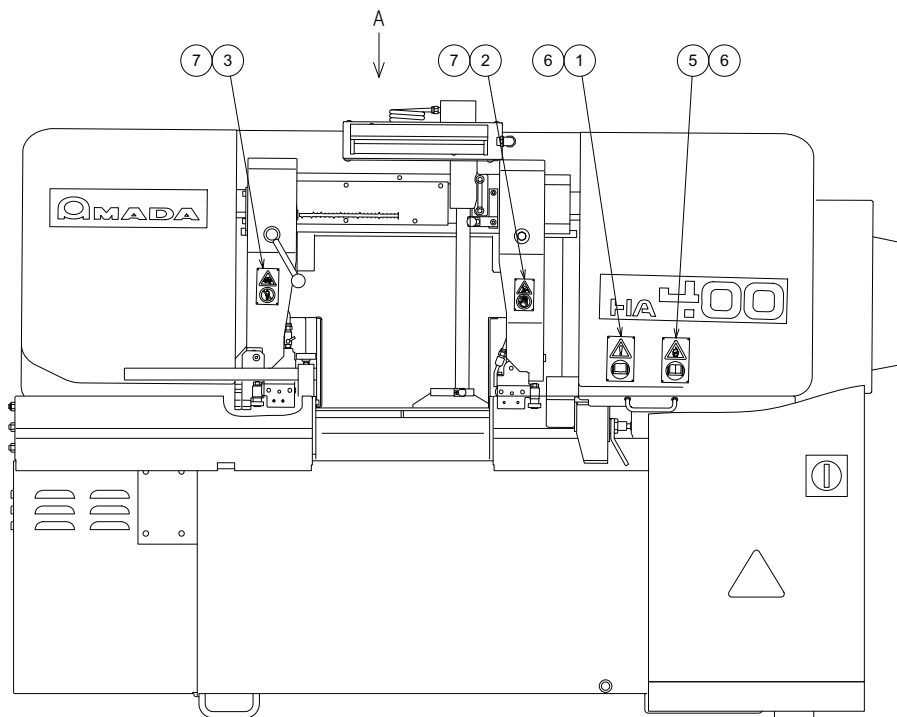

1278811--A

Unit No. 3
Name Plate(3)-2/2 <DOM>

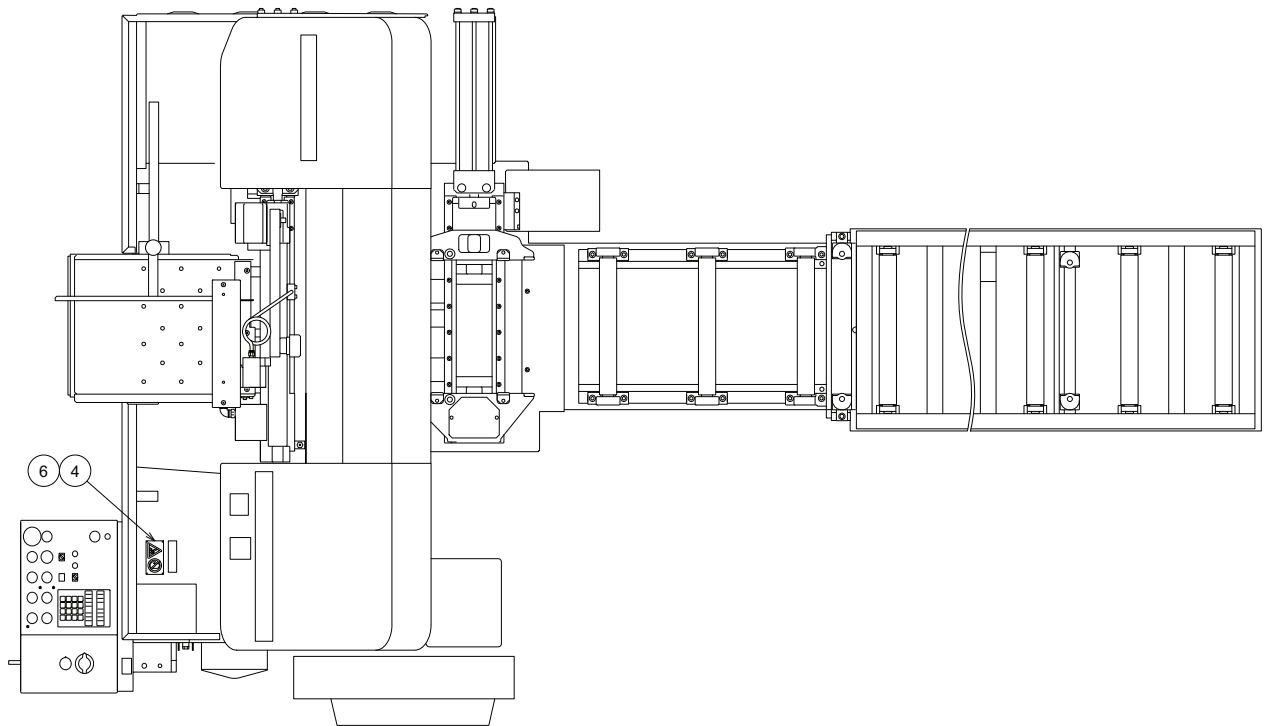

VIEW A

Unit No. 3
Name Plate(3)

| Index | Code | Parts Name | Drawing No. | Type | Maker | Q'ty | Note |
|-------|----------|---------------|-------------|----------|-------------|------|------|
| 1 | 10301133 | Warning Plate | RB0376631- | | | 1 | |
| 2 | 10301557 | Warning Plate | RB0376611- | | | 1 | |
| 3 | 10301131 | Warning Plate | RB0376621- | | | 1 | |
| 4 | 10301134 | Warning Plate | RB0376641- | | | 1 | |
| 5 | 10301129 | Warning Plate | RB0376601- | | | 1 | |
| 6 | 10345260 | Blind Rivet | P339208002 | NSA3-2 | LOBTEX | 12 | |
| 7 | 10375027 | Drive Screw | P339100002 | NO.2X4.8 | Tokyo Byora | 8 | |

Unit No. 4
Name Plate(4) <HFA400W>

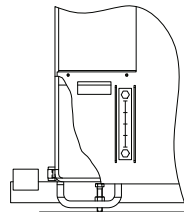
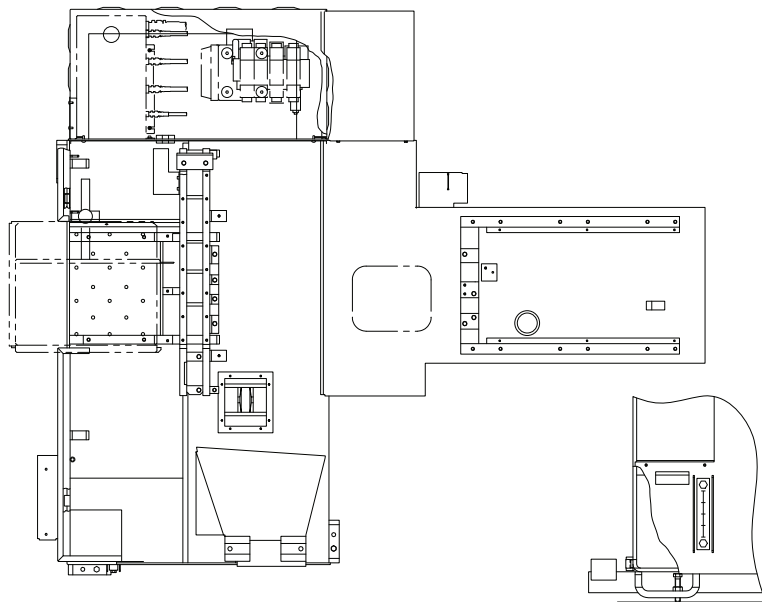
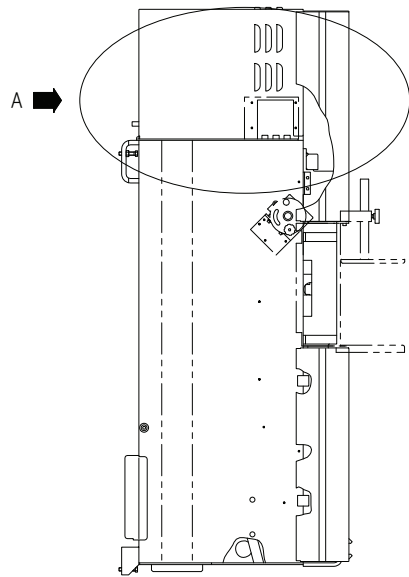

DETAIL B

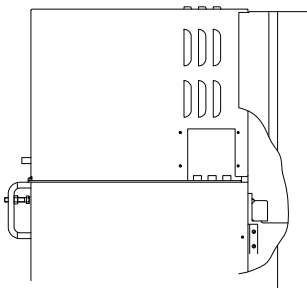

DETAIL A

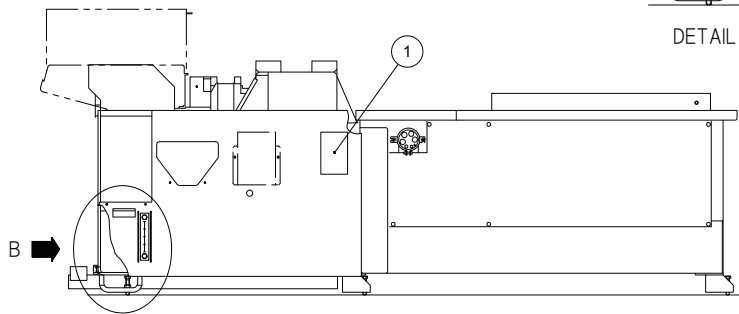

B

1

1278770--A

Unit No. 4
Name Plate(4)

| Index | Code | Parts Name | Drawing No. | Type | Maker | Q'ty | Note |
|-------|----------|--------------|-------------|------|-------|------|------|
| 1 | 10302021 | Serial Plate | RB02368--A | | | 1 | |

Unit No. 5
Name Plate(5)-1/3 <US>

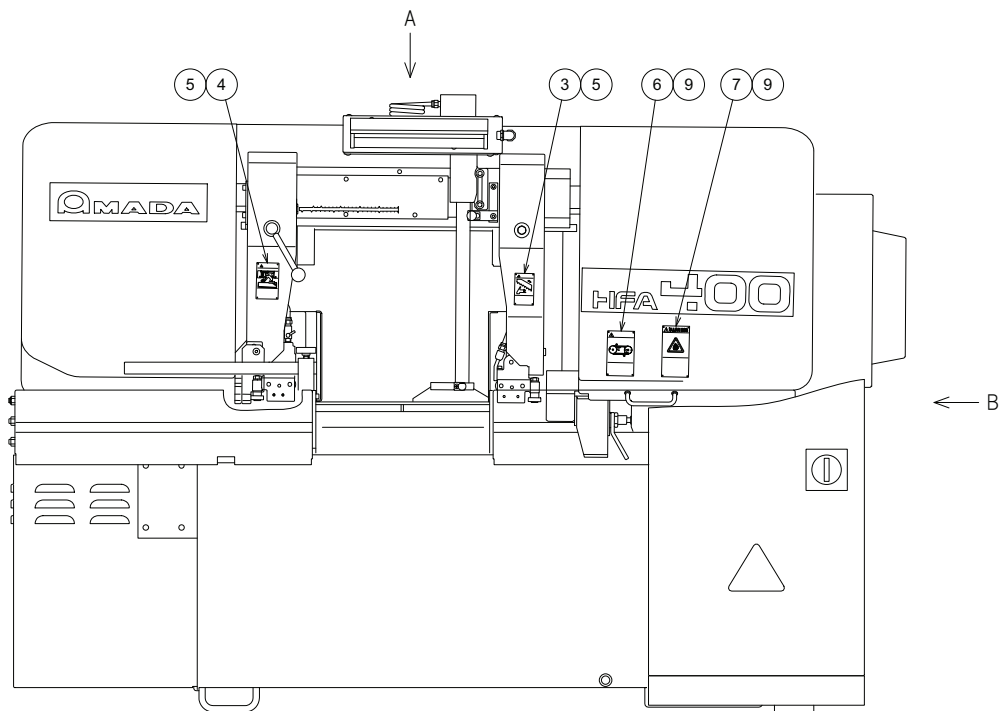

Unit No. 5
Name Plate(5)-2/3 <US>

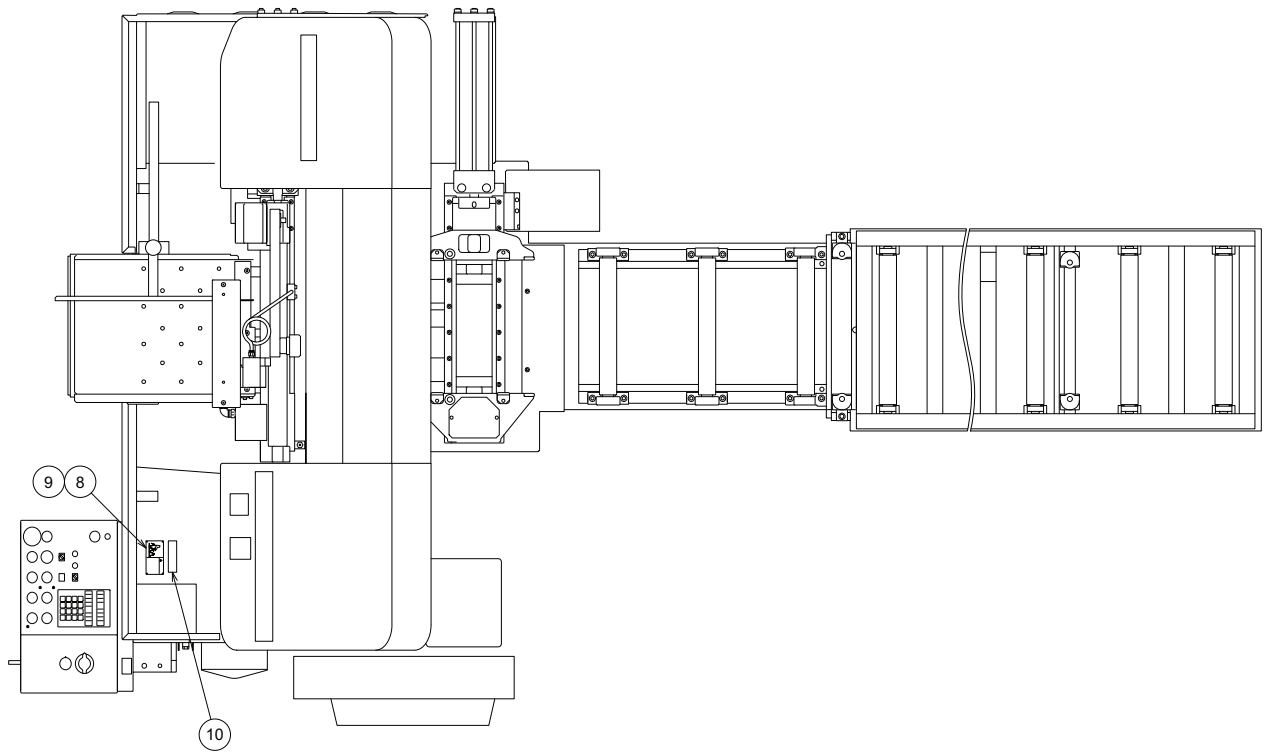

VIEW A

Unit No. 5
Name Plate(5)-3/3 <US>

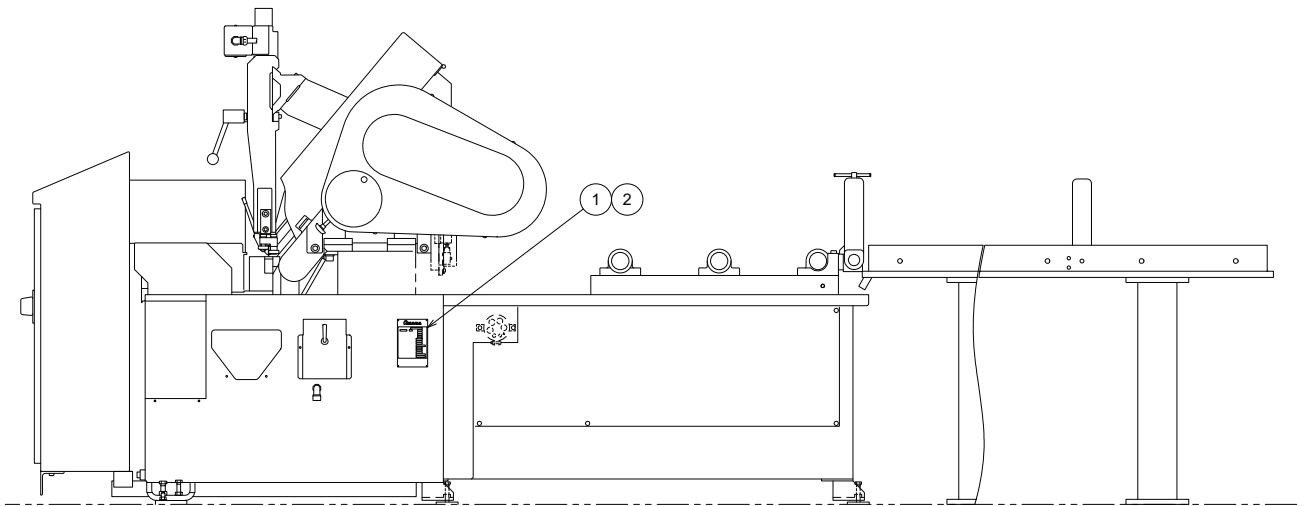

VIEW B

RB02471---

Unit No. 5
Name Plate(5)

| Index | Code | Parts Name | Drawing No. | Type | Maker | Q'ty | Note |
|-------|----------|---------------|-------------|----------|-------------|------|----------|
| 1 | 10301999 | Serial Plate | RB01717--- | | | 1 | for 34mm |
| 1 | 10302022 | Serial Plate | RB02369--- | | | 1 | for 41mm |
| 2 | 10375027 | Drive Screw | P339100002 | NO.2X4.8 | Tokyo Byora | 4 | |
| 3 | 10301558 | Warning Plate | RB0376612- | | | 1 | |
| 4 | 10301132 | Warning Plate | RB0376622- | | | 1 | |
| 5 | 10375027 | Drive Screw | P339100002 | NO.2X4.8 | Tokyo Byora | 8 | |
| 6 | 10301490 | Warning Plate | RB02212--- | | | 1 | |
| 7 | 10301130 | Warning Plate | RB0376602- | | | 1 | |
| 8 | 10301135 | Warning Plate | RB0376642- | | | 1 | |
| 9 | 10345260 | Blind Rivet | P339208002 | NSA3-2 | LOBTEX | 12 | |
| 10 | 10300877 | Caution Plate | RB00871--- | | | 1 | |

Unit No. 6
Name Plate(6)-1/3 <EU>

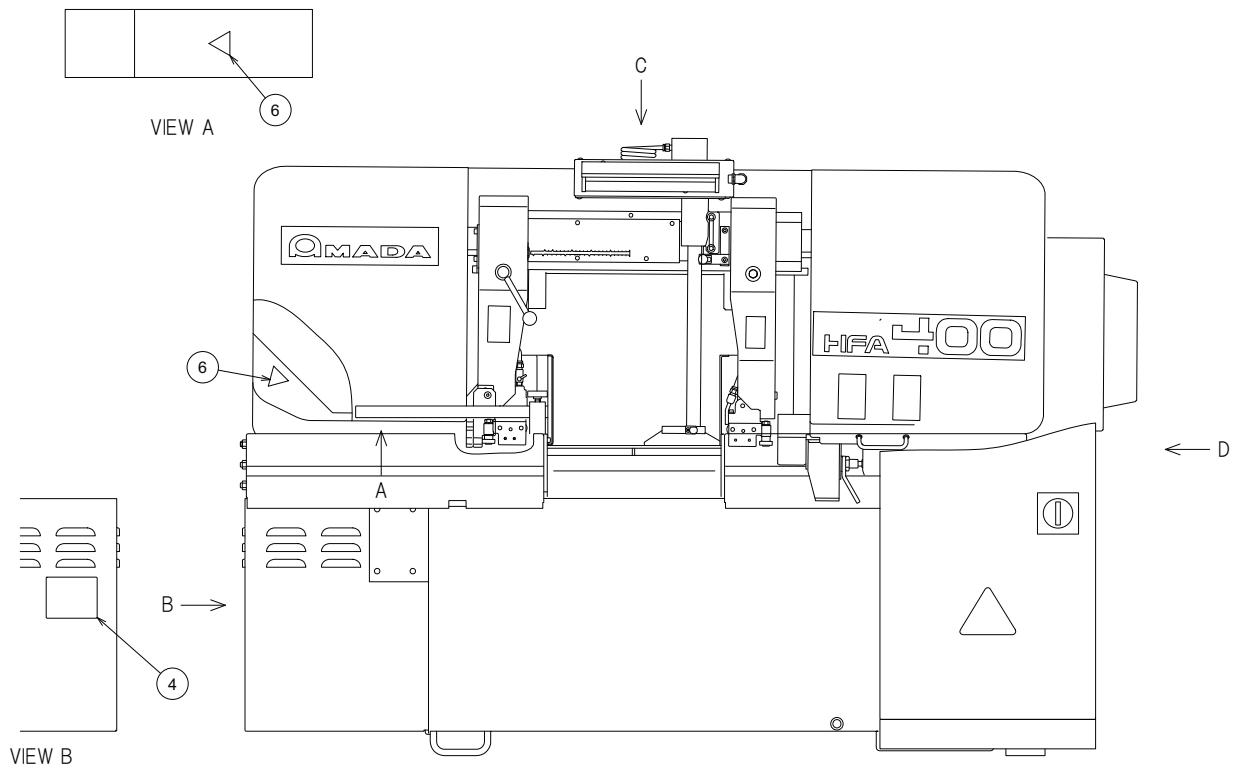

RB02472---

Unit No. 6
Name Plate(6)-2/3 <EU>

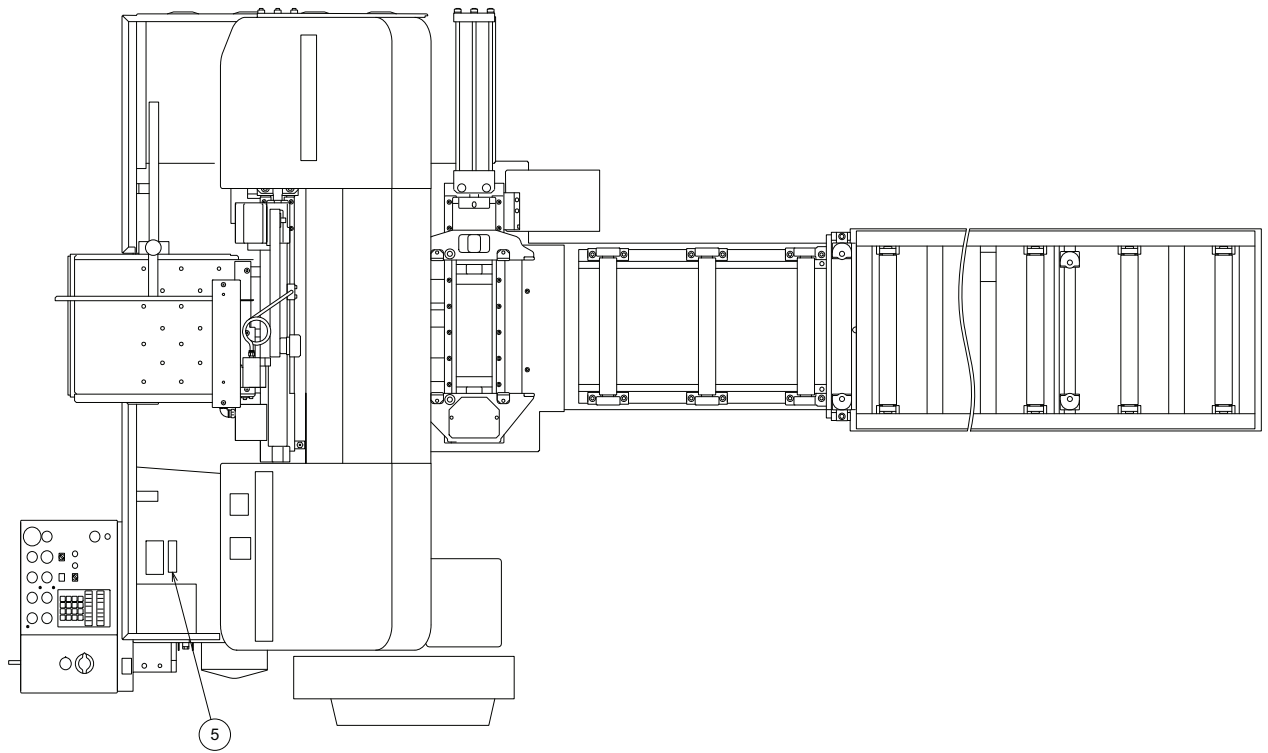

VIEW C

Unit No. 6
Name Plate(6)-3/3 <EU>

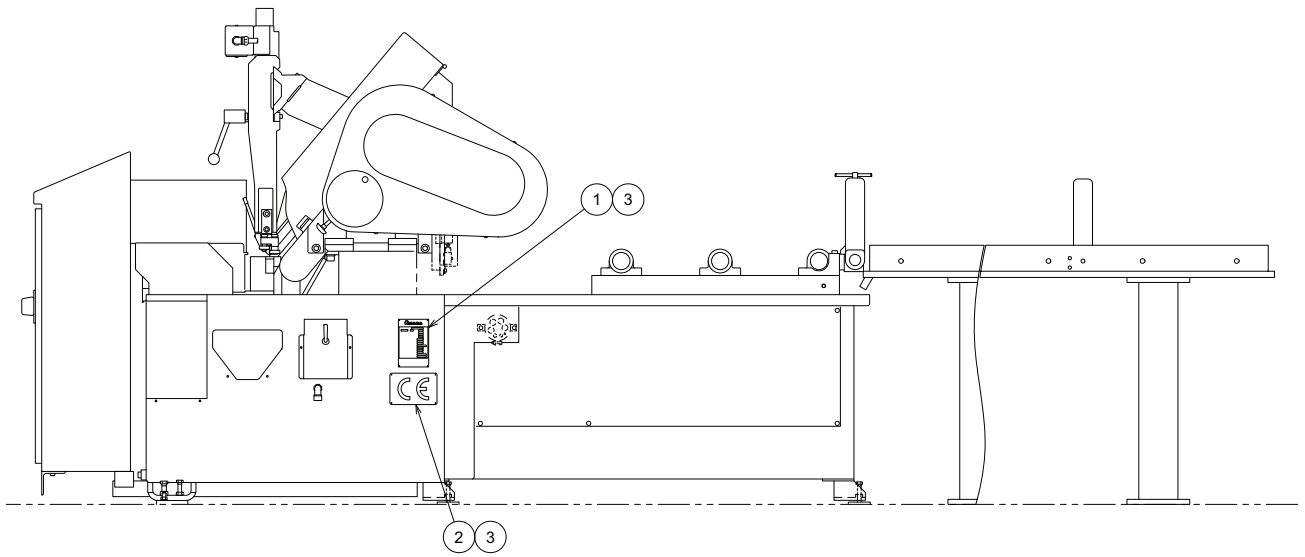

VIEW D

RB02472---

Unit No. 6
Name Plate(6)

| Index | Code | Parts Name | Drawing No. | Type | Maker | Q'ty | Note |
|-------|----------|---------------|-------------|--------------------|-------------|------|-----------|
| 1 | 10301999 | Serial Plate | RB01717--- | | | 1 | for 34mm |
| 1 | 10302022 | Serial Plate | RB02369--- | | | 1 | for 41mm |
| 2 | 10376479 | CE Mark Plate | 1279130 | | | 1 | |
| 3 | 10375027 | Drive Screw | P339100002 | NO.2X4.8 | Tokyo Byora | 8 | |
| 4 | 10301166 | Caution Plate | 1230982 | | | 1 | |
| 5 | 10376769 | Sticker | 1106982 | | | 1 | List Only |
| 6 | 10301179 | Seal | 124469735 | PRE-K005 78mmX78mm | | 2 | |

Unit No. 7
Name Plate(7)-1/3 <AS>

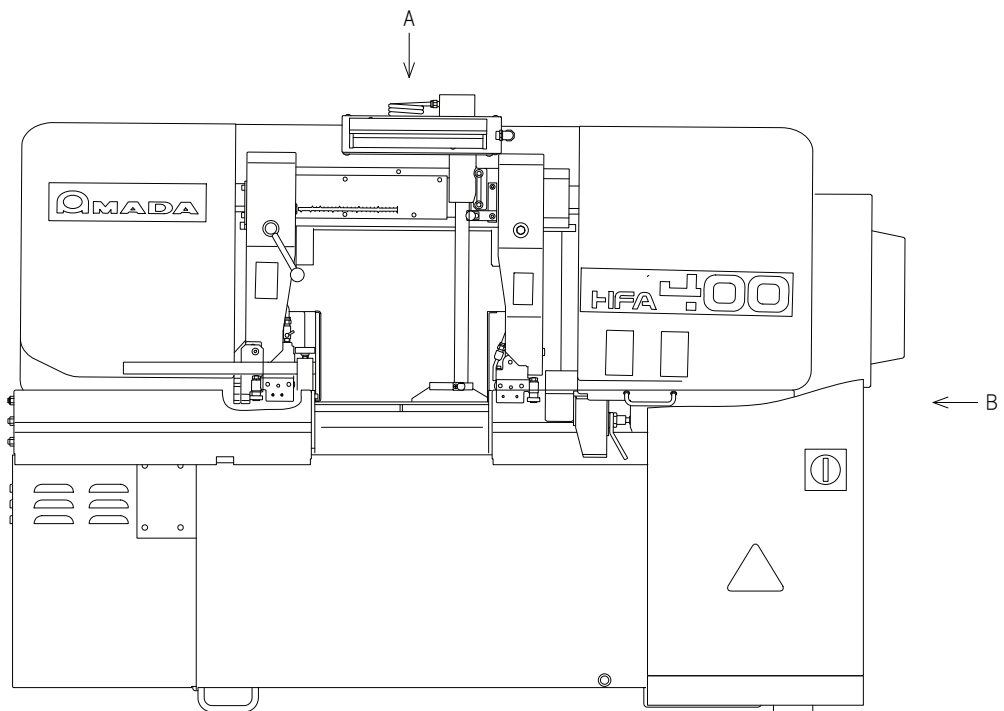

Unit No. 7
Name Plate(7)-2/3 <AS>

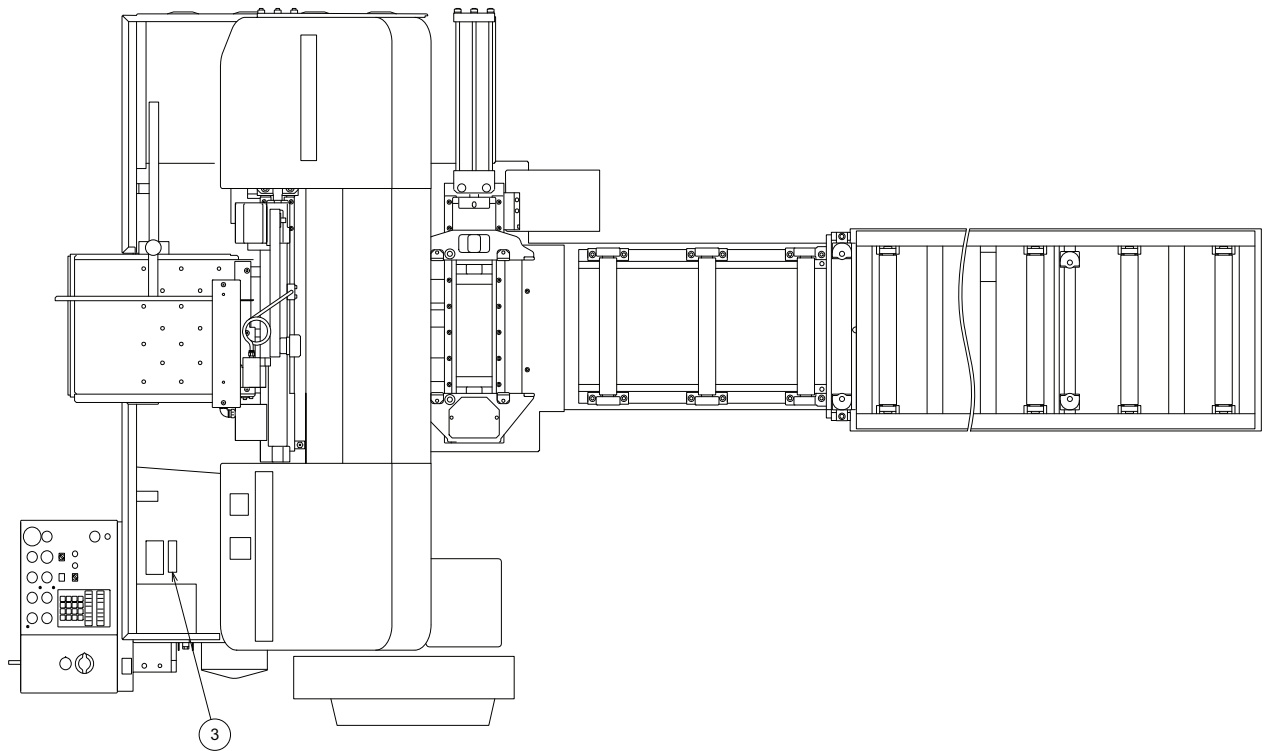

VIEW A

Unit No. 7
Name Plate(7)-3/3 <AS>

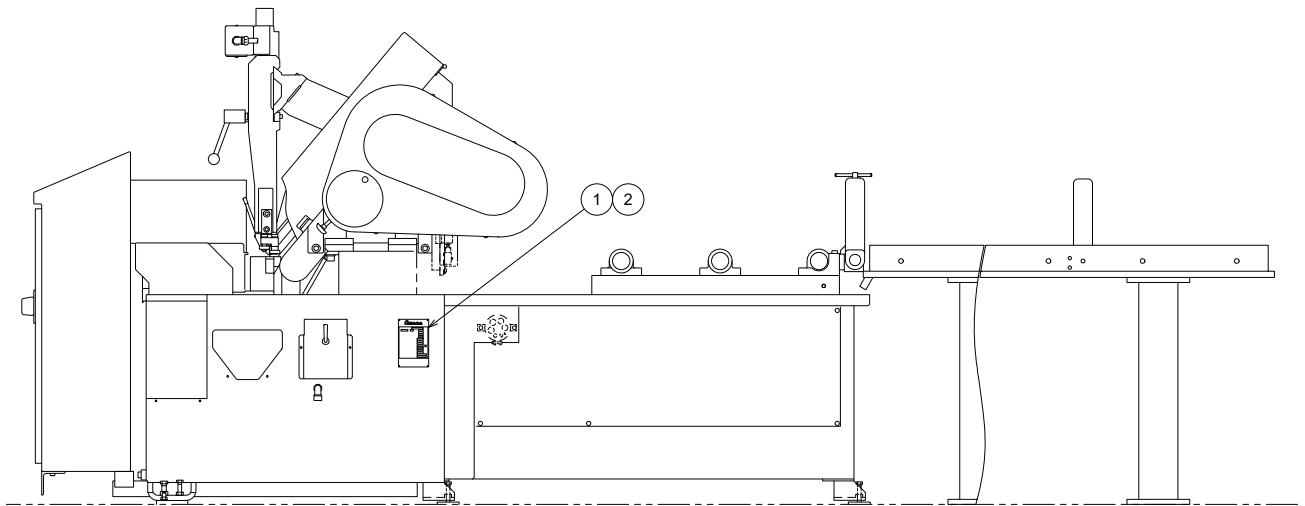

VIEW B

RB02473---

Unit No. 7
Name Plate(7)

| Index | Code | Parts Name | Drawing No. | Type | Maker | Q'ty | Note |
|-------|----------|---------------|-------------|----------|-------------|------|----------|
| 1 | 10301999 | Serial Plate | RB01717--- | | | 1 | for 34mm |
| 1 | 10302022 | Serial Plate | RB02369--- | | | 1 | for 41mm |
| 2 | 10375027 | Drive Screw | P339100002 | NO.2X4.8 | Tokyo Byora | 4 | |
| 3 | 10300877 | Caution Plate | RB00871--- | | | 1 | |

Unit No. 8
Name Plate(8)-1/3 <CHI>

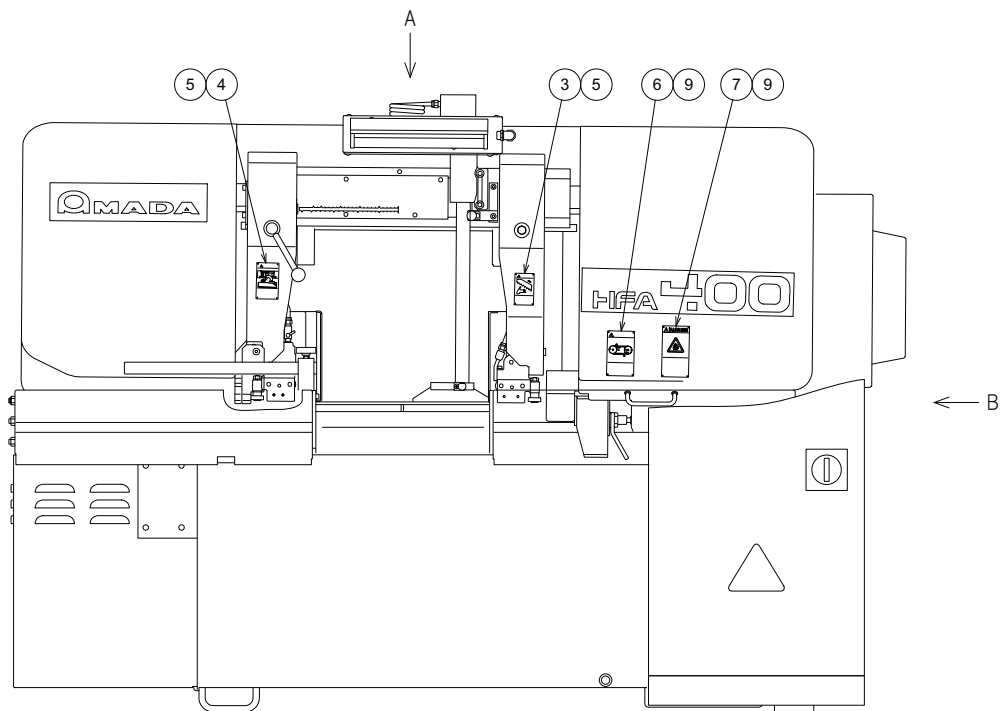

Unit No. 8
Name Plate(8)-2/3 <CHI>

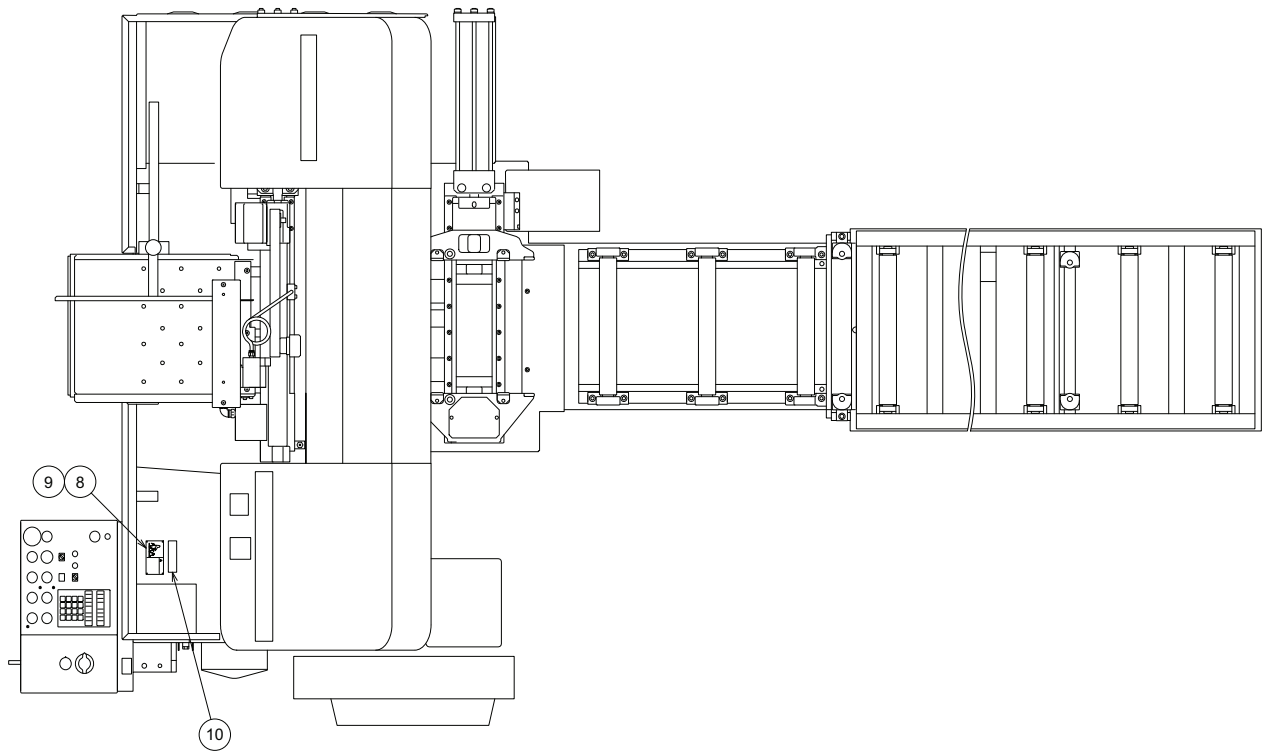

VIEW A

Unit No. 8
Name Plate(8)-3/3 <CHI>

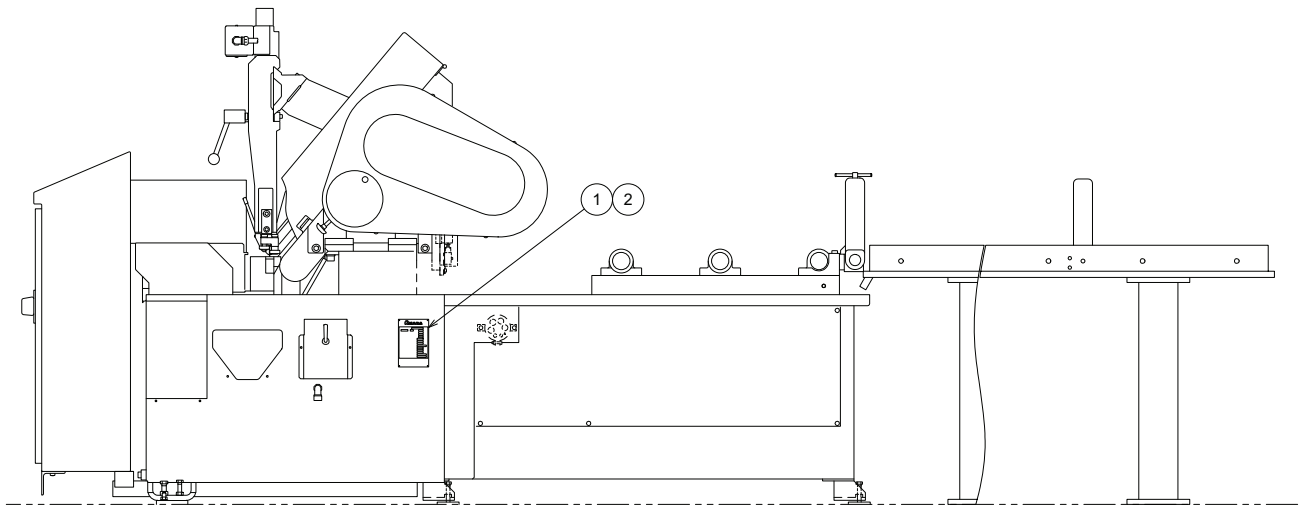

VIEW B

RB02474---

Unit No. 8
Name Plate(8)

| Index | Code | Parts Name | Drawing No. | Type | Maker | Q'ty | Note |
|-------|----------|---------------|-------------|----------|-------------|------|----------|
| 1 | 10302000 | Serial Plate | RB01718--B | | | 1 | for 34mm |
| 1 | 10302003 | Serial Plate | RB01719--B | | | 1 | for 41mm |
| 2 | 10375027 | Drive Screw | P339100002 | NO.2X4.8 | Tokyo Byora | 4 | |
| 3 | 10301147 | Warning Plate | 1205087 A | | | 1 | |
| 4 | 10300086 | Warning Plate | 1109435 | | | 1 | |
| 5 | 10375027 | Drive Screw | P339100002 | NO.2X4.8 | Tokyo Byora | 8 | |
| 6 | 10301491 | Warning Plate | RB02213--- | | | 1 | |
| 7 | 10300088 | Warning Plate | 1109441 | | | 1 | |
| 8 | 10300089 | Warning Plate | 1109442 | | | 1 | |
| 9 | 10345260 | Blind Rivet | P339208002 | NSA3-2 | LOBTEX | 12 | |
| 10 | 10300090 | Sticker | 1109443 | | | 1 | |

Unit No. 9
 Machine Body(1)-1/2 <Oil Pan>

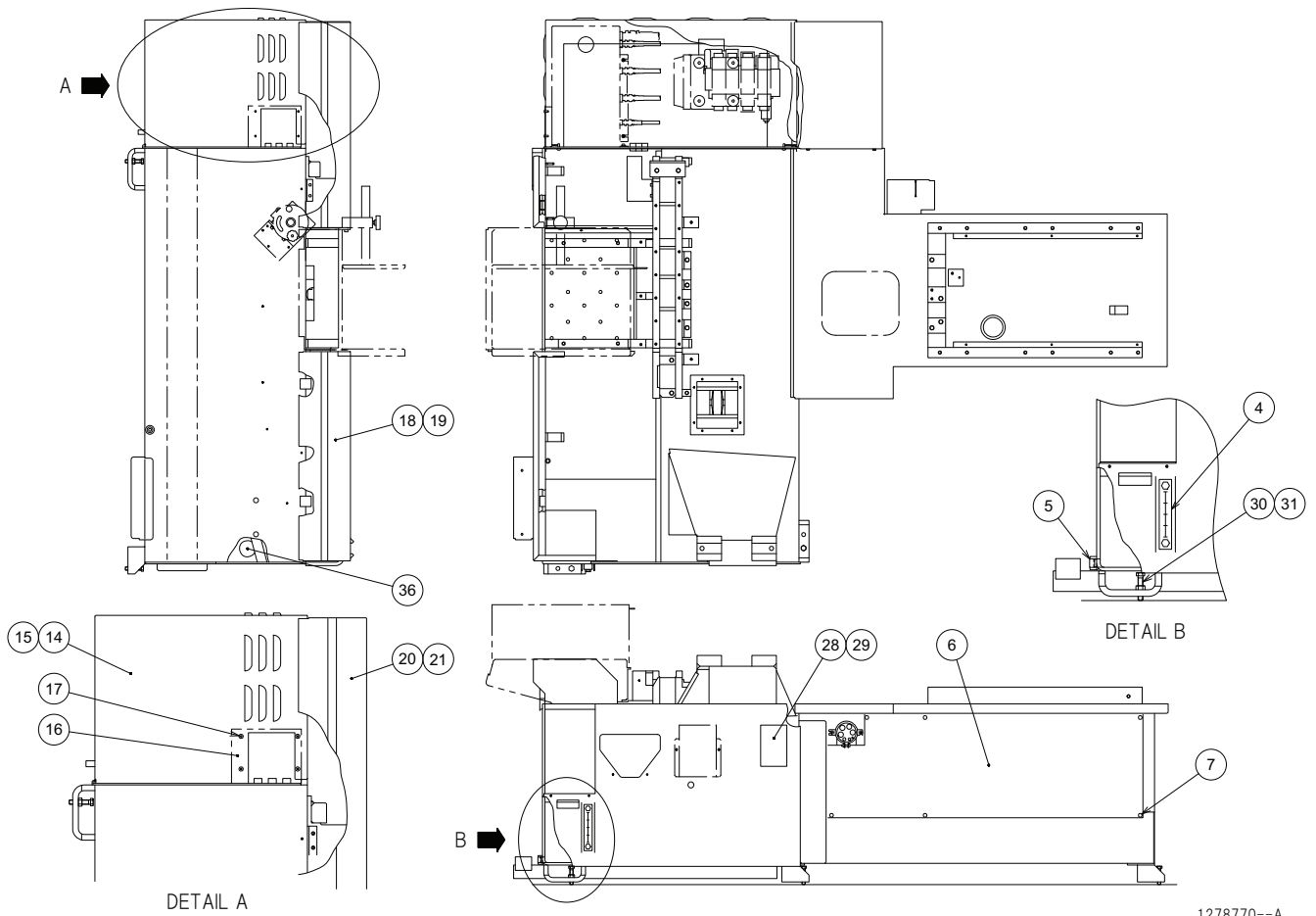

1278770--A

Unit No. 9
Machine Body(1)-2/2 <Oil Pan>

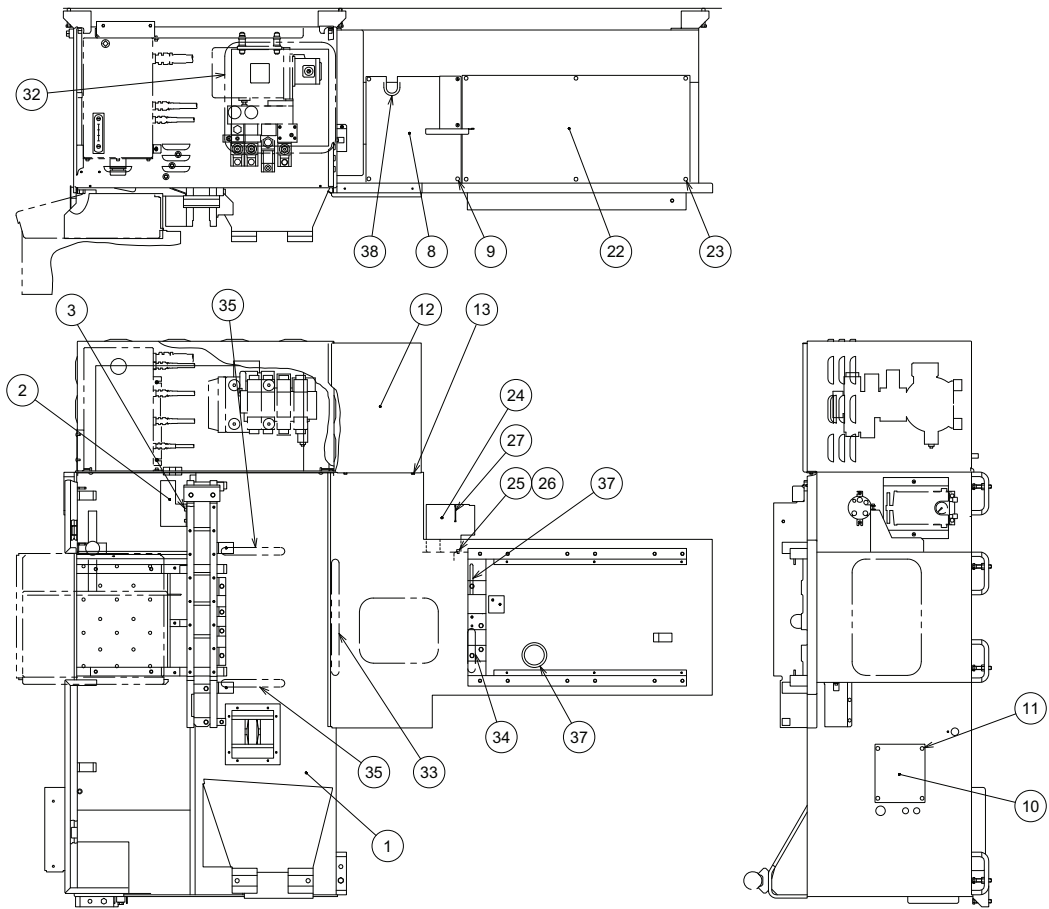

Unit No. 9
Machine Body(1)

| Index | Code | Parts Name | Drawing No. | Type | Maker | Q'ty | Note |
|-------|----------|-------------------------|-------------|---------------------|-------|------|------|
| 1 | 10301385 | Oil Pan | RB01704--C | | | 1 | |
| 2 | 10378016 | Hose Cover | 1238059 | | | 1 | |
| 3 | 10323201 | Hex Socket Cap Screw | P330220004 | M6X12 | JIS | 2 | |
| 4 | 10383587 | Level Gauge | P600108032 | KLA-140A(Float Red) | KYOWA | 1 | |
| 5 | 10322231 | Plug for Piping | P580180004 | 1/2 | | 1 | |
| 6 | 10583571 | Rear Side Cover RH | 1230567 A | | | 1 | |
| 7 | 10340019 | Truss Head Screw | P334130012 | M6X12 | JIS | 7 | |
| 8 | 10583572 | Rear Side Cover LH | 1230566 B | | | 1 | |
| 9 | 10340019 | Truss Head Screw | P334130012 | M6X12 | JIS | 3 | |
| 10 | 10321749 | Rear Cover | 1230032 A | | | 1 | |
| 11 | 10340019 | Truss Head Screw | P334130012 | M6X12 | JIS | 4 | |
| 12 | 10583573 | Safety Cover | 1230071 | | | 1 | |
| 13 | 10325407 | Bolt | P330020003 | M6X12 | JIS | 2 | |
| 14 | 10419301 | Auxiliary Oil Pan Cover | 1238524 A | | | 1 | |
| 15 | 10322133 | Truss Head Screw | P334130014 | M6X20 | JIS | 2 | |
| 16 | 10321958 | Cover | 1230040 | | | 1 | |
| 17 | 10340019 | Truss Head Screw | P334130012 | M6X12 | JIS | 4 | |
| 18 | 10301386 | Splash Guard R | RB01712--B | | | 1 | |
| 19 | 10340019 | Truss Head Screw | P334130012 | M6X12 | JIS | 1 | |

Unit No. 9
Machine Body(1)

| Index | Code | Parts Name | Drawing No. | Type | Maker | Q'ty | Note |
|-------|----------|----------------------|-------------|--------------------|-------------|------|------|
| 20 | 10301387 | Splash Guard L | RB01713--A | | | 1 | |
| 21 | 10340019 | Truss Head Screw | P334130012 | M6X12 | JIS | 1 | |
| 22 | 10583574 | Cover | 1230584 A | | | 1 | |
| 23 | 10340019 | Truss Head Screw | P334130012 | M6X12 | JIS | 6 | |
| 24 | 10583575 | Hose Support | 1230644 B | | | 1 | |
| 25 | 10589206 | Hex Socket Cap Screw | P330220003 | M6X10 | | 2 | |
| 26 | 10321922 | Washer | P336000005 | 6(Normal) | JIS | 2 | |
| 27 | 10375463 | Cable Band | P381058035 | SKB-2M | KITAGAWA | 1 | |
| 28 | 10301998 | Serial Plate | RB01716--A | | | 1 | |
| 29 | 10375027 | Drive Screw | P339100002 | NO.2X4.8 | Tokyo Byora | 4 | |
| 30 | 10343764 | Bolt | P330050011 | M12X60(All-thread) | MOURI | 6 | |
| 31 | 10589227 | Nut | P332000007 | M12 | JIS | 6 | |
| 32 | 10301317 | Flexible Conduit | P869028113 | CTUB22-1.55M | MISUMI | 1 | |
| 33 | 10301318 | Flexible Conduit | P869028114 | CTUB22-1.25M | MISUMI | 1 | |
| 34 | 10301319 | Flexible Conduit | P869028115 | CTUB22-0.75M | MISUMI | 1 | |
| 35 | 10583173 | Flexible Conduit | P869028085 | CTUB22-0.6M | MISUMI | 2 | |
| 36 | 10301320 | Flexible Conduit | P869028120 | CTUB13-0.23M | MISUMI | 1 | |
| 37 | 10301315 | Flexible Conduit | P869028105 | CTUB7-0.3M | MISUMI | 2 | |
| 38 | 10301316 | Flexible Conduit | P869028111 | CTUB7-0.2M | MISUMI | 1 | |

Unit No. 10
Machine Body(2) <EU Specification Machine>

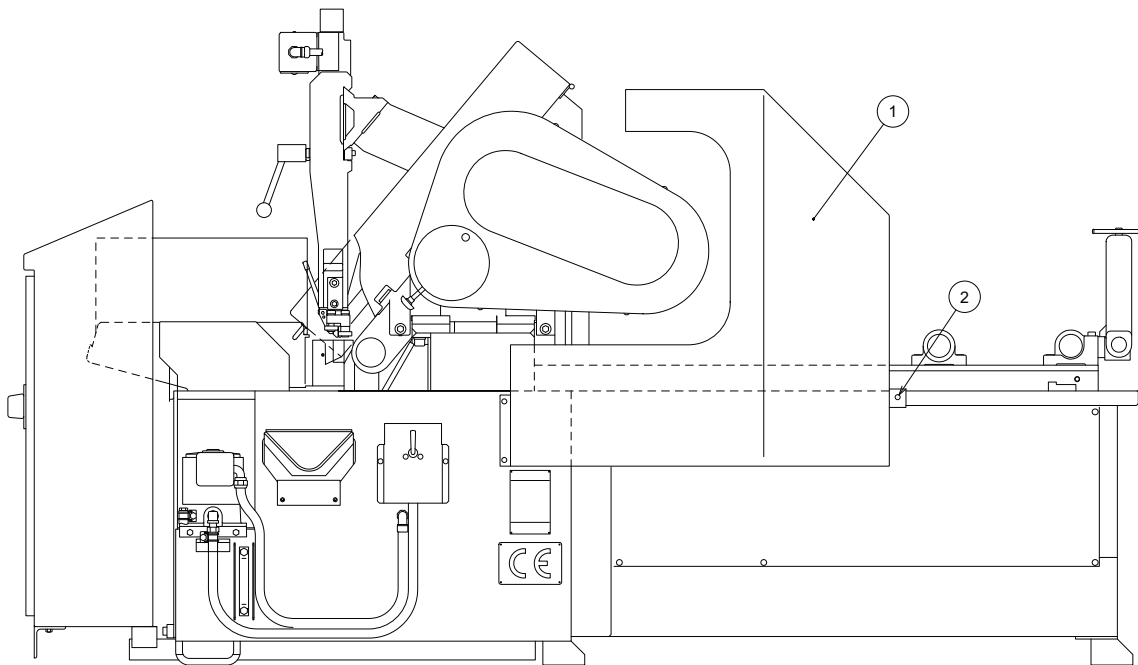

1230340

Unit No. 10
Machine Body(2)

| Index | Code | Parts Name | Drawing No. | Type | Maker | Q'ty | Note |
|-------|----------|------------------|-------------|-------|-------|------|------|
| 1 | 10301161 | Safety Cover | 1230974 | | | 1 | |
| 2 | 10385708 | Truss Head Screw | P334130011 | M6X10 | JIS | 3 | |

Unit No. 11
Machine Body(3)-1/2 <Hinge>

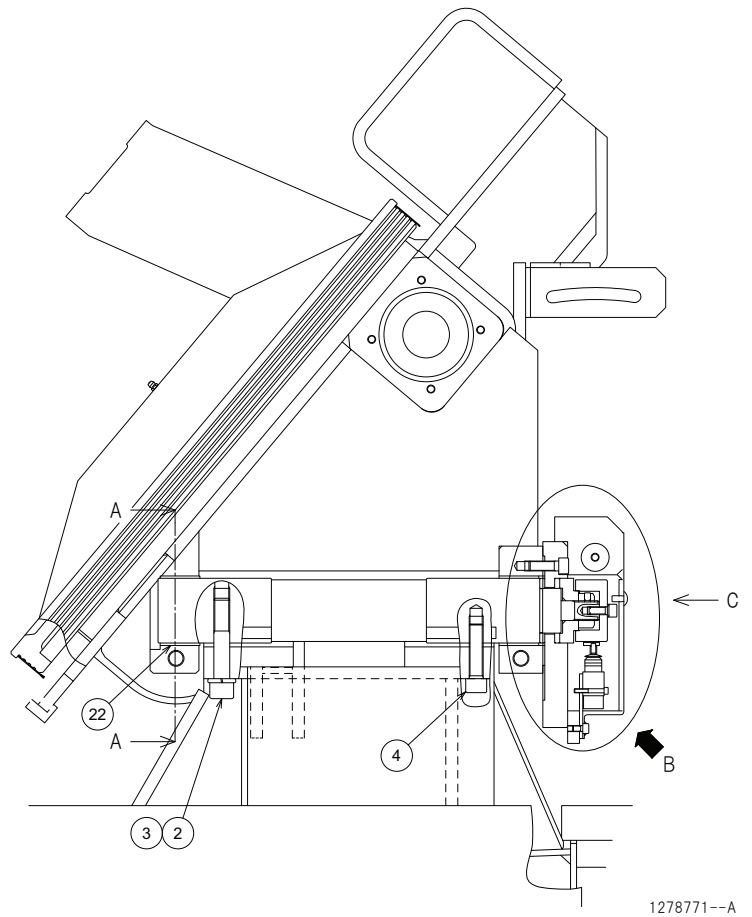
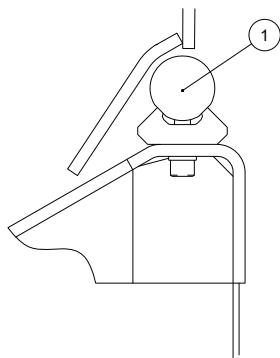
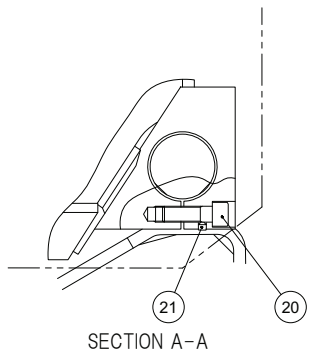

Unit No. 11
Machine Body(3)-2/2 <Hinge>

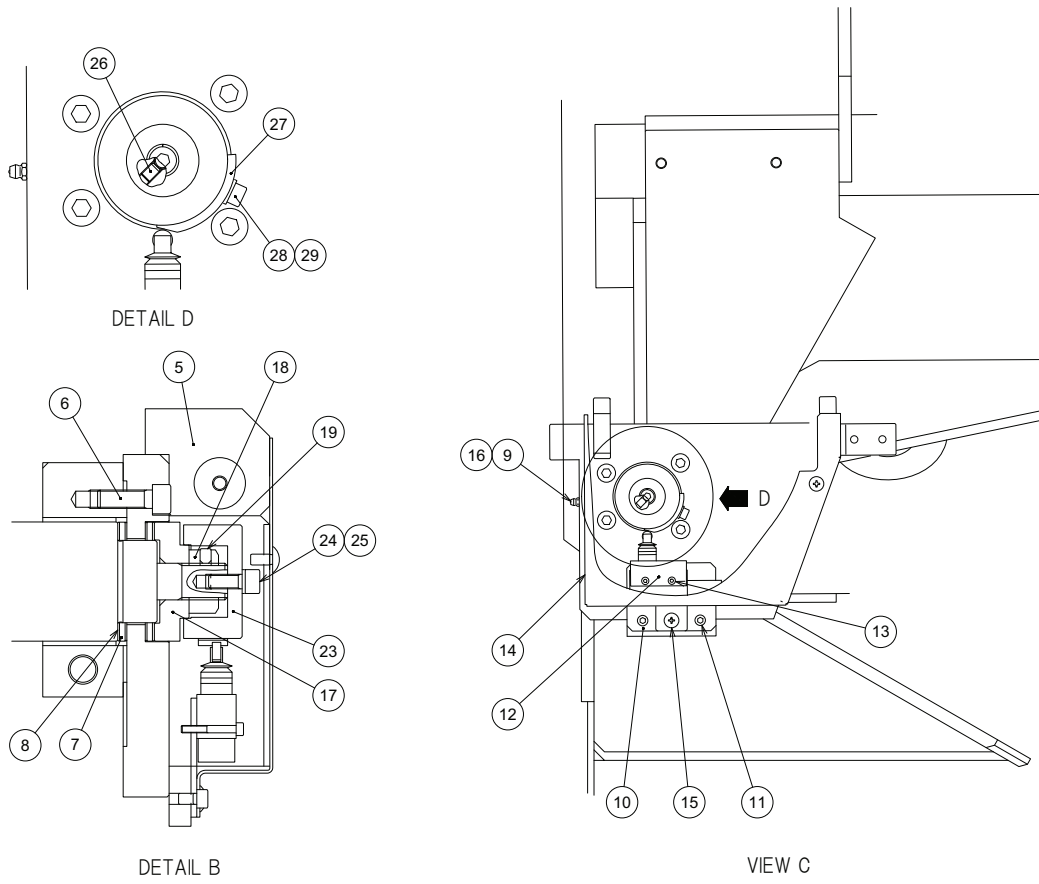

Unit No. 11
Machine Body(3)

| Index | Code | Parts Name | Drawing No. | Type | Maker | Q'ty | Note |
|-------|----------|-----------------------|-------------|------------------------|-------|------|------|
| 1 | 10419307 | Hinge Pin | 1238030 B | | | 1 | |
| 2 | 10583225 | Reamer Bolt L | 1230017 C | | | 1 | |
| 3 | 10583578 | Conical Spring Washer | 124469718 | | | 1 | |
| 4 | 10322210 | Hex Socket Cap Screw | P330260009 | M14X55 | JIS | 1 | |
| 5 | 10301388 | Bearing Support | RB01723--A | | | 1 | |
| 6 | 10322207 | Hex Socket Cap Screw | P330240008 | M10X30 | | 4 | |
| 7 | 10322146 | Roller Bearing | P402107001 | FNTA-4565 | NSK | 2 | |
| 8 | 10322147 | Bearing Ring | P406127001 | FTRA-4565 | NSK | 4 | |
| 9 | 10419913 | Grease Nipple | P560600002 | A-MT6X1 | JIS | 1 | |
| 10 | 10583580 | LS Bracket | 1230602 A | | | 1 | |
| 11 | 10589206 | Hex Socket Cap Screw | P330220003 | M6X10 | | 2 | |
| 12 | 10348515 | Limit Switch | P828012017 | ZC-N2255 | OMRON | 1 | |
| 13 | 10359526 | Hex Socket Cap Screw | P330200023 | M4X30 | | 2 | |
| 14 | 10301389 | Cover | RB01725--A | | | 1 | |
| 15 | 10340019 | Truss Head Screw | P334130012 | M6X12 | JIS | 3 | |
| 16 | 10323010 | Name Plate | 0852250 | | | 1 | |
| 17 | 10378035 | Bearing Cap | 1238032 | | | 1 | |
| 18 | 10321966 | Nut | 0603150 | M20 (Type-1) Add Works | | 1 | |
| 19 | 10322120 | Socket Set Screw | P330590018 | M6X8(Dimple Type) | JIS | 1 | |

Unit No. 11
Machine Body(3)

| Index | Code | Parts Name | Drawing No. | Type | Maker | Q'ty | Note |
|-------|----------|-----------------------|-------------|-------------------|-------------|------|------|
| 20 | 10322205 | Hex Socket Cap Screw | P330260034 | M16X50 | | 2 | |
| 21 | 10322125 | Socket Set Screw | P330590023 | M8X8(Dimple Type) | JIS | 2 | |
| 22 | 10583582 | Plain Bearing | P407003183 | DUB6540 | DAIDO METAL | 2 | |
| 23 | 10583583 | Dog Shaft | 1230604 C | | | 1 | |
| 24 | 10322202 | Hex Socket Cap Screw | P330230006 | M8X20 | | 1 | |
| 25 | 10589279 | Conical Spring Washer | P336165002 | CDW-8H | HHK | 1 | |
| 26 | 10329309 | Socket Set Screw | P330550025 | M6X8(Flat Type) | JIS | 1 | |
| 27 | 10378036 | Dog | 1238037 | | | 1 | |
| 28 | 10589206 | Hex Socket Cap Screw | P330220003 | M6X10 | | 1 | |
| 29 | 10301283 | Conical Spring Washer | P336040002 | 1H-6 | JIS | 1 | |

Unit No. 12
Machine Body(4)-1/2 <Front View>

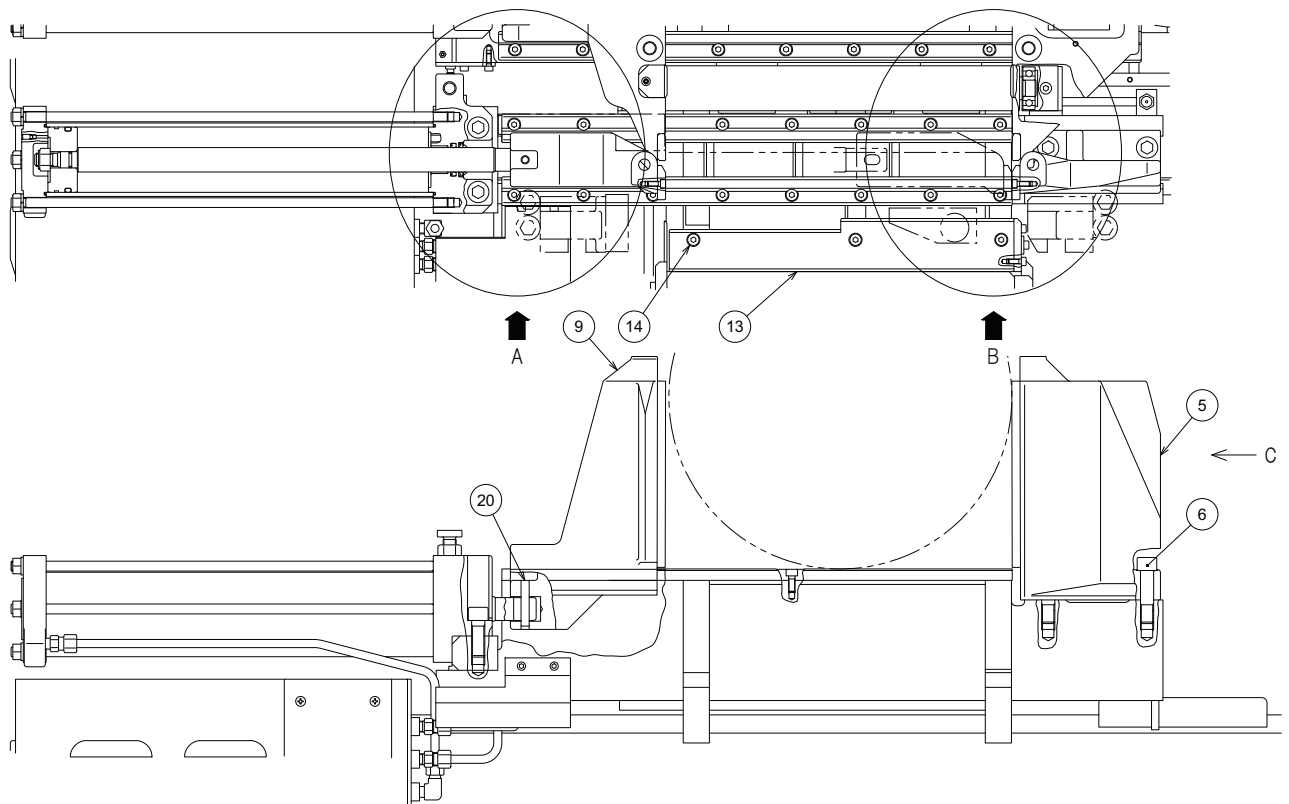

1278772--A

Unit No. 12
Machine Body(4)-2/2 <Front Vise>

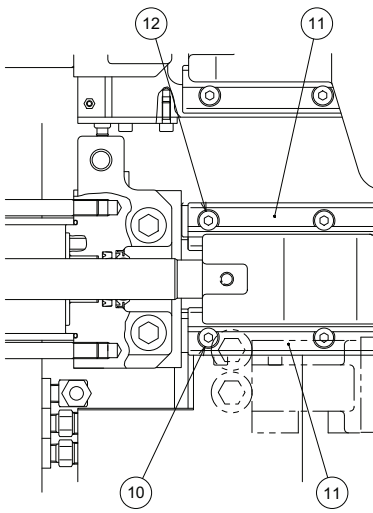

DETAIL A

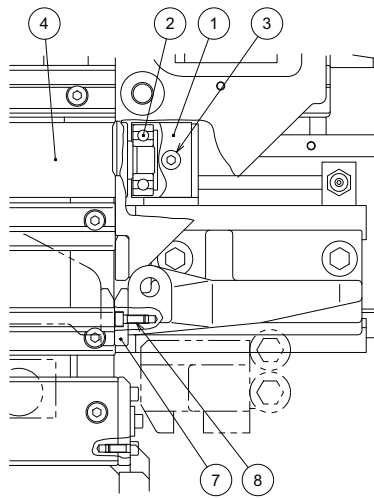

DETAIL B

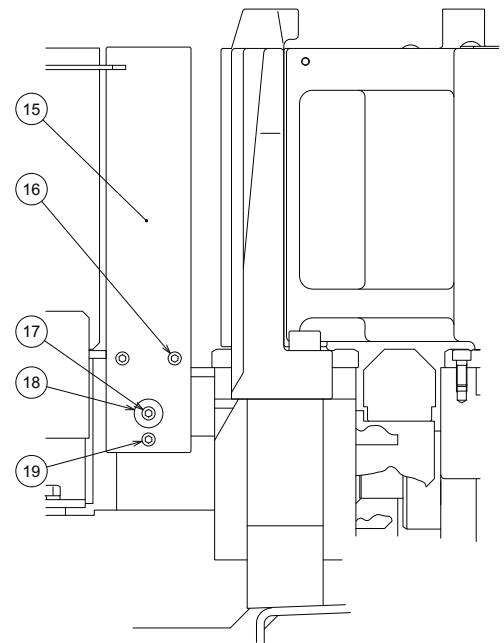

VIEW C

1278772--A

Unit No. 12
Machine Body(4)

| Index | Code | Parts Name | Drawing No. | Type | Maker | Q'ty | Note |
|-------|----------|--------------------------|-------------|-------------------|-------|------|------|
| 1 | 10376204 | Roller Bracket | 1233020 B | | | 2 | |
| 2 | 10555909 | Deep Groove Ball Bearing | P400017017 | 6304DDU | NSK | 2 | |
| 3 | 10369809 | Hex Socket Cap Screw | P330230014 | M8X60 | | 2 | |
| 4 | 10378048 | Roller | 1238488 A | | | 1 | |
| 5 | 10419311 | Stationary Vise Jaw | 1238008 A | | | 1 | |
| 6 | 10583584 | Reamer Bolt | 1108043 A | | | 2 | |
| 7 | 10378046 | Vise Plate | 1238097 A | | | 2 | |
| 8 | 10312831 | Hex Socket Cap Screw | P330220006 | M6X15 | | 8 | |
| 9 | 10419312 | Movable Vise Jaw | 1238009 B | | | 1 | |
| 10 | 10322202 | Hex Socket Cap Screw | P330230006 | M8X20 | | 8 | |
| 11 | 10386018 | Slide Plate | 1238479 C | | | 2 | |
| 12 | 10322202 | Hex Socket Cap Screw | P330230006 | M8X20 | | 8 | |
| 13 | 10378031 | Work Receiver | 1238028 | | | 1 | |
| 14 | 10322202 | Hex Socket Cap Screw | P330230006 | M8X20 | | 3 | |
| 15 | 10378032 | Work Stopper Plate | 1238029 A | | | 1 | |
| 16 | 10312831 | Hex Socket Cap Screw | P330220006 | M6X15 | | 2 | |
| 17 | 10324622 | Hex Socket Cap Screw | P330220011 | M6X25 | | 1 | |
| 18 | 10321921 | Washer | 1230039 | | | 1 | |
| 19 | 10322126 | Socket Set Screw | P330550049 | M10X12(Flat Type) | JIS | 1 | |

Unit No. 12
Machine Body(4)

| Index | Code | Parts Name | Drawing No. | Type | Maker | Q'ty | Note |
|-------|----------|------------|-------------|---------|--------|------|------|
| 20 | 10322112 | Spring Pin | P337030096 | 10X60AW | OHKITA | 1 | |

Unit No. 13
Machine Body(5) <Vise Cylinder>

1 Index 2-21

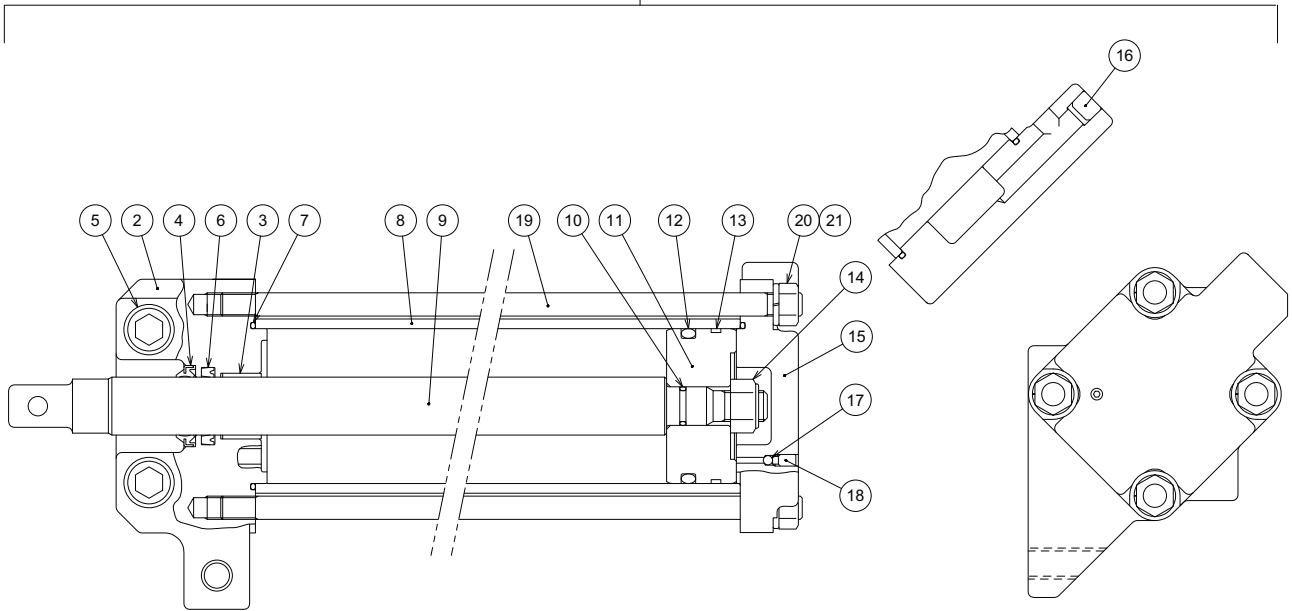

1278773--A

Unit No. 13
Machine Body(5)

| Index | Code | Parts Name | Drawing No. | Type | Maker | Q'ty | Note |
|-------|----------|--------------------------|-------------|----------------|---------------|------|-----------------|
| 1 | 10302092 | Vise Cylinder ASSY | SBS0125--- | | | 1 | with Index 2-21 |
| 2 | 10301171 | Cylinder Cap F | 1238370 A | | | 1 | |
| 3 | 10300163 | Plain Bearing | P407003176 | DUB3020 | DAIDO METAL | 1 | |
| 4 | 10338202 | Wiper Ring | P590313004 | SCB-30 | SAKAGAMI | 1 | |
| 5 | 10332953 | Hex Socket Cap Screw | P330260033 | M16X45 | | 2 | |
| 6 | 10376483 | Piston Packing | P590403023 | SKY-30 | SAKAGAMI | 1 | |
| 7 | 10383406 | O Ring | P590012012 | 1A-G80 | NOK | 2 | |
| 8 | 10378290 | Cylinder | 1238366 | | | 1 | |
| 9 | 10378291 | Piston Rod | 1238367 A | | | 1 | |
| 10 | 10589448 | O Ring | P590000018 | P20 | | 1 | |
| 11 | 10378295 | Piston | 1238372 | | | 1 | |
| 12 | 10001114 | O Ring | P590000061 | P70 | | 1 | |
| 13 | 10359913 | Wearing | P590473021 | SWB-80 | SAKAGAMI | 1 | |
| 14 | 10375004 | Locking Nut | P332505010 | M16(Type-1) | FUJI SEIMITSU | 1 | |
| 15 | 10419313 | Cylinder Cap R | 1238884 A | | | 1 | |
| 16 | 10300171 | Plug for Piping | P580208021 | PT-1/4 | | 1 | |
| 17 | 10332944 | Steel Ball (for Bearing) | P406000002 | 3/16 | JIS | 1 | |
| 18 | 10356511 | Socket Set Screw | P330570017 | M6X12(Dog-end) | JIS | 1 | |
| 19 | 10419314 | Tie Rod | 1238885 | | | 4 | |

Unit No. 13
Machine Body(5)

| Index | Code | Parts Name | Drawing No. | Type | Maker | Q'ty | Note |
|-------|----------|---------------|-------------|------|-------|------|------|
| 20 | 10589227 | Nut | P332000007 | M12 | JIS | 4 | |
| 21 | 10000829 | Spring Washer | P336050008 | 12 | JIS | 4 | |

Unit No. 14
Machine Body(6) <Work Tray>

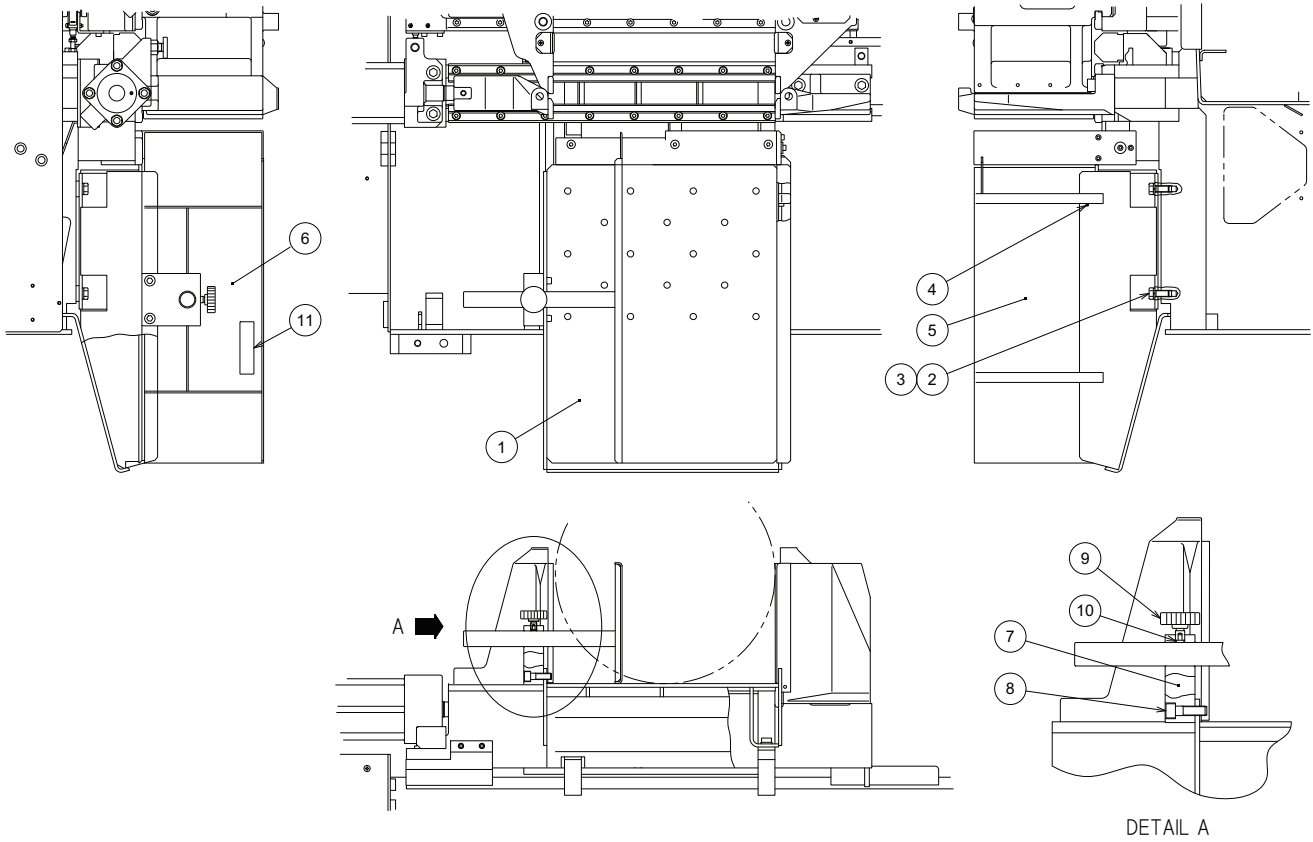

1278774--A

Unit No. 14
Machine Body(6)

| Index | Code | Parts Name | Drawing No. | Type | Maker | Q'ty | Note |
|-------|----------|-----------------------|-------------|-------------|-------|------|------|
| 1 | 10583703 | Work Tray | 1238549 B | | | 1 | |
| 2 | 10583704 | Bolt | 124469719 | M12X30 12.9 | | 4 | |
| 3 | 10583705 | Conical Spring Washer | 124469720 | | | 4 | |
| 4 | 10339616 | Spring Pin | P337030036 | 5X10AW | JIS | 1 | |
| 5 | 10583706 | Fence R | 1238546 C | | | 1 | |
| 6 | 10583707 | Fence L | 1238547 B | | | 1 | |
| 7 | 10378388 | Bracket | 1238548 A | | | 1 | |
| 8 | 10328331 | Hex Socket Cap Screw | P330250007 | M12X40 | | 2 | |
| 9 | 10301252 | Lock Handle | 1280595--A | | | 1 | |
| 10 | 10301140 | Lock Piece | 0603312--A | | | 1 | |
| 11 | 10301390 | Sticker | RB01755--A | | | 1 | |

Unit No. 15
Machine Body(7) <Control Panel Attachment>

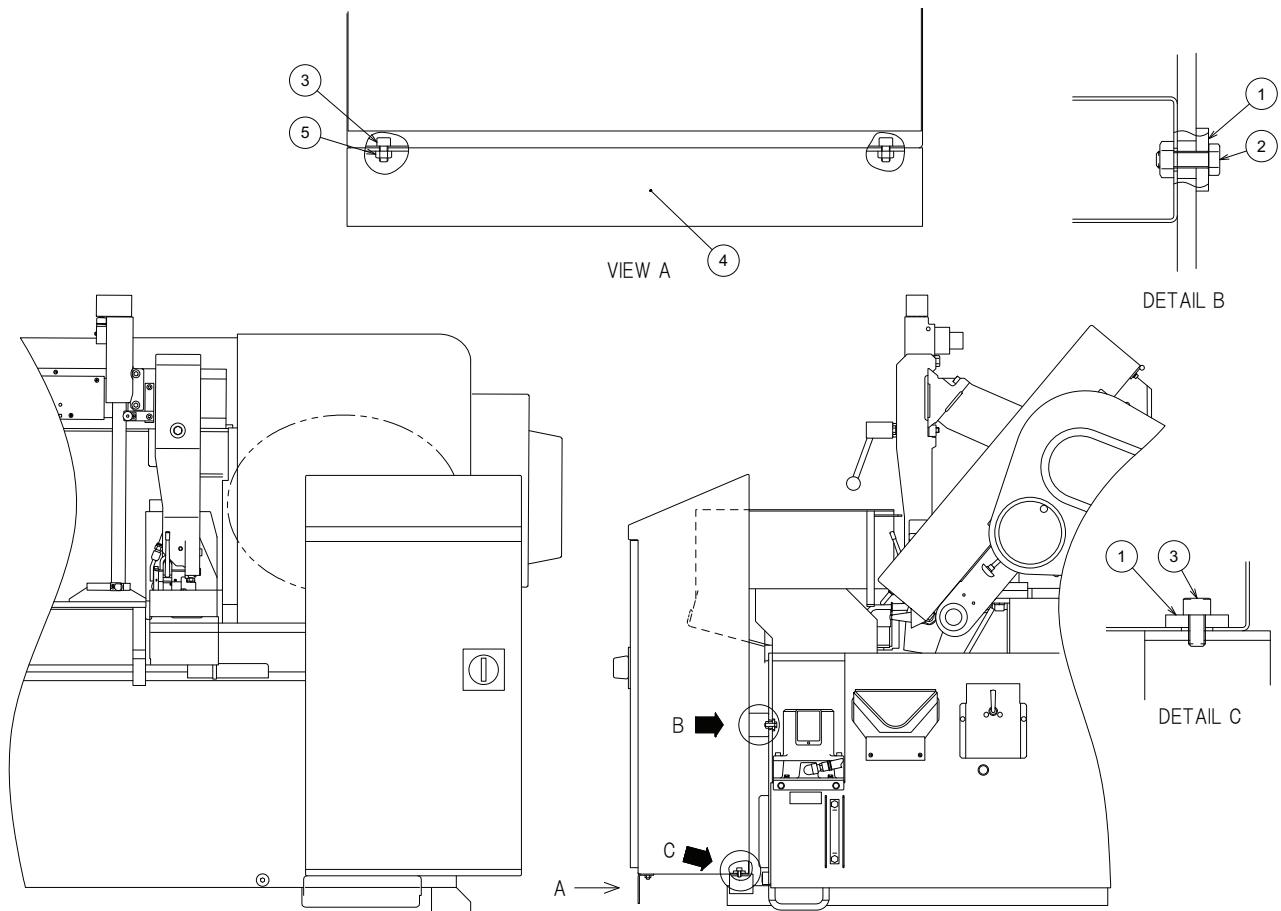

1278775--A

Unit No. 15
Machine Body(7)

| Index | Code | Parts Name | Drawing No. | Type | Maker | Q'ty | Note |
|-------|----------|----------------------|-------------|-------|-------|------|------|
| 1 | 10301146 | Washer | 1200735--A | | | 4 | |
| 2 | 10001512 | Bolt | P330030007 | M8X25 | | 2 | |
| 3 | 10342325 | Hex Socket Cap Screw | P330230004 | M8X15 | | 4 | |
| 4 | 10578709 | Cover | 1427001 | | | 1 | |
| 5 | 10589226 | Nut | P332000005 | M8 | JIS | 2 | |

Unit No. 16
Wedge-type Anchor Bolt

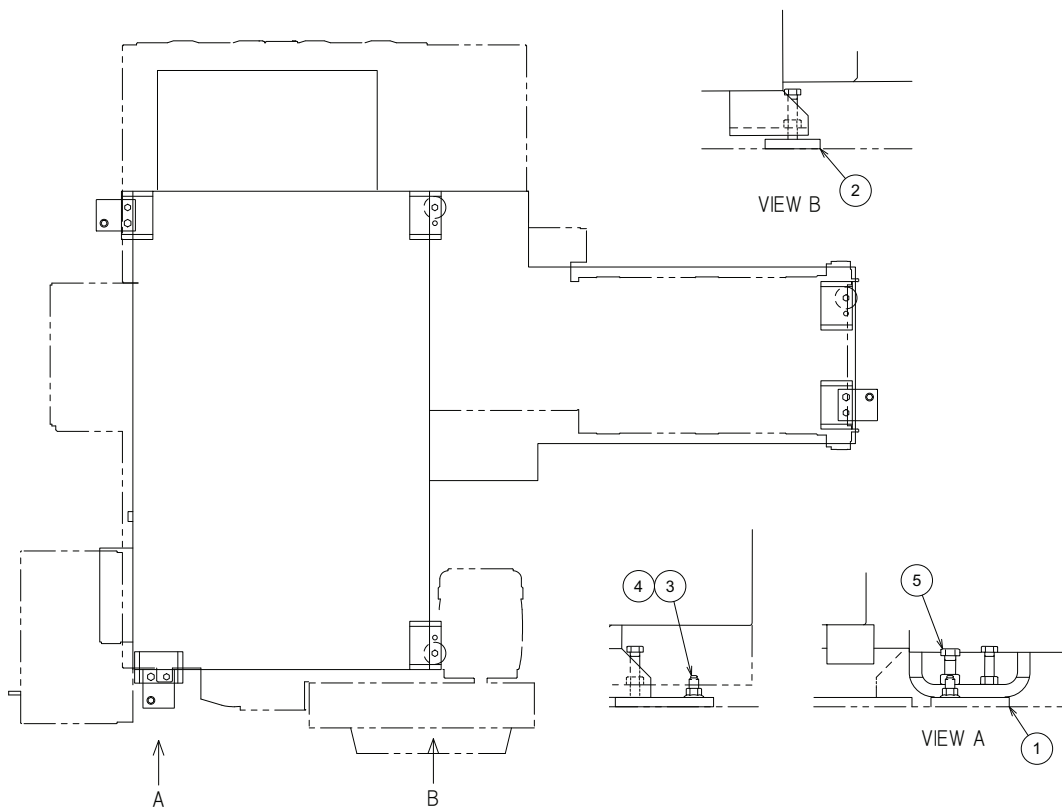

RB02485---

Unit No. 16

Wedge-type Anchor Bolt

| Index | Code | Parts Name | Drawing No. | Type | Maker | Q'ty | Note |
|-------|----------|---------------|-------------|--------------------|------------------|------|------|
| 1 | 10300960 | Anchor Plate | RB01041--- | | | 3 | |
| 2 | 10300961 | Table Support | RB01042--- | | | 3 | |
| 3 | 10376113 | Bolt | P330060009 | M14X65(All-thread) | | 3 | |
| 4 | 10000826 | Nut | P332000008 | M14 | JIS | 3 | |
| 5 | 10589309 | Anchor | P338213005 | C-1290 | SANKO Technology | 3 | |

Unit No. 17
 Drive Wheel Speed Reducer(1)-1/2

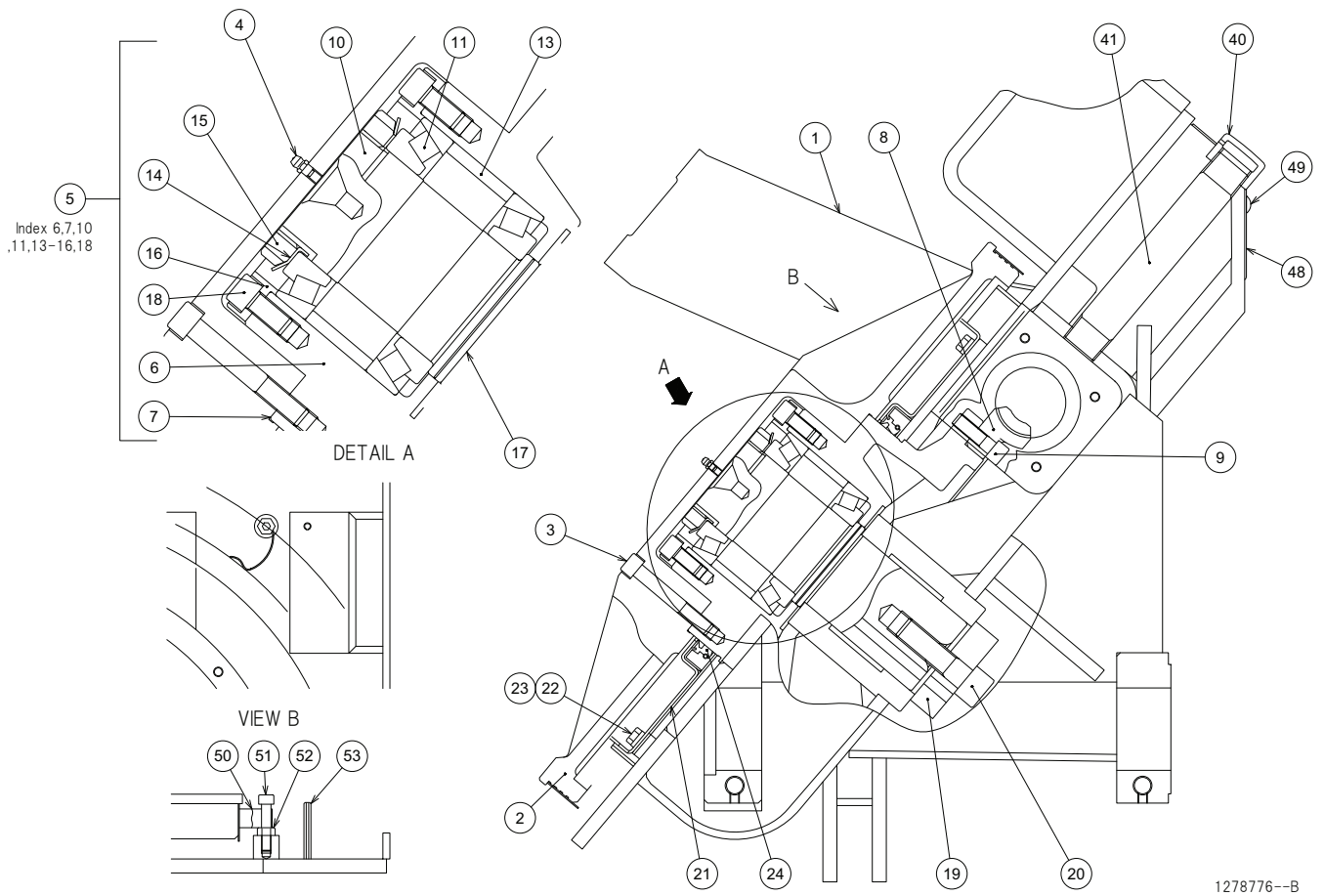

1278776--B

Unit No. 17
Drive Wheel Speed Reducer(1)-2/2

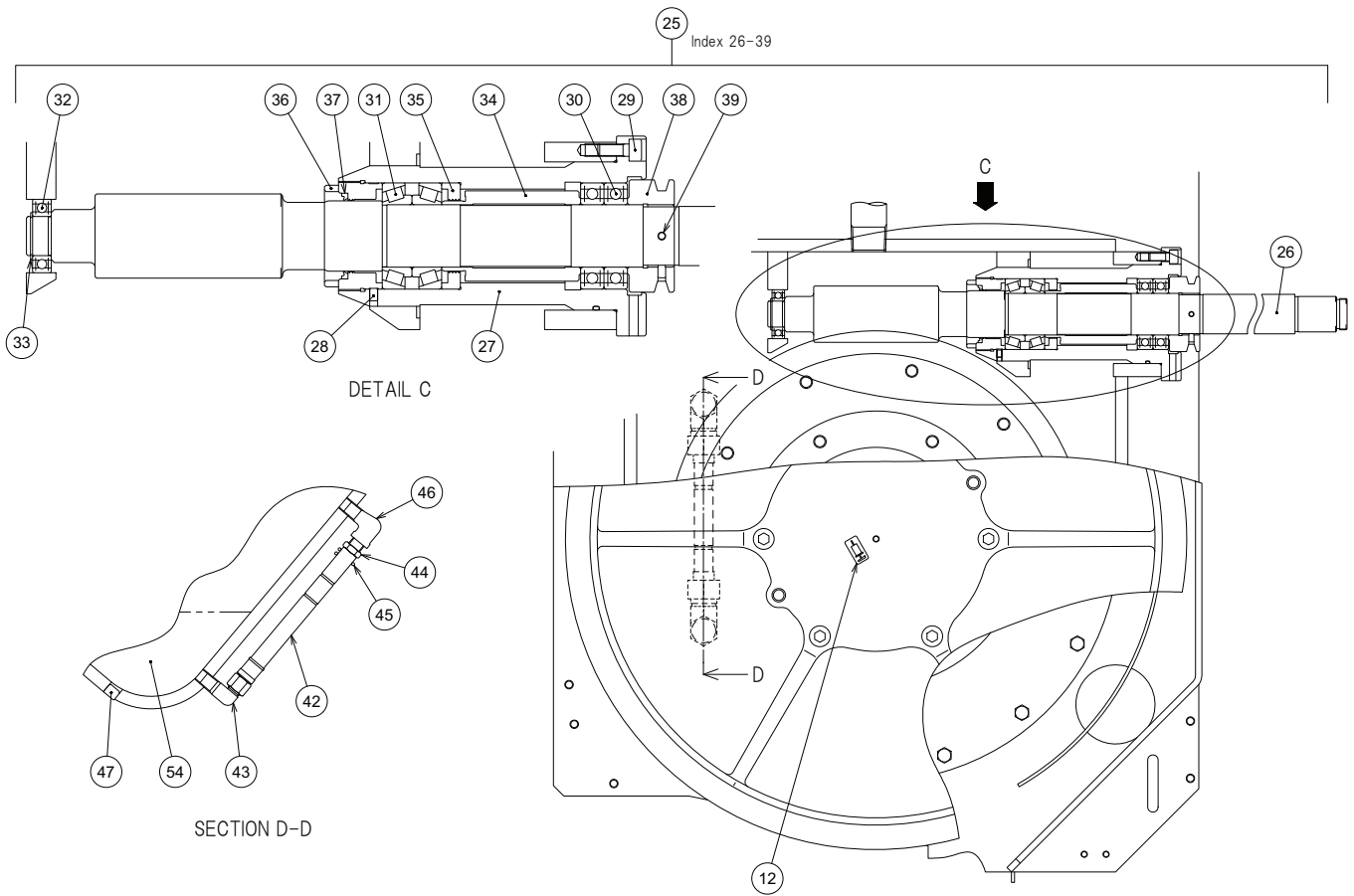

1278776--B

Unit No. 17

Drive Wheel Speed Reducer(1)

| Index | Code | Parts Name | Drawing No. | Type | Maker | Q'ty | Note |
|-------|----------|----------------------|-------------|--|---------------|------|---------|
| 1 | 10301439 | Housing Machine ASSY | RB01773--B | | | 1 | |
| 2 | 10311114 | Drive Wheel | 1230110 A | | | 1 | |
| 3 | 10000830 | Hex Socket Cap Screw | P330250015 | M12X80 | | 6 | |
| 4 | 10419913 | Grease Nipple | P560600002 | A-MT6X1 | JIS | 1 | |
| 5 | 10302093 | Housing ASSY | SBS0126--- | 1230091 D, 1230088, RB01778--A others | | 1 | |
| 6 | 10380342 | Worm Housing | 1230091 D | | | 1 | |
| 7 | 10322525 | Shim | 1230088 | | | 1 | |
| 8 | 10311127 | Worm Wheel | 1230092 B | | | 1 | |
| 9 | 10328331 | Hex Socket Cap Screw | P330250007 | M12X40 | | 10 | |
| 10 | 10301440 | Driving Shaft | RB01778--A | | | 1 | |
| 11 | 10323108 | Taper Roller Bearing | P402010544 | HR30215J | NSK(equality) | 2 | |
| 12 | 10323010 | Name Plate | 0852250 | | | 1 | |
| 13 | 10322521 | Distance Collar | 1230066 B | | | 1 | |
| 14 | 10301442 | Locking Washer | RB0179901- | 75 | | 1 | GB/T858 |
| 15 | 10301443 | Lock Nut | RB0179902- | M75X2 | | 1 | GB/T812 |
| 16 | 10322517 | Adjusting Collar | 1230079 C | | | 1 | |
| 17 | 10322541 | Spacer | 1230068 A | | | 1 | |
| 18 | 10341333 | Hex Socket Cap Screw | P330250004 | M12X25 | | 4 | |
| 19 | 10321917 | Washer | 1230069 D | | | 1 | |

Unit No. 17

Drive Wheel Speed Reducer(1)

| Index | Code | Parts Name | Drawing No. | Type | Maker | Q'ty | Note |
|-------|----------|--------------------------|-------------|-----------------------------|--------------|------|------------------|
| 20 | 10323213 | Hex Socket Cap Screw | P330270009 | M20X70 | | 1 | |
| 21 | 10322542 | Mission Cover | 1230070 E | | | 1 | |
| 22 | 10325826 | Bolt | P330030006 | M8X20 | | 13 | |
| 23 | 10323045 | Gasket | P590608001 | SM-8 | ITO Industry | 13 | |
| 24 | 10301302 | Oil Seal | P590112008 | TB24028019 | NOK | 1 | |
| 25 | 10302094 | Worm Shaft ASSY | SBS0127--- | 1230101 C, 1230099 C others | | 1 | with Index 26-39 |
| 26 | 10311135 | Worm Shaft | 1230101 C | | | 1 | |
| 27 | 10380352 | Bearing Case | 1230099 C | | | 1 | |
| 28 | 10324222 | Socket Set Screw | P330590012 | M5X8(Dimple Type) | JIS | 2 | |
| 29 | 10322202 | Hex Socket Cap Screw | P330230006 | M8X20 | | 4 | |
| 30 | 10324023 | Deep Groove Ball Bearing | P400010545 | 6008VV | NSK & others | 2 | |
| 31 | 10324015 | Taper Roller Bearing | P402010505 | HR32008XJ | NSK & others | 2 | |
| 32 | 10380358 | Deep Groove Ball Bearing | P400010527 | 6005ZZ | NSK & others | 1 | |
| 33 | 10310821 | Locating Snap Ring | P406108046 | STW-25 | OCHIAI | 1 | |
| 34 | 10322407 | Collar | 1230097 | | | 1 | |
| 35 | 10322406 | Collar | 1230096 A | | | 1 | |
| 36 | 10322401 | Screw | 1230095 | | | 1 | |
| 37 | 10380361 | Oil Seal for Bearing | P406134002 | G45X55X4 | NTN | 1 | |
| 38 | 10322421 | Wire Brush Pulley | 1230100 | | | 1 | |

Unit No. 17

Drive Wheel Speed Reducer(1)

| Index | Code | Parts Name | Drawing No. | Type | Maker | Q'ty | Note |
|-------|----------|----------------------|-------------|-------------------|---------------------|------|------|
| 39 | 10324222 | Socket Set Screw | P330590012 | M5X8(Dimple Type) | JIS | 2 | |
| 40 | 10322544 | Cap | 1230085 | | | 1 | |
| 41 | 10322545 | Nipple | 1230086 A | | | 1 | |
| 42 | 10583587 | Level Hose | 1230077 B | | | 1 | |
| 43 | 10301301 | Hose Adapter | P589222238 | 1033-PT1/4-PF1/4 | The Yokohama Rubber | 1 | |
| 44 | 10205212 | Vinyl Hose Connector | 0800087 A | | | 1 | |
| 45 | 10380357 | Hose Band | P381008029 | AK-1016 | SUGITAVALVE | 1 | |
| 46 | 10359921 | Elbow | P580050011 | 1/4(Male-Female) | JIS | 1 | |
| 47 | 10300171 | Plug for Piping | P580208021 | PT-1/4 | | 1 | |
| 48 | 10301441 | Wiring Cover | RB01793--A | | | 1 | |
| 49 | 10340019 | Truss Head Screw | P334130012 | M6X12 | JIS | 2 | |
| 50 | 10310913 | Spring Holder | 0604077 A | | | 1 | |
| 51 | 10323207 | Hex Socket Cap Screw | P330230010 | M8X40 | | 1 | |
| 52 | 10001517 | Nut | P332000064 | M8(Type-1) | JIS | 1 | |
| 53 | 10334628 | Spring Pin | P337030071 | 6X60AW | JIS | 1 | |
| 54 | 10419315 | Gear Oil | QZZ036531 | SP320 5.5LITER | NISSEKI | 1 | |

Unit No. 18
Drive Wheel Speed Reducer(2) <HFA400W>

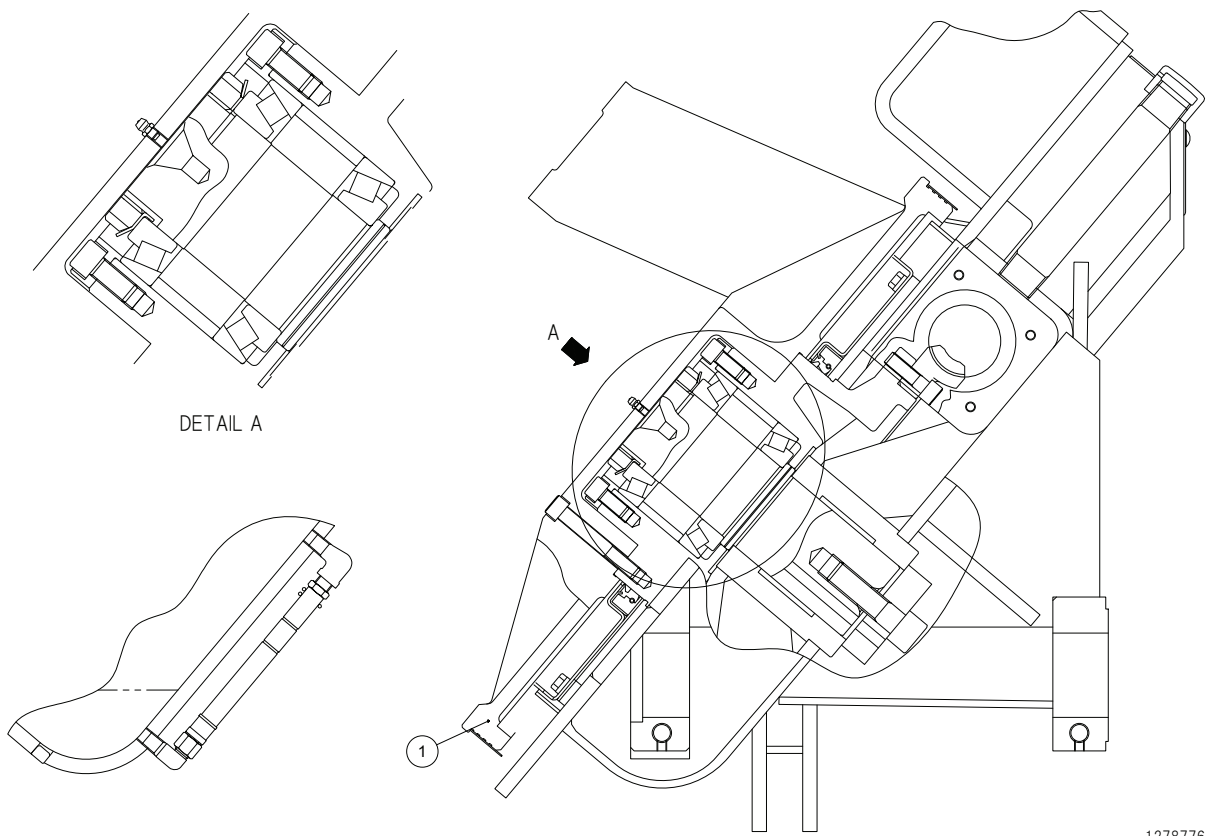

Unit No. 18

Drive Wheel Speed Reducer(2)

| Index | Code | Parts Name | Drawing No. | Type | Maker | Q'ty | Note |
|-------|----------|-------------|-------------|------|-------|------|------|
| 1 | 10322503 | Drive Wheel | 1231724 | | | 1 | |

Unit No. 19
Drive Wheel Speed Reducer(3)-1/2 <Sawhead Cover>

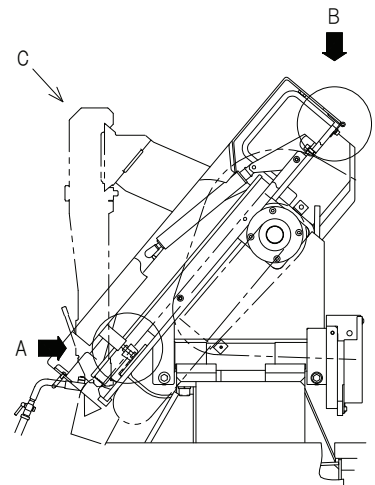
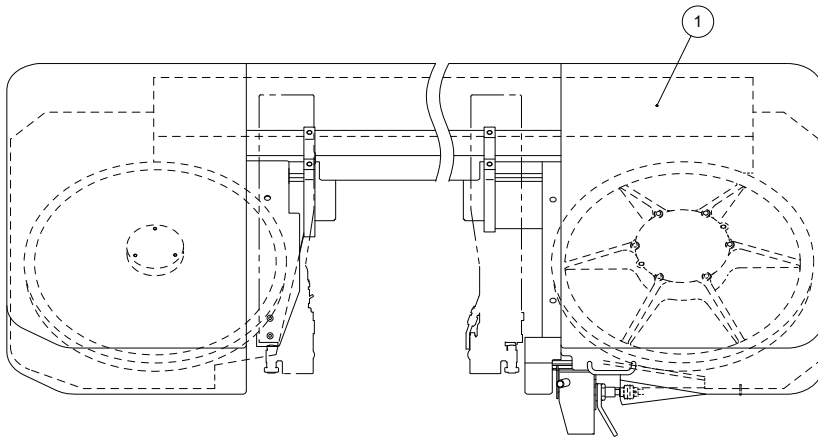
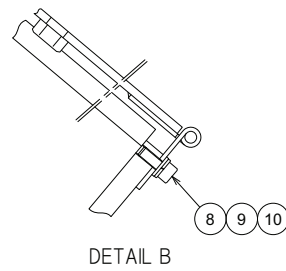
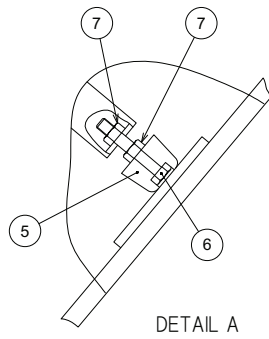

1278777--A

Unit No. 19
 Drive Wheel Speed Reducer(3)-2/2 <Sawhead Cover>

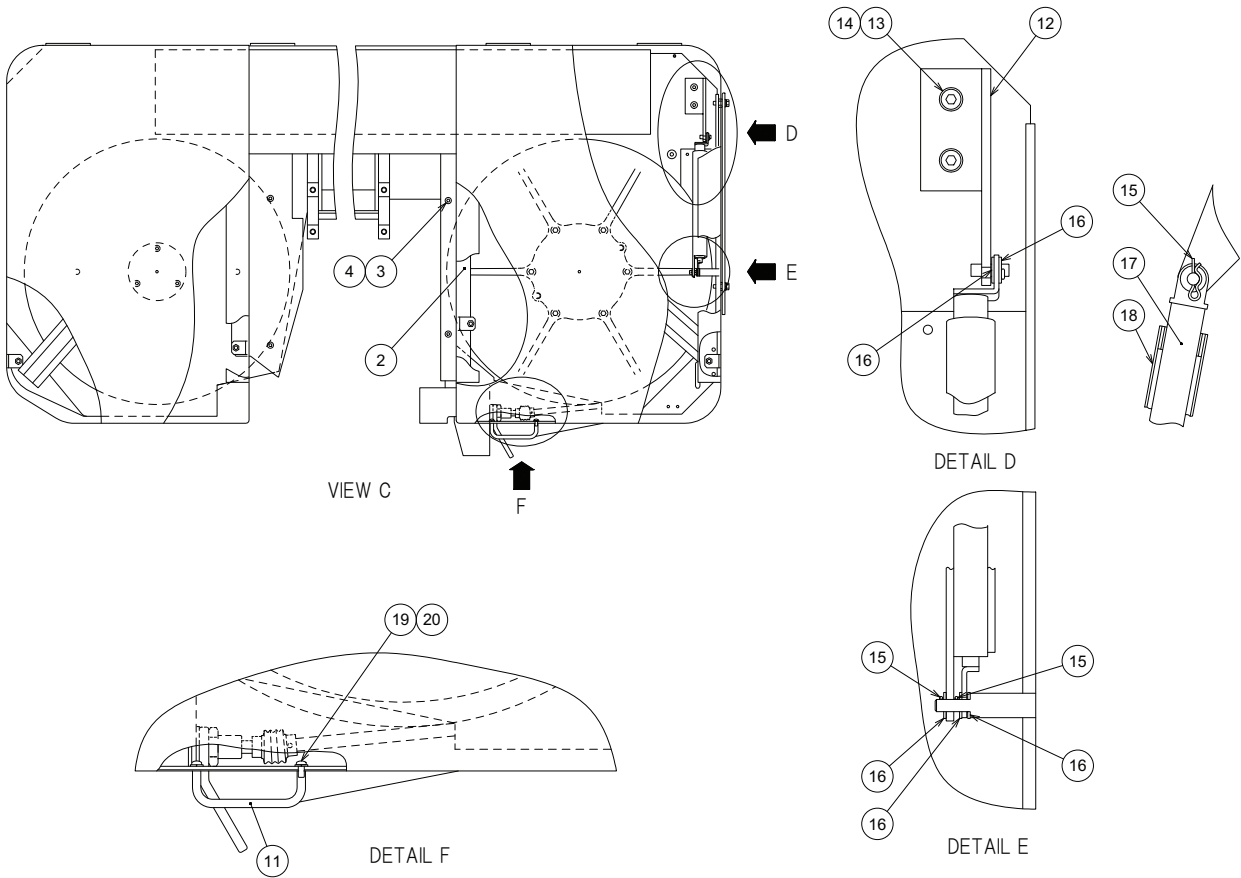

Unit No. 19

Drive Wheel Speed Reducer(3)

| Index | Code | Parts Name | Drawing No. | Type | Maker | Q'ty | Note |
|-------|----------|----------------------|-------------|-------------------|----------|------|------|
| 1 | 10583588 | Wheel Cover | 1230657 H | | | 1 | |
| 2 | 10583589 | Drive Sub Cover | 1230656 B | | | 1 | |
| 3 | 10322202 | Hex Socket Cap Screw | P330230006 | M8X20 | | 2 | |
| 4 | 10321923 | Washer | P336000006 | 8(Normal) | JIS | 2 | |
| 5 | 10583590 | Vibration Isolator | 124469701A | | | 4 | |
| 6 | 10322262 | Bolt | P330030016 | M8X50(All-thread) | MOURI | 4 | |
| 7 | 10589226 | Nut | P332000005 | M8 | JIS | 8 | |
| 8 | 10323204 | Hex Socket Cap Screw | P330220007 | M6X16 | JIS | 8 | |
| 9 | 10321922 | Washer | P336000005 | 6(Normal) | JIS | 8 | |
| 10 | 10310351 | Spring Washer | P336050005 | 6 | JIS | 8 | |
| 11 | 10583591 | Grip | 124469702B | | CHI-HUEI | 1 | |
| 12 | 10583592 | Hinge Bracket | 1238786 C | | | 1 | |
| 13 | 10343103 | Hex Socket Cap Screw | P330230005 | M8X16 | JIS | 2 | |
| 14 | 10001521 | Spring Washer | P336050006 | 8 | JIS | 2 | |
| 15 | 10301285 | Pine Needle Pin | P337078001 | SSP-8(SWB/White) | OCHIAI | 3 | |
| 16 | 10321923 | Washer | P336000006 | 8(Normal) | JIS | 5 | |
| 17 | 10301925 | Gas Spring | 7720524 | | | 1 | |
| 18 | 10380365 | Gas Spring Cover | 1238077 B | | | 1 | |
| 19 | 10583594 | Screw for Grip | 124469731 | | | 2 | |

Unit No. 19

Drive Wheel Speed Reducer(3)

| Index | Code | Parts Name | Drawing No. | Type | Maker | Q'ty | Note |
|-------|----------|---------------|-------------|------|-------|------|------|
| 20 | 10310351 | Spring Washer | P336050005 | 6 | JIS | 2 | |

Unit No. 20
Gearbox(1)-1/2

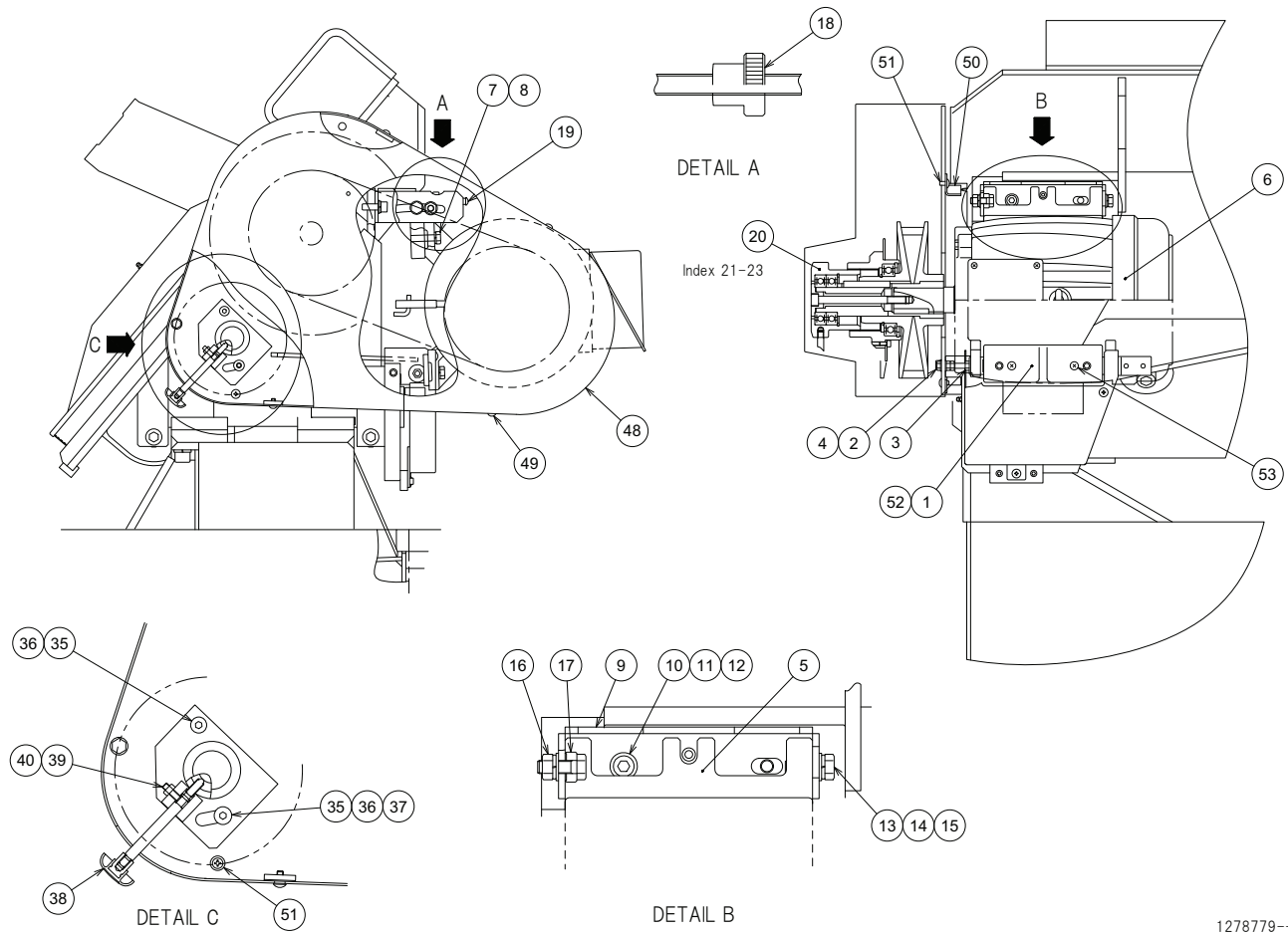

1278779--B

Unit No. 20
Gearbox(1)-2/2

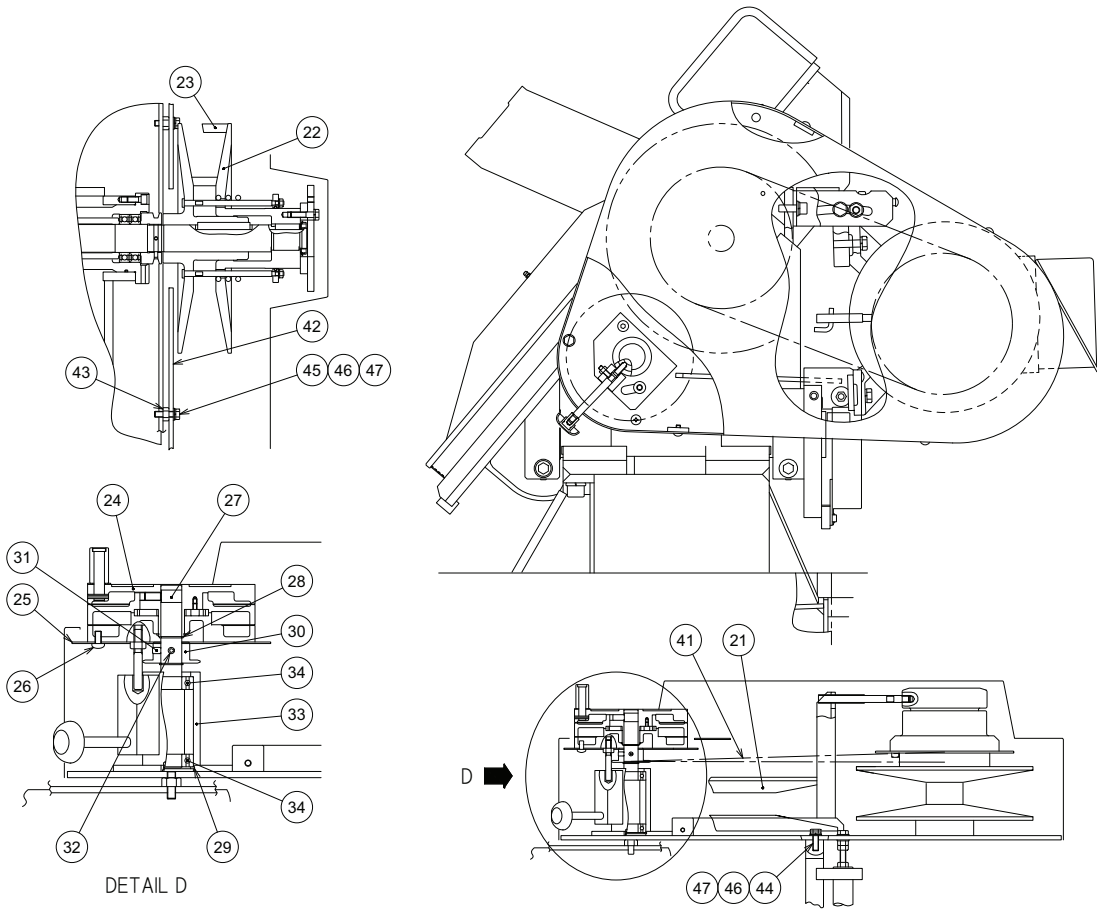

Unit No. 20
Gearbox(1)

| Index | Code | Parts Name | Drawing No. | Type | Maker | Q'ty | Note |
|-------|----------|----------------------|-------------|---------------------|-------|------|---------------------|
| 1 | 10301447 | Hinge Shaft | RB01821--A | | | 1 | |
| 2 | 10325413 | Bolt | P330030018 | M8X60 | | 1 | |
| 3 | 10589226 | Nut | P332000005 | M8 | JIS | 3 | |
| 4 | 10321923 | Washer | P336000006 | 8(Normal) | JIS | 2 | |
| 5 | 10301448 | Motor Base | RB01822--A | | | 1 | |
| 6 | 10301449 | Saw Blade Motor | RB01823--A | Y2-132S-4 B3(5.5kW) | | 1 | Y2-132S-4 B3(5.5Kw) |
| 7 | 10329658 | Bolt | P330040007 | M10X40 | | 4 | |
| 8 | 10001520 | Spring Washer | P336050007 | 10 | JIS | 4 | |
| 9 | 10301450 | Motor Bracket | RB01824--A | | | 1 | |
| 10 | 10322207 | Hex Socket Cap Screw | P330240008 | M10X30 | | 2 | |
| 11 | 10325021 | Washer | P336000007 | 10(Normal) | JIS | 2 | |
| 12 | 10001520 | Spring Washer | P336050007 | 10 | JIS | 2 | |
| 13 | 10325410 | Bolt | P330040005 | M10X30 | | 3 | |
| 14 | 10325021 | Washer | P336000007 | 10(Normal) | JIS | 3 | |
| 15 | 10001520 | Spring Washer | P336050007 | 10 | JIS | 3 | |
| 16 | 10427991 | Nut | P332000006 | M10 | JIS | 1 | |
| 17 | 10325022 | Bite Type Washer | 1230158 A | | | 1 | |
| 18 | 10324331 | Nut (with Knob) | 1230156 | | | 1 | |
| 19 | 10340019 | Truss Head Screw | P334130012 | M6X12 | JIS | 1 | |

Unit No. 20
Gearbox(1)

| Index | Code | Parts Name | Drawing No. | Type | Maker | Q'ty | Note |
|-------|----------|--------------------------|-------------|-------------------|--------------|------|------------------|
| 20 | 10301271 | Variable Speed Drive | 7922539--A | PDS-55-03-N | Miki Pulley | 1 | with Index 21-23 |
| 21 | 10301273 | Drive Pulley | 792253902 | AK-250-G-N | Miki Pulley | 1 | |
| 22 | 10301274 | Driven Pulley | 792253903 | PE-325-B | Miki Pulley | 1 | |
| 23 | 10583598 | Belt | 792253904 | 2322V521 | Miki Pulley | 1 | |
| 24 | 10301275 | Index Handle ASSY | 7922540 A | SD-160-F-N | Miki Pulley | 1 | mm |
| 24 | 10381224 | Index Handle ASSY | 7922541 A | SD-160-G-N | Miki Pulley | 1 | inch |
| 25 | 10380382 | Handle Cover | 1230157 A | | | 1 | |
| 26 | 10322226 | Pan Head Screw | P334100055 | M6X12 | JIS | 3 | |
| 27 | 10419324 | Handle Shaft | 1230147 D | | | 1 | |
| 28 | 10001102 | Locating Snap Ring | P406108043 | STW-20 | OCHIAI | 2 | |
| 29 | 10301293 | Locating Snap Ring | P406108014 | RTW-42 | OCHIAI | 1 | |
| 30 | 10323755 | Sprocket Wheel | 1230150 A | | | 1 | |
| 31 | 10322120 | Socket Set Screw | P330590018 | M6X8(Dimple Type) | JIS | 1 | |
| 32 | 10322110 | Spring Pin | P337030065 | 6X35AW | OHKITA | 1 | |
| 33 | 10380383 | Handle Bracket | 1238114 B | | | 1 | |
| 34 | 10301288 | Deep Groove Ball Bearing | P400010517 | 6004ZZ | NSK & others | 2 | |
| 35 | 10322202 | Hex Socket Cap Screw | P330230006 | M8X20 | | 2 | |
| 36 | 10001521 | Spring Washer | P336050006 | 8 | JIS | 2 | |
| 37 | 10321923 | Washer | P336000006 | 8(Normal) | JIS | 1 | |

Unit No. 20
Gearbox(1)

| Index | Code | Parts Name | Drawing No. | Type | Maker | Q'ty | Note |
|-------|----------|------------------|-------------|----------------|-------|------|------|
| 38 | 10583599 | Lock Knob | 1230149 C | | | 1 | |
| 39 | 10323230 | Socket Set Screw | P330570020 | M6X20(Dog-end) | JIS | 1 | |
| 40 | 10589225 | Nut | P332000004 | M6 | JIS | 1 | |
| 41 | 10310150 | Chain | 1230152 A | | | 1 | |
| 42 | 10301451 | Rear Cover | RB01836--A | | | 1 | |
| 43 | 10356524 | Nut | P332000032 | M10(Type-1) | JIS | 2 | |
| 44 | 10001512 | Bolt | P330030007 | M8X25 | | 1 | |
| 45 | 10325408 | Bolt | P330030008 | M8X30 | | 2 | |
| 46 | 10001521 | Spring Washer | P336050006 | 8 | JIS | 3 | |
| 47 | 10321923 | Washer | P336000006 | 8(Normal) | JIS | 3 | |
| 48 | 10583602 | Cover | 1230629 B | | | 1 | |
| 49 | 10340019 | Truss Head Screw | P334130012 | M6X12 | JIS | 4 | |
| 50 | 10583603 | V-belt Cover | 1230155 | | | 1 | |
| 51 | 10340019 | Truss Head Screw | P334130012 | M6X12 | JIS | 2 | |
| 52 | 10301452 | Spacer | RB01839--C | | | 1 | |
| 53 | 10443238 | Flat Head Screw | P334110029 | M6X16 | JIS | 2 | |

Unit No. 21
Gearbox(2) <Power Source Voltage:230/460V>

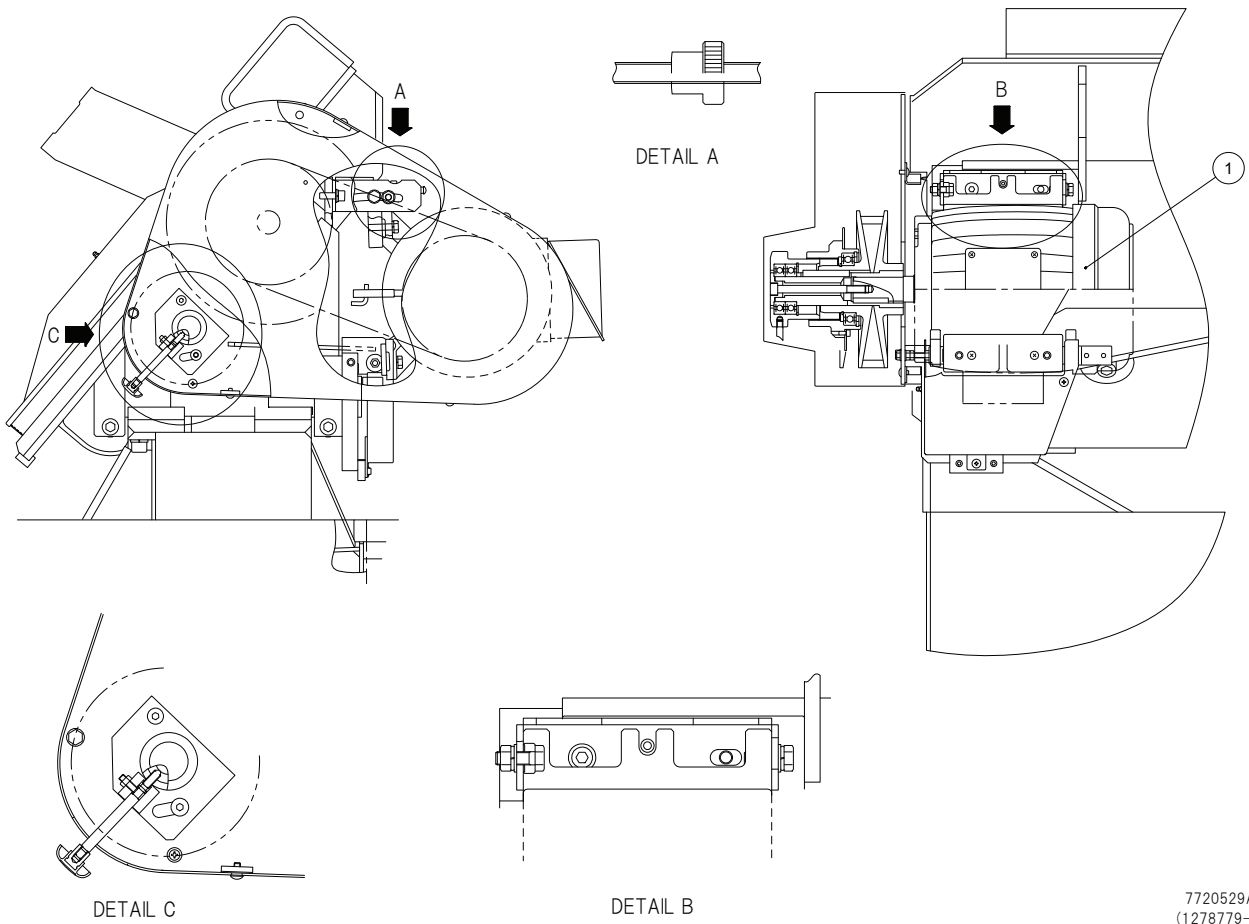

Unit No. 21

Gearbox(2)

| Index | Code | Parts Name | Drawing No. | Type | Maker | Q'ty | Note |
|-------|----------|-----------------|-------------|------|-------|------|------------------|
| 1 | 10583596 | Saw Blade Motor | 7720529 A | | | 1 | 5.5KW 4P230/460V |

Unit No. 22
Gearbox(3) <Power Source Voltage:400V>

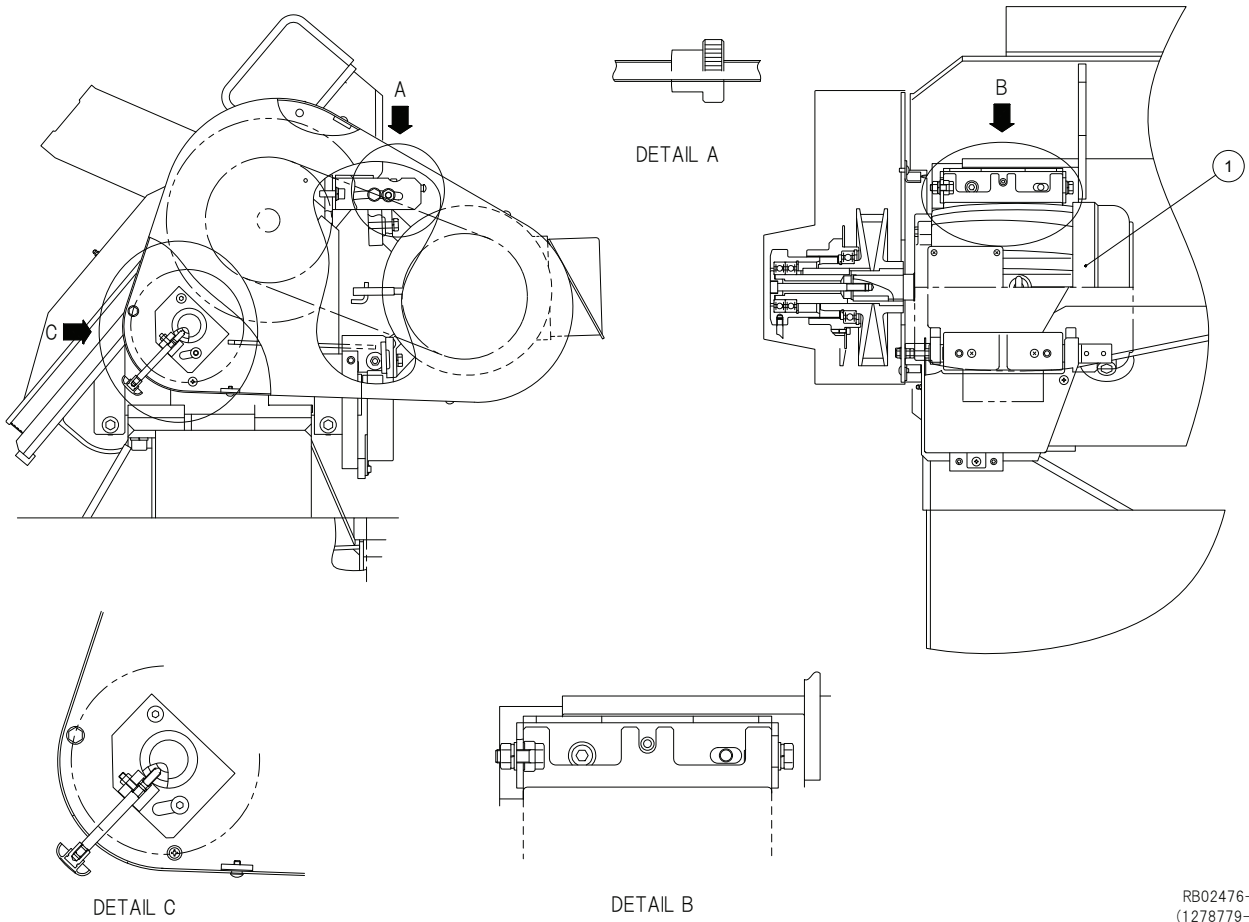

Unit No. 22

Gearbox(3)

| Index | Code | Parts Name | Drawing No. | Type | Maker | Q'ty | Note |
|-------|----------|----------------------|-------------|------|-------|------|--------------|
| 1 | 10301523 | Saw Blade Motor 400V | RB02476--A | | | 1 | 5.5KW 4P400V |

Unit No. 23
 Driven Wheel(1)-1/2

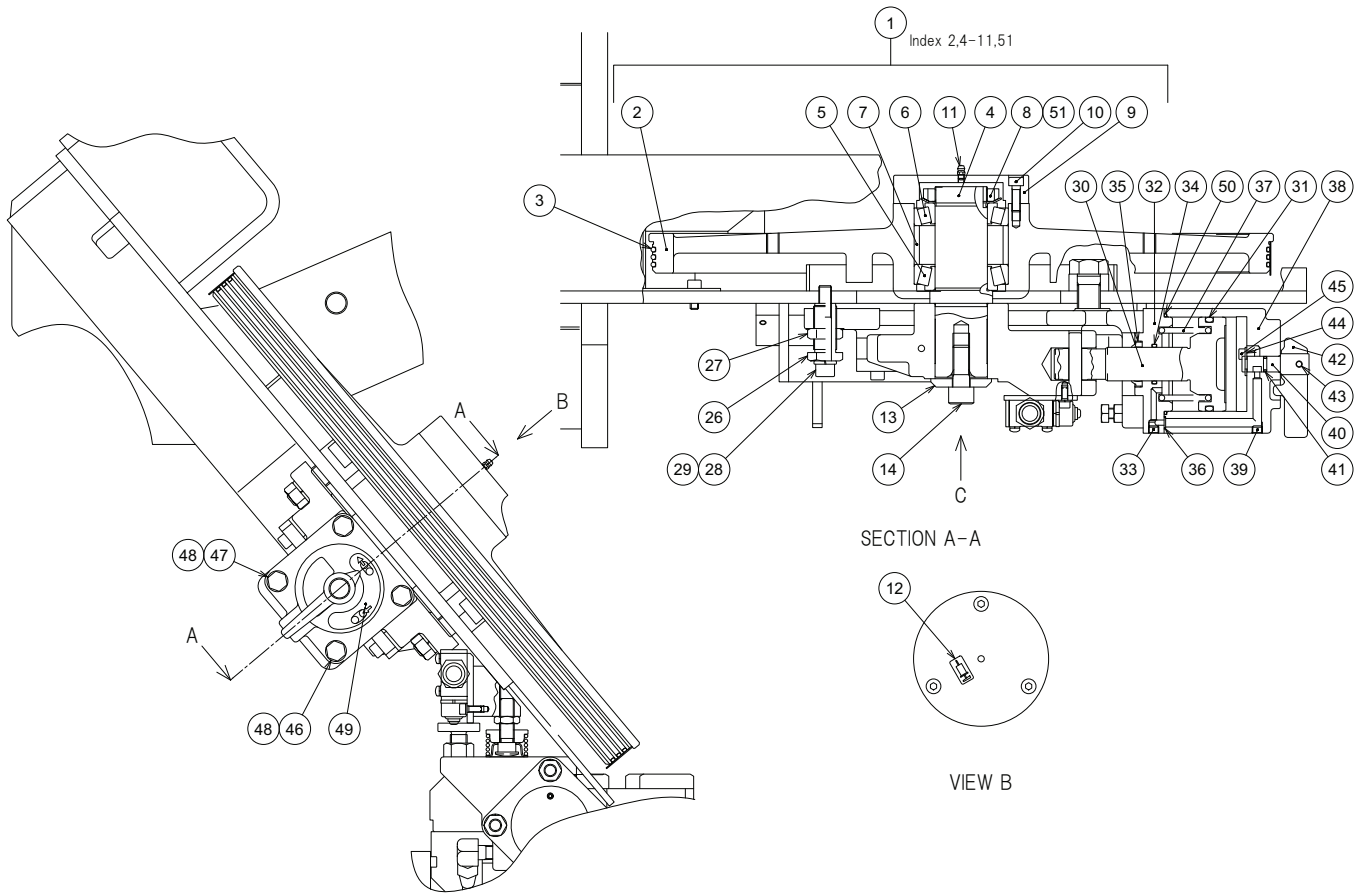

1278780--B

Unit No. 23
Driven Wheel(1)-2/2

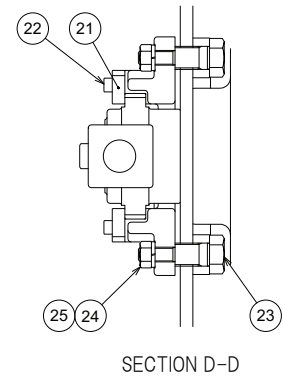
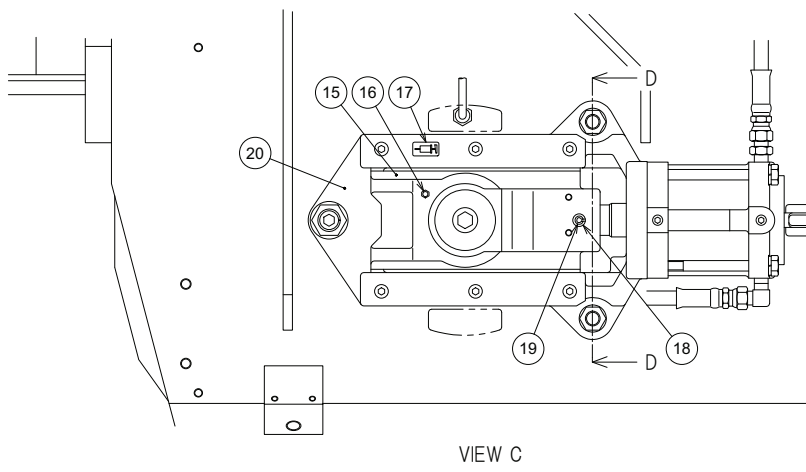

Unit No. 23
Driven Wheel(1)

| Index | Code | Parts Name | Drawing No. | Type | Maker | Q'ty | Note |
|-------|----------|----------------------|-------------|--|---------------|------|----------------------|
| 1 | 10302095 | Driven Wheel ASSY | SBS0128--- | 1238159 A, RB01843--A, 1260155 B others | | 1 | with Index 2,4-11,51 |
| 2 | 10583604 | Idle Wheel | 1238159 A | | | 1 | |
| 3 | 10311214 | Polyurethane Rope | 0636547 C | D4X1730L | | 3 | |
| 4 | 10301453 | Third Shaft | RB01843--A | | | 1 | |
| 5 | 10301292 | Taper Roller Bearing | P402010538 | HR32210J | NSK(equality) | 1 | |
| 6 | 10301291 | Taper Roller Bearing | P402010537 | HR30210J | NSK(equality) | 1 | |
| 7 | 10378109 | Bearing Collar | 1238160 A | | | 1 | |
| 8 | 10301445 | Lock Nut | RB0179904- | M50X1.5 | | 1 | GB/T812 |
| 9 | 10378110 | Bearing Cap | 1260155 B | | | 1 | |
| 10 | 10322202 | Hex Socket Cap Screw | P330230006 | M8X20 | | 3 | |
| 11 | 10419913 | Grease Nipple | P560600002 | A-MT6X1 | JIS | 1 | |
| 12 | 10323010 | Name Plate | 0852250 | | | 1 | |
| 13 | 10311923 | Washer | 0601903 A | | | 1 | |
| 14 | 10323211 | Hex Socket Cap Screw | P330260032 | M16X40 | | 1 | |
| 15 | 10418961 | Slide Piece | 1230182 B | | | 1 | |
| 16 | 10419913 | Grease Nipple | P560600002 | A-MT6X1 | JIS | 1 | |
| 17 | 10323010 | Name Plate | 0852250 | | | 1 | |
| 18 | 10326005 | Spring Pin | P337038006 | SPP-12X60 | OCHIAI | 1 | |
| 19 | 10326004 | Spring Pin | P337030086 | 8X60AW | OHKITA | 1 | |

Unit No. 23
Driven Wheel(1)

| Index | Code | Parts Name | Drawing No. | Type | Maker | Q'ty | Note |
|-------|----------|-------------------------|-------------|--------|-------|------|------|
| 20 | 10418962 | Tension Body | 1230183 F | | | 1 | |
| 21 | 10325821 | Guide Plate | 1230204 B | | | 2 | |
| 22 | 10330101 | Hex Socket Cap Screw | P330230008 | M8X30 | | 6 | |
| 23 | 10325839 | Reamer Bolt M22 | 1230184 B | | | 2 | |
| 24 | 10000826 | Nut | P332000008 | M14 | JIS | 2 | |
| 25 | 10000825 | Spring Washer | P336050009 | 14 | JIS | 2 | |
| 26 | 10311928 | Adjust Bolt | 0601892 A | | | 1 | |
| 27 | 10389578 | Adjusting Nut | 0800113 A | | | 1 | |
| 28 | 10332952 | Hex Socket Cap Screw | P330250014 | M12X75 | MOURI | 1 | |
| 29 | 10000829 | Spring Washer | P336050008 | 12 | JIS | 1 | |
| 30 | 10325842 | Piston | 1230185 A | | | 1 | |
| 31 | 10316808 | O Ring | P590000064 | P80 | | 1 | |
| 32 | 10325968 | Cylinder Cap | 1230186 B | | | 1 | |
| 33 | 10380409 | Plug for Piping | P580208022 | PT-1/8 | | 1 | |
| 34 | 10317827 | O Ring | P590000033 | P32 | | 1 | |
| 35 | 10326120 | Wiper Ring | P590312005 | DKI-32 | NOK | 1 | |
| 36 | 10314519 | O Ring | P590000007 | P9 | | 1 | |
| 37 | 10301148 | Tension Cylinder Spring | 1230191 A | | | 1 | |
| 38 | 10325835 | Cylinder | 1230187 B | | | 1 | |

Unit No. 23
Driven Wheel(1)

| Index | Code | Parts Name | Drawing No. | Type | Maker | Q'ty | Note |
|-------|----------|----------------------|-------------|----------------|-------|------|---------|
| 39 | 10380409 | Plug for Piping | P580208022 | PT-1/8 | | 1 | |
| 40 | 10312050 | Rotary Valve | 1230188 B | | | 1 | |
| 41 | 10206605 | O Ring | P590000010 | P11 | | 1 | |
| 42 | 10312035 | Valve Lever | 1230189 A | | | 1 | |
| 43 | 10326108 | Socket Set Screw | P330570016 | M6X10(Dog-end) | JIS | 1 | |
| 44 | 10312046 | Stopper Plate | 1230190 | | | 1 | |
| 45 | 10312831 | Hex Socket Cap Screw | P330220006 | M6X15 | | 1 | |
| 46 | 10325832 | Bolt | P330040029 | M10X110 | | 2 | |
| 47 | 10325833 | Bolt | P330040040 | M10X130 | MOURI | 2 | |
| 48 | 10001520 | Spring Washer | P336050007 | 10 | JIS | 4 | |
| 49 | 10325860 | Name Plate | 1230192 B | | | 1 | |
| 50 | 10204805 | O Ring | P590010014 | G90 | | 1 | |
| 51 | 10301444 | Locking Washer | RB0179903- | 50 | | 1 | GB/T858 |

Unit No. 24
Driven Wheel(2) <HFA400W>

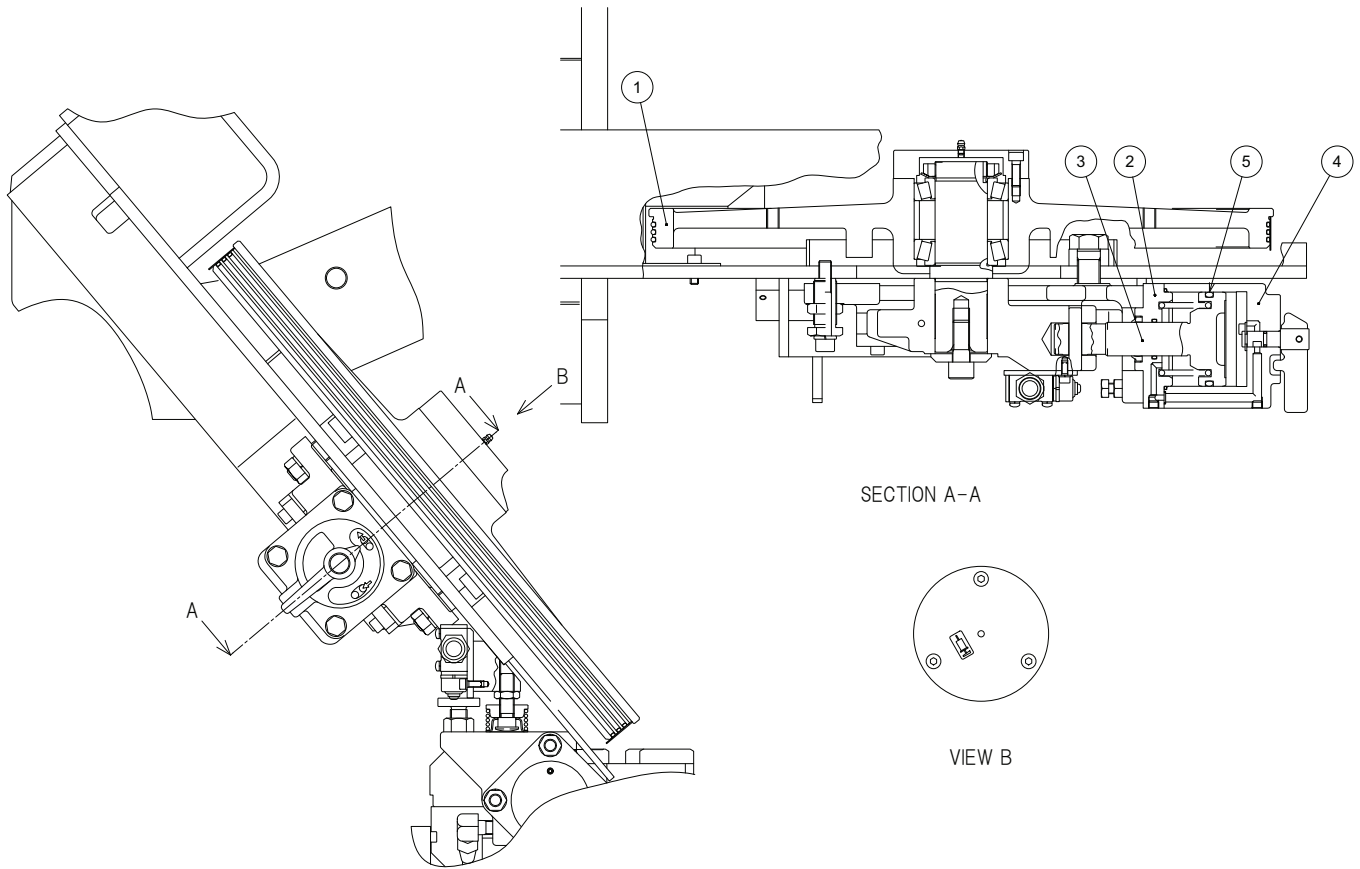

Unit No. 24
Driven Wheel(2)

| Index | Code | Parts Name | Drawing No. | Type | Maker | Q'ty | Note |
|-------|----------|--------------|-------------|------|-------|------|------|
| 1 | 10583605 | Idle Wheel | 1286526 A | | | 1 | |
| 2 | 10301169 | Cylinder Cap | 1231735 A | | | 1 | |
| 3 | 10388120 | Piston | 1231736 A | | | 1 | |
| 4 | 10325851 | Cylinder | 1231737 | | | 1 | |
| 5 | 10326106 | O Ring | P590000065 | P85 | | 1 | |

Unit No. 25
Driven Wheel(3) <Lower Limit Stopper>

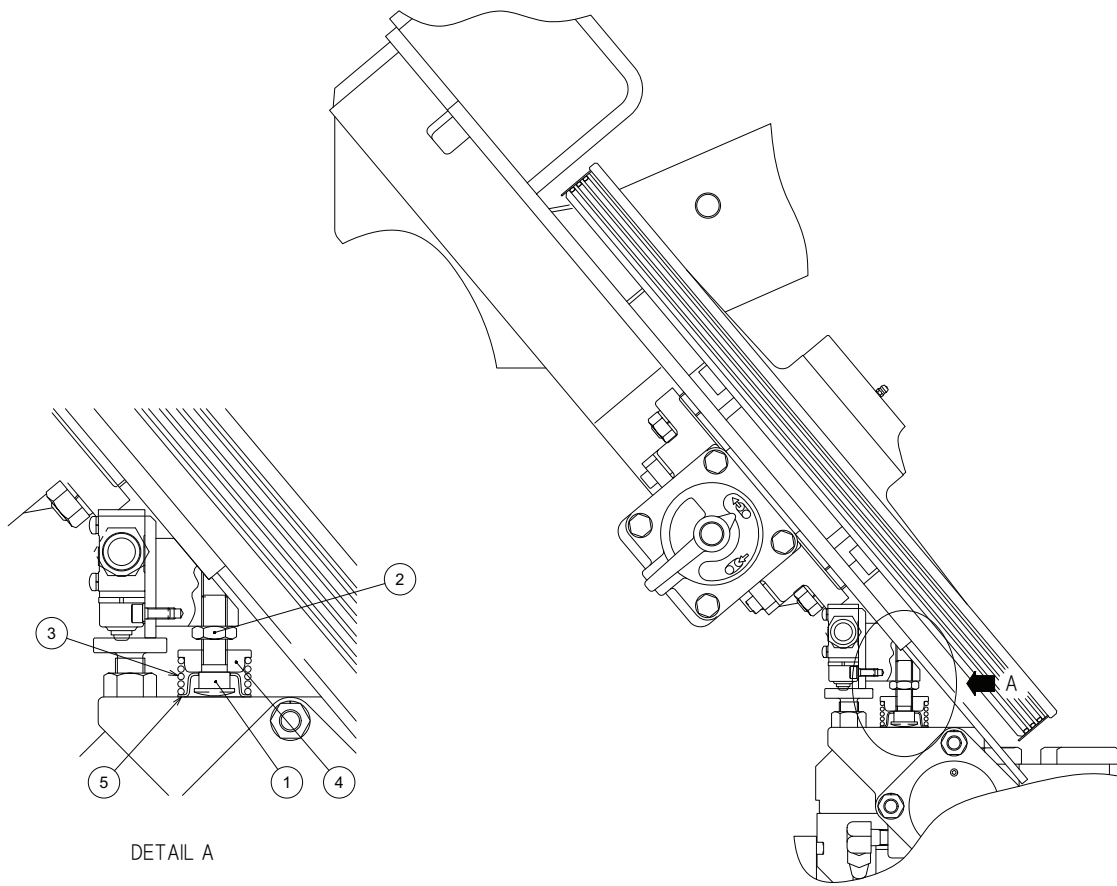

1278781---
(1278780--B)

Unit No. 25
Driven Wheel(3)

| Index | Code | Parts Name | Drawing No. | Type | Maker | Q'ty | Note |
|-------|----------|----------------|-------------|-------------|-------|------|------|
| 1 | 10583607 | Stopper Bolt | 1230631 B | | | 1 | |
| 2 | 10323102 | Nut | P332000107 | M14(Type-3) | JIS | 1 | |
| 3 | 10325940 | Spring | 7023480 | | | 1 | |
| 4 | 10325945 | Stopper Nut | 7023481 | | | 1 | |
| 5 | 10325947 | Spring Support | 7023482 | | | 1 | |

Unit No. 26
Driven Wheel(4)-1/2 <Limit Switch>

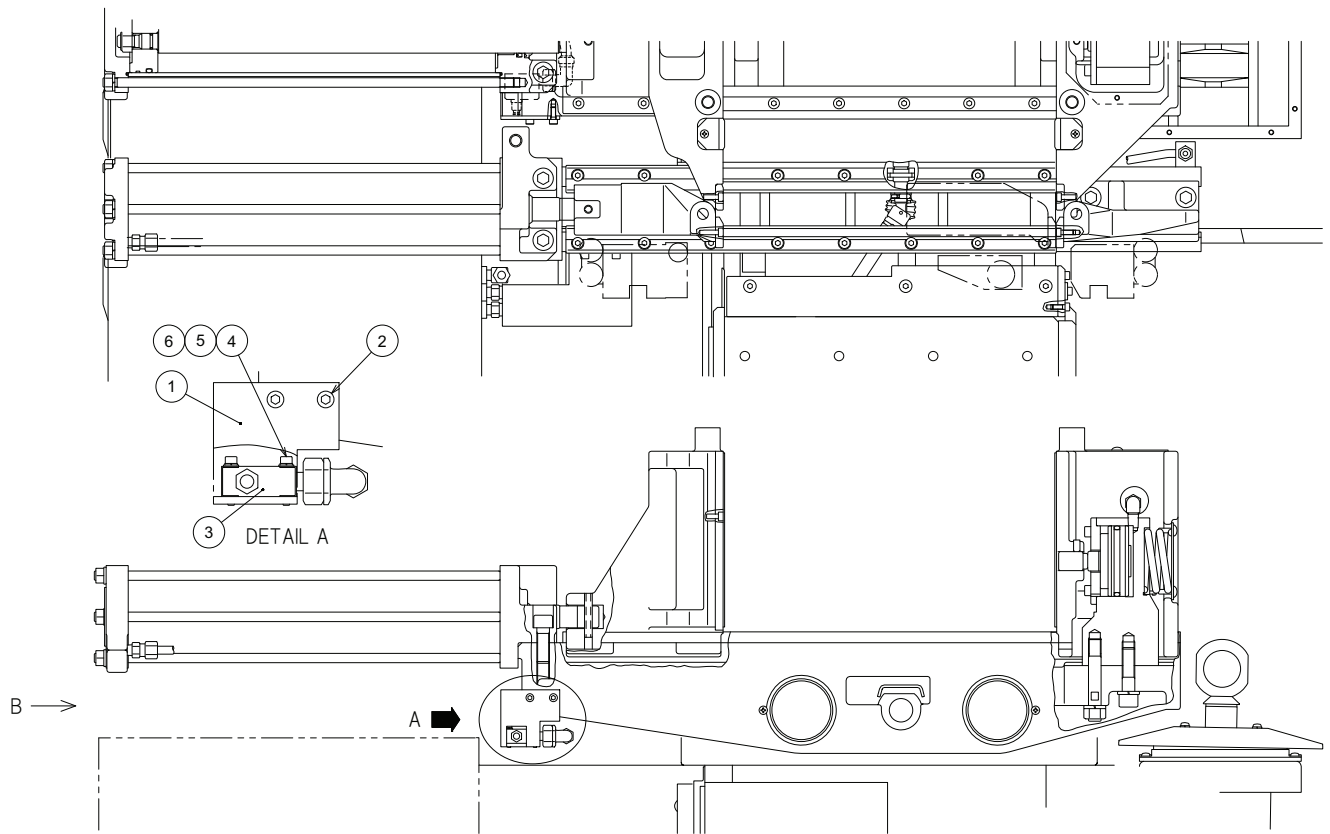

1278802---
(1278801--A)

Unit No. 26
Driven Wheel(4)-2/2 <Limit Switch>

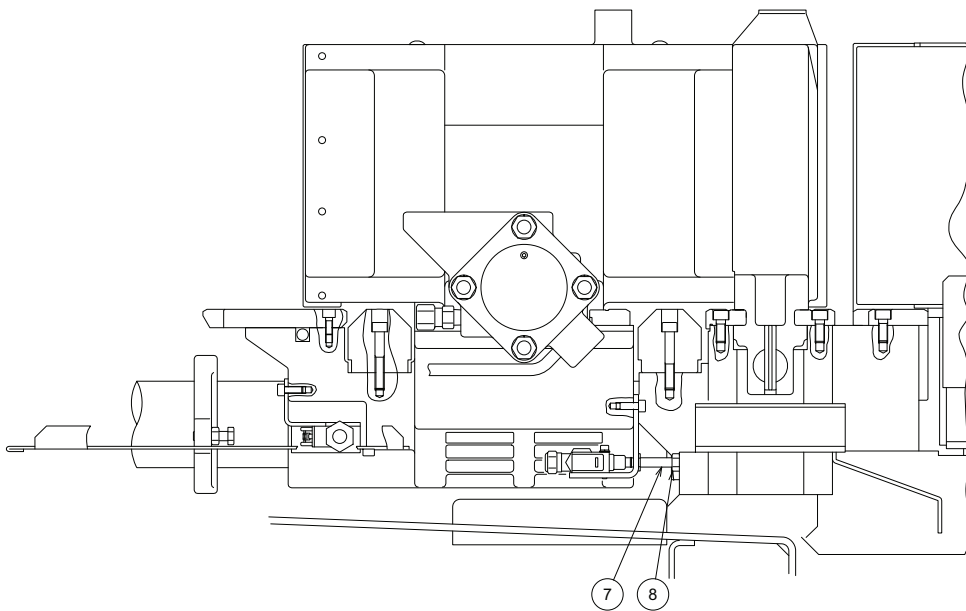

VIEW B

1278802---
(1278801--A)

Unit No. 26
Driven Wheel(4)

| Index | Code | Parts Name | Drawing No. | Type | Maker | Q'ty | Note |
|-------|----------|----------------------|-------------|-------------------|----------|------|------|
| 1 | 10419768 | LS Bracket | 1238495 B | | | 1 | |
| 2 | 10323204 | Hex Socket Cap Screw | P330220007 | M6X16 | JIS | 2 | |
| 3 | 10318839 | Limit Switch | P828013017 | SL1-S155 | YAMATAKE | 1 | |
| 4 | 10363419 | Hex Socket Cap Screw | P330200022 | M4X25 | | 2 | |
| 5 | 10337110 | Washer | P336000003 | 4(Small Round) | JIS | 2 | |
| 6 | 10318527 | Spring Washer | P336050003 | 4 | JIS | 2 | |
| 7 | 10382724 | Bolt | P330030014 | M8X45(All-thread) | MOURI | 1 | |
| 8 | 10589226 | Nut | P332000005 | M8 | JIS | 1 | |

Unit No. 27
Driven Wheel(5) <Blade Guard>

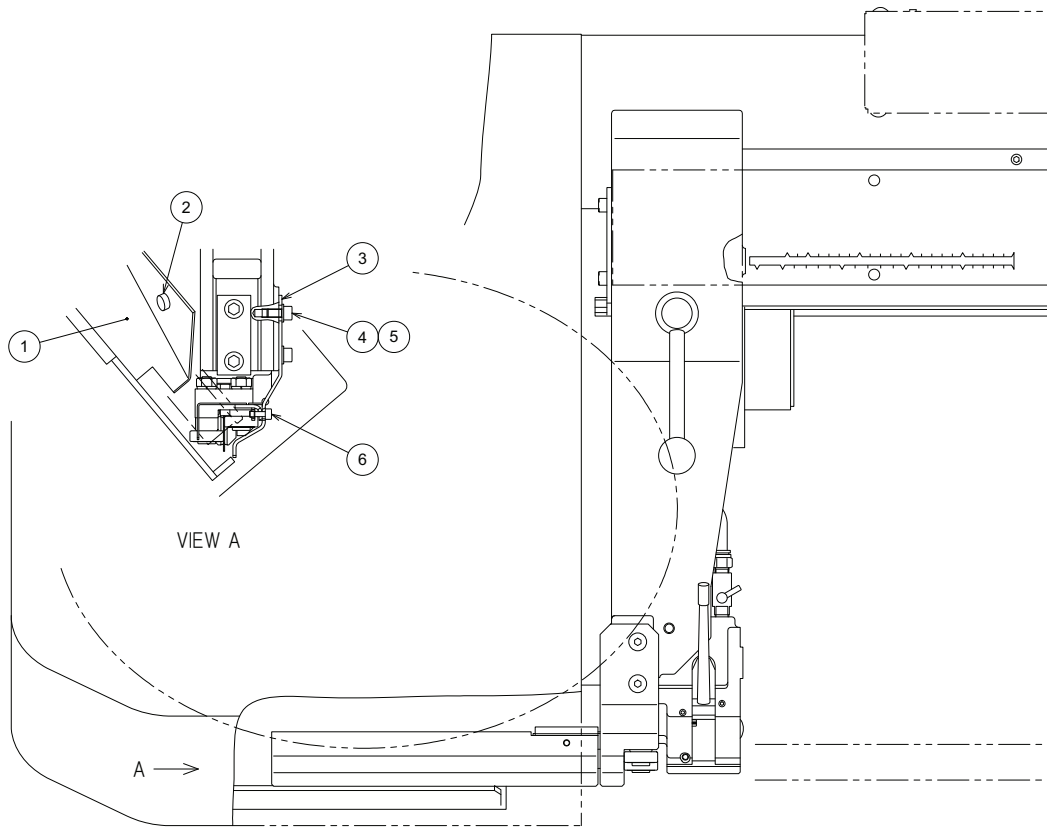

1278782--A

Unit No. 27
Driven Wheel(5)

| Index | Code | Parts Name | Drawing No. | Type | Maker | Q'ty | Note |
|-------|----------|----------------------|-------------|-----------|-------|------|------|
| 1 | 10583609 | Driven Support Cover | 1230658 B | | | 1 | |
| 2 | 10322202 | Hex Socket Cap Screw | P330230006 | M8X20 | | 2 | |
| 3 | 10583610 | Blade Guard | 1230639 | | | 1 | |
| 4 | 10343103 | Hex Socket Cap Screw | P330230005 | M8X16 | JIS | 2 | |
| 5 | 10321923 | Washer | P336000006 | 8(Normal) | JIS | 2 | |
| 6 | 10322615 | Hex Socket Cap Screw | 1200256 A | M6X16 | | 1 | |

Unit No. 28
Saw Blade Guide(1)-1/3

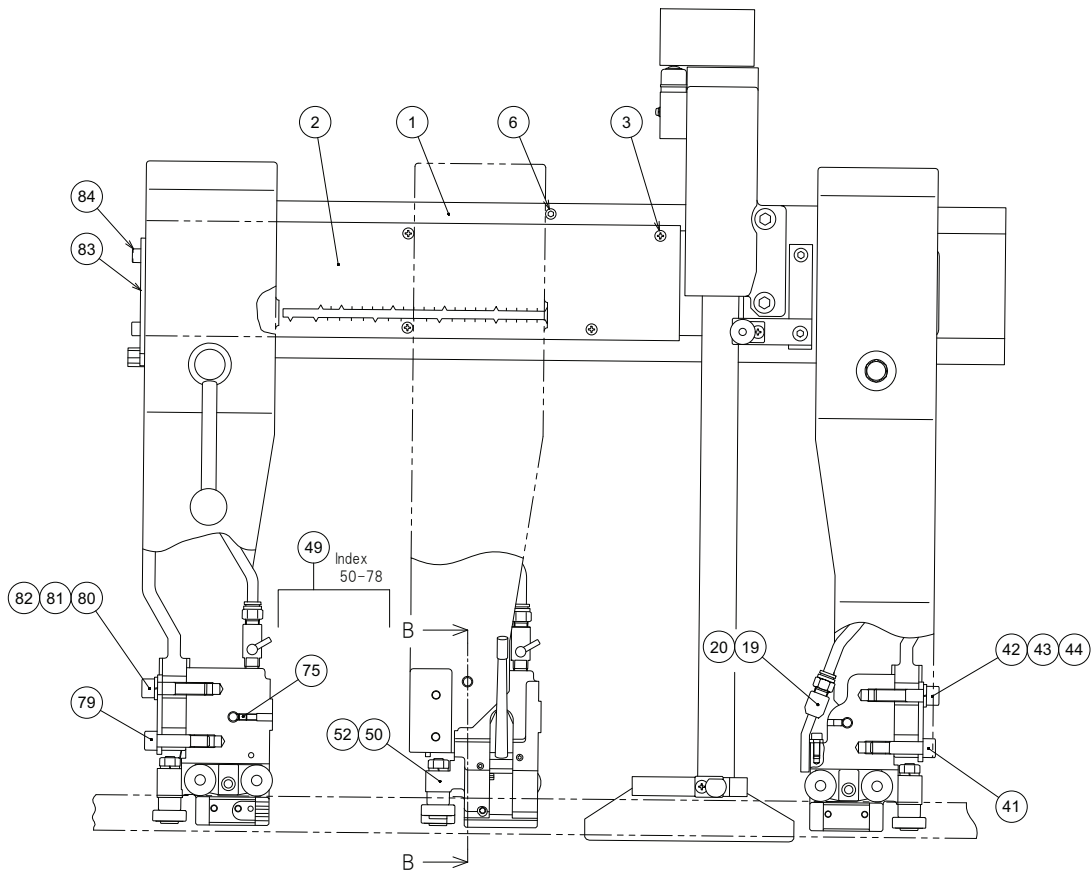

1278784--A

Unit No. 28
Saw Blade Guide(1)-2/3

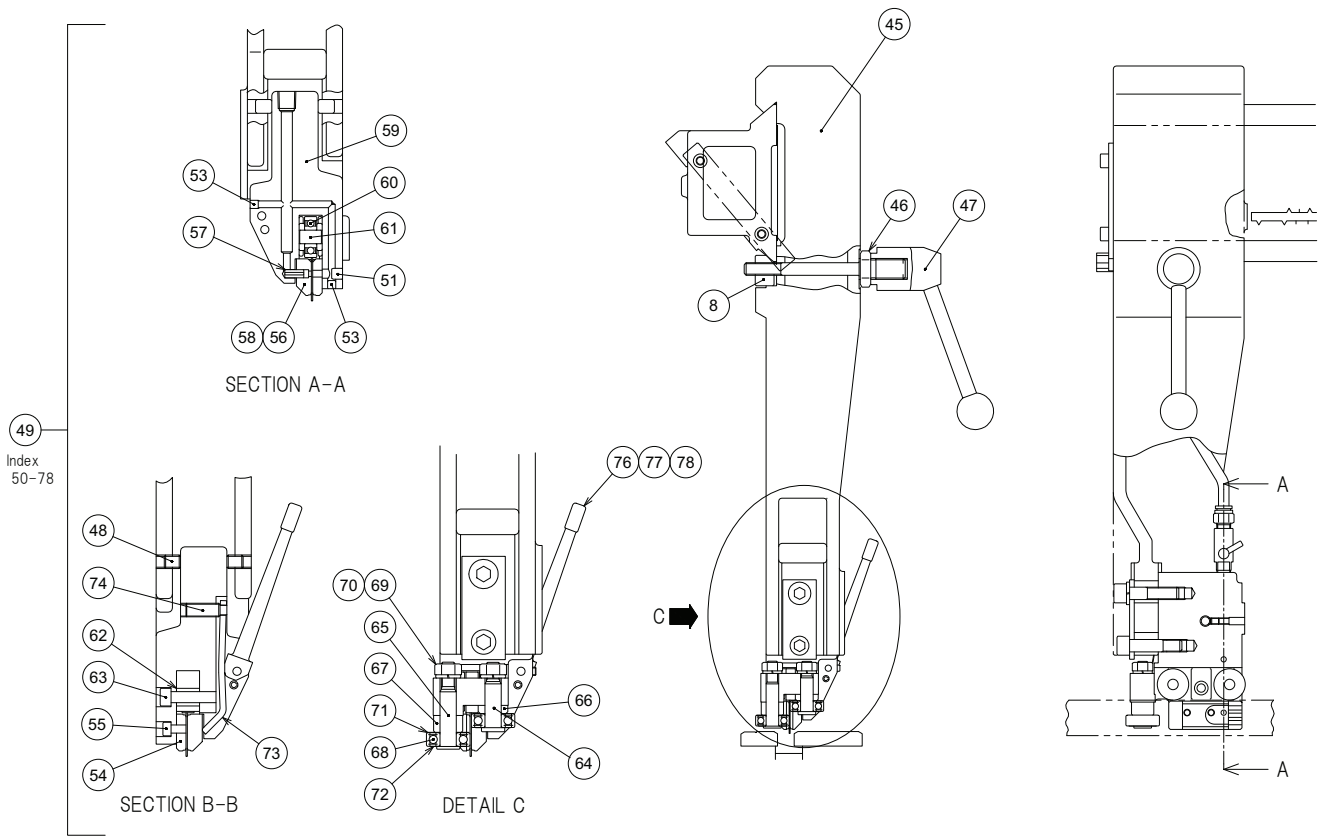

1278784--A

Unit No. 28
Saw Blade Guide(1)-3/3

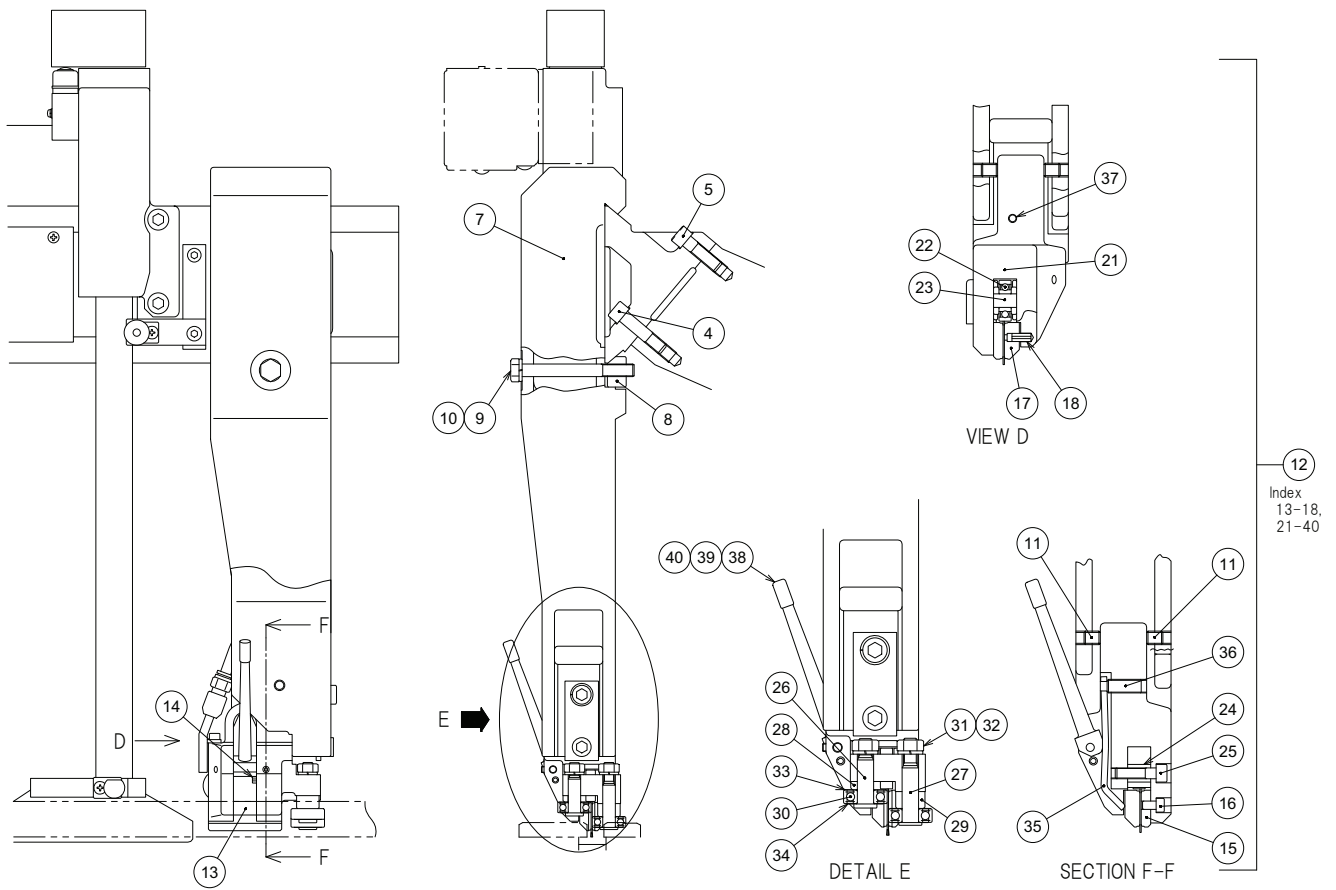

12
Index
13-18,
21-40

1278784--A

Unit No. 28

Saw Blade Guide(1)

| Index | Code | Parts Name | Drawing No. | Type | Maker | Q'ty | Note |
|-------|----------|----------------------|-------------|--------------------------------------|-------|------|------------------------|
| 1 | 10583611 | Guide Bar | 1230651 B | | | 1 | |
| 2 | 10301170 | Support Plate | 1238193 C | | | 1 | |
| 3 | 10322226 | Pan Head Screw | P334100055 | M6X12 | JIS | 6 | |
| 4 | 10583617 | Reamer Bolt M12 | 1230243 B | (M12X50) | | 2 | L(1)/R(1) |
| 5 | 10328331 | Hex Socket Cap Screw | P330250007 | M12X40 | | 2 | L(1)/R(1) |
| 6 | 10312831 | Hex Socket Cap Screw | P330220006 | M6X15 | | 1 | |
| 7 | 10583612 | Guide Bracket R | 1238216 A | | | 1 | R(Qty)' |
| 8 | 10378136 | Slide Chip | 1238186 A | | | 2 | L(1)/R(1) |
| 9 | 10325412 | Bolt | P330050022 | M12X100 | | 1 | R(Qty)' |
| 10 | 10000829 | Spring Washer | P336050008 | 12 | JIS | 1 | R(Qty)' |
| 11 | 10322126 | Socket Set Screw | P330550049 | M10X12(Flat Type) | JIS | 2 | R(Qty)' |
| 12 | 10302096 | Insert Holder R ASSY | SBS0664--- | 1238202, 1230250 B, 1230251 B others | | 1 | with Index 13-18,21-40 |
| 13 | 10386032 | Insert Holder R | 1238202 | | | 1 | R(Qty)' |
| 14 | 10328305 | Spring Pin | P337030062 | 6X28AW | JIS | 2 | L(1)/R(1) |
| 15 | 10312347 | Fixed Insert R | 1230250 B | | | 1 | R(Qty)' |
| 16 | 10589206 | Hex Socket Cap Screw | P330220003 | M6X10 | | 2 | R(Qty)' |
| 17 | 10312349 | Movable Insert R | 1230251 B | | | 1 | R(Qty)' |
| 18 | 10328304 | Spring Pin | P337030055 | 6X14AW | JIS | 1 | R(Qty)' |
| 19 | 10312539 | Nozzle | 1230259 D | | | 1 | R(Qty)' |

Unit No. 28

Saw Blade Guide(1)

| Index | Code | Parts Name | Drawing No. | Type | Maker | Q'ty | Note |
|-------|----------|--------------------------|-------------|-----------------|-------|------|---------|
| 20 | 10312831 | Hex Socket Cap Screw | P330220006 | M6X15 | | 1 | R(Qty)' |
| 21 | 10418979 | Backup Roller Holder | 1230254 A | | | 1 | R(Qty)' |
| 22 | 10300129 | Deep Groove Ball Bearing | 7922885--- | 6200LLU/LP03QT | NTN | 2 | R(Qty)' |
| 23 | 10312852 | Roller Pin | 0637054 | | | 2 | R(Qty)' |
| 24 | 10385735 | Sleeve | 1230255 A | | | 1 | R(Qty)' |
| 25 | 10330101 | Hex Socket Cap Screw | P330230008 | M8X30 | | 1 | R(Qty)' |
| 26 | 10383828 | Bearing Shaft 1 | 1109933 | | | 1 | R(Qty)' |
| 27 | 10383829 | Bearing Shaft 2 | 1109934 | | | 1 | R(Qty)' |
| 28 | 10383830 | Bearing Collar 1 | 1109935 | | | 1 | R(Qty)' |
| 29 | 10386035 | Bearing Collar 2 | 1238199 | | | 1 | R(Qty)' |
| 30 | 10300130 | Ball Bearing | 7922888--- | 6201LLU/LP03QT | | 2 | R(Qty)' |
| 31 | 10427991 | Nut | P332000006 | M10 | JIS | 2 | R(Qty)' |
| 32 | 10001520 | Spring Washer | P336050007 | 10 | JIS | 2 | R(Qty)' |
| 33 | 10383832 | Shim 1 | 1109937 | | | 2 | R(Qty)' |
| 34 | 10578740 | Shim 2 | 1109936 A | | | 2 | R(Qty)' |
| 35 | 10301149 | Plate (for Spring) | 1230256--B | | | 1 | R(Qty)' |
| 36 | 10324226 | Socket Set Screw | P330570035 | M10X30(Dog-end) | JIS | 1 | R(Qty)' |
| 37 | 10329309 | Socket Set Screw | P330550025 | M6X8(Flat Type) | JIS | 1 | R(Qty)' |
| 38 | 10001840 | Cam Lever | 1230257 C | | | 1 | R(Qty)' |

Unit No. 28

Saw Blade Guide(1)

| Index | Code | Parts Name | Drawing No. | Type | Maker | Q'ty | Note |
|-------|----------|--------------------------|-------------|--------------------------------------|-------|------|------------------|
| 39 | 10380430 | Parallel Pin | P337020155 | B-6X50 | JIS | 1 | R(Qty)' |
| 40 | 10322120 | Socket Set Screw | P330590018 | M6X8(Dimple Type) | JIS | 1 | R(Qty)' |
| 41 | 10583617 | Reamer Bolt M12 | 1230243 B | (M12X50) | | 1 | R(Qty)' |
| 42 | 10328337 | Hex Socket Cap Screw | P330250009 | M12X50 | | 1 | R(Qty)' |
| 43 | 10000829 | Spring Washer | P336050008 | 12 | JIS | 1 | R(Qty)' |
| 44 | 10380421 | Washer | 1238187 | | | 1 | R(Qty)' |
| 45 | 10583614 | Guide Bracket L | 1238217 D | | | 1 | L(Qty)' |
| 46 | 10378135 | Stud Bolt | 1238181 | | | 1 | L(Qty)' |
| 47 | 10583615 | Lever | 124469704A | TPH40-M20-120 | TOBOX | 1 | L(Qty)' |
| 48 | 10322126 | Socket Set Screw | P330550049 | M10X12(Flat Type) | JIS | 2 | L(Qty)' |
| 49 | 10302097 | Insert Holder L ASSY | SBS0129--- | 1238203, 1230252 B, 1230253 B others | | 1 | with Index 50-78 |
| 50 | 10386037 | Insert Holder L | 1238203 | | | 1 | L(Qty)' |
| 51 | 10380439 | Slotted Socket Set Screw | P330500006 | M8X6(Flat Type) | | 1 | L(Qty)' |
| 52 | 10328305 | Spring Pin | P337030062 | 6X28AW | JIS | 1 | L(Qty)' |
| 53 | 10322120 | Socket Set Screw | P330590018 | M6X8(Dimple Type) | JIS | 2 | L(Qty)' |
| 54 | 10312317 | Fixed Insert L | 1230252 B | | | 1 | L(Qty)' |
| 55 | 10589206 | Hex Socket Cap Screw | P330220003 | M6X10 | | 2 | L(Qty)' |
| 56 | 10312329 | Movable Insert L | 1230253 B | | | 1 | L(Qty)' |
| 57 | 10328304 | Spring Pin | P337030055 | 6X14AW | JIS | 1 | L(Qty)' |

Unit No. 28

Saw Blade Guide(1)

| Index | Code | Parts Name | Drawing No. | Type | Maker | Q'ty | Note |
|-------|----------|--------------------------|-------------|-------------------|-------|------|---------|
| 58 | 10312594 | Pin | 1230290 | | | 1 | L(Qty)' |
| 59 | 10418979 | Backup Roller Holder | 1230254 A | | | 1 | L(Qty)' |
| 60 | 10300129 | Deep Groove Ball Bearing | 7922885--- | 6200LLU/LP03QT | NTN | 2 | L(Qty)' |
| 61 | 10312852 | Roller Pin | 0637054 | | | 2 | L(Qty)' |
| 62 | 10385735 | Sleeve | 1230255 A | | | 1 | L(Qty)' |
| 63 | 10330101 | Hex Socket Cap Screw | P330230008 | M8X30 | | 1 | L(Qty)' |
| 64 | 10383828 | Bearing Shaft 1 | 1109933 | | | 1 | L(Qty)' |
| 65 | 10383829 | Bearing Shaft 2 | 1109934 | | | 1 | L(Qty)' |
| 66 | 10383830 | Bearing Collar 1 | 1109935 | | | 1 | L(Qty)' |
| 67 | 10386035 | Bearing Collar 2 | 1238199 | | | 1 | L(Qty)' |
| 68 | 10300130 | Ball Bearing | 7922888--- | 6201LLU/LP03QT | | 2 | L(Qty)' |
| 69 | 10427991 | Nut | P332000006 | M10 | JIS | 2 | L(Qty)' |
| 70 | 10001520 | Spring Washer | P336050007 | 10 | JIS | 2 | L(Qty)' |
| 71 | 10383832 | Shim 1 | 1109937 | | | 2 | L(Qty)' |
| 72 | 10578740 | Shim 2 | 1109936 A | | | 2 | L(Qty)' |
| 73 | 10301149 | Plate (for Spring) | 1230256--B | | | 1 | L(Qty)' |
| 74 | 10324226 | Socket Set Screw | P330570035 | M10X30(Dog-end) | JIS | 1 | L(Qty)' |
| 75 | 10322120 | Socket Set Screw | P330590018 | M6X8(Dimple Type) | JIS | 1 | L(Qty)' |
| 76 | 10001840 | Cam Lever | 1230257 C | | | 1 | L(Qty)' |

Unit No. 28

Saw Blade Guide(1)

| Index | Code | Parts Name | Drawing No. | Type | Maker | Q'ty | Note |
|-------|----------|----------------------|-------------|-------------------|-------|------|---------|
| 77 | 10380430 | Parallel Pin | P337020155 | B-6X50 | JIS | 1 | L(Qty)' |
| 78 | 10322120 | Socket Set Screw | P330590018 | M6X8(Dimple Type) | JIS | 1 | L(Qty)' |
| 79 | 10583617 | Reamer Bolt M12 | 1230243 B | (M12X50) | | 1 | L(Qty)' |
| 80 | 10328337 | Hex Socket Cap Screw | P330250009 | M12X50 | | 1 | L(Qty)' |
| 81 | 10000829 | Spring Washer | P336050008 | 12 | JIS | 1 | L(Qty)' |
| 82 | 10380421 | Washer | 1238187 | | | 1 | L(Qty)' |
| 83 | 10419326 | Stopper | 1238226 | FB19X4.5 | | 1 | |
| 84 | 10342325 | Hex Socket Cap Screw | P330230004 | M8X15 | | 2 | |

Unit No. 29
Saw Blade Guide(2)-1/2 <HFA400W>

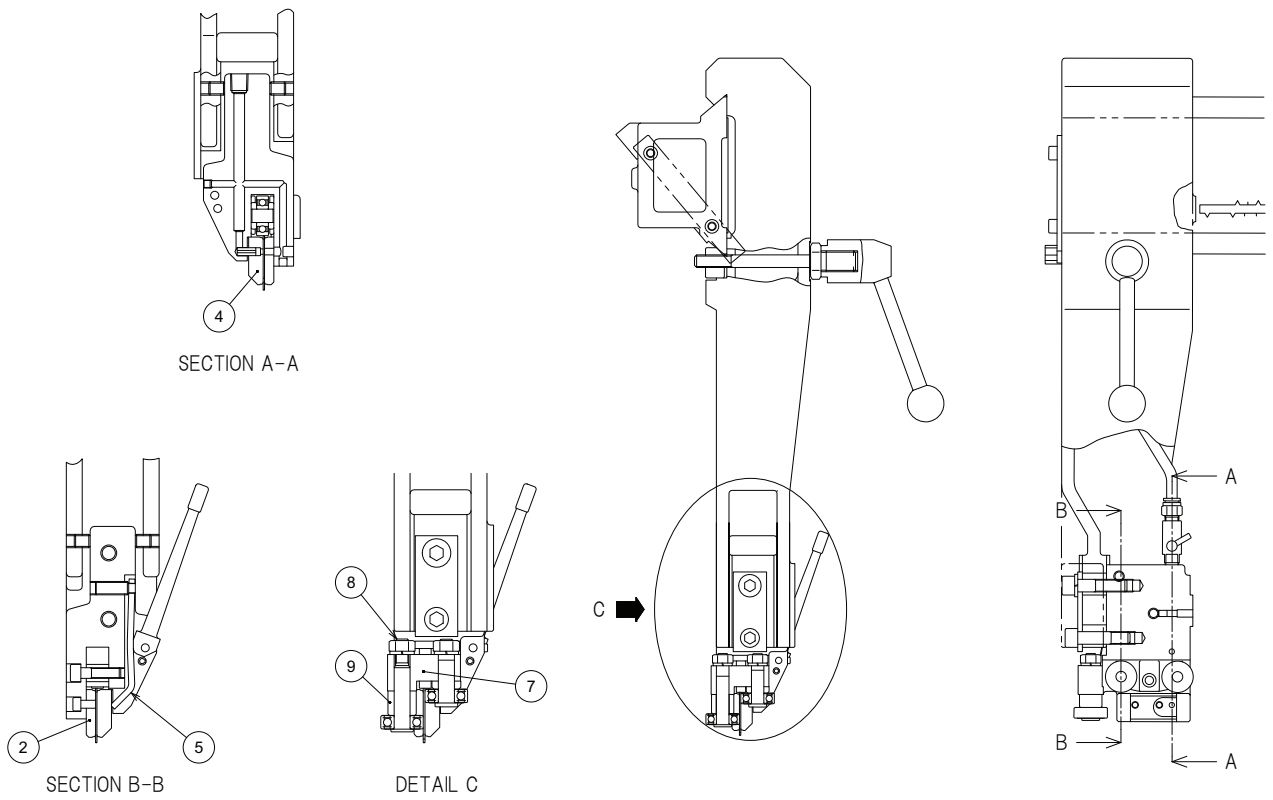

1230642B
(1278784--A)

Unit No. 29
Saw Blade Guide(2)-2/2 <HFA400W>

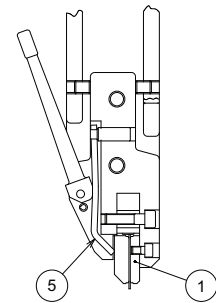
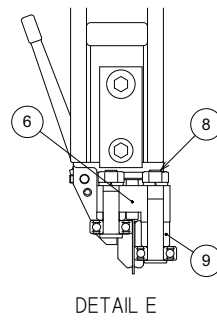
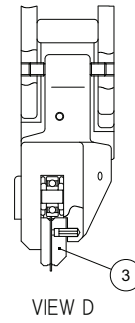
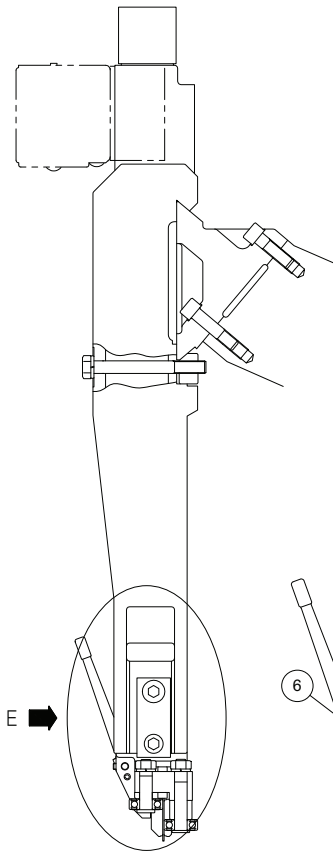
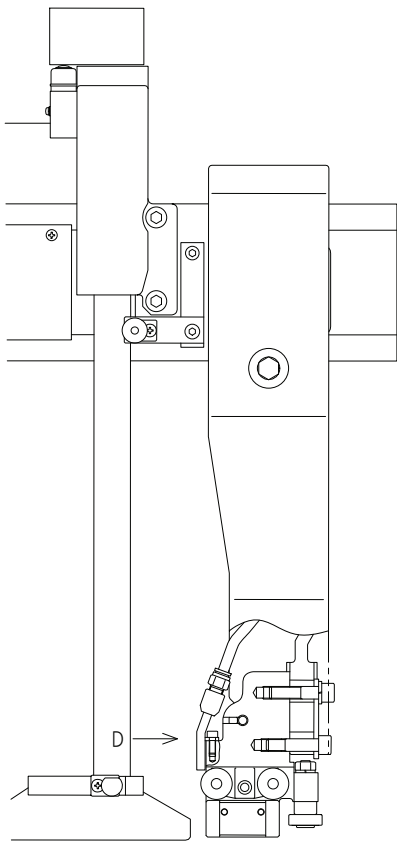

1230642B
(1278784--A)

Unit No. 29

Saw Blade Guide(2)

| Index | Code | Parts Name | Drawing No. | Type | Maker | Q'ty | Note |
|-------|----------|--------------------|-------------|------|-------|------|------|
| 1 | 10381240 | Fixed Insert R | 1231740 | | | 1 | |
| 2 | 10381245 | Fixed Insert L | 1231743 | | | 1 | |
| 3 | 10381242 | Movable Insert R | 1231741 | | | 1 | |
| 4 | 10381247 | Movable Insert L | 1231742 | | | 1 | |
| 5 | 10327708 | Plate (for Spring) | 1231732 | | | 2 | |
| 6 | 10419754 | Insert Holder R | 1231747 | | | 1 | |
| 7 | 10419757 | Insert Holder L | 1231748 | | | 1 | |
| 8 | 10419755 | Bearing Shaft 2 | 1238954 | | | 2 | |
| 9 | 10419756 | Bearing Collar 2 | 1238955 | | | 2 | |

Unit No. 30
Saw Blade Guide(3) <EU Specification Machine>

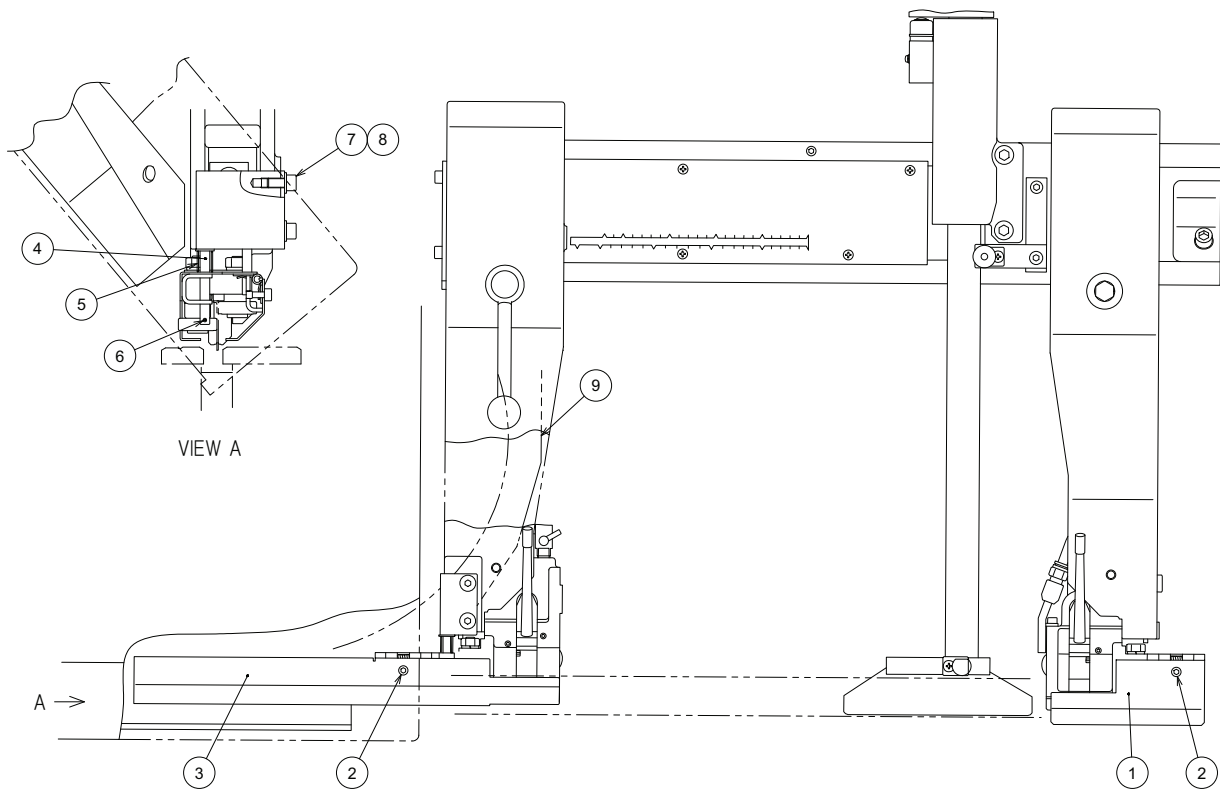

1230537F

Unit No. 30

Saw Blade Guide(3)

| Index | Code | Parts Name | Drawing No. | Type | Maker | Q'ty | Note |
|-------|----------|----------------------|-------------|----------------|-------|------|------|
| 1 | 10301256 | Blade Cover R | 1440914 D | | | 1 | |
| 2 | 10322615 | Hex Socket Cap Screw | 1200256 A | M6X16 | | 2 | |
| 3 | 10301257 | Blade Cover L | 1440915 F | | | 1 | |
| 4 | 10301258 | Spring Guide | 1440916 D | | | 1 | |
| 5 | 10315205 | Feedback Spring | 0654330 A | | | 1 | |
| 6 | 10331237 | Spring Pin | P337030013 | 3X14AW | JIS | 1 | |
| 7 | 10343103 | Hex Socket Cap Screw | P330230005 | M8X16 | JIS | 2 | |
| 8 | 10301282 | Washer | P336000041 | 8(Small Round) | JIS | 3 | |
| 9 | 10583609 | Driven Support Cover | 1230658 B | | | 1 | |

Unit No. 31
 Saw Blade Guide(4)-1/2 <Quick Approach>

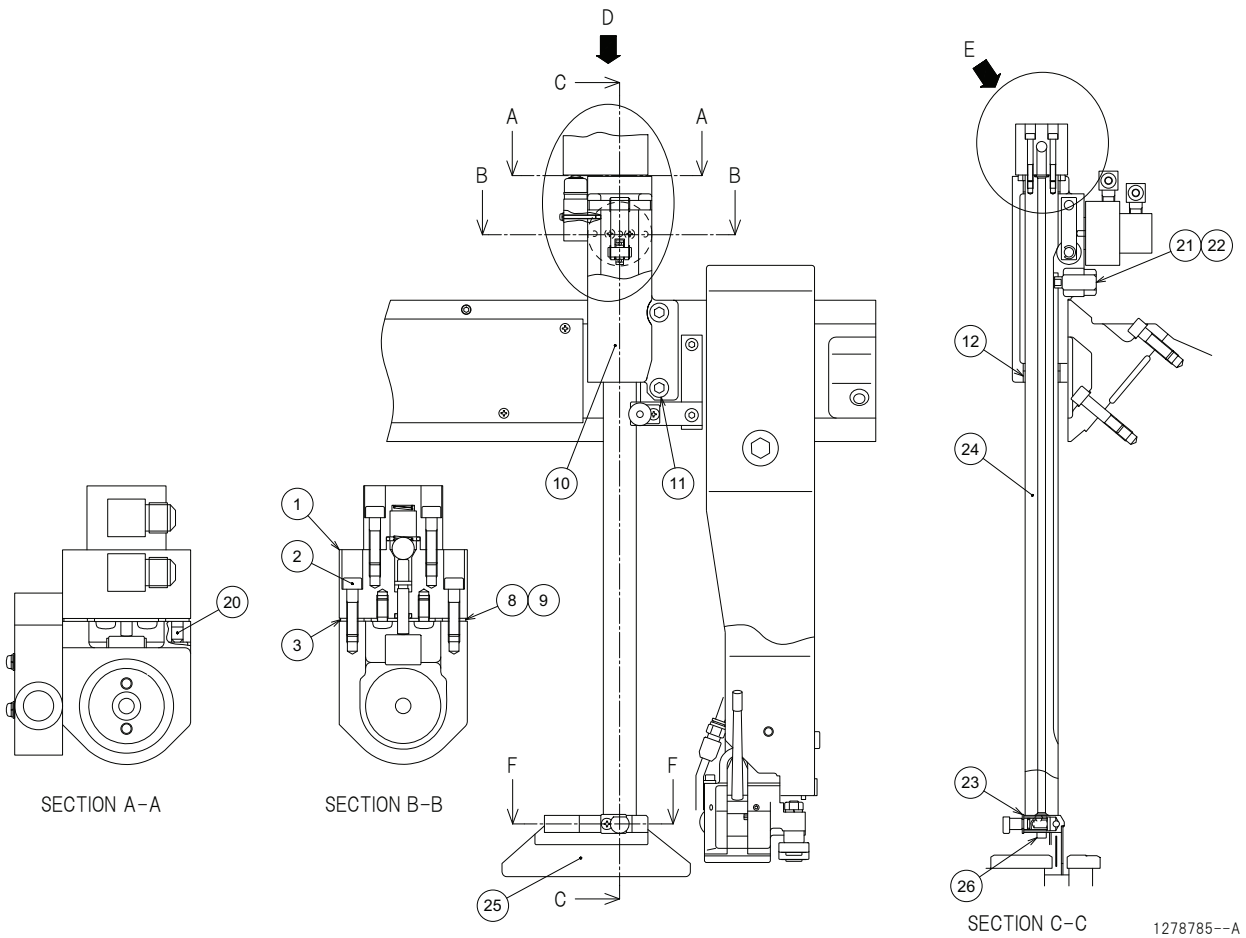

1278785--A

Unit No. 31
Saw Blade Guide(4)-2/2 <Quick Approach>

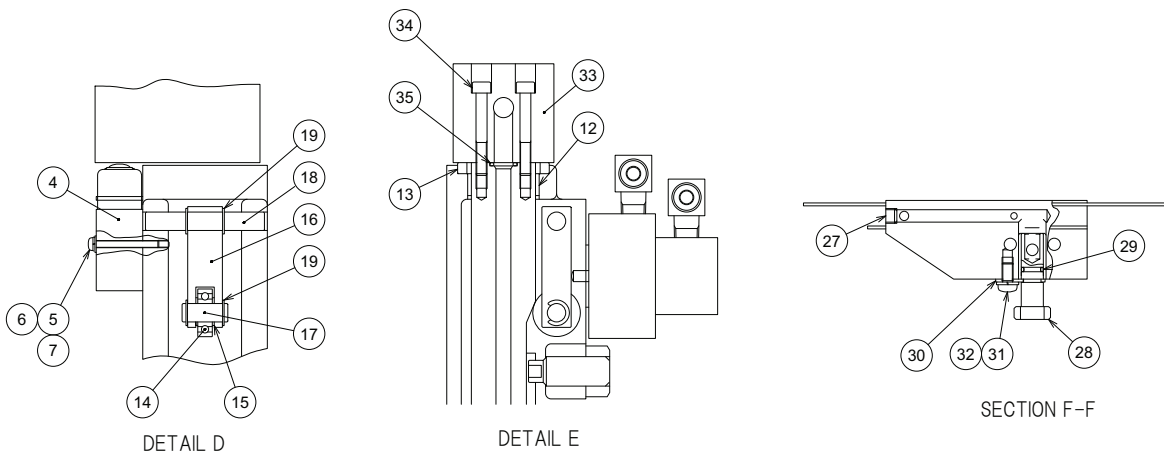

Unit No. 31

Saw Blade Guide(4)

| Index | Code | Parts Name | Drawing No. | Type | Maker | Q'ty | Note |
|-------|----------|--------------------------|-------------|----------------|--------------|------|------|
| 1 | 10301276 | Quick Approach Valve | 7922619 | | YUATSU SEIKO | 1 | |
| 2 | 10324622 | Hex Socket Cap Screw | P330220011 | M6X25 | | 2 | |
| 3 | 10321922 | Washer | P336000005 | 6(Normal) | JIS | 2 | |
| 4 | 10204724 | Limit Switch | P828012022 | ZE-N-2 | OMRON | 1 | |
| 5 | 10328314 | Pan Head Screw | P334100027 | M4X35 | JIS | 2 | |
| 6 | 10318527 | Spring Washer | P336050003 | 4 | JIS | 2 | |
| 7 | 10337110 | Washer | P336000003 | 4(Small Round) | JIS | 2 | |
| 8 | 10328161 | Shim 0.1T | 1230287 | | | 6 | |
| 9 | 10328162 | Shim 0.5T | 1230288 | | | 6 | |
| 10 | 10419327 | Approach Bar Guide | 1230278 E | | | 1 | |
| 11 | 10328331 | Hex Socket Cap Screw | P330250007 | M12X40 | | 2 | |
| 12 | 10581661 | Plain Bearing | P407003179 | DUB3512 | DAIDO METAL | 2 | |
| 13 | 10328166 | Urethane Cushion | 1230289 | | | 1 | |
| 14 | 10380456 | Deep Groove Ball Bearing | P400010533 | 6000ZZ | NSK & others | 1 | |
| 15 | 10312901 | Locating Snap Ring | P406108034 | STW-11 | OCHIAI | 2 | |
| 16 | 10300540 | Roller Lever | RB00468--A | | | 1 | |
| 17 | 10301125 | Roller Pin | RB01915--A | | | 1 | |
| 18 | 10301454 | Roller Lever Pin | RB01916--A | | | 1 | |
| 19 | 10380457 | Locating Snap Ring | P406100005 | E-7 | JIS | 4 | |

Unit No. 31

Saw Blade Guide(4)

| Index | Code | Parts Name | Drawing No. | Type | Maker | Q'ty | Note |
|-------|----------|----------------------|-------------|-------------------|-------|------|------|
| 20 | 10322120 | Socket Set Screw | P330590018 | M6X8(Dimple Type) | JIS | 1 | |
| 21 | 10328239 | Guide Bolt | 1230291 | | | 1 | |
| 22 | 10421756 | Nut | P332000009 | M16 | JIS | 1 | |
| 23 | 10328163 | Shim | 1230294 | | | 1 | |
| 24 | 10380450 | Approach Bar | 1238182 A | | | 1 | |
| 25 | 10301455 | Filler | RB01920--A | | | 1 | |
| 26 | 10324622 | Hex Socket Cap Screw | P330220011 | M6X25 | | 2 | |
| 27 | 10378145 | Socket Set Screw | P330550131 | M8X6(Flat Type) | JIS | 1 | |
| 28 | 10378153 | Cock | 1238198 | | | 1 | |
| 29 | 10314519 | O Ring | P590000007 | P9 | | 1 | |
| 30 | 10312046 | Stopper Plate | 1230190 | | | 1 | |
| 31 | 10322226 | Pan Head Screw | P334100055 | M6X12 | JIS | 1 | |
| 32 | 10310351 | Spring Washer | P336050005 | 6 | JIS | 1 | |
| 33 | 10380452 | LS Dog | 1238192 | | | 1 | |
| 34 | 10310362 | Hex Socket Cap Screw | P330220015 | M6X45 | | 2 | |
| 35 | 10206605 | O Ring | P590000010 | P11 | | 1 | |

Unit No. 32
Saw Blade Guide(5) <HFA400W>

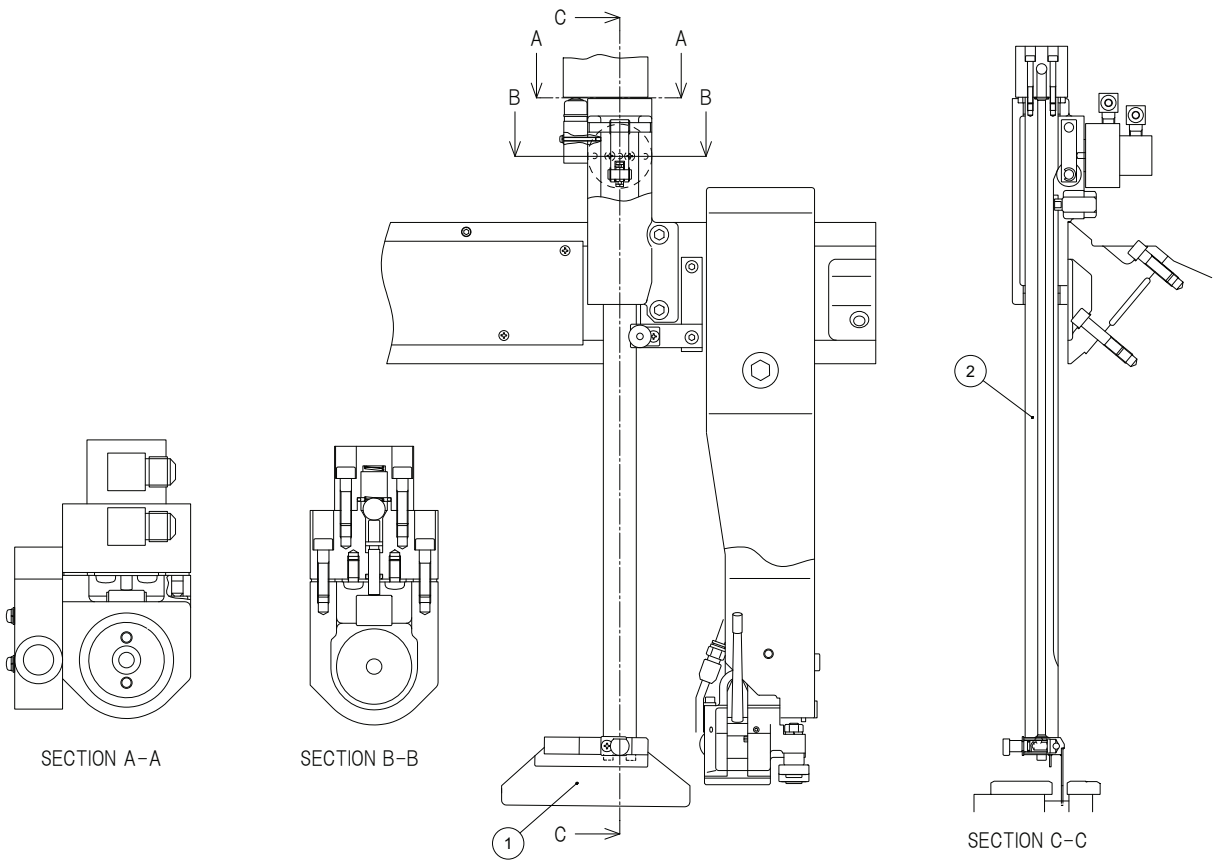

1278785--A

Unit No. 32

Saw Blade Guide(5)

| Index | Code | Parts Name | Drawing No. | Type | Maker | Q'ty | Note |
|-------|----------|--------------|-------------|------|-------|------|----------|
| 1 | 10301506 | Filler | RB02366--A | | | 1 | for 41mm |
| 2 | 10379531 | Approach Bar | 1286528 | | | 1 | for 41mm |

Unit No. 33
Saw Blade Guide(6) <Stopper>

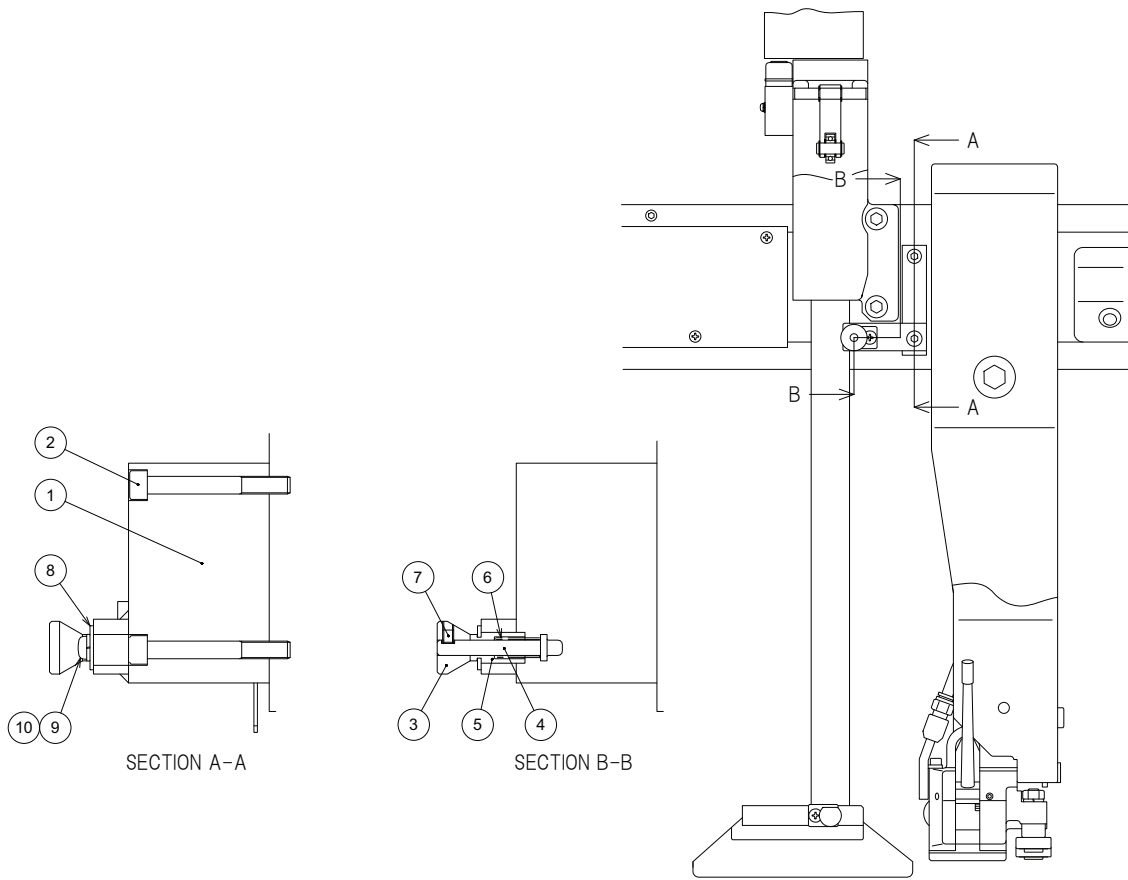

1278786---
(1278785--A)

Unit No. 33

Saw Blade Guide(6)

| Index | Code | Parts Name | Drawing No. | Type | Maker | Q'ty | Note |
|-------|----------|----------------------|-------------|-----------------|---------------|------|------|
| 1 | 10380463 | Block | 1238211 B | | | 1 | |
| 2 | 10443025 | Hex Socket Cap Screw | P330230016 | M8X70 | | 2 | |
| 3 | 10380460 | Knob | 1238189 | | | 1 | |
| 4 | 10380461 | Shaft | 1238190 A | | | 1 | |
| 5 | 10380462 | Holder | 1238191 A | | | 1 | |
| 6 | 10301278 | Coil Spring | P320003001 | AP090-023-0.8 | SHOWA HATSUJO | 1 | |
| 7 | 10329312 | Socket Set Screw | P330550016 | M5X6(Flat Type) | JIS | 1 | |
| 8 | 10312046 | Stopper Plate | 1230190 | | | 1 | |
| 9 | 10322226 | Pan Head Screw | P334100055 | M6X12 | JIS | 1 | |
| 10 | 10310351 | Spring Washer | P336050005 | 6 | JIS | 1 | |

Unit No. 34
Hydraulic(1)

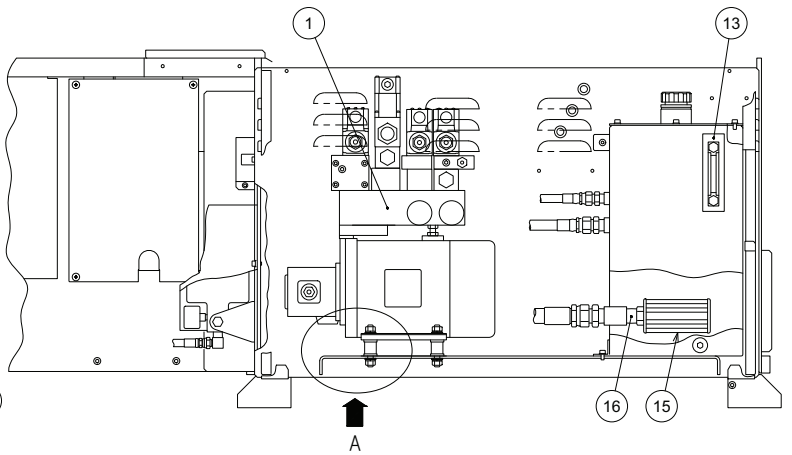
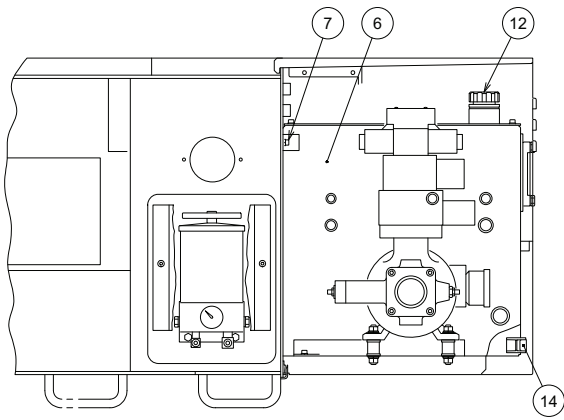
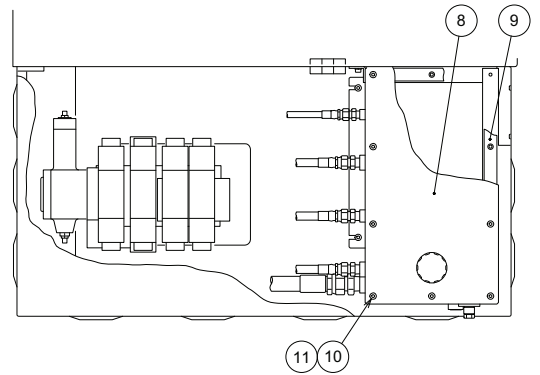
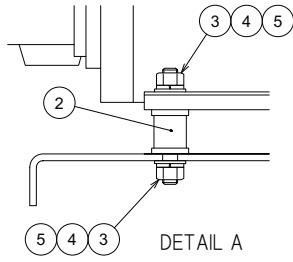

1278790--B

Unit No. 34
Hydraulic(1)

| Index | Code | Parts Name | Drawing No. | Type | Maker | Q'ty | Note |
|-------|----------|----------------------|-------------|---------------------------|-------------|------|------|
| 1 | 10302007 | Hydraulic Unit | RB01951--A | | | 1 | |
| 2 | 10583644 | Vibration Isolator | 124469705B | | | 4 | |
| 3 | 10325021 | Washer | P336000007 | 10(Normal) | JIS | 8 | |
| 4 | 10427991 | Nut | P332000006 | M10 | JIS | 8 | |
| 5 | 10001520 | Spring Washer | P336050007 | 10 | JIS | 8 | |
| 6 | 10419330 | Hydraulic Tank | 1440411 | | | 1 | |
| 7 | 10323201 | Hex Socket Cap Screw | P330220004 | M6X12 | JIS | 4 | |
| 8 | 10301465 | Tank Cover | RB01953--A | | | 1 | |
| 9 | 10419332 | Rubber Sheet | 1440413 | | | 1 | |
| 10 | 10323201 | Hex Socket Cap Screw | P330220004 | M6X12 | JIS | 10 | |
| 11 | 10310351 | Spring Washer | P336050005 | 6 | JIS | 10 | |
| 12 | 10583645 | Oil Cap | 124469706B | YS-70(L)SFN-57-1-1/2 | ELESA | 1 | |
| 13 | 10580109 | Level Gauge | P600108033 | KLA-100SN-A (Float : Red) | KYOWA | 1 | |
| 14 | 10301299 | Plug for Piping | P580208004 | GM-1/2 | GOSHO Works | 1 | |
| 15 | 10583647 | Hydraulic Filter | 124469708B | SFT-06-150W | YU-XING | 1 | |
| 16 | 10329330 | Barrel Nipple | P580040005 | 3/4 | | 1 | |

Unit No. 35
Hydraulic(2) <Hydraulic Unit>

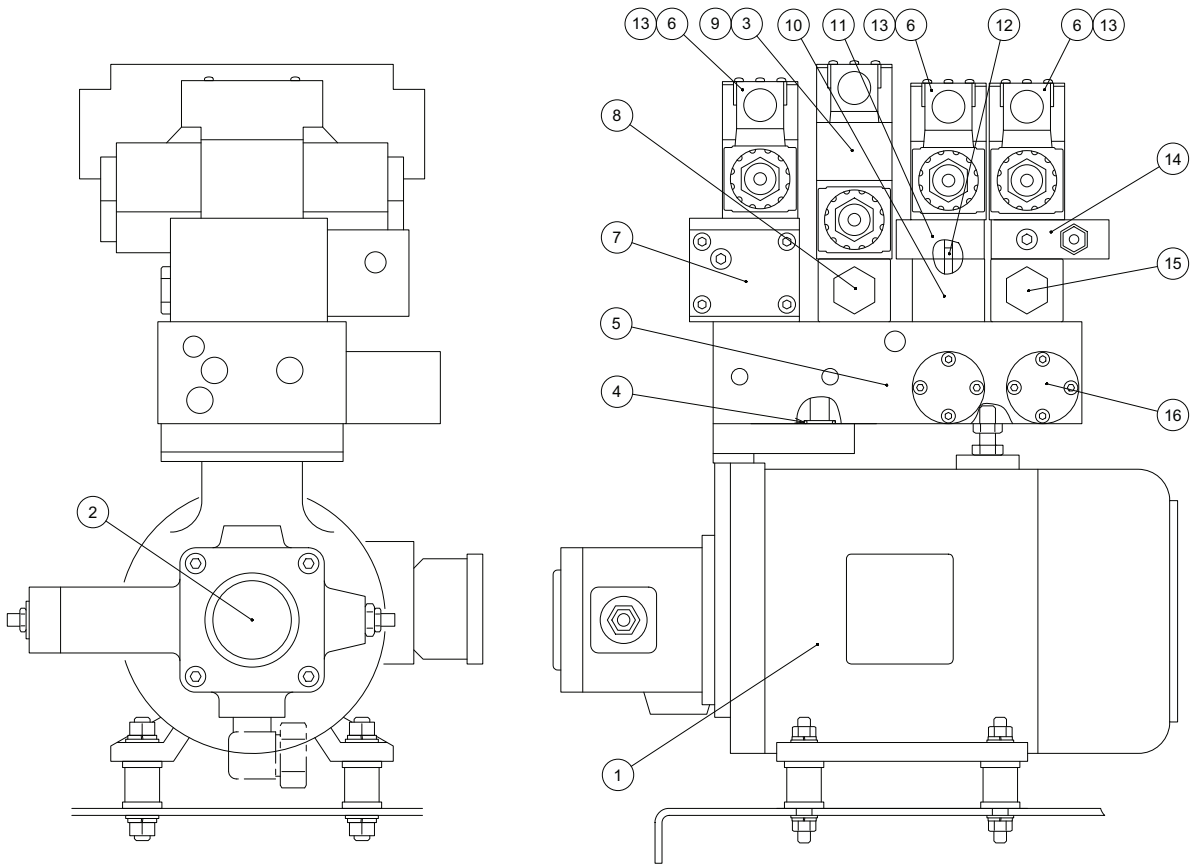

Unit No. 35
Hydraulic(2)

| Index | Code | Parts Name | Drawing No. | Type | Maker | Q'ty | Note |
|-------|----------|------------------------------|-------------|----------------------|---------|------|------|
| 1 | 10301461 | Pump Motor | RB0195101- | 1.5kW§1440rpm | | 1 | |
| 2 | 10301462 | Pump | RB0195102- | VD1-30F-A3 | ASADA | 1 | |
| 3 | 10561516 | Hex Socket Cap Screw | P330210023 | M5X85 | MOURI | 4 | |
| 4 | 10001117 | O Ring | P590000020 | P22 | | 1 | |
| 5 | 10300559 | Manifold | RB0050805B | | | 1 | |
| 6 | 10300565 | Solenoid Valve | RB0050812- | D4-02-3C4-D2 | ASADA | 3 | |
| 7 | 10300566 | Filter | RB0050813- | 1309.3-00 | | 1 | |
| 8 | 10300567 | Modular Valve | RB0050814- | MPW-02A | | 1 | |
| 9 | 10301563 | Proportional Solenoid Valve | 7720201--A | EPDG1-3-33C-20-A1-31 | TOKIMEC | 1 | |
| 10 | 10300569 | Modular Valve | RB0050816- | MCP-02-A | | 1 | |
| 11 | 10300562 | Middle Plate | RB0050808A | 80149 | | 1 | |
| 12 | 10301463 | Orifice | RB0195115- | 1309.5 | | 2 | |
| 13 | 10300134 | Hex Socket Cap Screw | P330210020 | M5X110 | MOURI | 12 | |
| 14 | 10301464 | Sub Plate | RB0195118- | 1309.8 | | 1 | |
| 15 | 10300568 | Modular Valve | RB0050815- | MPA-02A | | 1 | |
| 16 | 10300570 | Differential Pressure Switch | RB0050817- | 1309-2 | | 2 | |

Unit No. 36
Hydraulic(3) <Power Source Voltage:230/460V>

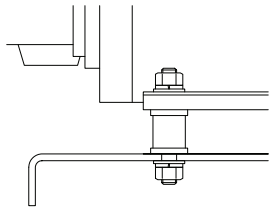

DETAIL A

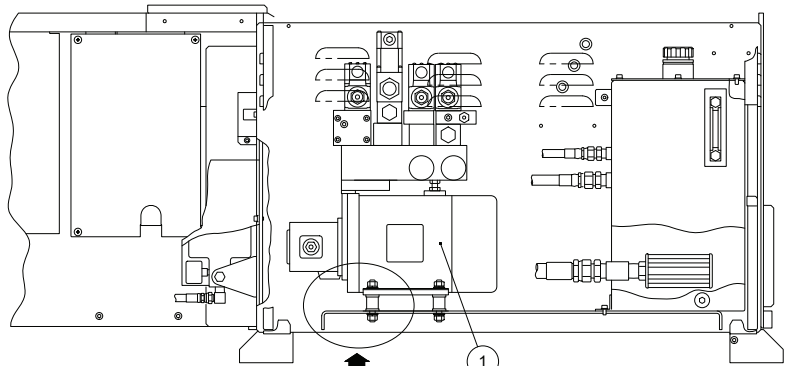
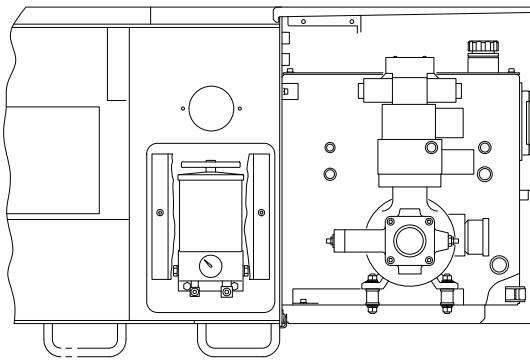
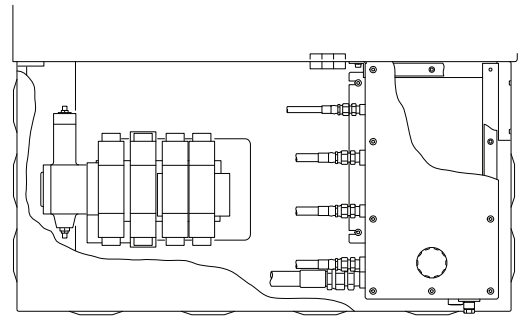

A

1

RB02427--
(1278790--B)

Unit No. 36
Hydraulic(3)

| Index | Code | Parts Name | Drawing No. | Type | Maker | Q'ty | Note |
|-------|----------|---------------|-------------|----------------------|-------|------|------|
| 1 | 10301516 | Pump Motor US | RB02427--- | 1.5kW 230/460V(60Hz) | | 1 | |

Unit No. 37
Hydraulic(4) <Power Source Voltage:400V>

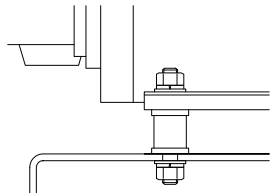

DETAIL A

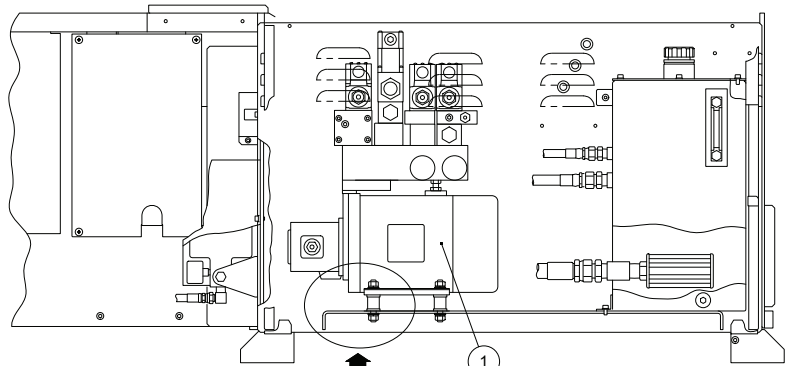
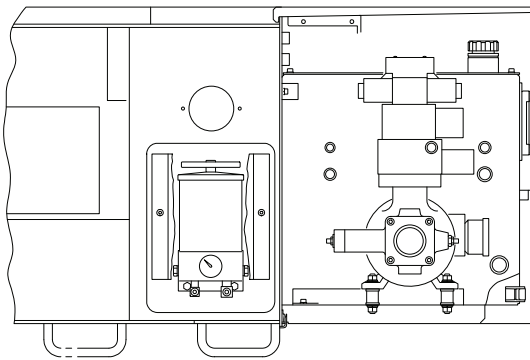
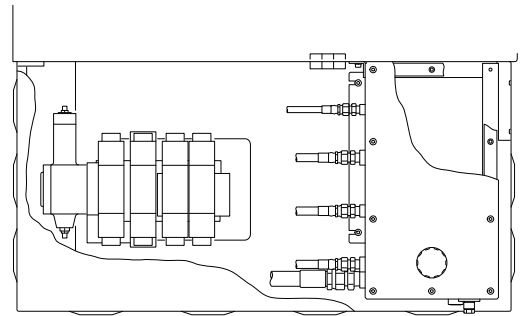

A

1

RB02477---
(1278790--B)

Unit No. 37
Hydraulic(4)

| Index | Code | Parts Name | Drawing No. | Type | Maker | Q'ty | Note |
|-------|----------|-----------------|-------------|------------------|-------|------|------|
| 1 | 10301524 | Pump Motor 400V | RB02477--- | 1.5kW 400V(50Hz) | | 1 | |

Unit No. 38
 Hydraulic(5)-1/2 <Piping>

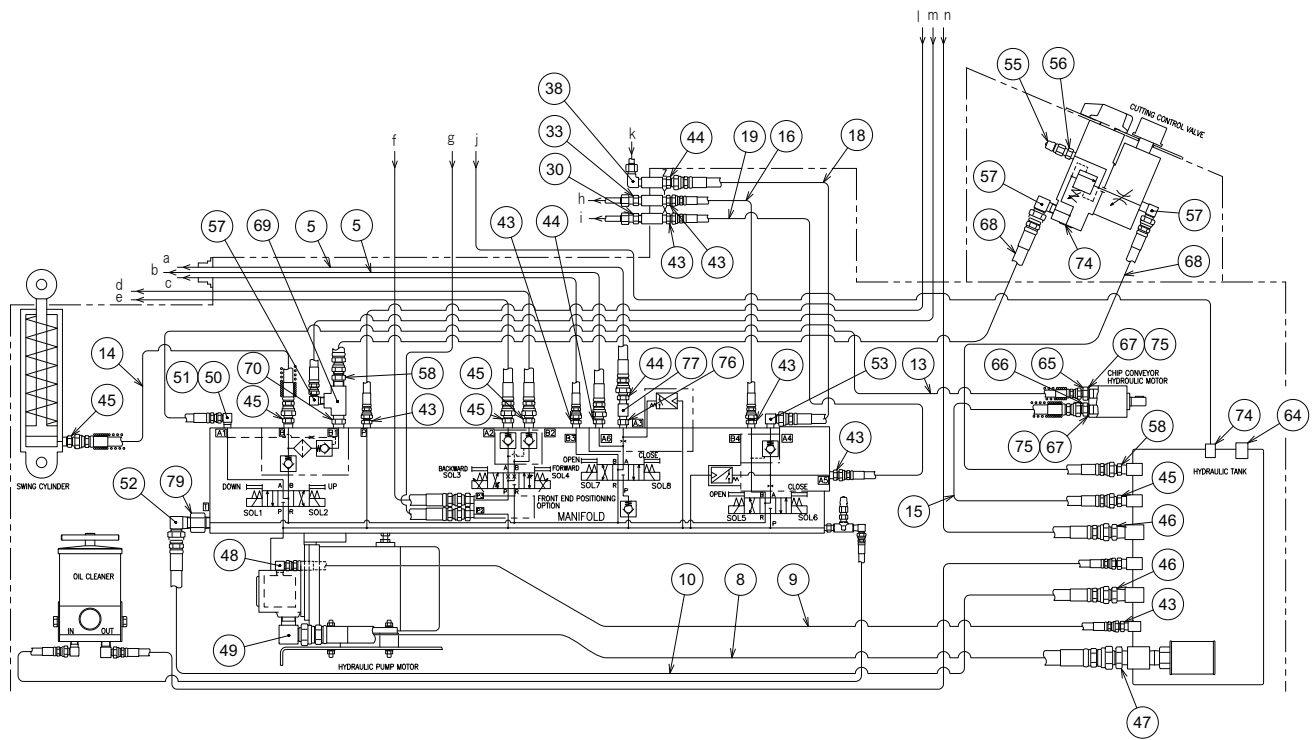

1278791--C

Unit No. 38
 Hydraulic(5)-2/2 <Piping>

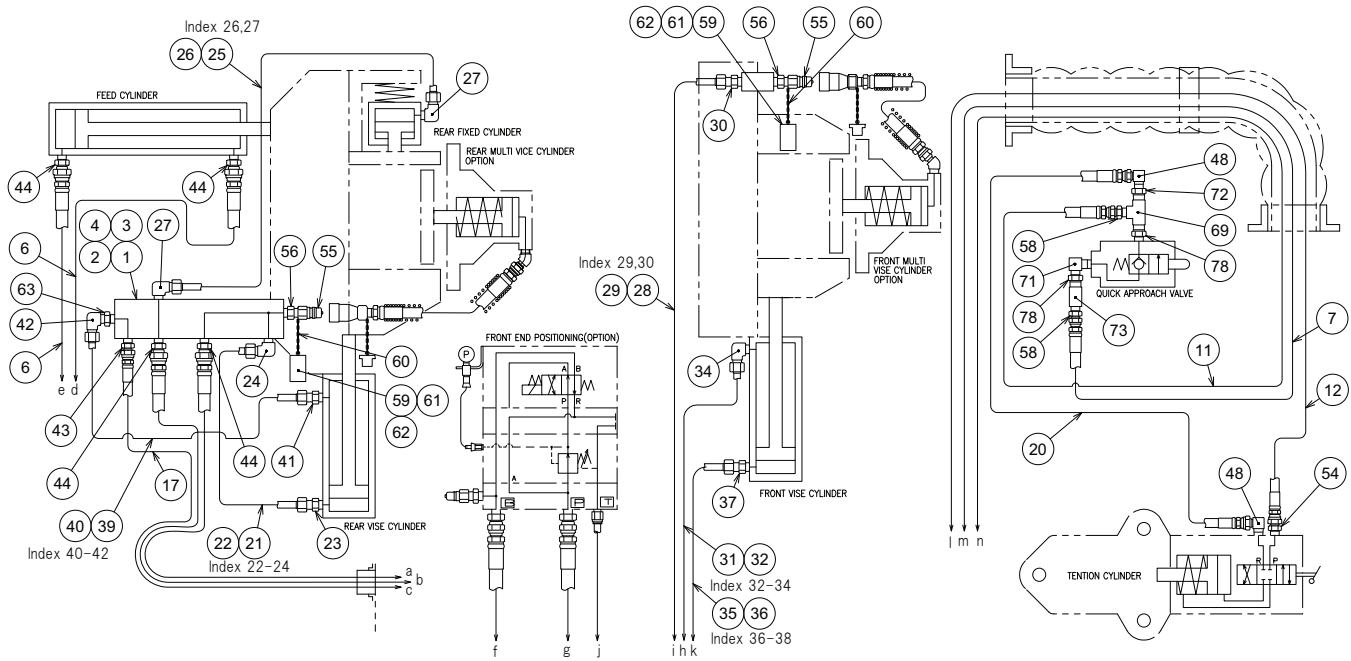

1278791--C

Unit No. 38

Hydraulic(5)

| Index | Code | Parts Name | Drawing No. | Type | Maker | Q'ty | Note |
|-------|----------|----------------------|-------------|-----------|-------|------|------|
| 1 | 10378668 | Manifold Block A | 1238679 B | | | 1 | |
| 2 | 10326113 | Hex Socket Cap Screw | P330220016 | M6X50 | | 2 | |
| 3 | 10321922 | Washer | P336000005 | 6(Normal) | JIS | 2 | |
| 4 | 10310351 | Spring Washer | P336050005 | 6 | JIS | 2 | |
| 5 | 10583648 | Hydraulic Hose 1 | 1230714 B | | | 2 | |
| 6 | 10378172 | Hydraulic Hose 2 | 1238256 | | | 2 | |
| 7 | 10380512 | Hydraulic Hose 3 | 1238257 A | | | 1 | |
| 8 | 10301466 | Hydraulic Hose 4 | RB01965--B | | | 1 | |
| 9 | 10301467 | Hydraulic Hose 5 | RB01966--A | | | 1 | |
| 10 | 10378206 | Hydraulic Hose 6 | 1238260 | | | 1 | |
| 11 | 10380513 | Hydraulic Hose 7 | 1238261 A | | | 1 | |
| 12 | 10378207 | Hydraulic Hose 9 | 1238263 A | | | 1 | |
| 13 | 10378208 | Hydraulic Hose 10 | 1238264 A | | | 1 | |
| 14 | 10378209 | Hydraulic Hose 11 | 1238265 A | | | 1 | |
| 15 | 10378210 | Hydraulic Hose 12 | 1238266 A | | | 1 | |
| 16 | 10419522 | Hydraulic Hose 13 | 1244710 | | | 1 | |
| 17 | 10583650 | Hydraulic Hose 14 | 1230715 B | | | 1 | |
| 18 | 10419523 | Hydraulic Hose 15 | 1244711 | | | 1 | |
| 19 | 10419524 | Hydraulic Hose 16 | 1244712 | | | 1 | |

Unit No. 38
Hydraulic(5)

| Index | Code | Parts Name | Drawing No. | Type | Maker | Q'ty | Note |
|-------|----------|------------------------|-------------|-----------------------------|---------------|------|------------------|
| 20 | 10419334 | Hydraulic Hose 17 | 1238271 B | | | 1 | |
| 21 | 10301474 | Pipe | RB02005--- | | | 1 | with Index 22-24 |
| 22 | 10301475 | Pipe | RB0200501- | | | 1 | |
| 23 | 10589417 | Bite Type Pipe Fitting | P585032029 | KCT10-020E (Male Connector) | IHARA Science | 1 | |
| 24 | 10583658 | Bite Type Pipe Fitting | P585062056 | KLN10-020E | IHARA Science | 1 | |
| 25 | 10301476 | Pipe | RB02006--- | | | 1 | with Index 26,27 |
| 26 | 10301477 | Pipe | RB0200601- | | | 1 | |
| 27 | 10583658 | Bite Type Pipe Fitting | P585062056 | KLN10-020E | IHARA Science | 2 | |
| 28 | 10301478 | Pipe | RB02007--A | | | 1 | with Index 29,30 |
| 29 | 10301479 | Pipe | RB0200701A | | | 1 | |
| 30 | 10589417 | Bite Type Pipe Fitting | P585032029 | KCT10-020E (Male Connector) | IHARA Science | 2 | |
| 31 | 10301480 | Pipe | RB02008--- | | | 1 | with Index 32-34 |
| 32 | 10301481 | Pipe | RB0200801- | | | 1 | |
| 33 | 10589417 | Bite Type Pipe Fitting | P585032029 | KCT10-020E (Male Connector) | IHARA Science | 1 | |
| 34 | 10583658 | Bite Type Pipe Fitting | P585062056 | KLN10-020E | IHARA Science | 1 | |
| 35 | 10301482 | Pipe | RB02009--A | | | 1 | with Index 36-38 |
| 36 | 10301483 | Pipe | RB0200901A | | | 1 | |
| 37 | 10589417 | Bite Type Pipe Fitting | P585032029 | KCT10-020E (Male Connector) | IHARA Science | 1 | |
| 38 | 10583658 | Bite Type Pipe Fitting | P585062056 | KLN10-020E | IHARA Science | 1 | |

Unit No. 38
Hydraulic(5)

| Index | Code | Parts Name | Drawing No. | Type | Maker | Q'ty | Note |
|-------|----------|------------------------|-------------|-----------------------------|---------------|------|------------------|
| 39 | 10301484 | Pipe | RB02011--- | | | 1 | with Index 40-42 |
| 40 | 10301485 | Pipe | RB0201101- | | | 1 | |
| 41 | 10589417 | Bite Type Pipe Fitting | P585032029 | KCT10-020E (Male Connector) | IHARA Science | 1 | |
| 42 | 10583658 | Bite Type Pipe Fitting | P585062056 | KLN10-020E | IHARA Science | 1 | |
| 43 | 10300596 | Male-Male Adapter | RB0054011A | PT1/4-PF1/4 | | 8 | |
| 44 | 10300597 | Male-Male Adapter | RB0054013B | PT1/4-PF3/8 | | 7 | |
| 45 | 10300598 | Male-Male Adapter | RB0054014A | PT3/8-PF3/8 | | 5 | |
| 46 | 10300601 | Male-Male Adapter | RB0054017A | PT1/2-PF1/2 | | 2 | |
| 47 | 10300602 | Male-Male Adapter | RB0054018A | PT3/4-PF3/4 | | 1 | |
| 48 | 10300603 | Elbow | RB0054021A | PT1/4-PF1/4 | | 3 | |
| 49 | 10301469 | Elbow | RB0198901- | PT3/4-PF3/4 | | 1 | |
| 50 | 10300604 | Elbow | RB0054022A | PT1/4-PF1/4 | | 1 | |
| 51 | 10300609 | Bolt for Adapter | RB0054031- | | | 1 | |
| 52 | 10300606 | Elbow | RB0054025A | PT1/2-PF1/2 | | 1 | |
| 53 | 10301126 | Elbow | RB0198903- | PT1/4-PF3/8 | | 1 | |
| 54 | 10300624 | Check Nipple | RB00541--A | | | 1 | |
| 55 | 10375464 | Quick Connect Joint | P589026080 | 2P-BSBM | NITTO KOHKI | 3 | |
| 56 | 10329329 | Nipple | P580020002 | 1/4 | JIS | 3 | |
| 57 | 10301472 | Elbow | RB0198908- | PT3/8-PF1/2 | | 3 | |

Unit No. 38
Hydraulic(5)

| Index | Code | Parts Name | Drawing No. | Type | Maker | Q'ty | Note |
|-------|----------|-------------------|-------------|------------------|----------|------|------|
| 58 | 10301470 | Male-Male Adapter | RB0198904- | PT3/8-PF1/2 | | 4 | |
| 59 | 10300626 | Rubber Cap | RB00543--- | | | 2 | |
| 60 | 10300613 | Chain | RB0054035- | L=150 | | 2 | |
| 61 | 10376123 | Split Pin | P337000044 | 4X40(Mild Steel) | JIS | 2 | |
| 62 | 10375463 | Cable Band | P381058035 | SKB-2M | KITAGAWA | 2 | |
| 63 | 10301298 | Socket for Piping | P580000053 | SXS-82820 | KOYO | 1 | |
| 64 | 10380545 | Plug | P580208013 | PT-3/8 | | 1 | |
| 65 | 10300610 | Coupling | RB0054032A | G3/8-G1/4 | | 1 | |
| 66 | 10301471 | Coupling | RB0198905- | G3/8-G3/8 | | 1 | |
| 67 | 10300611 | Copper Washer | RB0054033- | | | 2 | |
| 68 | 10419335 | Hydraulic Hose | 1427744 | 1/2X4000 | | 2 | |
| 69 | 10589413 | Tee | P580100003 | 3/8 | JIS | 2 | |
| 70 | 10378201 | Nipple | P580020003 | 3/8 | JIS | 1 | |
| 71 | 10301473 | Elbow | RB0198909- | 1/4 | | 1 | |
| 72 | 10589714 | Bush for Piping | P580010002 | 3/8X1/4 | JIS | 1 | |
| 73 | 10301297 | Socket for Piping | P580000003 | 3/8 | JIS | 1 | |
| 74 | 10300171 | Plug for Piping | P580208021 | PT-1/4 | | 2 | |
| 75 | 10300615 | O Ring | RB0054038- | 14X1.8 | | 2 | |
| 76 | 10329329 | Nipple | P580020002 | 1/4 | JIS | 1 | |

Unit No. 38
Hydraulic(5)

| Index | Code | Parts Name | Drawing No. | Type | Maker | Q'ty | Note |
|-------|----------|-------------------|-------------|------------|---------------|------|------|
| 77 | 10329217 | Socket for Piping | P580000002 | 1/4 | JIS | 1 | |
| 78 | 10003931 | Nipple | P580020010 | 3/8X1/4 | JIS | 2 | |
| 79 | 10300167 | Socket for Piping | P580002018 | SSS04-040J | IHARA Science | 1 | |

Unit No. 39
Hydraulic(6) <Pressure Control Valve>

1 Index 2-24

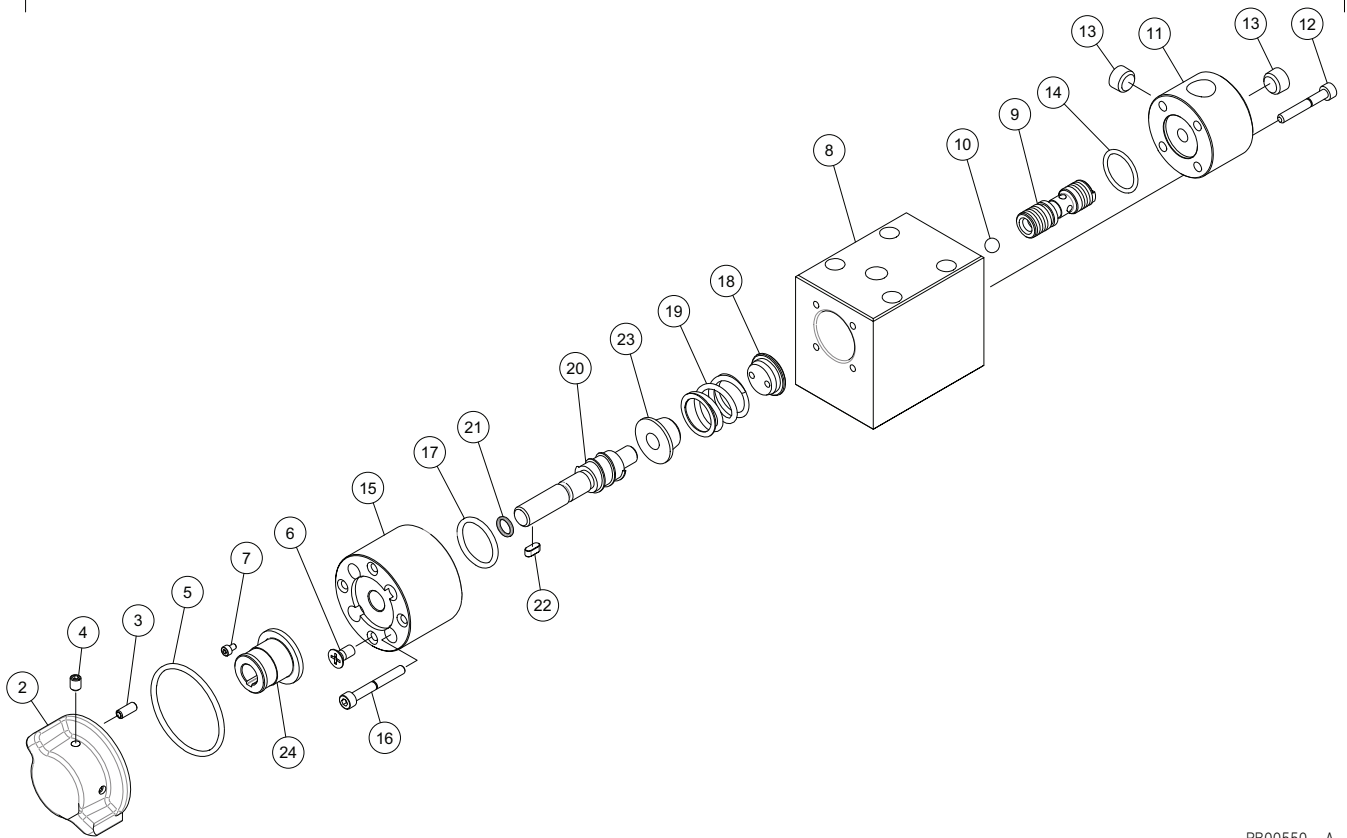

Unit No. 39
Hydraulic(6)

| Index | Code | Parts Name | Drawing No. | Type | Maker | Q'ty | Note |
|-------|----------|----------------------------------|-------------|--|-------|------|-----------------|
| 1 | 10302098 | Vise Pressure Control Valve ASSY | SBS0130--- | RB00551---, RB00552---, RB00553--- others | | 1 | with Index 2-24 |
| 2 | 10300629 | Dial | RB00551--- | | | 1 | |
| 3 | 10329648 | Spring Pin | P337030037 | 5X12AW | JIS | 1 | |
| 4 | 10322120 | Socket Set Screw | P330590018 | M6X8(Dimple Type) | JIS | 2 | |
| 5 | 10332957 | O Ring | P590010006 | G50 | | 1 | |
| 6 | 10330114 | Flat Head Screw | P334110026 | M6X12 | JIS | 4 | |
| 7 | 10372064 | Hex Socket Cap Screw | P330200037 | M3X5 | JIS | 2 | |
| 8 | 10300630 | Body | RB00552--- | | | 1 | |
| 9 | 10300631 | Spool | RB00553--- | | | 1 | |
| 10 | 10315427 | Steel Ball (for Bearing) | P406000005 | 5/16 | JIS | 1 | |
| 11 | 10300632 | Head Cap | RB00554--- | | | 1 | |
| 12 | 10329636 | Hex Socket Cap Screw | P330210012 | M5X35 | | 4 | |
| 13 | 10300171 | Plug for Piping | P580208021 | PT-1/4 | | 2 | |
| 14 | 10001117 | O Ring | P590000020 | P22 | | 1 | |
| 15 | 10300633 | End Cap | RB00555--A | | | 1 | |
| 16 | 10329637 | Hex Socket Cap Screw | P330210013 | M5X40 | | 4 | |
| 17 | 10316424 | O Ring | P590010001 | G25 | | 1 | |
| 18 | 10300634 | Spring Washer | RB00556--- | | | 1 | |
| 19 | 10300635 | Spring | RB00557--- | | | 1 | |

Unit No. 39
Hydraulic(6)

| Index | Code | Parts Name | Drawing No. | Type | Maker | Q'ty | Note |
|-------|----------|---------------|-------------|----------------------------|-------|------|------|
| 20 | 10300636 | Adjust Screw | RB00558--- | | | 1 | |
| 21 | 10314519 | O Ring | P590000007 | P9 | | 1 | |
| 22 | 10380544 | Parallel Key | P436000079 | 4X4X10(Double Ended Round) | JIS | 1 | |
| 23 | 10300637 | Spring Washer | RB00559--- | | | 1 | |
| 24 | 10300639 | Collar | RB00561--- | | | 1 | |

Unit No. 40
 Hydraulic(7) <Flow Control Valve>

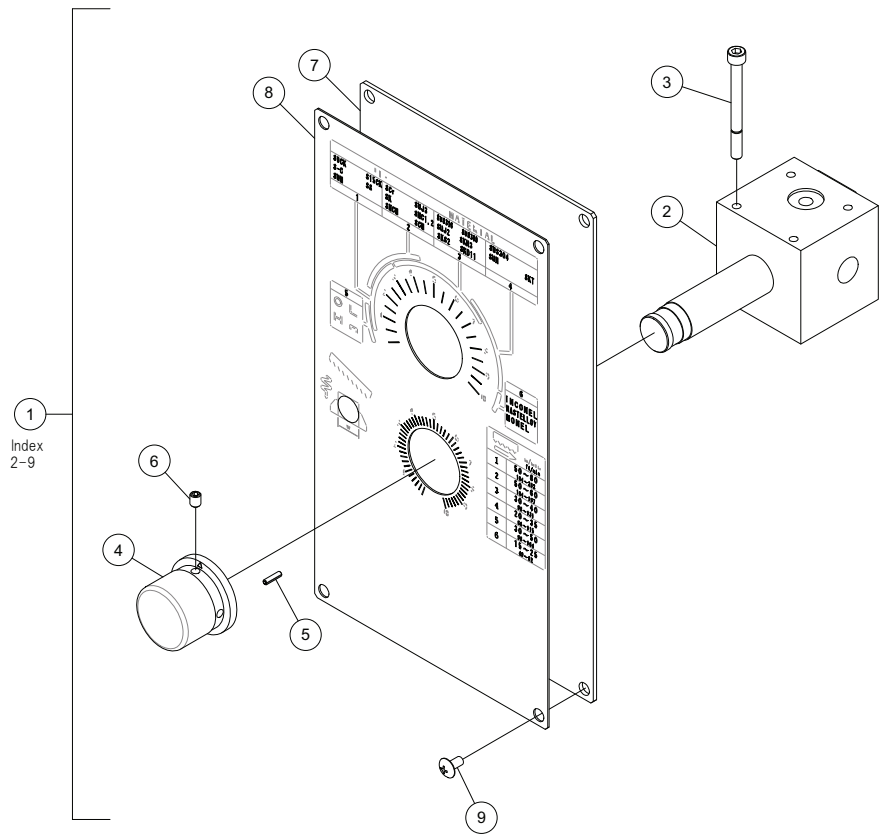

Unit No. 40
Hydraulic(7)

| Index | Code | Parts Name | Drawing No. | Type | Maker | Q'ty | Note |
|-------|----------|----------------------|-------------|--|-------|------|----------------|
| 1 | 10302099 | Flow Control Valve | SBS0131--- | RB00562---, RB00563--A, RB00564--- others | | 1 | with Index 2-9 |
| 2 | 10300640 | Flow Control Valve | RB00562--- | | | 1 | |
| 3 | 10372021 | Hex Socket Cap Screw | P330220019 | M6X65 | MOURI | 4 | |
| 4 | 10300655 | Dial | RB00563--A | | | 1 | |
| 5 | 10329646 | Spring Pin | P337030012 | 3X12AW | JIS | 1 | |
| 6 | 10322120 | Socket Set Screw | P330590018 | M6X8(Dimple Type) | JIS | 2 | |
| 7 | 10300656 | Valve Setting Plate | RB00564--- | | | 1 | |
| 8 | 10300657 | Name Plate | RB00565--- | | | 1 | |
| 9 | 10322131 | Truss Head Screw | P334130008 | M5X10 | JIS | 4 | |

Unit No. 41
 Hydraulic(8) <Bellows>

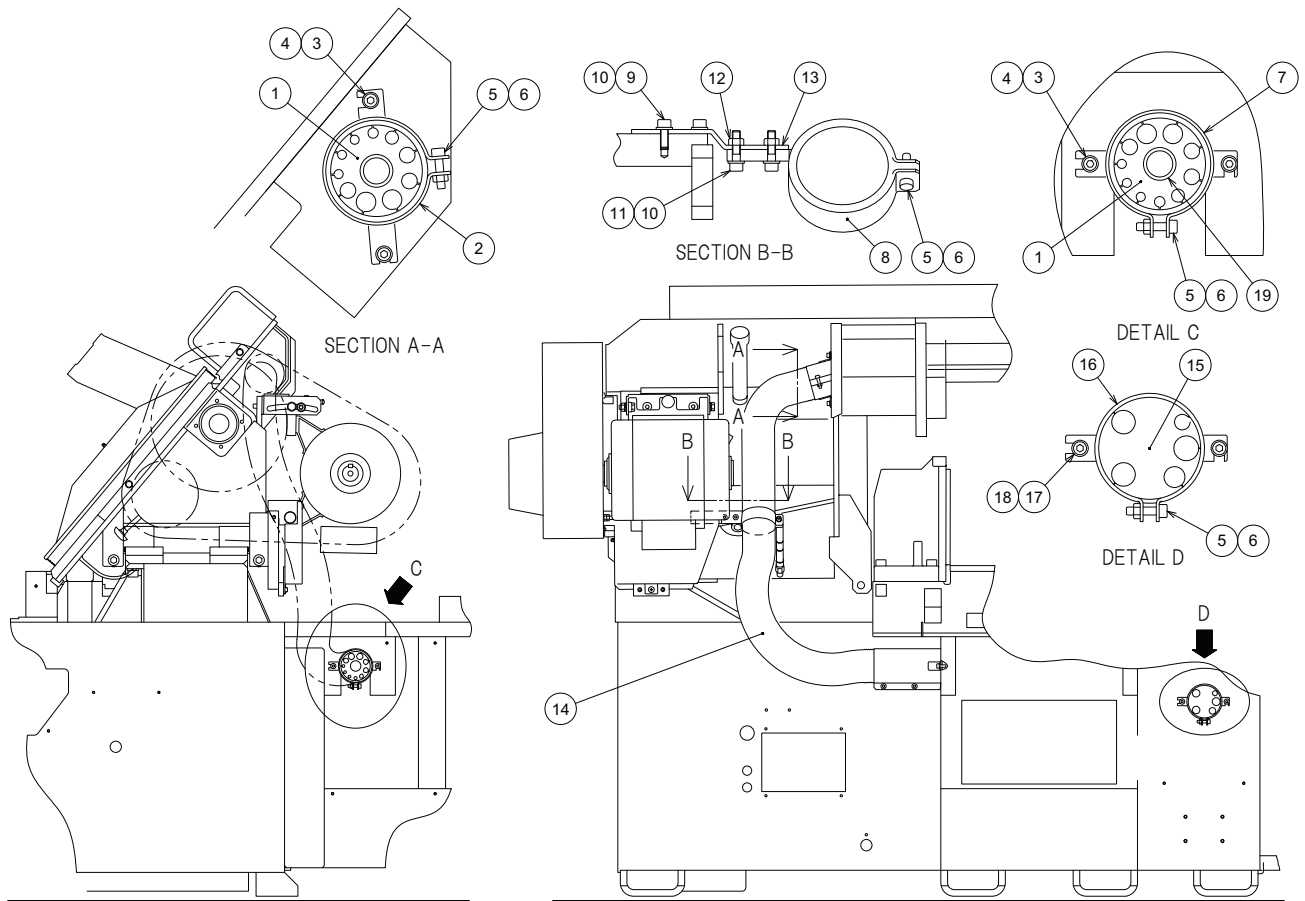

1278792--A

Unit No. 41
Hydraulic(8)

| Index | Code | Parts Name | Drawing No. | Type | Maker | Q'ty | Note |
|-------|----------|----------------------|-------------|-----------|-------|------|------|
| 1 | 10578750 | Hose Retainer | 1109084 A | | | 2 | |
| 2 | 10583661 | Bellows Support | 1230072 B | | | 1 | |
| 3 | 10323204 | Hex Socket Cap Screw | P330220007 | M6X16 | JIS | 4 | |
| 4 | 10321922 | Washer | P336000005 | 6(Normal) | JIS | 4 | |
| 5 | 10324622 | Hex Socket Cap Screw | P330220011 | M6X25 | | 4 | |
| 6 | 10589225 | Nut | P332000004 | M6 | JIS | 4 | |
| 7 | 10311165 | Bellows Support A | 1230074 | | | 1 | |
| 8 | 10583662 | Pipe Fitting | 1230314 A | | | 1 | |
| 9 | 10323204 | Hex Socket Cap Screw | P330220007 | M6X16 | JIS | 2 | |
| 10 | 10321922 | Washer | P336000005 | 6(Normal) | JIS | 4 | |
| 11 | 10324622 | Hex Socket Cap Screw | P330220011 | M6X25 | | 2 | |
| 12 | 10589225 | Nut | P332000004 | M6 | JIS | 2 | |
| 13 | 10419340 | Pipe Fitting Bracket | 1238760 A | | | 1 | |
| 14 | 10583663 | Bellows Hose | 1074443 B | | | 1 | |
| 15 | 10379543 | Hose Retainer 1 | 1238243 B | | | 1 | |
| 16 | 10583664 | Bellows Support | 1230073 | | | 1 | |
| 17 | 10323204 | Hex Socket Cap Screw | P330220007 | M6X16 | JIS | 2 | |
| 18 | 10321922 | Washer | P336000005 | 6(Normal) | JIS | 2 | |
| 19 | 10583665 | Collar | 1440029 | | | 2 | |

Unit No. 42
 Hydraulic(9)-1/2 <Oil Cleaner>

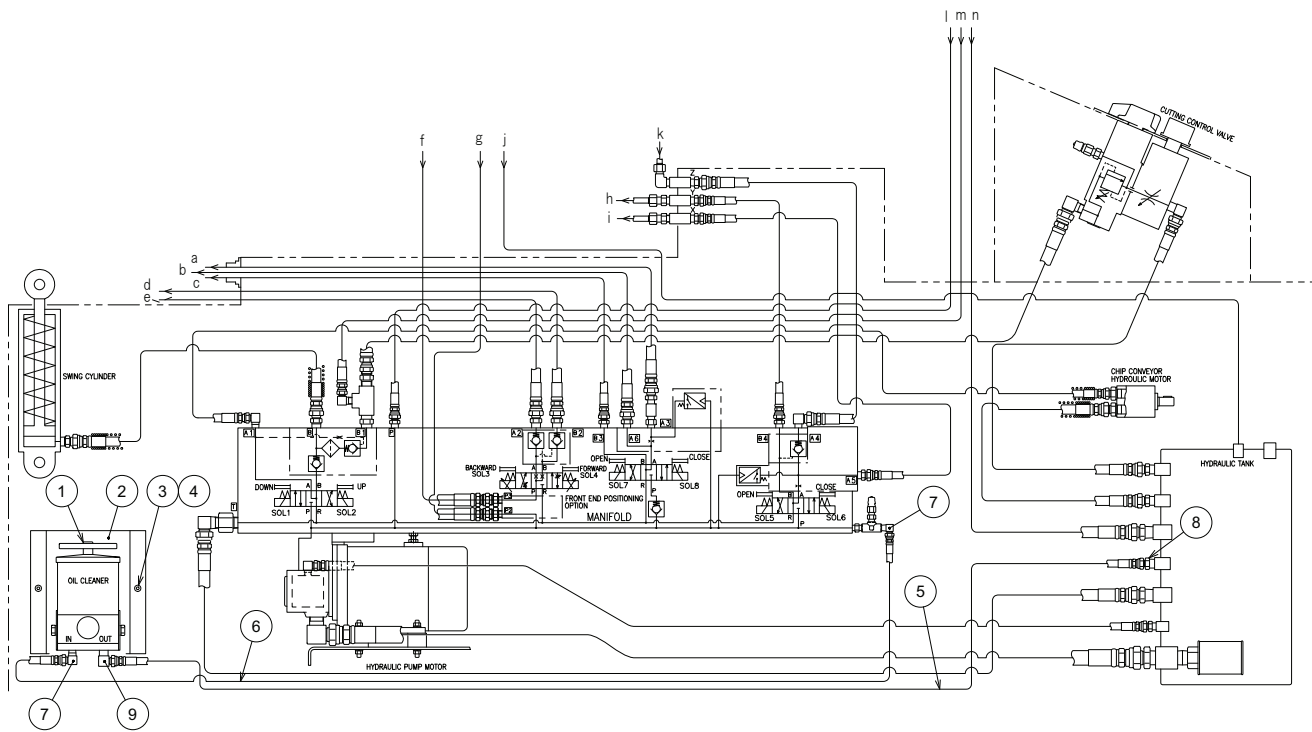

1278887--A
 (1278791--C)

Unit No. 42
 Hydraulic(9)-2/2 <Oil Cleaner>

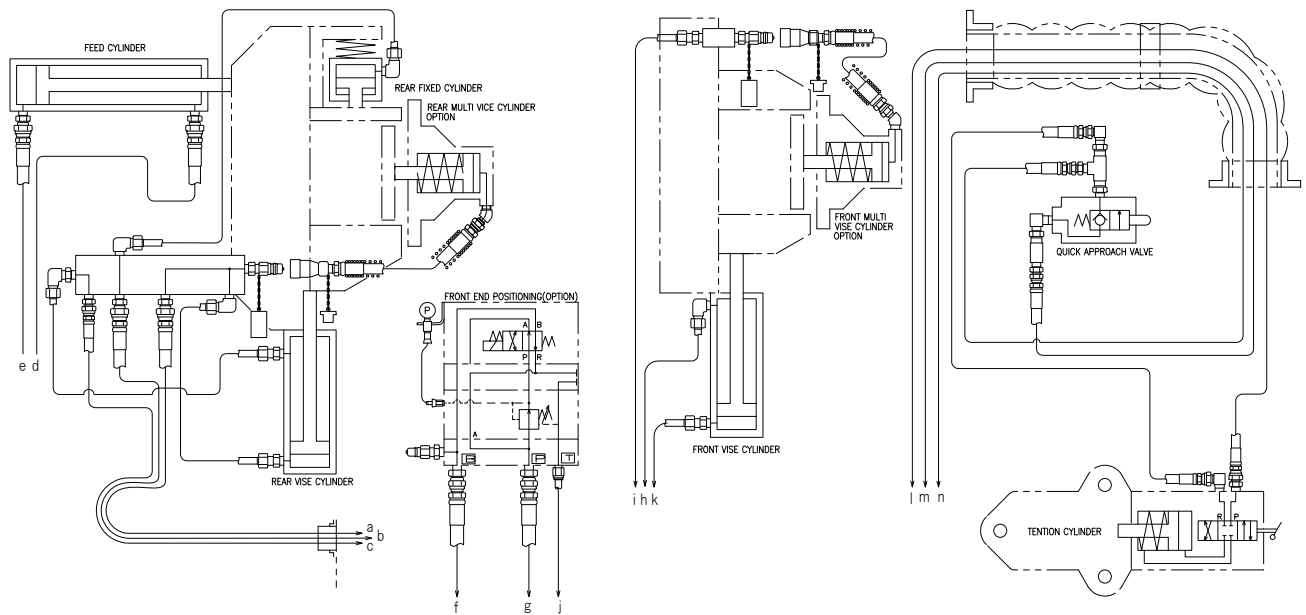

1278887--A
 (1278791--C)

Unit No. 42
Hydraulic(9)

| Index | Code | Parts Name | Drawing No. | Type | Maker | Q'ty | Note |
|-------|----------|----------------------|-------------|-------------|-------|------|------|
| 1 | 10301628 | Oil Cleaner | RB00546--- | | | 1 | |
| 2 | 10379539 | Cover | 1238324 | | | 1 | |
| 3 | 10323201 | Hex Socket Cap Screw | P330220004 | M6X12 | JIS | 2 | |
| 4 | 10321922 | Washer | P336000005 | 6(Normal) | JIS | 2 | |
| 5 | 10379537 | Hose A | 1238285 | | | 1 | |
| 6 | 10379538 | Hose B | 1238286 | | | 1 | |
| 7 | 10300603 | Elbow | RB0054021A | PT1/4-PF1/4 | | 2 | |
| 8 | 10300599 | Male-Male Adapter | RB0054015A | PT3/8-PF1/4 | | 1 | |
| 9 | 10301821 | Elbow | RB0198910- | PT3/8-PF1/4 | | 1 | |

Unit No. 43
 Swing Cylinder

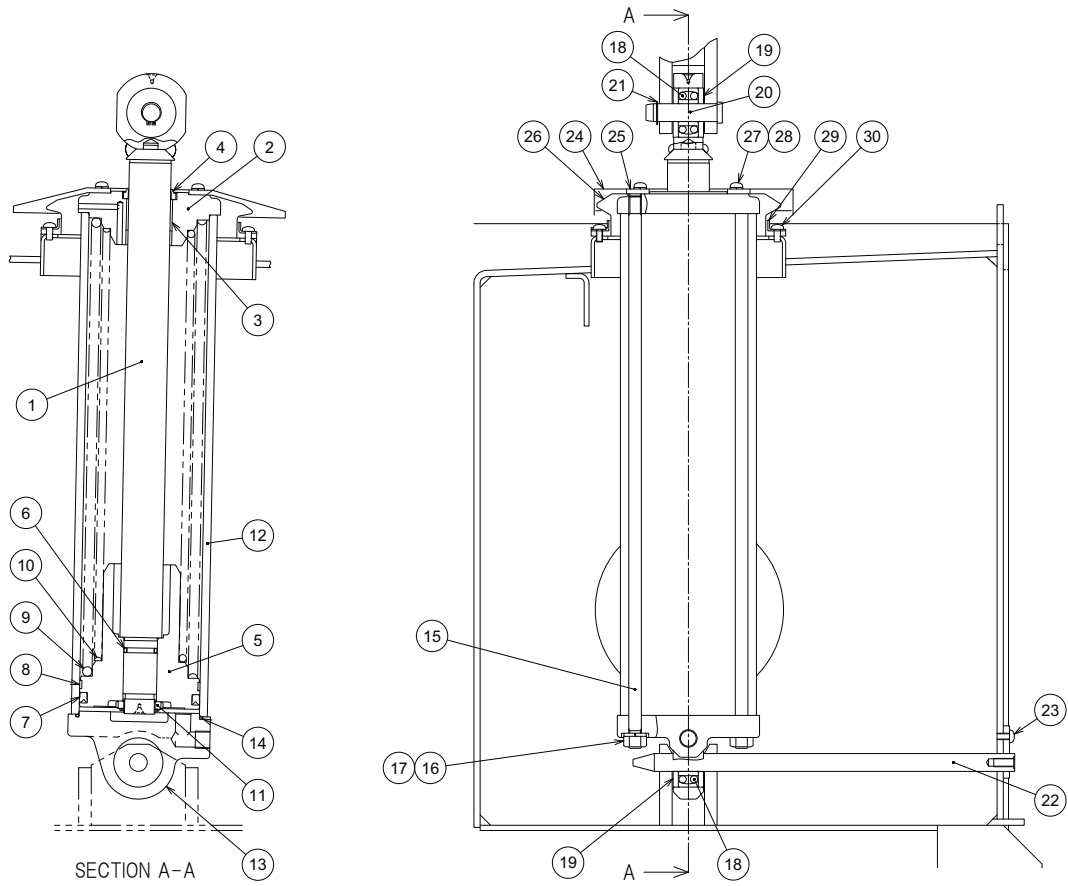

1278794---

Unit No. 43
Swing Cylinder

| Index | Code | Parts Name | Drawing No. | Type | Maker | Q'ty | Note |
|-------|----------|---------------------------|-------------|----------|---------------|------|------|
| 1 | 10378263 | Piston Rod | 1238338 A | | | 1 | |
| 2 | 10329819 | Upper Cylinder Cap | 1230422 C | | | 1 | |
| 3 | 10583666 | Plain Bearing | P407003192 | DUB4030 | DAIDO METAL | 1 | |
| 4 | 10330117 | Wiper Ring | P590312008 | DKI-40 | NOK | 1 | |
| 5 | 10378261 | Piston | 1238336 A | | | 1 | |
| 6 | 10001121 | O Ring | P590000026 | P26 | | 1 | |
| 7 | 10380559 | Piston Packing | P590403056 | SKY-100 | SAKAGAMI | 1 | |
| 8 | 10378268 | Wearing | 7922625 | | SAKAGAMI | 1 | |
| 9 | 10329827 | Sawhead Cylinder Spring 1 | 1230433 | | | 1 | |
| 10 | 10329828 | Sawhead Cylinder Spring 2 | 1230434 | | | 1 | |
| 11 | 10301294 | Lock Nut | P406168011 | FU06SC | FUJI SEIMITSU | 1 | |
| 12 | 10378262 | Cylinder | 1238337 | | | 1 | |
| 13 | 10421543 | Lower Cylinder Cap | 1230426 G | | | 1 | |
| 14 | 10330004 | O Ring | P590010019 | G115 | | 1 | |
| 15 | 10378264 | Tie Rod Bolt | 1238339 | D12X528L | | 4 | |
| 16 | 10000829 | Spring Washer | P336050008 | 12 | JIS | 4 | |
| 17 | 10589227 | Nut | P332000007 | M12 | JIS | 4 | |
| 18 | 10316429 | Ball Bearing | P400077004 | 2303 | NSK | 2 | |
| 19 | 10316506 | Bearing Retainer | 0604338 | | | 4 | |

Unit No. 43
Swing Cylinder

| Index | Code | Parts Name | Drawing No. | Type | Maker | Q'ty | Note |
|-------|----------|---------------------|-------------|--------|--------|------|------|
| 20 | 10378266 | Hinge Shaft | 1238341 | | | 1 | |
| 21 | 10316009 | Locating Snap Ring | P406108040 | STW-17 | OCHIAI | 1 | |
| 22 | 10378265 | Flange Pin | 1238340 | | | 1 | |
| 23 | 10340019 | Truss Head Screw | P334130012 | M6X12 | JIS | 1 | |
| 24 | 10378267 | Cylinder Cover | 1238342 | | | 1 | |
| 25 | 10419528 | Reinforcement Plate | 1280399 | | | 1 | |
| 26 | 10329841 | Rectangle Bellows | 1230430 | | | 1 | |
| 27 | 10322226 | Pan Head Screw | P334100055 | M6X12 | JIS | 4 | |
| 28 | 10310351 | Spring Washer | P336050005 | 6 | JIS | 4 | |
| 29 | 10329843 | Bellows Support | 1230431 A | | | 1 | |
| 30 | 10322226 | Pan Head Screw | P334100055 | M6X12 | JIS | 8 | |

Unit No. 44
Wire Brush-1/2

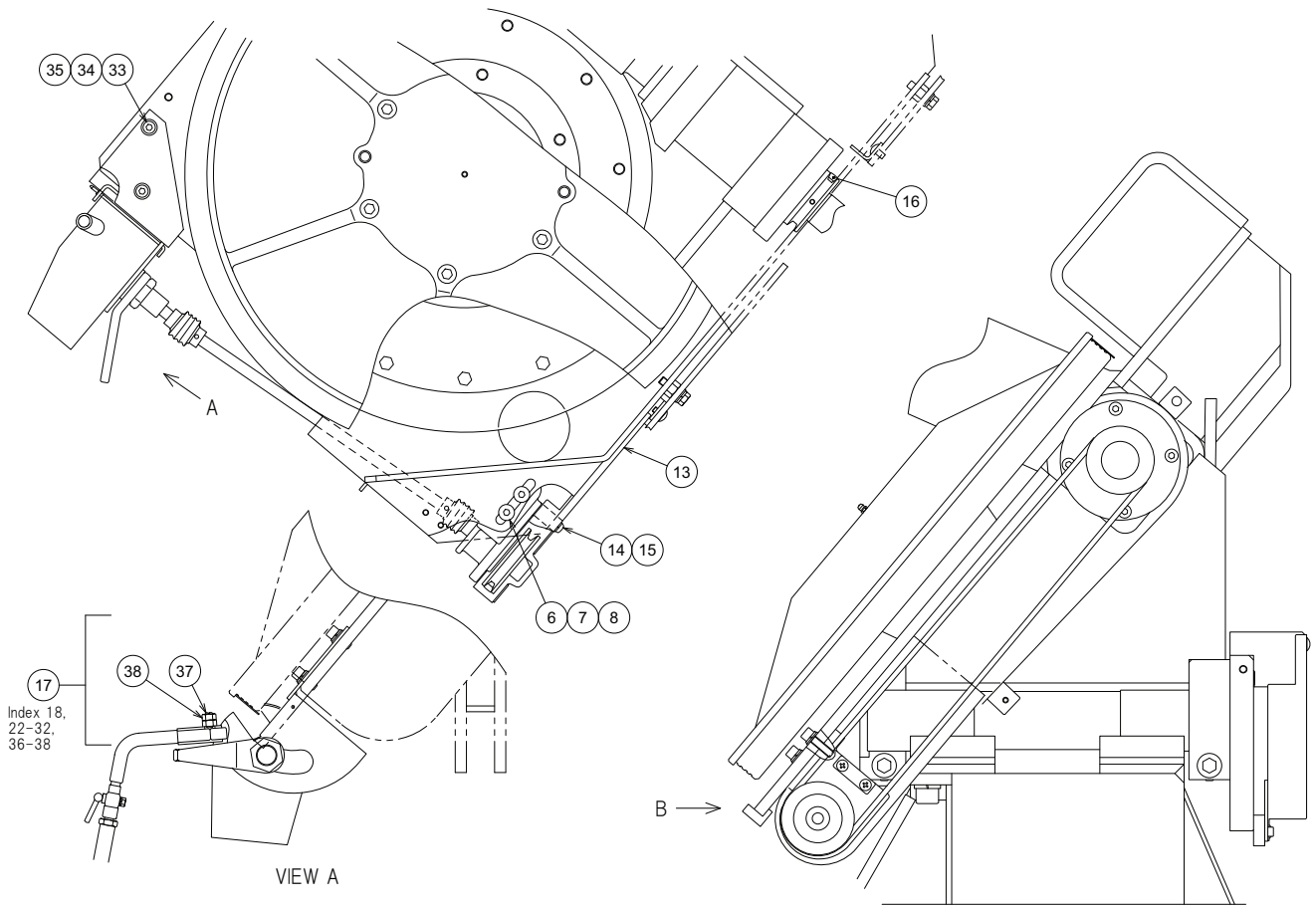

1278740--A

Unit No. 44
Wire Brush-2/2

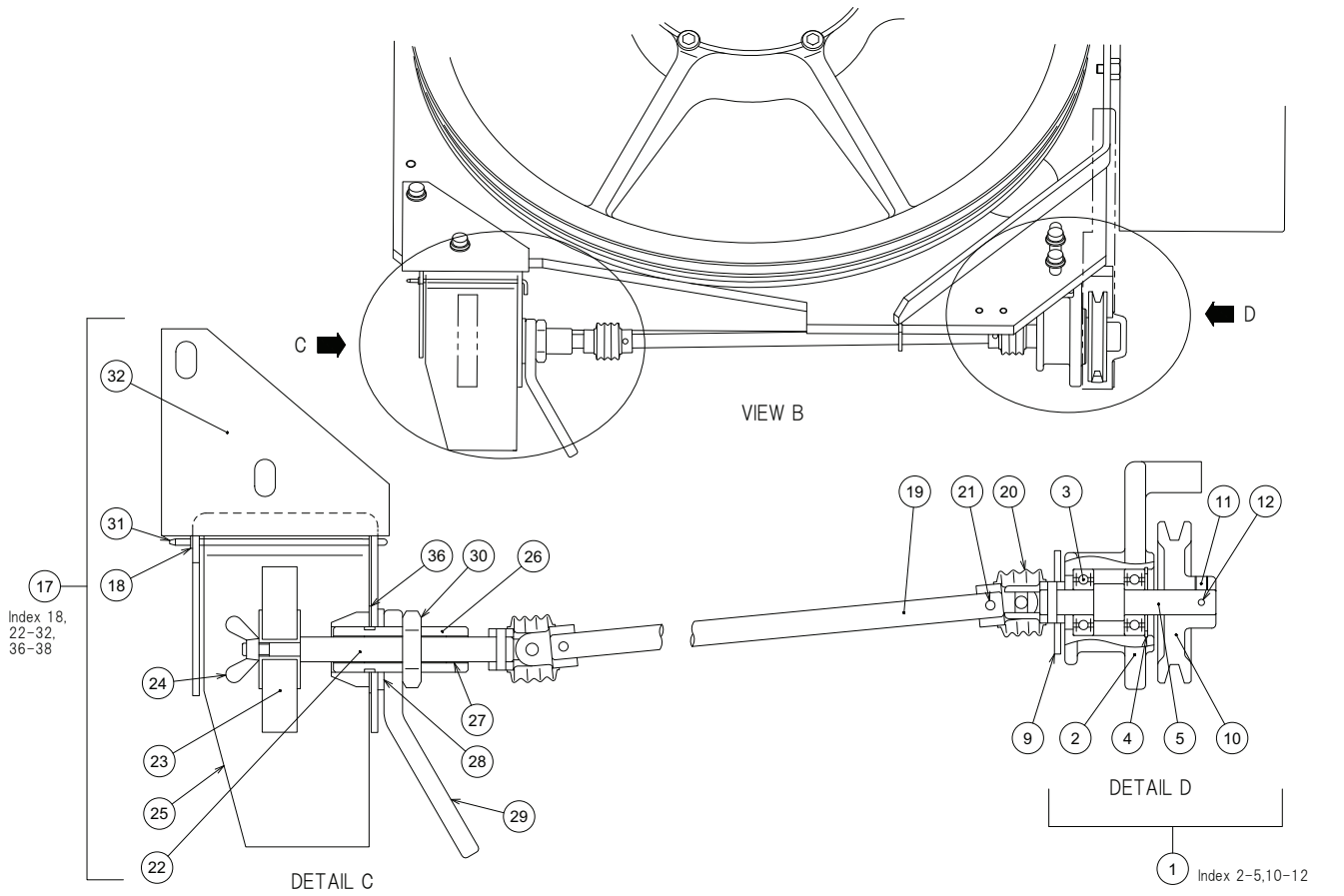

Index 18,
22-32,
36-38

Index 2-5,10-12

1278740--A

Unit No. 44
Wire Brush

| Index | Code | Parts Name | Drawing No. | Type | Maker | Q'ty | Note |
|-------|----------|--------------------------|-------------|--------------------------------------|---------------|------|---------------------------|
| 1 | 10302100 | Pulley Bracket ASSY | SBS0132--- | 1230519 B, P400010760 others | | 1 | with Index 2-5,10-12 |
| 2 | 10583667 | Bearing Bracket | 1230519 B | | | 1 | |
| 3 | 10335427 | Deep Groove Ball Bearing | P400010760 | 6201DDU | NSK(equality) | 2 | |
| 4 | 10314126 | Locating Snap Ring | P406108010 | RTW-32 | OCHIAI | 1 | |
| 5 | 10581718 | Pulley Shaft | 0604555 C | | | 1 | |
| 6 | 10330101 | Hex Socket Cap Screw | P330230008 | M8X30 | | 2 | |
| 7 | 10321923 | Washer | P336000006 | 8(Normal) | JIS | 2 | |
| 8 | 10001521 | Spring Washer | P336050006 | 8 | JIS | 2 | |
| 9 | 10301143 | Seal Rubber | 1105591 B | | | 1 | |
| 10 | 10301142 | Brush Pulley | 0604554 A | | | 1 | |
| 11 | 10322120 | Socket Set Screw | P330590018 | M6X8(Dimple Type) | JIS | 1 | |
| 12 | 10372134 | Spring Pin | P337030043 | 5X25AW | JIS | 1 | |
| 13 | 10583668 | Pulley Cover | 1230726 C | | | 1 | |
| 14 | 10322226 | Pan Head Screw | P334100055 | M6X12 | JIS | 2 | |
| 15 | 10310351 | Spring Washer | P336050005 | 6 | JIS | 2 | |
| 16 | 10380583 | V-belt | P223000016 | M48 | | 1 | |
| 17 | 10302101 | Brush Cover ASSY | SBS0133-- | 1230516 A, RB00609--, 1238399 others | | 1 | with Index 18,22-32,36-38 |
| 18 | 10380568 | Push Nut | QZZ036537 | D3for shaft | MOURI | 1 | |
| 19 | 10314033 | Shaft | 1230517 | | | 1 | |

Unit No. 44
Wire Brush

| Index | Code | Parts Name | Drawing No. | Type | Maker | Q'ty | Note |
|-------|----------|----------------------|-------------|--------------------|-------------|------|------|
| 20 | 10583669 | Universal Joint | 7720525 | | KYOWA | 2 | |
| 21 | 10356502 | Spring Pin | P337030041 | 5X20AW | JIS | 4 | |
| 22 | 10314108 | Brush Shaft | 1230516 A | | | 1 | |
| 23 | 10300687 | Wire Brush | RB00609--- | | | 1 | |
| 24 | 10583670 | Wing Nut | P338030012 | M6(Type-1A) | JIS | 1 | |
| 25 | 10376370 | Brush Cover | 1238399 | | | 1 | |
| 26 | 10314306 | Brush Shaft Support | 1230512 B | | | 1 | |
| 27 | 10581022 | Plain Bearing | P407003148 | DUB1215 | DAIDO METAL | 2 | |
| 28 | 10380584 | Washer | P336000077 | 22(Polished Round) | JIS | 1 | |
| 29 | 10314315 | Lock Lever | 1230513 B | | | 1 | |
| 30 | 10335530 | Nut M22X1.5 | 1230520 | | | 1 | |
| 31 | 10335246 | Cover Hinge Pin | 1230515 A | | | 1 | |
| 32 | 10583671 | Brush Bracket | 1230728 A | | | 1 | |
| 33 | 10322202 | Hex Socket Cap Screw | P330230006 | M8X20 | | 2 | |
| 34 | 10321923 | Washer | P336000006 | 8(Normal) | JIS | 2 | |
| 35 | 10001521 | Spring Washer | P336050006 | 8 | JIS | 2 | |
| 36 | 10380588 | Bearing Ring | P406127021 | FTRA-2542 | NSK | 1 | |
| 37 | 10583672 | Ball Plunger | P338116011 | BSR8X30 | IMAO Mfg | 1 | |
| 38 | 10589226 | Nut | P332000005 | M8 | JIS | 1 | |

Unit No. 45
Cutting Fluid(1) <Coolant Pump>

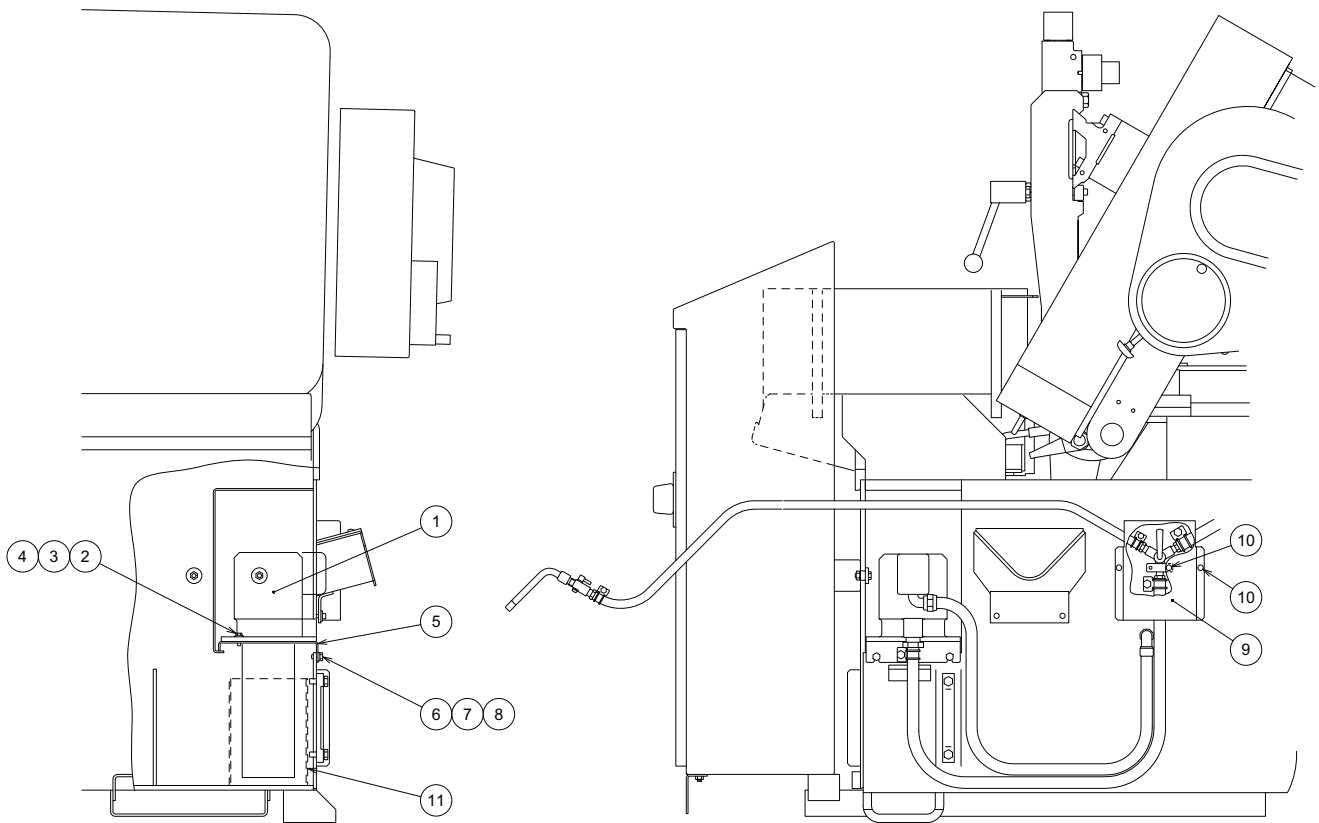

Unit No. 45
Cutting Fluid(1)

| Index | Code | Parts Name | Drawing No. | Type | Maker | Q'ty | Note |
|-------|----------|--------------------|-------------|--------------|-------|------|------|
| 1 | 10301487 | Coolant Pump | RB02051--A | DB-40A(180W) | | 1 | |
| 2 | 10371906 | Bolt | P330020006 | M6X16 | JIS | 2 | |
| 3 | 10321923 | Washer | P336000006 | 8(Normal) | JIS | 2 | |
| 4 | 10310351 | Spring Washer | P336050005 | 6 | JIS | 2 | |
| 5 | 10301488 | Motor Base | RB02052--A | | | 1 | |
| 6 | 10325826 | Bolt | P330030006 | M8X20 | | 2 | |
| 7 | 10321923 | Washer | P336000006 | 8(Normal) | JIS | 2 | |
| 8 | 10001521 | Spring Washer | P336050006 | 8 | JIS | 2 | |
| 9 | 10583674 | Cock Setting Plate | 1230550 C | | | 1 | |
| 10 | 10322226 | Pan Head Screw | P334100055 | M6X12 | JIS | 4 | |
| 11 | 10360954 | Bucket | 1295265 B | | | 1 | |

Unit No. 46
Cutting Fluid(2) <Power Source Voltage:230/460V>

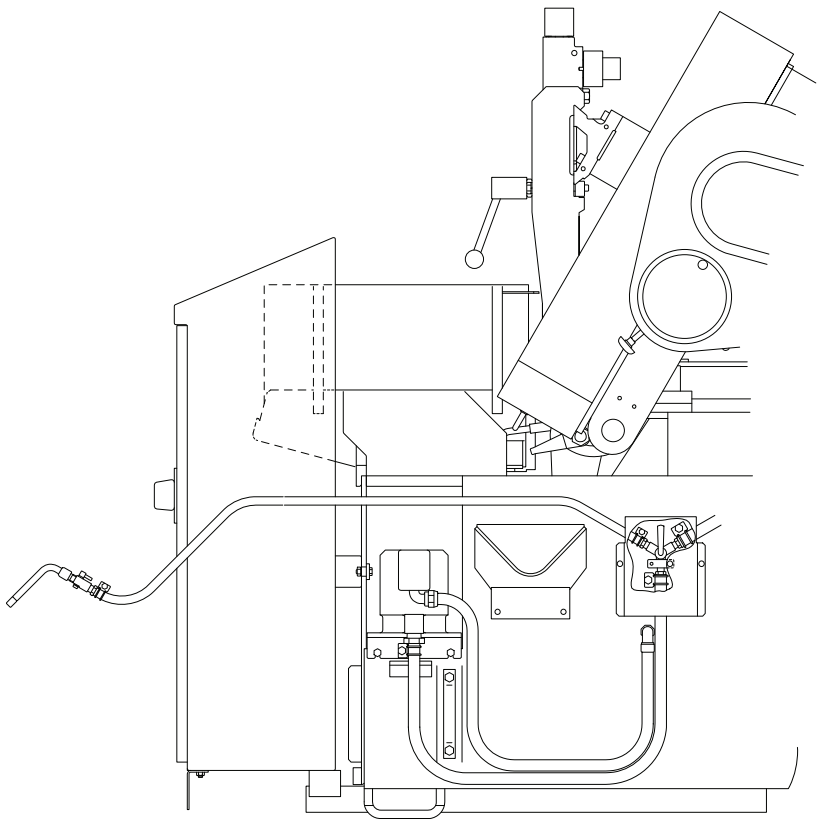
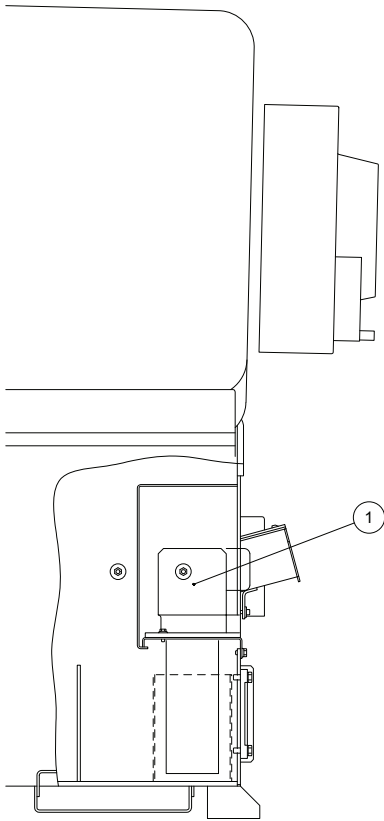

RB02428---
(1278796--A)

Unit No. 46
Cutting Fluid(2)

| Index | Code | Parts Name | Drawing No. | Type | Maker | Q'ty | Note |
|-------|----------|-----------------|-------------|---------------------|-------|------|------|
| 1 | 10301517 | Coolant Pump US | RB02428--- | 180W 230/460V(60Hz) | | 1 | |

Unit No. 47
Cutting Fluid(3) <Power Source Voltage:400V>

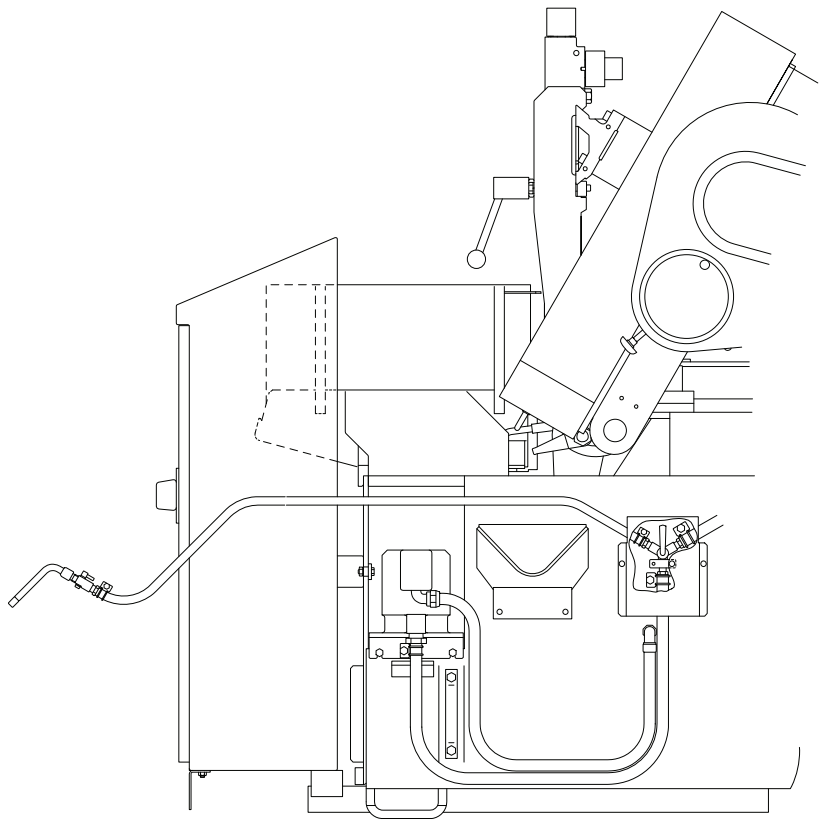
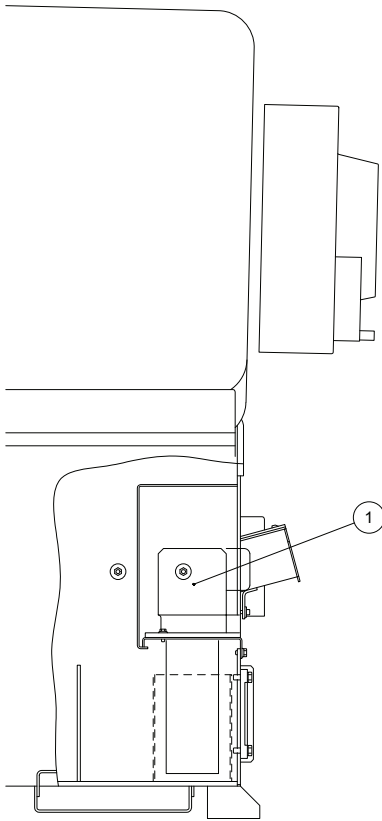

Unit No. 47

Cutting Fluid(3)

| Index | Code | Parts Name | Drawing No. | Type | Maker | Q'ty | Note |
|-------|----------|-------------------|-------------|-----------------|-------|------|------|
| 1 | 10301525 | Coolant Pump 400V | RB02478--- | 180W 400V(50Hz) | | 1 | |

Unit No. 48
Cutting Fluid(4) <Piping>

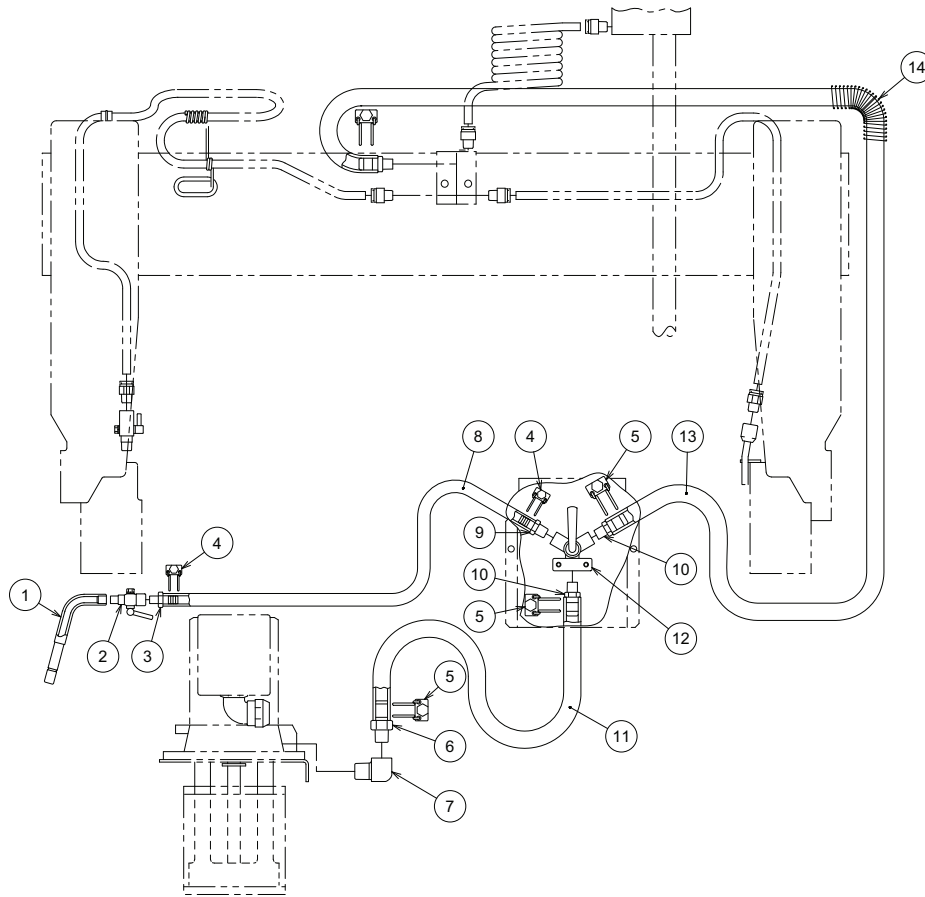

1278797--C

Unit No. 48
Cutting Fluid(4)

| Index | Code | Parts Name | Drawing No. | Type | Maker | Q'ty | Note |
|-------|----------|----------------------|-------------|-----------------|-------------|------|------|
| 1 | 10382813 | Nozzle | 1279090 | | | 1 | |
| 2 | 10583681 | P-cock | 124469717B | | | 1 | |
| 3 | 10583680 | Vinyl Hose Connector | 124469716 | | | 1 | |
| 4 | 10380357 | Hose Band | P381008029 | AK-1016 | SUGITAVALVE | 2 | |
| 5 | 10380603 | Hose Band | P381008028 | AK-1022 | SUGITAVALVE | 3 | |
| 6 | 10301325 | Vinyl Hose Connector | RB0062705- | | | 1 | |
| 7 | 10301326 | Elbow | RB0062706- | PT1/2-PF1/2 | | 1 | |
| 8 | 10301372 | Blade Hose | RB0169014A | | | 1 | |
| 9 | 10205212 | Vinyl Hose Connector | 0800087 A | | | 1 | |
| 10 | 10380604 | Joint | P589420011 | PT1/4-D=16-BSBM | | 2 | |
| 11 | 10301371 | Blade Hose | RB0169013A | | | 1 | |
| 12 | 10205114 | 3-way Cock | 0604593 A | | YBSC2 | 1 | |
| 13 | 10301370 | Blade Hose | RB0169012A | | | 1 | |
| 14 | 10301180 | Hose Guard | 1244713--A | | | 1 | |

Unit No. 49
Cutting Fluid(5) <Saw Blade Guide Piping>

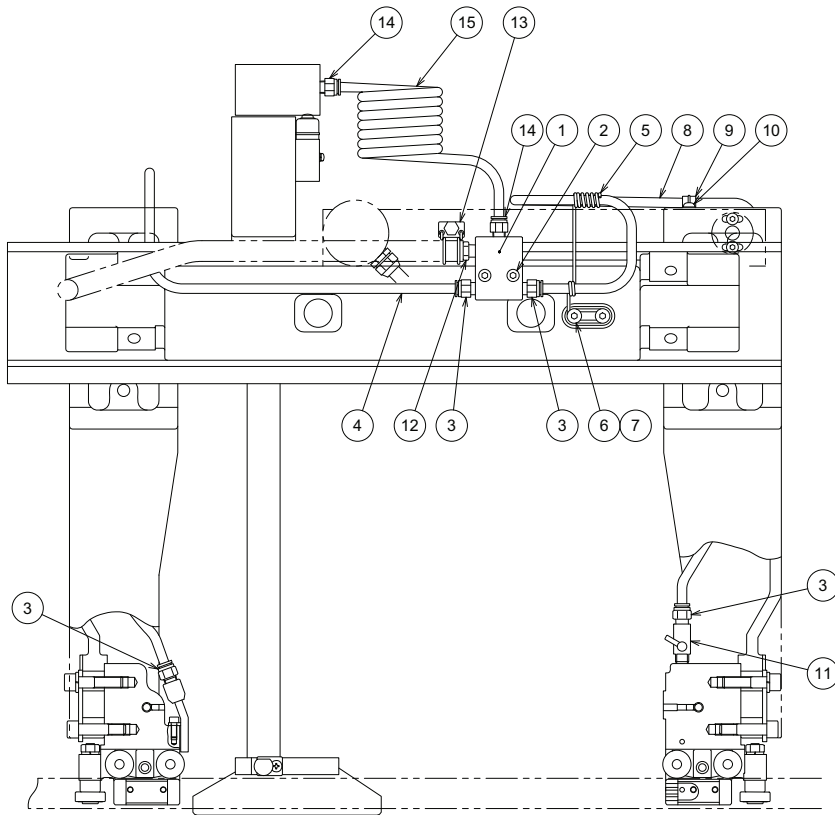

1278798--A

Unit No. 49
Cutting Fluid(5)

| Index | Code | Parts Name | Drawing No. | Type | Maker | Q'ty | Note |
|-------|----------|----------------------|-------------|-----------------|--------------|------|------|
| 1 | 10378333 | Piping Block | 1238423 | | | 1 | |
| 2 | 10323207 | Hex Socket Cap Screw | P330230010 | M8X40 | | 2 | |
| 3 | 10583676 | One Touch Fitting | 124469715 | | | 4 | |
| 4 | 10301321 | Nylon Flexible Tube | QZZ036538 | (99048360)N5-4 | NITTA MOORE | 1 | |
| 5 | 10378332 | Hose Support | 1238422 | | | 1 | |
| 6 | 10322202 | Hex Socket Cap Screw | P330230006 | M8X20 | | 2 | |
| 7 | 10321923 | Washer | P336000006 | 8(Normal) | JIS | 2 | |
| 8 | 10380597 | Cutting Fluid Tube | 1238421 | | | 1 | |
| 9 | 10329206 | Saddle for Conduit | P381017001 | CH-6 | DAIWA DENGYO | 1 | |
| 10 | 10322226 | Pan Head Screw | P334100055 | M6X12 | JIS | 1 | |
| 11 | 10583675 | P-cock | 124469711 | | | 1 | |
| 12 | 10380604 | Joint | P589420011 | PT1/4-D=16-BSBM | | 1 | |
| 13 | 10380603 | Hose Band | P381008028 | AK-1022 | SUGITAVALVE | 1 | |
| 14 | 10583676 | One Touch Fitting | 124469715 | | | 2 | |
| 15 | 10378331 | Coil Tube | 1238420 | | | 1 | |

Unit No. 50
Work Feeding Unit-1/2

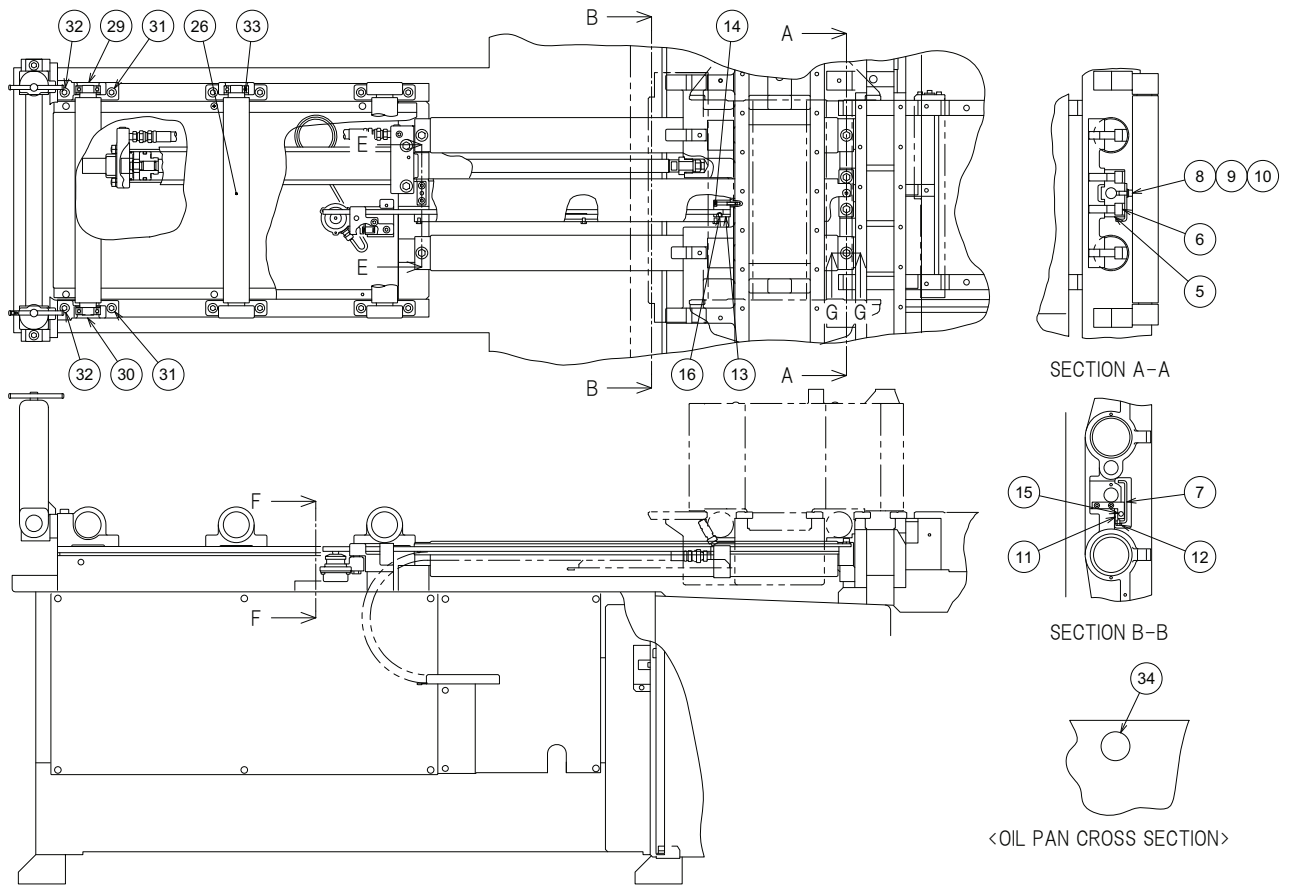

1278800--A

Unit No. 50
Work Feeding Unit-2/2

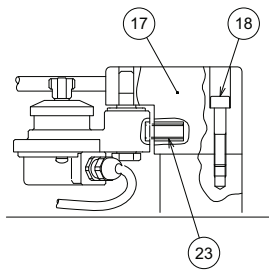

VIEW C

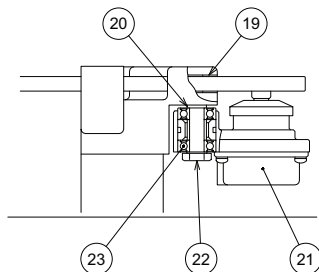

VIEW D

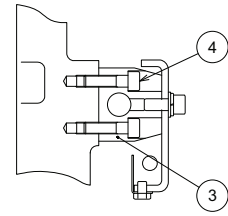

SECTION E-E

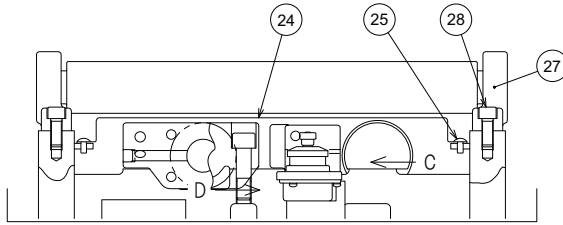

SECTION F-F

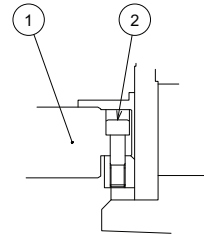

SECTION G-G

Unit No. 50

Work Feeding Unit

| Index | Code | Parts Name | Drawing No. | Type | Maker | Q'ty | Note |
|-------|----------|----------------------|-------------|-------------------|-------------|------|------|
| 1 | 10301489 | Guide Shaft | RB02081--A | | | 2 | |
| 2 | 10583160 | Reamer Bolt | 1230007 B | | | 4 | |
| 3 | 10331626 | Screw Supporter (R) | 1230580 | | | 1 | |
| 4 | 10330101 | Hex Socket Cap Screw | P330230008 | M8X30 | | 2 | |
| 5 | 10379546 | Screw Supporter (F) | 1230581 B | | | 1 | |
| 6 | 10386453 | Hex Socket Cap Screw | P330260035 | M16X55 | | 2 | |
| 7 | 10583786 | Rack Cover (U) | 1230615 B | | | 1 | |
| 8 | 10322202 | Hex Socket Cap Screw | P330230006 | M8X20 | | 2 | |
| 9 | 10321923 | Washer | P336000006 | 8(Normal) | JIS | 2 | |
| 10 | 10001521 | Spring Washer | P336050006 | 8 | JIS | 2 | |
| 11 | 10583787 | Rack Cover B | 1230616 | | | 1 | |
| 12 | 10380925 | Bolt | P330020001 | M6X8 | JIS | 3 | |
| 13 | 10379549 | Rack Bracket | 1238462 A | | | 1 | |
| 14 | 10326115 | Hex Socket Cap Screw | P330220014 | M6X40 | | 2 | |
| 15 | 10583788 | CP-Rack | 1230611 A | | | 1 | |
| 16 | 10322120 | Socket Set Screw | P330590018 | M6X8(Dimple Type) | JIS | 1 | |
| 17 | 10375719 | Encoder Bracket | 1282544 | | | 1 | |
| 18 | 10323207 | Hex Socket Cap Screw | P330230010 | M8X40 | | 2 | |
| 19 | 10485318 | Plain Bearing | P407003142 | DUB1010 | DAIDO METAL | 1 | |

Unit No. 50

Work Feeding Unit

| Index | Code | Parts Name | Drawing No. | Type | Maker | Q'ty | Note |
|-------|----------|--------------------------|-------------|---------|---------------|------|------|
| 20 | 10331840 | Washer | 1280512 | | | 1 | |
| 21 | 10301566 | Encoder | 7922647--- | | TAMAGAWA | 1 | |
| 22 | 10331523 | Hinge Bolt | 1280506 | | | 1 | |
| 23 | 10381788 | Spring | 1235136 | | | 1 | |
| 24 | 10583687 | Cylinder Cover | 1230688 A | | | 1 | |
| 25 | 10340019 | Truss Head Screw | P334130012 | M6X12 | JIS | 6 | |
| 26 | 10378346 | Roller | 1238451 A | | | 3 | |
| 27 | 10319140 | Roller Bracket | 1105660 B | | | 4 | |
| 28 | 10322203 | Hex Socket Cap Screw | P330250005 | M12X30 | | 8 | |
| 29 | 10331649 | Roller Bracket R,RM | 1230589 A | | | 1 | |
| 30 | 10428833 | Roller Bracket R,L | 1230590 B | | | 1 | |
| 31 | 10322203 | Hex Socket Cap Screw | P330250005 | M12X30 | | 2 | |
| 32 | 10000830 | Hex Socket Cap Screw | P330250015 | M12X80 | | 2 | |
| 33 | 10332038 | Deep Groove Ball Bearing | P400010666 | 6205ZZ | NSK(equality) | 6 | |
| 34 | 10380928 | Blind Plug | P229138031 | DP-1000 | HEIKO | 1 | |

Unit No. 51
Feed Cylinder(1)

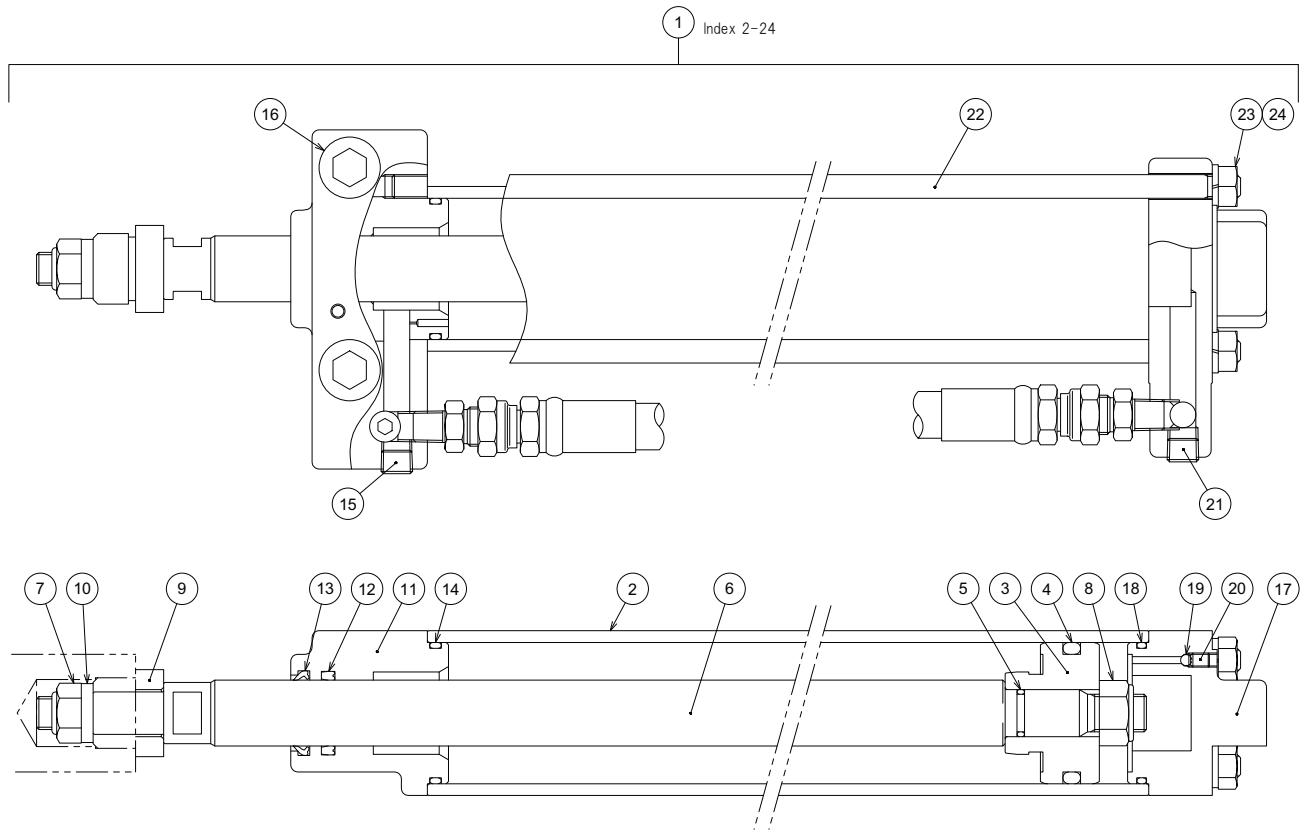

1278804---

Unit No. 51

Feed Cylinder(1)

| Index | Code | Parts Name | Drawing No. | Type | Maker | Q'ty | Note |
|-------|----------|--------------------------|-------------|--------------------------------------|---------------|------|-----------------|
| 1 | 10302102 | Feed Cylinder ASSY | SBS0134--- | 1230612 A, 1108574 B, 1238501 others | | 1 | with Index 2-24 |
| 2 | 10583694 | Cylinder | 1230612 A | | | 1 | |
| 3 | 10583695 | Piston | 1108574 B | | | 1 | |
| 4 | 10207507 | O Ring | P590000050 | P50A | | 1 | |
| 5 | 10589448 | O Ring | P590000018 | P20 | | 1 | |
| 6 | 10583696 | Piston Rod | 1230613 A | | | 1 | |
| 7 | 10382418 | Locking Nut | P332505023 | M14(Type-1) | FUJI SEIMITSU | 1 | |
| 8 | 10380665 | Locking Nut | P332505026 | M16(Type-1)-SK5 | FUJI SEIMITSU | 1 | |
| 9 | 10376389 | Bushing Nut | 1108576 C | | | 1 | |
| 10 | 10376756 | Washer | 1108577 | | | 1 | |
| 11 | 10378383 | Cylinder Cap F | 1238501 | | | 1 | |
| 12 | 10317519 | Wiper Ring | P590312003 | DKI-28 | NOK | 1 | |
| 13 | 10333005 | Piston Packing | P590403021 | SKY-28 | SAKAGAMI | 1 | |
| 14 | 10001116 | O Ring | P590010007 | G55 | | 1 | |
| 15 | 10300171 | Plug for Piping | P580208021 | PT-1/4 | | 2 | |
| 16 | 10583160 | Reamer Bolt | 1230007 B | | | 2 | |
| 17 | 10378384 | Cylinder Cap R | 1238502 | | | 1 | |
| 18 | 10001116 | O Ring | P590010007 | G55 | | 1 | |
| 19 | 10332944 | Steel Ball (for Bearing) | P406000002 | 3/16 | JIS | 1 | |

Unit No. 51

Feed Cylinder(1)

| Index | Code | Parts Name | Drawing No. | Type | Maker | Q'ty | Note |
|-------|----------|------------------|-------------|---------------|-------|------|------|
| 20 | 10326708 | Socket Set Screw | P330570062 | M6X8(Dog-end) | JIS | 1 | |
| 21 | 10300171 | Plug for Piping | P580208021 | PT-1/4 | | 2 | |
| 22 | 10583697 | Tie Rod | 1230614 A | | | 4 | |
| 23 | 10427991 | Nut | P332000006 | M10 | JIS | 4 | |
| 24 | 10001520 | Spring Washer | P336050007 | 10 | JIS | 4 | |

Unit No. 52
Feed Cylinder(2) <EU Specification Machine>

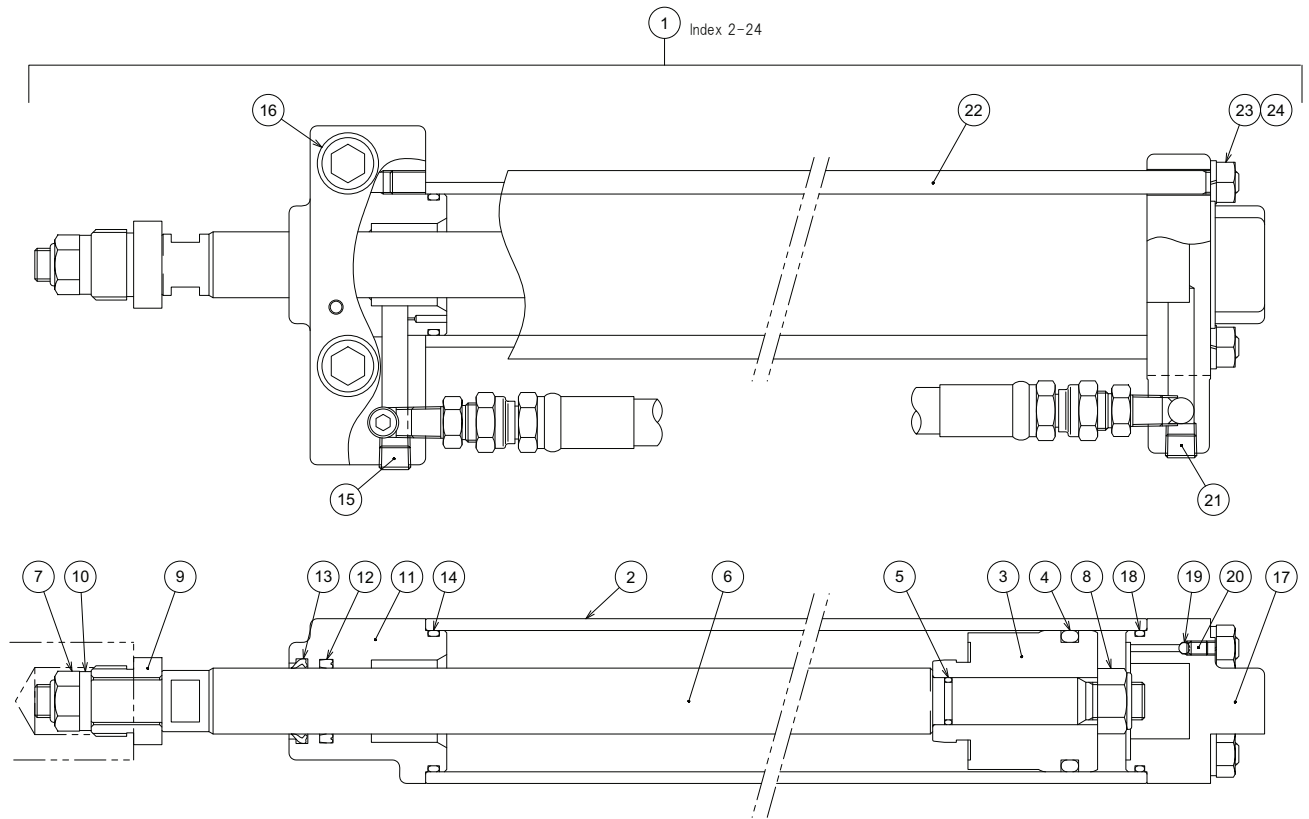

1230338A

Unit No. 52

Feed Cylinder(2)

| Index | Code | Parts Name | Drawing No. | Type | Maker | Q'ty | Note |
|-------|----------|--------------------------|-------------|--------------------------------------|---------------|------|-----------------|
| 1 | 10302106 | Feed Cylinder EU ASSY | SBS0138--- | 1230612 A, 1440907 A, 1238501 others | | 1 | with Index 2-24 |
| 2 | 10583694 | Cylinder | 1230612 A | | | 1 | |
| 3 | 10301253 | Piston | 1440907 A | | | 1 | |
| 4 | 10207507 | O Ring | P590000050 | P50A | | 1 | |
| 5 | 10589448 | O Ring | P590000018 | P20 | | 1 | |
| 6 | 10301160 | Piston Rod | 1230973 | | | 1 | |
| 7 | 10382418 | Locking Nut | P332505023 | M14(Type-1) | FUJI SEIMITSU | 1 | |
| 8 | 10380665 | Locking Nut | P332505026 | M16(Type-1)-SK5 | FUJI SEIMITSU | 1 | |
| 9 | 10376389 | Bushing Nut | 1108576 C | | | 1 | |
| 10 | 10376756 | Washer | 1108577 | | | 1 | |
| 11 | 10378383 | Cylinder Cap F | 1238501 | | | 1 | |
| 12 | 10317519 | Wiper Ring | P590312003 | DKI-28 | NOK | 1 | |
| 13 | 10333005 | Piston Packing | P590403021 | SKY-28 | SAKAGAMI | 1 | |
| 14 | 10001116 | O Ring | P590010007 | G55 | | 1 | |
| 15 | 10300171 | Plug for Piping | P580208021 | PT-1/4 | | 2 | |
| 16 | 10583160 | Reamer Bolt | 1230007 B | | | 2 | |
| 17 | 10378384 | Cylinder Cap R | 1238502 | | | 1 | |
| 18 | 10001116 | O Ring | P590010007 | G55 | | 1 | |
| 19 | 10332944 | Steel Ball (for Bearing) | P406000002 | 3/16 | JIS | 1 | |

Unit No. 52

Feed Cylinder(2)

| Index | Code | Parts Name | Drawing No. | Type | Maker | Q'ty | Note |
|-------|----------|------------------|-------------|---------------|-------|------|------|
| 20 | 10326708 | Socket Set Screw | P330570062 | M6X8(Dog-end) | JIS | 1 | |
| 21 | 10300171 | Plug for Piping | P580208021 | PT-1/4 | | 2 | |
| 22 | 10583697 | Tie Rod | 1230614 A | | | 4 | |
| 23 | 10427991 | Nut | P332000006 | M10 | JIS | 4 | |
| 24 | 10001520 | Spring Washer | P336050007 | 10 | JIS | 4 | |

Unit No. 53
Vertical Roller

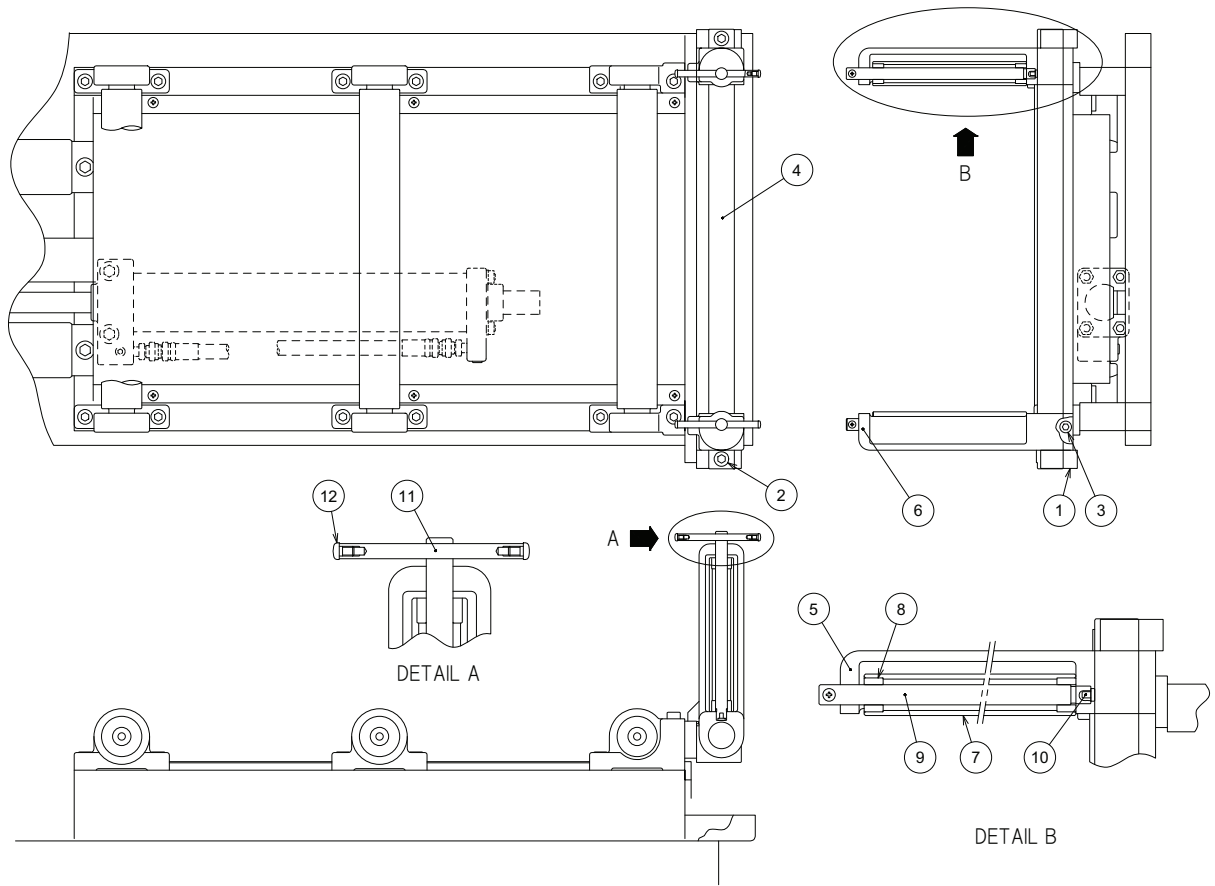

1238571--A

Unit No. 53
Vertical Roller

| Index | Code | Parts Name | Drawing No. | Type | Maker | Q'ty | Note |
|-------|----------|-------------------------|-------------|--------|-------|------|------|
| 1 | 10378565 | Support Bracket | 1238587 | | | 1 | |
| 2 | 10322203 | Hex Socket Cap Screw | P330250005 | M12X30 | | 2 | |
| 3 | 10341713 | Hex Socket Cap Screw | P330240006 | M10X20 | | 4 | |
| 4 | 10378564 | Guide Bar | 1238586 | | | 1 | |
| 5 | 10380765 | Roller Bracket Left | 1238583 A | | | 1 | |
| 6 | 10380764 | Roller Bracket Right | 1238582 A | | | 1 | |
| 7 | 10378563 | Roller | 1238585 | | | 2 | |
| 8 | 10301139 | Shaft Support | 0603310--A | | | 4 | |
| 9 | 10378562 | Vertical Roller Set Bar | 1238584 | | | 2 | |
| 10 | 10301140 | Lock Piece | 0603312--A | | | 2 | |
| 11 | 10301141 | Handle | 0603314--C | | | 2 | |
| 12 | 10325312 | Pan Head Screw | P334100054 | M6X10 | JIS | 4 | |

Unit No. 54
Rear Vise(1)-1/3

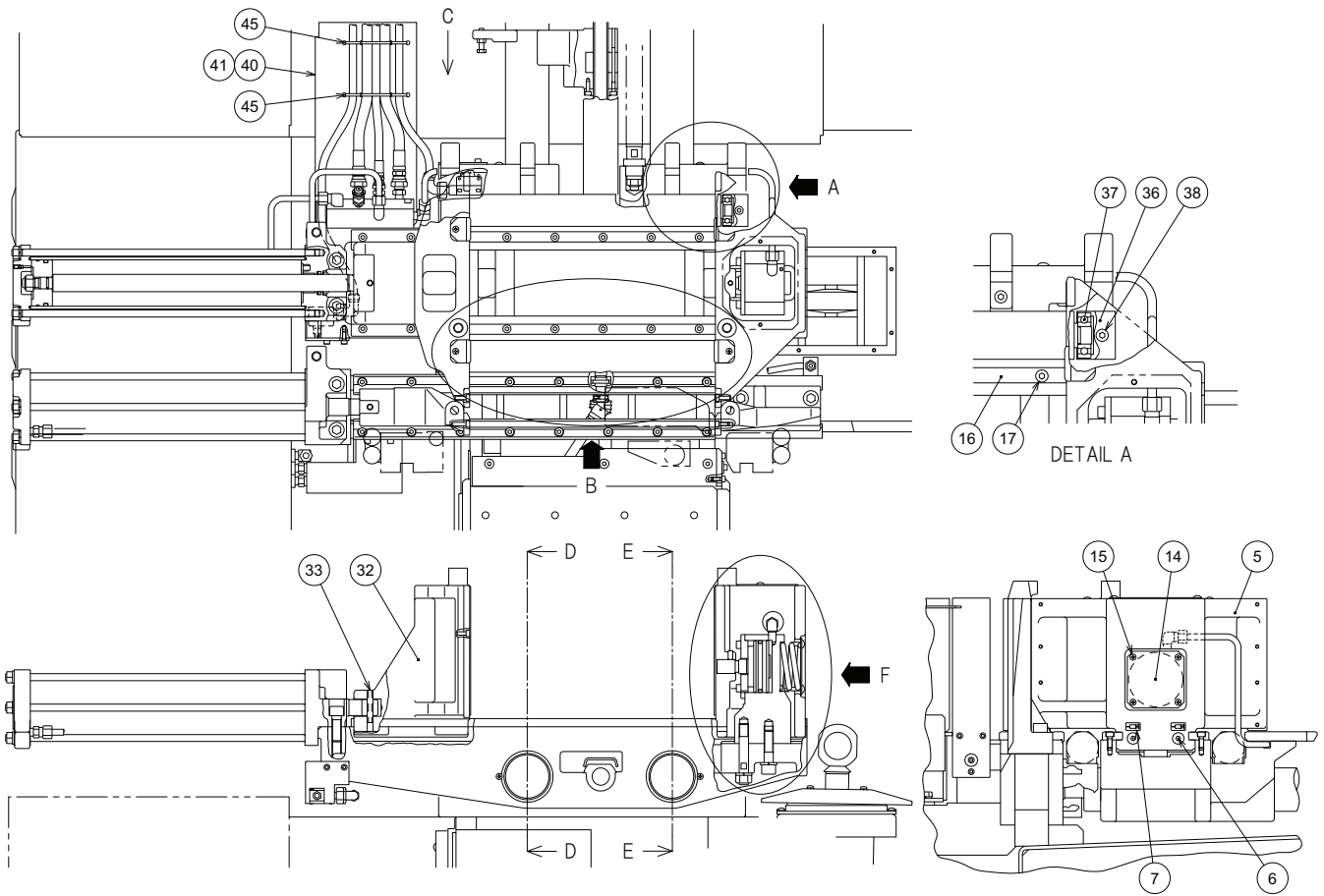

1278801--A

Unit No. 54
Rear Vise(1)-2/3

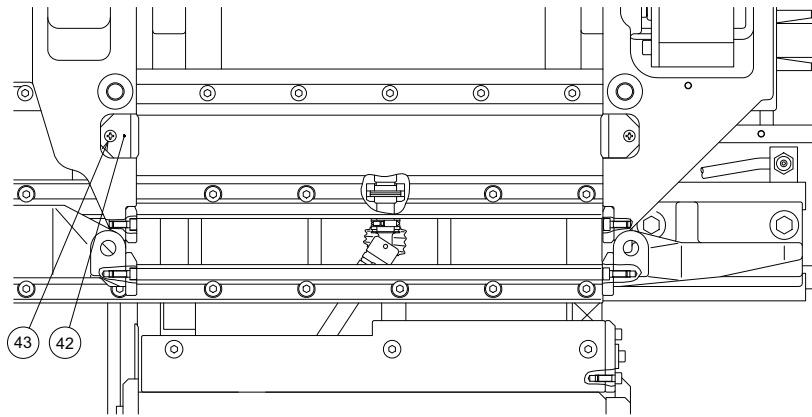

DETAIL B

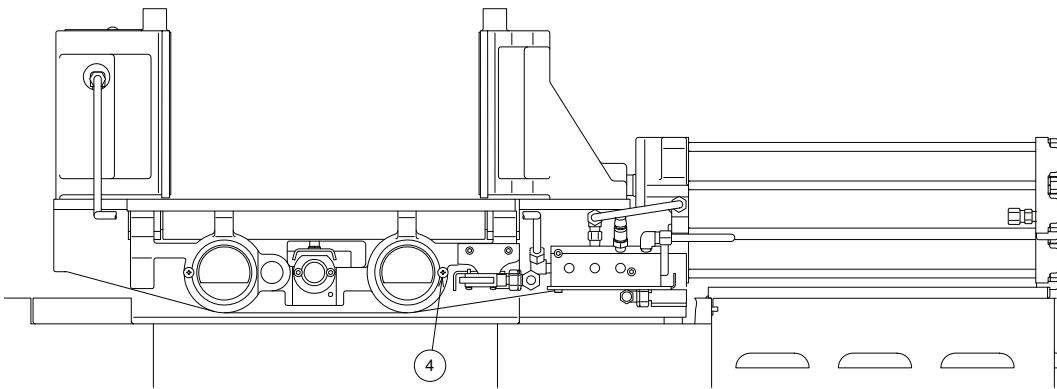

VIEW C

1278801--A

Unit No. 54
Rear Vise(1)-3/3

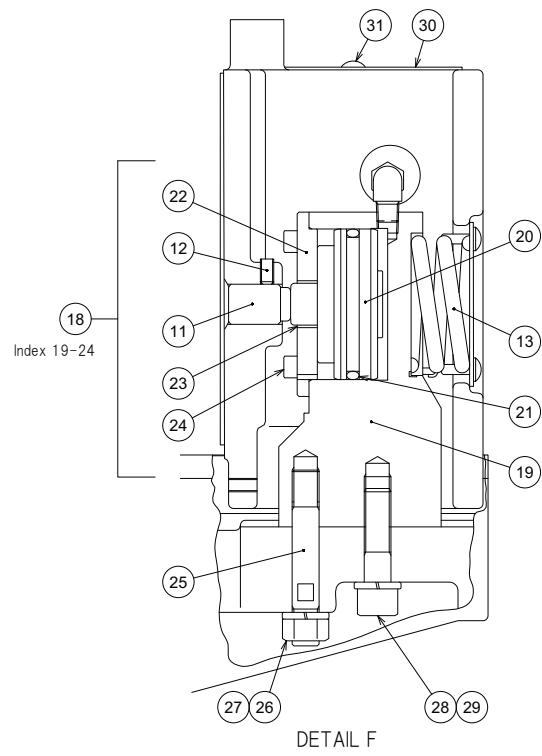
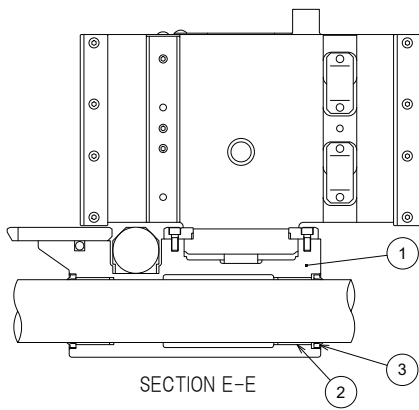
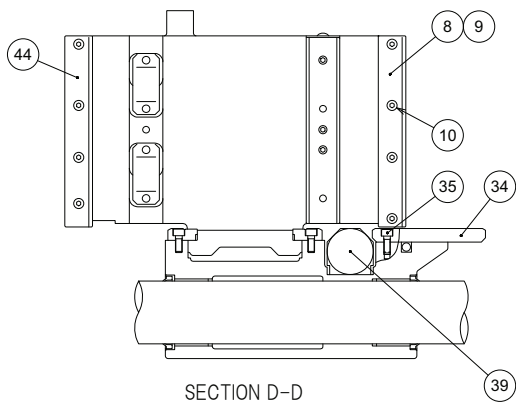

Unit No. 54
Rear Vise(1)

| Index | Code | Parts Name | Drawing No. | Type | Maker | Q'ty | Note |
|-------|----------|---|-------------|------------------------------------|----------|------|------------------|
| 1 | 10583698 | Rear Vise Bed | 1238492 E | | | 1 | |
| 2 | 10301324 | Plain Bearing | RB0054082- | SF-1 7540 | KBT | 4 | |
| 3 | 10375805 | Wiper Ring | P590313017 | SCB-75 | SAKAGAMI | 4 | |
| 4 | 10340019 | Truss Head Screw | P334130012 | M6X12 | JIS | 4 | |
| 5 | 10380650 | Rear Vise Jaw (Stationary) | 1238473 | | | 1 | |
| 6 | 10419913 | Grease Nipple | P560600002 | A-MT6X1 | JIS | 2 | |
| 7 | 10323010 | Name Plate | 0852250 | | | 2 | |
| 8 | 10378365 | Rear Vise Plate | 1238687 A | | | 3 | |
| 9 | 10378369 | Stationary Vise Shim | 1238484 | | | 1 | |
| 10 | 10312831 | Hex Socket Cap Screw | P330220006 | M6X15 | | 16 | |
| 11 | 10567020 | Pushing Screw | 1230669 A | | | 1 | |
| 12 | 10329311 | Socket Set Screw | P330590058 | M8X15(Dimple Type) | MOURI | 1 | |
| 13 | 10301157 | Spring | 1230677 A | | | 1 | |
| 14 | 10332711 | Spring Retainer | 1230670 | | | 1 | |
| 15 | 10322133 | Truss Head Screw | P334130014 | M6X20 | JIS | 4 | |
| 16 | 10301173 | Slide Plate | 1238493 B | | | 2 | |
| 17 | 10322202 | Hex Socket Cap Screw | P330230006 | M8X20 | | 20 | |
| 18 | 10302103 | Rear Vise Cylinder (Stationary Jaw Side) ASSY | SBS0135--- | 1230673, 1230674, 1230675 A others | | 1 | with Index 19-24 |
| 19 | 10316910 | Cylinder | 1230673 | | | 1 | |

Unit No. 54
Rear Vise(1)

| Index | Code | Parts Name | Drawing No. | Type | Maker | Q'ty | Note |
|-------|----------|--------------------------|-------------|---------|-------------|------|------|
| 20 | 10316917 | Stationary Vise Piston | 1230674 | | | 1 | |
| 21 | 10316808 | O Ring | P590000064 | P80 | | 1 | |
| 22 | 10332607 | Cylinder Cap | 1230675 A | | | 1 | |
| 23 | 10581365 | Plain Bearing | P407003207 | DUB2512 | DAIDO METAL | 1 | |
| 24 | 10322202 | Hex Socket Cap Screw | P330230006 | M8X20 | | 4 | |
| 25 | 10313646 | Reamer Bolt | 1230676 | | | 1 | |
| 26 | 10322218 | Spring Washer | P336050010 | 16 | JIS | 1 | |
| 27 | 10421756 | Nut | P332000009 | M16 | JIS | 1 | |
| 28 | 10332954 | Hex Socket Cap Screw | P330260036 | M16X60 | | 1 | |
| 29 | 10322153 | Conical Spring Washer | P336165005 | CDW-16H | HHK | 1 | |
| 30 | 10378370 | Cover | 1238497 | | | 1 | |
| 31 | 10340019 | Truss Head Screw | P334130012 | M6X12 | JIS | 2 | |
| 32 | 10583699 | Rear Vise Movable Jaw | 1238474 B | | | 1 | |
| 33 | 10322112 | Spring Pin | P337030096 | 10X60AW | OHKITA | 1 | |
| 34 | 10583701 | Auxiliary Plate | 1230659 A | | | 1 | |
| 35 | 10322202 | Hex Socket Cap Screw | P330230006 | M8X20 | | 2 | |
| 36 | 10376204 | Roller Bracket | 1233020 B | | | 2 | |
| 37 | 10555909 | Deep Groove Ball Bearing | P400017017 | 6304DDU | NSK | 2 | |
| 38 | 10342326 | Hex Socket Cap Screw | P330230012 | M8X50 | | 2 | |

Unit No. 54
Rear Vise(1)

| Index | Code | Parts Name | Drawing No. | Type | Maker | Q'ty | Note |
|-------|----------|----------------------|-------------|--------|----------|------|------|
| 39 | 10378048 | Roller | 1238488 A | | | 1 | |
| 40 | 10583702 | Plate | 1230679 B | | | 1 | |
| 41 | 10323201 | Hex Socket Cap Screw | P330220004 | M6X12 | JIS | 2 | |
| 42 | 10380642 | Vise Plate Cover | 1280733 A | | | 4 | |
| 43 | 10332134 | Truss Head Screw | P334130010 | M6X8 | JIS | 4 | |
| 44 | 10419350 | Rear Vise Plate 2 | 1238886 | | | 1 | |
| 45 | 10375463 | Cable Band | P381058035 | SKB-2M | KITAGAWA | 12 | |

Unit No. 55
 Rear Vise(2)-1/3 <Rear Vise for EU Spec>

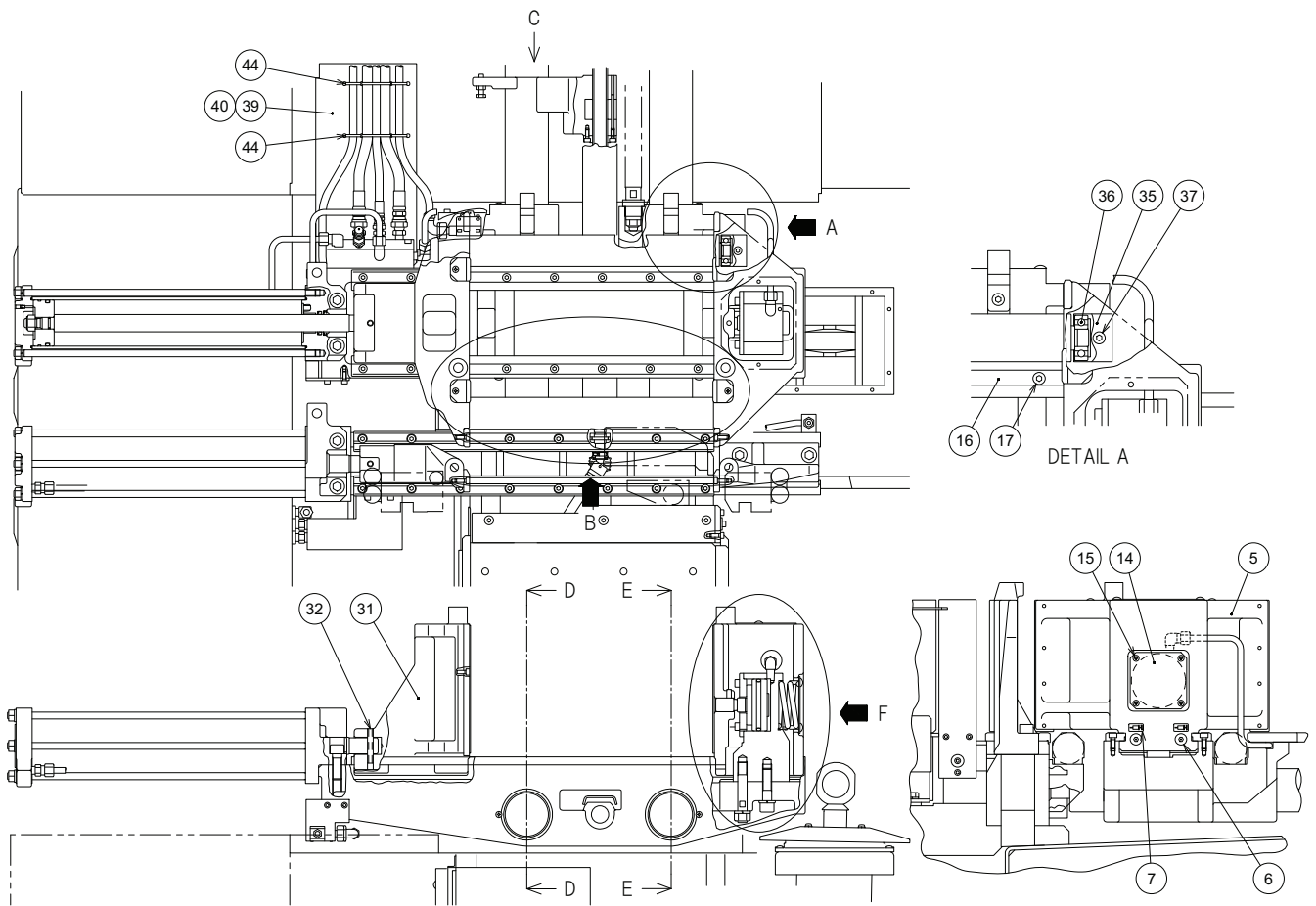

RB02618--A

Unit No. 55
Rear Vise(2)-2/3 <Rear Vise for EU Spec>

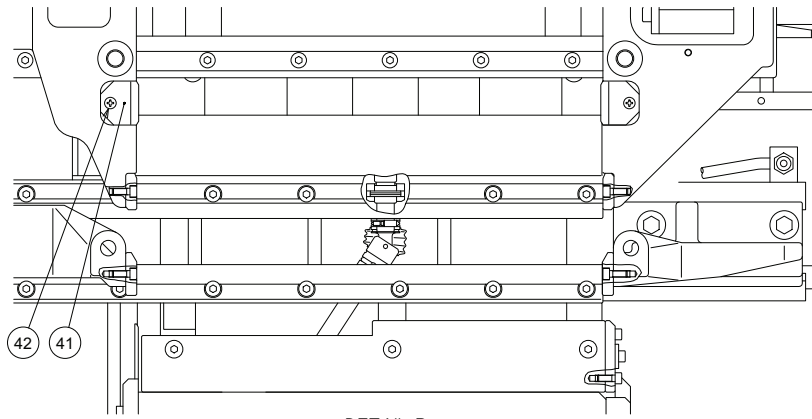

DETAIL B

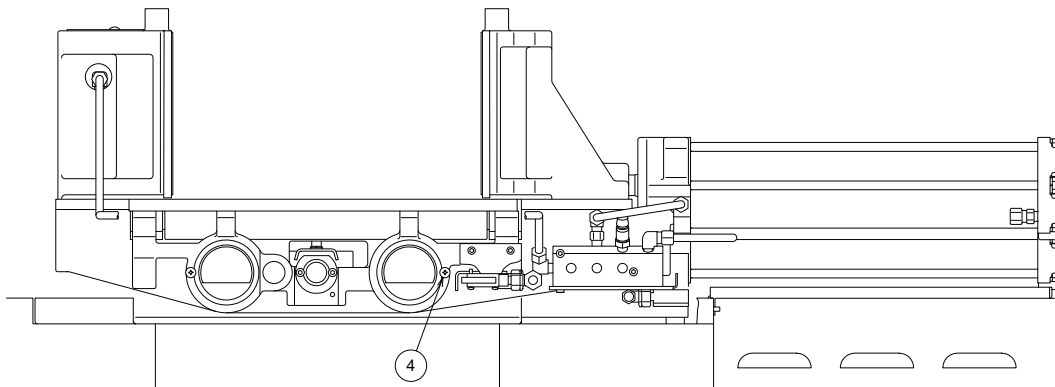

VIEW C

RB02618--A

Unit No. 55
 Rear Vise(2)-3/3 <Rear Vise for EU Spec>

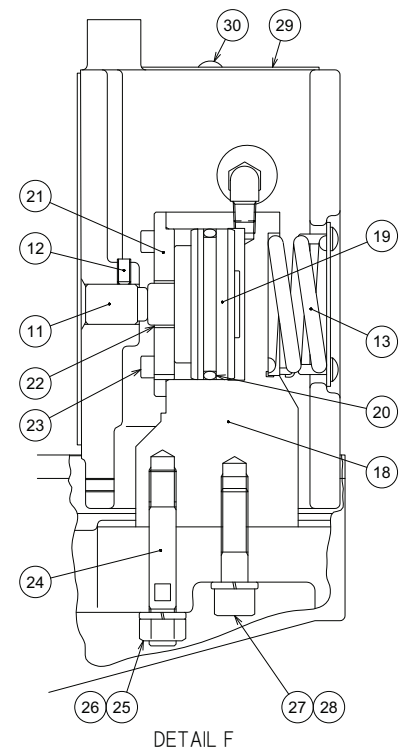
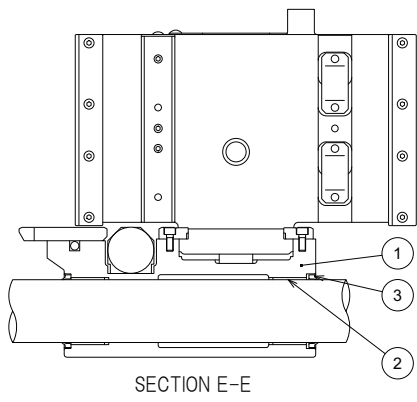
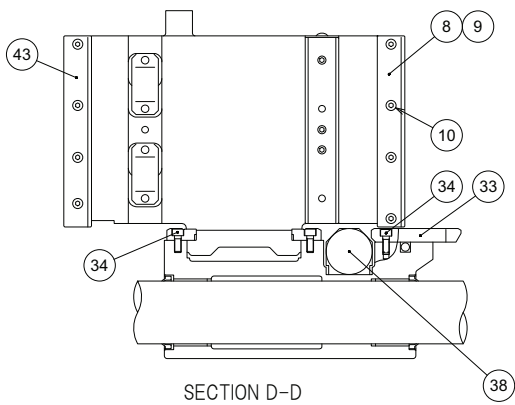

Unit No. 55
Rear Vise(2)

| Index | Code | Parts Name | Drawing No. | Type | Maker | Q'ty | Note |
|-------|----------|----------------------------|-------------|--------------------|----------|------|------|
| 1 | 10583698 | Rear Vise Bed | 1238492 E | | | 1 | |
| 2 | 10301324 | Plain Bearing | RB0054082- | SF-1 7540 | KBT | 4 | |
| 3 | 10375805 | Wiper Ring | P590313017 | SCB-75 | SAKAGAMI | 4 | |
| 4 | 10340019 | Truss Head Screw | P334130012 | M6X12 | JIS | 4 | |
| 5 | 10380650 | Rear Vise Jaw (Stationary) | 1238473 | | | 1 | |
| 6 | 10419913 | Grease Nipple | P560600002 | A-MT6X1 | JIS | 2 | |
| 7 | 10323010 | Name Plate | 0852250 | | | 2 | |
| 8 | 10378365 | Rear Vise Plate | 1238687 A | | | 3 | |
| 9 | 10378369 | Stationary Vise Shim | 1238484 | | | 1 | |
| 10 | 10312831 | Hex Socket Cap Screw | P330220006 | M6X15 | | 16 | |
| 11 | 10567020 | Pushing Screw | 1230669 A | | | 1 | |
| 12 | 10329311 | Socket Set Screw | P330590058 | M8X15(Dimple Type) | MOURI | 1 | |
| 13 | 10301157 | Spring | 1230677 A | | | 1 | |
| 14 | 10332711 | Spring Retainer | 1230670 | | | 1 | |
| 15 | 10322133 | Truss Head Screw | P334130014 | M6X20 | JIS | 4 | |
| 16 | 10301173 | Slide Plate | 1238493 B | | | 2 | |
| 17 | 10322202 | Hex Socket Cap Screw | P330230006 | M8X20 | | 20 | |
| 18 | 10316910 | Cylinder | 1230673 | | | 1 | |
| 19 | 10316917 | Stationary Vise Piston | 1230674 | | | 1 | |

Unit No. 55
Rear Vise(2)

| Index | Code | Parts Name | Drawing No. | Type | Maker | Q'ty | Note |
|-------|----------|--------------------------|-------------|---------|-------------|------|------|
| 20 | 10316808 | O Ring | P590000064 | P80 | | 1 | |
| 21 | 10332607 | Cylinder Cap | 1230675 A | | | 1 | |
| 22 | 10581365 | Plain Bearing | P407003207 | DUB2512 | DAIDO METAL | 1 | |
| 23 | 10322202 | Hex Socket Cap Screw | P330230006 | M8X20 | | 4 | |
| 24 | 10313646 | Reamer Bolt | 1230676 | | | 1 | |
| 25 | 10322218 | Spring Washer | P336050010 | 16 | JIS | 1 | |
| 26 | 10421756 | Nut | P332000009 | M16 | JIS | 1 | |
| 27 | 10332954 | Hex Socket Cap Screw | P330260036 | M16X60 | | 1 | |
| 28 | 10322153 | Conical Spring Washer | P336165005 | CDW-16H | HHK | 1 | |
| 29 | 10378370 | Cover | 1238497 | | | 1 | |
| 30 | 10340019 | Truss Head Screw | P334130012 | M6X12 | JIS | 2 | |
| 31 | 10583699 | Rear Vise Movable Jaw | 1238474 B | | | 1 | |
| 32 | 10322112 | Spring Pin | P337030096 | 10X60AW | OHKITA | 1 | |
| 33 | 10301158 | Auxiliary Plate | 1230971 | | | 1 | |
| 34 | 10322202 | Hex Socket Cap Screw | P330230006 | M8X20 | | 2 | |
| 35 | 10376204 | Roller Bracket | 1233020 B | | | 2 | |
| 36 | 10555909 | Deep Groove Ball Bearing | P400017017 | 6304DDU | NSK | 2 | |
| 37 | 10342326 | Hex Socket Cap Screw | P330230012 | M8X50 | | 2 | |
| 38 | 10378048 | Roller | 1238488 A | | | 1 | |

Unit No. 55
Rear Vise(2)

| Index | Code | Parts Name | Drawing No. | Type | Maker | Q'ty | Note |
|-------|----------|----------------------|-------------|--------|----------|------|------|
| 39 | 10583702 | Plate | 1230679 B | | | 1 | |
| 40 | 10323201 | Hex Socket Cap Screw | P330220004 | M6X12 | JIS | 2 | |
| 41 | 10380642 | Vise Plate Cover | 1280733 A | | | 4 | |
| 42 | 10332134 | Truss Head Screw | P334130010 | M6X8 | JIS | 4 | |
| 43 | 10419350 | Rear Vise Plate 2 | 1238886 | | | 1 | |
| 44 | 10375463 | Cable Band | P381058035 | SKB-2M | KITAGAWA | 12 | |

Unit No. 56
Rear Vise(3) <Rear Vise Guard for EU Spec>

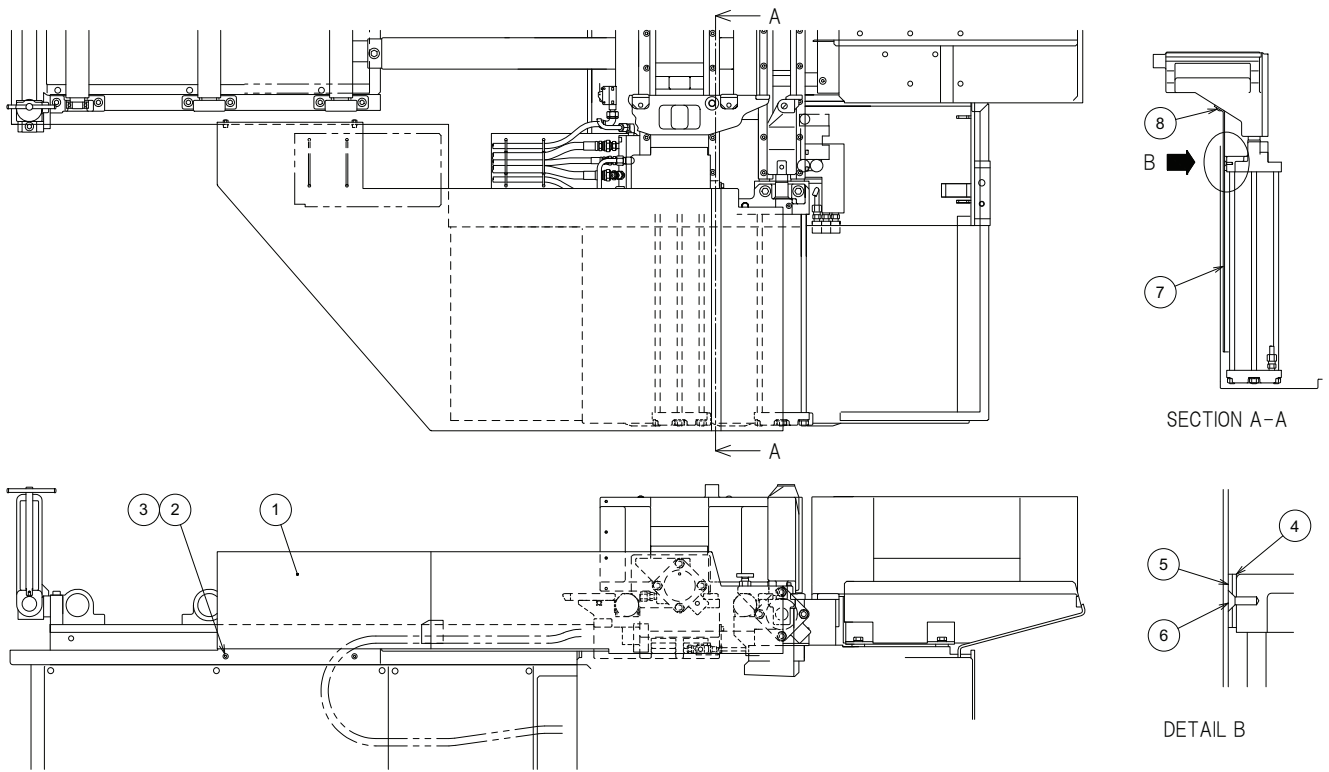

1230341A

Unit No. 56
Rear Vise(3)

| Index | Code | Parts Name | Drawing No. | Type | Maker | Q'ty | Note |
|-------|----------|--------------------------|-------------|-----------|-------------|------|------|
| 1 | 10301162 | Cylinder Cover | 1230975 A | | | 1 | |
| 2 | 10323201 | Hex Socket Cap Screw | P330220004 | M6X12 | JIS | 3 | |
| 3 | 10321922 | Washer | P336000005 | 6(Normal) | JIS | 3 | |
| 4 | 10301260 | Pusher | 1440952 | | | 1 | |
| 5 | 10301261 | Guide Plate | 1440953 | | | 2 | |
| 6 | 10328361 | Flat Head Bolt | P334520016 | M6X12 | NISSAN NEJI | 2 | |
| 7 | 10301262 | Rear Vise Cylinder Cover | 1440954 | | | 1 | |
| 8 | 10385708 | Truss Head Screw | P334130011 | M6X10 | JIS | 2 | |

Unit No. 57
Rear Vise(4) <Uplift Prevention Plate ASSY>

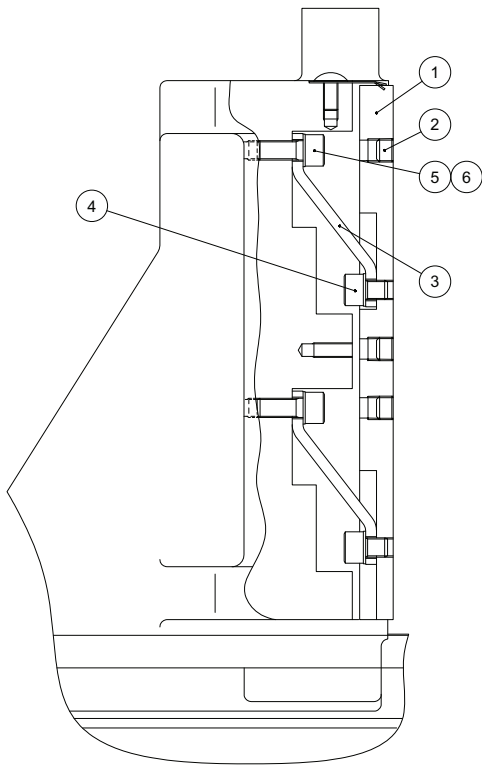

SECTION A-A

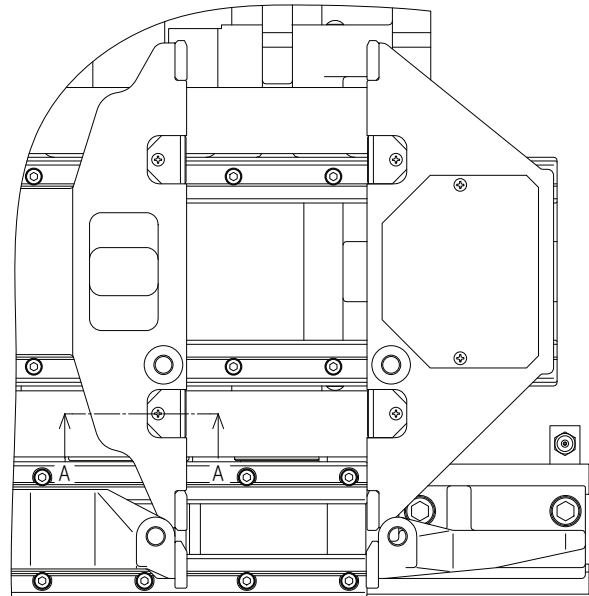

1238677
(1278801--A)

Unit No. 57
Rear Vise(4)

| Index | Code | Parts Name | Drawing No. | Type | Maker | Q'ty | Note |
|-------|----------|-----------------------|-------------|--------|-------|------|------|
| 1 | 10332574 | Plate | 1238685 B | | | 4 | |
| 2 | 10380409 | Plug for Piping | P580208022 | PT-1/8 | | 12 | |
| 3 | 10313822 | Leaf Spring | 1280732 A | | | 8 | |
| 4 | 10323206 | Hex Socket Cap Screw | P330230002 | M8X12 | JIS | 8 | |
| 5 | 10322202 | Hex Socket Cap Screw | P330230006 | M8X20 | | 8 | |
| 6 | 10301322 | Conical Spring Washer | QZZ036564 | H-8 | | 16 | |

Unit No. 58
Rear Vise(5)-1/2 <Limit Switch>

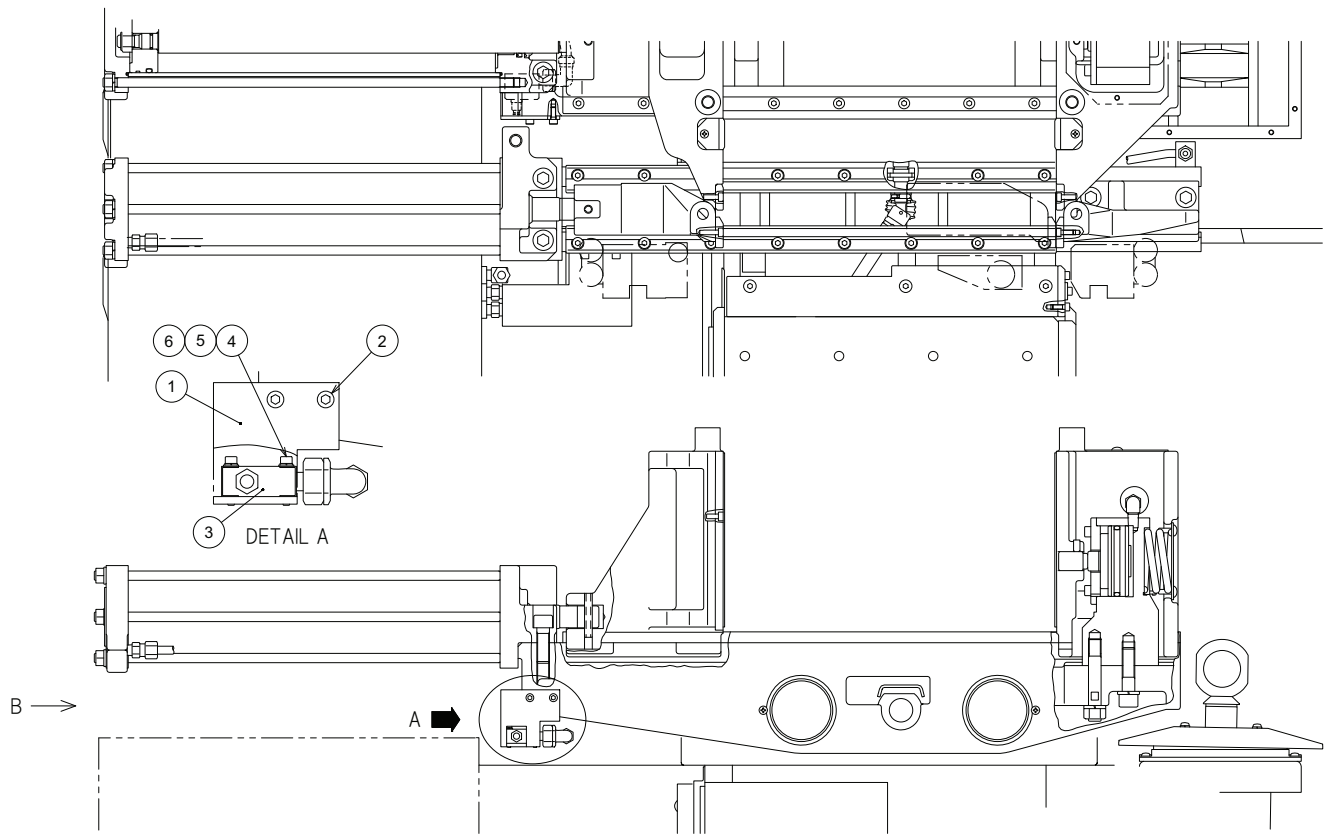

1278802---
(1278801--A)

Unit No. 58
Rear Vise(5)-2/2 <Limit Switch>

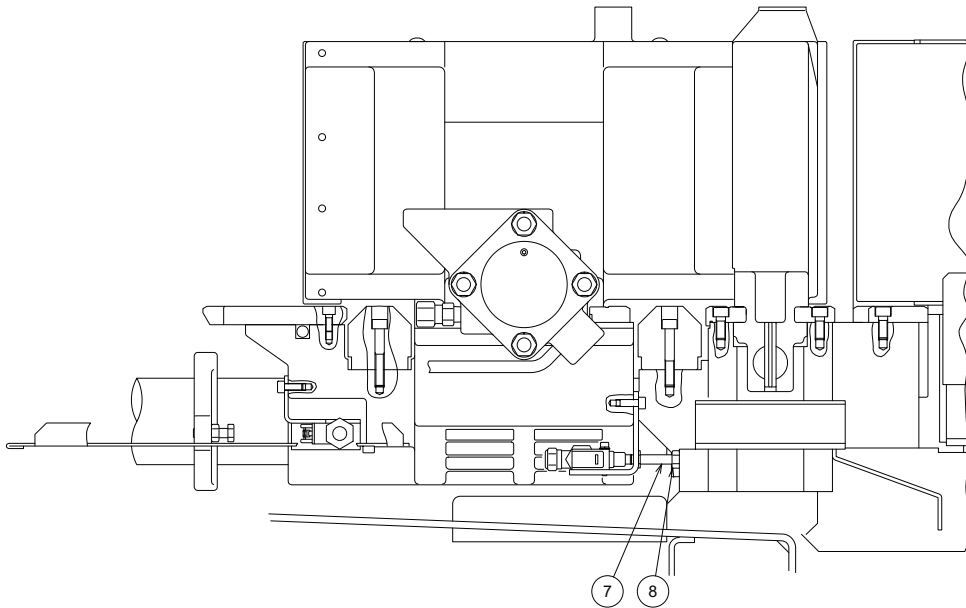

VIEW B

1278802---
(1278801--A)

Unit No. 58
Rear Vise(5)

| Index | Code | Parts Name | Drawing No. | Type | Maker | Q'ty | Note |
|-------|----------|----------------------|-------------|-------------------|----------|------|------|
| 1 | 10419768 | LS Bracket | 1238495 B | | | 1 | |
| 2 | 10323204 | Hex Socket Cap Screw | P330220007 | M6X16 | JIS | 2 | |
| 3 | 10318839 | Limit Switch | P828013017 | SL1-S155 | YAMATAKE | 1 | |
| 4 | 10363419 | Hex Socket Cap Screw | P330200022 | M4X25 | | 2 | |
| 5 | 10337110 | Washer | P336000003 | 4(Small Round) | JIS | 2 | |
| 6 | 10318527 | Spring Washer | P336050003 | 4 | JIS | 2 | |
| 7 | 10382724 | Bolt | P330030014 | M8X45(All-thread) | MOURI | 1 | |
| 8 | 10589226 | Nut | P332000005 | M8 | JIS | 1 | |

Unit No. 59
Rear Vise(6)-1/2 <EU Specification Machine>

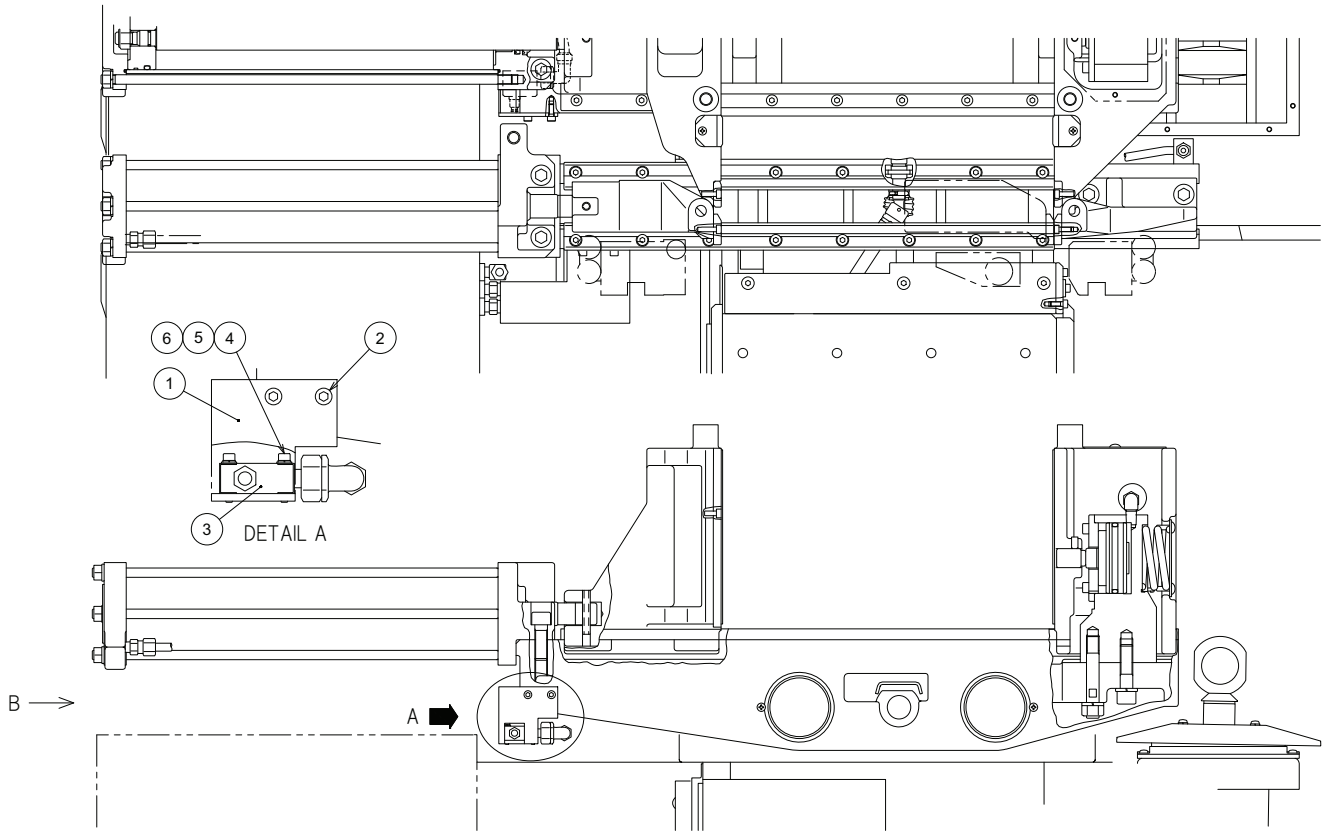

RB02690---
(1278801--A)

Unit No. 59
Rear Vise(6)-2/2 <EU Specification Machine>

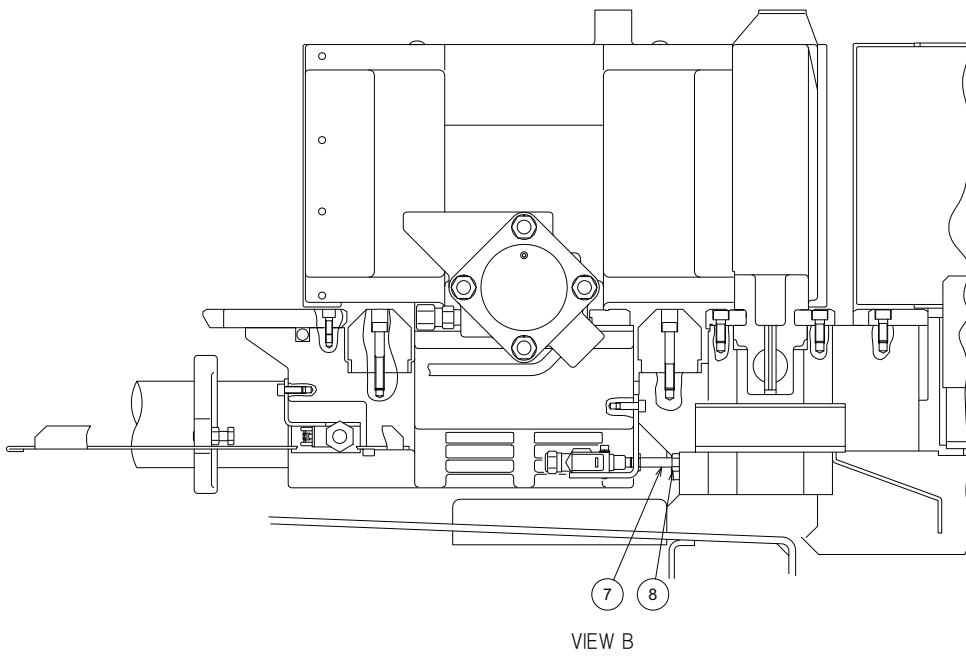

RB02690---
(1278801--A)

Unit No. 59
Rear Vise(6)

| Index | Code | Parts Name | Drawing No. | Type | Maker | Q'ty | Note |
|-------|----------|----------------------|-------------|-------------------|----------|------|------|
| 1 | 10419768 | LS Bracket | 1238495 B | | | 1 | |
| 2 | 10323204 | Hex Socket Cap Screw | P330220007 | M6X16 | JIS | 2 | |
| 3 | 10318839 | Limit Switch | P828013017 | SL1-S155 | YAMATAKE | 1 | |
| 4 | 10363419 | Hex Socket Cap Screw | P330200022 | M4X25 | | 2 | |
| 5 | 10337110 | Washer | P336000003 | 4(Small Round) | JIS | 2 | |
| 6 | 10318527 | Spring Washer | P336050003 | 4 | JIS | 2 | |
| 7 | 10386758 | Bolt | P330030037 | M8X80(All-thread) | MOURI | 1 | |
| 8 | 10589226 | Nut | P332000005 | M8 | JIS | 1 | |

Unit No. 60
Rear Vise(7) <Vise Cylinder>

1 Index 2-21

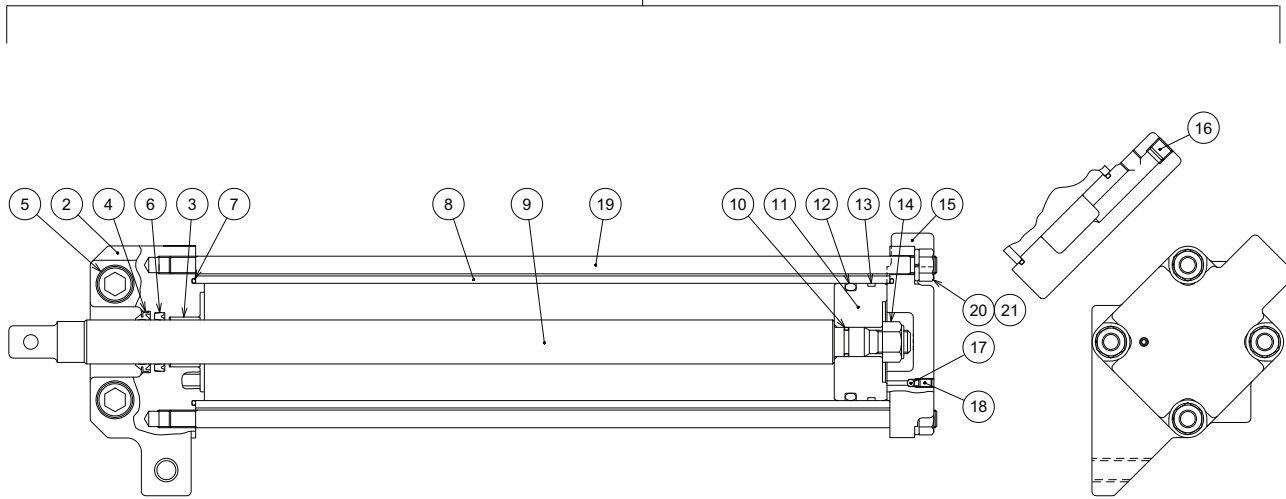

Unit No. 60
Rear Vise(7)

| Index | Code | Parts Name | Drawing No. | Type | Maker | Q'ty | Note |
|-------|----------|--------------------------|-------------|------------------------------------|---------------|------|-----------------|
| 1 | 10302092 | Vise Cylinder ASSY | SBS0125--- | 1238370 A, 1238366, 1238372 others | | 1 | with Index 2-21 |
| 2 | 10301171 | Cylinder Cap F | 1238370 A | | | 1 | |
| 3 | 10300163 | Plain Bearing | P407003176 | DUB3020 | DAIDO METAL | 1 | |
| 4 | 10338202 | Wiper Ring | P590313004 | SCB-30 | SAKAGAMI | 1 | |
| 5 | 10332953 | Hex Socket Cap Screw | P330260033 | M16X45 | | 2 | |
| 6 | 10376483 | Piston Packing | P590403023 | SKY-30 | SAKAGAMI | 1 | |
| 7 | 10383406 | O Ring | P590012012 | 1A-G80 | NOK | 2 | |
| 8 | 10378290 | Cylinder | 1238366 | | | 1 | |
| 9 | 10378291 | Piston Rod | 1238367 A | | | 1 | |
| 10 | 10589448 | O Ring | P590000018 | P20 | | 1 | |
| 11 | 10378295 | Piston | 1238372 | | | 1 | |
| 12 | 10001114 | O Ring | P590000061 | P70 | | 1 | |
| 13 | 10359913 | Wearing | P590473021 | SWB-80 | SAKAGAMI | 1 | |
| 14 | 10375004 | Locking Nut | P332505010 | M16(Type-1) | FUJI SEIMITSU | 1 | |
| 15 | 10419313 | Cylinder Cap R | 1238884 A | | | 1 | |
| 16 | 10300171 | Plug for Piping | P580208021 | PT-1/4 | | 1 | |
| 17 | 10332944 | Steel Ball (for Bearing) | P406000002 | 3/16 | JIS | 1 | |
| 18 | 10356511 | Socket Set Screw | P330570017 | M6X12(Dog-end) | JIS | 1 | |
| 19 | 10419314 | Tie Rod | 1238885 | | | 4 | |

Unit No. 60
Rear Vise(7)

| Index | Code | Parts Name | Drawing No. | Type | Maker | Q'ty | Note |
|-------|----------|---------------|-------------|------|-------|------|------|
| 20 | 10589227 | Nut | P332000007 | M12 | JIS | 4 | |
| 21 | 10000829 | Spring Washer | P336050008 | 12 | JIS | 4 | |

Unit No. 61
 Chip Conveyor(1)-1/2

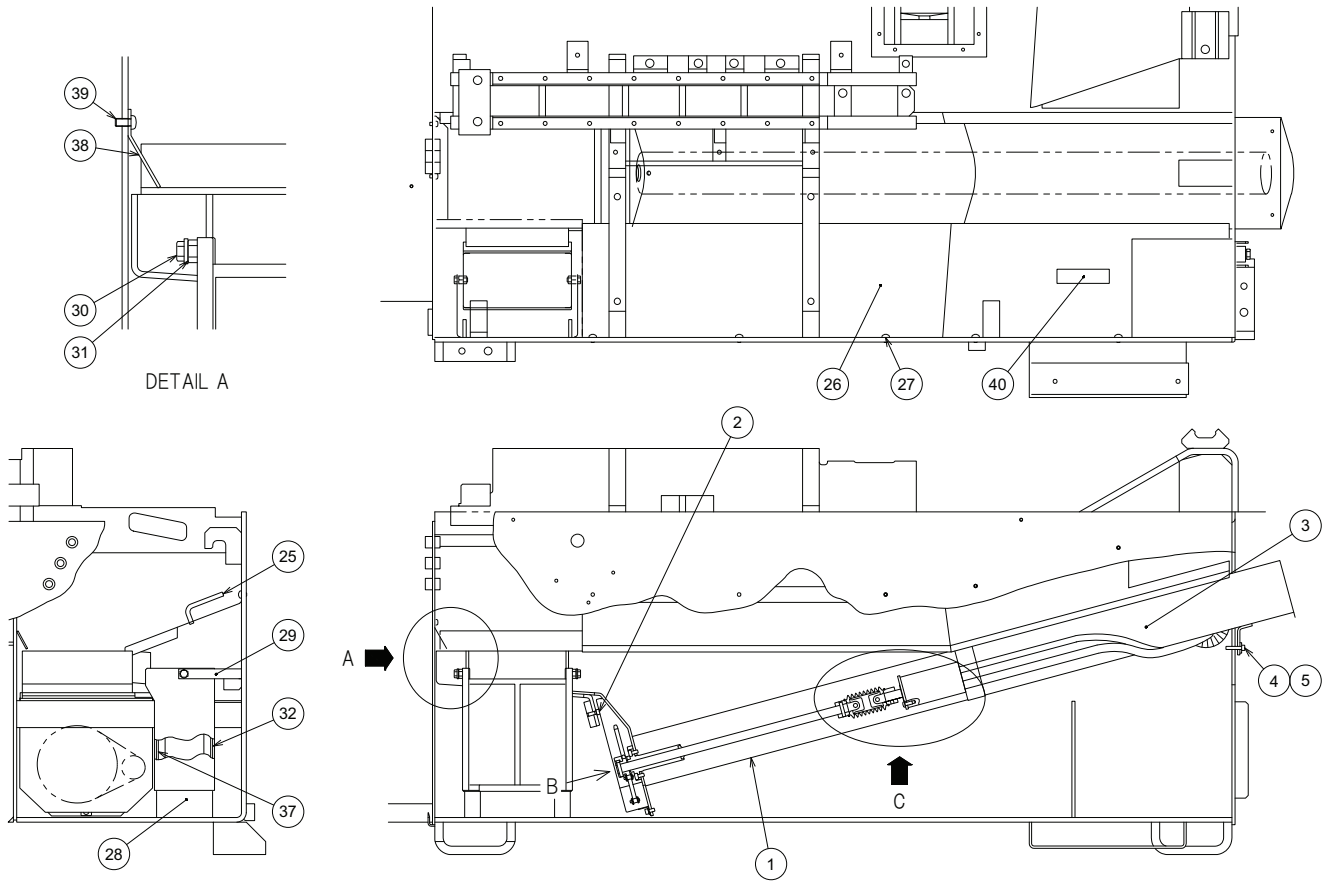

1278805--A

Unit No. 61
Chip Conveyor(1)-2/2

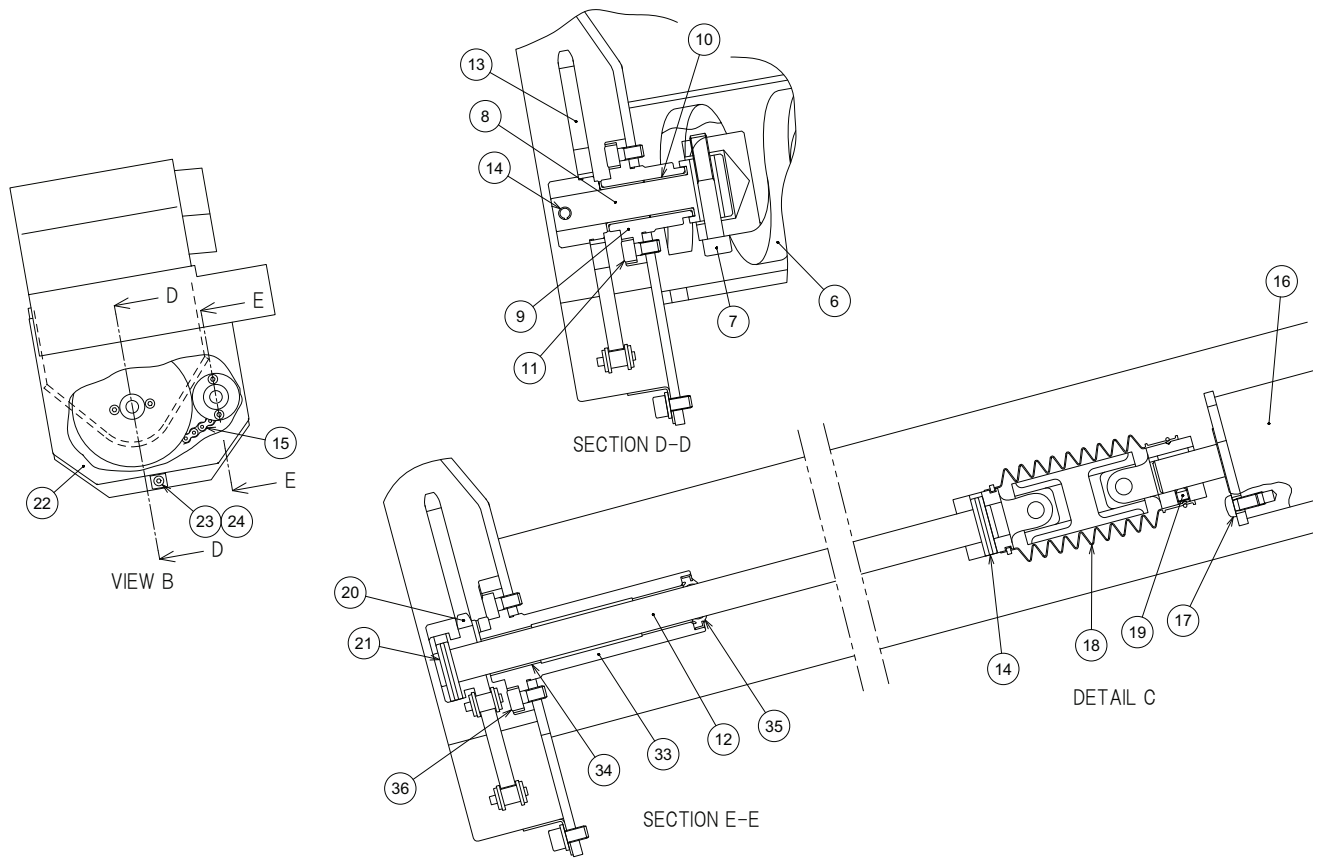

1278805--A

Unit No. 61
Chip Conveyor(1)

| Index | Code | Parts Name | Drawing No. | Type | Maker | Q'ty | Note |
|-------|----------|----------------------|-------------|--------------------|-------------------|------|------|
| 1 | 10378636 | Spiral Case | 1238576 B | | | 1 | |
| 2 | 10380788 | Hex Socket Cap Screw | P330220027 | M6X16-A2-70-SUS304 | MOURI | 1 | |
| 3 | 10378637 | Spiral Pipe | 1238577 | | | 1 | |
| 4 | 10376462 | Washer | 1233546 A | | | 2 | |
| 5 | 10325418 | Hex Socket Cap Screw | P330220012 | M6X30 | | 2 | |
| 6 | 10378651 | Spiral Shaft | 7922587 | FUT-002 | FUTABA HATSUJO | 1 | |
| 7 | 10342326 | Hex Socket Cap Screw | P330230012 | M8X50 | | 1 | |
| 8 | 10331042 | Shaft A | 1280685 B | | | 1 | |
| 9 | 10331164 | Shaft Support A | 1280686 B | | | 1 | |
| 10 | 10301296 | Plain Bearing | P407013087 | K5F1620-24 | DAIDO METAL | 2 | |
| 11 | 10375811 | Hex Socket Cap Screw | P330220028 | M6X12-A2-70-SUS304 | MOURI | 2 | |
| 12 | 10378632 | Shaft B | 1233544 | | | 1 | |
| 13 | 10331149 | Sprocket A | 1280687 C | RS40-36T,Type-A | | 1 | |
| 14 | 10328305 | Spring Pin | P337030062 | 6X28AW | JIS | 2 | |
| 15 | 10331135 | Chain | P410122052 | RS40SL-42L(JL) | TSUBAKIMOTO CHAIN | 1 | |
| 16 | 10331059 | Hydraulic Motor | P541008001 | OMM32-151G0003 | DANFOSS | 1 | |
| 17 | 10328359 | Button Head Screw | P334500014 | M6X12 | JIS | 3 | |
| 18 | 10583708 | Universal Joint | 124469724 | | | 1 | |
| 19 | 10312833 | Socket Set Screw | P330590017 | M6X6(Dimple Type) | JIS | 1 | |

Unit No. 61

Chip Conveyor(1)

| Index | Code | Parts Name | Drawing No. | Type | Maker | Q'ty | Note |
|-------|----------|----------------------|-------------|---------------------|-------------|------|------|
| 20 | 10331150 | Sprocket B | 1280690 B | RS40-10T,Type-B New | | 1 | |
| 21 | 10328305 | Spring Pin | P337030062 | 6X28AW | JIS | 1 | |
| 22 | 10378634 | Chain Cover | 1233567 | | | 1 | |
| 23 | 10375811 | Hex Socket Cap Screw | P330220028 | M6X12-A2-70-SUS304 | MOURI | 1 | |
| 24 | 10321922 | Washer | P336000005 | 6(Normal) | JIS | 1 | |
| 25 | 10378638 | Chute 1 | 1238578 A | | | 1 | |
| 26 | 10419539 | Chute 2 | 1244667 | | | 1 | |
| 27 | 10340019 | Truss Head Screw | P334130012 | M6X12 | JIS | 5 | |
| 28 | 10378640 | Chip Box | 1238580 | | | 1 | |
| 29 | 10331155 | Grip | 1280695 A | | | 1 | |
| 30 | 10325826 | Bolt | P330030006 | M8X20 | | 2 | |
| 31 | 10589226 | Nut | P332000005 | M8 | JIS | 2 | |
| 32 | 10331032 | Screen | 1280696 A | | | 1 | |
| 33 | 10331165 | Shaft Support B | 1280689 C | | | 1 | |
| 34 | 10301295 | Plain Bearing | P407003300 | K5B1625 | DAIDO METAL | 2 | |
| 35 | 10331236 | Wiper Ring | P590313002 | SCB-16 | SAKAGAMI | 1 | |
| 36 | 10375811 | Hex Socket Cap Screw | P330220028 | M6X12-A2-70-SUS304 | MOURI | 2 | |
| 37 | 10378635 | Screen A | 1233569 | | | 1 | |
| 38 | 10419352 | Side Cover | 1238590 B | | | 1 | |

Unit No. 61
Chip Conveyor(1)

| Index | Code | Parts Name | Drawing No. | Type | Maker | Q'ty | Note |
|-------|----------|------------------|-------------|-------|-------|------|------|
| 39 | 10340019 | Truss Head Screw | P334130012 | M6X12 | JIS | 2 | |
| 40 | 10300875 | Sticker | RB00869--A | | | 1 | |

Unit No. 62
Chip Conveyor(2) <EU Specification Machine>

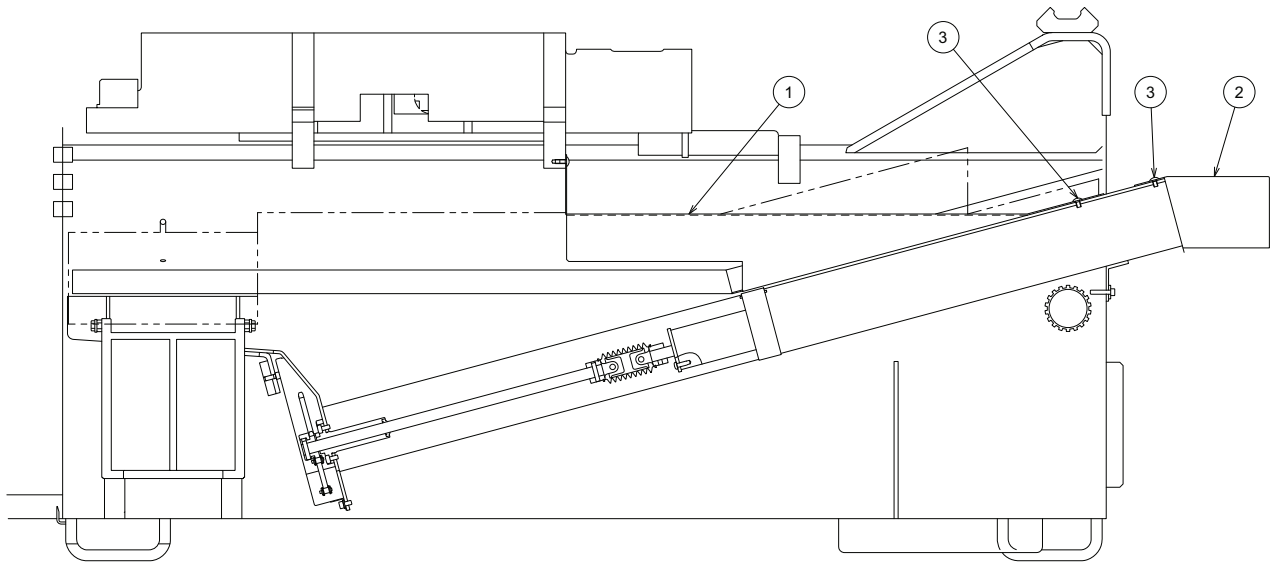

1440909B

Unit No. 62
Chip Conveyor(2)

| Index | Code | Parts Name | Drawing No. | Type | Maker | Q'ty | Note |
|-------|----------|-------------------|-------------|-------|-------|------|------|
| 1 | 10301255 | Spiral Case Cover | 1440910 A | | | 1 | |
| 2 | 10420412 | Cover | 1440911 | | | 1 | |
| 3 | 10385708 | Truss Head Screw | P334130011 | M6X10 | JIS | 4 | |

Unit No. 63
Work Light

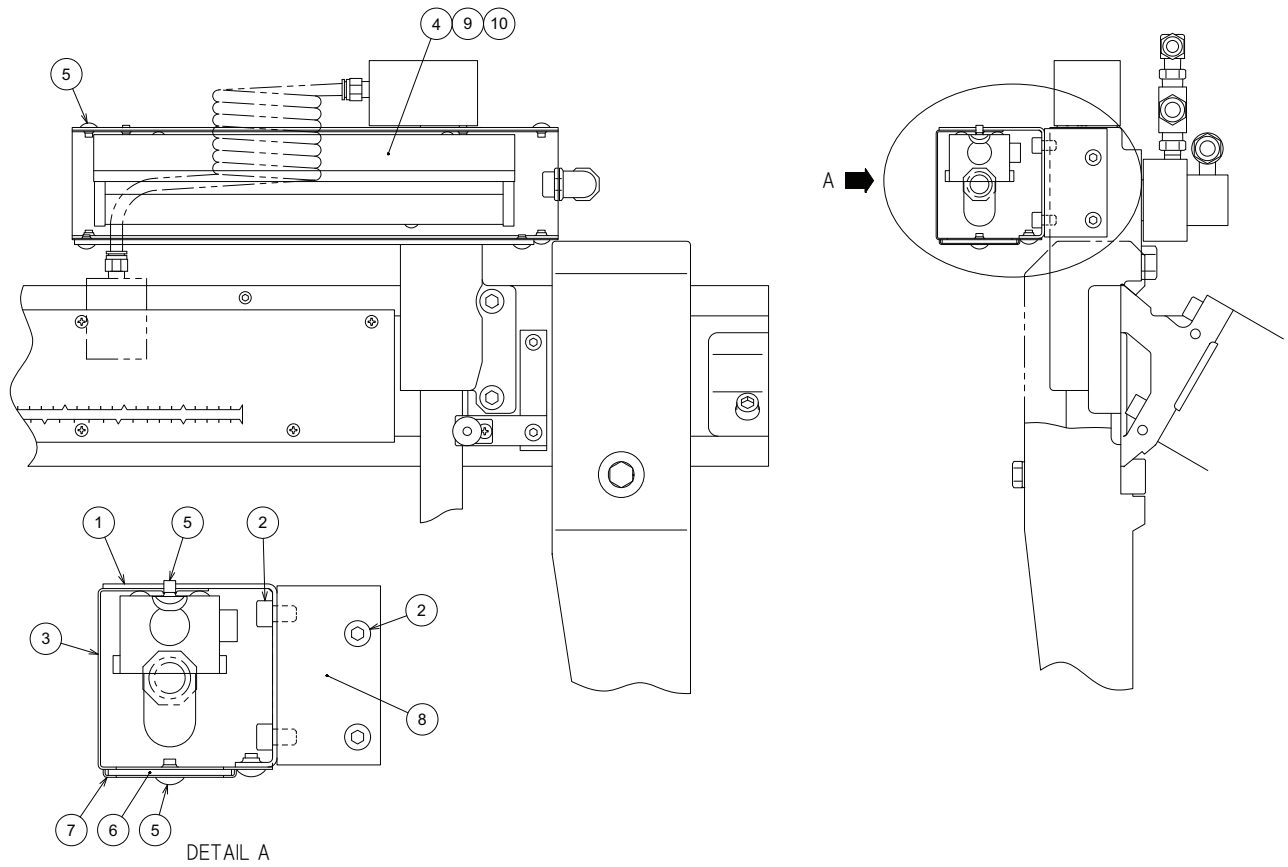

Unit No. 63
Work Light

| Index | Code | Parts Name | Drawing No. | Type | Maker | Q'ty | Note |
|-------|----------|--------------------------------|-------------|---------------|-------|------|------|
| 1 | 10301181 | Upper Cover | 1278448--- | | | 1 | |
| 2 | 10323206 | Hex Socket Cap Screw | P330230002 | M8X12 | JIS | 4 | |
| 3 | 10301182 | Under Cover | 1278449--A | | | 1 | |
| 4 | 10300107 | Fluorescent Lamp Unit | 7720422--- | M-1114T11-A/B | | 1 | |
| 5 | 10332134 | Truss Head Screw | P334130010 | M6X8 | JIS | 8 | |
| 6 | 10336503 | Acrylic Cover | 1280832 | | | 1 | |
| 7 | 10336504 | Cover Holder | 1280834 | | | 1 | |
| 8 | 10419353 | Bracket | 142966813 | W90XT4.5 | | 1 | |
| 9 | 10337544 | Fluorescence Lamp | P850308001 | FL10W | NEC | 1 | |
| 10 | 10583709 | Accessory for Fluorescent Lamp | P850318001 | FG-7E | NEC | 1 | |

Unit No. 64
Electric DOM(1) <Cable>

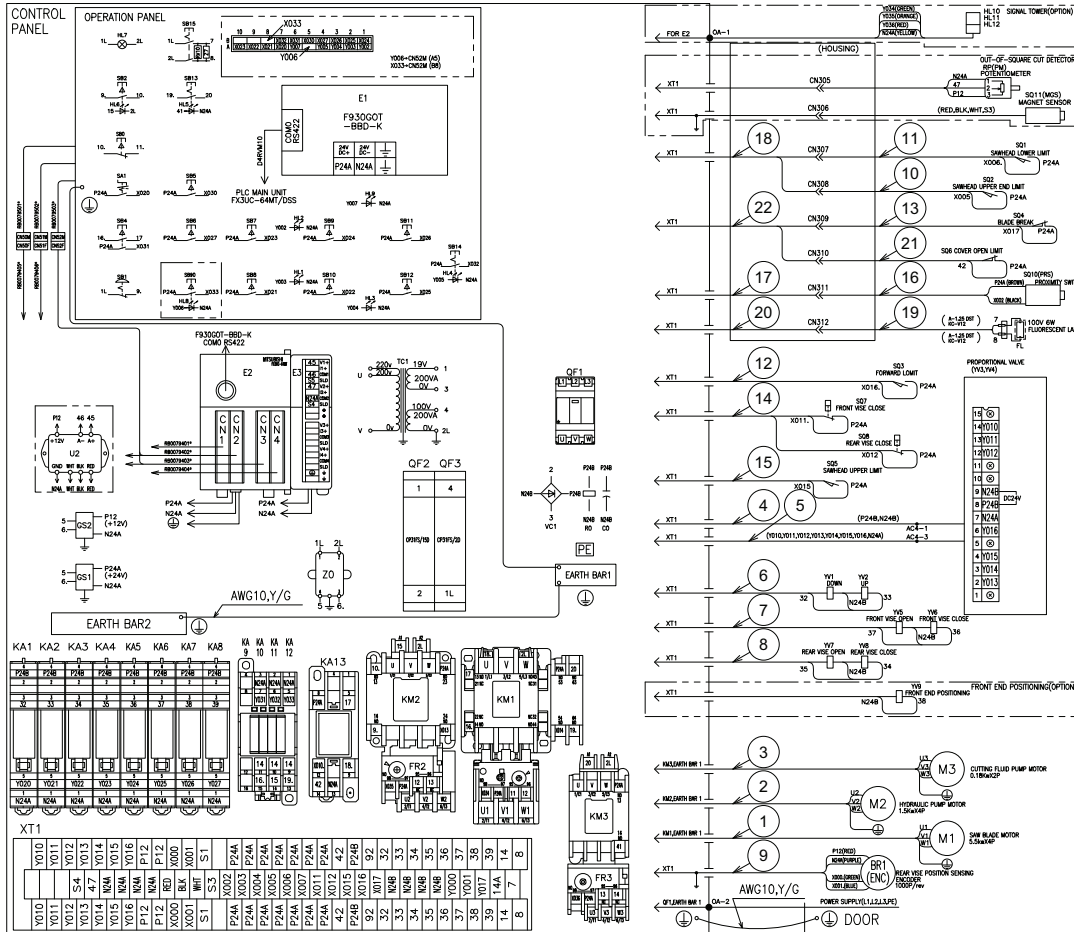

Unit No. 64
Electric DOM(1)

| Index | Code | Parts Name | Drawing No. | Type | Maker | Q'ty | Note |
|-------|----------|-----------------------------------|-------------|------|-------|------|------|
| 1 | 10301332 | Saw Blade Motor Cable | RB0153801A | | | 1 | |
| 2 | 10301333 | Hydraulic Motor Cable | RB0153802A | | | 1 | |
| 3 | 10301334 | Cutting Fluid Pump Motor Cable | RB0153803A | | | 1 | |
| 4 | 10301957 | Proportional Valve Cable (Power) | RB0153804A | | | 1 | |
| 5 | 10301958 | Proportional Valve Cable (Signal) | RB0153805B | | | 1 | |
| 6 | 10301959 | Rase/Lower SOL Cable | RB0153806A | | | 1 | |
| 7 | 10301960 | Front Vise SOL Cable | RB0153808A | | | 1 | |
| 8 | 10301961 | Rear Vise SOL Cable | RB0153809A | | | 1 | |
| 9 | 10301779 | Work Feeding ENC Cable | RB0152310A | | | 1 | |
| 10 | 10301962 | Sawhead Upper Limit LS Cable | RB0153811A | | | 1 | |
| 11 | 10301963 | Lower Limit LS Cable | RB0153812A | | | 1 | |
| 12 | 10301964 | Forward Limit LS Cable | RB0153814A | | | 1 | |
| 13 | 10301965 | Blade Break LS Cable | RB0153815A | | | 1 | |
| 14 | 10301784 | Front/Rear Vise Close LS Cable | RB0152317B | | | 1 | |
| 15 | 10301966 | LS Cable | RB0153819A | | | 1 | |
| 16 | 10301967 | AMD Motion Detector Cable | RB0153820A | | | 1 | |
| 17 | 10301968 | AMD Junction Cable | RB0153821A | | | 1 | |
| 18 | 10301969 | Housing Junction Cable 1 | RB0153822A | | | 1 | |
| 19 | 10301970 | Working Light Cable | RB0153823A | | | 1 | |

Unit No. 64
Electric DOM(1)

| Index | Code | Parts Name | Drawing No. | Type | Maker | Q'ty | Note |
|-------|----------|-------------------------------|-------------|------|-------|------|------|
| 20 | 10301971 | Working Light Junction Cable | RB0153824A | | | 1 | |
| 21 | 10301972 | Cover Open Limit Switch Cable | RB0153825B | | | 1 | |
| 22 | 10301973 | Housing Junction Cable 2 | RB0153826A | | | 1 | |

Unit No. 65
 Electric DOM(2)-1/2 <Electrical Enclosure>

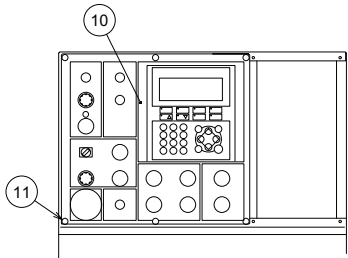

VIEW A

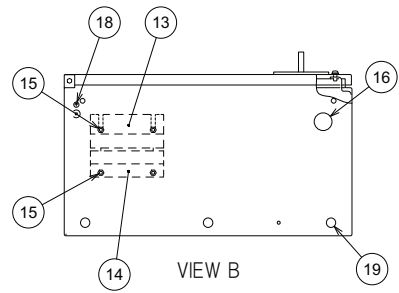
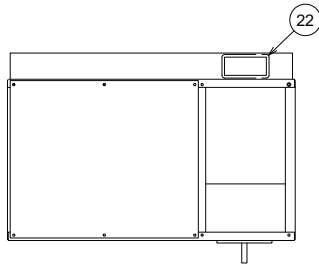

VIEW B

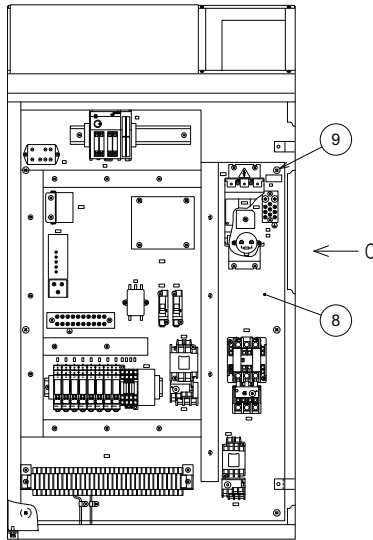
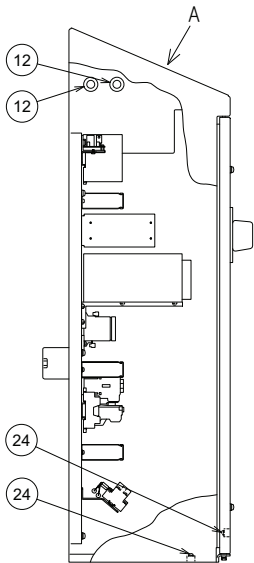

B

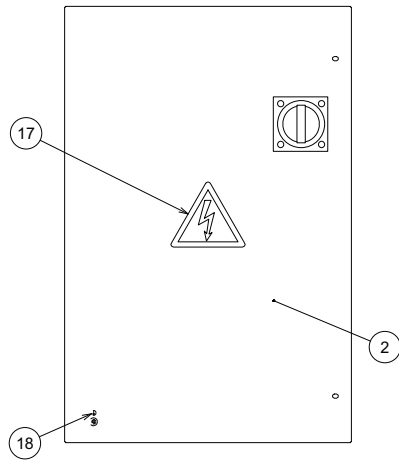

RB02502--D

Unit No. 65
 Electric DOM(2)-2/2 <Electrical Enclosure>

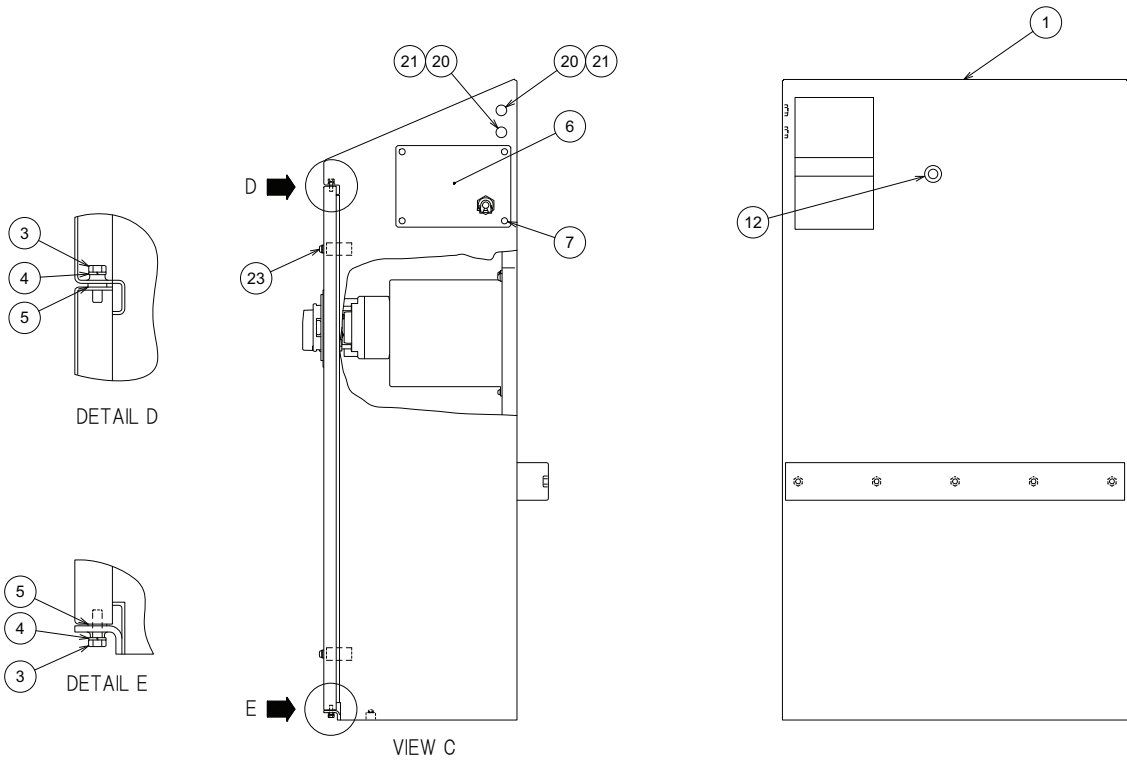

RB02502--D

Unit No. 65
Electric DOM(2)

| Index | Code | Parts Name | Drawing No. | Type | Maker | Q'ty | Note |
|-------|----------|---------------------|-------------|------------------------------|-------|------|------|
| 1 | 10300821 | Control Box | RB00774--C | | | 1 | |
| 2 | 10300822 | Control Box Cover | RB00775--B | | | 1 | |
| 3 | 10325830 | Bolt | P330010005 | M5X16 | JIS | 2 | |
| 4 | 10322215 | Spring Washer | P336050004 | 5 | JIS | 2 | |
| 5 | 10323127 | Washer | P336000059 | 5(Polished Round) | JIS | 2 | |
| 6 | 10300824 | Cover | RB00776--B | | | 1 | |
| 7 | 10322224 | Pan Head Screw | P334100039 | M5X10 | JIS | 4 | |
| 8 | 10301987 | Panel Arrangement | RB01579--C | | | 1 | |
| 9 | 10325313 | Pan Head Screw | P334100058 | M6X16 | JIS | 6 | |
| 10 | 10301669 | Control Panel | RB00795--B | | | 1 | |
| 11 | 10372307 | Truss Head Screw | P334130009 | M5X12 | JIS | 6 | |
| 12 | 10301115 | Bush for Cable | RB0160001- | D22 | | 3 | |
| 13 | 10300830 | Cable Retainer A | RB00779--B | | | 1 | |
| 14 | 10300831 | Cable Retainer B | RB00780--B | | | 1 | |
| 15 | 10380944 | Sems Pan Head Screw | P334200063 | M6X16(Spring/Polished Round) | JIS | 4 | |
| 16 | 10301119 | CAPCON | RB0160006- | D34 | | 1 | |
| 17 | 10301069 | Charging Mark D | RB01517--- | 125MM | | 1 | |
| 18 | 10301068 | Sticker (Ground) | RB01516--- | | | 1 | |
| 19 | 10301120 | Grommet | RB0160007- | D18 | | 1 | |

Unit No. 65
Electric DOM(2)

| Index | Code | Parts Name | Drawing No. | Type | Maker | Q'ty | Note |
|-------|----------|----------------------|-------------|------------------------------|-------|------|------|
| 20 | 10321923 | Washer | P336000006 | 8(Normal) | JIS | 2 | |
| 21 | 10342325 | Hex Socket Cap Screw | P330230004 | M8X15 | | 2 | |
| 22 | 10301121 | Grommet | RB0160008- | W4XL250 | | 1 | |
| 23 | 10322133 | Truss Head Screw | P334130014 | M6X20 | JIS | 2 | |
| 24 | 10589252 | Sems Pan Head Screw | P334200013 | M4X10(Spring/Polished Round) | JIS | 2 | |

Unit No. 66
 Electric DOM(3)-1/2 <Panel Arrangement>

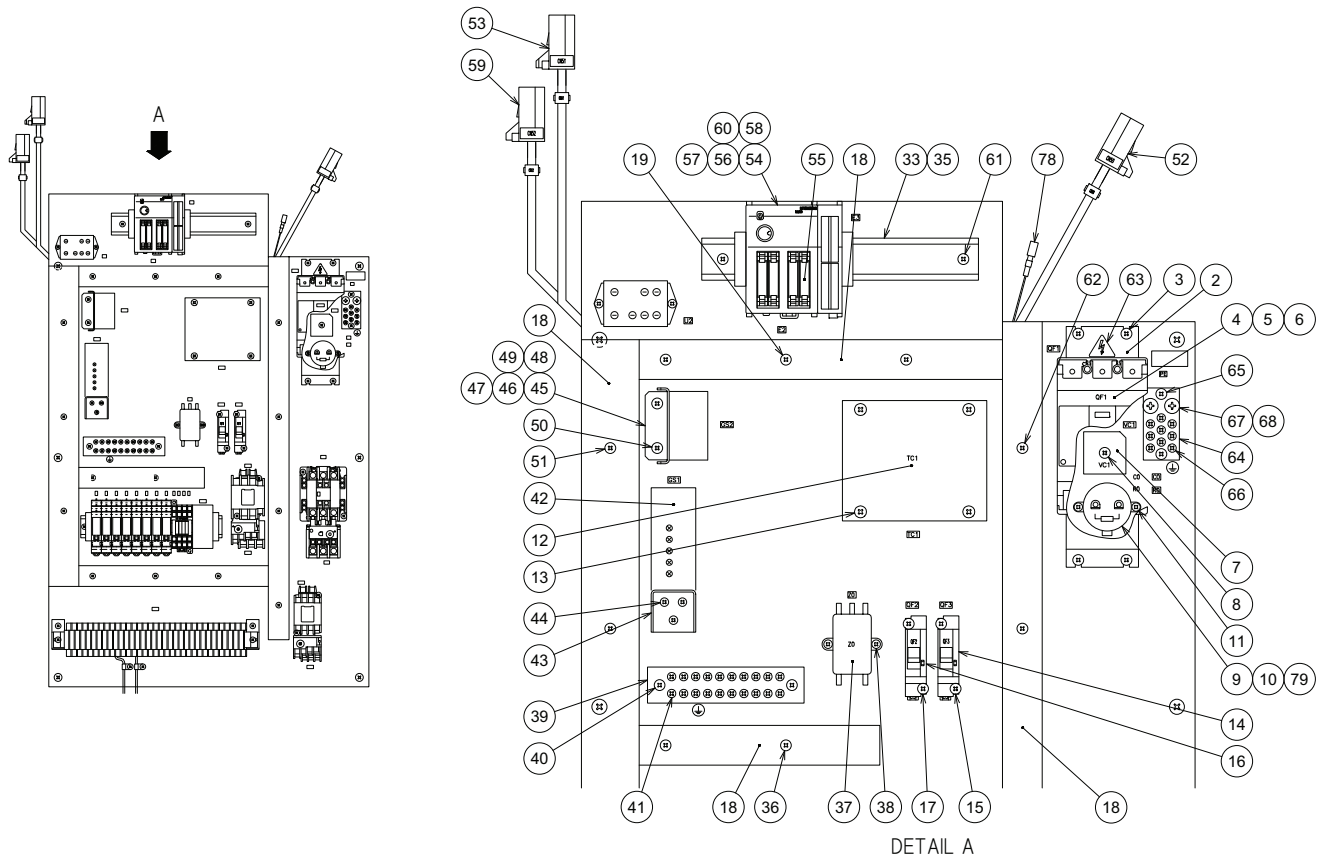

RB01579--C

Unit No. 66
 Electric DOM(3)-2/2 <Panel Arrangement>

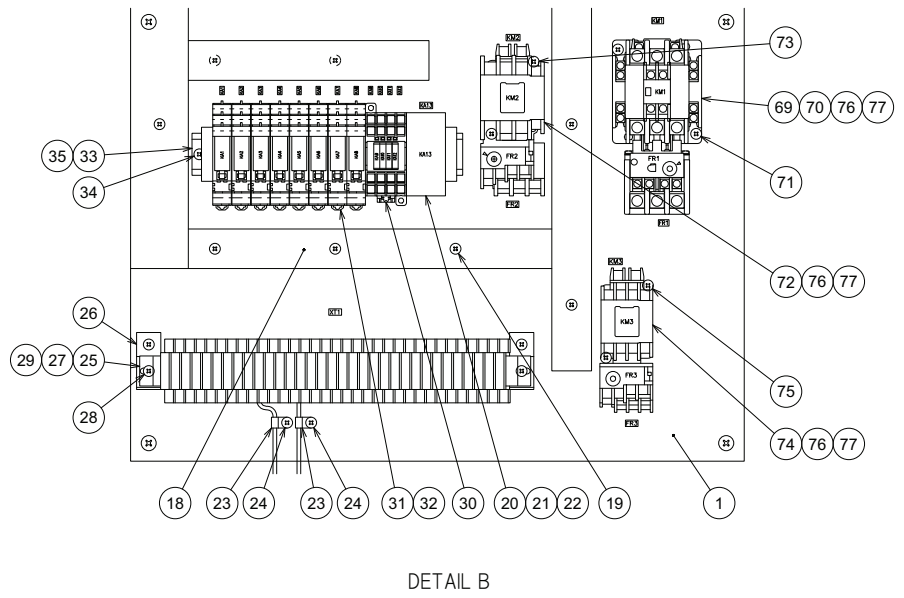
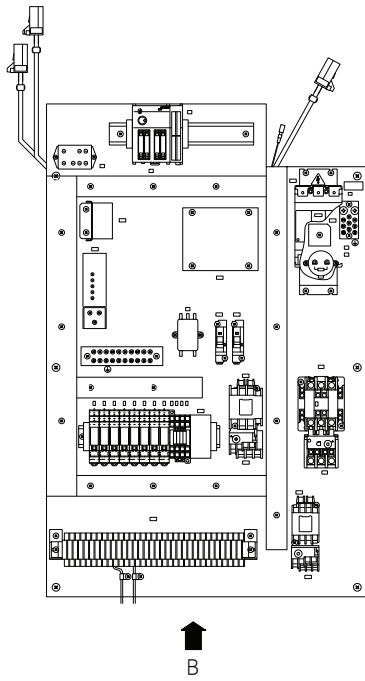

Unit No. 66
Electric DOM(3)

| Index | Code | Parts Name | Drawing No. | Type | Maker | Q'ty | Note |
|-------|----------|---------------------------------|-------------|------------------------------|---------------|------|------|
| 1 | 10301673 | Control Panel | RB00796--C | | | 1 | |
| 2 | 10300833 | Breaker Bracket | RB00782--C | | | 1 | |
| 3 | 10589252 | Sems Pan Head Screw | P334200013 | M4X10(Spring/Polished Round) | JIS | 4 | |
| 4 | 10301310 | Low Voltage Breaker | P812008031 | NF125-CVF-3P-75A | MITSUBISHI | 1 | QF1 |
| 5 | 10300195 | Accessory (Low Voltage Breaker) | P812098065 | TCL-05SV3 | MITSUBISHI | 1 | |
| 6 | 10300194 | Accessory (Low Voltage Breaker) | P812098064 | F-05SV | MITSUBISHI | 1 | |
| 7 | 10300207 | Rectifier | P840068014 | KBPC35-10 | SUMGLE | 1 | VC1 |
| 8 | 10589252 | Sems Pan Head Screw | P334200013 | M4X10(Spring/Polished Round) | JIS | 1 | |
| 9 | 10300211 | Aluminum Capacitor | P840108041 | 50V10000Micro Farad | HWAKAI | 1 | C0 |
| 10 | 10300212 | Resistor | P841128056 | RS2W(5.1 kOhm) | YCX | 1 | R0 |
| 11 | 10589250 | Sems Pan Head Screw | P334200010 | M3X10(Spring/Polished Round) | JIS | 2 | |
| 12 | 10300180 | Transformer | P772008054 | JBK5-400 | JUCHE | 1 | TC1 |
| 13 | 10380975 | Sems Pan Head Screw | P334200047 | M5X12(Spring/Polished Round) | JIS | 4 | |
| 14 | 10300196 | Low Voltage Breaker | P812128227 | CP31FS/2D | FUJI Electric | 1 | QF3 |
| 15 | 10380968 | Sems Pan Head Screw | P334200011 | M4X12(Spring/Polished Round) | JIS | 2 | |
| 16 | 10300197 | Low Voltage Breaker | P812128280 | CP31FS/15D | FUJI Electric | 1 | QF2 |
| 17 | 10589252 | Sems Pan Head Screw | P334200013 | M4X10(Spring/Polished Round) | JIS | 2 | |
| 18 | 10301676 | Duct | RB00799--A | | | 1 | |
| 19 | 10589252 | Sems Pan Head Screw | P334200013 | M4X10(Spring/Polished Round) | JIS | 6 | |

Unit No. 66
Electric DOM(3)

| Index | Code | Parts Name | Drawing No. | Type | Maker | Q'ty | Note |
|-------|----------|---------------------------------|-------------|------------------------------|-------------------|------|--------|
| 20 | 10301576 | Control Relay | P800002015 | MY2N-D2-DC24V | OMRON | 1 | KA13 |
| 21 | 10300215 | Accessory for Connector | P862188020 | PYF08A | OMRON | 1 | |
| 22 | 10349515 | Accessory for Connector | P862188011 | PYC-A1 | OMRON | 1 | |
| 23 | 10579245 | Cable Clamp | P381048008 | EMT-2N | TAKEUCHI Industry | 2 | |
| 24 | 10589252 | Sems Pan Head Screw | P334200013 | M4X10(Spring/Polished Round) | JIS | 2 | |
| 25 | 10301675 | Terminal Block ASSY | RB00798--B | | | 1 | XT1 |
| 26 | 10301117 | Tilting Attachment | RB0160003- | (Conform to) BP23-2S | | 2 | |
| 27 | 10301661 | Written Order (Fixing Resistor) | RB0079407A | | | 1 | |
| 28 | 10589252 | Sems Pan Head Screw | P334200013 | M4X10(Spring/Polished Round) | JIS | 6 | |
| 29 | 10301579 | Resistor | P841128057 | RS5W(470 Ohm) | YCX | 2 | |
| 30 | 10421120 | Control Relay | P800004060 | RS4N-DE | FUJI Electric | 1 | KA9-12 |
| 31 | 10589483 | Control Relay | P800002075 | G2R-1-SND-DC24V | OMRON | 8 | KA1-8 |
| 32 | 10589484 | Accessory for Control Relay | P800082015 | P2RF-05-E | OMRON | 8 | |
| 33 | 10301679 | DIN Rail | RB00803--A | | | 1 | |
| 34 | 10589252 | Sems Pan Head Screw | P334200013 | M4X10(Spring/Polished Round) | JIS | 2 | |
| 35 | 10337281 | Terminal Parts | P864052008 | BNL6 | IDEC | 4 | |
| 36 | 10589252 | Sems Pan Head Screw | P334200013 | M4X10(Spring/Polished Round) | JIS | 2 | |
| 37 | 10337328 | Noise Filter | P840048003 | ZCB2203-11 | TDK | 1 | Z0 |
| 38 | 10589250 | Sems Pan Head Screw | P334200010 | M3X10(Spring/Polished Round) | JIS | 2 | |

Unit No. 66
Electric DOM(3)

| Index | Code | Parts Name | Drawing No. | Type | Maker | Q'ty | Note |
|-------|----------|---------------------------------|-------------|------------------------------|---------------|------|------|
| 39 | 10300834 | Ground Bar | RB00783--A | | | 1 | |
| 40 | 10380683 | Sems Pan Head Screw | P334200034 | M4X16(Spring/Polished Round) | JIS | 2 | |
| 41 | 10380682 | Sems Pan Head Screw | P334200032 | M4X6(Spring/Polished Round) | JIS | 20 | |
| 42 | 10579233 | Switching Power Supply | P772124027 | JWS50-24/A | DENSEI-LAMBDA | 1 | GS1 |
| 43 | 10579234 | Accessory for Power Supply | P772188003 | L-09 | DENSEI-LAMBDA | 1 | |
| 44 | 10589249 | Sems Pan Head Screw | P334200008 | M3X6(Spring/Polished Round) | JIS | 6 | |
| 45 | 10579235 | Switching Power Supply | P772123024 | LDA10F-12-SN | COSEL | 1 | GS2 |
| 46 | 10589249 | Sems Pan Head Screw | P334200008 | M3X6(Spring/Polished Round) | JIS | 2 | |
| 47 | 10301674 | LDA Power Supply Bracket | RB00797--B | | | 1 | |
| 48 | 10301662 | GS2 Primary Cable | RB0079408A | | | 1 | |
| 49 | 10301663 | GS2 Secondary Cable | RB0079409A | | | 1 | |
| 50 | 10589252 | Sems Pan Head Screw | P334200013 | M4X10(Spring/Polished Round) | JIS | 2 | CN50 |
| 51 | 10589252 | Sems Pan Head Screw | P334200013 | M4X10(Spring/Polished Round) | JIS | 3 | |
| 52 | 10301659 | Cable CN50F | RB0079405B | | | 1 | |
| 53 | 10301660 | Cable CN51F | RB0079406A | | | 1 | CN51 |
| 54 | 10301575 | Programmable Controller | P767406010 | FX3UC-64MT/DSS | MITSUBISHI | 1 | E2 |
| 55 | 10582061 | Accessory (Program Controller) | P767486029 | FX3U-FLROM-64 | MITSUBISHI | 1 | |
| 56 | 10579239 | Accessory (Indicator Apparatus) | P767588010 | D4RVM10 | Diatrend | 1 | |
| 57 | 10301655 | Cable CN1 | RB0079401C | | | 1 | |

Unit No. 66
Electric DOM(3)

| Index | Code | Parts Name | Drawing No. | Type | Maker | Q'ty | Note |
|-------|----------|---------------------------|-------------|------------------------------|---------------|------|---------|
| 58 | 10301656 | Cable CN2 | RB0079402A | | | 1 | |
| 59 | 10301657 | Cable CN3 | RB0079403A | | | 1 | CN52 |
| 60 | 10301658 | Cable CN4 | RB0079404B | | | 1 | |
| 61 | 10589252 | Sems Pan Head Screw | P334200013 | M4X10(Spring/Polished Round) | JIS | 2 | |
| 62 | 10589252 | Sems Pan Head Screw | P334200013 | M4X10(Spring/Polished Round) | JIS | 4 | |
| 63 | 10301123 | Charging Mark | RB0160010- | 20MM | | 1 | |
| 64 | 10300835 | Ground Bar | RB00784--A | | | 1 | PE |
| 65 | 10380683 | Sems Pan Head Screw | P334200034 | M4X16(Spring/Polished Round) | JIS | 2 | |
| 66 | 10380682 | Sems Pan Head Screw | P334200032 | M4X6(Spring/Polished Round) | JIS | 9 | |
| 67 | 10300140 | Sems Pan Head Screw | P334200084 | M6X8(Spring/Polished Round) | JIS | 2 | |
| 68 | 10300143 | Washer | P336000074 | 6(Polished Round)T=1.0 | JIS | 2 | |
| 69 | 10301309 | Magnet Switch | P810044071 | SW-N1(18A)AC100V | FUJI Electric | 1 | KM1,FR1 |
| 70 | 10589493 | Accessory (Magnet Switch) | P810184001 | SZ-A20 | FUJI Electric | 1 | |
| 71 | 10380683 | Sems Pan Head Screw | P334200034 | M4X16(Spring/Polished Round) | JIS | 2 | |
| 72 | 10581177 | Magnet Switch | P810044150 | SW-05(5A)AC100V-2A | FUJI Electric | 1 | KM2,FR2 |
| 73 | 10380683 | Sems Pan Head Screw | P334200034 | M4X16(Spring/Polished Round) | JIS | 2 | |
| 74 | 10580714 | Magnet Switch | P810044135 | SW-0(0.8A)AC100V | FUJI Electric | 1 | KM3,FR3 |
| 75 | 10380683 | Sems Pan Head Screw | P334200034 | M4X16(Spring/Polished Round) | JIS | 2 | |
| 76 | 10301116 | Spark Killer | RB0160002- | (Conform to) SKVB104120 | | 3 | |

Unit No. 66
Electric DOM(3)

| Index | Code | Parts Name | Drawing No. | Type | Maker | Q'ty | Note |
|-------|----------|--------------------|-------------|------------|--------------|------|-----------|
| 77 | 10300209 | Varistor | P840078054 | TUR20D471K | JOCOL | 9 | |
| 78 | 10300214 | Plug Type Terminal | P862148060 | PC-2005F | NICHIFU | 1 | N24A |
| 79 | 10301580 | Insulating Sleeve | P869238018 | OA-BCP5 | OHM Electric | 2 | |
| 80 | 10301079 | Name Plate | RB0154804A | | | 1 | List Only |

Unit No. 67
 Electric DOM(4) <Control Panel>

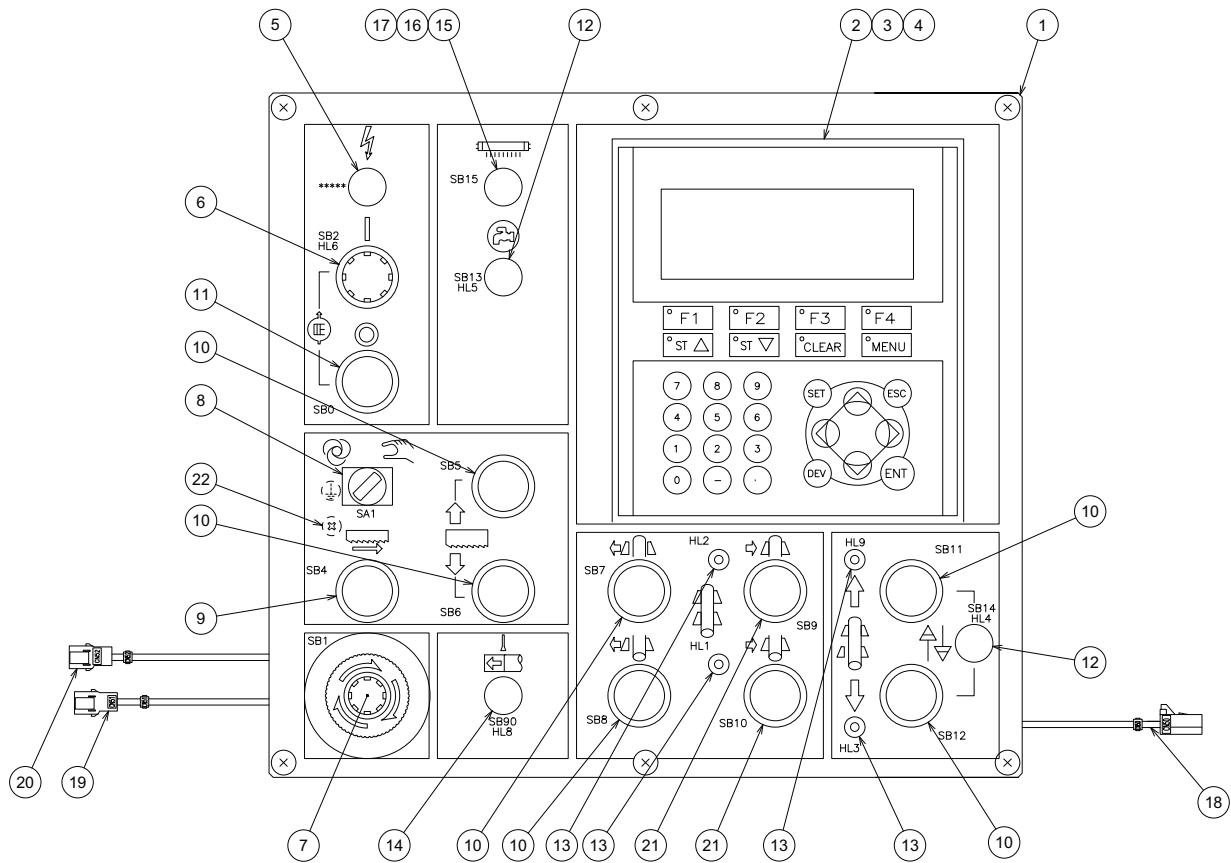

RB00795--B

Unit No. 67
Electric DOM(4)

| Index | Code | Parts Name | Drawing No. | Type | Maker | Q'ty | Note |
|-------|----------|---------------------------------|-------------|-------------------------|-----------------|------|-----------------|
| 1 | 10301677 | Name Plate | RB00800-B | | | 1 | |
| 2 | 10579261 | Indicator Apparatus | P767508019 | F930GOT-BBD-K | MITSUBISHI | 1 | |
| 3 | 10301678 | F Switch Sheet | RB00801--- | | | 1 | |
| 4 | 10579264 | Accessory (Indicator Apparatus) | P767588011 | F9GT-30PSC | MITSUBISHI | 2 | |
| 5 | 10300213 | Indicator Apparatus | P843024023 | AH165-ZWH3 | FUJI Electric | 1 | HL7 |
| 6 | 10579339 | Push Button Switch (with Lamp) | P822084031 | AR22F0L-10H3W | FUJI Electric | 1 | SB2,HL6 |
| 7 | 10300199 | Push Button Switch | P821084115 | AR22V0R-01R | FUJI Electric | 1 | SB1 |
| 8 | 10337159 | Key Select Switch | P820004027 | AH165-P2B11 | FUJI Electric | 1 | SA1 |
| 9 | 10579341 | Push Button Switch | P821084154 | AR22G2R-20W | FUJI Electric | 1 | SB4 |
| 10 | 10589510 | Push Button Switch | P821084080 | AR22F0R-10W | FUJI Electric | 6 | SB5,6,7,8,11,12 |
| 11 | 10300198 | Push Button Switch | P821084081 | AR22F0R-01B | FUJI Electric | 1 | SB0 |
| 12 | 10300204 | Push Button Switch (with Lamp) | P822064076 | AH165-L5W11E3 | FUJI Electric | 2 | SB13,14,HL4,5 |
| 13 | 10583452 | Indicator Apparatus | P843188016 | DB24-89WUS | MARUYASU DENGYO | 4 | HL1,2,3,9 |
| 14 | 10578823 | Blind Plug | P229138005 | AHX622-B | FUJI Electric | 1 | SB90,HL8 |
| 15 | 10337521 | Push Button Switch | P821064009 | AH165-E5W22 | FUJI Electric | 1 | SB15 |
| 16 | 10300208 | Varistor | P840078053 | TUR20D271K | JOCOL | 1 | |
| 17 | 10301116 | Spark Killer | RB0160002- | (Conform to) SKVB104120 | | 1 | |
| 18 | 10301670 | Cable (50m) | RB0079501A | | | 1 | CN50 |
| 19 | 10301671 | Cable (51m) | RB0079502A | | | 1 | CN51 |

Unit No. 67
Electric DOM(4)

| Index | Code | Parts Name | Drawing No. | Type | Maker | Q'ty | Note |
|-------|----------|---------------------|-------------|------------------------------|---------------|------|--------|
| 20 | 10301672 | Cable (52m) | RB0079503A | | | 1 | CN52 |
| 21 | 10300200 | Push Button Switch | P821084195 | AR22G2R-10W | FUJI Electric | 2 | SB9,10 |
| 22 | 10589252 | Sems Pan Head Screw | P334200013 | M4X10(Spring/Polished Round) | JIS | 1 | |

Unit No. 68
Electric US(1)

| Index | Code | Parts Name | Drawing No. | Type | Maker | Q'ty | Note |
|-------|----------|-----------------------------------|-------------|------|-------|------|------|
| 1 | 10301332 | Saw Blade Motor Cable | RB0153801A | | | 1 | |
| 2 | 10301333 | Hydraulic Motor Cable | RB0153802A | | | 1 | |
| 3 | 10301334 | Cutting Fluid Pump Motor Cable | RB0153803A | | | 1 | |
| 4 | 10301957 | Proportional Valve Cable (Power) | RB0153804A | | | 1 | |
| 5 | 10301958 | Proportional Valve Cable (Signal) | RB0153805B | | | 1 | |
| 6 | 10301959 | Rase/Lower SOL Cable | RB0153806A | | | 1 | |
| 7 | 10301960 | Front Vise SOL Cable | RB0153808A | | | 1 | |
| 8 | 10301961 | Rear Vise SOL Cable | RB0153809A | | | 1 | |
| 9 | 10301779 | Work Feeding ENC Cable | RB0152310A | | | 1 | |
| 10 | 10301962 | Sawhead Upper Limit LS Cable | RB0153811A | | | 1 | |
| 11 | 10301963 | Lower Limit LS Cable | RB0153812A | | | 1 | |
| 12 | 10301964 | Forward Limit LS Cable | RB0153814A | | | 1 | |
| 13 | 10301965 | Blade Break LS Cable | RB0153815A | | | 1 | |
| 14 | 10301784 | Front/Rear Vise Close LS Cable | RB0152317B | | | 1 | |
| 15 | 10301966 | LS Cable | RB0153819A | | | 1 | |
| 16 | 10301967 | AMD Motion Detector Cable | RB0153820A | | | 1 | |
| 17 | 10301968 | AMD Junction Cable | RB0153821A | | | 1 | |
| 18 | 10301969 | Housing Junction Cable 1 | RB0153822A | | | 1 | |
| 19 | 10301970 | Working Light Cable | RB0153823A | | | 1 | |

Unit No. 68
Electric US(1)

| Index | Code | Parts Name | Drawing No. | Type | Maker | Q'ty | Note |
|-------|----------|-------------------------------|-------------|------|-------|------|------|
| 20 | 10301971 | Working Light Junction Cable | RB0153824A | | | 1 | |
| 21 | 10301972 | Cover Open Limit Switch Cable | RB0153825B | | | 1 | |
| 22 | 10301973 | Housing Junction Cable 2 | RB0153826A | | | 1 | |

Unit No. 69
 Electric US(2)-1/2 <Electrical Enclosure>

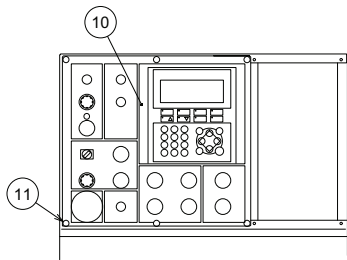

VIEW A

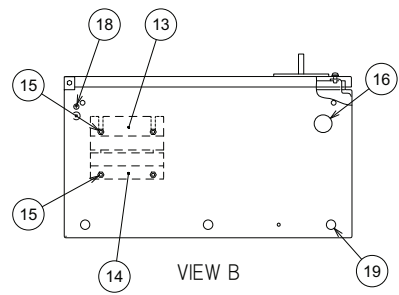
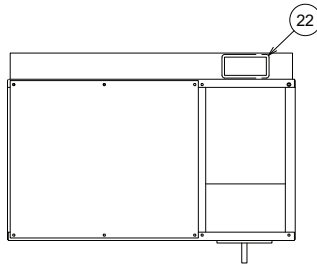

VIEW B

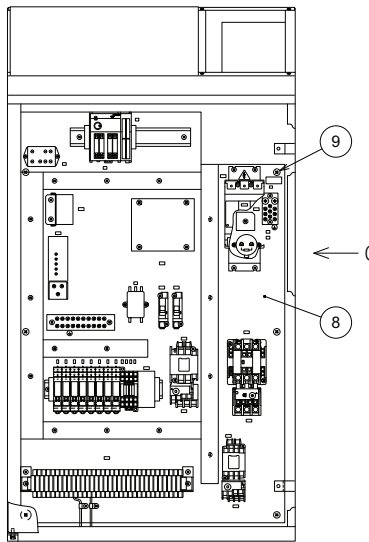
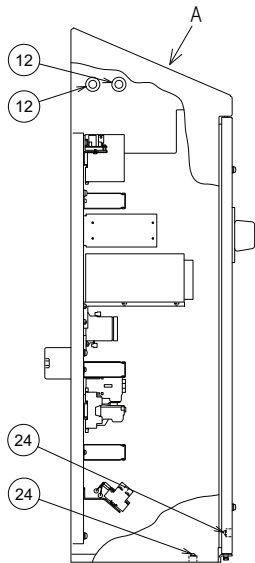

B

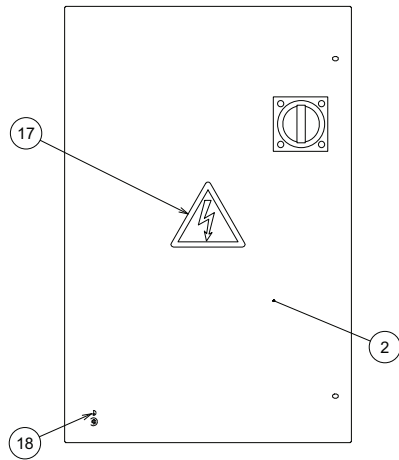

RB01539--C

Unit No. 69
Electric US(2)-2/2 <Electrical Enclosure>

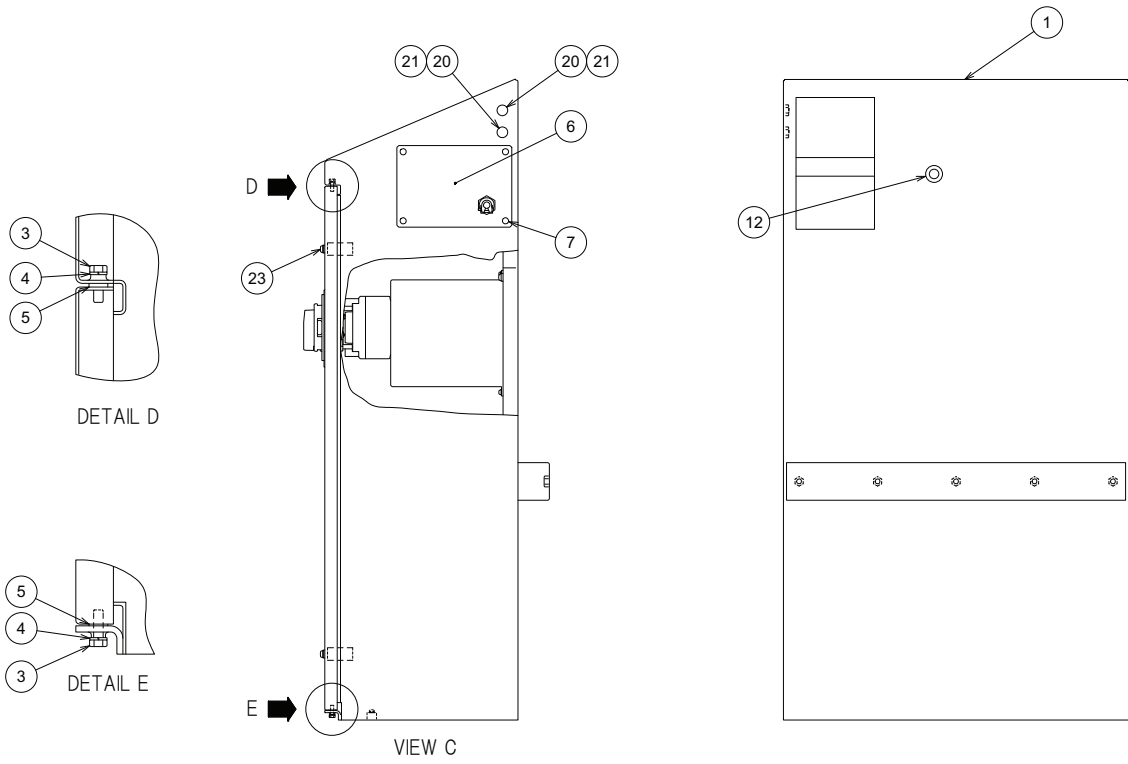

RB01539--C

Unit No. 69
Electric US(2)

| Index | Code | Parts Name | Drawing No. | Type | Maker | Q'ty | Note |
|-------|----------|---------------------|-------------|------------------------------|-------|------|------|
| 1 | 10300821 | Control Box | RB00774--C | | | 1 | |
| 2 | 10300822 | Control Box Cover | RB00775--B | | | 1 | |
| 3 | 10325830 | Bolt | P330010005 | M5X16 | JIS | 2 | |
| 4 | 10322215 | Spring Washer | P336050004 | 5 | JIS | 2 | |
| 5 | 10323127 | Washer | P336000059 | 5(Polished Round) | JIS | 2 | |
| 6 | 10300824 | Cover | RB00776--B | | | 1 | |
| 7 | 10322224 | Pan Head Screw | P334100039 | M5X10 | JIS | 4 | |
| 8 | 10301989 | Panel Arrangement | RB01581--C | | | 1 | |
| 9 | 10325313 | Pan Head Screw | P334100058 | M6X16 | JIS | 6 | |
| 10 | 10301669 | Control Panel | RB00795--B | | | 1 | |
| 11 | 10372307 | Truss Head Screw | P334130009 | M5X12 | JIS | 6 | |
| 12 | 10301115 | Bush for Cable | RB0160001- | D22 | | 3 | |
| 13 | 10300830 | Cable Retainer A | RB00779--B | | | 1 | |
| 14 | 10300831 | Cable Retainer B | RB00780--B | | | 1 | |
| 15 | 10380944 | Sems Pan Head Screw | P334200063 | M6X16(Spring/Polished Round) | JIS | 4 | |
| 16 | 10301119 | CAPCON | RB0160006- | D34 | | 1 | |
| 17 | 10301069 | Charging Mark D | RB01517--- | 125MM | | 1 | |
| 18 | 10301068 | Sticker (Ground) | RB01516--- | | | 1 | |
| 19 | 10301120 | Grommet | RB0160007- | D18 | | 1 | |

Unit No. 69
Electric US(2)

| Index | Code | Parts Name | Drawing No. | Type | Maker | Q'ty | Note |
|-------|----------|----------------------|-------------|------------------------------|-------|------|------|
| 20 | 10321923 | Washer | P336000006 | 8(Normal) | JIS | 2 | |
| 21 | 10342325 | Hex Socket Cap Screw | P330230004 | M8X15 | | 2 | |
| 22 | 10301121 | Grommet | RB0160008- | W4XL250 | | 1 | |
| 23 | 10322133 | Truss Head Screw | P334130014 | M6X20 | JIS | 2 | |
| 24 | 10589252 | Sems Pan Head Screw | P334200013 | M4X10(Spring/Polished Round) | JIS | 2 | |

Unit No. 70
 Electric US(3)-1/2 <Panel Arrangement>

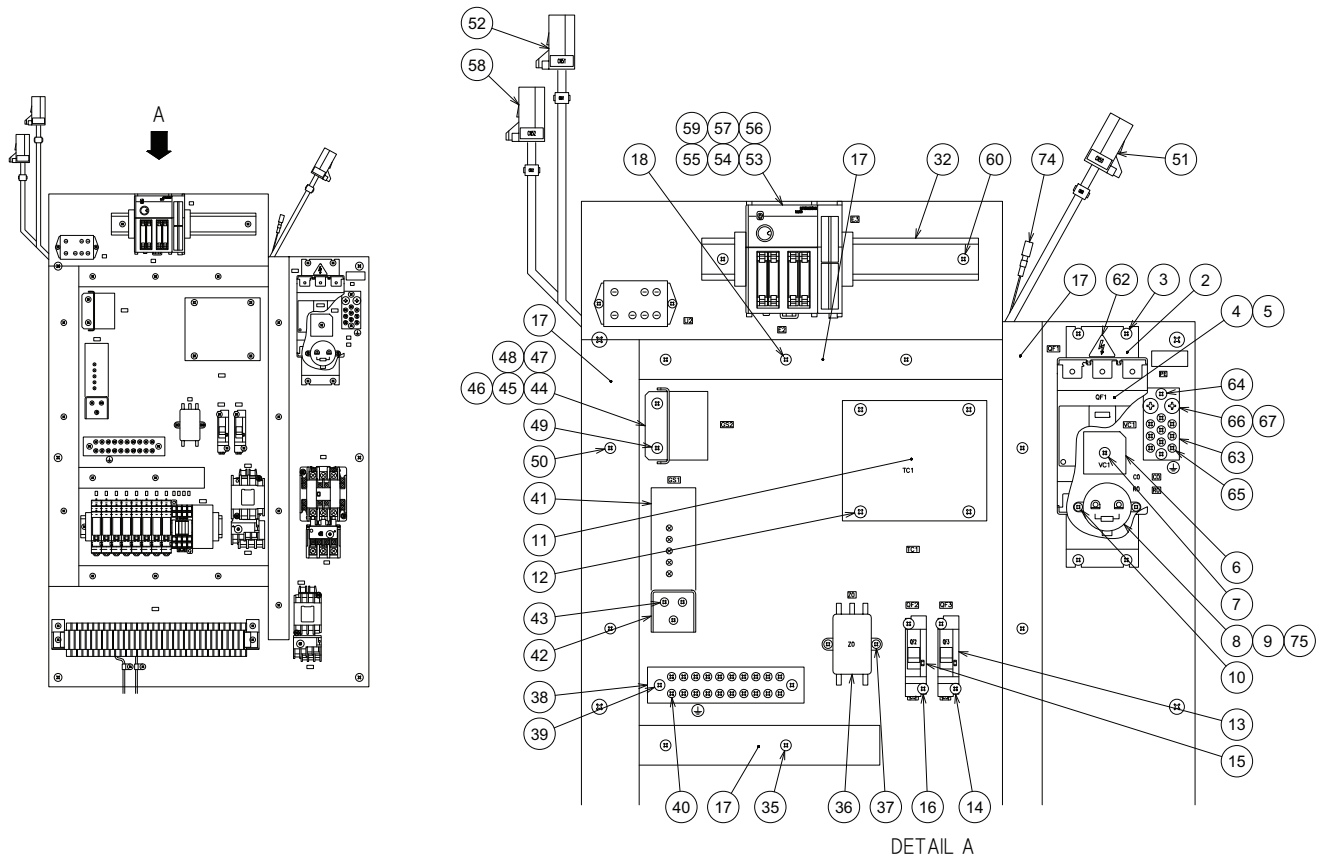

RB01581--C

Unit No. 70
 Electric US(3)-2/2 <Panel Arrangement>

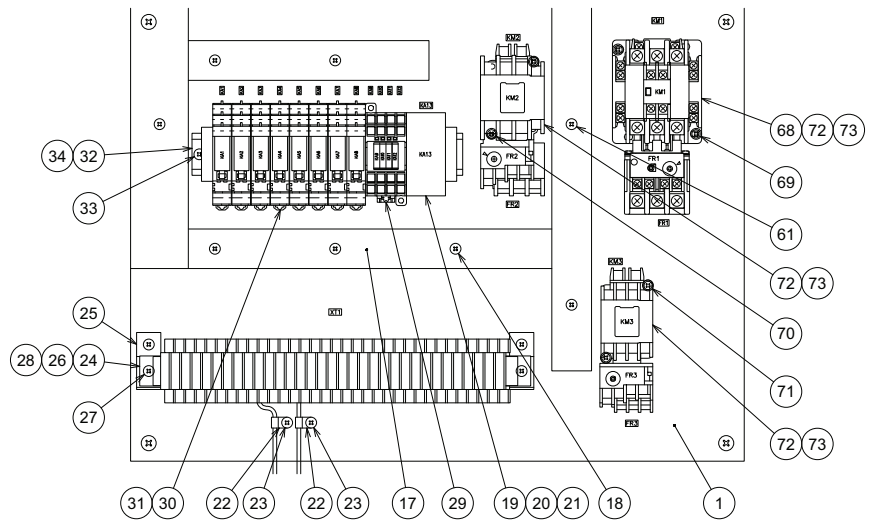
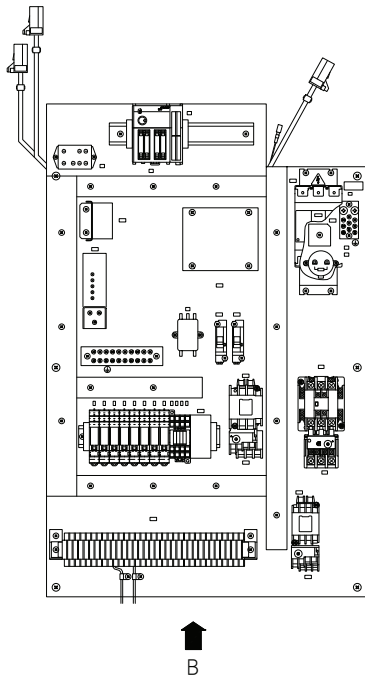

DETAIL B

RB01581--C

Unit No. 70
Electric US(3)

| Index | Code | Parts Name | Drawing No. | Type | Maker | Q'ty | Note |
|-------|----------|---------------------------------|-------------|------------------------------|---------------|------|------|
| 1 | 10301673 | Control Panel | RB00796--C | | | 1 | |
| 2 | 10300833 | Breaker Bracket | RB00782--C | | | 1 | |
| 3 | 10589252 | Sems Pan Head Screw | P334200013 | M4X10(Spring/Polished Round) | JIS | 4 | |
| 4 | 10300195 | Accessory (Low Voltage Breaker) | P812098065 | TCL-05SV3 | MITSUBISHI | 1 | |
| 5 | 10300194 | Accessory (Low Voltage Breaker) | P812098064 | F-05SV | MITSUBISHI | 1 | |
| 6 | 10300207 | Rectifier | P840068014 | KBPC35-10 | SUMGLE | 1 | VC1 |
| 7 | 10589252 | Sems Pan Head Screw | P334200013 | M4X10(Spring/Polished Round) | JIS | 1 | |
| 8 | 10300211 | Aluminum Capacitor | P840108041 | 50V10000Micro Farad | HWAKAI | 1 | C0 |
| 9 | 10300212 | Resistor | P841128056 | RS2W(5.1 kOhm) | YCX | 1 | R0 |
| 10 | 10589250 | Sems Pan Head Screw | P334200010 | M3X10(Spring/Polished Round) | JIS | 2 | |
| 11 | 10300180 | Transformer | P772008054 | JBK5-400 | JUCHE | 1 | TC1 |
| 12 | 10380975 | Sems Pan Head Screw | P334200047 | M5X12(Spring/Polished Round) | JIS | 4 | |
| 13 | 10300196 | Low Voltage Breaker | P812128227 | CP31FS/2D | FUJI Electric | 1 | QF3 |
| 14 | 10380968 | Sems Pan Head Screw | P334200011 | M4X12(Spring/Polished Round) | JIS | 2 | |
| 15 | 10300197 | Low Voltage Breaker | P812128280 | CP31FS/15D | FUJI Electric | 1 | QF2 |
| 16 | 10589252 | Sems Pan Head Screw | P334200013 | M4X10(Spring/Polished Round) | JIS | 2 | |
| 17 | 10301676 | Duct | RB00799--A | | | 1 | |
| 18 | 10589252 | Sems Pan Head Screw | P334200013 | M4X10(Spring/Polished Round) | JIS | 6 | |
| 19 | 10301576 | Control Relay | P800002015 | MY2N-D2-DC24V | OMRON | 1 | KA13 |

Unit No. 70
Electric US(3)

| Index | Code | Parts Name | Drawing No. | Type | Maker | Q'ty | Note |
|-------|----------|---------------------------------|-------------|------------------------------|-------------------|------|--------|
| 20 | 10300215 | Accessory for Connector | P862188020 | PYF08A | OMRON | 1 | |
| 21 | 10349515 | Accessory for Connector | P862188011 | PYC-A1 | OMRON | 1 | |
| 22 | 10579245 | Cable Clamp | P381048008 | EMT-2N | TAKEUCHI Industry | 2 | |
| 23 | 10589252 | Sems Pan Head Screw | P334200013 | M4X10(Spring/Polished Round) | JIS | 2 | |
| 24 | 10301675 | Terminal Block ASSY | RB00798--B | | | 1 | XT1 |
| 25 | 10301117 | Tilting Attachment | RB0160003- | (Conform to) BP23-2S | | 2 | |
| 26 | 10301661 | Written Order (Fixing Resistor) | RB0079407A | | | 1 | |
| 27 | 10589252 | Sems Pan Head Screw | P334200013 | M4X10(Spring/Polished Round) | JIS | 6 | |
| 28 | 10301579 | Resistor | P841128057 | RS5W(470 Ohm) | YCX | 2 | |
| 29 | 10421120 | Control Relay | P800004060 | RS4N-DE | FUJI Electric | 1 | KA9-12 |
| 30 | 10589483 | Control Relay | P800002075 | G2R-1-SND-DC24V | OMRON | 8 | KA1-8 |
| 31 | 10589484 | Accessory for Control Relay | P800082015 | P2RF-05-E | OMRON | 8 | |
| 32 | 10301679 | DIN Rail | RB00803--A | | | 1 | |
| 33 | 10589252 | Sems Pan Head Screw | P334200013 | M4X10(Spring/Polished Round) | JIS | 2 | |
| 34 | 10337281 | Terminal Parts | P864052008 | BNL6 | IDEC | 4 | |
| 35 | 10589252 | Sems Pan Head Screw | P334200013 | M4X10(Spring/Polished Round) | JIS | 2 | |
| 36 | 10337328 | Noise Filter | P840048003 | ZCB2203-11 | TDK | 1 | Z0 |
| 37 | 10589250 | Sems Pan Head Screw | P334200010 | M3X10(Spring/Polished Round) | JIS | 2 | |
| 38 | 10300834 | Ground Bar | RB00783--A | | | 1 | |

Unit No. 70
Electric US(3)

| Index | Code | Parts Name | Drawing No. | Type | Maker | Q'ty | Note |
|-------|----------|---------------------------------|-------------|------------------------------|---------------|------|------|
| 39 | 10380683 | Sems Pan Head Screw | P334200034 | M4X16(Spring/Polished Round) | JIS | 2 | |
| 40 | 10380682 | Sems Pan Head Screw | P334200032 | M4X6(Spring/Polished Round) | JIS | 20 | |
| 41 | 10579233 | Switching Power Supply | P772124027 | JWS50-24/A | DENSEI-LAMBDA | 1 | GS1 |
| 42 | 10579234 | Accessory for Power Supply | P772188003 | L-09 | DENSEI-LAMBDA | 1 | |
| 43 | 10589249 | Sems Pan Head Screw | P334200008 | M3X6(Spring/Polished Round) | JIS | 6 | |
| 44 | 10579235 | Switching Power Supply | P772123024 | LDA10F-12-SN | COSEL | 1 | GS2 |
| 45 | 10589249 | Sems Pan Head Screw | P334200008 | M3X6(Spring/Polished Round) | JIS | 2 | |
| 46 | 10301674 | LDA Power Supply Bracket | RB00797--B | | | 1 | |
| 47 | 10301662 | GS2 Primary Cable | RB0079408A | | | 1 | |
| 48 | 10301663 | GS2 Secondary Cable | RB0079409A | | | 1 | |
| 49 | 10589252 | Sems Pan Head Screw | P334200013 | M4X10(Spring/Polished Round) | JIS | 2 | |
| 50 | 10589252 | Sems Pan Head Screw | P334200013 | M4X10(Spring/Polished Round) | JIS | 3 | |
| 51 | 10301659 | Cable CN50F | RB0079405B | | | 1 | CN50 |
| 52 | 10301660 | Cable CN51F | RB0079406A | | | 1 | CN51 |
| 53 | 10301575 | Programmable Controller | P767406010 | FX3UC-64MT/DSS | MITSUBISHI | 1 | E2 |
| 54 | 10582061 | Accessory (Program Controller) | P767486029 | FX3U-FLROM-64 | MITSUBISHI | 1 | |
| 55 | 10579239 | Accessory (Indicator Apparatus) | P767588010 | D4RVM10 | Diatrend | 1 | |
| 56 | 10301655 | Cable CN1 | RB0079401C | | | 1 | |
| 57 | 10301656 | Cable CN2 | RB0079402A | | | 1 | |

Unit No. 70
Electric US(3)

| Index | Code | Parts Name | Drawing No. | Type | Maker | Q'ty | Note |
|-------|----------|---------------------------|-------------|------------------------------|---------------|------|---------------------------------|
| 58 | 10301657 | Cable CN3 | RB0079403A | | | 1 | CN52 |
| 59 | 10301658 | Cable CN4 | RB0079404B | | | 1 | |
| 60 | 10589252 | Sems Pan Head Screw | P334200013 | M4X10(Spring/Polished Round) | JIS | 2 | |
| 61 | 10589252 | Sems Pan Head Screw | P334200013 | M4X10(Spring/Polished Round) | JIS | 4 | |
| 62 | 10301123 | Charging Mark | RB0160010- | 20MM | | 1 | |
| 63 | 10300835 | Ground Bar | RB00784--A | | | 1 | PE |
| 64 | 10380683 | Sems Pan Head Screw | P334200034 | M4X16(Spring/Polished Round) | JIS | 2 | |
| 65 | 10380682 | Sems Pan Head Screw | P334200032 | M4X6(Spring/Polished Round) | JIS | 9 | |
| 66 | 10300140 | Sems Pan Head Screw | P334200084 | M6X8(Spring/Polished Round) | JIS | 2 | |
| 67 | 10300143 | Washer | P336000074 | 6(Polished Round)T=1.0 | JIS | 2 | |
| 68 | 10589493 | Accessory (Magnet Switch) | P810184001 | SZ-A20 | FUJI Electric | 1 | KM1,FR1 |
| 69 | 10380683 | Sems Pan Head Screw | P334200034 | M4X16(Spring/Polished Round) | JIS | 2 | |
| 70 | 10380683 | Sems Pan Head Screw | P334200034 | M4X16(Spring/Polished Round) | JIS | 2 | |
| 71 | 10380683 | Sems Pan Head Screw | P334200034 | M4X16(Spring/Polished Round) | JIS | 2 | |
| 72 | 10301116 | Spark Killer | RB0160002- | (Conform to) SKVB104120 | | 3 | |
| 73 | 10300210 | Varistor | P840078056 | TUR20D112K | JOCOL | 9 | |
| 74 | 10300214 | Plug Type Terminal | P862148060 | PC-2005F | NICHIFU | 1 | N24A |
| 75 | 10301580 | Insulating Sleeve | P869238018 | OA-BCP5 | OHM Electric | 2 | |
| 76 | 10301079 | Name Plate | RB0154804A | | | 1 | List Only/US(AC230V)/AS(AC460V) |

Unit No. 71
 Electric US(4) <Control Panel>

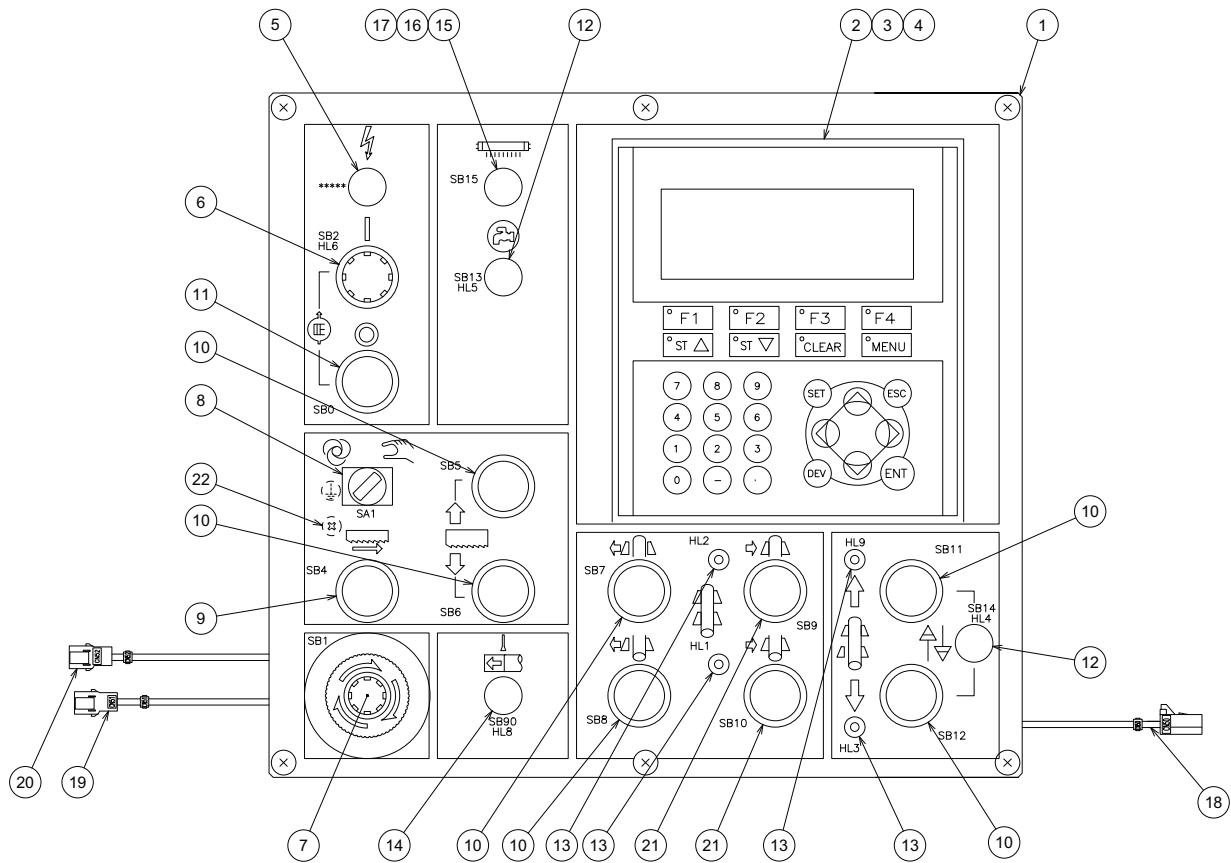

RB00795--B

Unit No. 71
Electric US(4)

| Index | Code | Parts Name | Drawing No. | Type | Maker | Q'ty | Note |
|-------|----------|---------------------------------|-------------|-------------------------|-----------------|------|-----------------|
| 1 | 10301677 | Name Plate | RB00800-B | | | 1 | |
| 2 | 10579261 | Indicator Apparatus | P767508019 | F930GOT-BBD-K | MITSUBISHI | 1 | |
| 3 | 10301678 | F Switch Sheet | RB00801--- | | | 1 | |
| 4 | 10579264 | Accessory (Indicator Apparatus) | P767588011 | F9GT-30PSC | MITSUBISHI | 2 | |
| 5 | 10300213 | Indicator Apparatus | P843024023 | AH165-ZWH3 | FUJI Electric | 1 | HL7 |
| 6 | 10579339 | Push Button Switch (with Lamp) | P822084031 | AR22F0L-10H3W | FUJI Electric | 1 | SB2,HL6 |
| 7 | 10300199 | Push Button Switch | P821084115 | AR22V0R-01R | FUJI Electric | 1 | SB1 |
| 8 | 10337159 | Key Select Switch | P820004027 | AH165-P2B11 | FUJI Electric | 1 | SA1 |
| 9 | 10579341 | Push Button Switch | P821084154 | AR22G2R-20W | FUJI Electric | 1 | SB4 |
| 10 | 10589510 | Push Button Switch | P821084080 | AR22F0R-10W | FUJI Electric | 6 | SB5,6,7,8,11,12 |
| 11 | 10300198 | Push Button Switch | P821084081 | AR22F0R-01B | FUJI Electric | 1 | SB0 |
| 12 | 10300204 | Push Button Switch (with Lamp) | P822064076 | AH165-L5W11E3 | FUJI Electric | 2 | SB13,14,HL4,5 |
| 13 | 10583452 | Indicator Apparatus | P843188016 | DB24-89WUS | MARUYASU DENGYO | 4 | HL1,2,3,9 |
| 14 | 10578823 | Blind Plug | P229138005 | AHX622-B | FUJI Electric | 1 | SB90,HL8 |
| 15 | 10337521 | Push Button Switch | P821064009 | AH165-E5W22 | FUJI Electric | 1 | SB15 |
| 16 | 10300208 | Varistor | P840078053 | TUR20D271K | JOCOL | 1 | |
| 17 | 10301116 | Spark Killer | RB0160002- | (Conform to) SKVB104120 | | 1 | |
| 18 | 10301670 | Cable (50m) | RB0079501A | | | 1 | CN50 |
| 19 | 10301671 | Cable (51m) | RB0079502A | | | 1 | CN51 |

Unit No. 71
Electric US(4)

| Index | Code | Parts Name | Drawing No. | Type | Maker | Q'ty | Note |
|-------|----------|---------------------|-------------|------------------------------|---------------|------|--------|
| 20 | 10301672 | Cable (52m) | RB0079503A | | | 1 | CN52 |
| 21 | 10300200 | Push Button Switch | P821084195 | AR22G2R-10W | FUJI Electric | 2 | SB9,10 |
| 22 | 10589252 | Sems Pan Head Screw | P334200013 | M4X10(Spring/Polished Round) | JIS | 1 | |

Unit No. 72
Electric US(5)-1/2 <US Specification Component>

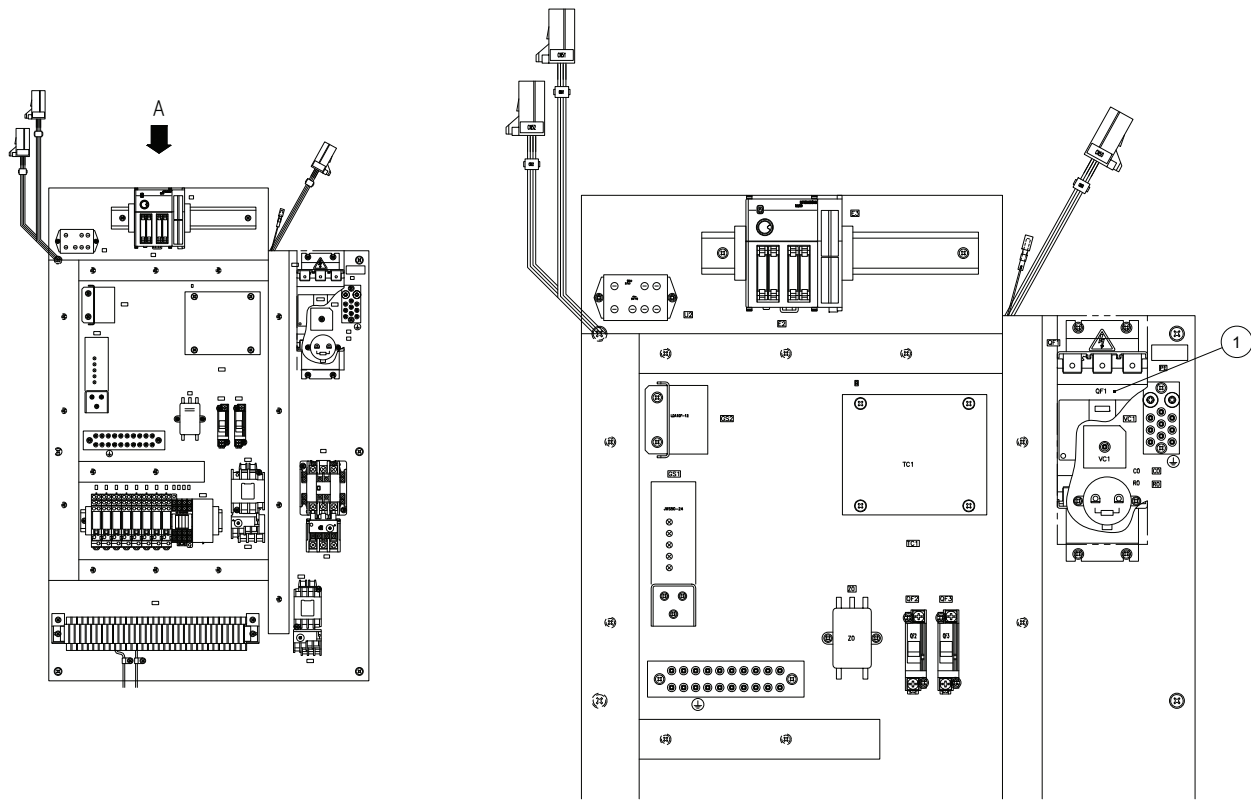

DETAIL A

RB01574---
(RB01581--C)

Unit No. 72
 Electric US(5)-2/2 <US Specification Component>

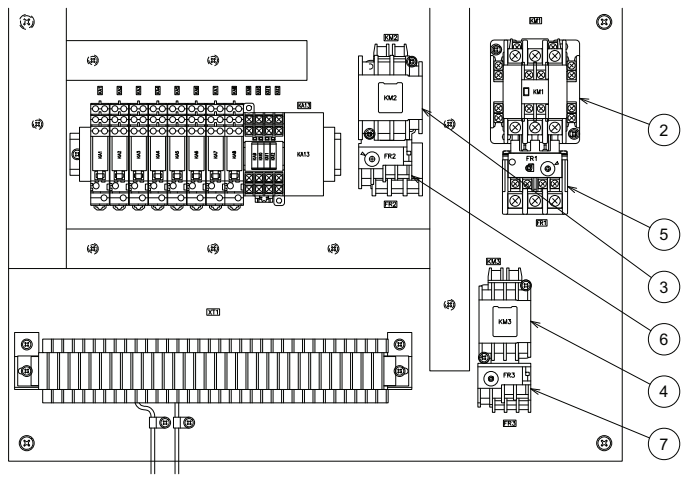
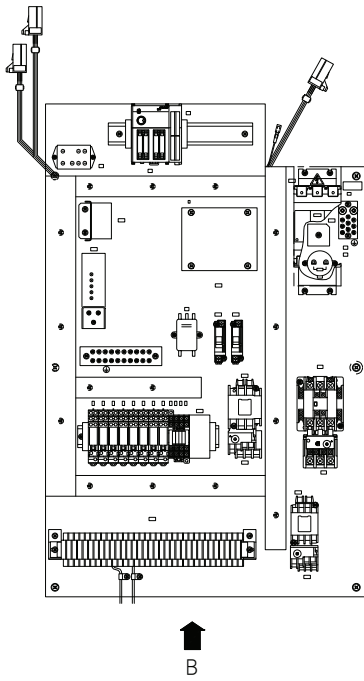

DETAIL B

RB01574---
 (RB01581--C)

Unit No. 72
Electric US(5)

| Index | Code | Parts Name | Drawing No. | Type | Maker | Q'ty | Note |
|-------|----------|---------------------|-------------|-----------------------|---------------|------|----------------|
| 1 | 10301310 | Low Voltage Breaker | P812008031 | NF125-CVF-3P-75A | MITSUBISHI | 1 | for 230V / QF1 |
| 1 | 10300187 | Low Voltage Breaker | P812008026 | NF32-SV-3P-30A | MITSUBISHI | 1 | for 460V / QF1 |
| 2 | 10579414 | Magnet Switch | P810044149 | SW-N1/3H(18A)AC100V | FUJI Electric | 1 | KM1 |
| 3 | 10579403 | Magnet Switch | P810044143 | SW-05/3H(5A)AC100V-2A | FUJI Electric | 1 | KM2 |
| 4 | 10579406 | Magnet Switch | P810044144 | SW-0/3H(0.48A)AC100V | FUJI Electric | 1 | KM3 |
| 5 | 10579411 | Protection Relay | P801004110 | TR-N2/3(7-11A) | FUJI Electric | 1 | for 460V / FR1 |
| 6 | 10301307 | Protection Relay | P801004149 | TR-0N/3(2.2-3.4A) | FUJI Electric | 1 | for 460V / FR2 |
| 7 | 10301306 | Protection Relay | P801004148 | TR-0N/3(0.3-0.45A) | FUJI Electric | 1 | for 460V / FR3 |

Unit No. 73
Electric EU(1)

| Index | Code | Parts Name | Drawing No. | Type | Maker | Q'ty | Note |
|-------|----------|-----------------------------------|-------------|------|-------|------|------|
| 1 | 10301332 | Saw Blade Motor Cable | RB0153801A | | | 1 | |
| 2 | 10301333 | Hydraulic Motor Cable | RB0153802A | | | 1 | |
| 3 | 10301334 | Cutting Fluid Pump Motor Cable | RB0153803A | | | 1 | |
| 4 | 10301957 | Proportional Valve Cable (Power) | RB0153804A | | | 1 | |
| 5 | 10301958 | Proportional Valve Cable (Signal) | RB0153805B | | | 1 | |
| 6 | 10301959 | Rase/Lower SOL Cable | RB0153806A | | | 1 | |
| 7 | 10301960 | Front Vise SOL Cable | RB0153808A | | | 1 | |
| 8 | 10301961 | Rear Vise SOL Cable | RB0153809A | | | 1 | |
| 9 | 10301779 | Work Feeding ENC Cable | RB0152310A | | | 1 | |
| 10 | 10301962 | Sawhead Upper Limit LS Cable | RB0153811A | | | 1 | |
| 11 | 10301963 | Lower Limit LS Cable | RB0153812A | | | 1 | |
| 12 | 10301964 | Forward Limit LS Cable | RB0153814A | | | 1 | |
| 13 | 10301965 | Blade Break LS Cable | RB0153815A | | | 1 | |
| 14 | 10301981 | Cover Open Limit Switch Cable | RB0157216B | | | 1 | |
| 15 | 10301784 | Front/Rear Vise Close LS Cable | RB0152317B | | | 1 | |
| 16 | 10301966 | LS Cable | RB0153819A | | | 1 | |
| 17 | 10301967 | AMD Motion Detector Cable | RB0153820A | | | 1 | |
| 18 | 10301968 | AMD Junction Cable | RB0153821A | | | 1 | |
| 19 | 10301969 | Housing Junction Cable 1 | RB0153822A | | | 1 | |

Unit No. 73
Electric EU(1)

| Index | Code | Parts Name | Drawing No. | Type | Maker | Q'ty | Note |
|-------|----------|---------------------------------|-------------|------|-------|------|------|
| 20 | 10301970 | Working Light Cable | RB0153823A | | | 1 | |
| 21 | 10301971 | Working Light Junction Cable | RB0153824A | | | 1 | |
| 22 | 10301973 | Housing Junction Cable 2 | RB0153826A | | | 1 | |
| 23 | 10301982 | Emergency Stop Button Cable | RB0157227A | | | 1 | |
| 24 | 10301983 | Cutting Fluid Level Gauge Cable | RB0157228- | | | 1 | |

Unit No. 74
 Electric EU(2)-1/2 <Electrical Enclosure>

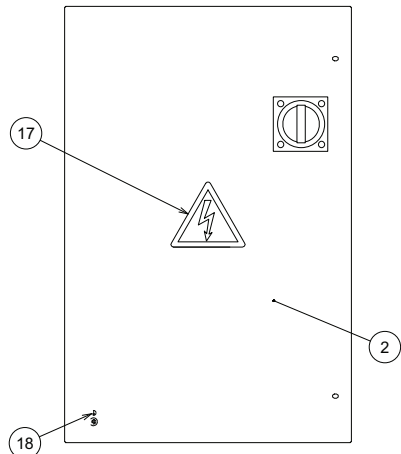
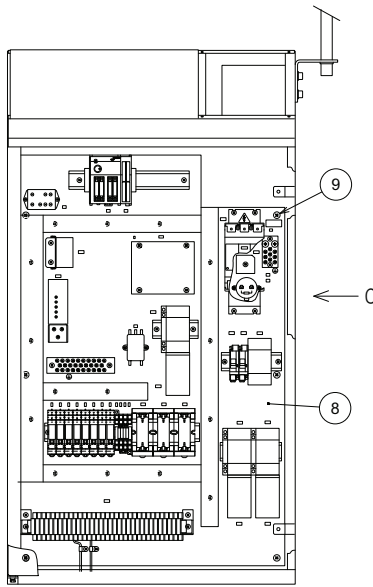
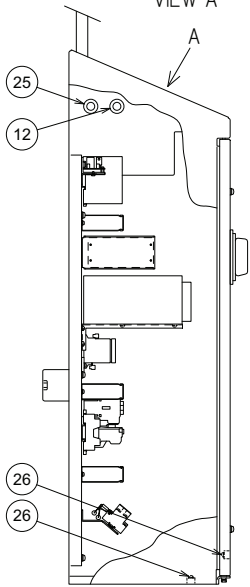
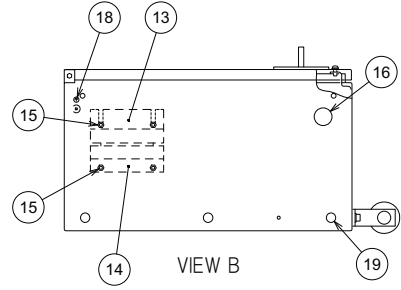
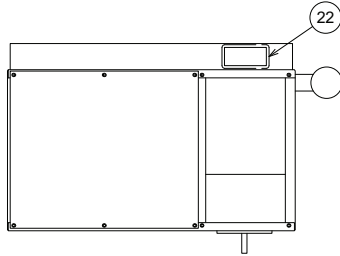
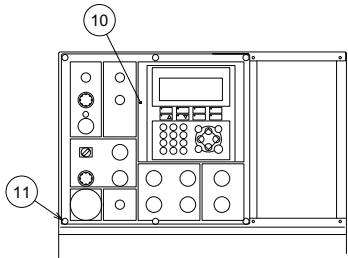

B

RB01573--C

Unit No. 74
 Electric EU(2)-2/2 <Electrical Enclosure>

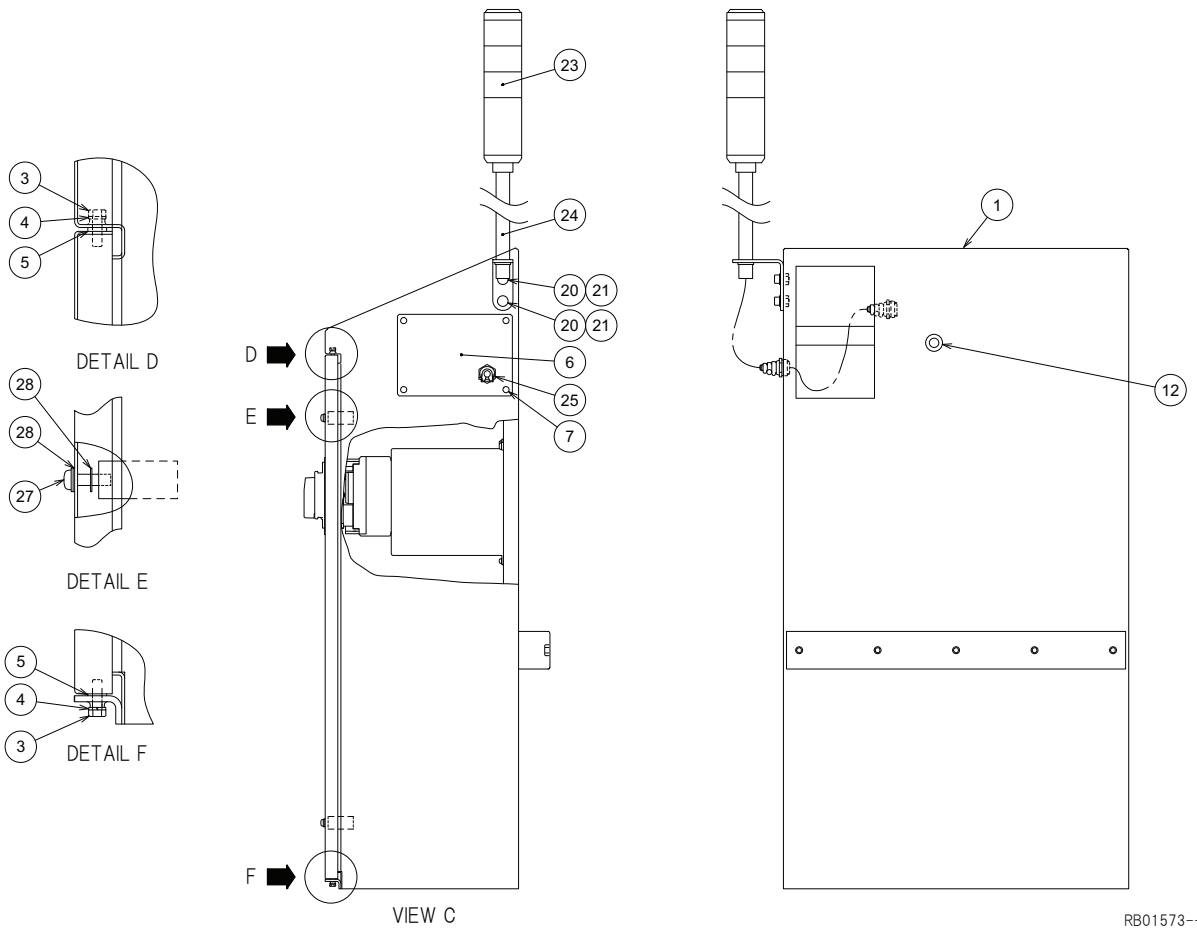

RB01573--C

Unit No. 74
Electric EU(2)

| Index | Code | Parts Name | Drawing No. | Type | Maker | Q'ty | Note |
|-------|----------|---------------------|-------------|------------------------------|-------|------|------|
| 1 | 10300821 | Control Box | RB00774--C | | | 1 | |
| 2 | 10300822 | Control Box Cover | RB00775--B | | | 1 | |
| 3 | 10325830 | Bolt | P330010005 | M5X16 | JIS | 2 | |
| 4 | 10322215 | Spring Washer | P336050004 | 5 | JIS | 2 | |
| 5 | 10323127 | Washer | P336000059 | 5(Polished Round) | JIS | 2 | |
| 6 | 10300824 | Cover | RB00776--B | | | 1 | |
| 7 | 10322224 | Pan Head Screw | P334100039 | M5X10 | JIS | 4 | |
| 8 | 10301988 | Panel Arrangement | RB01580--C | | | 1 | |
| 9 | 10325313 | Pan Head Screw | P334100058 | M6X16 | JIS | 6 | |
| 10 | 10301669 | Control Panel | RB00795--B | | | 1 | |
| 11 | 10372307 | Truss Head Screw | P334130009 | M5X12 | JIS | 6 | |
| 12 | 10301115 | Bush for Cable | RB0160001- | D22 | | 2 | |
| 13 | 10300830 | Cable Retainer A | RB00779--B | | | 1 | |
| 14 | 10300831 | Cable Retainer B | RB00780--B | | | 1 | |
| 15 | 10380944 | Sems Pan Head Screw | P334200063 | M6X16(Spring/Polished Round) | JIS | 4 | |
| 16 | 10301119 | CAPCON | RB0160006- | D34 | | 1 | |
| 17 | 10301069 | Charging Mark D | RB01517--- | 125MM | | 1 | |
| 18 | 10301068 | Sticker (Ground) | RB01516--- | | | 1 | |
| 19 | 10301120 | Grommet | RB0160007- | D18 | | 1 | |

Unit No. 74
Electric EU(2)

| Index | Code | Parts Name | Drawing No. | Type | Maker | Q'ty | Note |
|-------|----------|---------------------------------|-------------|------------------------------|-----------|------|------|
| 20 | 10321923 | Washer | P336000006 | 8(Normal) | JIS | 2 | |
| 21 | 10342325 | Hex Socket Cap Screw | P330230004 | M8X15 | | 2 | |
| 22 | 10301121 | Grommet | RB0160008- | W4XL250 | | 1 | |
| 23 | 10579311 | Signal Light Unit | P642142046 | LME-302W-RYG | PATLITE | 1 | |
| 24 | 10579313 | Accessory for Signal Light Unit | P642178006 | SZ-70L(640MM) | PATLITE | 1 | |
| 25 | 10301122 | CAPCON | RB0160009- | OA-1 | | 2 | |
| 26 | 10589252 | Sems Pan Head Screw | P334200013 | M4X10(Spring/Polished Round) | JIS | 2 | |
| 27 | 10322133 | Truss Head Screw | P334130014 | M6X20 | JIS | 2 | |
| 28 | 10380967 | Washer | P336198002 | TM-147-4 | TOCHIGIYA | 4 | |

Unit No. 75
 Electric EU(3)-1/2 <Panel Arrangement>

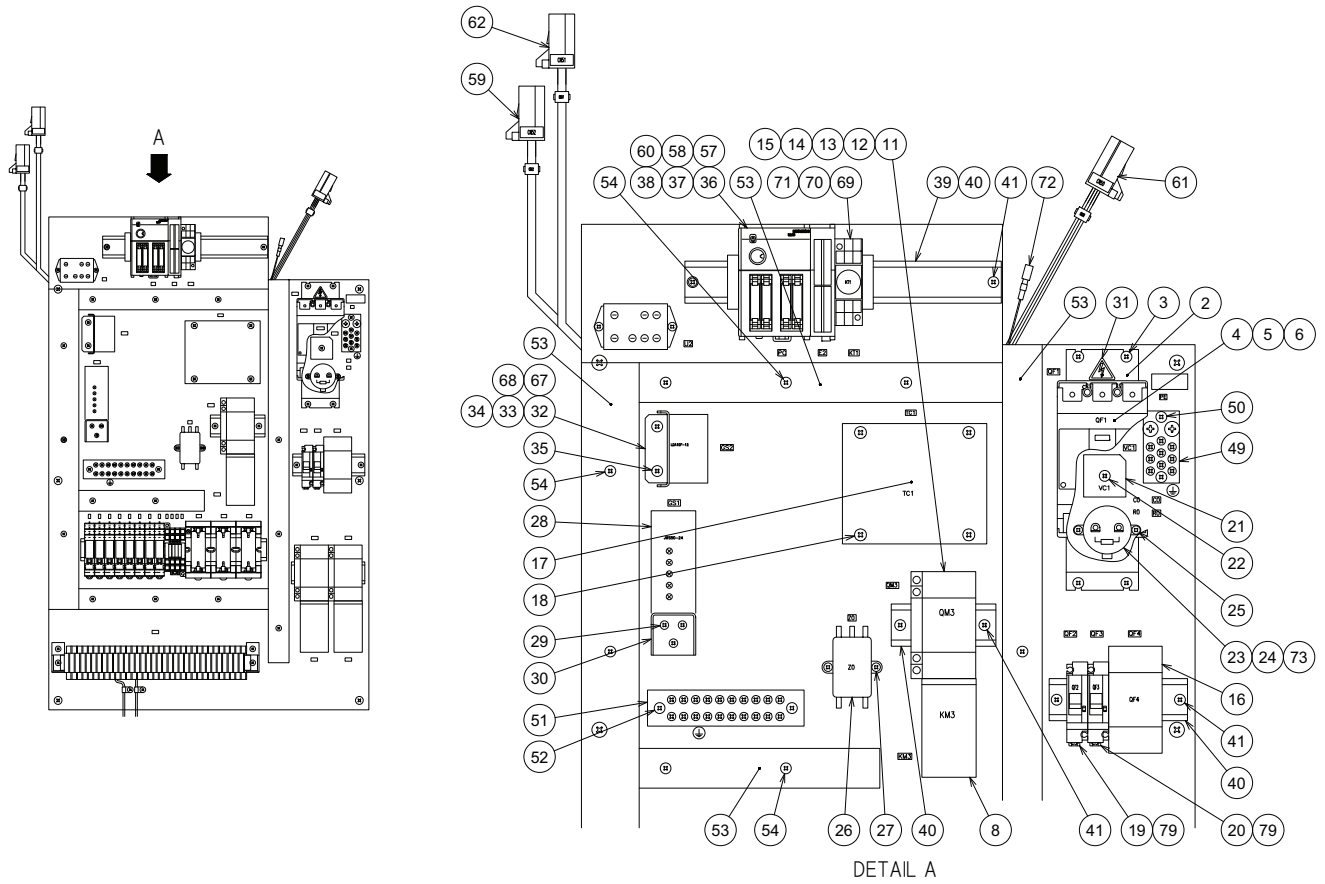

Unit No. 75
 Electric EU(3)-2/2 <Panel Arrangement>

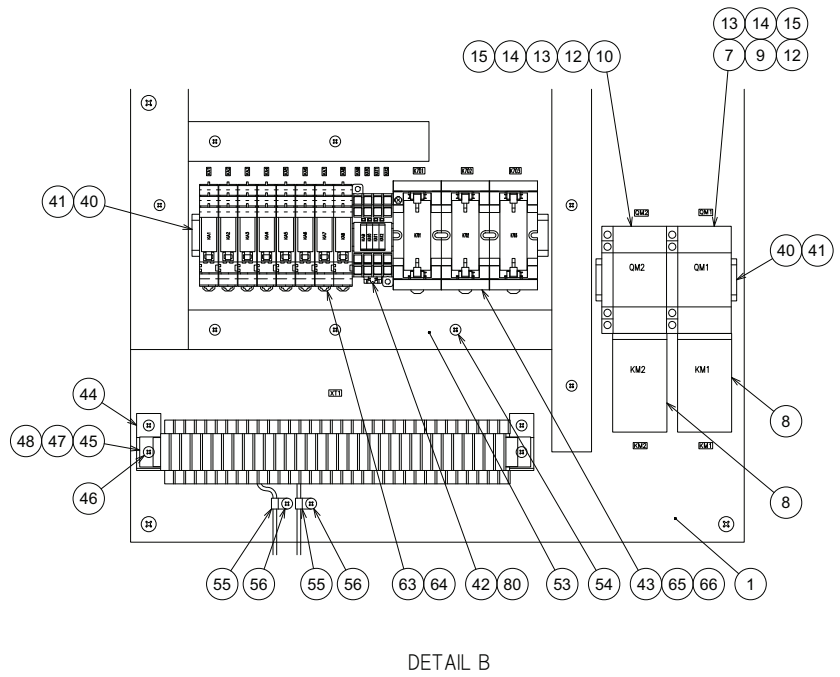
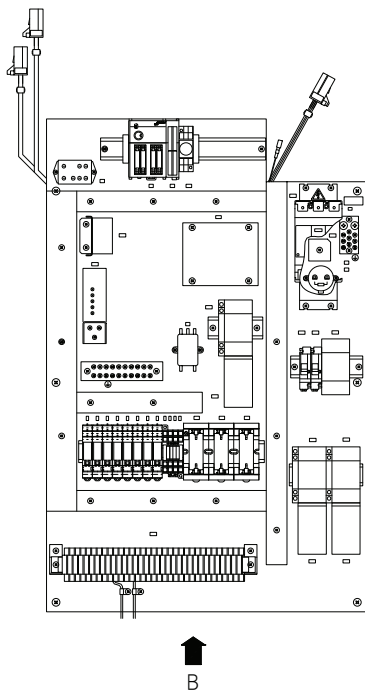

Unit No. 75
Electric EU(3)

| Index | Code | Parts Name | Drawing No. | Type | Maker | Q'ty | Note |
|-------|----------|---------------------------------|-------------|------------------------------|--------------------|------|-------|
| 1 | 10301673 | Control Panel | RB00796--C | | | 1 | |
| 2 | 10300833 | Breaker Bracket | RB00782--C | | | 1 | |
| 3 | 10589252 | Sems Pan Head Screw | P334200013 | M4X10(Spring/Polished Round) | JIS | 4 | |
| 4 | 10300187 | Low Voltage Breaker | P812008026 | NF32-SV-3P-30A | MITSUBISHI | 1 | QF1 |
| 5 | 10300195 | Accessory (Low Voltage Breaker) | P812098065 | TCL-05SV3 | MITSUBISHI | 1 | |
| 6 | 10300194 | Accessory (Low Voltage Breaker) | P812098064 | F-05SV | MITSUBISHI | 1 | |
| 7 | 10301311 | Low Voltage Breaker | P812048100 | GV2-ME166 | Schneider Electric | 1 | QM1 |
| 8 | 10579225 | Magnet Contactor | P810008012 | LC1-D12K7 | Schneider Electric | 1 | KM1-3 |
| 9 | 10300184 | Accessory for Contactor | P810018016 | LAD-N31 | Schneider Electric | 1 | |
| 10 | 10589731 | Low Voltage Breaker | P812048086 | GV2-ME086 | Schneider Electric | 1 | QM2 |
| 11 | 10589498 | Low Voltage Breaker | P812048090 | GV2-ME046 | Schneider Electric | 1 | QM3 |
| 12 | 10579228 | Accessory (Low Voltage Breaker) | P812098024 | GV-AN11 | Schneider Electric | 3 | |
| 13 | 10579229 | Accessory for Contactor | P810018004 | GV2-AF3 | Schneider Electric | 3 | |
| 14 | 10301116 | Spark Killer | RB0160002- | (Conform to) SKVB104120 | | 3 | |
| 15 | 10300210 | Varistor | P840078056 | TUR20D112K | JOCOL | 9 | |
| 16 | 10300192 | Low Voltage Breaker | P812048093 | GV2-ME076 | Schneider Electric | 1 | QF4 |
| 17 | 10300180 | Transformer | P772008054 | JBK5-400 | JUCHE | 1 | TC1 |
| 18 | 10380975 | Sems Pan Head Screw | P334200047 | M5X12(Spring/Polished Round) | JIS | 4 | |
| 19 | 10300197 | Low Voltage Breaker | P812128280 | CP31FS/15D | FUJI Electric | 1 | QF2 |

Unit No. 75
Electric EU(3)

| Index | Code | Parts Name | Drawing No. | Type | Maker | Q'ty | Note |
|-------|----------|---------------------------------|-------------|------------------------------|---------------|------|------|
| 20 | 10300196 | Low Voltage Breaker | P812128227 | CP31FS/2D | FUJI Electric | 1 | QF3 |
| 21 | 10300207 | Rectifier | P840068014 | KBPC35-10 | SUMGLE | 1 | VC1 |
| 22 | 10589252 | Sems Pan Head Screw | P334200013 | M4X10(Spring/Polished Round) | JIS | 1 | |
| 23 | 10300211 | Aluminum Capacitor | P840108041 | 50V10000Micro Farad | HWAKAI | 1 | C0 |
| 24 | 10300212 | Resistor | P841128056 | RS2W(5.1 kOhm) | YCX | 1 | R0 |
| 25 | 10589250 | Sems Pan Head Screw | P334200010 | M3X10(Spring/Polished Round) | JIS | 2 | |
| 26 | 10337328 | Noise Filter | P840048003 | ZCB2203-11 | TDK | 1 | Z0 |
| 27 | 10589250 | Sems Pan Head Screw | P334200010 | M3X10(Spring/Polished Round) | JIS | 2 | |
| 28 | 10579233 | Switching Power Supply | P772124027 | JWS50-24/A | DENSEI-LAMBDA | 1 | GS1 |
| 29 | 10589249 | Sems Pan Head Screw | P334200008 | M3X6(Spring/Polished Round) | JIS | 3 | |
| 30 | 10579234 | Accessory for Power Supply | P772188003 | L-09 | DENSEI-LAMBDA | 1 | |
| 31 | 10589314 | Charging Mark | P360208002 | 20MM | NIKKOUKAI | 1 | |
| 32 | 10579235 | Switching Power Supply | P772123024 | LDA10F-12-SN | COSEL | 1 | GS2 |
| 33 | 10589249 | Sems Pan Head Screw | P334200008 | M3X6(Spring/Polished Round) | JIS | 2 | |
| 34 | 10301674 | LDA Power Supply Bracket | RB00797--B | | | 1 | |
| 35 | 10589252 | Sems Pan Head Screw | P334200013 | M4X10(Spring/Polished Round) | JIS | 2 | |
| 36 | 10301575 | Programmable Controller | P767406010 | FX3UC-64MT/DSS | MITSUBISHI | 1 | PC |
| 37 | 10582061 | Accessory (Program Controller) | P767486029 | FX3U-FLROM-64 | MITSUBISHI | 1 | |
| 38 | 10579239 | Accessory (Indicator Apparatus) | P767588010 | D4RVM10 | Diatrend | 1 | |

Unit No. 75
Electric EU(3)

| Index | Code | Parts Name | Drawing No. | Type | Maker | Q'ty | Note |
|-------|----------|---------------------------------|-------------|------------------------------|-------------------|------|--------|
| 39 | 10337281 | Terminal Parts | P864052008 | BNL6 | IDEC | 2 | |
| 40 | 10301813 | DIN Rail | RB01545--- | | | 1 | |
| 41 | 10589252 | Sems Pan Head Screw | P334200013 | M4X10(Spring/Polished Round) | JIS | 10 | |
| 42 | 10421120 | Control Relay | P800004060 | RS4N-DE | FUJI Electric | 1 | KA9-12 |
| 43 | 10485351 | Accessory for Control Relay | P800082063 | P7S-14F-END | OMRON | 3 | |
| 44 | 10301117 | Tilting Attachment | RB0160003- | (Conform to) BP23-2S | | 2 | |
| 45 | 10301675 | Terminal Block ASSY | RB00798--B | | | 1 | XT1 |
| 46 | 10589252 | Sems Pan Head Screw | P334200013 | M4X10(Spring/Polished Round) | JIS | 4 | |
| 47 | 10301579 | Resistor | P841128057 | RS5W(470 Ohm) | YCX | 2 | |
| 48 | 10301661 | Written Order (Fixing Resistor) | RB0079407A | | | 1 | |
| 49 | 10300835 | Ground Bar | RB00784--A | | | 1 | PE |
| 50 | 10380683 | Sems Pan Head Screw | P334200034 | M4X16(Spring/Polished Round) | JIS | 2 | |
| 51 | 10301799 | Ground Bar | RB01528--- | | | 1 | |
| 52 | 10380683 | Sems Pan Head Screw | P334200034 | M4X16(Spring/Polished Round) | JIS | 2 | |
| 53 | 10301676 | Duct | RB00799--A | | | 1 | |
| 54 | 10589252 | Sems Pan Head Screw | P334200013 | M4X10(Spring/Polished Round) | JIS | 15 | |
| 55 | 10579245 | Cable Clamp | P381048008 | EMT-2N | TAKEUCHI Industry | 2 | |
| 56 | 10589252 | Sems Pan Head Screw | P334200013 | M4X10(Spring/Polished Round) | JIS | 2 | |
| 57 | 10301655 | Cable CN1 | RB0079401C | | | 1 | |

Unit No. 75
Electric EU(3)

| Index | Code | Parts Name | Drawing No. | Type | Maker | Q'ty | Note |
|-------|----------|-----------------------------|-------------|-----------------------------|--------------|------|-----------|
| 58 | 10301656 | Cable CN2 | RB0079402A | | | 1 | |
| 59 | 10301657 | Cable CN3 | RB0079403A | | | 1 | CN52 |
| 60 | 10301658 | Cable CN4 | RB0079404B | | | 1 | |
| 61 | 10301659 | Cable CN50F | RB0079405B | | | 1 | CN50 |
| 62 | 10301660 | Cable CN51F | RB0079406A | | | 1 | CN51 |
| 63 | 10589483 | Control Relay | P800002075 | G2R-1-SND-DC24V | OMRON | 8 | KA1-8 |
| 64 | 10589484 | Accessory for Control Relay | P800082015 | P2RF-05-E | OMRON | 8 | |
| 65 | 10485349 | Control Relay | P800002125 | G7S-4A2B-E | OMRON | 2 | K701-703 |
| 66 | 10485350 | Control Relay | P800002126 | G7S-3A3B-E | OMRON | 1 | K701-703 |
| 67 | 10301662 | GS2 Primary Cable | RB0079408A | | | 1 | |
| 68 | 10301663 | GS2 Secondary Cable | RB0079409A | | | 1 | |
| 69 | 10301308 | Timer | P805002025 | H3Y-2-DC24V-30SEC | OMRON | 1 | KT1 |
| 70 | 10300215 | Accessory for Connector | P862188020 | PYF08A | OMRON | 1 | |
| 71 | 10301313 | Accessory for Connector | P862188017 | Y92H-3 | OMRON | 1 | |
| 72 | 10300214 | Plug Type Terminal | P862148060 | PC-2005F | NICHIFU | 1 | N24A |
| 73 | 10301580 | Insulating Sleeve | P869238018 | OA-BCP5 | OHM Electric | 2 | |
| 74 | 10380682 | Sems Pan Head Screw | P334200032 | M4X6(Spring/Polished Round) | JIS | 20 | List Only |
| 75 | 10380682 | Sems Pan Head Screw | P334200032 | M4X6(Spring/Polished Round) | JIS | 9 | List Only |
| 76 | 10300140 | Sems Pan Head Screw | P334200084 | M6X8(Spring/Polished Round) | JIS | 2 | List Only |

Unit No. 75
Electric EU(3)

| Index | Code | Parts Name | Drawing No. | Type | Maker | Q'ty | Note |
|-------|----------|---------------------------------|-------------|------------------------|---------------|------|-----------|
| 77 | 10300143 | Washer | P336000074 | 6(Polished Round)T=1.0 | JIS | 2 | List Only |
| 78 | 10301079 | Name Plate | RB0154804A | | | 1 | List Only |
| 79 | 10589507 | Accessory (Low Voltage Breaker) | P812194011 | CP-T4 (Terminal Cover) | FUJI Electric | 4 | |
| 80 | 10429040 | Accessory for Control Relay | P800084018 | RZ4N | FUJI Electric | 1 | |

Unit No. 76
 Electric EU(4) <Control Panel>

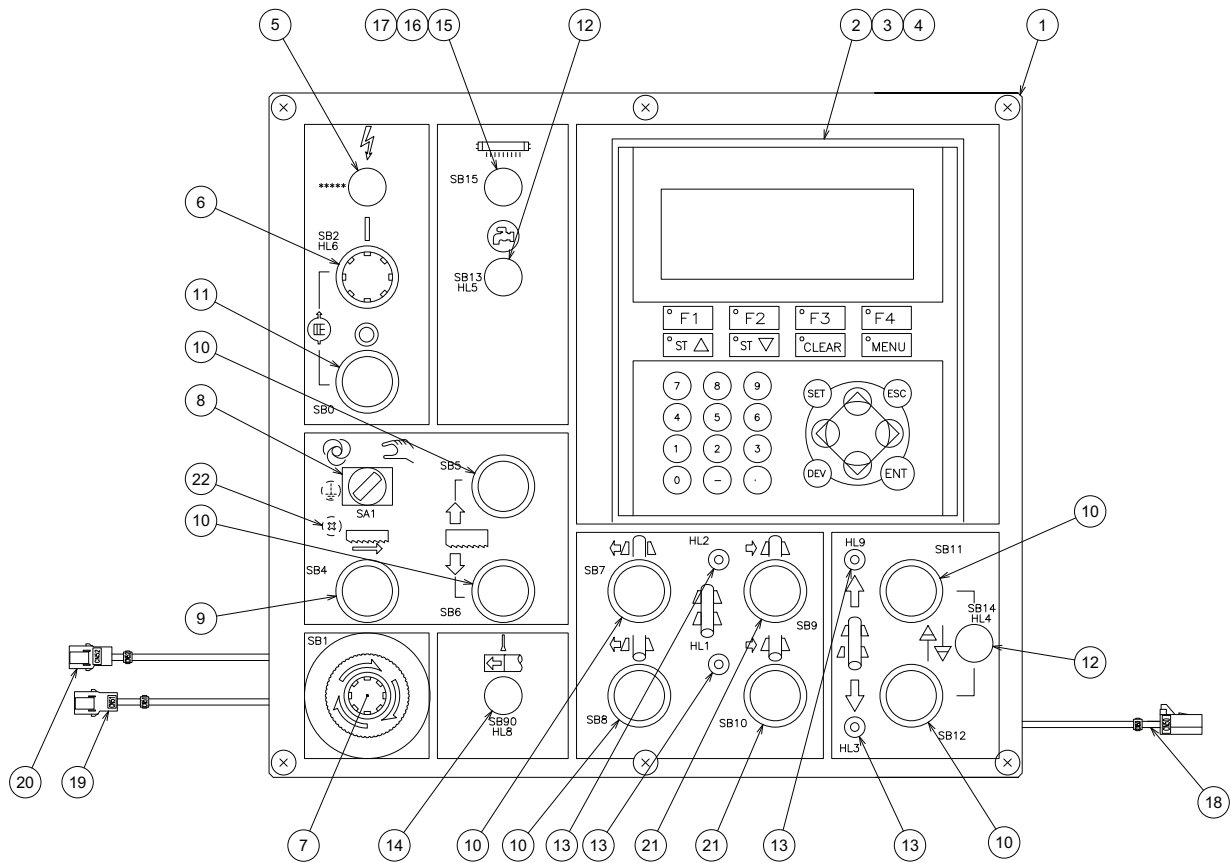

RB00795--B

Unit No. 76
Electric EU(4)

| Index | Code | Parts Name | Drawing No. | Type | Maker | Q'ty | Note |
|-------|----------|---------------------------------|-------------|-------------------------|-----------------|------|-----------------|
| 1 | 10301677 | Name Plate | RB00800-B | | | 1 | |
| 2 | 10579261 | Indicator Apparatus | P767508019 | F930GOT-BBD-K | MITSUBISHI | 1 | |
| 3 | 10301678 | F Switch Sheet | RB00801--- | | | 1 | |
| 4 | 10579264 | Accessory (Indicator Apparatus) | P767588011 | F9GT-30PSC | MITSUBISHI | 2 | |
| 5 | 10300213 | Indicator Apparatus | P843024023 | AH165-ZWH3 | FUJI Electric | 1 | HL7 |
| 6 | 10579339 | Push Button Switch (with Lamp) | P822084031 | AR22F0L-10H3W | FUJI Electric | 1 | SB2,HL6 |
| 7 | 10300199 | Push Button Switch | P821084115 | AR22V0R-01R | FUJI Electric | 1 | SB1 |
| 8 | 10337159 | Key Select Switch | P820004027 | AH165-P2B11 | FUJI Electric | 1 | SA1 |
| 9 | 10579341 | Push Button Switch | P821084154 | AR22G2R-20W | FUJI Electric | 1 | SB4 |
| 10 | 10589510 | Push Button Switch | P821084080 | AR22F0R-10W | FUJI Electric | 6 | SB5,6,7,8,11,12 |
| 11 | 10300198 | Push Button Switch | P821084081 | AR22F0R-01B | FUJI Electric | 1 | SB0 |
| 12 | 10300204 | Push Button Switch (with Lamp) | P822064076 | AH165-L5W11E3 | FUJI Electric | 2 | SB13,14,HL4,5 |
| 13 | 10583452 | Indicator Apparatus | P843188016 | DB24-89WUS | MARUYASU DENGYO | 4 | HL1,2,3,9 |
| 14 | 10578823 | Blind Plug | P229138005 | AHX622-B | FUJI Electric | 1 | SB90,HL8 |
| 15 | 10337521 | Push Button Switch | P821064009 | AH165-E5W22 | FUJI Electric | 1 | SB15 |
| 16 | 10300208 | Varistor | P840078053 | TUR20D271K | JOCOL | 1 | |
| 17 | 10301116 | Spark Killer | RB0160002- | (Conform to) SKVB104120 | | 1 | |
| 18 | 10301670 | Cable (50m) | RB0079501A | | | 1 | CN50 |
| 19 | 10301671 | Cable (51m) | RB0079502A | | | 1 | CN51 |

Unit No. 76
Electric EU(4)

| Index | Code | Parts Name | Drawing No. | Type | Maker | Q'ty | Note |
|-------|----------|---------------------|-------------|------------------------------|---------------|------|--------|
| 20 | 10301672 | Cable (52m) | RB0079503A | | | 1 | CN52 |
| 21 | 10300200 | Push Button Switch | P821084195 | AR22G2R-10W | FUJI Electric | 2 | SB9,10 |
| 22 | 10589252 | Sems Pan Head Screw | P334200013 | M4X10(Spring/Polished Round) | JIS | 1 | |

Unit No. 77
Electric AS(1)

| Index | Code | Parts Name | Drawing No. | Type | Maker | Q'ty | Note |
|-------|----------|-----------------------------------|-------------|------|-------|------|------|
| 1 | 10301332 | Saw Blade Motor Cable | RB0153801A | | | 1 | |
| 2 | 10301333 | Hydraulic Motor Cable | RB0153802A | | | 1 | |
| 3 | 10301334 | Cutting Fluid Pump Motor Cable | RB0153803A | | | 1 | |
| 4 | 10301957 | Proportional Valve Cable (Power) | RB0153804A | | | 1 | |
| 5 | 10301958 | Proportional Valve Cable (Signal) | RB0153805B | | | 1 | |
| 6 | 10301959 | Rase/Lower SOL Cable | RB0153806A | | | 1 | |
| 7 | 10301960 | Front Vise SOL Cable | RB0153808A | | | 1 | |
| 8 | 10301961 | Rear Vise SOL Cable | RB0153809A | | | 1 | |
| 9 | 10301779 | Work Feeding ENC Cable | RB0152310A | | | 1 | |
| 10 | 10301962 | Sawhead Upper Limit LS Cable | RB0153811A | | | 1 | |
| 11 | 10301963 | Lower Limit LS Cable | RB0153812A | | | 1 | |
| 12 | 10301964 | Forward Limit LS Cable | RB0153814A | | | 1 | |
| 13 | 10301965 | Blade Break LS Cable | RB0153815A | | | 1 | |
| 14 | 10301784 | Front/Rear Vise Close LS Cable | RB0152317B | | | 1 | |
| 15 | 10301966 | LS Cable | RB0153819A | | | 1 | |
| 16 | 10301967 | AMD Motion Detector Cable | RB0153820A | | | 1 | |
| 17 | 10301968 | AMD Junction Cable | RB0153821A | | | 1 | |
| 18 | 10301969 | Housing Junction Cable 1 | RB0153822A | | | 1 | |
| 19 | 10301970 | Working Light Cable | RB0153823A | | | 1 | |

Unit No. 77
Electric AS(1)

| Index | Code | Parts Name | Drawing No. | Type | Maker | Q'ty | Note |
|-------|----------|-------------------------------|-------------|------|-------|------|------|
| 20 | 10301971 | Working Light Junction Cable | RB0153824A | | | 1 | |
| 21 | 10301972 | Cover Open Limit Switch Cable | RB0153825B | | | 1 | |
| 22 | 10301973 | Housing Junction Cable 2 | RB0153826A | | | 1 | |

Unit No. 78
 Electric AS(2)-1/2 <Electrical Enclosure>

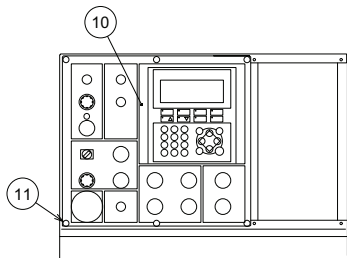

VIEW A

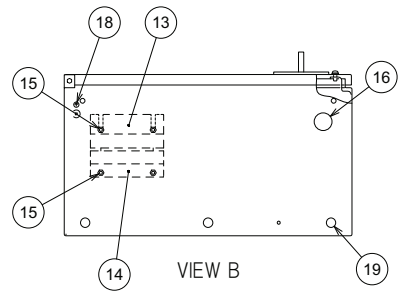
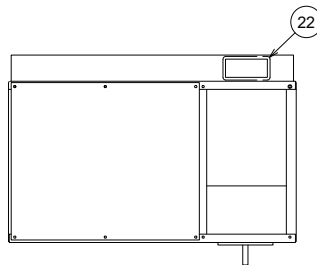

VIEW B

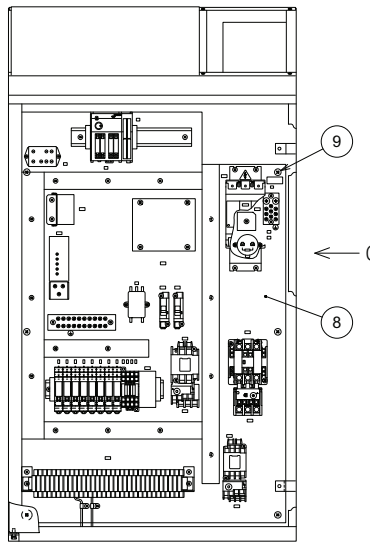
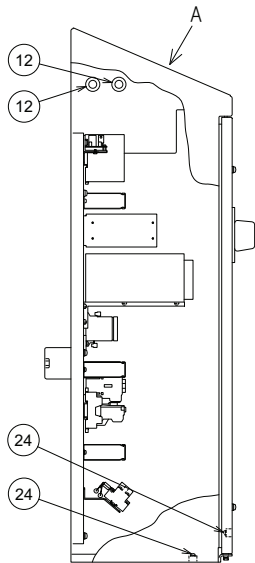

B

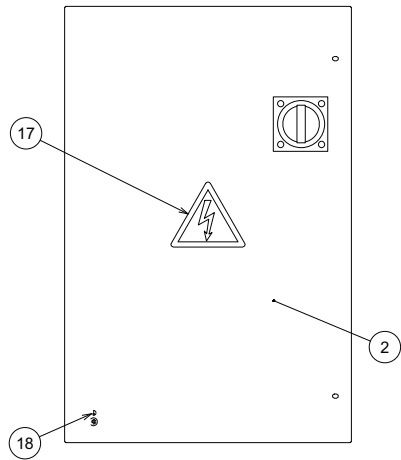

RB01539--C

Unit No. 78
Electric AS(2)-2/2 <Electrical Enclosure>

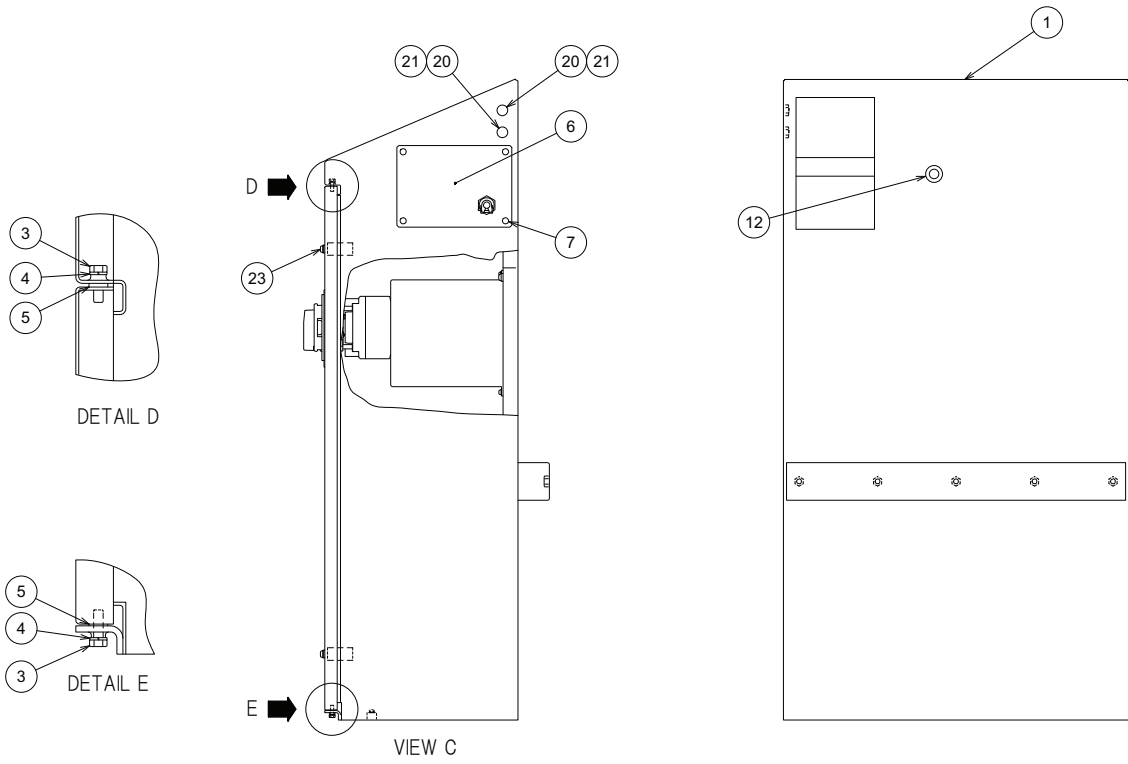

RB01539--C

Unit No. 78
Electric AS(2)

| Index | Code | Parts Name | Drawing No. | Type | Maker | Q'ty | Note |
|-------|----------|---------------------|-------------|------------------------------|-------|------|------|
| 1 | 10300821 | Control Box | RB00774--C | | | 1 | |
| 2 | 10300822 | Control Box Cover | RB00775--B | | | 1 | |
| 3 | 10325830 | Bolt | P330010005 | M5X16 | JIS | 2 | |
| 4 | 10322215 | Spring Washer | P336050004 | 5 | JIS | 2 | |
| 5 | 10323127 | Washer | P336000059 | 5(Polished Round) | JIS | 2 | |
| 6 | 10300824 | Cover | RB00776--B | | | 1 | |
| 7 | 10322224 | Pan Head Screw | P334100039 | M5X10 | JIS | 4 | |
| 8 | 10301989 | Panel Arrangement | RB01581--C | | | 1 | |
| 9 | 10325313 | Pan Head Screw | P334100058 | M6X16 | JIS | 6 | |
| 10 | 10301669 | Control Panel | RB00795--B | | | 1 | |
| 11 | 10372307 | Truss Head Screw | P334130009 | M5X12 | JIS | 6 | |
| 12 | 10301115 | Bush for Cable | RB0160001- | D22 | | 3 | |
| 13 | 10300830 | Cable Retainer A | RB00779--B | | | 1 | |
| 14 | 10300831 | Cable Retainer B | RB00780--B | | | 1 | |
| 15 | 10380944 | Sems Pan Head Screw | P334200063 | M6X16(Spring/Polished Round) | JIS | 4 | |
| 16 | 10301119 | CAPCON | RB0160006- | D34 | | 1 | |
| 17 | 10301069 | Charging Mark D | RB01517--- | 125MM | | 1 | |
| 18 | 10301068 | Sticker (Ground) | RB01516--- | | | 1 | |
| 19 | 10301120 | Grommet | RB0160007- | D18 | | 1 | |

Unit No. 78
Electric AS(2)

| Index | Code | Parts Name | Drawing No. | Type | Maker | Q'ty | Note |
|-------|----------|----------------------|-------------|------------------------------|-------|------|------|
| 20 | 10321923 | Washer | P336000006 | 8(Normal) | JIS | 2 | |
| 21 | 10342325 | Hex Socket Cap Screw | P330230004 | M8X15 | | 2 | |
| 22 | 10301121 | Grommet | RB0160008- | W4XL250 | | 1 | |
| 23 | 10322133 | Truss Head Screw | P334130014 | M6X20 | JIS | 2 | |
| 24 | 10589252 | Sems Pan Head Screw | P334200013 | M4X10(Spring/Polished Round) | JIS | 2 | |

Unit No. 79
 Electric AS(3)-1/2 <Panel Arrangement>

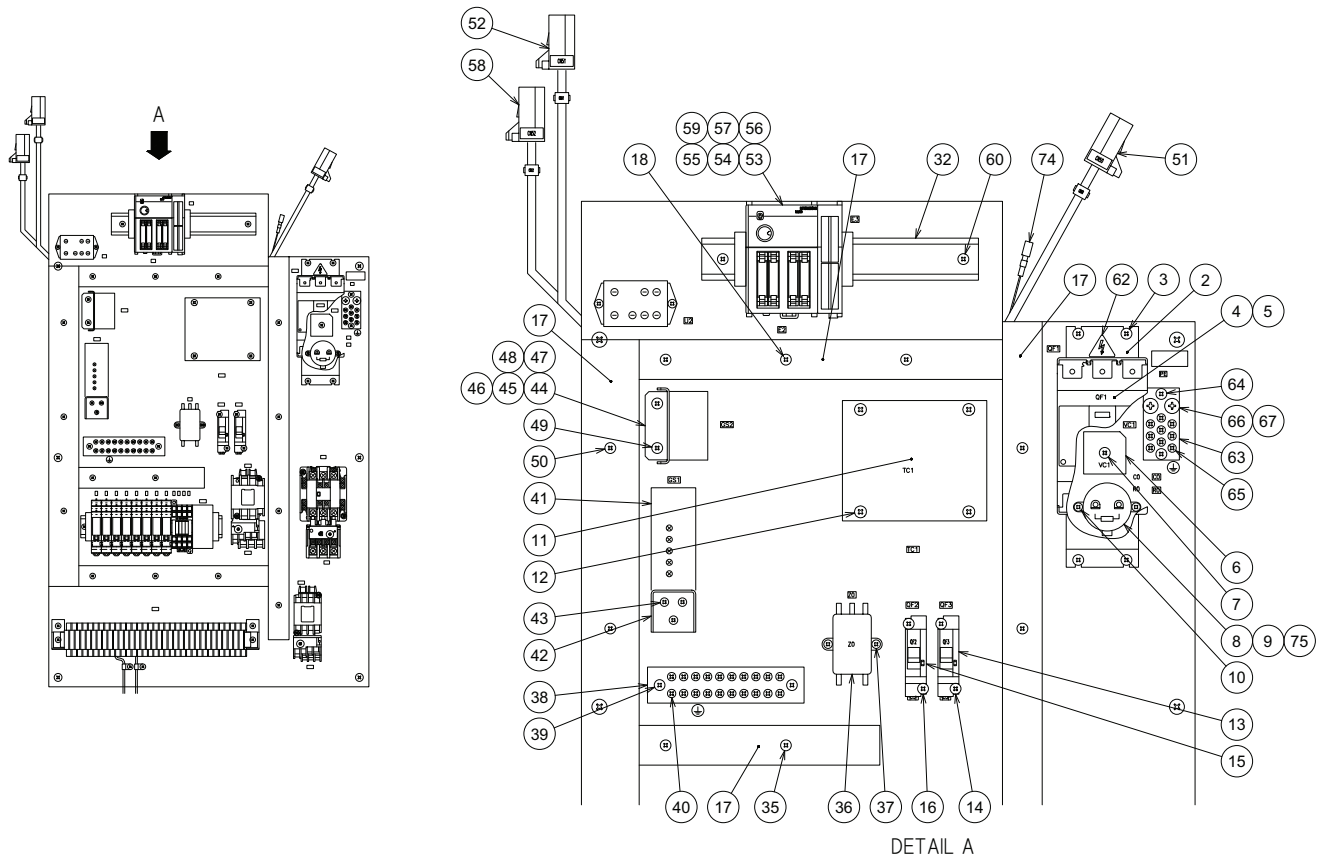

RB01581--C

Unit No. 79
 Electric AS(3)-2/2 <Panel Arrangement>

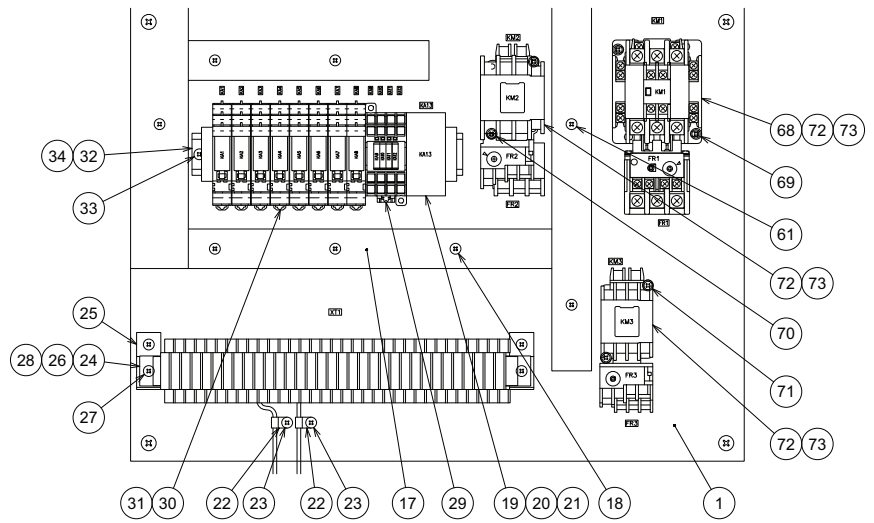
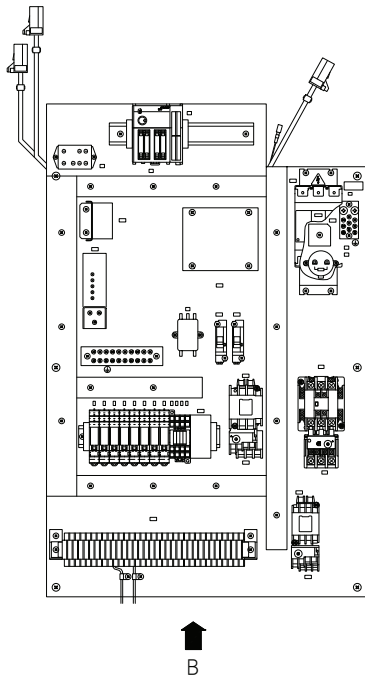

DETAIL B

RB01581--C

Unit No. 79
Electric AS(3)

| Index | Code | Parts Name | Drawing No. | Type | Maker | Q'ty | Note |
|-------|----------|---------------------------------|-------------|------------------------------|---------------|------|------|
| 1 | 10301673 | Control Panel | RB00796--C | | | 1 | |
| 2 | 10300833 | Breaker Bracket | RB00782--C | | | 1 | |
| 3 | 10589252 | Sems Pan Head Screw | P334200013 | M4X10(Spring/Polished Round) | JIS | 4 | |
| 4 | 10300195 | Accessory (Low Voltage Breaker) | P812098065 | TCL-05SV3 | MITSUBISHI | 1 | |
| 5 | 10300194 | Accessory (Low Voltage Breaker) | P812098064 | F-05SV | MITSUBISHI | 1 | |
| 6 | 10300207 | Rectifier | P840068014 | KBPC35-10 | SUMGLE | 1 | VC1 |
| 7 | 10589252 | Sems Pan Head Screw | P334200013 | M4X10(Spring/Polished Round) | JIS | 1 | |
| 8 | 10300211 | Aluminum Capacitor | P840108041 | 50V10000Micro Farad | HWAKAI | 1 | C0 |
| 9 | 10300212 | Resistor | P841128056 | RS2W(5.1 kOhm) | YCX | 1 | R0 |
| 10 | 10589250 | Sems Pan Head Screw | P334200010 | M3X10(Spring/Polished Round) | JIS | 2 | |
| 11 | 10300180 | Transformer | P772008054 | JBK5-400 | JUCHE | 1 | TC1 |
| 12 | 10380975 | Sems Pan Head Screw | P334200047 | M5X12(Spring/Polished Round) | JIS | 4 | |
| 13 | 10300196 | Low Voltage Breaker | P812128227 | CP31FS/2D | FUJI Electric | 1 | QF3 |
| 14 | 10380968 | Sems Pan Head Screw | P334200011 | M4X12(Spring/Polished Round) | JIS | 2 | |
| 15 | 10300197 | Low Voltage Breaker | P812128280 | CP31FS/15D | FUJI Electric | 1 | QF2 |
| 16 | 10589252 | Sems Pan Head Screw | P334200013 | M4X10(Spring/Polished Round) | JIS | 2 | |
| 17 | 10301676 | Duct | RB00799--A | | | 1 | |
| 18 | 10589252 | Sems Pan Head Screw | P334200013 | M4X10(Spring/Polished Round) | JIS | 6 | |
| 19 | 10301576 | Control Relay | P800002015 | MY2N-D2-DC24V | OMRON | 1 | KA13 |

Unit No. 79
Electric AS(3)

| Index | Code | Parts Name | Drawing No. | Type | Maker | Q'ty | Note |
|-------|----------|---------------------------------|-------------|------------------------------|-------------------|------|--------|
| 20 | 10300215 | Accessory for Connector | P862188020 | PYF08A | OMRON | 1 | |
| 21 | 10349515 | Accessory for Connector | P862188011 | PYC-A1 | OMRON | 1 | |
| 22 | 10579245 | Cable Clamp | P381048008 | EMT-2N | TAKEUCHI Industry | 2 | |
| 23 | 10589252 | Sems Pan Head Screw | P334200013 | M4X10(Spring/Polished Round) | JIS | 2 | |
| 24 | 10301675 | Terminal Block ASSY | RB00798--B | | | 1 | XT1 |
| 25 | 10301117 | Tilting Attachment | RB0160003- | (Conform to) BP23-2S | | 2 | |
| 26 | 10301661 | Written Order (Fixing Resistor) | RB0079407A | | | 1 | |
| 27 | 10589252 | Sems Pan Head Screw | P334200013 | M4X10(Spring/Polished Round) | JIS | 6 | |
| 28 | 10301579 | Resistor | P841128057 | RS5W(470 Ohm) | YCX | 2 | |
| 29 | 10421120 | Control Relay | P800004060 | RS4N-DE | FUJI Electric | 1 | KA9-12 |
| 30 | 10589483 | Control Relay | P800002075 | G2R-1-SND-DC24V | OMRON | 8 | KA1-8 |
| 31 | 10589484 | Accessory for Control Relay | P800082015 | P2RF-05-E | OMRON | 8 | |
| 32 | 10301679 | DIN Rail | RB00803--A | | | 1 | |
| 33 | 10589252 | Sems Pan Head Screw | P334200013 | M4X10(Spring/Polished Round) | JIS | 2 | |
| 34 | 10337281 | Terminal Parts | P864052008 | BNL6 | IDEC | 4 | |
| 35 | 10589252 | Sems Pan Head Screw | P334200013 | M4X10(Spring/Polished Round) | JIS | 2 | |
| 36 | 10337328 | Noise Filter | P840048003 | ZCB2203-11 | TDK | 1 | Z0 |
| 37 | 10589250 | Sems Pan Head Screw | P334200010 | M3X10(Spring/Polished Round) | JIS | 2 | |
| 38 | 10300834 | Ground Bar | RB00783--A | | | 1 | |

Unit No. 79
Electric AS(3)

| Index | Code | Parts Name | Drawing No. | Type | Maker | Q'ty | Note |
|-------|----------|---------------------------------|-------------|------------------------------|---------------|------|------|
| 39 | 10380683 | Sems Pan Head Screw | P334200034 | M4X16(Spring/Polished Round) | JIS | 2 | |
| 40 | 10380682 | Sems Pan Head Screw | P334200032 | M4X6(Spring/Polished Round) | JIS | 20 | |
| 41 | 10579233 | Switching Power Supply | P772124027 | JWS50-24/A | DENSEI-LAMBDA | 1 | GS1 |
| 42 | 10579234 | Accessory for Power Supply | P772188003 | L-09 | DENSEI-LAMBDA | 1 | |
| 43 | 10589249 | Sems Pan Head Screw | P334200008 | M3X6(Spring/Polished Round) | JIS | 6 | |
| 44 | 10579235 | Switching Power Supply | P772123024 | LDA10F-12-SN | COSEL | 1 | GS2 |
| 45 | 10589249 | Sems Pan Head Screw | P334200008 | M3X6(Spring/Polished Round) | JIS | 2 | |
| 46 | 10301674 | LDA Power Supply Bracket | RB00797--B | | | 1 | |
| 47 | 10301662 | GS2 Primary Cable | RB0079408A | | | 1 | |
| 48 | 10301663 | GS2 Secondary Cable | RB0079409A | | | 1 | |
| 49 | 10589252 | Sems Pan Head Screw | P334200013 | M4X10(Spring/Polished Round) | JIS | 2 | |
| 50 | 10589252 | Sems Pan Head Screw | P334200013 | M4X10(Spring/Polished Round) | JIS | 3 | |
| 51 | 10301659 | Cable CN50F | RB0079405B | | | 1 | CN50 |
| 52 | 10301660 | Cable CN51F | RB0079406A | | | 1 | CN51 |
| 53 | 10301575 | Programmable Controller | P767406010 | FX3UC-64MT/DSS | MITSUBISHI | 1 | E2 |
| 54 | 10582061 | Accessory (Program Controller) | P767486029 | FX3U-FLROM-64 | MITSUBISHI | 1 | |
| 55 | 10579239 | Accessory (Indicator Apparatus) | P767588010 | D4RVM10 | Diatrend | 1 | |
| 56 | 10301655 | Cable CN1 | RB0079401C | | | 1 | |
| 57 | 10301656 | Cable CN2 | RB0079402A | | | 1 | |

Unit No. 79
Electric AS(3)

| Index | Code | Parts Name | Drawing No. | Type | Maker | Q'ty | Note |
|-------|----------|---------------------------|-------------|------------------------------|---------------|------|---------------------------------|
| 58 | 10301657 | Cable CN3 | RB0079403A | | | 1 | CN52 |
| 59 | 10301658 | Cable CN4 | RB0079404B | | | 1 | |
| 60 | 10589252 | Sems Pan Head Screw | P334200013 | M4X10(Spring/Polished Round) | JIS | 2 | |
| 61 | 10589252 | Sems Pan Head Screw | P334200013 | M4X10(Spring/Polished Round) | JIS | 4 | |
| 62 | 10301123 | Charging Mark | RB0160010- | 20MM | | 1 | |
| 63 | 10300835 | Ground Bar | RB00784--A | | | 1 | PE |
| 64 | 10380683 | Sems Pan Head Screw | P334200034 | M4X16(Spring/Polished Round) | JIS | 2 | |
| 65 | 10380682 | Sems Pan Head Screw | P334200032 | M4X6(Spring/Polished Round) | JIS | 9 | |
| 66 | 10300140 | Sems Pan Head Screw | P334200084 | M6X8(Spring/Polished Round) | JIS | 2 | |
| 67 | 10300143 | Washer | P336000074 | 6(Polished Round)T=1.0 | JIS | 2 | |
| 68 | 10589493 | Accessory (Magnet Switch) | P810184001 | SZ-A20 | FUJI Electric | 1 | KM1,FR1 |
| 69 | 10380683 | Sems Pan Head Screw | P334200034 | M4X16(Spring/Polished Round) | JIS | 2 | |
| 70 | 10380683 | Sems Pan Head Screw | P334200034 | M4X16(Spring/Polished Round) | JIS | 2 | |
| 71 | 10380683 | Sems Pan Head Screw | P334200034 | M4X16(Spring/Polished Round) | JIS | 2 | |
| 72 | 10301116 | Spark Killer | RB0160002- | (Conform to) SKVB104120 | | 3 | |
| 73 | 10300210 | Varistor | P840078056 | TUR20D112K | JOCOL | 9 | |
| 74 | 10300214 | Plug Type Terminal | P862148060 | PC-2005F | NICHIFU | 1 | N24A |
| 75 | 10301580 | Insulating Sleeve | P869238018 | OA-BCP5 | OHM Electric | 2 | |
| 76 | 10301079 | Name Plate | RB0154804A | | | 1 | List Only/US(AC230V)/AS(AC460V) |

Unit No. 80
 Electric AS(4) <Control Panel>

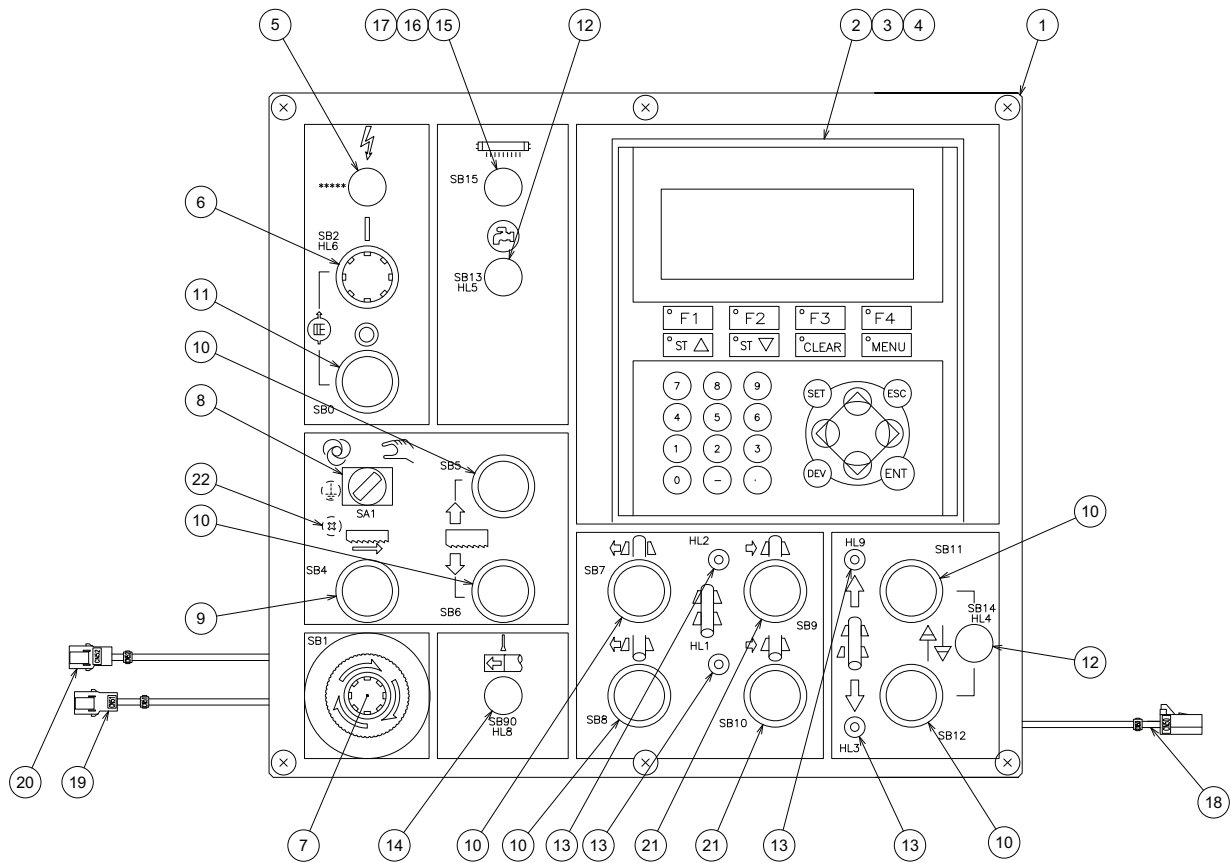

RB00795--B

Unit No. 80
Electric AS(4)

| Index | Code | Parts Name | Drawing No. | Type | Maker | Q'ty | Note |
|-------|----------|---------------------------------|-------------|-------------------------|-----------------|------|-----------------|
| 1 | 10301677 | Name Plate | RB00800-B | | | 1 | |
| 2 | 10579261 | Indicator Apparatus | P767508019 | F930GOT-BBD-K | MITSUBISHI | 1 | |
| 3 | 10301678 | F Switch Sheet | RB00801--- | | | 1 | |
| 4 | 10579264 | Accessory (Indicator Apparatus) | P767588011 | F9GT-30PSC | MITSUBISHI | 2 | |
| 5 | 10300213 | Indicator Apparatus | P843024023 | AH165-ZWH3 | FUJI Electric | 1 | HL7 |
| 6 | 10579339 | Push Button Switch (with Lamp) | P822084031 | AR22F0L-10H3W | FUJI Electric | 1 | SB2,HL6 |
| 7 | 10300199 | Push Button Switch | P821084115 | AR22V0R-01R | FUJI Electric | 1 | SB1 |
| 8 | 10337159 | Key Select Switch | P820004027 | AH165-P2B11 | FUJI Electric | 1 | SA1 |
| 9 | 10579341 | Push Button Switch | P821084154 | AR22G2R-20W | FUJI Electric | 1 | SB4 |
| 10 | 10589510 | Push Button Switch | P821084080 | AR22F0R-10W | FUJI Electric | 6 | SB5,6,7,8,11,12 |
| 11 | 10300198 | Push Button Switch | P821084081 | AR22F0R-01B | FUJI Electric | 1 | SB0 |
| 12 | 10300204 | Push Button Switch (with Lamp) | P822064076 | AH165-L5W11E3 | FUJI Electric | 2 | SB13,14,HL4,5 |
| 13 | 10583452 | Indicator Apparatus | P843188016 | DB24-89WUS | MARUYASU DENGYO | 4 | HL1,2,3,9 |
| 14 | 10578823 | Blind Plug | P229138005 | AHX622-B | FUJI Electric | 1 | SB90,HL8 |
| 15 | 10337521 | Push Button Switch | P821064009 | AH165-E5W22 | FUJI Electric | 1 | SB15 |
| 16 | 10300208 | Varistor | P840078053 | TUR20D271K | JOCOL | 1 | |
| 17 | 10301116 | Spark Killer | RB0160002- | (Conform to) SKVB104120 | | 1 | |
| 18 | 10301670 | Cable (50m) | RB0079501A | | | 1 | CN50 |
| 19 | 10301671 | Cable (51m) | RB0079502A | | | 1 | CN51 |

Unit No. 80
Electric AS(4)

| Index | Code | Parts Name | Drawing No. | Type | Maker | Q'ty | Note |
|-------|----------|---------------------|-------------|------------------------------|---------------|------|--------|
| 20 | 10301672 | Cable (52m) | RB0079503A | | | 1 | CN52 |
| 21 | 10300200 | Push Button Switch | P821084195 | AR22G2R-10W | FUJI Electric | 2 | SB9,10 |
| 22 | 10589252 | Sems Pan Head Screw | P334200013 | M4X10(Spring/Polished Round) | JIS | 1 | |

Unit No. 81
 Electric AS(5)-1/2 <AS Specification Component>

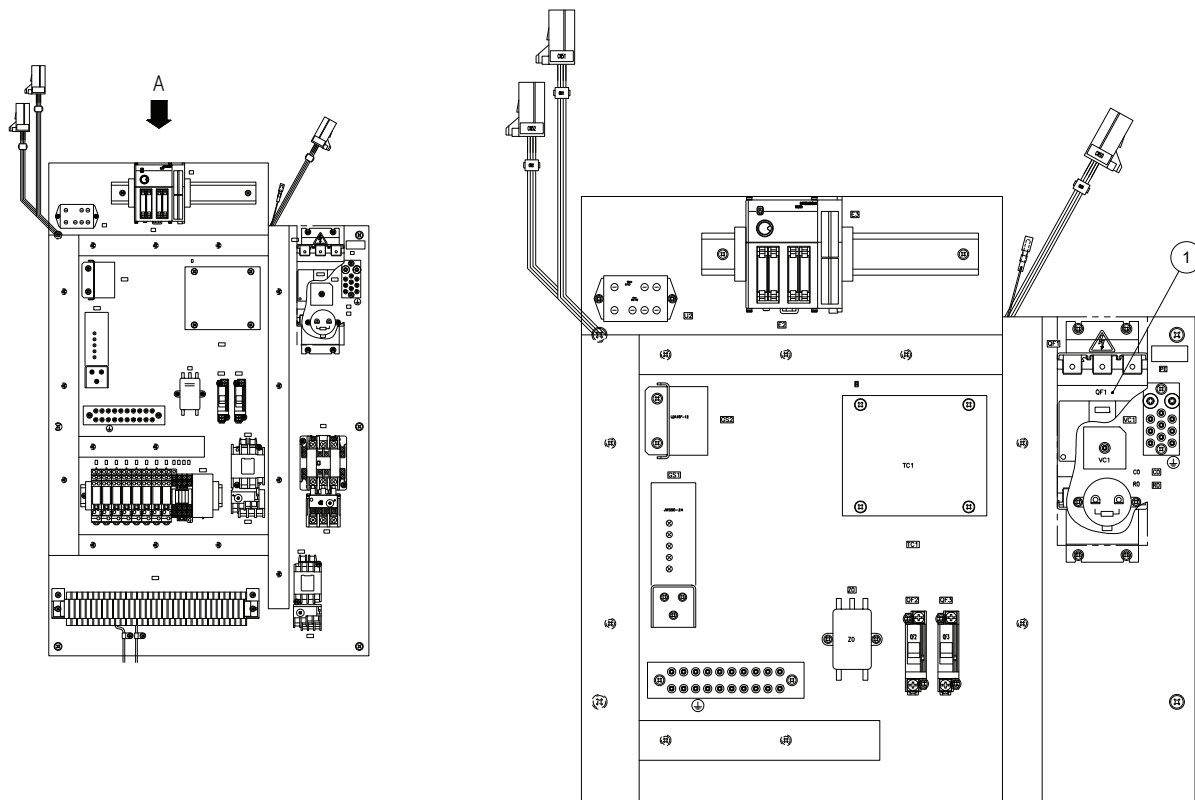

DETAIL A

RB01575---
 (RB01581--C)

Unit No. 81
 Electric AS(5)-2/2 <AS Specification Component>

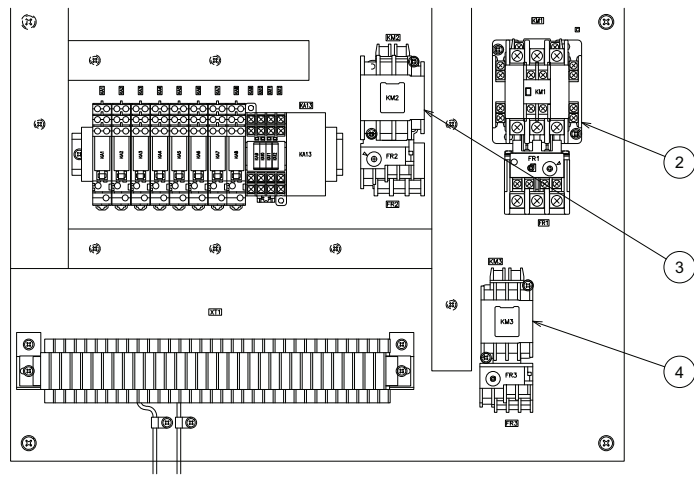
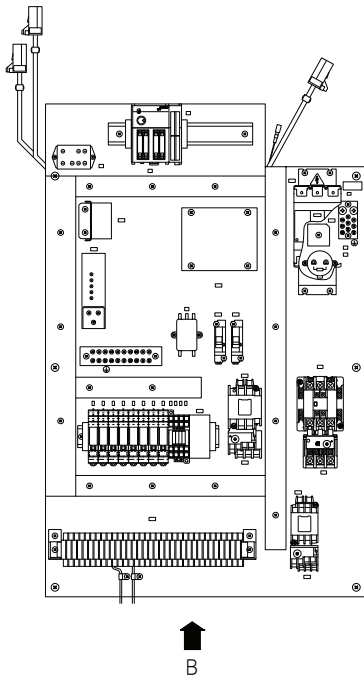

DETAIL B

RB01575---
 (RB01581--C)

Unit No. 81
Electric AS(5)

| Index | Code | Parts Name | Drawing No. | Type | Maker | Q'ty | Note |
|-------|----------|---------------------|-------------|-------------------------|---------------|------|---------|
| 1 | 10300187 | Low Voltage Breaker | P812008026 | NF32-SV-3P-30A | MITSUBISHI | 1 | QF1 |
| 2 | 10579413 | Magnet Switch | P810044147 | SW-N1/3H(9A)AC100V | FUJI Electric | 1 | KM1,FR1 |
| 3 | 10579402 | Magnet Switch | P810044142 | SW-05/3H(2.8A)AC100V-2A | FUJI Electric | 1 | KM2,FR2 |
| 4 | 10579405 | Magnet Switch | P810044137 | SW-0/3H(0.36A)AC100V | FUJI Electric | 1 | KM3,FR3 |

Unit No. 82
Standard Accessory(1) <DOM>

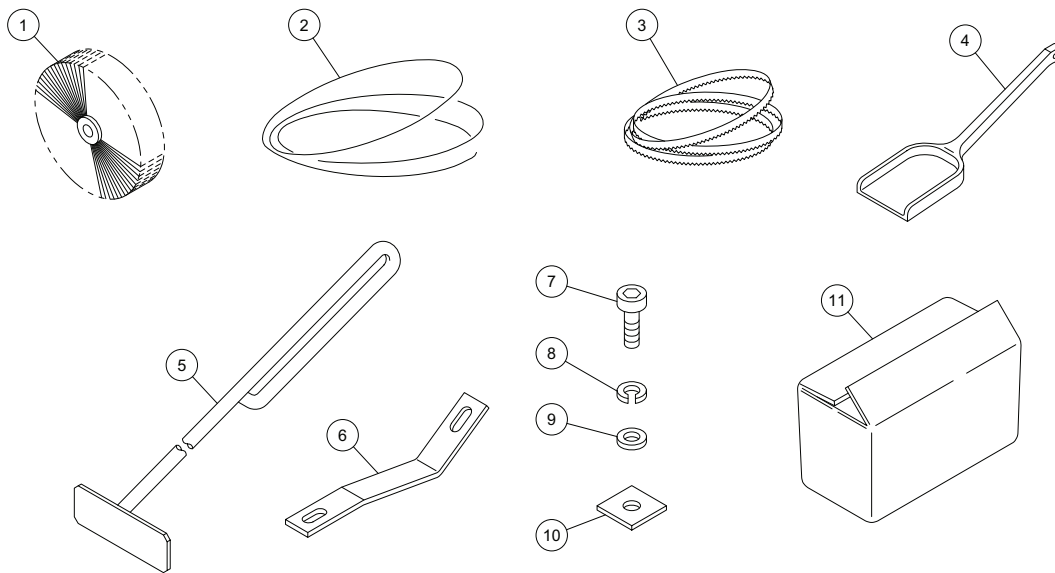

Unit No. 82

Standard Accessory(1)

| Index | Code | Parts Name | Drawing No. | Type | Maker | Q'ty | Note |
|-------|----------|--------------------------|-------------|-----------------------|-------|------|------|
| 1 | 10300687 | Wire Brush | RB00609--- | | | 2 | |
| 2 | 10311214 | Polyurethane Rope | 0636547 C | D4X1730L | | 3 | |
| 3 | 10301303 | Band Saw Blade | P632204057 | SGLB-34-1.1-4570-3/4P | AMADA | 1 | |
| 4 | 10321201 | Chip Shovel | 0602631 | | | 1 | |
| 5 | 10365520 | Chip Remover | 0605565 | | | 1 | |
| 6 | 10345214 | Shipping Bracket | 1230806 A | | | 1 | |
| 7 | 10341713 | Hex Socket Cap Screw | P330240006 | M10X20 | | 2 | |
| 8 | 10001520 | Spring Washer | P336050007 | 10 | JIS | 2 | |
| 9 | 10325021 | Washer | P336000007 | 10(Normal) | JIS | 4 | |
| 10 | 10345217 | Fiber | 1230807 | | | 2 | |
| 11 | 10383300 | Corrugated Cardboard Box | P370600003 | 305X210X615 | | 1 | |

Unit No. 83
Standard Accessory(2) <US,EU,AS>

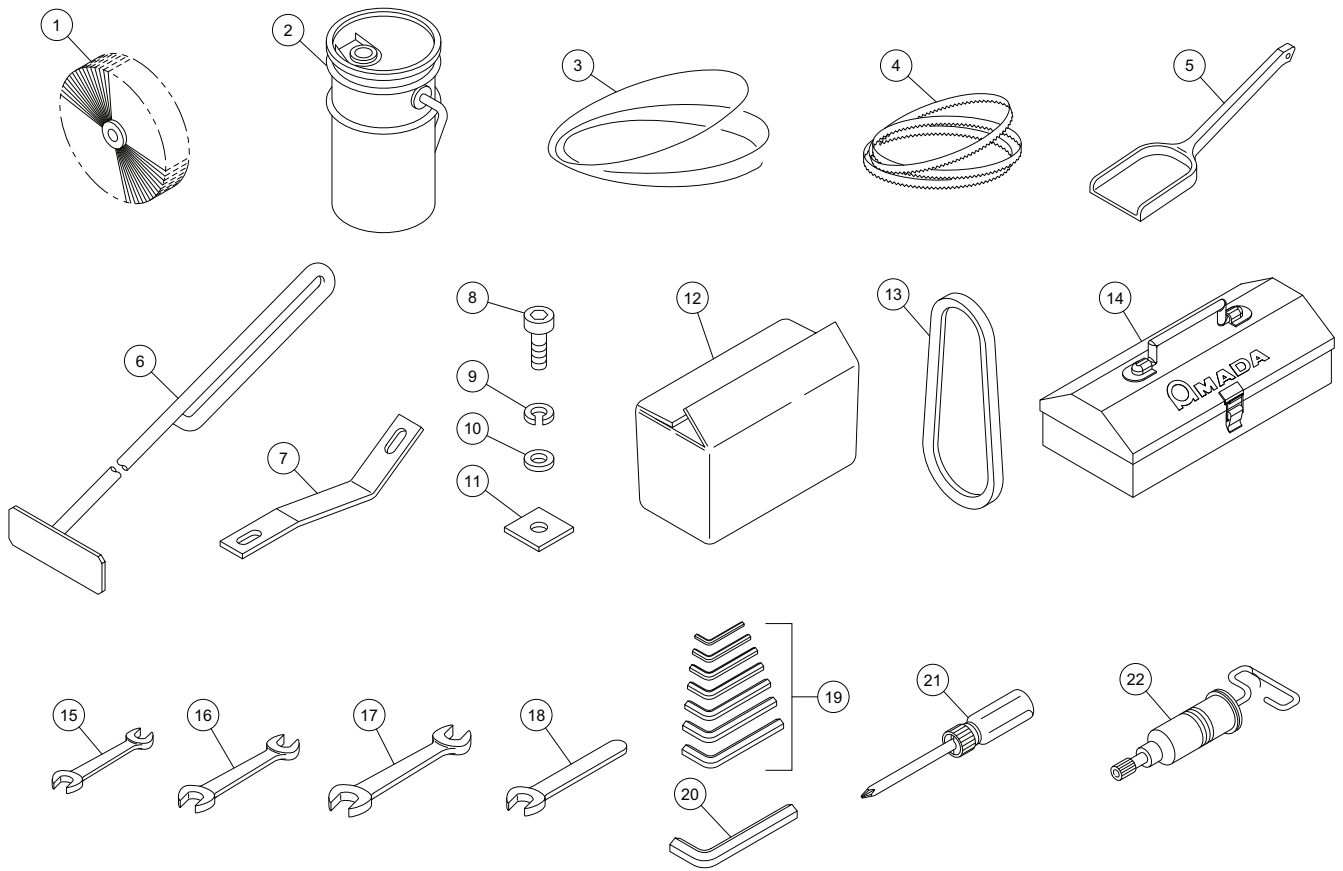

1278893--A

Unit No. 83

Standard Accessory(2)

| Index | Code | Parts Name | Drawing No. | Type | Maker | Q'ty | Note |
|-------|----------|--------------------------|-------------|-----------------------|-------|------|------|
| 1 | 10300687 | Wire Brush | RB00609--- | | | 3 | |
| 2 | 10419380 | Hydraulic Oil | P238000010 | ISO-VG32-40L | AMADA | 1 | |
| 3 | 10311214 | Polyurethane Rope | 0636547 C | D4X1730L | | 3 | |
| 4 | 10301303 | Band Saw Blade | P632204057 | SGLB-34-1.1-4570-3/4P | AMADA | 1 | |
| 5 | 10321201 | Chip Shovel | 0602631 | | | 1 | |
| 6 | 10365520 | Chip Remover | 0605565 | | | 1 | |
| 7 | 10345214 | Shipping Bracket | 1230806 A | | | 1 | |
| 8 | 10341713 | Hex Socket Cap Screw | P330240006 | M10X20 | | 2 | |
| 9 | 10001520 | Spring Washer | P336050007 | 10 | JIS | 2 | |
| 10 | 10325021 | Washer | P336000007 | 10(Normal) | JIS | 4 | |
| 11 | 10345217 | Fiber | 1230807 | | | 2 | |
| 12 | 10383300 | Corrugated Cardboard Box | P370600003 | 305X210X615 | | 1 | |
| 13 | 10380583 | V-belt | P223000016 | M48 | | 1 | |
| 14 | 10581225 | Tool Box | 7912021 | 350X150X65(TM-2) | | 1 | |
| 15 | 10345208 | Wrench | P351010013 | 13X17 | | 1 | |
| 16 | 10345209 | Wrench | P351010010 | 19X22 | | 1 | |
| 17 | 10345210 | Wrench | P351010003 | 24X27 | | 1 | |
| 18 | 10345211 | Single Ended Wrench | P351000022 | 14 | | 1 | |
| 19 | 10301287 | Bar Wrench Set | P351040002 | 2.5-3-4-5-6-8-10 | | 1 | |

Unit No. 83

Standard Accessory(2)

| Index | Code | Parts Name | Drawing No. | Type | Maker | Q'ty | Note |
|-------|----------|------------------|-------------|------------|--------|------|------|
| 20 | 10485309 | Socket Screw Key | P351030011 | 14 | JIS | 1 | |
| 21 | 10485310 | Screwdriver | P353000004 | H2(Normal) | JIS | 1 | |
| 22 | 10345225 | Grease Gun | P359308003 | KH-35 | YAMADA | 1 | |

Unit No. 84
Standard Accessory(3) <CHI>

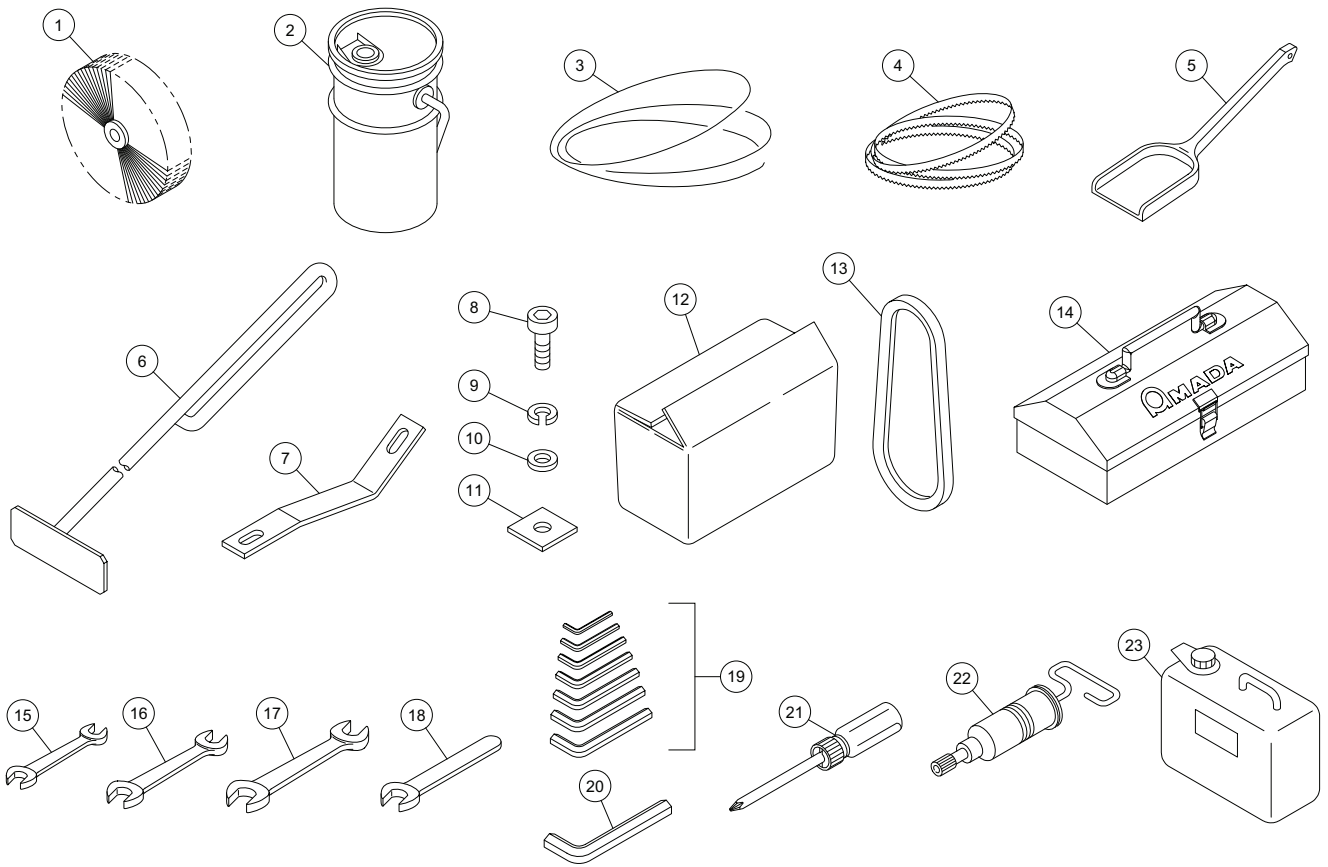

1278894---

Unit No. 84

Standard Accessory(3)

| Index | Code | Parts Name | Drawing No. | Type | Maker | Q'ty | Note |
|-------|----------|--------------------------|-------------|-----------------------|-------|------|------|
| 1 | 10300687 | Wire Brush | RB00609--- | | | 3 | |
| 2 | 10419380 | Hydraulic Oil | P238000010 | ISO-VG32-40L | AMADA | 1 | |
| 3 | 10311214 | Polyurethane Rope | 0636547 C | D4X1730L | | 3 | |
| 4 | 10301303 | Band Saw Blade | P632204057 | SGLB-34-1.1-4570-3/4P | AMADA | 1 | |
| 5 | 10321201 | Chip Shovel | 0602631 | | | 1 | |
| 6 | 10365520 | Chip Remover | 0605565 | | | 1 | |
| 7 | 10345214 | Shipping Bracket | 1230806 A | | | 1 | |
| 8 | 10341713 | Hex Socket Cap Screw | P330240006 | M10X20 | | 2 | |
| 9 | 10001520 | Spring Washer | P336050007 | 10 | JIS | 2 | |
| 10 | 10325021 | Washer | P336000007 | 10(Normal) | JIS | 4 | |
| 11 | 10345217 | Fiber | 1230807 | | | 2 | |
| 12 | 10383300 | Corrugated Cardboard Box | P370600003 | 305X210X615 | | 1 | |
| 13 | 10380583 | V-belt | P223000016 | M48 | | 1 | |
| 14 | 10581225 | Tool Box | 7912021 | 350X150X65(TM-2) | | 1 | |
| 15 | 10345208 | Wrench | P351010013 | 13X17 | | 1 | |
| 16 | 10345209 | Wrench | P351010010 | 19X22 | | 1 | |
| 17 | 10345210 | Wrench | P351010003 | 24X27 | | 1 | |
| 18 | 10345211 | Single Ended Wrench | P351000022 | 14 | | 1 | |
| 19 | 10301287 | Bar Wrench Set | P351040002 | 2.5-3-4-5-6-8-10 | | 1 | |

Unit No. 84

Standard Accessory(3)

| Index | Code | Parts Name | Drawing No. | Type | Maker | Q'ty | Note |
|-------|----------|------------------|-------------|------------|--------|------|------|
| 20 | 10485309 | Socket Screw Key | P351030011 | 14 | JIS | 1 | |
| 21 | 10485310 | Screwdriver | P353000004 | H2(Normal) | JIS | 1 | |
| 22 | 10345225 | Grease Gun | P359308003 | KH-35 | YAMADA | 1 | |
| 23 | 10301323 | Cutting Fluid | RB0054039- | 3L | | 2 | |

Unit No. 85
Standard Accessory(4) <HFA400W>

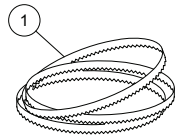

P632204013

Unit No. 85

Standard Accessory(4)

| Index | Code | Parts Name | Drawing No. | Type | Maker | Q'ty | Note |
|-------|----------|----------------|-------------|--------------------|-------|------|------|
| 1 | 10583730 | Band Saw Blade | P632204013 | SGLB41X1.3X4570X34 | AMADA | 1 | |

Unit No. 86
Saw Blade Breakage Detection LS

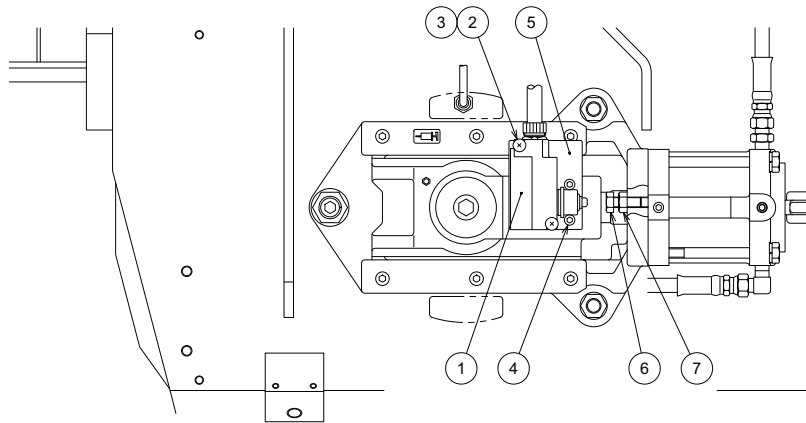
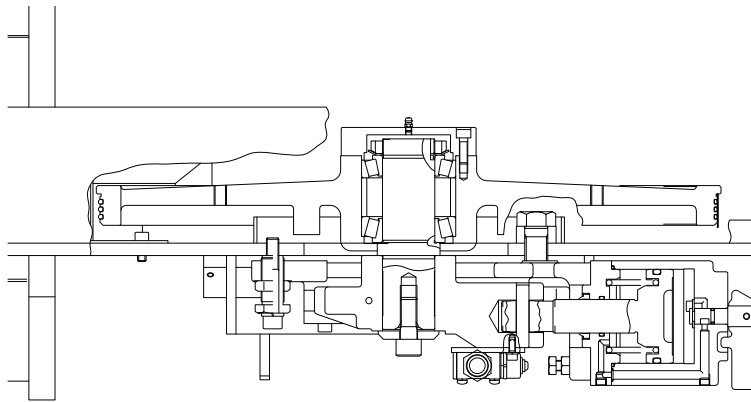

1278880---
(1278780--B)

Unit No. 86

Saw Blade Breakage Detection LS

| Index | Code | Parts Name | Drawing No. | Type | Maker | Q'ty | Note |
|-------|----------|----------------------|-------------|--------------------|-------|------|------|
| 1 | 10318541 | Limit Switch | P828012030 | ZV2-N-2 | OMRON | 1 | |
| 2 | 10377210 | Pan Head Screw | P334100046 | M5X30 | JIS | 2 | |
| 3 | 10322215 | Spring Washer | P336050004 | 5 | JIS | 2 | |
| 4 | 10343434 | Hex Socket Cap Screw | P330220005 | M6X14 | MOURI | 2 | |
| 5 | 10419512 | LS Setting Plate | 1109075 B | | | 1 | |
| 6 | 10325724 | Bolt | P330040033 | M10X30(All-thread) | MOURI | 1 | |
| 7 | 10427991 | Nut | P332000006 | M10 | JIS | 1 | |

Unit No. 87
Multi-vise-1/2

1 Index 2-35

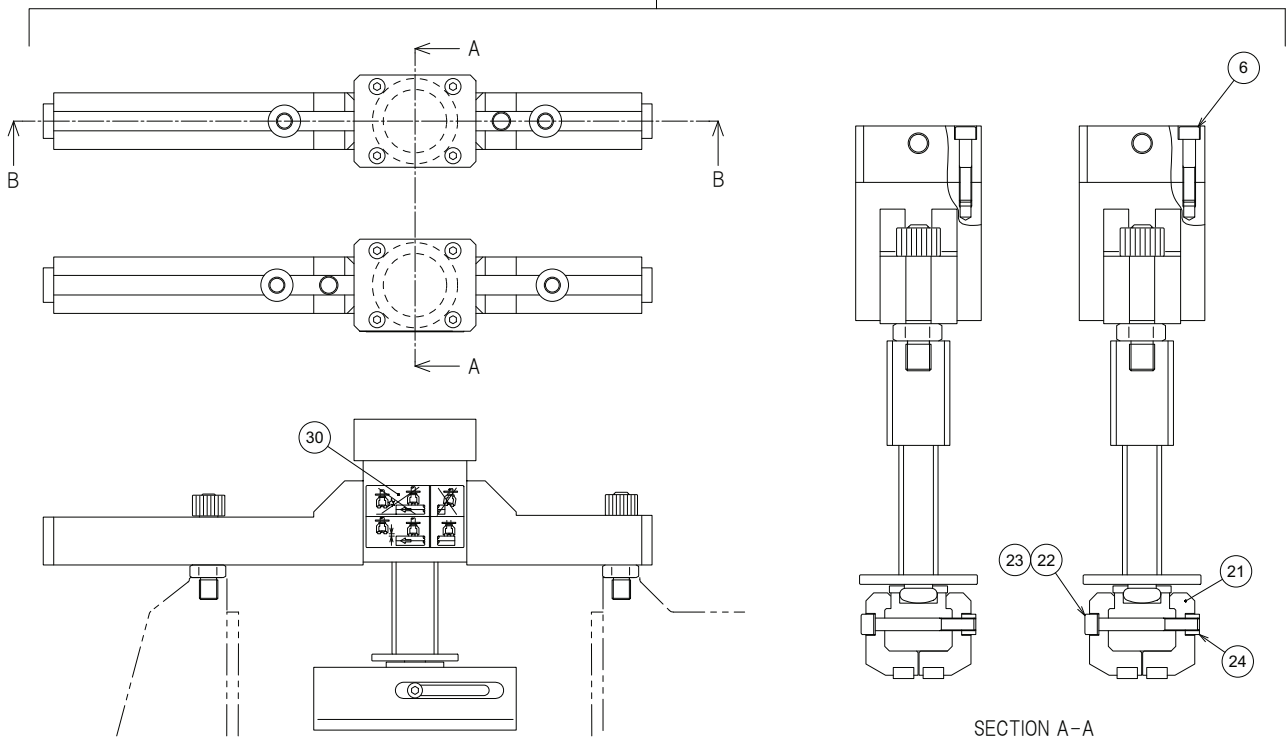

Unit No. 87
Multi-vise-2/2

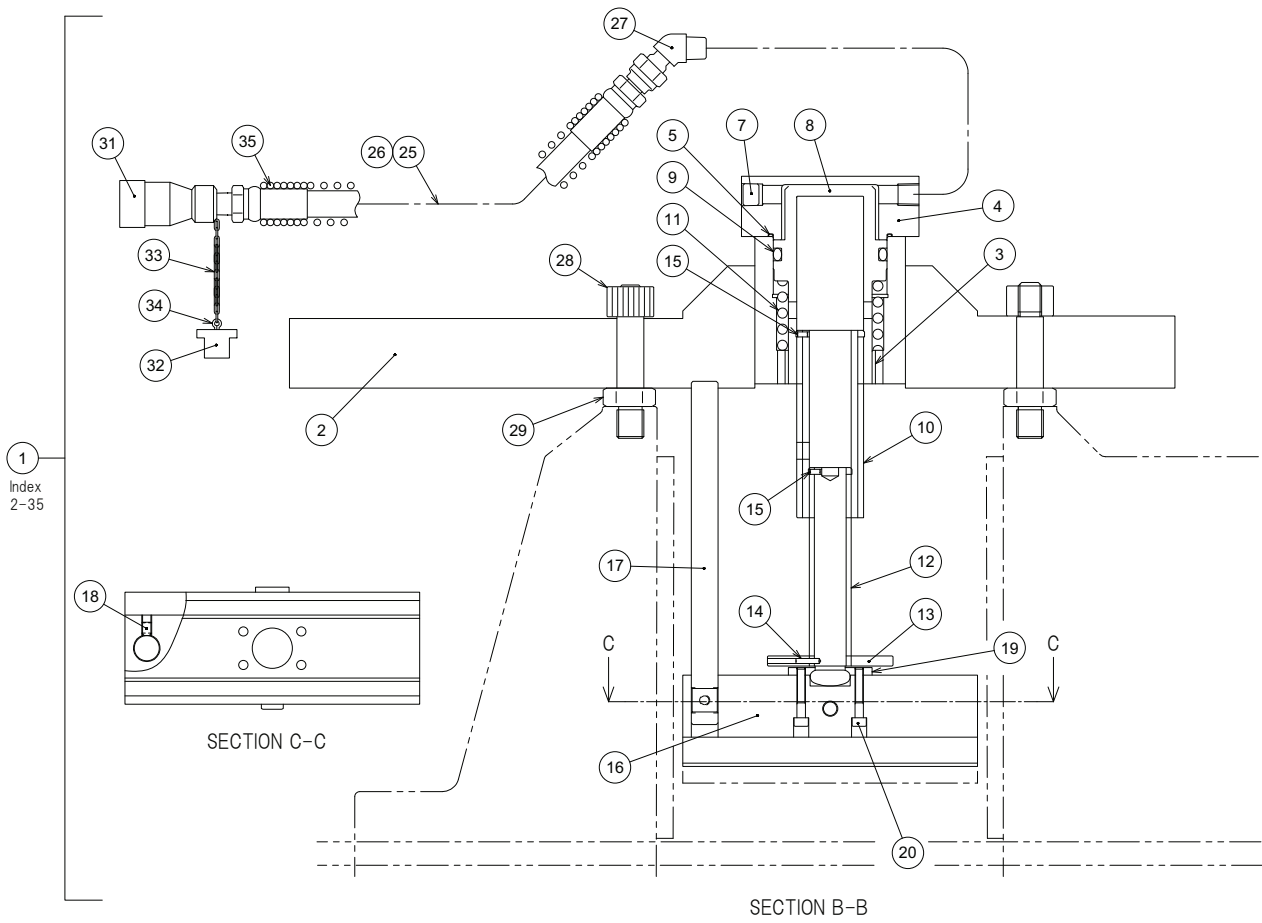

1278813--A

Unit No. 87

Multi-vise

| Index | Code | Parts Name | Drawing No. | Type | Maker | Q'ty | Note |
|-------|----------|----------------------|-------------|------------------------------------|-------------|------|-----------------|
| 1 | 10302105 | Multi-vise ASSY | SBS0137--- | 1238615 B, 1238617, 1280777 others | | 1 | with Index 2-35 |
| 2 | 10419389 | Cylinder Body | 1238615 B | | | 2 | |
| 3 | 10581239 | Plain Bearing | P407003193 | DUB5020 | DAIDO METAL | 2 | |
| 4 | 10378616 | Cylinder Cap | 1238616 | | | 2 | |
| 5 | 10339017 | O Ring | P590032047 | S71 | NOK | 2 | |
| 6 | 10323207 | Hex Socket Cap Screw | P330230010 | M8X40 | | 8 | |
| 7 | 10300171 | Plug for Piping | P580208021 | PT-1/4 | | 2 | |
| 8 | 10378617 | Piston | 1238617 | | | 2 | |
| 9 | 10380808 | O Ring | P590002055 | 1A-P58 | NOK | 2 | |
| 10 | 10378618 | Tension Rod | 1238618 | | | 2 | |
| 11 | 10339049 | Spring | 1280781 A | | | 2 | |
| 12 | 10000635 | Clamper Screw | 1238619 | | | 2 | |
| 13 | 10000713 | Handle | 1280777 | | | 2 | |
| 14 | 10331237 | Spring Pin | P337030013 | 3X14AW | JIS | 2 | |
| 15 | 10339125 | Spring Pin | P337030009 | 3X6AW | JIS | 4 | |
| 16 | 10000733 | Clamper | 1230877 | | | 2 | |
| 17 | 10378620 | Guide Bar | 1238620 | | | 2 | |
| 18 | 10322120 | Socket Set Screw | P330590018 | M6X8(Dimple Type) | JIS | 2 | |
| 19 | 10000925 | Clamping Plate | 1230878 | | | 4 | |

Unit No. 87

Multi-vise

| Index | Code | Parts Name | Drawing No. | Type | Maker | Q'ty | Note |
|-------|----------|-----------------------|-------------|--------------------|-------------|------|------|
| 20 | 10328335 | Hex Socket Cap Screw | P330210011 | M5X30 | | 8 | |
| 21 | 10000806 | Urethane Clamper | 1230879 | | | 4 | |
| 22 | 10339118 | Hex Socket Cap Screw | P330230015 | M8X65 | | 2 | |
| 23 | 10589279 | Conical Spring Washer | P336165002 | CDW-8H | HHK | 2 | |
| 24 | 10339063 | Square Nut | 1230880 | | | 2 | |
| 25 | 10339006 | Hydraulic Hose | 1280786 | | | 1 | |
| 26 | 10339007 | Hydraulic Hose | 1280787 A | | | 1 | |
| 27 | 10380807 | Hose Adapter | P589227018 | 045-4-4 | NITTA MOORE | 2 | |
| 28 | 10000818 | Multi-vise Stand | 1230883 | | | 4 | |
| 29 | 10000913 | Domed Cap Nut | 0018038 A | | | 4 | |
| 30 | 10338954 | Name Plate | 1230888 | | | 1 | |
| 31 | 10589430 | Quick Connect Joint | P589026081 | 2S-BSBM | NITTO KOHKI | 2 | |
| 32 | 10001010 | Rubber Plug | 0636994 | | | 2 | |
| 33 | 10300613 | Chain | RB0054035- | L=150 | | 2 | |
| 34 | 10329430 | Split Pin | P337000034 | 3.2X22(Mild Steel) | JIS | 2 | |
| 35 | 10375463 | Cable Band | P381058035 | SKB-2M | KITAGAWA | 2 | |

Unit No. 88
Cover Open LS(1)

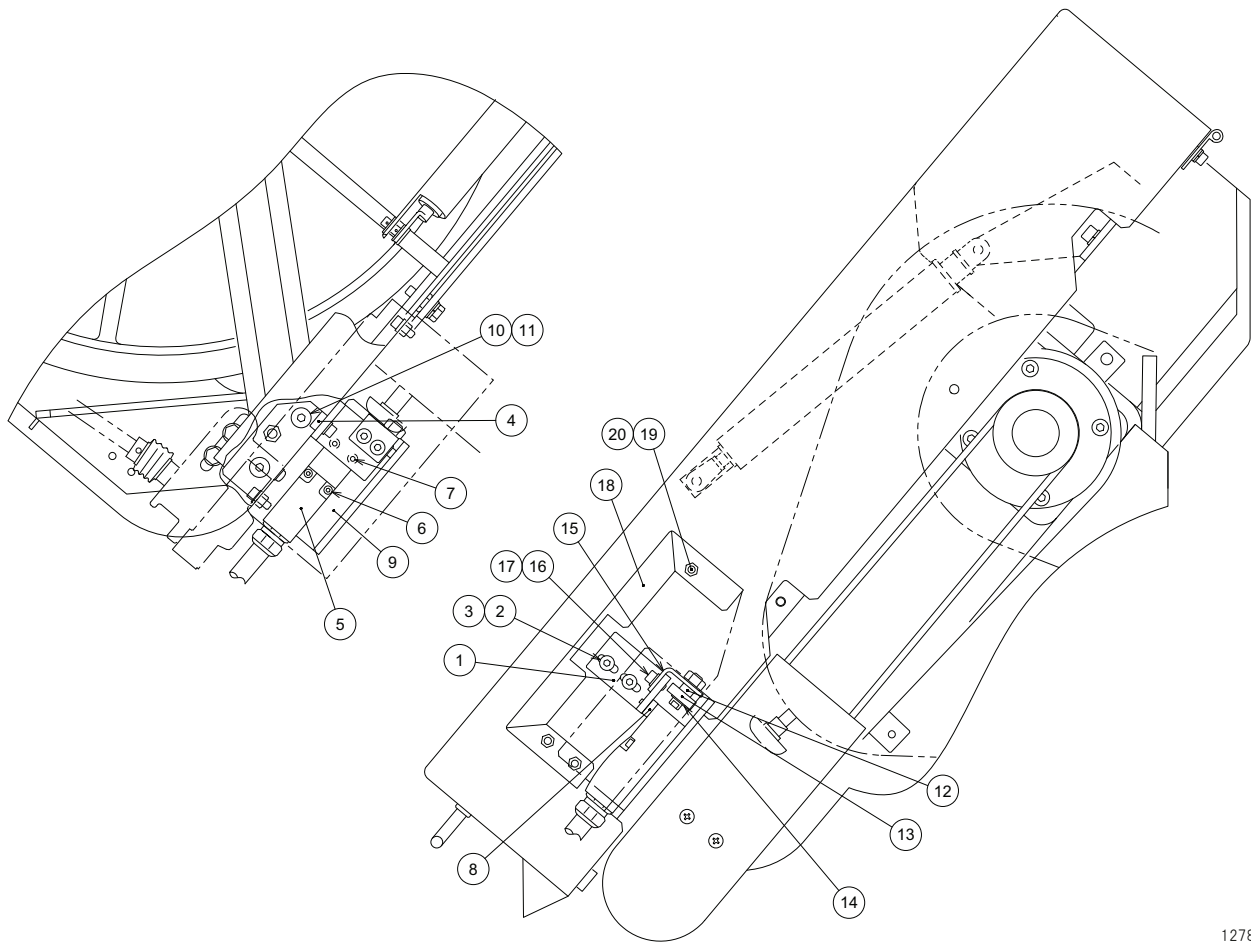

Unit No. 88
Cover Open LS(1)

| Index | Code | Parts Name | Drawing No. | Type | Maker | Q'ty | Note |
|-------|----------|--------------------------|-------------|-----------|---------------|------|------|
| 1 | 10301502 | Bracket | RB02338--- | | | 1 | |
| 2 | 10312831 | Hex Socket Cap Screw | P330220006 | M6X15 | | 2 | |
| 3 | 10321922 | Washer | P336000005 | 6(Normal) | JIS | 2 | |
| 4 | 10583711 | Square Nut | 1230689 A | | | 1 | |
| 5 | 10300206 | Limit Switch | P828008008 | LS-11-ZB | MURA Electric | 1 | |
| 6 | 10359526 | Hex Socket Cap Screw | P330200023 | M4X30 | | 2 | |
| 7 | 10300139 | Flat Head Screw | P334110009 | M4X12 | JIS | 2 | |
| 8 | 10330110 | Accessory for Conduit | P866103001 | OA-1 | OHM Electric | 1 | |
| 9 | 10583713 | LS Bracket | 1230861 A | | | 1 | |
| 10 | 10342325 | Hex Socket Cap Screw | P330230004 | M8X15 | | 2 | |
| 11 | 10321923 | Washer | P336000006 | 8(Normal) | JIS | 2 | |
| 12 | 10583714 | Shaft | 1230863 A | | | 1 | |
| 13 | 10301290 | Deep Groove Ball Bearing | P400010725 | 6000ZZ | NSK(equality) | 1 | |
| 14 | 10205431 | Locating Snap Ring | P406108033 | STW-10 | OCHIAI | 1 | |
| 15 | 10583715 | Bracket | 1230859 | | | 1 | |
| 16 | 10323201 | Hex Socket Cap Screw | P330220004 | M6X12 | JIS | 2 | |
| 17 | 10321922 | Washer | P336000005 | 6(Normal) | JIS | 2 | |
| 18 | 10583716 | Cover | 1230860 B | | | 1 | |
| 19 | 10312831 | Hex Socket Cap Screw | P330220006 | M6X15 | | 3 | |

Unit No. 88
Cover Open LS(1)

| Index | Code | Parts Name | Drawing No. | Type | Maker | Q'ty | Note |
|-------|----------|------------|-------------|-----------|-------|------|------|
| 20 | 10321922 | Washer | P336000005 | 6(Normal) | JIS | 3 | |

Unit No. 89
Cover Open LS(2) <EU Specification Machine>

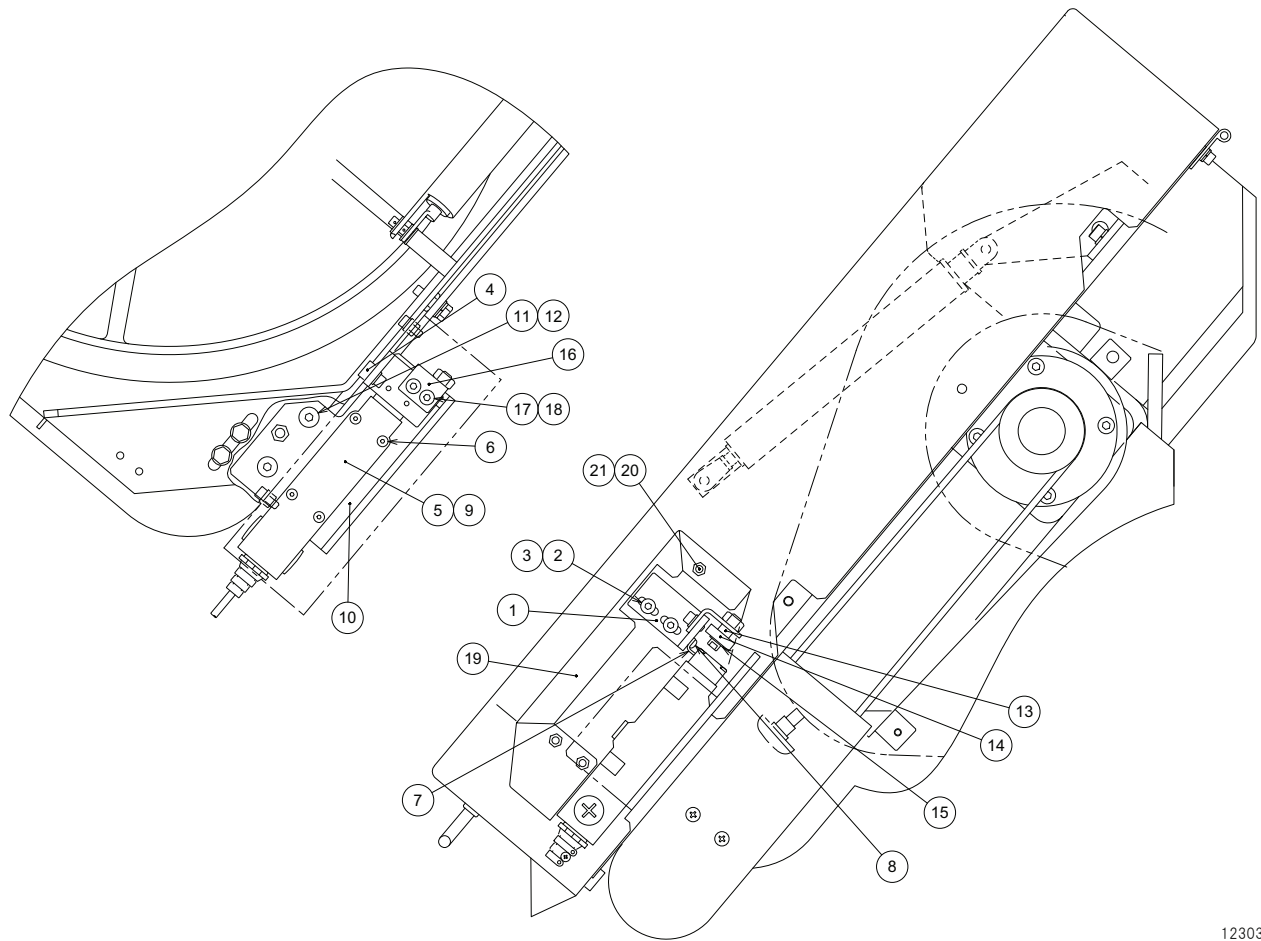

1230327

Unit No. 89
Cover Open LS(2)

| Index | Code | Parts Name | Drawing No. | Type | Maker | Q'ty | Note |
|-------|----------|--------------------------|-------------|--------------------------|---------------|------|------|
| 1 | 10583710 | Bracket | 1230858 | | | 1 | |
| 2 | 10312831 | Hex Socket Cap Screw | P330220006 | M6X15 | | 2 | |
| 3 | 10321922 | Washer | P336000005 | 6(Normal) | JIS | 2 | |
| 4 | 10583711 | Square Nut | 1230689 A | | | 1 | |
| 5 | 10301312 | Door Switch | P829602030 | D4GL-2AFA-A | OMRON | 1 | |
| 6 | 10418224 | Hex Socket Cap Screw | P330200021 | M4X20 | | 2 | |
| 7 | 10589517 | Key for Switch | P829602008 | D4DS-K2 (Key for Switch) | OMRON | 1 | |
| 8 | 10337027 | Pan Head Screw | P334100018 | M4X10 | JIS | 2 | |
| 9 | 10330110 | Accessory for Conduit | P866103001 | OA-1 | OHM Electric | 1 | |
| 10 | 10301167 | LS Bracket | 1230983 | | | 1 | |
| 11 | 10342325 | Hex Socket Cap Screw | P330230004 | M8X15 | | 2 | |
| 12 | 10321923 | Washer | P336000006 | 8(Normal) | JIS | 2 | |
| 13 | 10583714 | Shaft | 1230863 A | | | 1 | |
| 14 | 10301290 | Deep Groove Ball Bearing | P400010725 | 6000ZZ | NSK(equality) | 1 | |
| 15 | 10205431 | Locating Snap Ring | P406108033 | STW-10 | OCHIAI | 1 | |
| 16 | 10583715 | Bracket | 1230859 | | | 1 | |
| 17 | 10323201 | Hex Socket Cap Screw | P330220004 | M6X12 | JIS | 2 | |
| 18 | 10321922 | Washer | P336000005 | 6(Normal) | JIS | 2 | |
| 19 | 10301168 | Cover | 1230984 | | | 1 | |

Unit No. 89
Cover Open LS(2)

| Index | Code | Parts Name | Drawing No. | Type | Maker | Q'ty | Note |
|-------|----------|----------------------|-------------|-----------|-------|------|------|
| 20 | 10312831 | Hex Socket Cap Screw | P330220006 | M6X15 | | 3 | |
| 21 | 10321922 | Washer | P336000005 | 6(Normal) | JIS | 3 | |

Unit No. 90
Vise Pressure Control Valve(1)

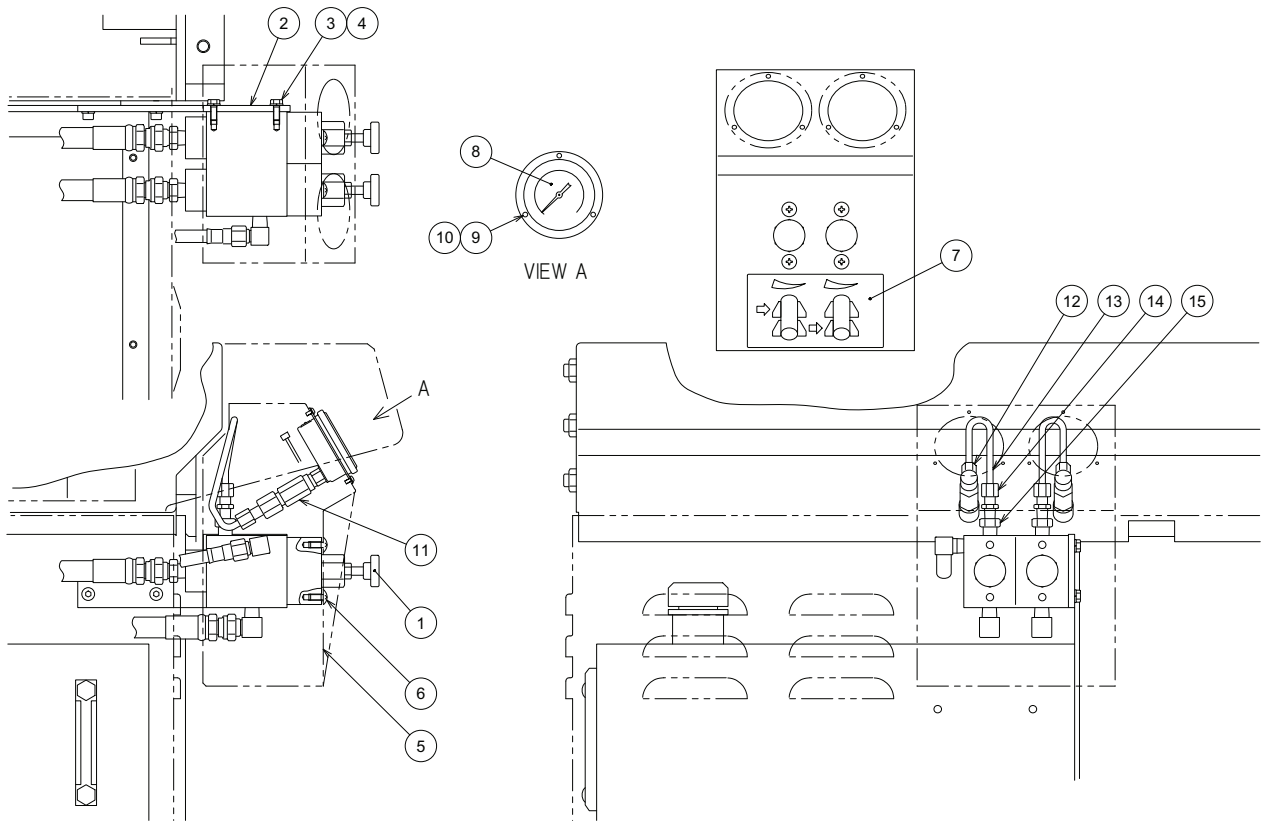

Unit No. 90

Vise Pressure Control Valve(1)

| Index | Code | Parts Name | Drawing No. | Type | Maker | Q'ty | Note |
|-------|----------|-------------------------------------|-------------|----------------------|---------------|------|------|
| 1 | 10389958 | Vise Pressure Control Valve | 7922858 A | YV-1221-3 | YUATSU SEIKO | 1 | |
| 2 | 10301145 | Vise Pressure Control Valve Bracket | 1108719--- | | | 1 | |
| 3 | 10323204 | Hex Socket Cap Screw | P330220007 | M6X16 | JIS | 4 | |
| 4 | 10310351 | Spring Washer | P336050005 | 6 | JIS | 4 | |
| 5 | 10301144 | Vise Pressure Control Valve Cover | 1108717--B | | | 1 | |
| 6 | 10340019 | Truss Head Screw | P334130012 | M6X12 | JIS | 4 | |
| 7 | 10340608 | Name Plate | 1230899 | | | 1 | |
| 8 | 10301277 | Pressure Gauge | 7922943 B | OPGDFT-G1/4-60X10MPA | ASK | 2 | |
| 9 | 10328312 | Pan Head Screw | P334100003 | M3X6 | JIS | 6 | |
| 10 | 10338205 | Spring Washer | P336050002 | 3 | JIS | 6 | |
| 11 | 10328959 | Gauge Damper | P549018003 | SA-100-2 | ASK | 2 | |
| 12 | 10485332 | Bite Type Pipe Fitting | P585520003 | KSP-1/4X6-B | IHARA Science | 2 | |
| 13 | 10380810 | Copper Pipe | QZZ036563 | D4XD6XL150 | | 1 | |
| 14 | 10301300 | Bite Type Pipe Fitting | P585538014 | KC6-R1/8-B | IHARA Science | 2 | |
| 15 | 10416703 | Bush for Piping | P580010001 | 1/4X1/8 | JIS | 2 | |

Unit No. 91
Vise Pressure Control Valve(2) <Plugging Plate>

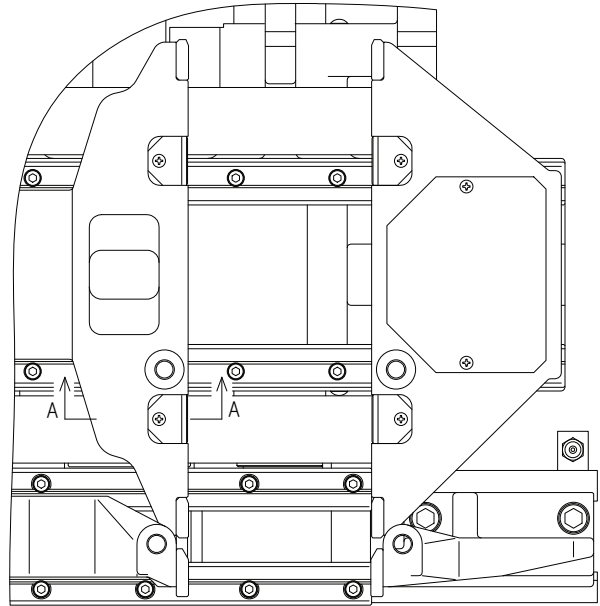
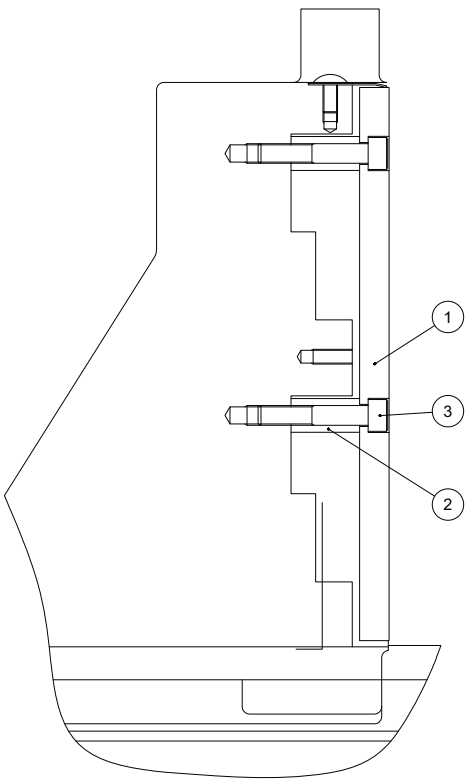

1238676

Unit No. 91

Vise Pressure Control Valve(2)

| Index | Code | Parts Name | Drawing No. | Type | Maker | Q'ty | Note |
|-------|----------|----------------------|-------------|-------|-------|------|------|
| 1 | 10380830 | Plate | 1238506 A | | | 4 | |
| 2 | 10380831 | Collar | 1238507 A | | | 8 | |
| 3 | 10323203 | Hex Socket Cap Screw | P330230011 | M8X45 | | 8 | |

Unit No. 92
 Vise Pressure Control Valve(3) <Piping>

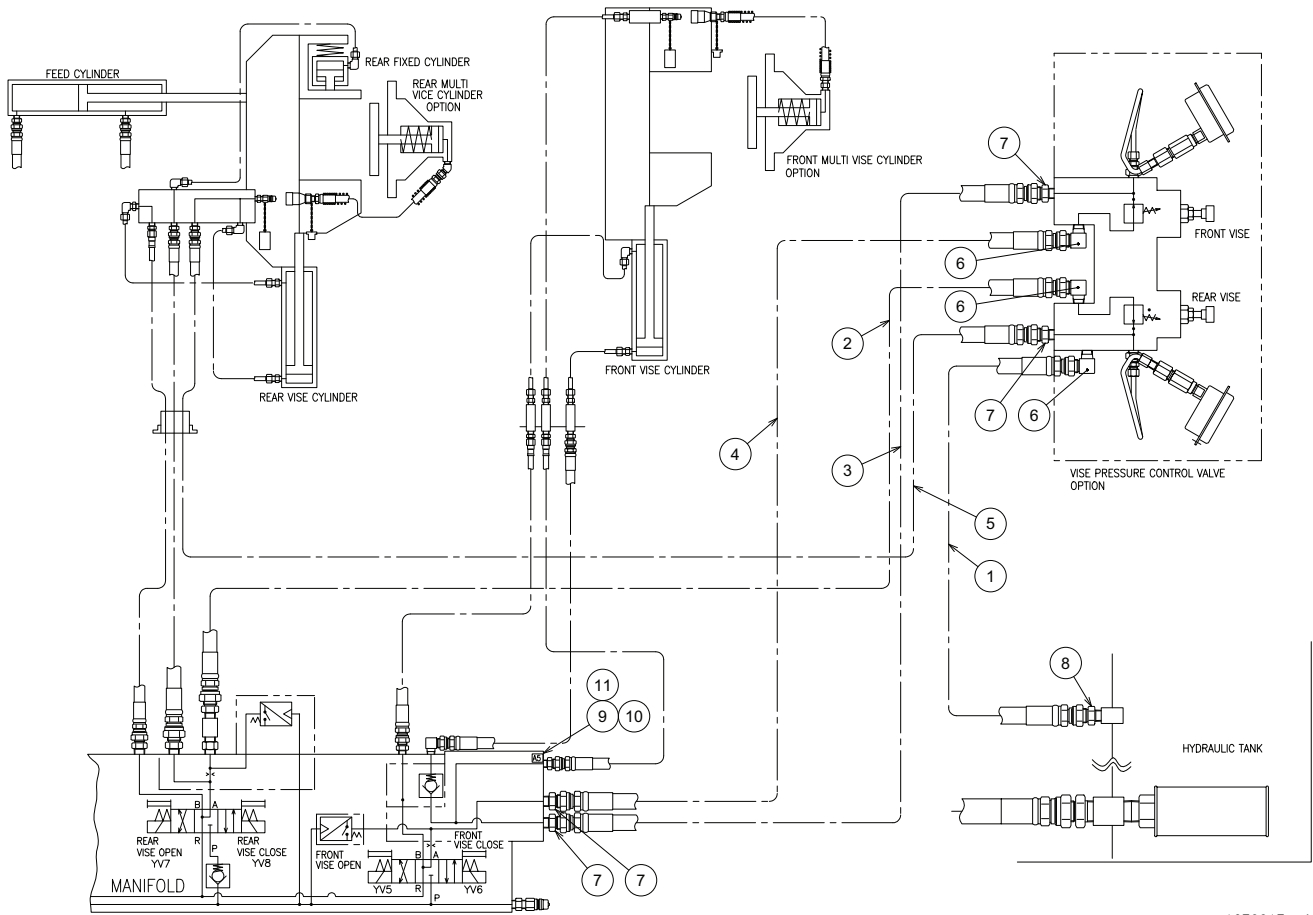

1278817--A

Unit No. 92

Vise Pressure Control Valve(3)

| Index | Code | Parts Name | Drawing No. | Type | Maker | Q'ty | Note |
|-------|----------|---------------------------------------|-------------|-------------|-------|------|------|
| 1 | 10380814 | Hydraulic Hose | 1238661 | 3/8X1070 | | 1 | |
| 2 | 10380815 | Hydraulic Hose | 1238662 | 3/8X1500 | | 1 | |
| 3 | 10380816 | Hydraulic Hose | 1238663 | 3/8X900 | | 1 | |
| 4 | 10380817 | Hydraulic Hose | 1238664 | 3/8X870 | | 1 | |
| 5 | 10583736 | Hydraulic Hose | 1230323 | 3/8X2800 | | 1 | |
| 6 | 10301126 | Elbow | RB0198903- | PT1/4-PF3/8 | | 3 | |
| 7 | 10300597 | Male-Male Adapter | RB0054013B | PT1/4-PF3/8 | | 4 | |
| 8 | 10300598 | Male-Male Adapter | RB0054014A | PT3/8-PF3/8 | | 1 | |
| 9 | 10376779 | Vise Pressure Control Valve Sub Plate | 1108739 A | | | 1 | |
| 10 | 10314519 | O Ring | P590000007 | P9 | | 4 | |
| 11 | 10372068 | Hex Socket Cap Screw | P330210021 | M5X130 | MOURI | 4 | |

Unit No. 93
Blade Deviation Monitor(1)-1/2

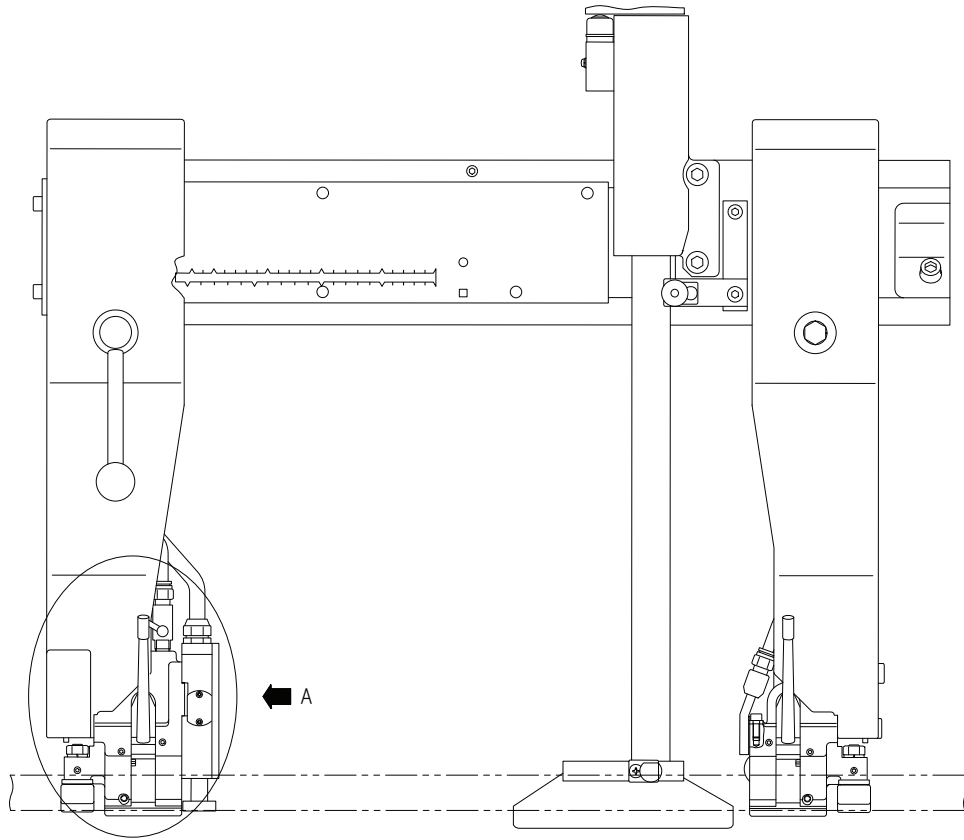

1278820--A

Unit No. 93
Blade Deviation Monitor(1)-2/2

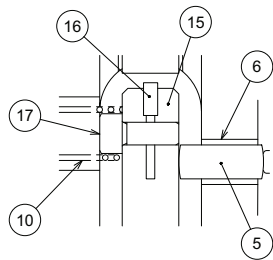

DETAIL C

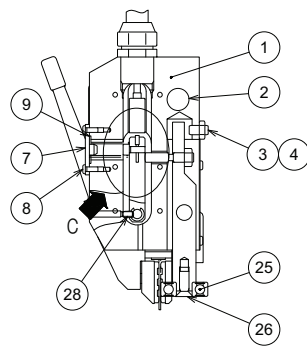

SECTION B-B

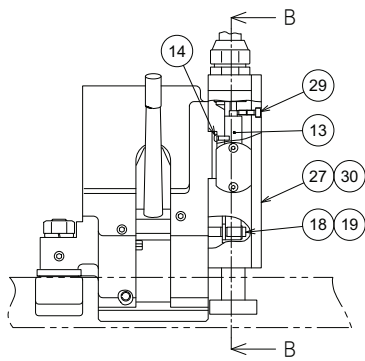

DETAIL A

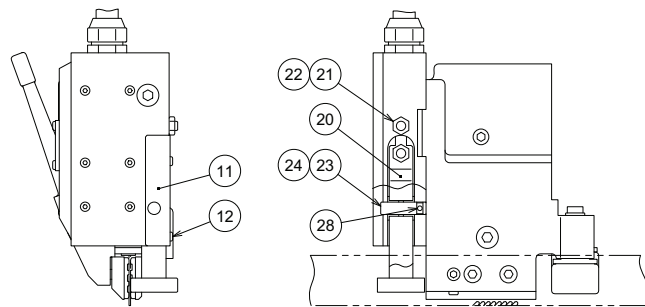

Unit No. 93

Blade Deviation Monitor(1)

| Index | Code | Parts Name | Drawing No. | Type | Maker | Q'ty | Note |
|-------|----------|----------------------|-------------|------------------------|----------------------------|------|------|
| 1 | 10383306 | Detector Body | 1238637 B | | | 1 | |
| 2 | 10330101 | Hex Socket Cap Screw | P330230008 | M8X30 | | 2 | |
| 3 | 10328344 | Socket Set Screw | P330550027 | M6X12(Flat Type) | JIS | 1 | |
| 4 | 10589225 | Nut | P332000004 | M6 | JIS | 1 | |
| 5 | 10327861 | Push Pin | 1200856 | | | 1 | |
| 6 | 10485317 | Plain Bearing | P407003136 | DUB0610 | DAIDO METAL | 1 | |
| 7 | 10327946 | Cover | 1200857 | | | 1 | |
| 8 | 10379619 | Button Head Screw | P334500045 | M3X8 | JIS | 2 | |
| 9 | 10328354 | O Ring | P590032013 | S15 | NOK | 1 | |
| 10 | 10328232 | Spring | 1231299 | | | 1 | |
| 11 | 10377121 | Cover | 1238644 | | | 1 | |
| 12 | 10379619 | Button Head Screw | P334500045 | M3X8 | JIS | 2 | |
| 13 | 10328404 | Accessory for Sensor | P829158001 | PH-11 | Sony Systems Manufacturing | 1 | |
| 14 | 10583802 | Pan Head Screw | P334000001 | M2.5X8(Slotting)-C2700 | JIS | 2 | |
| 15 | 10327855 | Magnet Holder | 1200853 | | | 1 | |
| 16 | 10328401 | Accessory for Sensor | P829158002 | PG-9010 | Sony Systems Manufacturing | 1 | |
| 17 | 10328334 | Hex Socket Cap Screw | P330200015 | M4X10 | | 1 | |
| 18 | 10327857 | Hinge Pin | 1200854 | | | 1 | |
| 19 | 10377564 | Locating Snap Ring | P406108078 | ETW-4 | OCHIAI | 1 | |

Unit No. 93

Blade Deviation Monitor(1)

| Index | Code | Parts Name | Drawing No. | Type | Maker | Q'ty | Note |
|-------|----------|--------------------------|-------------|-------------------|--------------|------|------|
| 20 | 10327938 | Detector Lever | 1231300 | | | 1 | |
| 21 | 10301569 | Socket Set Screw | P330570019 | M6X16(Dog-end) | JIS | 1 | |
| 22 | 10589225 | Nut | P332000004 | M6 | JIS | 1 | |
| 23 | 10301571 | Plain Bearing | P407013039 | DUF0806-15 | DAIDO METAL | 2 | |
| 24 | 10327858 | Hinge Pin | 1200861 | | | 1 | |
| 25 | 10319322 | Deep Groove Ball Bearing | P400010539 | 6200DDU | NSK & others | 1 | |
| 26 | 10328360 | Flat Head Bolt | P334520001 | M6X15 | NISSAN NEJI | 1 | |
| 27 | 10377119 | Plate | 1238636 | | | 1 | |
| 28 | 10328343 | Socket Set Screw | P330590003 | M3X6(Dimple Type) | JIS | 2 | |
| 29 | 10338301 | Hex Socket Cap Screw | P330200002 | M3X8 | | 6 | |
| 30 | 10327943 | Packing | 1231297 | | | 1 | |

Unit No. 94
 Blade Deviation Monitor(2) <Blade Deviation Corrector>

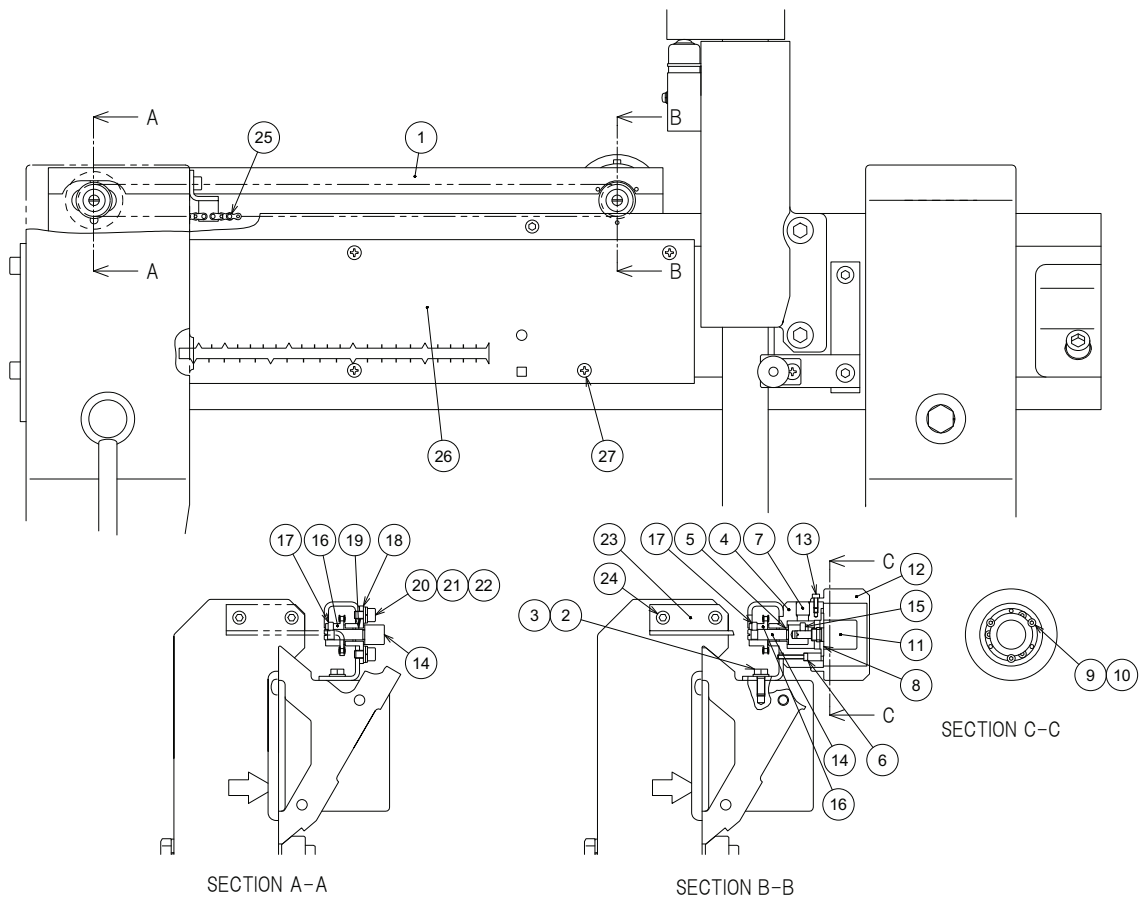

1278821--A

Unit No. 94

Blade Deviation Monitor(2)

| Index | Code | Parts Name | Drawing No. | Type | Maker | Q'ty | Note |
|-------|----------|-----------------------|-------------|-------------------|-------------------|------|------|
| 1 | 10379627 | Chain Guide Body | 1238645 A | | | 1 | |
| 2 | 10371906 | Bolt | P330020006 | M6X16 | JIS | 2 | |
| 3 | 10310351 | Spring Washer | P336050005 | 6 | JIS | 2 | |
| 4 | 10328041 | Potentiometer Housing | 1200868 | | | 1 | |
| 5 | 10301571 | Plain Bearing | P407013039 | DUF0806-15 | DAIDO METAL | 2 | |
| 6 | 10328333 | Hex Socket Cap Screw | P330200009 | M3X20 | | 3 | |
| 7 | 10328210 | Socket Set Screw | P330550048 | M10X10(Flat Type) | JIS | 1 | |
| 8 | 10328043 | Flange | 1200869 | | | 1 | |
| 9 | 10338301 | Hex Socket Cap Screw | P330200002 | M3X8 | | 3 | |
| 10 | 10328309 | Washer | P336000002 | 3(Small Round) | JIS | 3 | |
| 11 | 10379631 | Potentiometer | P729108001 | MF220(10 kOhm) | Nippon Servo | 1 | |
| 12 | 10328045 | Potentiometer Cover | 1200870 | | | 1 | |
| 13 | 10338301 | Hex Socket Cap Screw | P330200002 | M3X8 | | 3 | |
| 14 | 10419578 | Sprocket Shaft | 1244669 | | | 2 | |
| 15 | 10328341 | Socket Set Screw | P330550009 | M4X6(Flat Type) | JIS | 1 | |
| 16 | 10583803 | Sprocket Wheel | 1238647 | RS25-1B-12T | TSUBAKIMOTO CHAIN | 2 | |
| 17 | 10328341 | Socket Set Screw | P330550009 | M4X6(Flat Type) | JIS | 2 | |
| 18 | 10328047 | Tension | 1200871 | | | 1 | |
| 19 | 10301571 | Plain Bearing | P407013039 | DUF0806-15 | DAIDO METAL | 2 | |

Unit No. 94

Blade Deviation Monitor(2)

| Index | Code | Parts Name | Drawing No. | Type | Maker | Q'ty | Note |
|-------|----------|-------------------------|-------------|-----------|-------|------|------|
| 20 | 10557024 | Button Head Screw | P334500013 | M6X10 | | 2 | |
| 21 | 10310351 | Spring Washer | P336050005 | 6 | JIS | 2 | |
| 22 | 10321922 | Washer | P336000005 | 6(Normal) | JIS | 2 | |
| 23 | 10379628 | Chain Guide | 1238646 A | | | 1 | |
| 24 | 10312831 | Hex Socket Cap Screw | P330220006 | M6X15 | | 2 | |
| 25 | 10379626 | Roller Chain | 1238640 A | | | 1 | |
| 26 | 10419396 | Plate (Runout Detector) | 1238643 D | | | 1 | |
| 27 | 10322226 | Pan Head Screw | P334100055 | M6X12 | JIS | 6 | |

Unit No. 95
Blade Deviation Monitor(3)-1/2 <Electric>

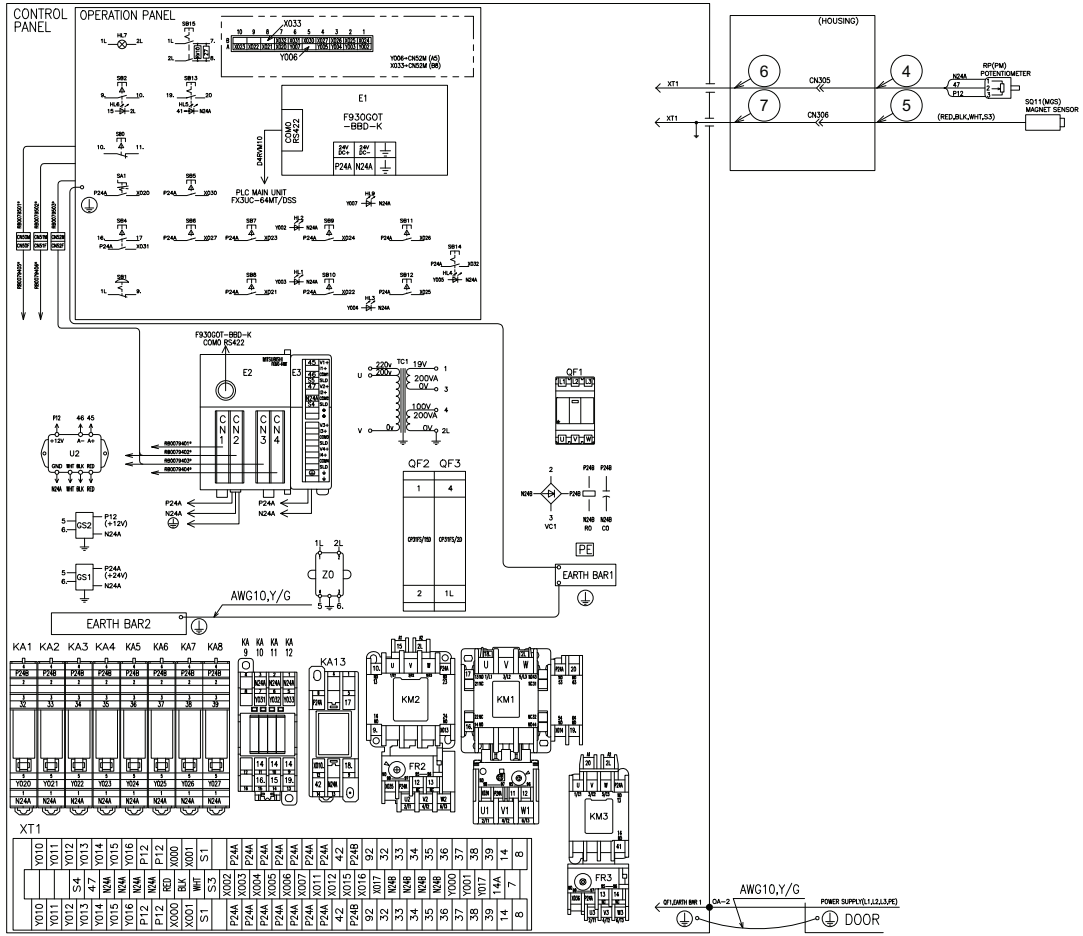

RB02290---
(RB02501--D)

Unit No. 95
 Blade Deviation Monitor(3)-2/2 <Electric>

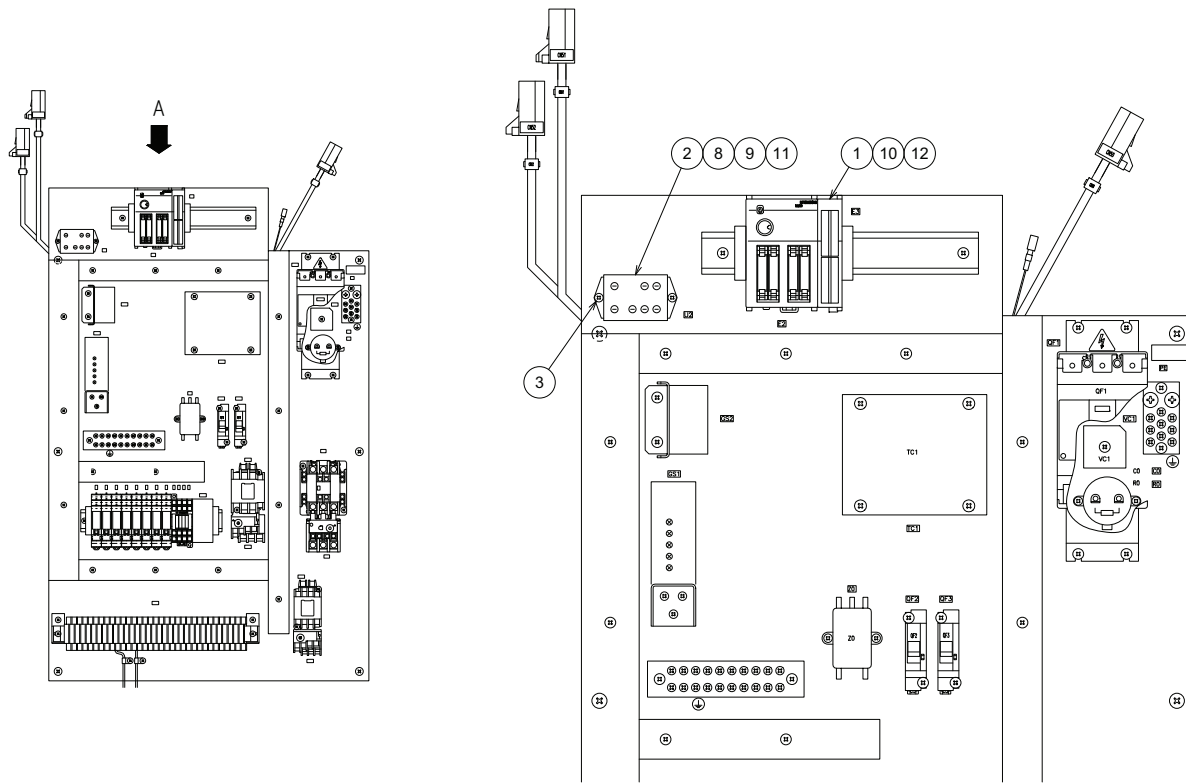

DETAIL A

RB02290---
 (RB01579--C)

Unit No. 95

Blade Deviation Monitor(3)

| Index | Code | Parts Name | Drawing No. | Type | Maker | Q'ty | Note |
|-------|----------|------------------------------|-------------|------------------------------|-------------------------------|------|------|
| 1 | 10579289 | Program Controller Module | P767476031 | FX2NC-4AD | MITSUBISHI | 1 | E3 |
| 2 | 10579294 | Accessory for Sensor | P829158003 | PD-10 | Sony Manufacturing Systems | 1 | U2 |
| 3 | 10589250 | Sems Pan Head Screw | P334200010 | M3X10(Spring/Polished Round) | JIS | 2 | |
| 4 | 10301974 | Potentiometer | RB0153861A | | | 1 | |
| 5 | 10301975 | Magnet Sensor | RB0153862A | | | 1 | |
| 6 | 10301976 | Potentiometer Junction Cable | RB0153863A | | | 1 | |
| 7 | 10301977 | Magnet Sensor Junction Cable | RB0153864A | | | 1 | |
| 8 | 10301664 | Power Cable | RB0079411- | | | 1 | |
| 9 | 10301665 | Magnet Sensor Cable | RB0079412A | | | 1 | |
| 10 | 10301666 | Potentiometer Cable | RB0079413- | | | 1 | |
| 11 | 10301667 | Analog SIG Cable | RB0079414A | | | 1 | |
| 12 | 10301668 | Ground Cable | RB0079415- | | | 1 | |

Unit No. 96
Roller Stand

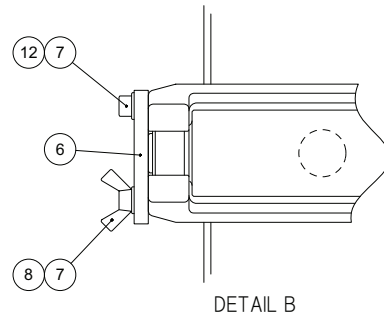
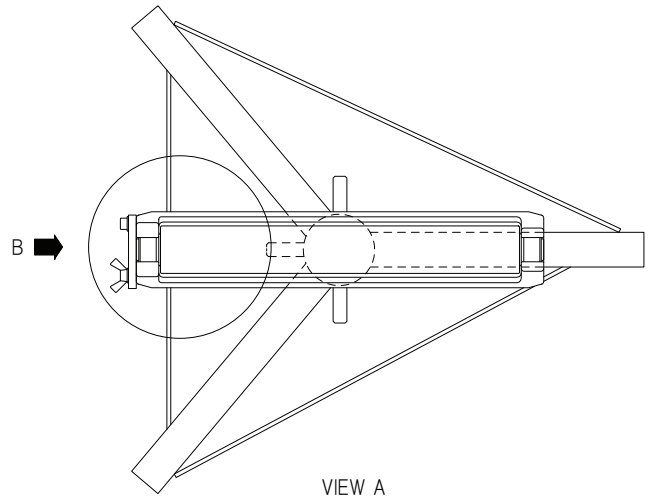
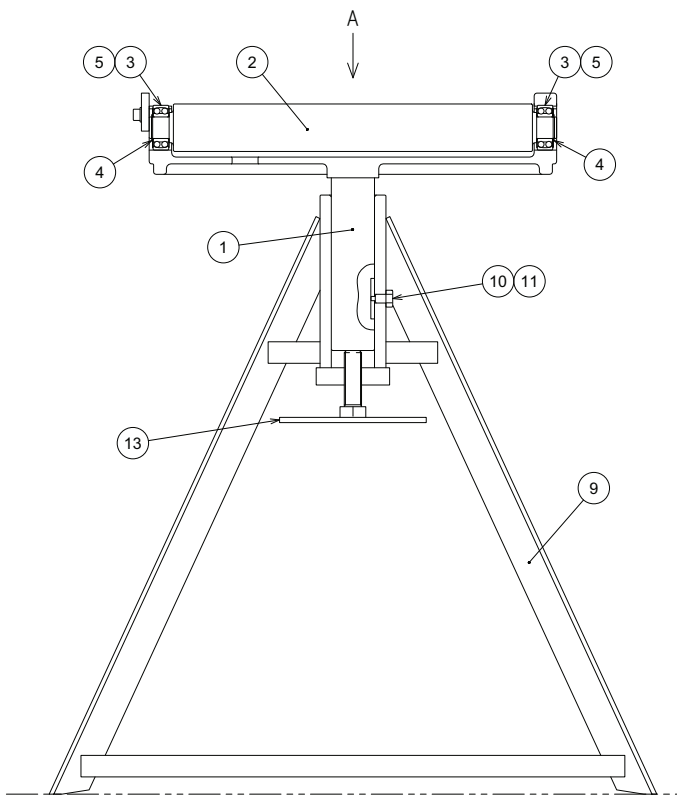

Unit No. 96

Roller Stand

| Index | Code | Parts Name | Drawing No. | Type | Maker | Q'ty | Note |
|-------|----------|----------------------|-------------|-----------------|--------------|------|------|
| 1 | 10419581 | Roller Support | 0602641 A | | | 1 | |
| 2 | 10419582 | Roller | 0603129 C | | | 1 | |
| 3 | 10380846 | Ball Bearing | P400070511 | 2205 | NSK & others | 2 | |
| 4 | 10380847 | Locating Snap Ring | P406100024 | for shaftC-25 | JIS | 2 | |
| 5 | 10419583 | Seal Plate | 0603130 C | | | 4 | |
| 6 | 10419584 | Stopper | 0602642 A | | | 1 | |
| 7 | 10321923 | Washer | P336000006 | 8(Normal) | JIS | 2 | |
| 8 | 10380845 | Wing Bolt | P338020006 | Type-1M8X20 | JIS | 1 | |
| 9 | 10419585 | Roller Stand | 1200682 A | | | 1 | |
| 10 | 10340917 | Socket Set Screw | P330570034 | M10X25(Dog-end) | JIS | 1 | |
| 11 | 10427991 | Nut | P332000006 | M10 | JIS | 1 | |
| 12 | 10322202 | Hex Socket Cap Screw | P330230006 | M8X20 | | 1 | |
| 13 | 10583738 | Handle Bolt | 0602645 A | | | 1 | |

Unit No. 97
 Roller Table-1/2

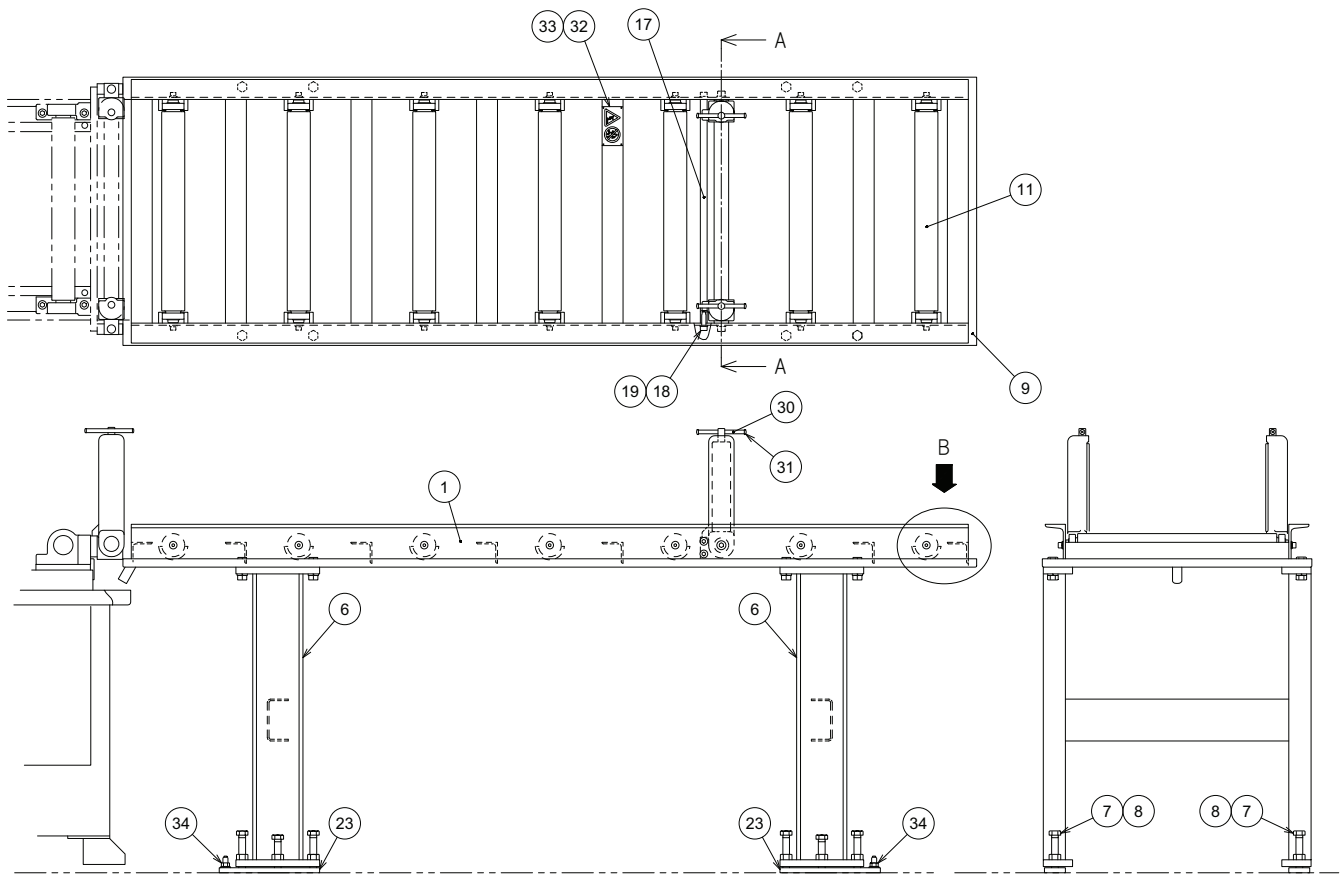

1278892--A

Unit No. 97
Roller Table-2/2

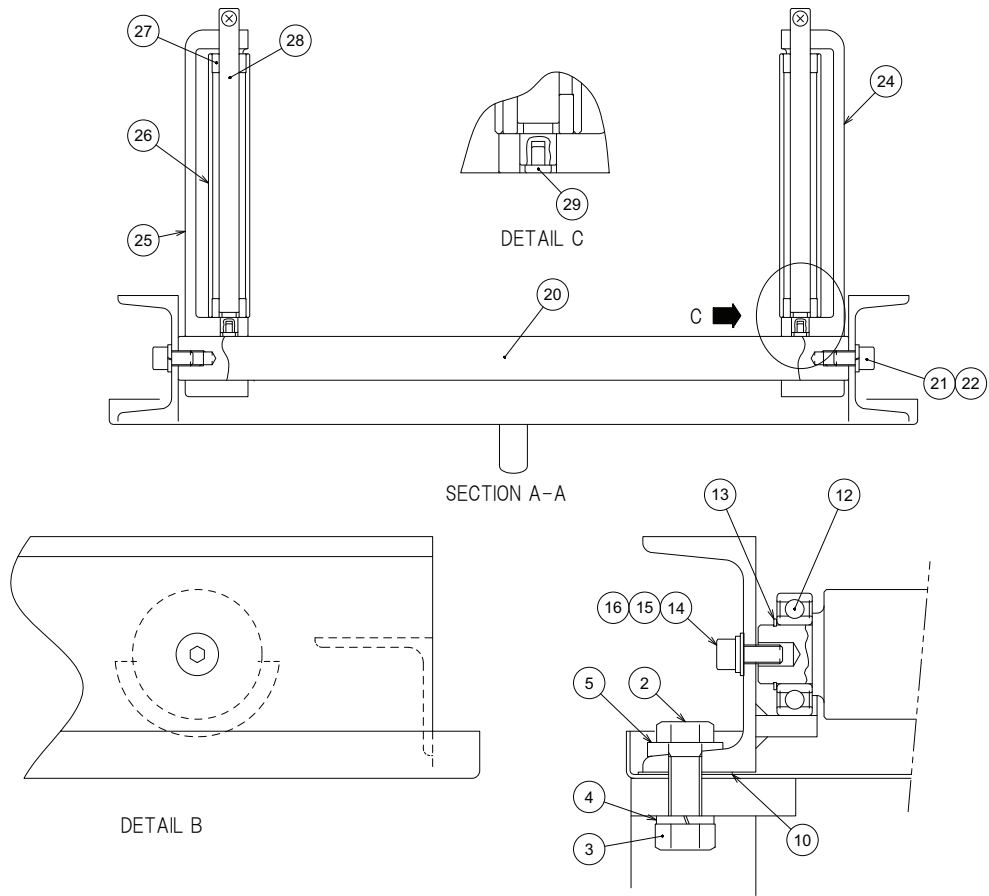

Unit No. 97

Roller Table

| Index | Code | Parts Name | Drawing No. | Type | Maker | Q'ty | Note |
|-------|----------|--------------------------|-------------|--------------------|-------------|------|------|
| 1 | 10301492 | Roller Support Base | RB02311--A | | | 1 | |
| 2 | 10322260 | Bolt | P330060004 | M14X45 | JIS | 8 | |
| 3 | 10000826 | Nut | P332000008 | M14 | JIS | 8 | |
| 4 | 10000825 | Spring Washer | P336050009 | 14 | JIS | 8 | |
| 5 | 10376120 | Beveled Washer | P336210009 | 12-5 Deg. | Tokyo Byora | 8 | |
| 6 | 10301496 | Stand | RB02312--A | | | 2 | |
| 7 | 10385469 | Bolt | P330060031 | M16X80(All-thread) | MOURI | 12 | |
| 8 | 10421756 | Nut | P332000009 | M16 | JIS | 12 | |
| 9 | 10419588 | Oil Pan | 0637213 A | | | 1 | |
| 10 | 10419589 | Packing | 1200654 A | | | 4 | |
| 11 | 10419590 | Roller | 0637214 A | | | 7 | |
| 12 | 10341319 | Deep Groove Ball Bearing | P400017025 | 6205DDU | NSK | 14 | |
| 13 | 10310821 | Locating Snap Ring | P406108046 | STW-25 | OCHIAI | 14 | |
| 14 | 10322202 | Hex Socket Cap Screw | P330230006 | M8X20 | | 14 | |
| 15 | 10001521 | Spring Washer | P336050006 | 8 | JIS | 14 | |
| 16 | 10321923 | Washer | P336000006 | 8(Normal) | JIS | 14 | |
| 17 | 10419591 | Stopper Plate | 0637215 A | | | 1 | |
| 18 | 10341713 | Hex Socket Cap Screw | P330240006 | M10X20 | | 4 | |
| 19 | 10001520 | Spring Washer | P336050007 | 10 | JIS | 4 | |

Unit No. 97

Roller Table

| Index | Code | Parts Name | Drawing No. | Type | Maker | Q'ty | Note |
|-------|----------|-------------------------|-------------|----------|------------------|------|------|
| 20 | 10419592 | Guide Bar | 0637216 A | | | 1 | |
| 21 | 10329416 | Hex Socket Cap Screw | P330250003 | M12X20 | | 2 | |
| 22 | 10000829 | Spring Washer | P336050008 | 12 | JIS | 2 | |
| 23 | 10570050 | Anchor Plate | 1233671 | | | 4 | |
| 24 | 10380765 | Roller Bracket Left | 1238583 A | | | 1 | |
| 25 | 10380764 | Roller Bracket Right | 1238582 A | | | 1 | |
| 26 | 10378563 | Roller | 1238585 | | | 2 | |
| 27 | 10301139 | Shaft Support | 0603310--A | | | 4 | |
| 28 | 10378562 | Vertical Roller Set Bar | 1238584 | | | 2 | |
| 29 | 10301140 | Lock Piece | 0603312--A | | | 2 | |
| 30 | 10301141 | Handle | 0603314--C | | | 2 | |
| 31 | 10323219 | Pan Head Screw | P334100038 | M5X8 | JIS | 4 | |
| 32 | 10301136 | Warning Plate | RB0376651- | | | 1 | |
| 32 | 10301137 | Warning Plate | RB0376652- | | | 1 | |
| 32 | 10300085 | Warning Plate | 1109434 | | | 1 | |
| 33 | 10375027 | Drive Screw | P339100002 | NO.2X4.8 | Tokyo Byora | 4 | |
| 34 | 10589309 | Anchor | P338213005 | C-1290 | SANKO Technology | 4 | |

Unit No. 98
Head-end Positioning(1)

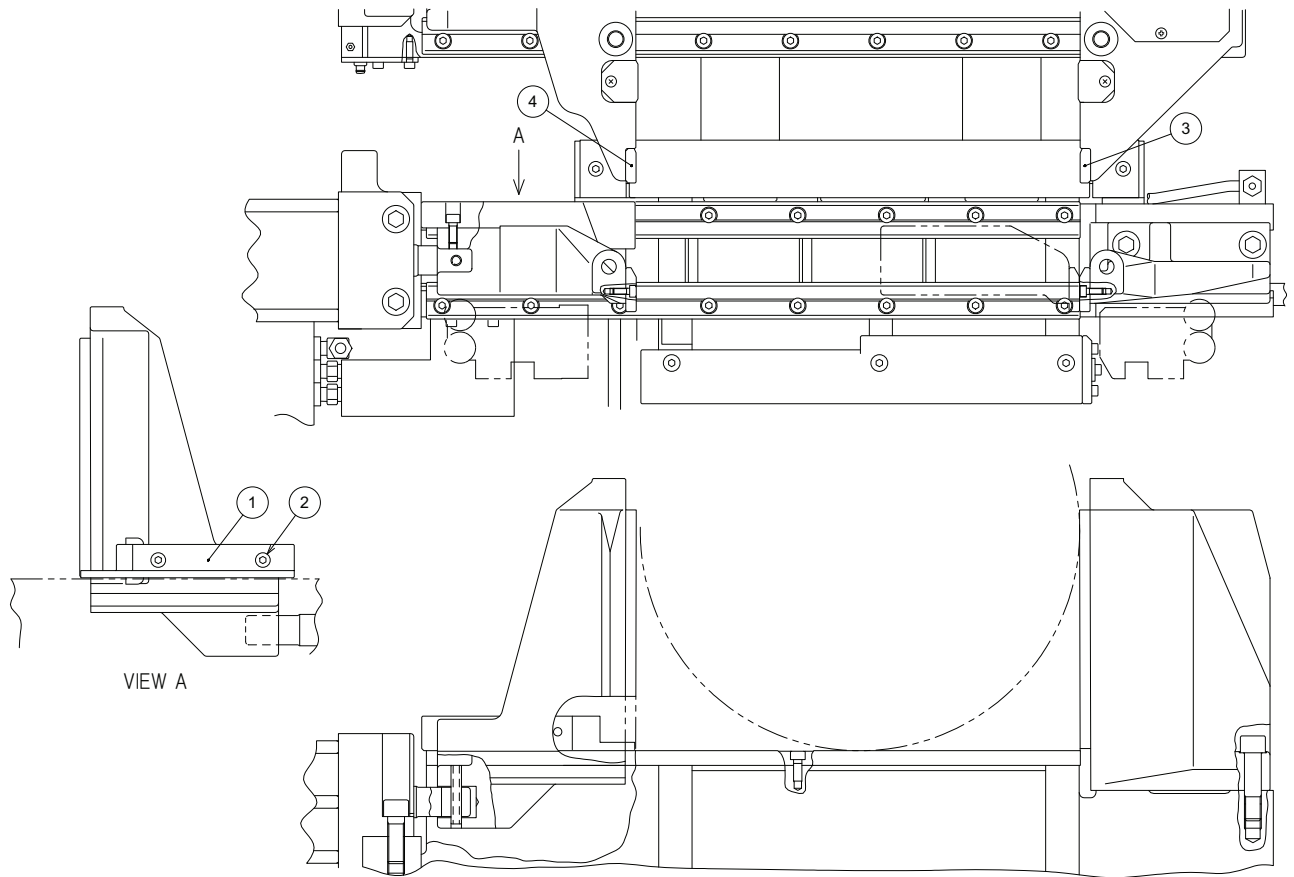

1278833--A

Unit No. 98

Head-end Positioning(1)

| Index | Code | Parts Name | Drawing No. | Type | Maker | Q'ty | Note |
|-------|----------|----------------------|-------------|-------|-------|------|------|
| 1 | 10419403 | Stopper Plate | 1238538 | | | 1 | |
| 2 | 10322202 | Hex Socket Cap Screw | P330230006 | M8X20 | | 4 | |
| 3 | 10419404 | Grooved Vise Plate | 1238539 | | | 1 | |
| 4 | 10380854 | Vise Plate | 1238481 B | | | 3 | |

Unit No. 99
Head-end Positioning(2) <Hydraulic>

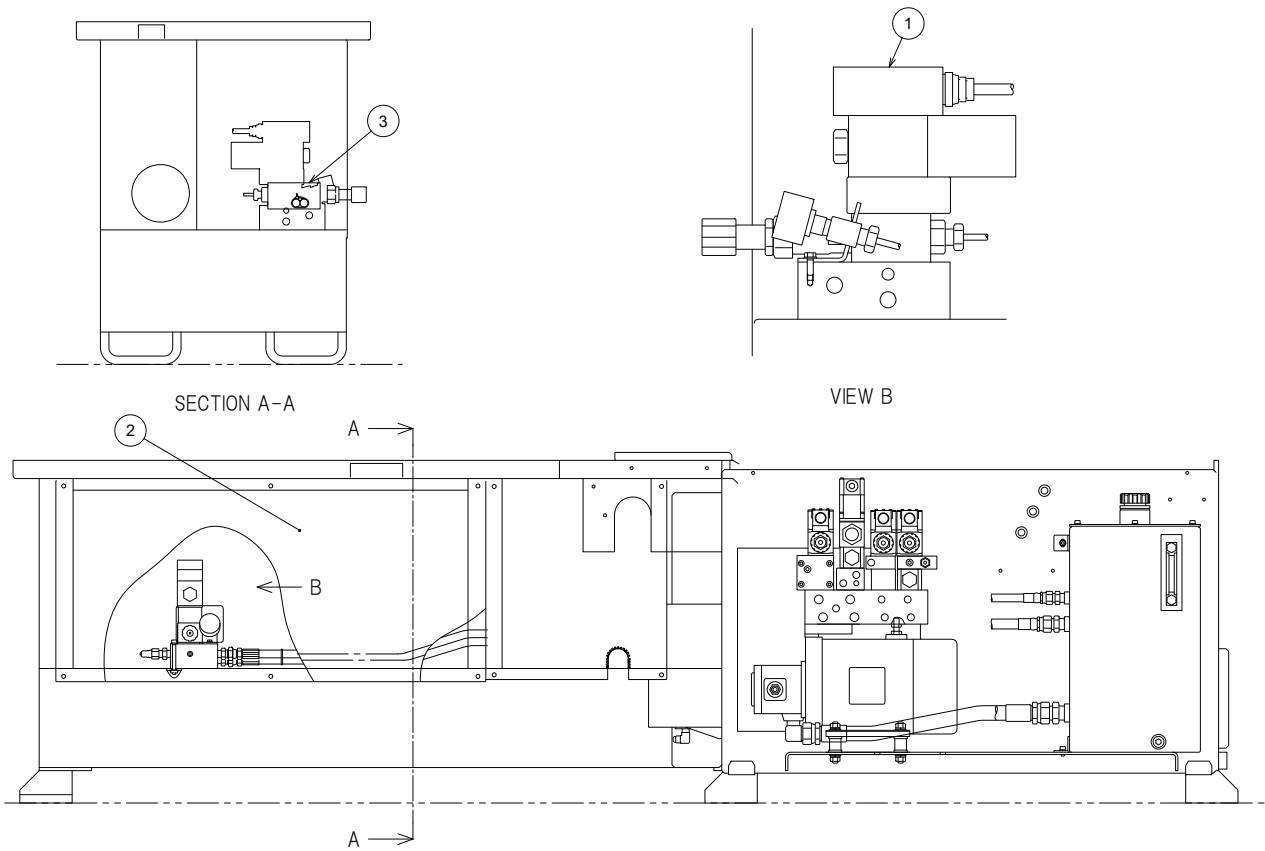

127882--B

Unit No. 99

Head-end Positioning(2)

| Index | Code | Parts Name | Drawing No. | Type | Maker | Q'ty | Note |
|-------|----------|-------------------|-------------|-------------|----------|------|------|
| 1 | 10301754 | Sub Manifold ASSY | RB01470--C | | | 1 | |
| 2 | 10583801 | Cover | 1230851 A | | | 1 | |
| 3 | 10375709 | Grommet | P229125056 | KG-032-0.3M | KITAGAWA | 1 | |

Unit No. 100
Head-end Positioning(3) <Sub-manifold>

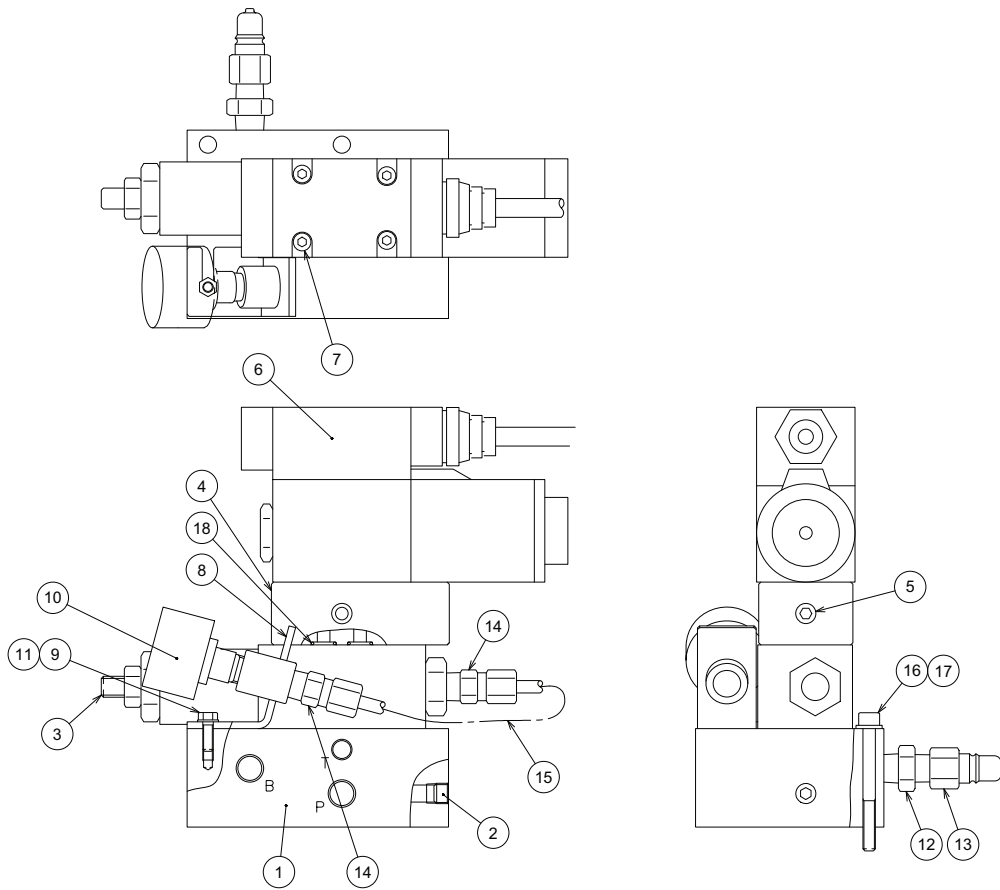

Unit No. 100

Head-end Positioning(3)

| Index | Code | Parts Name | Drawing No. | Type | Maker | Q'ty | Note |
|-------|----------|-------------------------------------|-------------|---------------|---------------|------|------|
| 1 | 10301755 | Sub Plate B | RB01471--- | | | 1 | |
| 2 | 10301572 | Plug for Piping | P580202011 | SPA01-000J | IHARA Science | 2 | |
| 3 | 10578877 | Hydraulic Control Valve | P543048001 | RDM-02-P35-20 | Nachi-Tohoku | 1 | |
| 4 | 10301756 | Sub Plate 2 | RB01472--- | | | 1 | |
| 5 | 10301572 | Plug for Piping | P580202011 | SPA01-000J | IHARA Science | 2 | |
| 6 | 10301623 | Hydraulic Directional Control Valve | RB0054071- | | | 1 | |
| 7 | 10378662 | Hex Socket Cap Screw | P330210055 | M5X120 | | 4 | |
| 8 | 10301757 | Stand | RB01474--- | | | 1 | |
| 9 | 10386623 | Bolt | P330010004 | M5X15 | | 1 | |
| 10 | 10301624 | Pressure Gauge | RB0054072- | | | 1 | |
| 11 | 10589273 | Washer | P336000080 | 5(Normal) | | 1 | |
| 12 | 10329329 | Nipple | P580020002 | 1/4 | JIS | 1 | |
| 13 | 10375464 | Quick Connect Joint | P589026080 | 2P-BSBM | NITTO KOHKI | 1 | |
| 14 | 10301573 | Bite Type Pipe Fitting | P585538015 | KC6-R1/4-B | IHARA Science | 2 | |
| 15 | 10301758 | Copper Pipe | RB01475--- | | | 1 | |
| 16 | 10329645 | Hex Socket Cap Screw | P330220018 | M6X60 | | 2 | |
| 17 | 10321922 | Washer | P336000005 | 6(Normal) | JIS | 2 | |
| 18 | 10314519 | O Ring | P590000007 | P9 | | 4 | |

Unit No. 101
Head-end Positioning(4) <Hydraulic Unit>

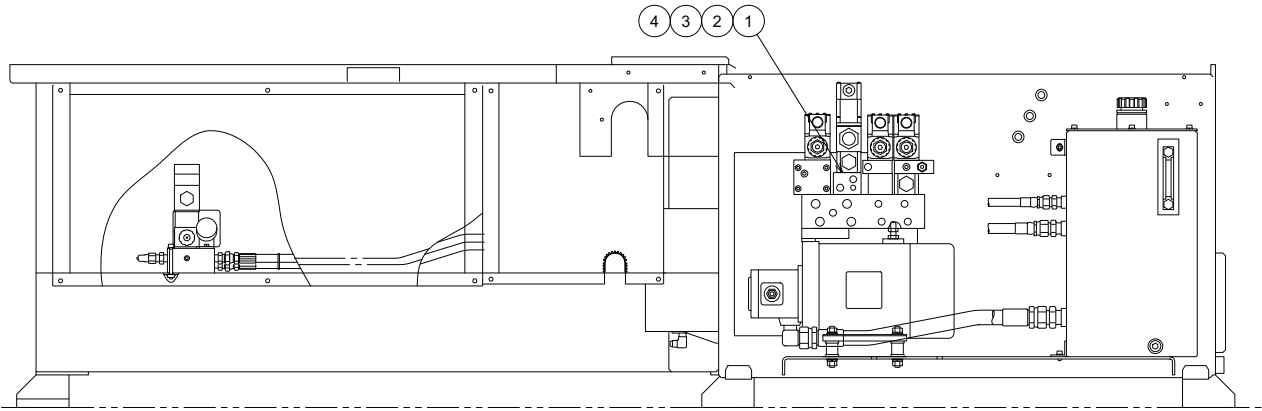

1278883--A
(1278882--B)

Unit No. 101

Head-end Positioning(4)

| Index | Code | Parts Name | Drawing No. | Type | Maker | Q'ty | Note |
|-------|----------|----------------------|-------------|------------|---------------|------|------|
| 1 | 10578874 | Sub Plate A | 1429543 A | | | 1 | |
| 2 | 10301572 | Plug for Piping | P580202011 | SPA01-000J | IHARA Science | 4 | |
| 3 | 10383541 | Hex Socket Cap Screw | P330210043 | M5X125 | MOURI | 4 | |
| 4 | 10314519 | O Ring | P590000007 | P9 | | 4 | |

Unit No. 102
Head-end Positioning(5)-1/2 <Piping>

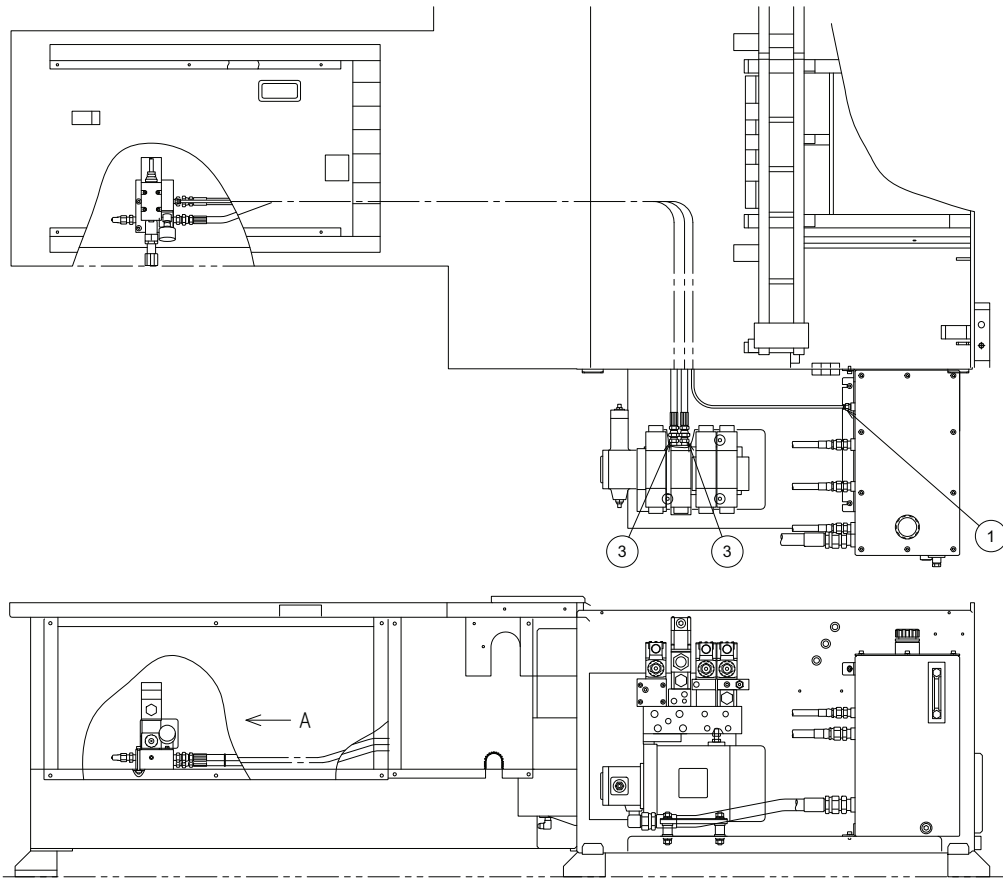

1278884--A
(1278882--B)

Unit No. 102
Head-end Positioning(5)-2/2 <Piping>

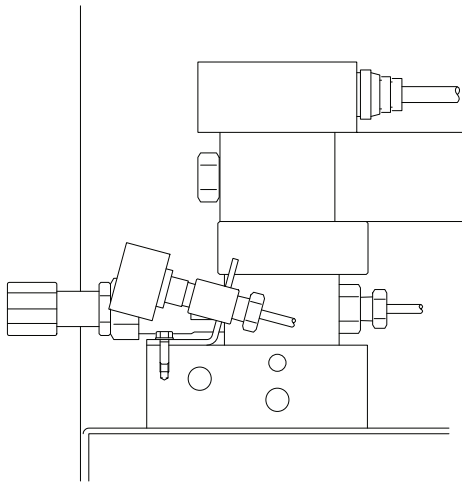

VIEW A

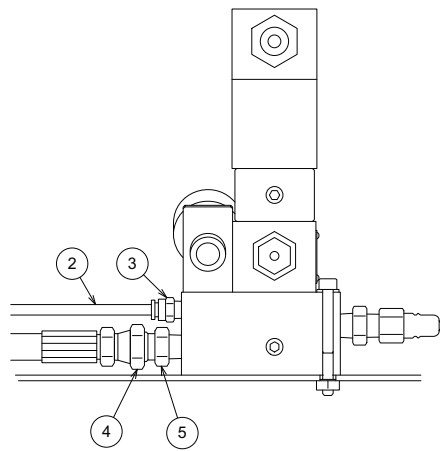

Unit No. 102

Head-end Positioning(5)

| Index | Code | Parts Name | Drawing No. | Type | Maker | Q'ty | Note |
|-------|----------|-------------------|-------------|----------------------|---------------------|------|------|
| 1 | 10419409 | One Touch Fitting | P586534003 | EC6-PT1/4 | NITTA MOORE | 1 | |
| 2 | 10301930 | Plastic Hose | P230222180 | N2-4-6X4(Black)-2.5M | NITTA MOORE | 1 | |
| 3 | 10419408 | One Touch Fitting | P586534002 | EC6-PT1/8 | NITTA MOORE | 1 | |
| 4 | 10301761 | Hydraulic Hose | RB01482--- | 3/8X2200L | | 2 | |
| 5 | 10301574 | Hose Adapter | P589222221 | 1013-PT1/4-PF3/8 | The Yokohama Rubber | 4 | |

Unit No. 103
Head-end Positioning(6) <Grooveless Vise Plate Specification>

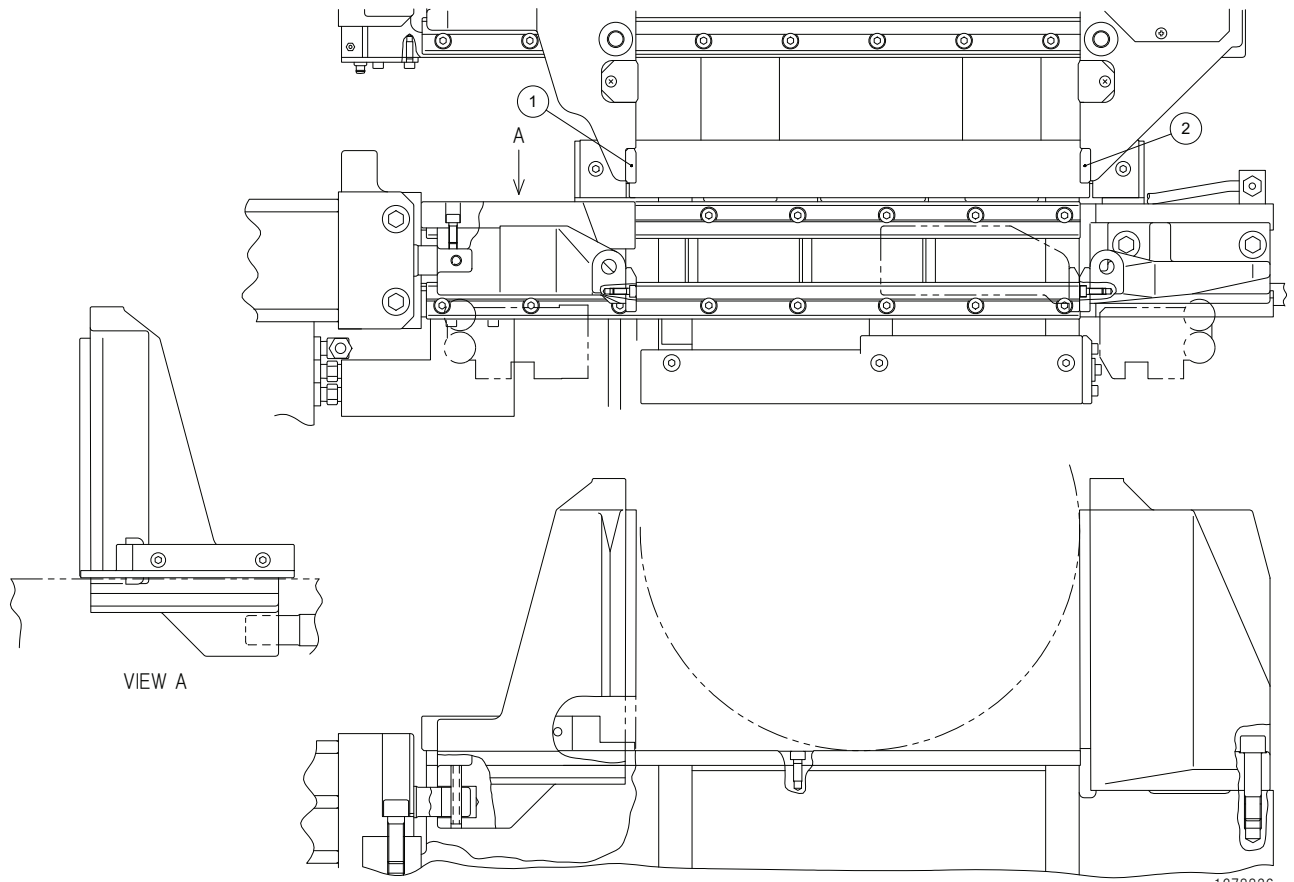

1278836---
(1278833--A)

Unit No. 103

Head-end Positioning(6)

| Index | Code | Parts Name | Drawing No. | Type | Maker | Q'ty | Note |
|-------|----------|-------------------|-------------|------|-------|------|------|
| 1 | 10378365 | Rear Vise Plate | 1238687 A | | | 3 | |
| 2 | 10419410 | Rear Vise Plate 2 | 1440418 | | | 1 | |

Unit No. 104
 Head-end Positioning(7)-1/2 <Electric>

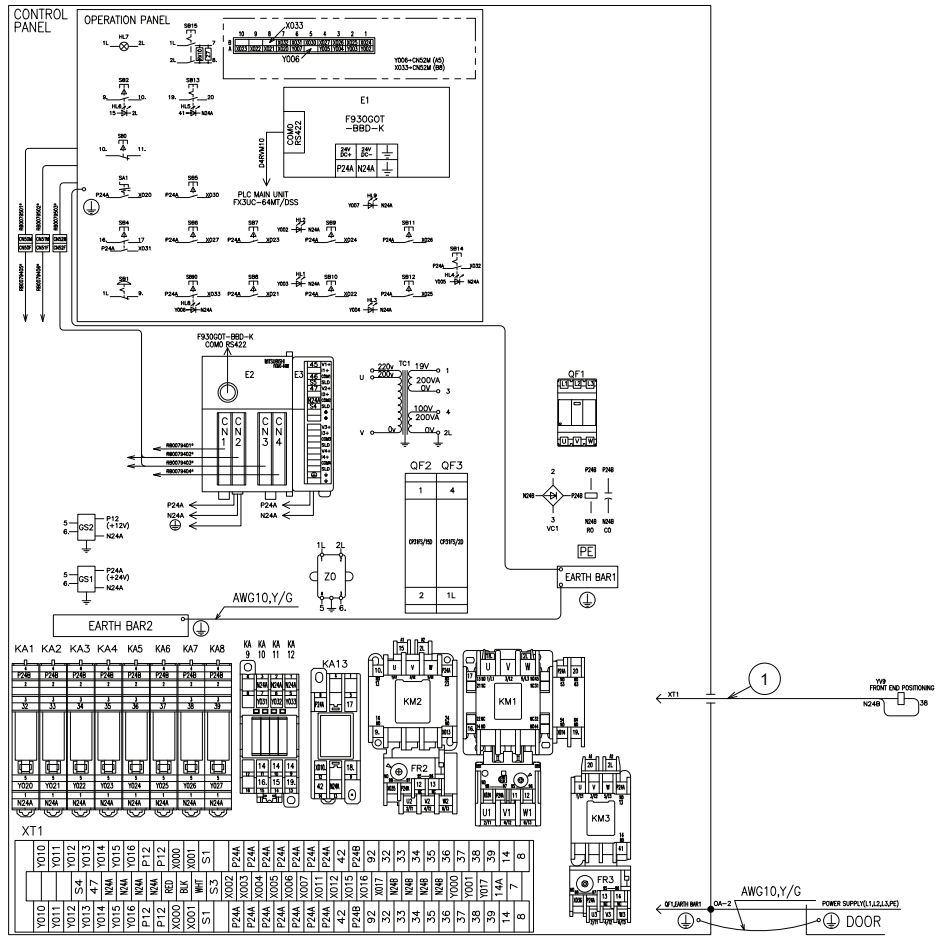

Unit No. 104
 Head-end Positioning(7)-2/2 <Electric>

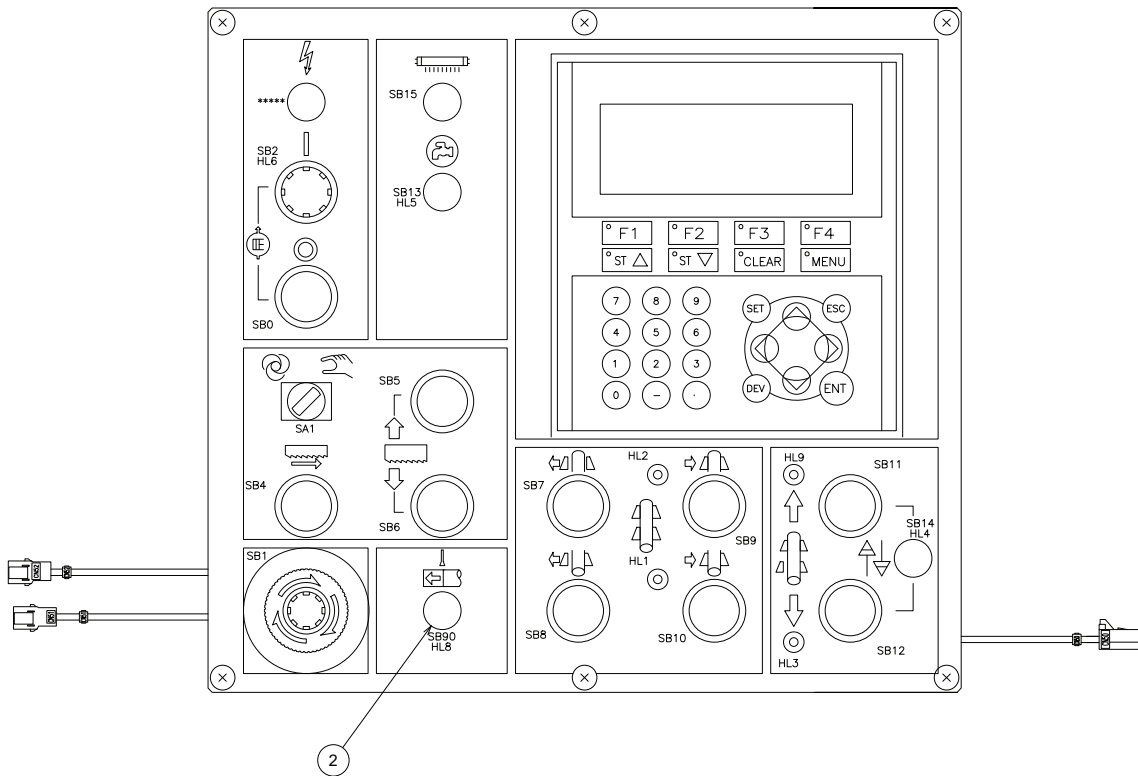

RB02410---
 (RB00795--B)

Unit No. 104

Head-end Positioning(7)

| Index | Code | Parts Name | Drawing No. | Type | Maker | Q'ty | Note |
|-------|----------|--------------------------------|-------------|------|-------|------|----------|
| 1 | 10301978 | Head-end Positioning SOL Cable | RB0153881A | | | 1 | |
| 2 | 10301768 | Head-end Positioning PB ASSY | RB01501--A | | | 1 | SB90,HL8 |

Unit No. 105
Head-end Positioning(8) <Cable>

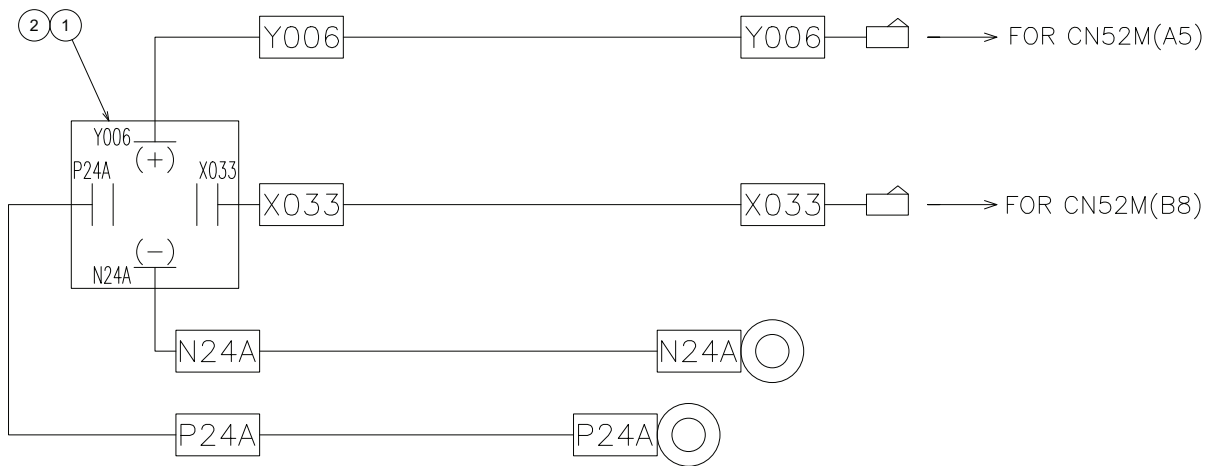

Unit No. 105

Head-end Positioning(8)

| Index | Code | Parts Name | Drawing No. | Type | Maker | Q'ty | Note |
|-------|----------|------------------------|-------------|-------------------|---------------|------|------|
| 1 | 10418729 | Illuminated Pushbutton | P822064028 | AH165-LW11E3/0182 | FUJI Electric | 1 | |
| 2 | 10579309 | Accessory for Switch | P821804061 | AHX676-B | FUJI Electric | 1 | |

Unit No. 106
Float Switch

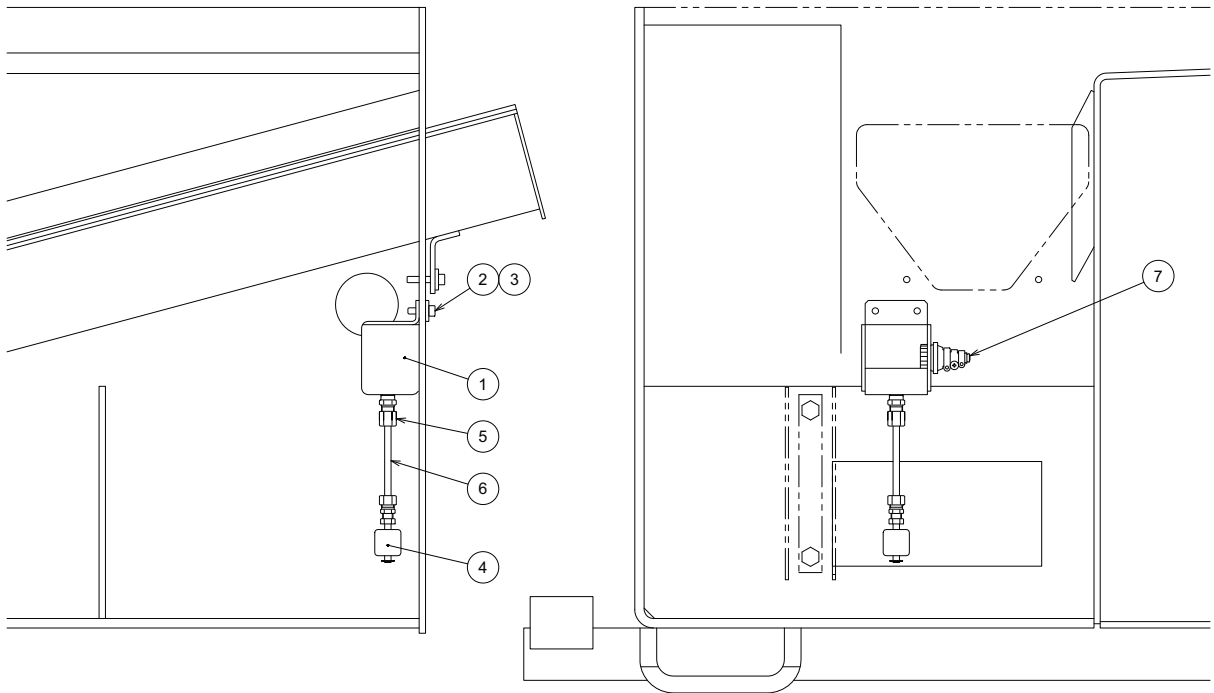

1230328
(1278796--A)

Unit No. 106

Float Switch

| Index | Code | Parts Name | Drawing No. | Type | Maker | Q'ty | Note |
|-------|----------|------------------------|-------------|------------|-----------------|------|------|
| 1 | 10301163 | Float Switch Bracket | 1230979 | | | 1 | |
| 2 | 10312832 | Hex Socket Cap Screw | P330220009 | M6X20 | JIS | 2 | |
| 3 | 10376462 | Washer | 1233546 A | | | 2 | |
| 4 | 10580526 | Level Switch | P829308004 | OLV-2B(2M) | NOHKEN Industry | 1 | |
| 5 | 10580527 | Bite Type Pipe Fitting | P585033016 | S-6X1/4 | BAN SS | 1 | |
| 6 | 10301164 | Pipe for Float Switch | 1230980 | | | 1 | |
| 7 | 10330110 | Accessory for Conduit | P866103001 | OA-1 | OHM Electric | 1 | |

Unit No. 107
Emergency Stop Button

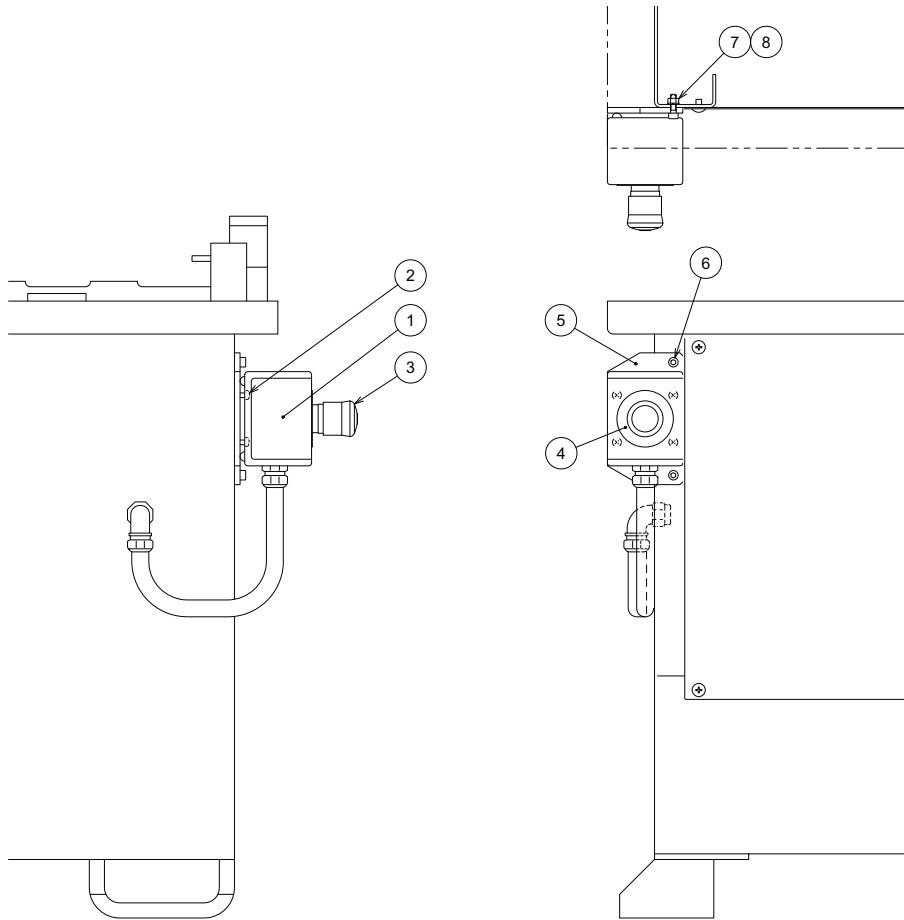

Unit No. 107

Emergency Stop Button

| Index | Code | Parts Name | Drawing No. | Type | Maker | Q'ty | Note |
|-------|----------|----------------------|-------------|------------|---------------|------|------|
| 1 | 10300202 | Accessory for Switch | P821806017 | KGNW111Y | IDEC | 1 | |
| 2 | 10322224 | Pan Head Screw | P334100039 | M5X10 | JIS | 4 | |
| 3 | 10300201 | Push Button Switch | P821088012 | M22-PV/K01 | MURA Electric | 1 | |
| 4 | 10300203 | Accessory for Switch | P821807007 | M22-XBK | MURA Electric | 1 | |
| 5 | 10301548 | Base Plate | RB02648--- | | | 1 | |
| 6 | 10312832 | Hex Socket Cap Screw | P330220009 | M6X20 | JIS | 2 | |
| 7 | 10310351 | Spring Washer | P336050005 | 6 | JIS | 2 | |
| 8 | 10589225 | Nut | P332000004 | M6 | JIS | 2 | |

Unit No. 108
Signal Tower-1/2

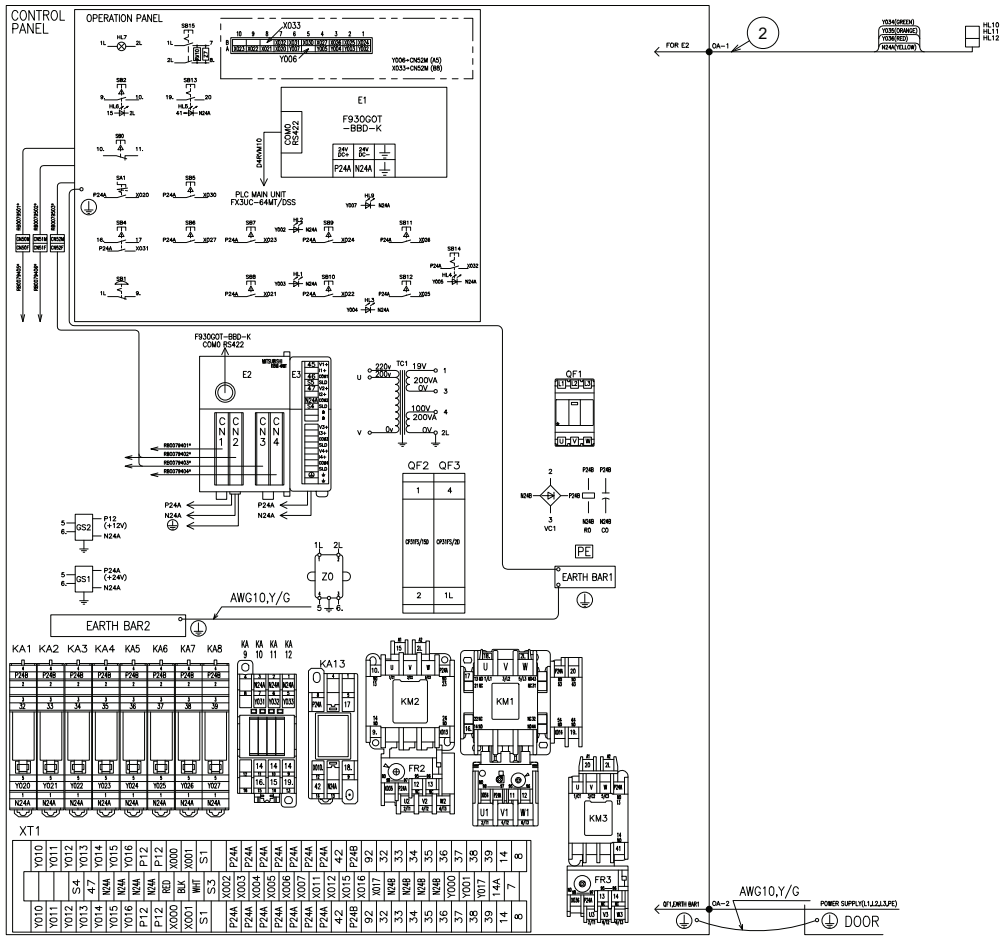

Unit No. 108
Signal Tower-2/2

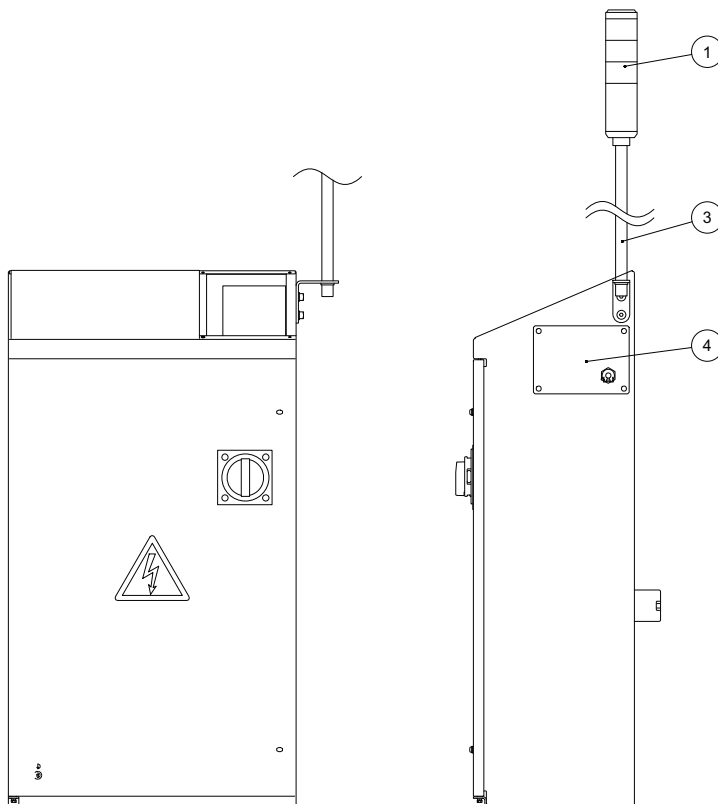

Unit No. 108

Signal Tower

| Index | Code | Parts Name | Drawing No. | Type | Maker | Q'ty | Note |
|-------|----------|---------------------------------|-------------|---------------|---------|------|------|
| 1 | 10579311 | Signal Light Unit | P642142046 | LME-302W-RYG | PATLITE | 1 | |
| 2 | 10301792 | Signal Light Cable Add Works | RB0152341- | | | 1 | |
| 3 | 10579313 | Accessory for Signal Light Unit | P642178006 | SZ-70L(640MM) | PATLITE | 1 | |
| 4 | 10300823 | Cover Add Works | RB0077501B | | | 1 | |

Unit No. 109
Option Accessory(1)

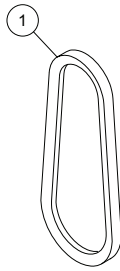

RB02495---

Unit No. 109

Option Accessory(1)

| Index | Code | Parts Name | Drawing No. | Type | Maker | Q'ty | Note |
|-------|----------|------------|-------------|------|-------|------|------|
| 1 | 10380583 | V-belt | P223000016 | M48 | | 1 | |

Unit No. 110
Option Accessory(2) <Tool Set>

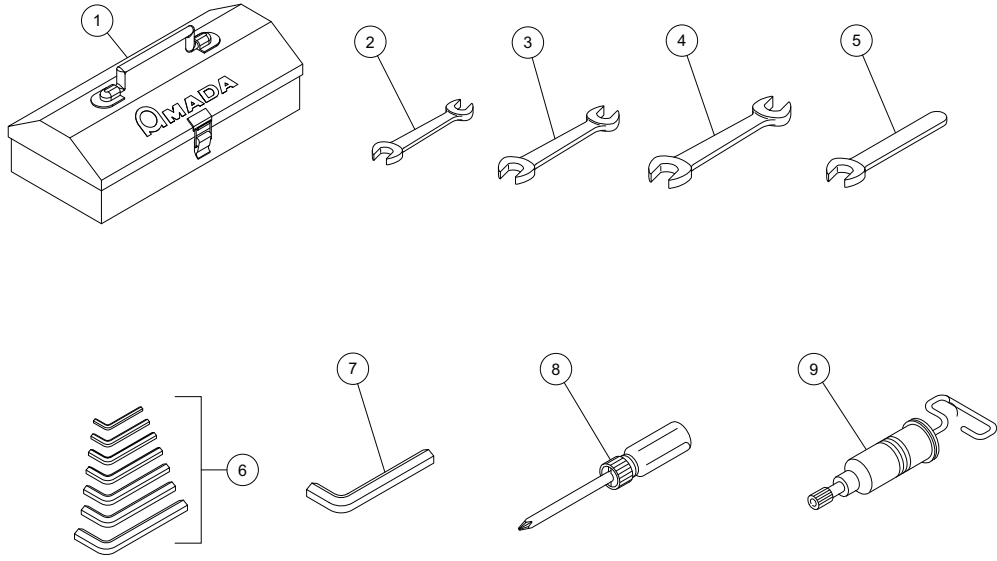

Unit No. 110

Option Accessory(2)

| Index | Code | Parts Name | Drawing No. | Type | Maker | Q'ty | Note |
|-------|----------|---------------------|-------------|------------------|--------|------|------|
| 1 | 10581225 | Tool Box | 7912021 | 350X150X65(TM-2) | | 1 | |
| 2 | 10345208 | Wrench | P351010013 | 13X17 | | 1 | |
| 3 | 10345209 | Wrench | P351010010 | 19X22 | | 1 | |
| 4 | 10345210 | Wrench | P351010003 | 24X27 | | 1 | |
| 5 | 10345211 | Single Ended Wrench | P351000022 | 14 | | 1 | |
| 6 | 10301287 | Bar Wrench Set | P351040002 | 2.5-3-4-5-6-8-10 | | 1 | |
| 7 | 10485309 | Socket Screw Key | P351030011 | 14 | JIS | 1 | |
| 8 | 10485310 | Screwdriver | P353000004 | H2(Normal) | JIS | 1 | |
| 9 | 10345225 | Grease Gun | P359308003 | KH-35 | YAMADA | 1 | |