



V2026NC

Vertical Semi-Automatic Hydraulic
Dual Miter Cutting Bandsaw

Instruction Manual

The Pinnacle of Cutting Performance
Cosen Mechatronics Co., Ltd.

FROM THE MANUFACTURER

Thank you for your purchase of COSEN's bandsaw machine and your trust in the COSEN brand.

We are excited to have you as our valued customer and look forward as much as you do to the accelerated productivity, long-lasting endurance and superb cost-effectiveness this machine is about to bring to you.

To ensure you are fully utilizing our machine and being advantaged in every possible way, please do take your time and read through this instruction manual.

Any comment or suggestion in making our service better, please do not hesitate to let us know. Thank you again!

NOTE:



- Read this instruction manual carefully to familiarize yourself with the installation, operation and maintenance of your COSEN bandsaw machine.
- Operate the machine following the procedures described in the manual to prevent personal injuries or machine damage.
- Keep this manual handy and refer to it whenever you are uncertain of how to perform any of the procedures.



- For technical support or parts purchase, please contact your nearest COSEN representative or our service center:

For Europe:
email: europe@cosensaws.com
phone: +31-77-7600280
fax: +31-77-7600288
web: www.cosensaws.eu

For US, Mexico, and Canada:
email: info@cosensaws.com
phone: +1-704-943-1030
toll free: +1-877-SAWING1
fax: +1-704-943-1031
web: www.cosensaws.com

For China:
email: service@cosensaws.cn
phone: +86-152-50127815
web: www.cosensaws.cn

For Taiwan and other countries:
email: info@cosen.com
phone: +886-3-5332143
fax: +886-3-5348324
web: www.cosen.com.tw

Instruction Manual:

V2026NC

Vertical Semi-Automatic Hydraulic Dual Miter Cutting Bandsaw
Ver.4 2017/07/03

© 2013 by COSEN MECHATRONICS CO., LTD.

No part of this publication may be photocopied or otherwise reproduced without the prior written permission of COSEN.

Printed in Taiwan

Safety rules



- Make sure your work area is cleared of uninvited people and obstacles every time before you start operating the machine.



- Never step or stand on the roller table. Your foot may slip or trip on the rollers and you will fall.



- Never wear gloves or loose clothing when operating the machine. It may lead to serious injury if they are caught in the running machine. Wrap or cover long hair.

- Never touch the running saw blade with gloves or not. It is dangerous if your hands, clothing or gloves are caught by the running blade.



- Make sure any use of fire is prohibited in the shop and install a fire extinguisher or other fire control device near the machine when cutting titanium, magnesium, or any other material that produces flammable chips. Never leave the machine unattended when cutting flammable materials.



- Use a water-soluble cutting fluid on this machine. Oil-based cutting fluids may emit smoke or catch fire, depending on how they are used.



- Never cut carbon or any other material that may produce and disperse explosive dust. It is possible that sparks from motors and other machine parts will ignite and explode the air-borne dust.

Safety rules



- Never adjust the wire brush or remove chips while the saw blade is still running. It is extremely dangerous if hands or clothing are caught by the running blade.
- Stop the saw blade before you clean the machine. It is dangerous if hands or clothing are caught by the running blade.
- Never start the saw blade unless the workpiece has been clamped firmly. If the workpiece is not securely clamped, it will be forced out of the vise during cutting.



- Take preventive measures when cutting thin or short pieces from the work to keep them from falling. It is dangerous if the cut pieces fall.
- Use roller tables at the front and rear sides of the machine when cutting long work. It is dangerous if the work piece falls off the machine.



- Turn off the shop circuit breaker switch before performing maintenance on the machine. Post a sign indicating the machine is under maintenance.

Table of Contents

Section 1 – Safety Information	1-1
Safety Instructions	1-1
Safeguard Devices	1-3
Emergency Stop	1-4
<i>Illustration: Emergency Stop</i>	1-5
Safety Labels	1-6
<i>Illustration: Safety Labels</i>	1-7
Hearing Protection	1-8
CE Compliance	1-8
Risk Assessment	1-8
Section 2 – General Information	2-1
Specification	2-2
Machine Parts Identification	2-3
Floor Plan	2-4
Section 3 – Moving & Installation	3-1
Location & Environment	3-1
Unpacking & Inspecting	3-2
Lifting	3-3
<i>Illustration: Lifting Points</i>	3-5
Removing Shipping Bracket	3-6
Cleaning	3-6
Installing	3-6
Supplying Hydraulic Oil	3-6
Supplying Coolant	3-7
Connecting Electric Power	3-7
Leveling	3-8
Anchoring	3-9
Installing Roller Table (Optional)	3-9
Installing Fire Control Device.....	3-9
Relocating	3-9
Section 4 – Operating Instructions	4-1
Safety Precautions	4-2
Before Operating	4-3
Control Panel	4-4
Control Panel	4-4

Table of Contents

Control Buttons	4-4
Cutting Pressure, Vise Pressure, and Feeding Speed Control Panel	4-7
Human-Machine-Interface (HMI) Touch Screen	4-8
Standard Accessories	4-16
Optional Accessories	4-18
Unrolling & Installing the Blade	4-19
Adjusting Wire Brush	4-20
Placing Workpiece onto Workbed	4-21
Positioning Workpiece for Cutting	4-21
Adjusting Coolant Flow	4-21
Adjusting Saw Bow Inclining Angle	4-22
Adjusting Blade Speed	4-22
Breaking-In the Blade	4-23
Test -Running the Machine	4-23
Cutting Operation	4-23
Terminating a Cutting Operation	4-24
Section 5 – Bandsaw Cutting: A Practical Guide	5-1
Introduction	5-2
Saw Blade Selection	5-2
WISE LOADING	5-3
BladeBreak -In	5-4
Section 6 – Maintenance & Service	6-1
Introduction	6-1
Basic Maintenance	6-1
Maintenance Schedule	6-1
Before Beginning a Day’s Work	6-2
After Ending a Day’s Work	6-2
Every Month	6-2
Every Three Months	6-2
Every Six Months	6-3
Storage Conditions	6-3
Terminating the Use of Machine	6-3
Oil Recommendation for Maintenance	6-4
Section 7 – Troubleshooting	7-1
Introduction	7-1
Precautions	7-2

Table of Contents

General Troubles & Solutions	7-2
Minor Troubles & Solutions	7-3
Motor Troubles & Solutions	7-3
Blade Troubles & Solutions	7-4
Sawing Problems & Solutions	7-5
Re-Adjusting the Roller Table	7-12
Section 8 – Spare Parts Recommendations	8-1
Spare Parts Recommendations	8-1
Part List	8-2
Section 9 – Warranty	9-1
Warranty	9-1
Appendix	
Declaration of Conformity	
Electrical System	
Hydraulic System	

SAFETY INFORMATION

SAFETY INSTRUCTIONS

SAFEGUARD DEVICES

EMERGENCY STOP

SAFETY LABELS

HEARING PROTECTION

CE COMPLIANCE

RISK ASSESSMENT

Safety is a combination of a well-designed machine, operator's knowledge about the machine and alertness at all times. COSEN's band machine has incorporated many safety measures during the design process and used protective devices to prevent personal injuries and potential risks. Warning labels also serve as a reminder to the operator.

Throughout this manual, you will also see various safety-related symbols indicating important information that you should take note of prior to use of the machine or part of its functions. These important safety instructions do not cover all possible situations that might occur. It is your responsibility to take caution and follow procedures stated in this manual when installing, maintaining and operating your machine. Cosen will not be liable for damages resulting from improper use.

SAFETY INSTRUCTIONS

What the icons and signs in this user manual mean:



This icon marks **DANGER**; hazards or unsafe practices that may result in **severe personal injury or death**.



This icon marks **WARNING**; hazards or unsafe practices that may result in **personal injury or damage to the machine**.



This icon marks **CAUTION**; information that should be read before use to prevent **damage to the machine**.



Supplementary information to the procedures described in this manual.



Call your local agent or our service center for help.



This manual has important safety information. Read through it carefully before operating this machine to prevent personal injury or machine damage. Learn the operation, limitation and the specific potential hazards peculiar to this band saw.



Do not operate this machine unless it is completely assembled.



Make sure the power switch is off before plugging in power cord.



Disconnect the power cord before making adjustment, maintenance or blade changes.



Keep all guards and shields in place before installing or starting up the machine.



Wear proper apparel during operation and when servicing the machine.



Keep unauthorized personnel away.



Do not reach over or stand on any part of the machine.



Never hold the material by hand for cutting. Always use the vise and make sure the material is clamped securely before cutting.



It is dangerous to operate the machine when the floor is slippery. Keep the floor clean and dry. Check for ice, moisture, or grease before entering.



Do not use the machine to cut explosive material or high pressure vessels as it will generate great amount of heat during the sawing process and may ignite an explosion.



Keep the work environment safe. Do not use band saw in a damp or wet location.



Never operate while under the influence of drugs, alcohol or medication.



All users must read it before performing any activity on the machine, such as replacing the saw band or doing regular maintenance.



Some personal protective equipment is required for the safe use of the machine, e.g. protection goggles.



Keep blade protection cover and wheel covers in place and in working order.



Use recommended accessories. Improper accessories may be hazardous.



Keep your work area well illuminated at minimum 500 lumen.



Keep your work area clean. Cluttered and slippery floors invite accidents.



Remove adjusting keys, wrenches or any loose parts or items from the machine before turning on power.



Check for damaged parts. Before continuing using the machine, the damaged part should be checked and replaced.



Moving parts should be kept in proper alignment and connection with the machine. Check for breakage, mounting and any other conditions that may affect its operation. Any damaged part or guard should be properly repaired or replaced.



When a workpiece is too long or heavy, make sure it is supported with a roller table (recommended).



Always remember to switch off the machine when the work is completed.



Use a sharp saw blade and keep the machine in its best and safest performance by following a periodical maintenance schedule.



Do not force the band saw beyond its intended use. It is safer to operate with the cutting rate for which it was designed.

SAFEGUARD DEVICES

The safeguard devices incorporated in this machine include the following two main parts:

1. Protection covers & guards
2. Safety-related switches

Protection Covers & Guards

1. Idle wheel housing cover
2. Drive wheel housing cover
3. Gear reducer cover
4. Wire brush belt cover
5. Blade guard cover (left & right)
6. Chip conveyor cover (CE model only)



The protection devices should always be mounted on the machine whenever the machine is running.



Do not remove any of these safeguard devices under any circumstances except when servicing the machine. Even skilled service technicians should still take cautions when performing repairs or service on the machine with any of these protectors removed. It is the responsibility of the user to make sure all these elements are not lost and damaged.



Take note of the following main moving parts on the machine prior to and during machine operation:

- Saw bow assembly
- Drive and idle wheels
- Blade guide arm
- Saw blade guide rollers
- Quick approach device
- Wire brush
- Chip conveyor (optional)
- Workpiece clamping vises
- Shuttle vises and workbed rollers
- Top clamps (optional)
- Gear reducer

Safety Related Switches

To protect the operator, the following safety related switches on the machine are actuated when the machine is in operation.

Wheel motion detector	This is a proximity sensor used to detect the motion of the drive wheel. Once the saw blade is broken or as soon as it starts slipping, the sensor will detect and stop the drive wheel and the machine.
Power switch	Located on the cover of electrical cabinet, the power switch controls the main power of the machine.
Emergency stop button	Located on the control panel, the button when pressed will stop the machine completely.
Vise clamp switch	This switch assures firm clamping of the workpiece. If the workpiece is not clamped properly, the saw blade is not allowed to run.
Wheel cover interlock switches (CE model only)	Located on the two wheel housings, these switches are used to assure that the machine will stop whenever the wheel covers are open. This device is to protect users from being cut by the running saw blades.

Among all these safety switches, some of them are used to protect the users and some of them are used to prevent damage to saw blades, the workpiece and the machine itself, etc. We have taken every precaution to prevent injury or damage and to provide safe and economical operation of the machine.

EMERGENCY STOP

Designed to be easily accessible, the emergency stop button is located on the left bottom corner on the control panel and is made in red color and rubber material. For CE models, supplementary emergency stop button may be available at other area(s) of the machine depending on machine type. Please refer to *Illustration: Emergency Stop*.

When you press the button, the machine will immediately come to a full stop to avoid injury or damage when an accident occurs. The button will be locked when you press it. To unlock it, pull it upward.

You should press it immediately without any hesitation when observing:

- An emergency situation that would cause any injury or damage
- An abnormal situation or problem such as fire, smoke, abnormal noise and etc.

Illustration: Emergency Stop

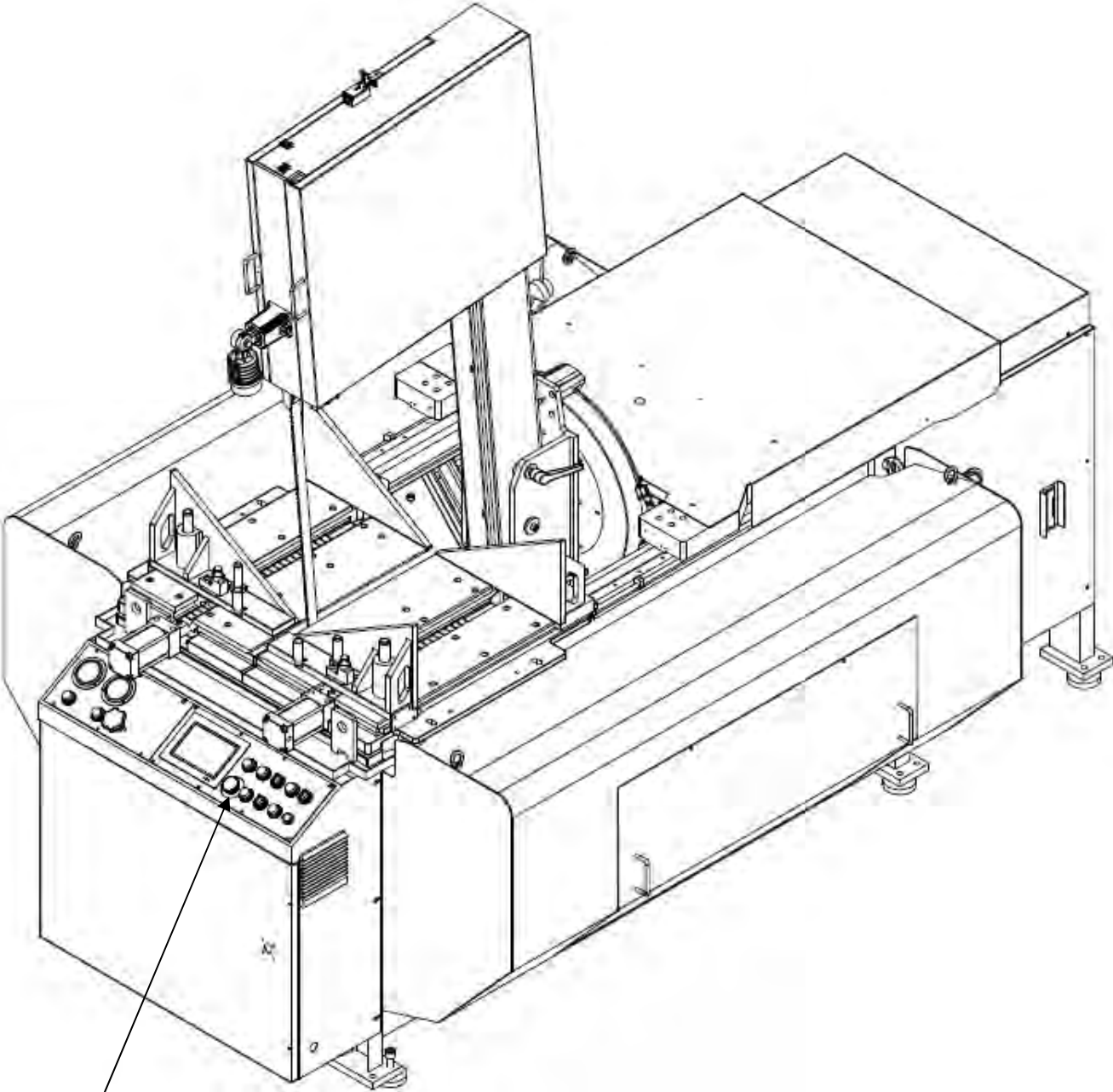

Emergency Stop

SAFETY LABELS

Please read through and understand them before operating the machine. Refer to *Illustration: Safety Labels*.

Label	Meaning	Label	Meaning
	Impact Hazard WEAR SAFETY SHOES. Do not approach dropping area during operation.		Read Operator's Manual This manual has important safety information. Read through it carefully before operating this machine to prevent personal injury or machine damage.
	Keep Unauthorized Personnel Away		Do not step. Do not stand on the machine or on the accessories!
	DANGER: Running Blade Blade runs through this area. Keep your hands away from a running blade to avoid severe injury. The arrow indicates direction of the blade.		Cutting Hazard KEEP COVER CLOSED / KEEP HAND OFF while the blade is running. Turn power off before opening cover. Failure to follow the warning can result in severe injury.
	Hazardous Voltage TURN POWER OFF before servicing. Failure to following the warning can result in severe injury.		Burn Hazard/Hot Surface
	Hand Crush/Force from Above		Crush hazard by vise
	Loose Hand Hazard KEEP HAND OFF. Do not touch chip conveyor. Failure to follow the warning can result in severe injury.		Pinch Point/Hand Entanglement

Illustration: Safety Labels

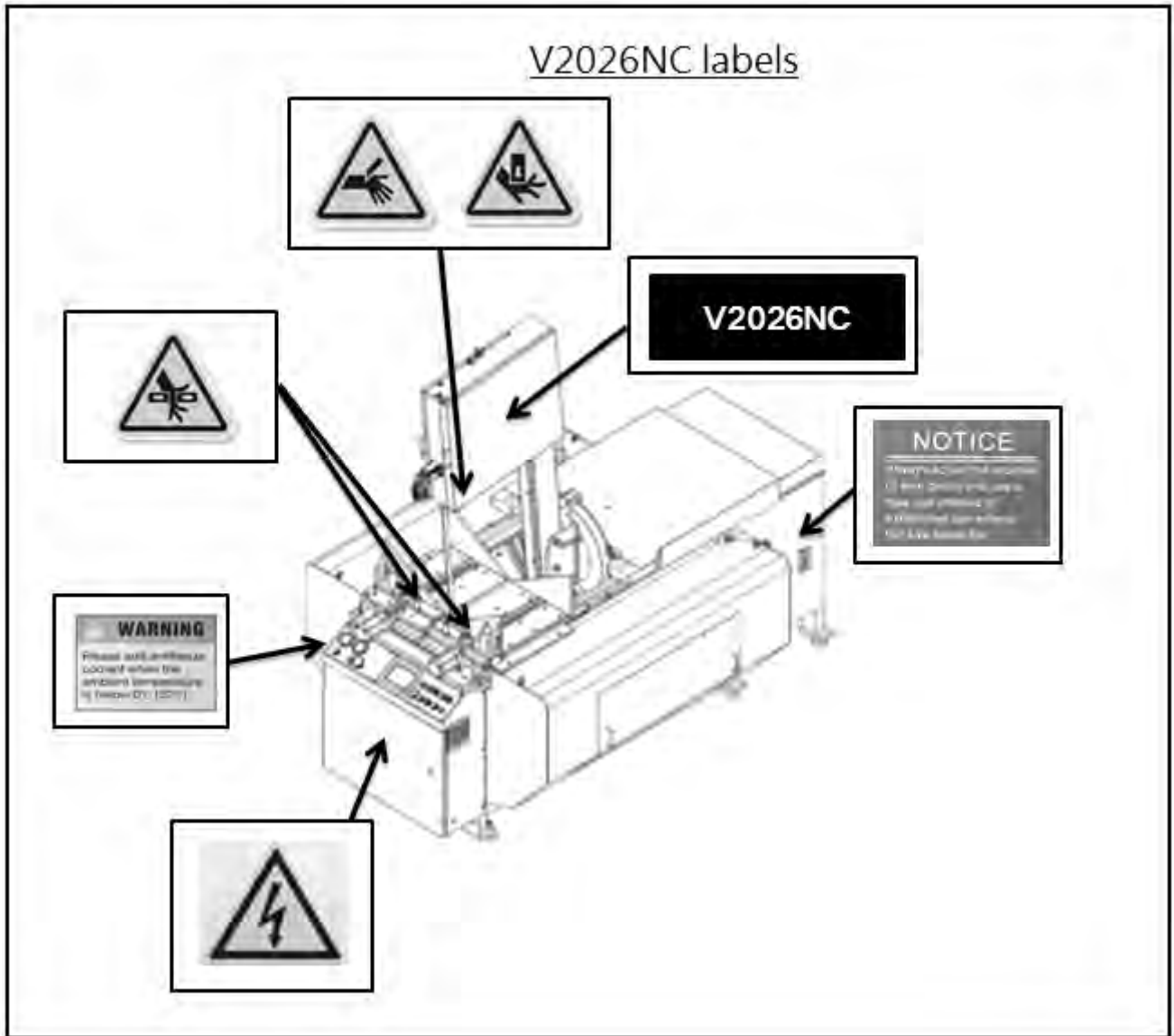

HEARING PROTECTION



Always use ear protection!

When your machine is running, noise generated by the machine may come from the following:

- Saw blade during cutting or material feed mechanism
- Wire brush unit
- Chip conveyor unit
- Speed reducer
- Hydraulic motor/pump
- Belt transmissions variable speed motors
- Blade motor
- Coolant pump
- Drive wheel
- Parts not assembled tightly causing mechanical vibration

Our products pass noise testing less than 78 dBA. Noise level vary according to working conditions and we recommend ear plugs or other hearing protection at all time. If your machine produces an undesirable noise while it is running, you should:

1. Make sure all maintenance tasks have been performed following the prescribed maintenance schedule (Refer to Section 8).
2. If maintenance does not seem to solve the problem, follow the troubleshooting procedures under Section 9.

CE COMPLIANCE

Cosen's CE model is designed to satisfy regulations of the Council Directive on the approximation of the laws of the Member States relating to machinery (2006/42/EC) - Annex I Essential health and safety requirements relating to the design and construction of machinery.

RISK ASSESSMENT

Risk assessment generally takes account of intended use and foreseeable misuse, including process control and maintenance requirements. We made every effort to avoid any personal injury or equipment damage during the machine design stage. However, the operator (or other people) still needs to take precautions when handling any part of the machine that is unfamiliar and anywhere on the machine that has potential hazards (e.g. the electrical control box).

GENERAL INFORMATION

SPECIFICATION

MACHINE PARTS IDENTIFICATION

FLOOR PLAN

This band saw machine is designed by Cosen's R&D engineers to provide you the following features and advantages:

Safety

- This machine is designed to fully protect the operator from its moving parts during cutting operation.
- The machine and each component has passed strict testing (Council Directive on the approximation of the laws of the Member States relating to Machinery).
- The machine will shut off automatically when the saw blade is broken, protecting both the operator and the machine.

Convenience & High-Performance

- The machine is designed in the way that the operation and adjustment can be easily performed.
- The machine will stop automatically when out of stock.
- Dual valve system is designed to achieve optimal cutting performance with the simple setting of feed rate and perspective cutting pressure for different material.

Durability

- The intended life-span of the machine is counted based on regular daily operation. It is calculated with the life expectancy of 10 years under normal operating condition and exact attention to the maintenance schedule.

8 hours × 5 days × 52 weeks × 10 years = 20,800 hours

SPECIFICATION

Model		V2026NC	
Machine Type		Vertical Semi-Automatic Hydraulic Dual Miter Cutting Bandsaw	
Miter Degree		60° left ~ 60° right	
		0° Blade Cant (Horizontal x Vertical)	5° Blade Cant (Horizontal x Vertical)
Capacity	90°	510 x 720 mm (20" x 28.3")	510 x 660 mm (20" x 26.0")
	45° Left	510 x 495 mm (20" x 19.5")	510 x 455 mm (20" x 17.9")
	60° Left	510 x 330 mm (20" x 13.0")	510 x 305 mm (20" x 12.0")
	45° Right (Optional)	510 x 465 mm (20" x 18.3")	510 x 420 mm (20" x 16.5")
	60° Right (Optional)	510 x 285 mm (20" x 11.2")	510 x 250 mm (20" x 9.8")
Max. Vise Opening		510 mm (20")	
Top clamp capacity (H x W)		475 x 475 mm (18.7" x 18.7")	
Saw Blade	Speed	20 ~ 80 m/min (66 ~ 264 ft/min)	
	Size (L x W x T)	5,230 x 34 x 1.1 mm (205.9" x 1.3" x 0.043")	
	Tension	Hydraulically controlled	
	Guide	Interchangeable tungsten carbide	
	Cleaning	Steel wire brush	
Motor Output	Saw Blade	7.5 HP (5.6 kW)	
	Hydraulic	1 HP (0.75 kW)	
	Coolant Pump	1/4 HP (0.185 kW)	
Tank Capacity	Hydraulic	85 L (22.1 gal)	
	Coolant	130 L (34 gal)	
Workbed Height		1,045mm (41.1")	
Weight	Net	2,050 kg (4,519 lb)	
	Gross	2,180 kg (4,806 lb)	
Floor Space (L x W x H)		2,861 x 2,675.5 x 2,536.6 mm (112.6" x 105.3" x 99.9")	
Operating Environment	Temperature	5~40°C (41~104°F)	
	Humidity	30%~95% (without condensation)	

MACHINE PARTS IDENTIFICATION

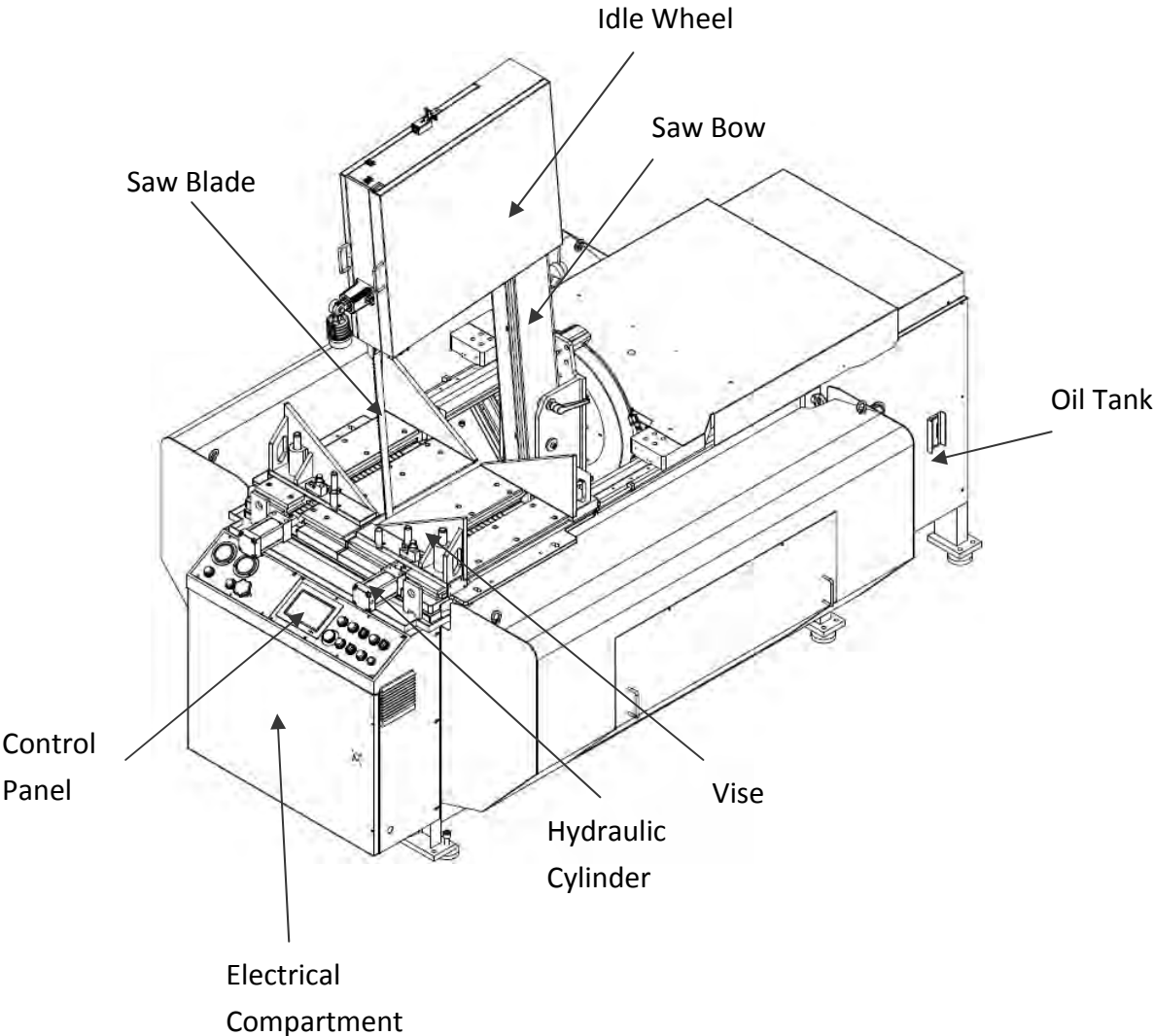

FLOOR PLAN

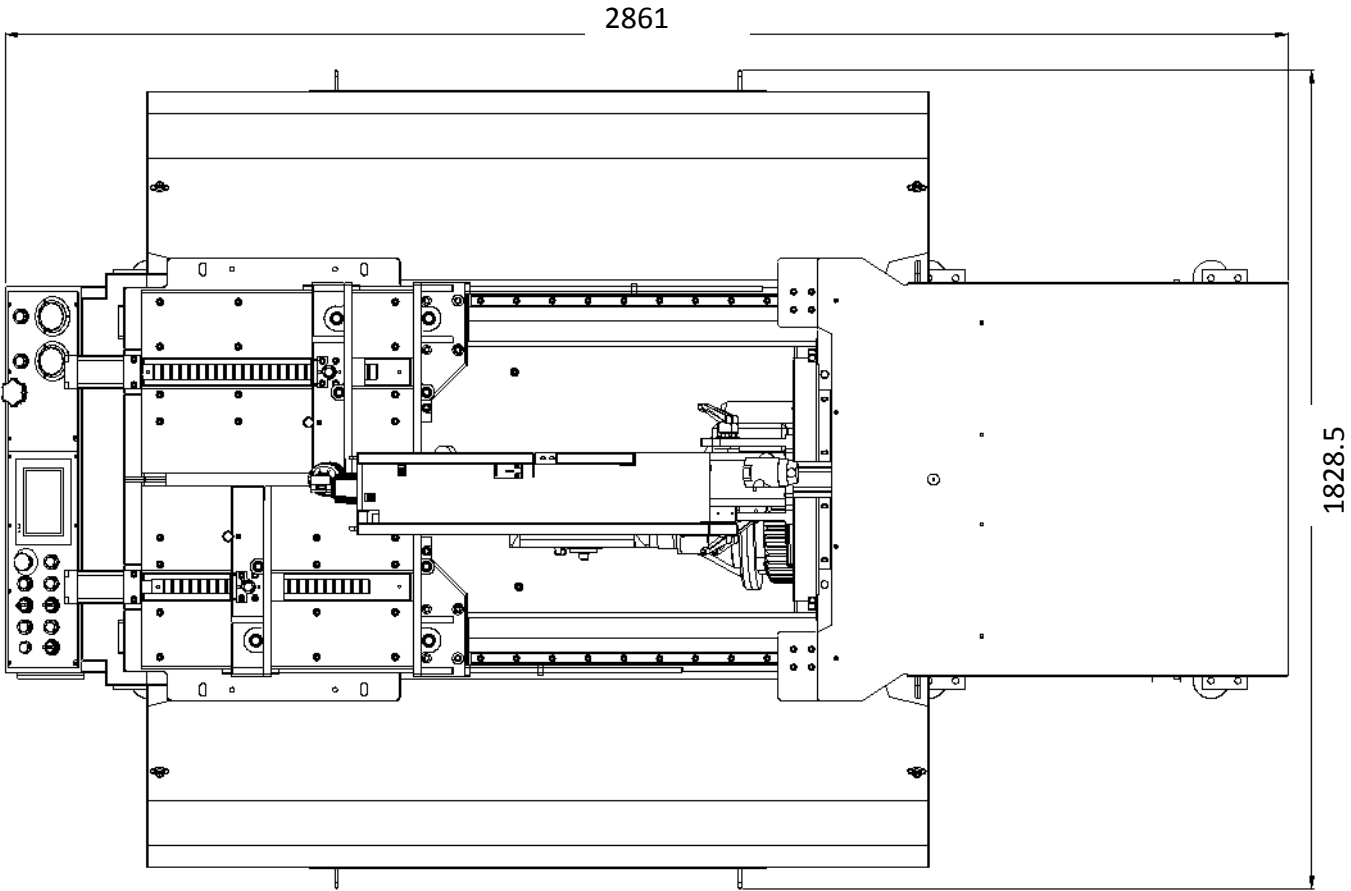

Machine top view

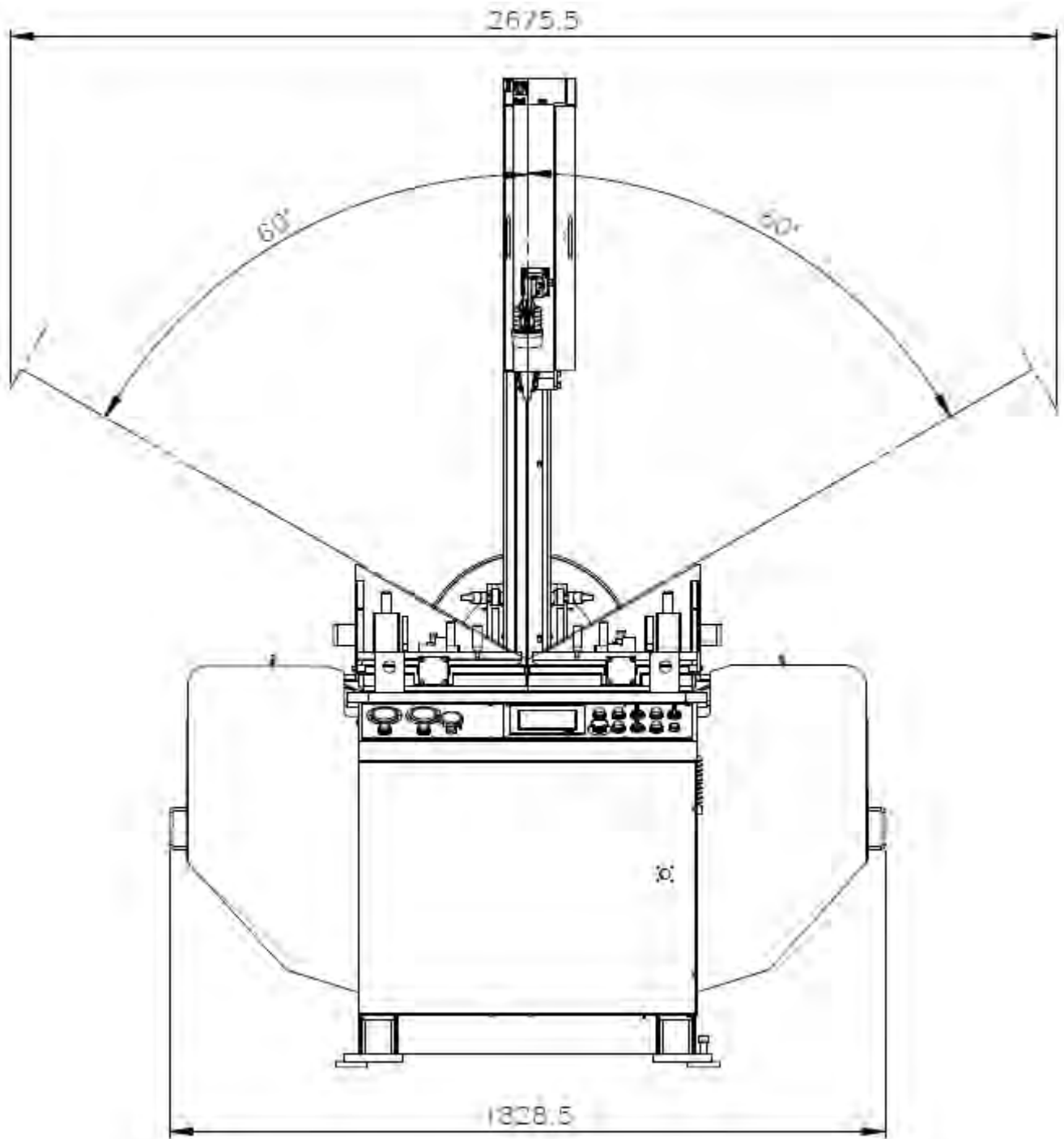

Machine front view

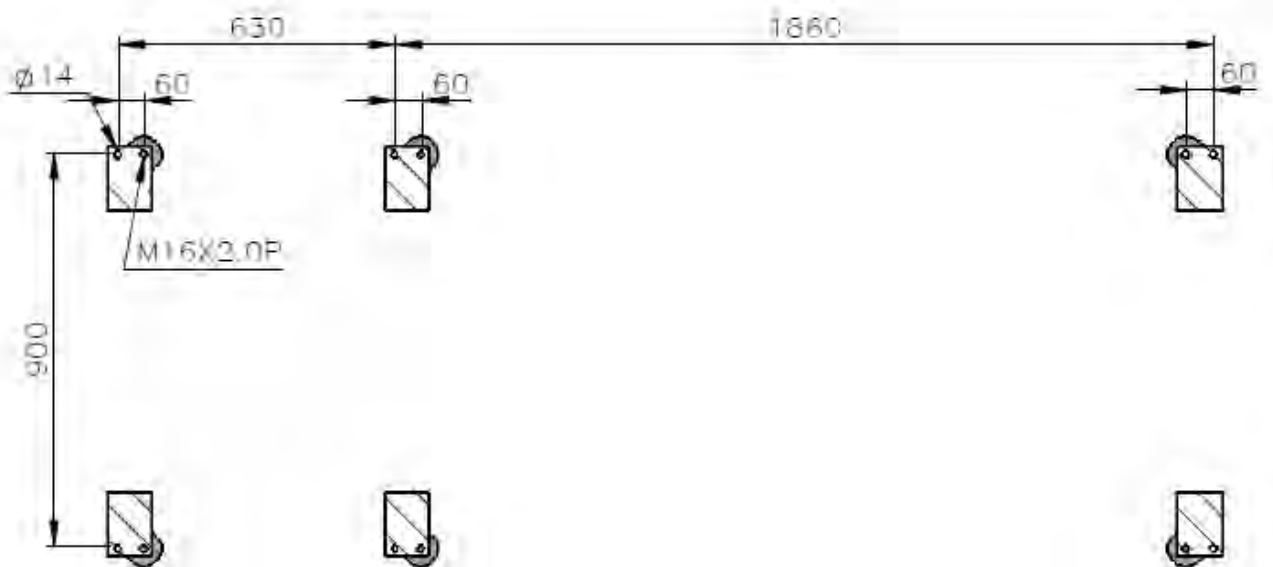
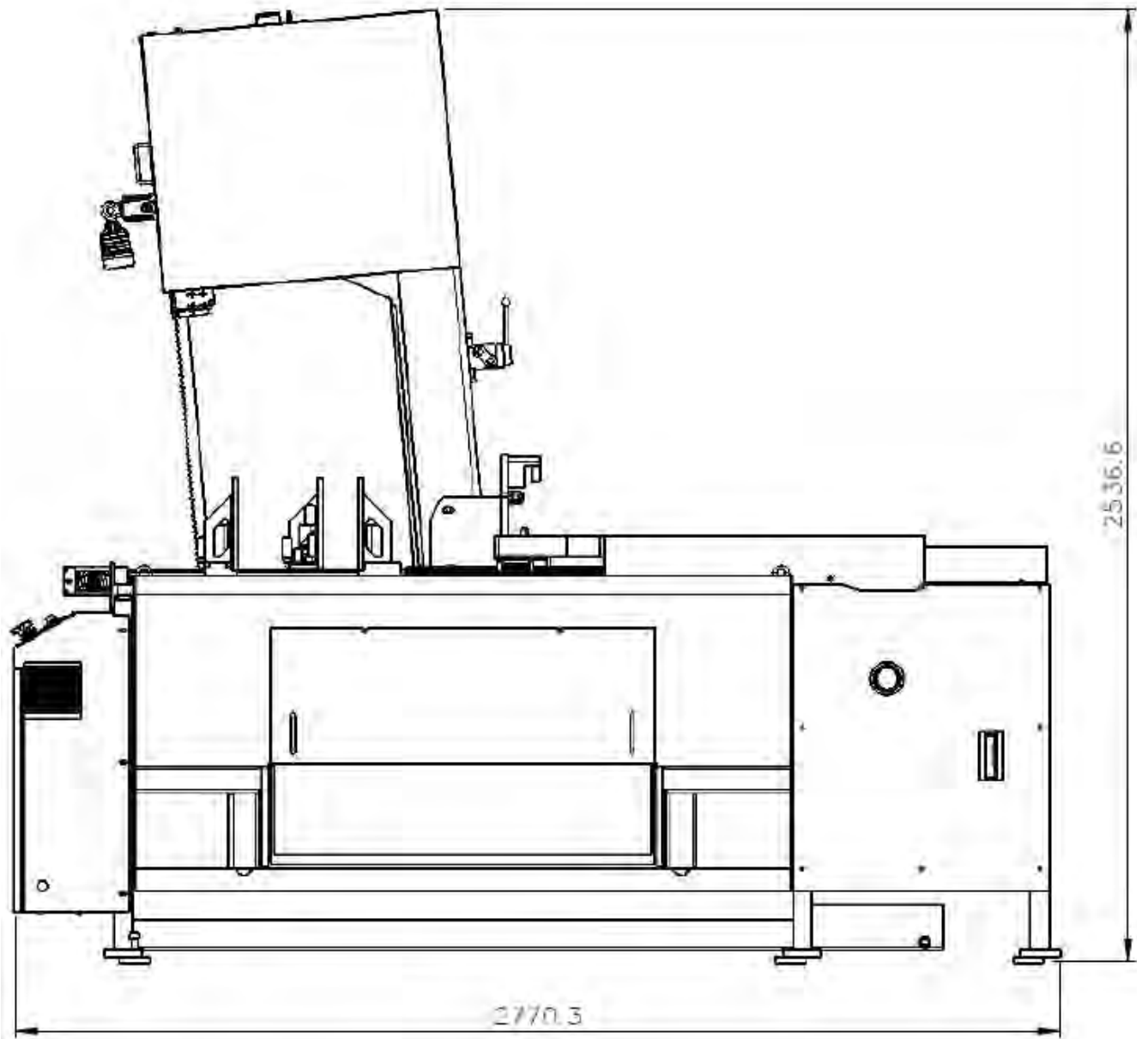

Machine right view

MOVING & INSTALLATION

LOCATION & ENVIRONMENT

UNPACKING & INSPECTING

LIFTING

REMOVING SHIPPING BRACKET

CLEANING

INSTALLING

RELOCATING

LOCATION & ENVIRONMENT

For your safety, please read all information regarding installation before proceeding. Install your machine in a place satisfying all of the following conditions:

Space:

- Leave enough free space around the machine for loading work and unloading cut-off pieces as well as for maintenance and inspection. Refer to *Section 2 Specification* for machine dimensions and floor space.

Environment:

- Well lighted (500 lumen at minimum).
- Floor kept dry at all times in order to prevent operators from slipping.
- Away from direct exposure to the sunlight
- Room temperature between 5°C to 40°C.
- Humidity level kept at 30%~95%“(without condensation) to avoid dew on electric installation and machine.
- Away from vibration of other machines
- Away from powders or dusts emitted from other machines
- Avoid uneven ground. Choose a solid level concrete floor which can sustain weight of both machine and material weight.
- Limit the operation area of the machine to staff only.

UNPACKING & INSPECTING

- Unpack your machine carefully to avoid damage to machine parts or surfaces.
- Upon arrival of your new band saw, please confirm that your machine is the correct model and it comes in the same specification you ordered by checking the model plate on the machine base.
- It is also imperative that a thorough inspection be undertaken to check for any damage that could have occurred during shipping. Pay special attention to machine surface, equipments furnished and the electrical and hydraulic systems for damaged cords, hoses and fluid leaks.
- In the event of damage caused during shipping, please contact your dealer and consult about filing a damage claim with the carrier.
- Your machine comes in with a set of tools for you to maintain the machine. The accessories furnished are as follows:

1.	Tool box	1 pc
2.	Grease gun	1 pc
3.	Screwdriver (+, -)	2 pcs
4.	Open-ended spanner	3 pcs
5.	Hexagon wrench	1 set
6.	Chip spade (only for manual models)	1 pc
7.	Operation manual	1 pc



Should you find any missing accessories, please contact your local agent immediately.

LIFTING

When moving the machine, we strongly suggest you choose any one of the methods described below to move your machine.

1. Use a crane

Move the machine to its location by using a crane and a wire rope sling that can fully withstand the weight of the machine (refer to machine specification under Section 2 *Specification*).

- Machine lifting is likely to damage the machine if not performed properly.



Warning: You must have a qualified crane operator to perform the job.

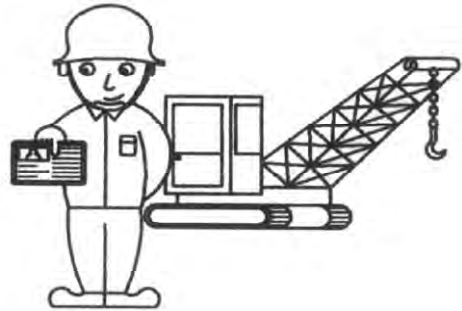

- You must use tools and equipment with the proper tensile strength and use proper method when moving your machine.
- Apply the wire rope sling to the lifting hooks on the four ends of the machine. Refer to *Illustration: Lifting Points* for exact locations.
- Slowly lift the machine. Be sure to protect the machine from impact or shock during this procedure. Also watch out your own fingers and feet to avoid injuries.
- Keep the machine well balanced during lifting process and make sure the wire rope does not interfere with the saw frame.
- When you work together with more than two people, it is best to keep constant verbal communication with each other.

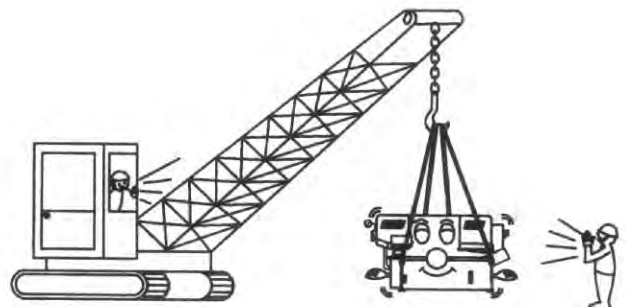
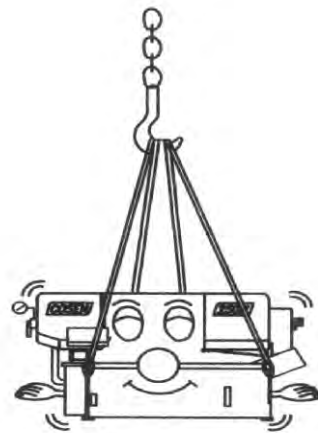
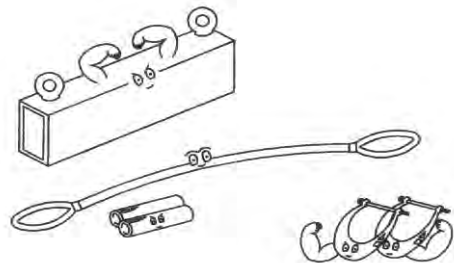
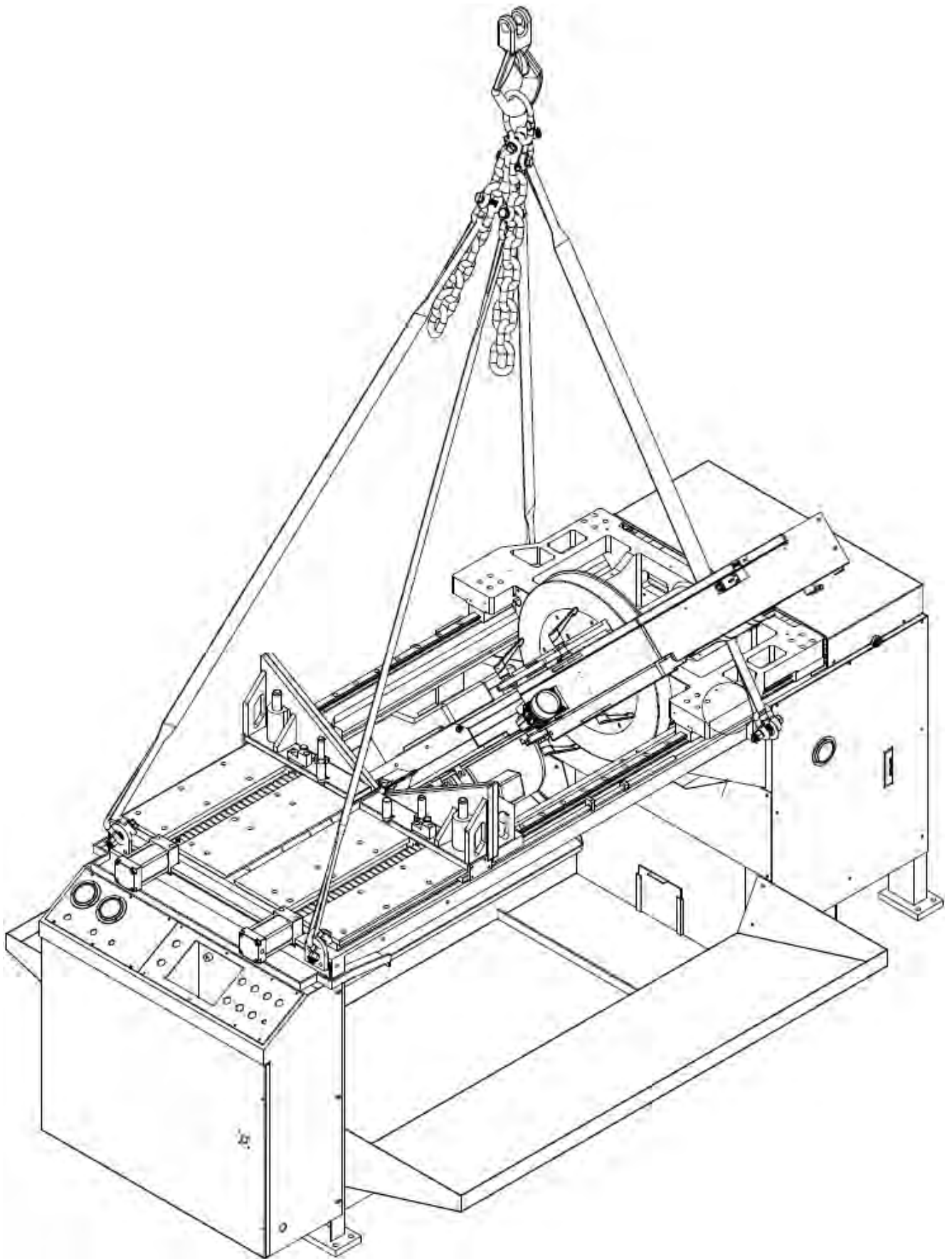

Illustration: Lifting Points



Minimum weight capacity for each wire rope: **2.5 ton**

Require: **4 fiber double ply slings (2,000 x 50mm; 78.7 x 2 inch), 8 shackles (5/8), 10 interlocking rings (Φ20), and 1 oval alloy steel ring (5/8)**

2. Use a forklift

Most users choose this method to move their machine because it is easy to set up. Make sure that the lifting rod can fully withstand the weight of the machine. (Refer to *Section 2 – General Information for Specifications*)

- Machine lifting is likely to damage the machine if not performed properly.



You must have a qualified forklift operator to perform the job.



- You must apply proper forklift technique to avoid damage to the machine.



Make sure the forks are able to reach in at least 2/3 of the machine depth.

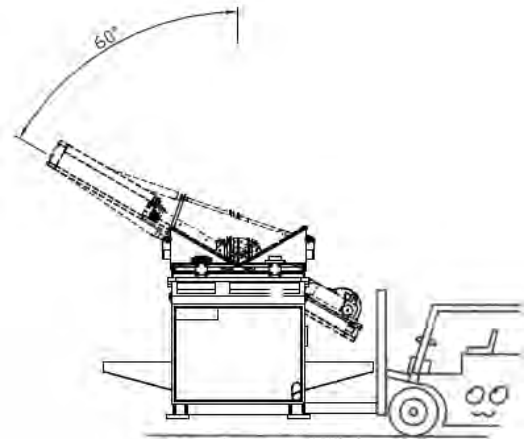

- You must keep the machine balanced at all times.



Make sure the forks are centered before use.

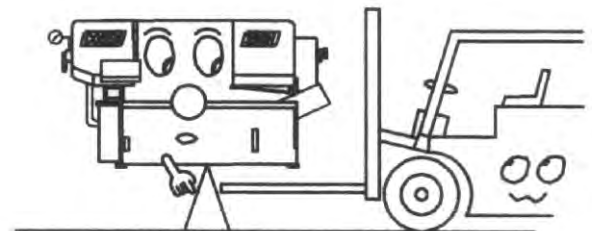

(Illustration only. Please follow user guide of your forklift.)

3. Use rolling cylinders

You can use rolling cylinders to move your machine in a small machine shop environment.

- You must use rolling cylinders made in material of proper compressive strength.

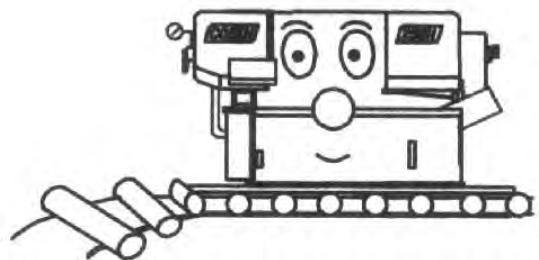

REMOVING SHIPPING BRACKET

- After the machine has been properly positioned, remove 2 shipping brackets that are used to lock the saw frame and the saw bed.
- Retain this bracket so that it can be used again in the event that your machine must be relocated.



CLEANING

After the machine has been placed at the designated position, remove the rust-preventive grease with wiping cloth dampened with cleaning oil or kerosene. Apply machine oil to machine surfaces that are prone to rust.



Do not remove the rust-preventive grease with a metal scraper and do not wipe the painted surfaces with solvent as doing so would damage surface paint.

INSTALLING

Cosen's bandsaw machine is relatively easy to install. Follow these six easy steps to install your machine.

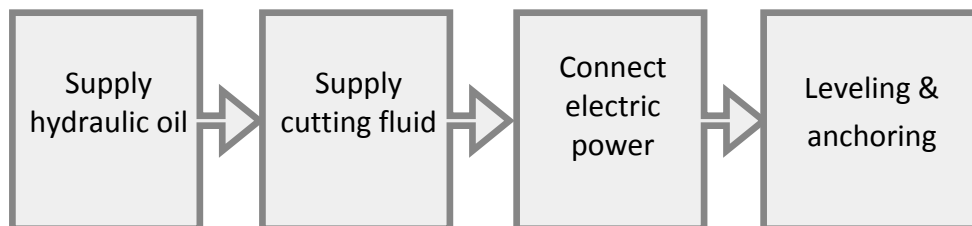

Supplying hydraulic oil

Open the filler cap and fill the hydraulic oil tank to above 2/3 or full level.

Check the sight gauge to make sure the oil level in the tank.



Refer to specification chart under Section 2 for tank capacity.





Oil tank should be full already if it is a new machine that operates for the first time.

Supplying coolant

Fill the coolant tank to the middle level of the sight gauge by pouring the coolant from above the chip conveyor.

Use the sight gauge to check the coolant level remaining in the tank.



Always check the coolant supply before starting the machine. If the coolant pump is started without enough coolant supply in the tank, the pump and its drive motor may be damaged.



Refer to specification chart under Section 2 *Specification* for tank capacity.



Consult your coolant supplier for bandsaw use regarding coolant type and mix ratio.

Connecting electric power



Have a qualified electrician make the electrical connections.



If the power supply voltage is different from the transformer and motor connection voltage shown on the label attached to the electrical compartment of the machine, contact COSEN or your agent immediately.



Connect to power supply independently and directly. Avoid using the same power supply with electric spark machines such as electric welder. Unstable electric tension may affect your machine's electric installation from working properly.



Ground the machine with an independent grounding conductor.



Supply voltage: 90% - 110 % of nominal supply voltage.



Source frequency: 99% - 101 % of nominal frequency.



Refer to the specification chart under Section 2 for total electric power consumption of the motors and make sure your shop circuit breaker is capable of this consumption amount. Also use a power supply cable of proper size to suit the power supply voltage.

1. Turn off the shop circuit breaker.
2. Make sure the machine circuit breaker switch on the electrical compartment door is turned to OFF.
3. Remove the screw securing the electrical compartment and then open the door.
4. Pull the power supply cable and grounding conductor through the power supply inlet into the electrical compartment. (Shown right)
5. Connect the power supply cable to the circuit breaker (N.F.B.) to the R, S and T terminals, and connect the ground cable to the E terminal.
6. Close the compartment door and fasten the screw back.
7. Turn on the shop circuit breaker and then turn the machine circuit breaker switch to ON. The *Power Indicator* on the control panel will come on.
8. Pull to unlock the *Emergency Stop* button and press the *hydraulic ON* button to start the hydraulic motor.
9. Make sure the sawing area is clear of any objects. Start the blade and check the blade rotation. If the electrical connections are made correctly, the blade should run in a counterclockwise direction. If not, shut the hydraulics off, turn off the machine as well as the shop circuit breaker. Then swap the power the power cable conductors connected to R and T terminals.
10. Repeat step 6 to 9 to ensure the electrical connections are in the right order.

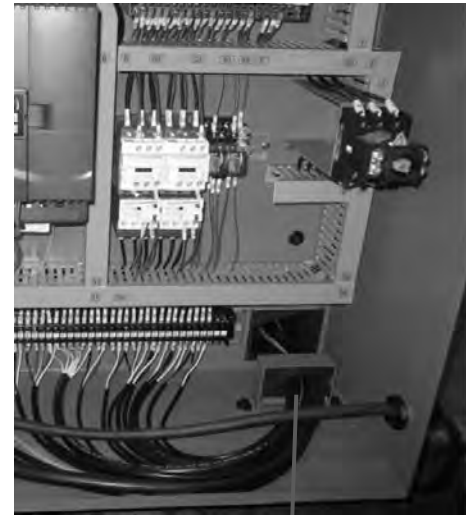

Power Supply Inlet

Leveling

Place spirit level on the vise slide plates and the work feed table.

Level the machine in both directions i.e. along and across the machine. Adjust the level of the machine by turning the leveling bolts.



Make sure all leveling bolts evenly support the machine weight.



In some cases, leveling the machine with a slight slope toward the front of the machine is recommended as it would prevent coolant from running down cutting material especially tubes or bundles. To do so, make the rear end of the machine approximately 10 mm higher than the level of the front end.

Anchoring the machine

Normally there is no need to anchor the machine. If the machine is likely to vibrate, fix the machine to the floor with anchor bolts.

Shock absorption steel plates are provided and can be placed under each leveling bolt to prevent their sinking into the concrete floor.

Installing Fire Control Device

Install a fire extinguisher or any other fire control device in the shop in case a fire breaks out.

RELOCATING

We recommend you follow these procedures when relocating or shipping your machine to other place:

1. Descend the saw frame to its lowest position then turn off the power.
2. Fix the saw frame using the shipping bracket that originally came with the machine.
3. If you are shipping the machine, pack the machine carefully with industrial plastic wraps to protect it from dust.
4. Use a crane or forklift to raise it. If a crane is used to lift the machine, ensure that the lifting cable is properly attached to the machine.
5. Do not forget to include the equipments originally furnished including the shock absorption steel plates and the instruction manual.

OPERATING INSTRUCTION

SAFETY PRECAUTIONS

BEFORE OPERATING

CONTROL PANEL

STANDARD ACCESSORIES

UNROLLING & INSTALLING THE BLADE

ADJUSTING WIRE BRUSH

ADJUSTING COOLANT FLOW

ADJUSTING BLADE SPEED

BREAKING-IN THE BLADE

TEST-RUNNING THE MACHINE

ADJUSTING SAW BOW INCLINING ANGLE

INSTALLING 90° VISE PLATES & TOP CLAMPS

CUTTING OPERATION

TERMINATING A CUTTING OPERATION

SAFETY PRECAUTIONS

For your safety, please read and understand the instruction manual before you operate the machine.

The operator should always follow these safety guidelines:

- The machine should only be used for its designated purpose.
- Do not wear gloves, neckties, jewelry or loose clothing/hair while operating the machine.
- For eye protection, always wear protective safety glasses.
- Check the blade tension and adjust blade guides before starting the machine.
- Use auxiliary clamping or supporting devices to fix material in place before cutting long workpieces. Always make sure the material is clamped firmly in place before starting to cut.
- Do not remove jammed or cut-off pieces until the blade has come to a full stop.
- Keep fingers away from the path of the blade.
- Protection devices should be in place at all times. For your own safety, never remove these devices.
- Disconnect machine from the power source before making repairs or adjustments.
- Wear protection gloves only when changing the blade.
- Do not operate the machine while under the influence of drugs, alcohol or medication.
- Do not take your eyes off the machine while in operation.
- Do place warning signs to mark out machine work zone and restrict entry to be staff-only.

BEFORE OPERATING

Choosing an appropriate saw blade and using the right cutting method is essential to your cutting efficiency and safety. Select a suitable saw blade and cutting method based on your work material and job requirements e.g. cutting accuracy, cutting speed, economic concern, and safety control.

Wet cutting

If you choose dry cutting or low-speed cutting, the chips may accumulate in machine parts and may cause operation failure or insulation malfunction. We suggest you choose wet cutting to avoid machine damage.

Cutting unknown materials

Before cutting an unknown material, consult the material supplier, burn a small amount of chips from the material in a safe place, or follow any other procedure to check if the material is flammable.



Never take your eyes off the machine while in operation.

Cutting fluid

For cooling and lubrication purpose, we recommend you use water-soluble cutting fluids. The following table lists out its pros and cons for your reference.

Pro	Con
<ul style="list-style-type: none">• Have a high cooling effect• Not flammable• Economical• Does not require cleaning of the cut products	<ul style="list-style-type: none">• Remove machine paint• Lose its rust protection effect if deteriorated• Tend to create foam• Subject to decay• Decline in performance, depending on the quality of the water used for dilution



Never use water as your coolant.



Always add coolant into water for better mix result.



Consult your coolant supplier for bandsaw use regarding coolant type and mix ratio.



Before starting a cutting job, make sure there is sufficient amount of coolant in the tank.

Check the fluid level through the sight gauge. Please refer to machine specifications in this manual (Section 2) for tank capacity.

CONTROL PANEL

The control panel is located on the top of the electrical box. It includes the following function: power system, hydraulic system, cooling system, the human-machine–interface (HMI) and the projecting light system. The operator must fully understand the function of each switch and button before operating the machine.

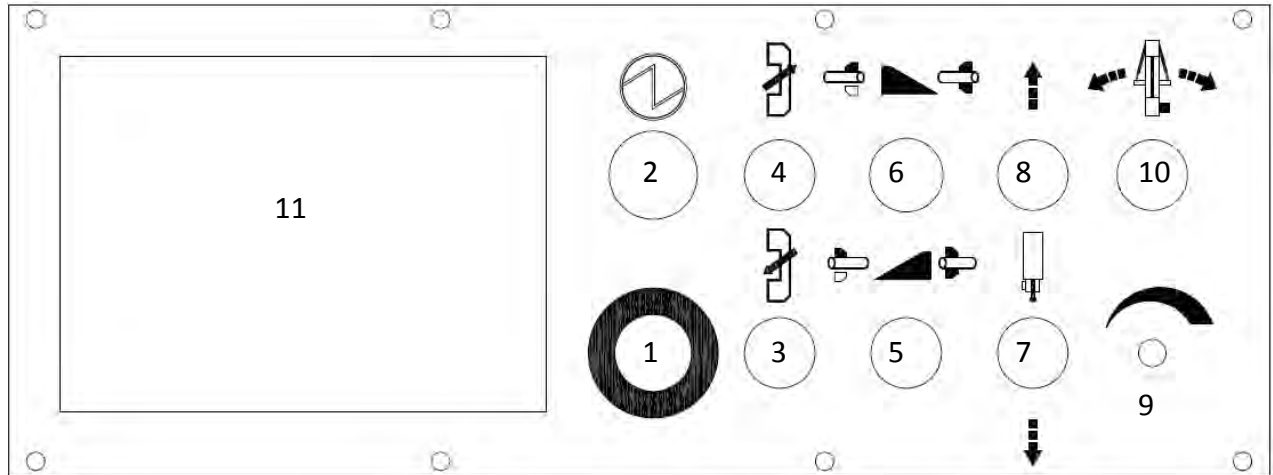

No.	Name	No.	Name
1	Emergency stop button	7	Guide arm down button
2	Power indicator lamp	8	Guide arm up button
3	Saw bow forward button	9	Blade speed control knob
4	Saw bow backward button	10	Saw bow angle control knob
5	Right vise clamp/release knob	11	HMI touch screen
6	Left vise clamp/release knob		

Control Buttons

1. Emergency stop button

Press this button to stop the machine in an emergency. When the button is pressed, it brings the machine to a full stop. The button locks when pressed. In order to unlock it, please turn the button clockwise.

2. Power indicator lamp

When the lamp is on, it indicates the power to the machine is turned on.

3. Saw bow forward button

When this button is pressed with the running blade, saw bow moves forward slowly. When this button is pressed with the stopped blade, saw bow moves fast forward until the operator releases the button.

4. Saw bow backward button

When the button is pressed, saw bow moves backward until the operator releases the button or until the saw bow reaches the rear limit position.

5. Right vise clamp/release knob

Turn the knob to the left for clamping the material. Turn the knob to the right for releasing the material.



Cutting can be started with either left vise or right vise clamping, but for better performance, use both left and right vises to clamp the material.

6. Left vise clamp/release knob

Turn the knob to the left for clamping the material. Turn the knob to the right for releasing the material.



Cutting can be started with either left vise or right vise clamping, but for better performance, use both left and right vises to clamp the material.

7. Guide arm down button

When this button is pressed, guide arm descends until the operator releases the button.



When adjusting guide arm, please avoid hitting the material.



The closer the guide arm approaches the workpiece, the better the stability of cutting.

8. Guide arm up button

When this button is pressed, guide arm rises until the operator releases the button.

9. Blade speed control knob

Blade speed is controlled by the inverter. Turning the knob clockwise increases the blade speed.



BLADE SPEEDS FOR BI-METAL BLADES

MATERIAL	AISI-SAE OR TRADE NAME	FPM
Structurals	A36	330
Low Carbon	1005-1012	320
	1015-1030,1513-1536	330
Medium Carbon	1033-1055	230
High Carbon	1080-1080,1541-1572	200
	1084-1095	185
Low Carbon-Resulfurized	1108-1110,1211-1215	340
	1116-1119	350
Medium Carbon-Resulfurized	1132-1151	270
Alloy Steel	4418,4130	270
	4135,4137,4140,4142	250
	4145,4147,4150,4161	210
	4337,4340	220
	8515,8617,8620,8622	240
Tool Steels	A-2,A-3,A-5,A-9	200
	D-2,D-5	110
	M-1,M-2	120
	M-3,M-4	100
	T-1 THRU T-6	140
Stainless Steel	201,202,301,302,304	120
	309,309s,310	75
	316,316L,317,330	80
Cast Iron	Class 20	180
	Class 40	130
	Class 60	110
Ductile Iron	60-40-18	270
	100-70-03	120
	120-90-02	75
Titanium Alloy	Commercially Pure	80

Above speeds are for cutting 4" material (with 3/4 pitch) when using a cutting fluid.
 Increase speed 15% for 1/4" material with 10-14 tooth blade
 1% for 3/4" material with 6-8 tooth blade
 4% for 1-1 1/2" material with 3-8 blade
 5% for 2-1 1/2" material with 4-8 tooth blade
 Decrease speed 11% for 3" material with 2-3 tooth blade

10. Saw bow angle control knob

- When the knob is turned to the left, saw bow inclines to the left. When saw bow reaches 150° and touches the left limit switch, saw bow left limit switch red light on HMI touch screen is triggered and saw bow stops.
- When the knob is turned to the right, saw bow inclines to the right. When saw bow reaches 30° and touches the right limit switch, saw bow right limit switch red light on HMI touch screen is triggered and saw bow stops.



Return-to-zero point of angle encoder is installed at 150°. Angle can be adjusted in HMI (angle margin of error: 0.2°). Refer to below figure for the definition of angle.

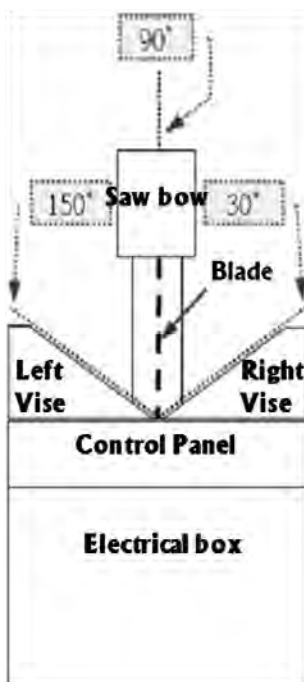



This control knob only works when the saw bow is at rear limit position.



IF 90° VISE PLATES ARE INSTALLED, DO NOT SWIVEL SAW BOW. OTHERWISE, SAW BLADE WILL CUT THE VISE PLATES.

11. HMI touch screen

Please refer to later section for detailed introduction.

Cutting pressure, vise pressure, and feeding speed control panel

The part of control panel is where cutting pressure, vise pressure and saw bow feeding speed can be adjusted.



1. Cutting pressure control knob

- This pressure control knob is used to adjust the cutting pressure of the blade.
- Turning the knob clockwise increases the cutting pressure.

2. Vise pressure control knob

- This pressure control knob is used to adjust the vise pressure.
- Turning the knob clockwise increases the vise pressure.
- Adjust vise pressure according to different material, i.e. pipe, steel bar, H beam.
- When cutting pipes or soft materials, reduce vise pressure to prevent exerted pressure from damaging the workpiece shape or exterior.



Vise pressure should not be adjusted during cutting.



Vise pressure cannot be lower than 8 kg/cm².

3. Saw bow feeding speed control knob

- This control knob is used to adjust the feeding speed of the saw bow.
- Turning the knob counterclockwise increases the saw bow feeding speed.
- Saw bow feeding speed is a determining factor to a good cutting time and quality cutoff surface.
- Set the saw bow feeding speed in accordance with the *cutting pressure control* knob.
- Also commonly known as the flow control valve

Human-machine-interface (HMI) touch screen

This HMI touch screen displays operation messages so that the operator is able to understand the system condition. It also provides different operating modes and selections for the operator to work with. During a cutting job, the operator can still enter the system and make changes to the cutting operation as needed.



Do not wipe or clean the screen with volatile solvents.



Do not overexert pressure on the screen. The touch screen is very sensitive; all buttons on the screen just need a slight touch to operate.



All range parameters in HITECH 5.7" are configured under the "manual" mode.



Please pay attention to the following environment conditions necessary for HITECH 5.7" HMI touch screen to properly operate:

Item	Range
Ambient temperature	5°C ~ 50°C
Temperature for safe operation	-10°C ~ 60°C
Ambient humidity	30%~85% RH (No condensation)
Connection	RS422 MMI port
Environment	No condensation and rust



Startup Screen











After the power is turned on, Cosen's logo will appear as the startup screen, followed by the main operation menu..













Main control menu





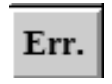



The main control menu includes some operating button that were used on the control panel of the earlier machines. Some convenient functions are added to the page for the operator to better understand the features of the machine. Setting the parameters shown on the screen requires a gentle touch of the finger. You can also look up the parameters or make changes while in the middle of a cut.

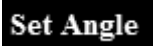
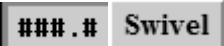

Refer to the table below for descriptions of each function.

No	Item	Function	Description
1		Hydraulic start	<p>When the power is turned on, press this button to start the hydraulic motor.</p> <p>A solid yellow icon indicates the hydraulic system has been turned on.</p>
2		Hydraulic stop	<p>Press this button to turn off the hydraulic motor immediately.</p> <p> When the blade is running, the hydraulic stop button is temporarily disabled. You need to press the <i>saw blade stop</i> or the <i>saw bow backward</i> button to stop the blade first.</p>
3		Saw blade start	<p>When the work piece is clamped properly, press this button to start cutting.</p> <p>A solid yellow blade icon indicates the blade has been started.</p> <p> When the blade is running, all the buttons are temporarily disabled except the emergency stop button, saw bow backward button, blade speed control knob, and saw bow feeding speed control knob. When cutting is finished, all the control buttons resume function.</p>
4		Saw blade stop	Press this icon to stop the saw blade.
5		Work light ON/OFF	<p>Press this button to turn on the work light.</p> <p>A solid yellow light bulb icon indicates the lamp has been turned on.</p> <p>Press again to turn the light off.</p>
6		Coolant ON/OFF	<p>Press this button to turn on the coolant pump.</p> <p>A solid yellow faucet icon indicates the coolant pump has been turned on.</p> <p>Press again to turn off the coolant pump.</p>
7		Last cut function ON/OFF	When the  mode is selected, the blade will automatically stop and the hydraulic system will shut down (in 10 seconds) after the current cut is finished.
8		Left vise lock/unlock	<p>Press this button to lock/unlock left vise.</p> <p>Lock the left vise and vise clamping light must be on, otherwise blade will not start cutting.</p>

No	Item	Function	Description
9		Right vise lock/unlock	Press this button to lock/unlock right vise Lock the right vise and vise clamping light must be on, otherwise blade will not start cutting.
10		Saw bow fast/slow swiveling mode	When the slow mode is turned on, the saw bow swiveling speed will dramatically reduce to help you position the work piece precisely
11		non-90°/90° vise plates mode	If installing 30° and 45° vise plates, choose non-90° vise plates mode. If installing 90° vise plates, choose 90° vise plates mode. Under 90° vise plates mode, saw bow cannot swivel so saw blade will not cut the vise plates.
12		System parameter setting	Press this button to set up system parameters. Password is required.  All parameters have been set up by the manufacturer. In order to prevent random change from being made to these parameters and affect cutting precision and machine life, this function is protected with a set of password.
13		Cutting status display	Press this button to display cutting-related information e.g. blade speed and blade life. Information and parameter setups for optional accessories such as blade deviation detector can also be configured in this setup page. Refer to Cutting Display & Setup in the following page.
14		PLC monitor	Shows current PLC signals.
15		Material cutting reference	This 2-page reference chart lists out the required blade speed and cutting rate for each different material.
16		Error report	Lists a historical report of the errors and the time of occurrence as well as provides troubleshooting support. 6 pages in total.
17		Saw bow left limit switch indicator	When saw bow touches left limit switch and red right is on, it means saw bow inclines left max. 150°.
18		Saw bow right limit switch indicator	When saw bow touches right limit switch and red light is on, it means saw bow inclines right max. 30°.
19		Saw bow rear limit switch indicator	After the cut is finished, blade will stop running and saw bow will move backward automatically until it touches the rear limit switch and the RED light will come on.

No	Item	Function	Description
20		Saw bow front limit switch indicator	<p>When saw bow cuts or moves forward and touches the front limit switch, the RED light will come on which means the cut is finished or saw bow already reaches the end.</p> <p> All limit switches have been set up by the manufacturer before shipment. Make random changes will affect cutting precision.</p>
21		Guide arm safety position indicator	<p>Indicates if the guide(saw) arm is within its safety range for the saw bow to move forward. This safety design prevents the saw arm from being improperly positioned and hitting the workbed while blade moves forward.</p> <ul style="list-style-type: none"> • Light on: Saw bow has reached the minimum height and is not allowed to descend any further. Raise the saw bow again, check on the saw arm position and move it to a safer place. • Light off: Saw arm is at a proper height and within the safe range.
22	 	Angle setting	<p>Key-in ###.# in HMI, press “Swivel” and saw bow inclines to the setting angle.</p> <p> Saw bow must be at rear limit switch position to swivel. Do not swivel saw bow if installing 90° vise plates. Otherwise saw blade will cut the vise plates.</p> <p> When adjusting the angle of saw bow manually, actual angle and angle displayed on the screen need to match for the machine to start cutting.</p>
23		Blade speed display	Displays current blade speed.
24		Miter angle display	Displays the current angle the saw bow is swiveled at.
25	 (yellow highlight)	Error display	<p>Displays error messages in the order of occurrences; press the message to clear the messages.</p> <p> Error messages must be cleared for the machine to continue to operate normally.</p>

Cutting status display & setup

When cutting is in operation, press **NEXT** to enter cutting status display and setup page.

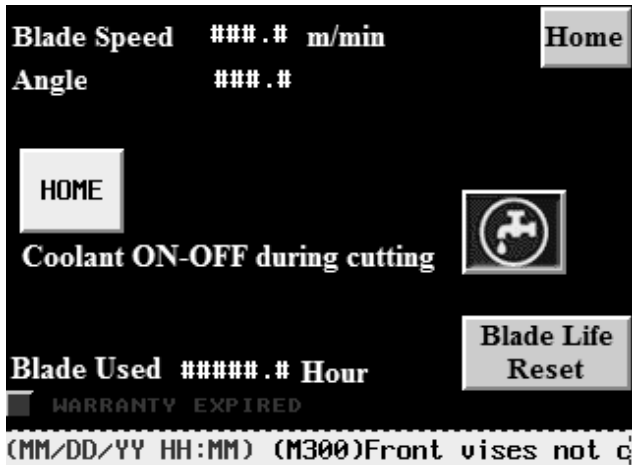

(Display without optional spray device included)

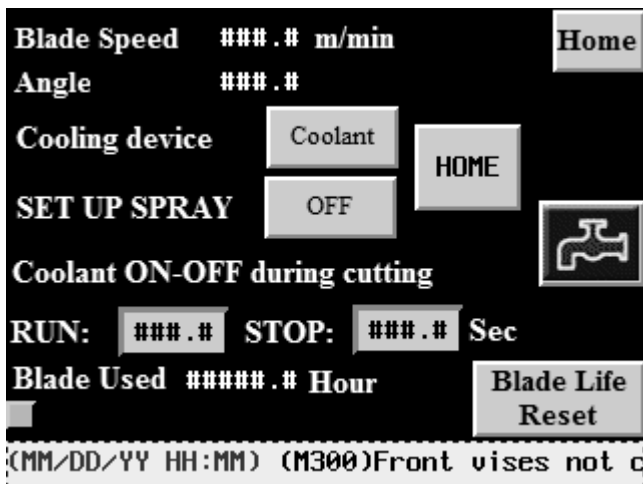

(Display with optional spray device included)

Cutting status display & setup

This page comes in two versions depending on if the optional mist coolant spray device is installed on the machine. The shared features are as follows:

- Blade speed
- Angle: mitering angle
- **HOME(Return-to-zero point)** – After machine is restarted, this icon will turn grey. When this icon is pressed, saw bow will swivel to return-to-zero point, left 150°, and back to 90° and the icon will turn yellow. Thus, blade can be started.



This button must be yellow to start the blade.

- **Coolant On/Off during cutting** - Press this faucet icon to allow coolant pump start automatically during cutting.
- **Blade Used** - Current blade life in hours
- **Blade Life Reset** – Reset the blade life to zero
- **Warranty status** - The green square light on the bottom left corner indicates the warranty status of the HMI touch screen. Warranty is one year and starts counting after 70 hours of operation after the machine is shipped. Warranty status light turning to red indicates the HMI touch screen has expired.
- **Error messages**- (highlighted in yellow; can be cleared by pressing down for 1~2 seconds)
- Press **Home** to return to the main control menu.

For machines with optional spray device installed, additional two command are provided:

- **Cooling device**: press this button to use either coolant or spray
- **SET UP SPRAY**: press this button to turn on/off the spray. When both this button and the *coolant ON/OFF* button on main control menu are turned on, spray device can be started manually.
- **RUN**: press this button to set up how long the spray will run if using the spray
- **STOP**: press this button to set up how long the spray will stop if using the spray

Moni PLC Monitor

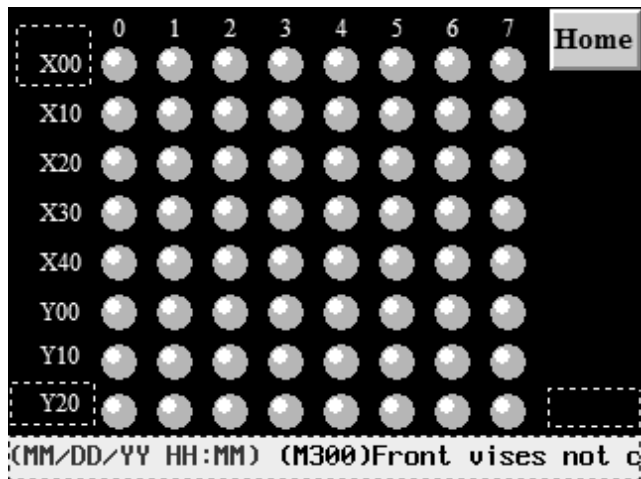

- Shows all signals of the PLC system.
- Press **Home** to return to the main control menu.

Mtrl Material cutting reference

THE TABLE OF CUTTING RANGE < JIS >		
MATERIAL	BLADE	CUTTING RATE
01 S20C-S35C	65 - 90	70 - 108
02 S40C-S50C	65 - 90	70 - 100
03 S9CK-S15C	80 - 110	60 - 90
04 S53C-S58C	65 - 90	60 - 80
05 SS50	65 - 90	60 - 70
06 SS41	65 - 90	55 - 70
07 SM50	54 - 50	50 - 56
08 SCM3	54 - 80	65 - 80
09 SUP5	54 - 80	40 - 55
10 SRC 3,4	54 - 80	40 - 55
11 SCMM22	54 - 80	40 - 50
12 SNC1	54 - 80	40 - 50
13 SNC22	54 - 80	35 - 45
14 SNCMM22	54 - 80	35 - 45

- This 2-page reference chart lists out the required blade speed and cutting rate for each different material.
- Press **Home** to return to the main control menu.
- Press **Next** to go to the next page.

Err. Error report

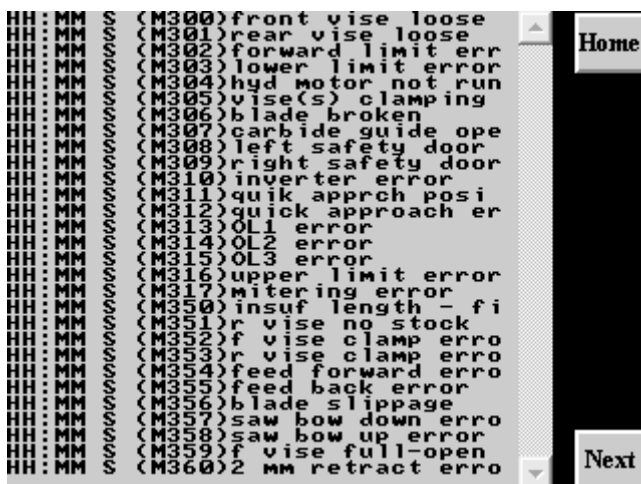

Page 1 – error report

- Lists a historical report of the errors and the time of occurrence.
- Press **Home** to return to the main control menu.
- Press **Next** to go to the troubleshooting support page.

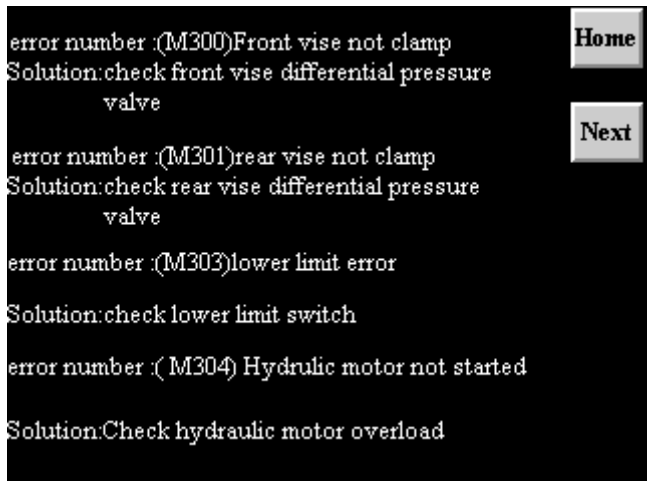

Page 2 – troubleshooting

- Provides suggestions on troubleshooting. 9 pages in total.
- Also refer to below Table for error codes, descriptions and solutions.
- Press **Home** to return to the main control menu.
- Press **Next** to go to the troubleshooting support page.



Error Code	Error Description	Solution
M300	Front vises not clamping	Check if the queen valve works
M301	Rear vises not clamping	Check if the queen valve works
M303	Lower limit switch error	Check if the lower limit switch works
M304	Hydraulic motor not starting	Check if the hydraulic motor works
M306	Broken blade detected	1. Check the blade motion detector01 2. Check if the blade is broken
M308	Left safety door abnormal	1. Check if the left safety door is shut properly 2. Check if the left safety door limit switch works
M309	Right safety door abnormal	1. Check if the right safety door is hut properly 2. Check if the right safety door limit switch works
M312	Quick approach bar abnormal	Check if the quick approach limit switch works
M313	Blade motor overload	Check if the blade motor overload relay has tripped
M314	Hydraulic motor overload	Check if the hydraulic motor overload relay has tripped
M315	Coolant pump overload	Check if the coolant pump motor overload relay has tripped
M316	Saw bow upper limit abnormal	Check the upper limit switch works
M352	Front vise clamping error	1. Place new material 2. Check if the vise queen valve works 3. Check if the “no material parameter” is too low

Error Code	Error Description	Solution
M357	Saw bow descending error	<ol style="list-style-type: none"> 1. Check if the descend solenoid valve is stuck 2. Check the quick approach bar works 3. Check if the quick approach bar limit switch works
M358	Saw bow ascending error	<ol style="list-style-type: none"> 1. Check if the ascend solenoid valve is stuck 2. Check the quick approach bar works 3. Check the quick approach bar limit switch works
M361	No material	<ol style="list-style-type: none"> 1. Place new material 2. Check if the vise queen valve works 3. Check if the “no material parameter” is too low
M363	PLC battery voltage too low	Replace PLC battery
M368	Left visenot set in function/clamping	Reset or clamp left vise
M369	Right visenot set in function/clamping	Rest or clamp right vise
M370	Mitering angle different from preset angle	<ol style="list-style-type: none"> 1. Swivel saw bow by pressing “swivel” button 2. Reset mitering angle
M371	Abnormal blade retraction upon completed cut	<ol style="list-style-type: none"> 1. Check the saw bow rear limit switch 2. Check the solenoid valve 3. Check PLC output Y12
M372	Saw bow NOT at rear limit	<ol style="list-style-type: none"> 1. Send saw bow to rear limit switch position 2. Check rear limit switch
M373	Saw arm not in safe position	Raise saw arm to upper limit position
M374	Saw bow not initial	Saw bow implement initial

STANDARD ACCESSORIES

Blade tension device



- This blade tension device equipped with hydraulic cylinder provides appropriate tension to the saw blade.
- To tighten the saw blade, turn the selector to .
- Upon saw blade breakage, the safety device will activate and automatically stop all machine operation.
- The limit switch of the safety device can be reset by turning the blade tension selector to .
- To change the blade, turn the handle to  to release saw blade tension.

Blade speed/motion detector



- Besides detecting the blade speed, the speed/motion detector also functions as a safety device.
- The speed/motion detector protects operators and the machine by preventing blade overloads and consequent damages if a saw blade breaks or skids.
- Once blade breakage or slippage is detected, the drive wheel will stop in 10 seconds.

Inverter



This inverter is installed inside the machine base. It is used to control and stabilize the saw blade speed during cutting. To adjust blade speed, use the blade speed control knob on the control panel.



Note:

1. Make sure the terminal points are connected.
2. Make sure the ambient temperature is within acceptable range and keep the surroundings well ventilated.
3. Keep the inverter away from dust.
4. For repair or maintenance, please contact your local agent.

Gear reducer



The specially designed gear reducer can work toward your preset blade speed and torque.



Please refer to Section 8 for information on maintenance.

Coolant pump



The coolant pump supplies coolant to cool off cutting temperatures during cutting. Also, it can be used to wash off chips.

Hydraulic powered wire brush



The wire brush removes the metal chips on the saw blade teeth so that blade life can be extended.



Keep hands away from the brush while the wire brush is running.



Turn off the hydraulic motor or the main power switch before performing maintenance or cleaning on the wire brush drive system.

Spray system



On HMI screen, choose to use either coolant or spray system to clean the chips. Also set up how long the spray will run and stop on HMI.

UNROLLING & INSTALLING THE BLADE



Always wear leather gloves and protection glasses when handling a blade.

Unrolling the blade

Please follow the procedures illustrated below.

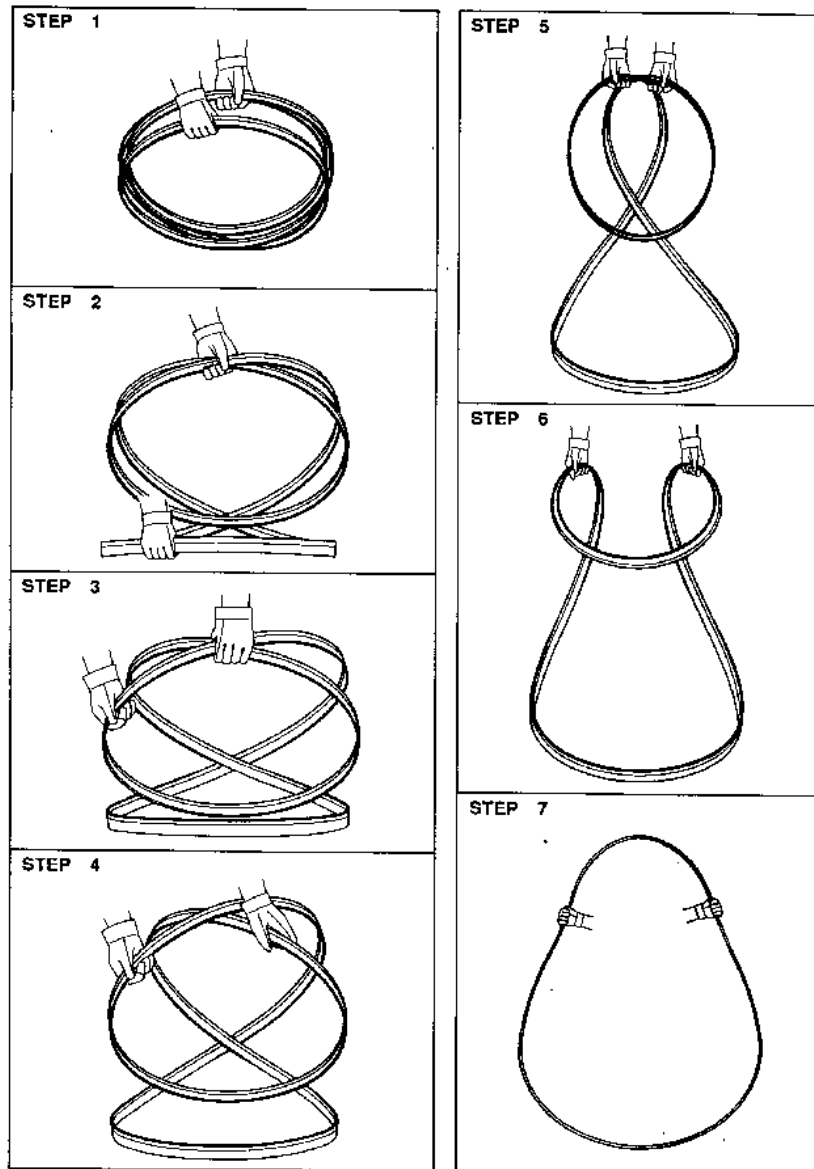



Installing a new blade

Step 1 - Select the most suitable saw blade for your workpiece considering the size, shape and material.

Step 2 - Turn on the machine power by switching to *ON* and turn on the hydraulic system.

Step 3 - Move saw bow to rear limit switch position then swivel the saw bow to 30°.

Step 4 - Turn the tension controller handle from “” to “” position to release tension. The idle wheel will then move slightly toward the direction of the drive wheel.



Step 5 - Open the idle and drive wheel covers.

Step 6 - Loosen the blade cover.

Step 7 - Loosen the wire brush assembly screws and pull the wire brush away from the blade.

Step 8 - Pull the entire blade out.

Step 9 - If necessary, clean the carbide inserts before installing a new saw blade.

Step 10 - Place the new blade around the idle wheel and the drive wheel

Step 11 - Insert the blade into the carbide inserts. The back and the sides of the blade need to be touching the inserts as well as the adjacent rollers.

Step 12 - Place the blade to the drive wheel and press the back of the blade against the flange of the drive wheel.

Step 13 - Make sure the back of the blade is also pressed against the flange of the idle wheel.

Step 14 - Tighten the blade by moving the bolt up and tightening the nut.

Step 15 - Gently close the idle and drive wheel covers.

Step 16 - Swivel the saw head to 90°. Adjust wire brush to a proper position.

Step 17 - Press the *saw blade start* button to start the blade. Allow the blade to run for a few rotations then press the *saw bow backward* button to move the saw bow backward. Open the wheel covers and make sure the blade has not fallen off the drive and idle wheels. If the blade has shifted, follow the same procedure to reinstall the blade again.

ADJUSTING WIRE BRUSH

Follow these steps to adjust wire brush to appropriate position:

Step 1 – Loosen the adjustment screws.

Step 2 – Adjust the adjustment screws to make brush move left/right until it makes proper contact with the saw blade (see below illustration).

Step 4 – Tighten the adjustment screws.



Proper

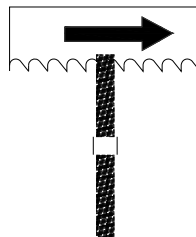

Improper

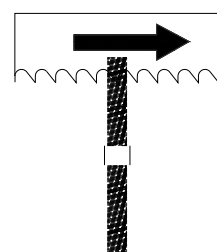

ADJUSTING COOLANT FLOW

Step 1 – Press the *saw blade start* button to start the saw blade drive motor.

Step 2 – Press the *saw bow forward* button to move the saw bow forward.

Step 3 – Use the flow control valve (shown below) to adjust the amount of fluid flowing to the cutting area.



Adjust the flow amount if you observe the following changes to the chips generated from cutting.



If the chips are sharp and curved, increase the coolant flow amount.

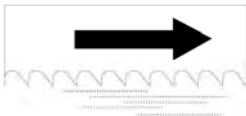

If the chips are granulated, decrease the coolant flow amount.

ADJUSTING BLADE SPEED

Step 1 – Set the flow control to “0” position.

Step 2 – Press the *saw blade start* button to start the blade.

Step 3 – Turn the *blade speed control knob* to adjust the blade speed. The blade speed should be adjusted based on the size and the material of the workpiece.

BREAKING-IN THE BLADE

When a new saw blade is used, be sure to first break in the blade before using it for actual, extended operation. Failure to break in the blade will result in less than optimum efficiency. To perform this break-in operation, the following instructions should be followed:

Step 1 - Reduce the blade speed to one-half of its normal setting.

Step 2 - Lengthen the cutting time to 2-3 times of what is normally required.

Step 3 - After the break-in operation is completed, set all parameters back to normal settings.

TEST-RUNNING THE MACHINE

Test-running this machine can ensure good machine performance in the future. We suggest you run the following tests on the machine before first use:

Testing machine performance:

Turn on the power and run a basic performance test after you finish installing the machine. Follow these steps to test machine performance:

Step 1 – Disassemble shipping brackets and bolts.

Step 2 – Install roller table (optional).

Step 3 – Turn on the relay switch in the control box.

Step 4 – Move the saw bow backward. (If your coolant pump is in reverse and the machine cannot run, please change the electrical phase.)

Step 5 – Remove the rust-prevention grease with cleaning oil or kerosene.

Step 6 – Start the coolant pump.

Step 7 – Test these functions:

- vise clamping/unclamping
- saw bow moving forward/backward

ADJUSTING SAW BOW INCLINING ANGLE

For this machine, the saw bow is a forward inclined type. It can be inclined from 0°~5°. Follow below steps to adjust the angle.

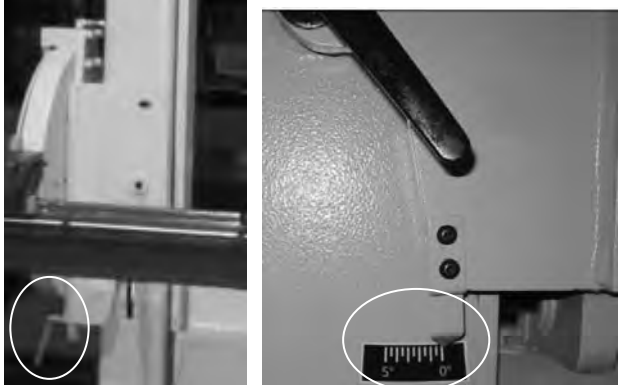
	<p>Step 1- Loosen fixed bolts x 4 (2 on each side).</p>				
	<p>Step 2- Adjust the angle of saw bow by adjustment handle.</p> <table border="1" style="width: 100%; border-collapse: collapse; margin-top: 10px;"> <tr> <td style="padding: 2px;">Clockwise</td> <td style="padding: 2px;">Backward (5°~0°)</td> </tr> <tr> <td style="padding: 2px;">Counterclockwise</td> <td style="padding: 2px;">Forward (0°~5°)</td> </tr> </table>	Clockwise	Backward (5°~0°)	Counterclockwise	Forward (0°~5°)
Clockwise	Backward (5°~0°)				
Counterclockwise	Forward (0°~5°)				
<p>Step 3- Fasten the fixed bolts.</p> <p> Saw bow inclined angle will affect cutting ability. Refer Section 2 for product specification.</p>					

INSTALLING 90° VISE PLATES & TOP CLAMPS

Step 1 - After the machine has been properly positioned, remove 2 shipping brackets that are used to lock the saw frame and the saw bed. Retain these brackets so that they can be used again in the event that your machine must be relocated.



Step 2 - Move the saw bow backward until it reaches the rear limit position and the rear limit indicator light turns on. Press “Home” button to move machine to home position.

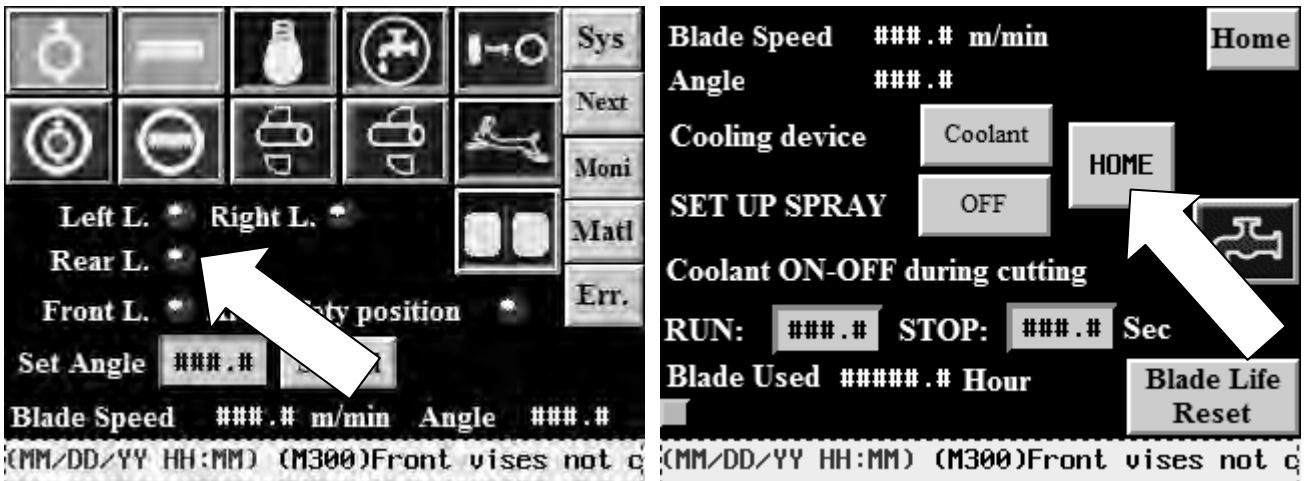

Step 3 - Remove 30° vise plates. Install 90° vise plates. Install top clamps. Washers and screws of the 90° vise plates need to be tightened securely.





Step 4 - Press to select “90° vise plates” mode so saw bow cannot swivel.



Under “90° vise plates” mode, “HOME” buttons and saw bow angle control knob are temporarily disabled to avoid saw bow swiveling.

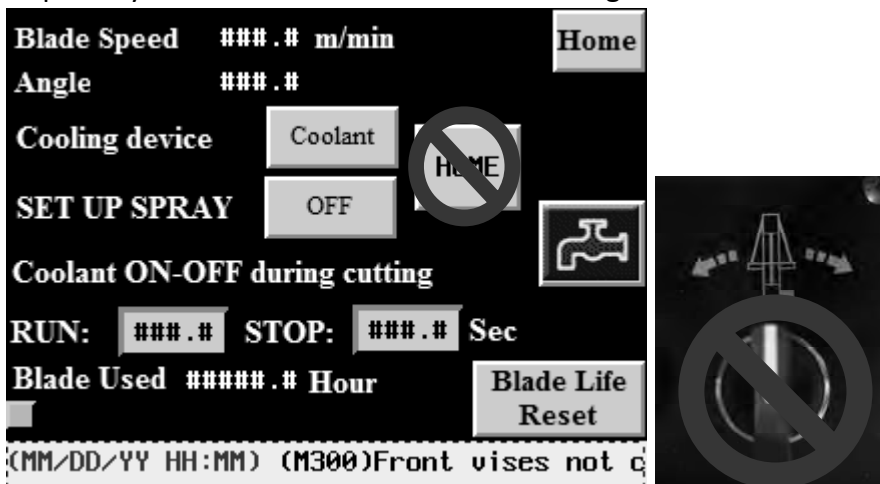

Step 5 - After the workpiece is clamped by the vises, turn the manual direction valves of the top clamps to clamp the workpiece.

Note the allowable clamping width and height. (Refer to *Section 2 – General Information, Specifications*)



CUTTING OPERATION

Step 1 – Check before you cut

- **Power:** Check the voltage and frequency of your power source.
- **Coolant:** Check if you have sufficient coolant in the tank.
- **Hydraulic:** Check if you have sufficient (at least two-thirds or higher) hydraulic oil.
- **Workbed:** Check if there is any object on the feeding bed that may cause interference.
- **Blade:** Check the blade teeth and make sure there is no worn out teeth along the blade.
- **Light:** Check the work lamp or laser light (optional) and make sure there is sufficient lighting.
- **Saw bow:** Check the saw bow to see if it can be forward and backward smoothly.

Step 2 – Place your workpiece onto the workbed manually or by using a lifting tool e.g. a crane.



Before loading, make sure the vises are opened to at least wider than the width of the workpiece.

Step 3 – Position your workpiece.

Step 4 – Clamp the workpiece.

Step 5 – Turn the *cutting pressure control* knob to adjust blade cutting pressure according to the material.

Step 6 – Adjust *saw bow feeding speed control* knob to obtain a suitable blade feeding speed for your material.

Step 7 – Start running the blade.



Before you start cutting, check again that there is no other object in the cutting area.

Step 8 – While the blade moves forward, adjust the blade speed if necessary. You can do so by turning the *blade speed control* knob, clockwise to speed up and counterclockwise to slow down. The blade speed is displayed in the HMI touch screen.

Step 9 – Select the proper cutting condition according to different material.

Step 10 – After the entire cutting job is completed, move the saw bow backward to the rear limit position and open the vises to remove the workpiece.

Step 11 – Clean the workbed by removing chips and cutting fluids.

Step 12 – Move the saw bow forward to a proper position then turn off the power.



TERMINATING A CUTTING OPERATION

- To terminate a cutting operation, press either the *saw bow backward* button or the *emergency stop* button.
- The saw blade will stop running when the *saw bow backward* button is pressed.
- Both the saw blade and hydraulic pump motors will stop running when the *emergency stop* button is pressed.
- The machine will stop automatically when an error occurs. The error message will be shown on the screen.

Section 5

ELECTRICAL SYSTEM

ELECTRICAL CIRCUIT DIAGRAMS

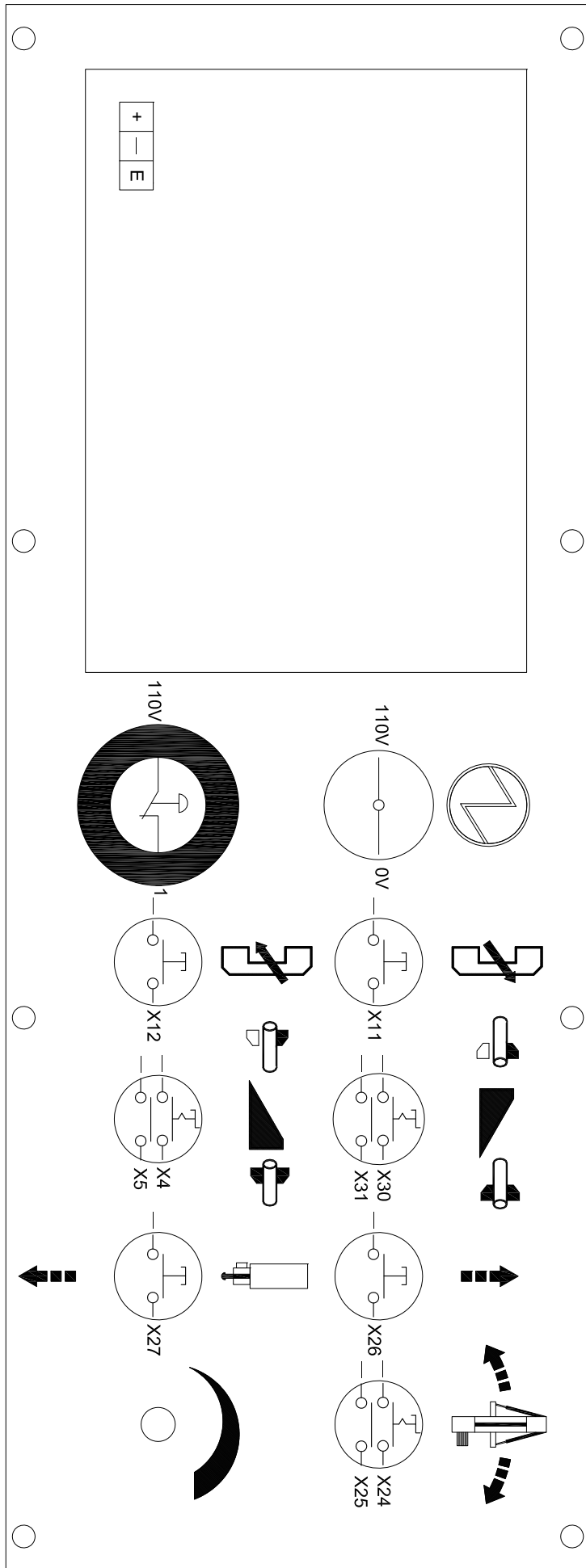

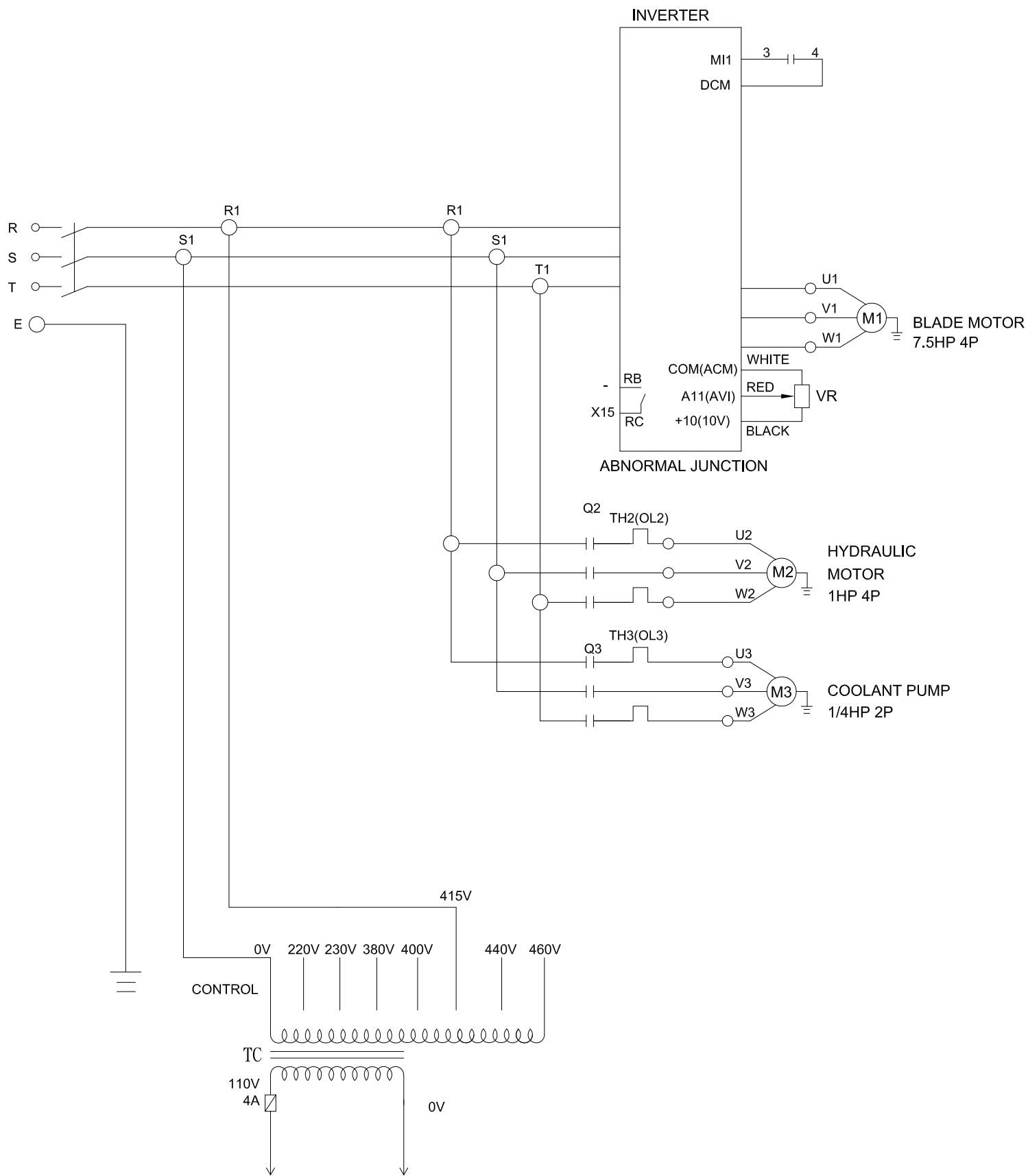

E	110V
0V	5
+	1
-	X4
X5	X11
X12	X24
X25	X26
X27	X30
X31	X31

TB1

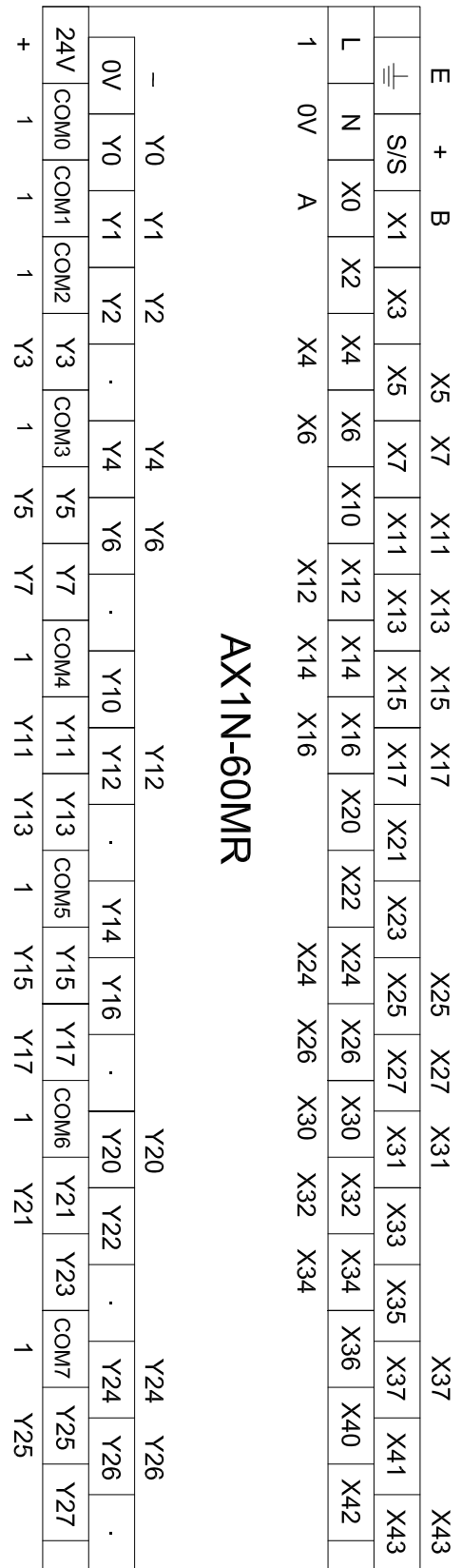

AX1N-60MR

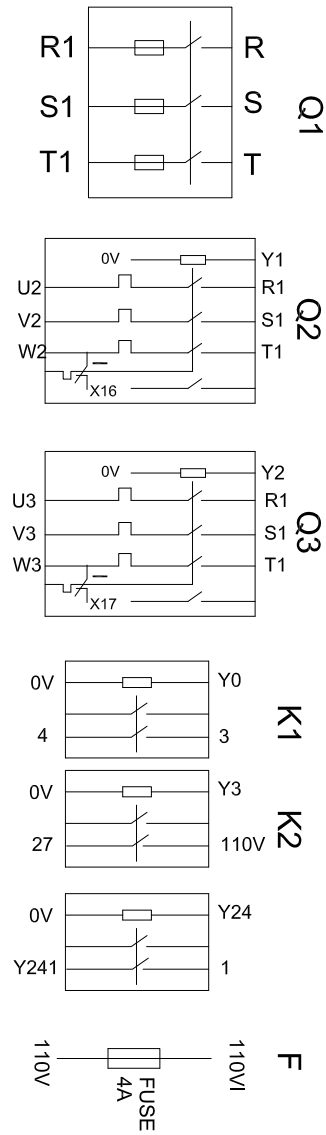

0V	220V	230V	380V	400V	415V	440V	460V	
TR								
0V	100V	110V						120V

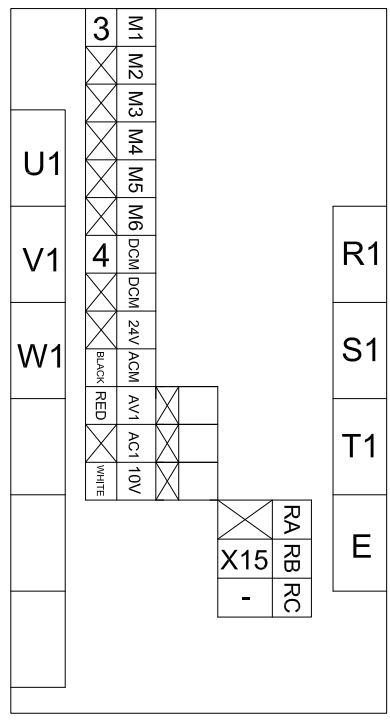

R	S	T	E	U1	V1	W1	E	U2	V2	W2	E	U3	V3	W3	E	A	B	+	-	X14	X6	X7	X13	+	-	X22	X32	X34	27	OV	Y4	Y5	Y6	Y7	OV	Y11	Y12	Y13	OV	Y15	Y17	OV	Y20	Y21	OV	Y25	Y26
---	---	---	---	----	----	----	---	----	----	----	---	----	----	----	---	---	---	---	---	-----	----	----	-----	---	---	-----	-----	-----	----	----	----	----	----	----	----	-----	-----	-----	----	-----	-----	----	-----	-----	----	-----	-----

TB2

TB3

ENCODER

B A + -

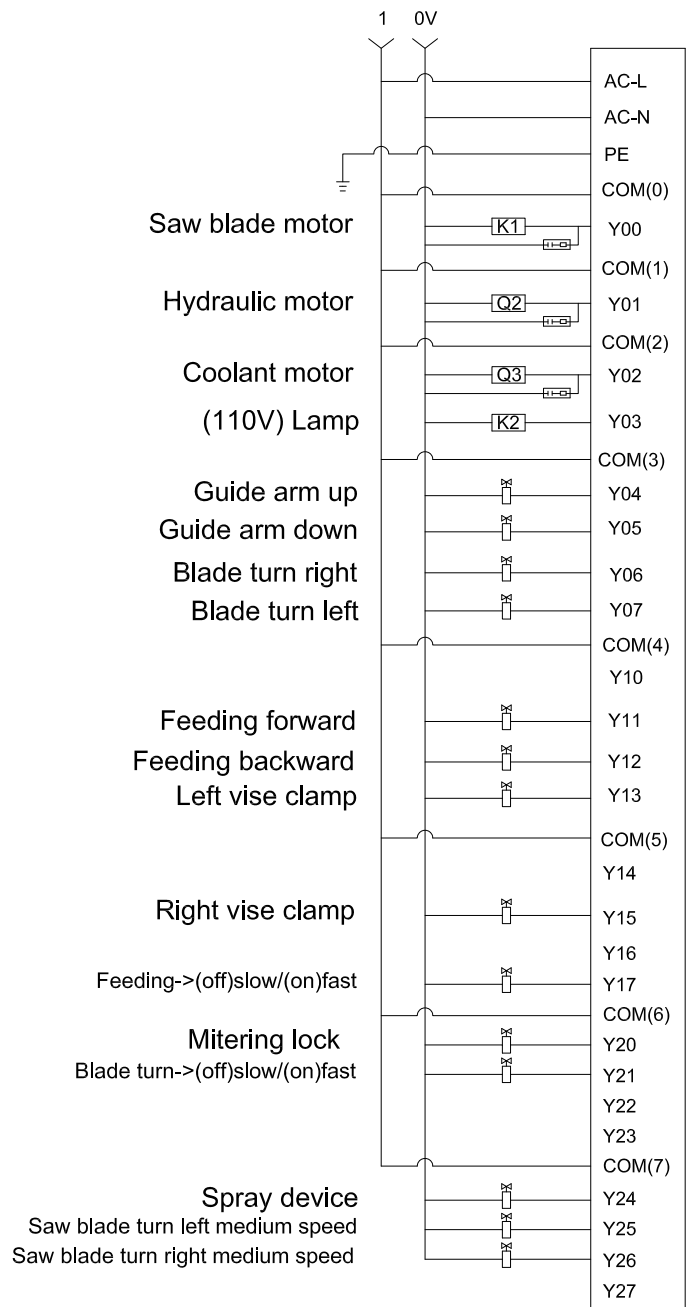
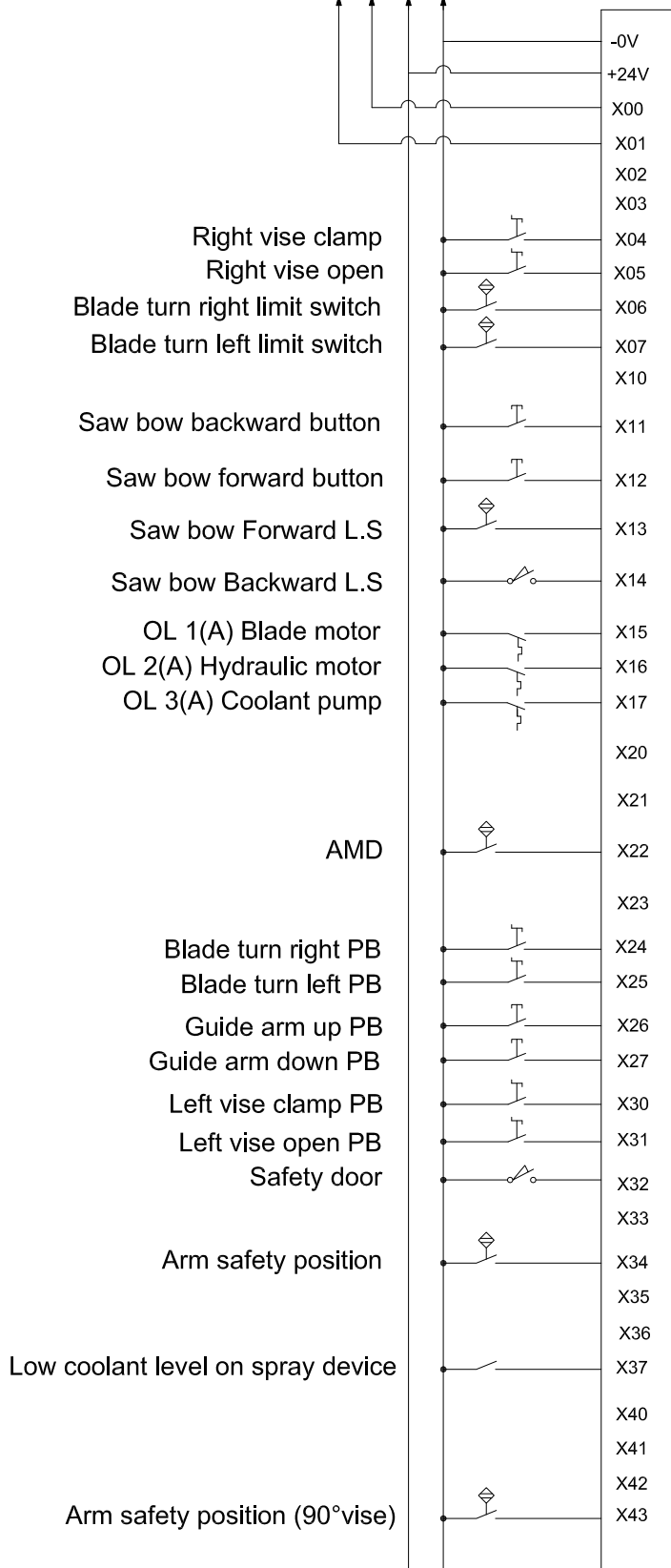

Section 6

HYDRAULIC SYSTEM

HYDRAULIC CIRCUIT DIAGRAMS

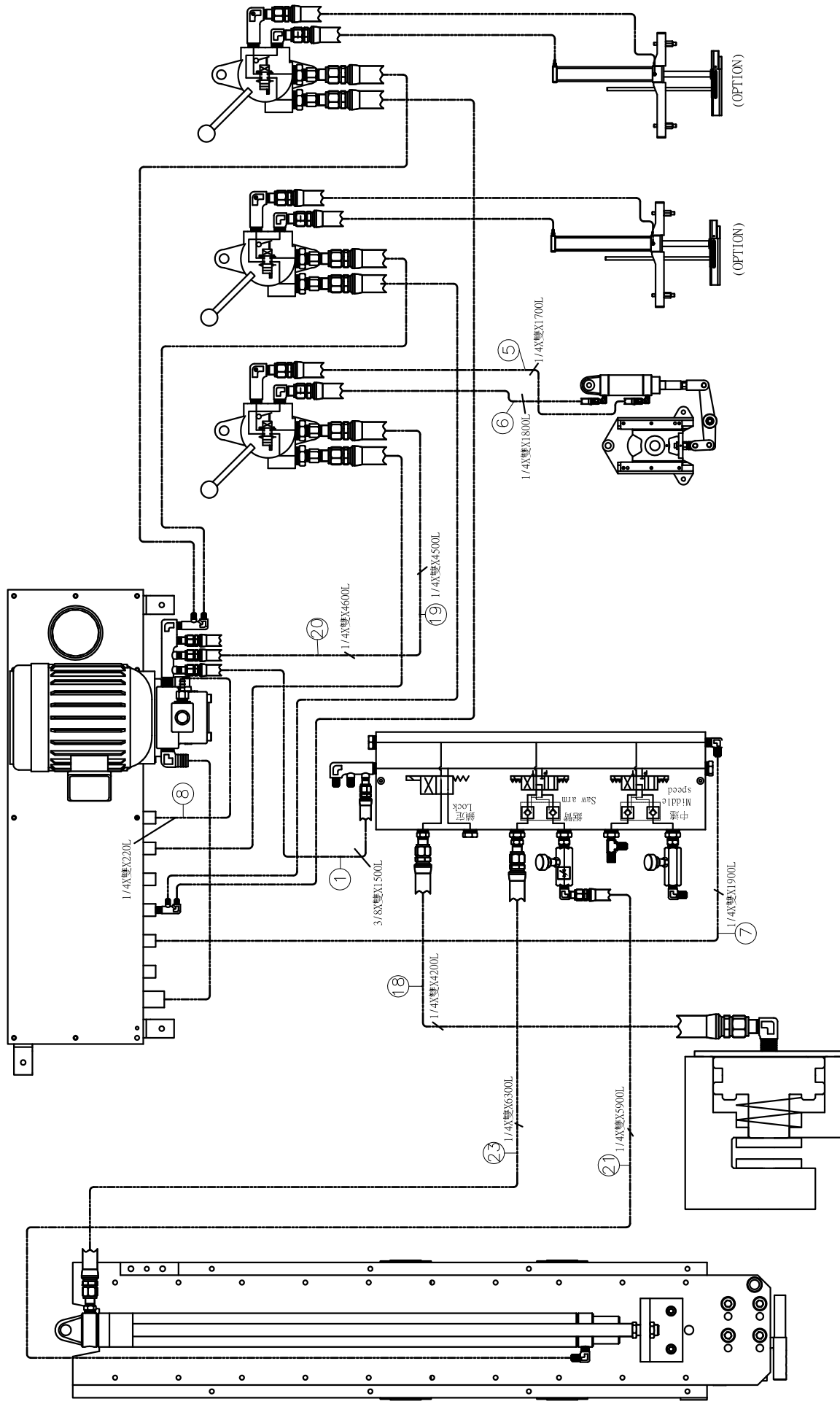

NOTE

DRAW	20161113	陳彥廷	NOTE
CHECK			
APPROVED			
DATE			
NAME			

	COSEN MECHATRONICS CO.,LTD		
	SVC-670DMM / V-2026NC / V-2230NC	HYDRAULIC CIRCUIT (Top clamp assembly)	
DRAWING NO. SNC	HYDRA.DWG	VERSION	1-0

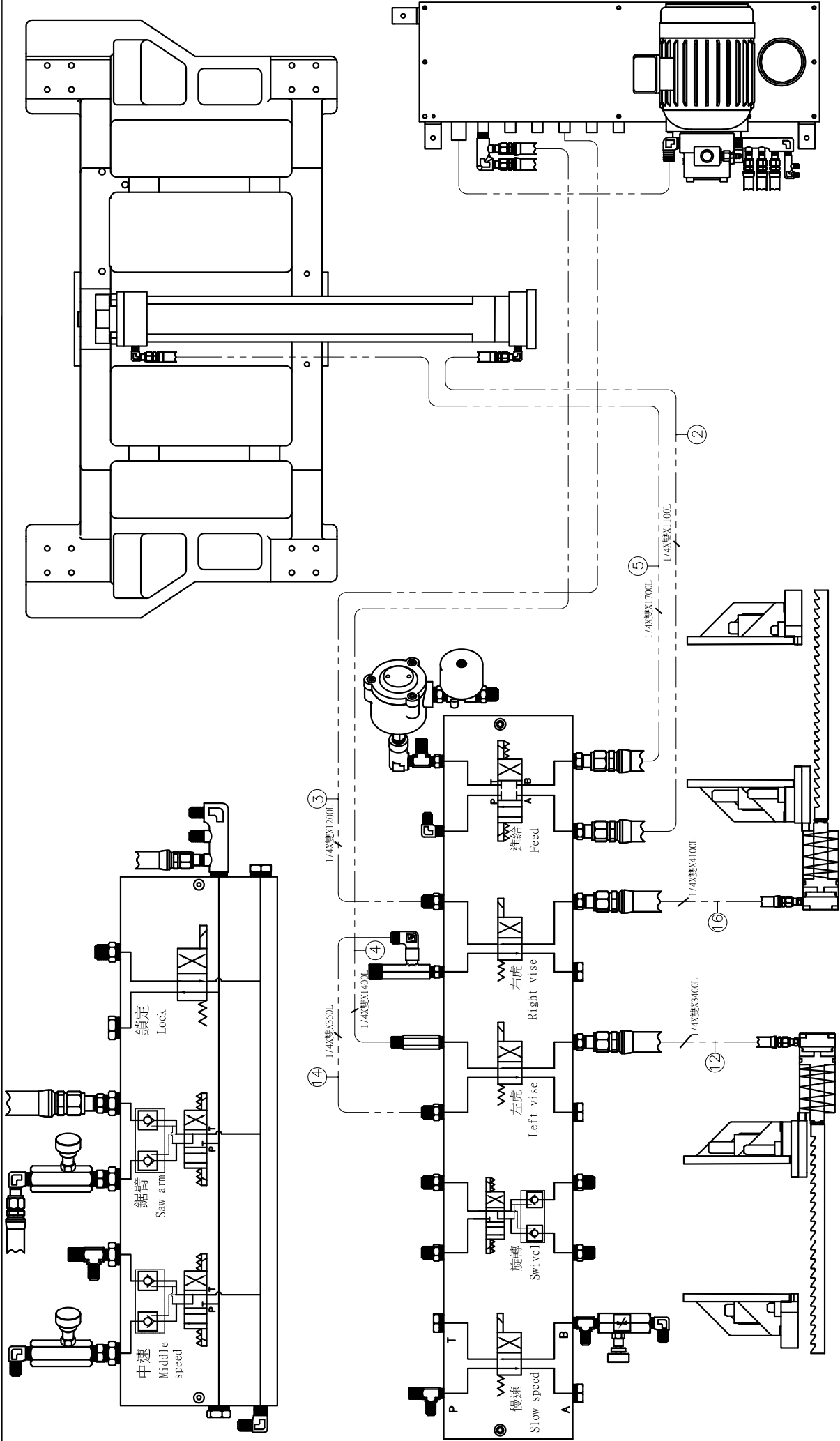

NOTE

DRAWING NO. SNC	HYDRA.DWG VERSION	1-0
	TITLE	SVC-6700MM / V-2026NC / V-2230NC HYDRAULIC CIRCUIT (Top clamp assembly)
DRAW	20161113	陳步廷
	CHECK	
DRAWING NO. SNC	DATE	
	NAME	

COSEN

COSEN MECHATRONICS CO.,LTD
SVC-6700MM / V-2026NC / V-2230NC

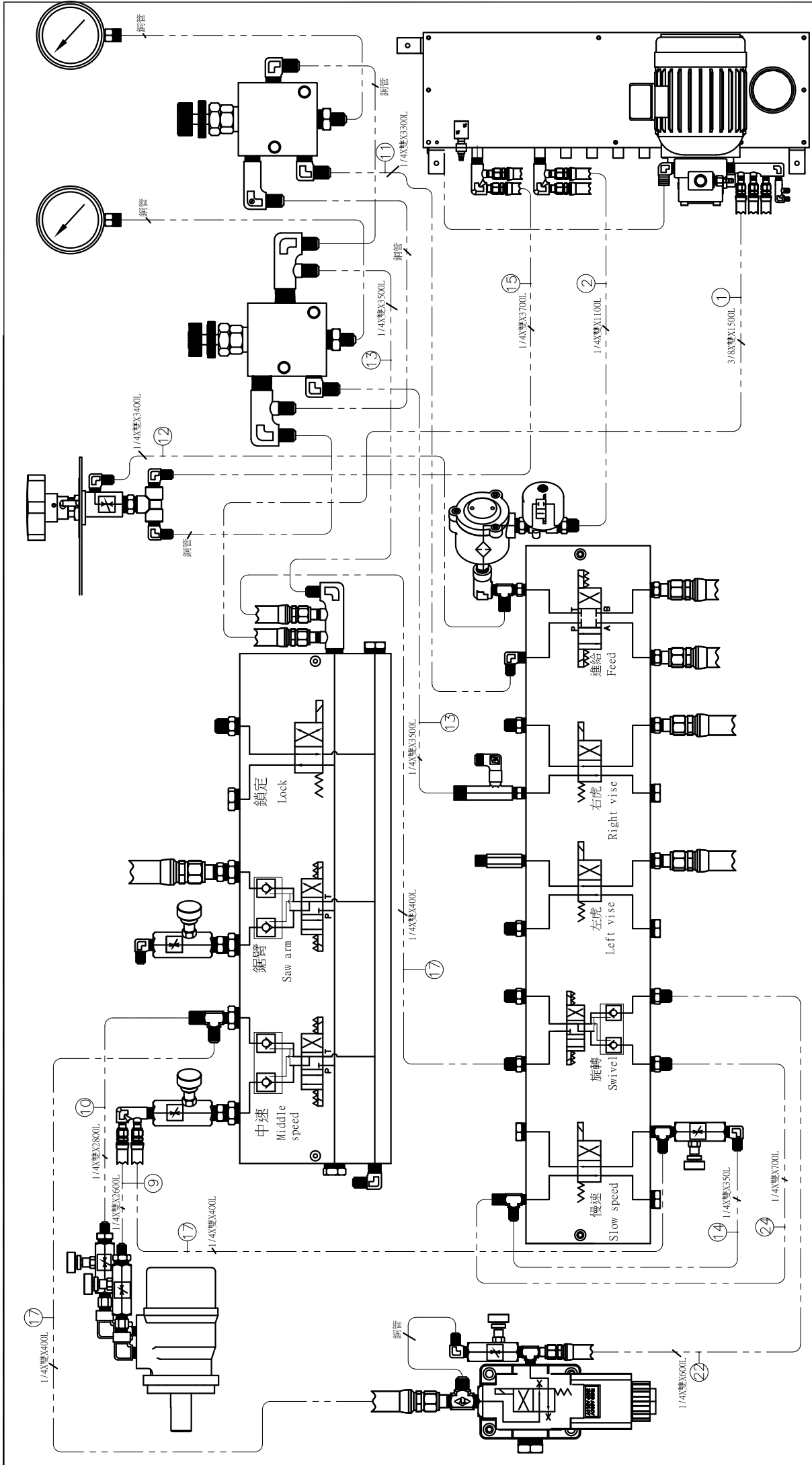

	COSEN MECHATRONICS CO.,LTD		DRAW	20161113	陳步廷	NOTE
	SYC-670DMM / V-2026NC / V-2230NC HYDRAULIC Circuit (Top clamp assembly)		CHECK			
DRAWING NO. SNC		HYDRA.DWG	VERSION	1-0	DATE	NAME

Section 7

BANDSAW CUTTING: A PRACTICAL GUIDE

INTRODUCTION

SAW BLADE SELECTION

WISE LOADING

BladeBreak -In

SOLUTIONS TO SAWING PROBLEMS

INTRODUCTION

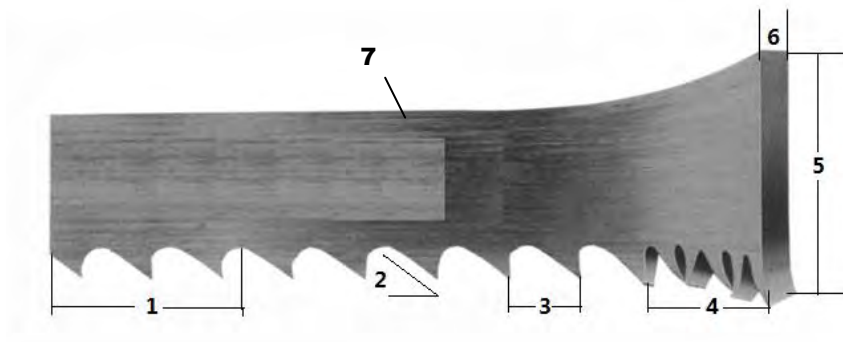

- 1. TPI:** The number of teeth per inch as measured from gullet to gullet.
- 2. Tooth Rake Angle:** The angle of the tooth face measured with respect to a line perpendicular to the cutting direction of the saw.
- 3. Tooth Pitch:** Tooth pitch refers to the number of teeth per inch (tpi). 1 inch equates to 25.4 mm.

A distinction is made between constant tooth pitches with a uniform tooth distance, 2 tpi for example, and variable tooth pitches with different tooth distances within one toothing interval.

Variable tooth pitches, for instance 2-3 tpi, can be characterized by two measures: 2 tpi stands for the maximum tooth distance and 3 tpi stands for the minimum tooth distance in the toothing interval.

Constant



Variable

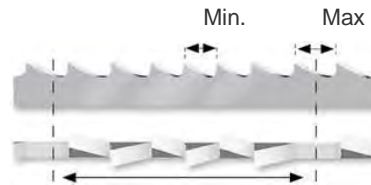

- 4. Set:** The bending of teeth to right or left to allow clearance of the back of the blade through the cut.
- 5. Width:** The nominal dimension of a saw blade as measured from the tip of the tooth to the back of the band.
- 6. Thickness:** The dimension from side to side on the blade.
- 7. Gullet:** The curved area at the base of the tooth. The tooth tip to the bottom of the gullet is the gullet depth.

SAW BLADE SELECTION

1. Band length

The dimensions of the band will depend on the band saw machine that has been installed.

Please refer to Section 2 – General Information

2. Band width

Band width: the wider the band saw blade, the more stability it will have.

3. Cutting edge material

The machinability of the material to be cut determines what cutting material you should choose.

4. Tooth pitch

The main factor here is the contact length of the blade in the workpiece.

If it is 4P, $25.4 \div 4 P = 6.35$ mm, that is, one tooth is 6.35 mm.

If it is 3P, $25.4 \div 3 P = 8.46$ mm If the number is small, it means that the tooth is large.

What is written as 3/4 is that it is a variable pitch of large (3) / small (4).

The saw blade must contact the cutting material at least two pitches. In the case of a thickness of 15 mm, 4P = OK, 3P = NG.

- The surface conditions will also affect the cutting rate. If there are places on the surface on the material which are hard, a slower blade speed will be required or blade damage may result.
- It will be slower to cut tubing than to cut solids, because the blade must enter the material twice, and because coolant will not follow the blade as well.
- Tough or abrasive materials are much harder to cut than their machinability rating would indicate.
- Tooth spacing is determined by the hardness of the material and its thickness in cross section.
- Tooth set prevents the blade from binding in the cut. It may be either a "regular set" (also called a "raker set") or a "wavy set".
- The regular or raker set is most common and consists of a pattern of one tooth to the left, one tooth to the right, and one which is straight, or unset. This type of set is generally used where the material to be cut is uniform in size and for contour cutting.
- Wavy set has groups of teeth set alternately to right and left, forming a wave-like pattern. This reduces the stress on each individual tooth, making it suitable for cutting thin material or a variety of materials where blade changing is impractical. Wavy set is often used where tooth breakage is a problem. This is shown in Fig. 7.2 as follows:

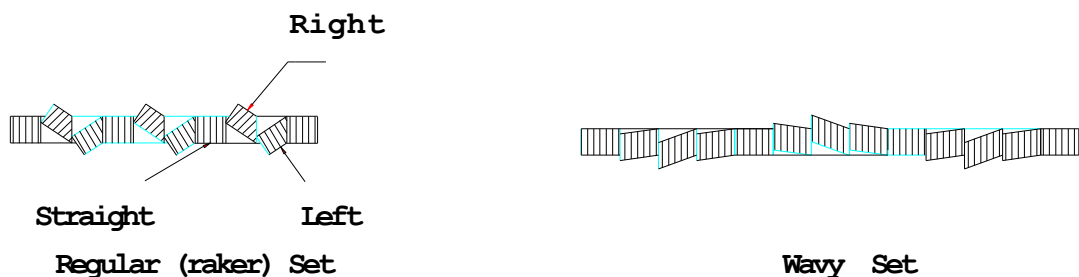

Fig. 7.2 The Saw Set

WISE LOADING

The position in which material is placed in the vise can have a significant impact on the cost per cut.

Often, loading smaller bundles can mean greater sawing efficiency.



When it comes to cutting odd-shaped material, such as angles, I-beams, channel, and tubing, the main point is to arrange the materials in such a way that the blade cuts through as uniform a width as possible throughout the entire distance of cut.

The following diagrams suggest some costeffective ways of loading and fixturing. Be sure, regardless of the arrangement selected, that the work can be firmly secured to avoid damage to the machine or injury to the operator.



BladeBreak -In

Completing a proper break-in on a new band saw blade will dramatically increase its life.

1. Select the proper band speed for the material to be cut.

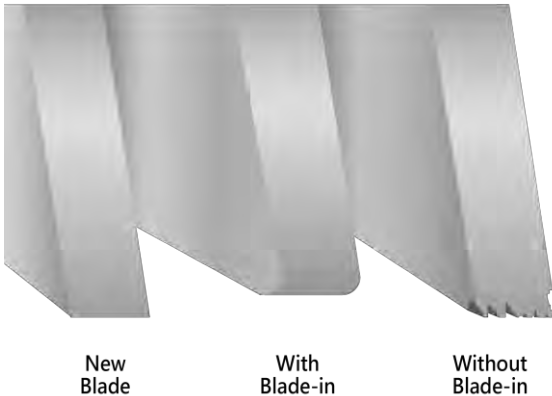

2. Reduce the feed force/rate to achieve a cutting rate 20% to 50% of normal (soft materials require a larger feed rate reduction than harder materials).

3.Begin the first cut at the reduced rate. Make sure the teeth are forming a chip. Small adjustments to the band speed may be made in the event of excessive noise/vibration. During the first cut, **increase feed rate/force** slightly once the blade fully enters the workpiece. With each following cut, **gradually increase feed rate/force** until normal cutting rate is reached.

MAINTENANCE & SERVICE

INTRODUCTION

BASIC MAINTENANCE

MAINTENANCE SCHEDULE

BEFORE BEGINNING A DAY'S WORK

AFTER ENDING A DAY'S WORK

EVERY MONTH

EVERY THREE MONTHS

EVERY SIX MONTHS

STORAGE CONDITIONS

TERMINATING THE USE OF MACHINE

OIL RECOMMENDATION FOR MAINTENANCE

INTRODUCTION

For the best performance and longer life of the band saw machine, a maintenance schedule is necessary. Some of the daily maintenance usually takes just a little time but will give remarkable results for the efficient and proper operation of cutting.

BASIC MAINTENANCE

It is always easy and takes just a little effort to do the basic maintenance. But it always turns out to be a very essential process to assure the long life and efficient operation of the machine. Most of the basic maintenance requires the operator to perform it regularly.

MAINTENANCE SCHEDULE

We suggest you do the maintenance on schedule. The recommended schedule includes three periods,

1. Daily maintenance. 2. Monthly maintenance. 3. Six months maintenance.

Before beginning a day's work

1. Please check the hydraulic oil level. If oil level volume is below 1/2, please add oil as necessary. (Filling up to 2/3 level is better for system operation.)
2. Please check the cutting fluid level, adding fluid as necessary. If the fluid appears contaminated or deteriorated, drain and replace it.
3. Please check the saw blade to ensure that it is properly positioned on both the drive and idle wheels.
4. Please make sure that the saw blade is properly clamped by the left and right inserts.
5. Please check the wire brush for proper contact with the saw blade. Replace the wire brush if it is worn out.

After ending a day's work

Please remove saw chips and clean the machine with discharging the cutting fluid when work has been completed.



Do not discharge cutting fluid while the saw blade is operating because it will cause severe injury on operator's hand.



Be sure the saw blade is fully stop, it will be performed after working inspection.

Every month

Please apply grease to the following points:

1. Idle wheel
2. Drive wheel
3. Blade tension device

Recommended Grease:

- Shell Alvania EP Grease 2
- Mobil Mobilplex 48

Every three months

Replace the transmission oil after operating for three months (or 600 hours).

Recommended Grease:

- Shell Alvania EP Grease 2
- Mobil Mobilplex 48 (600W Cylinder oil)

Every six months

1. Clean the filter of the cutting fluid.
2. Replace the transmission oil for every half of a year (or 1200 hours).
Check the sight gauge to ascertain the transmission level.

Recommended TRANSMISSION OIL

- Omala oil HD220
- Mobil comp 632 600W Cylinder oil

3. Replace the hydraulic oil.

Recommended HYDRAULIC OIL

- Shell Tellus 27
- Mobil DTE OIL light Hydraulic 28

STORAGE CONDITIONS

Generally, this machine will be stored on the following conditions in future:

- (1) Turn off the power.
- (2) Ambient temperature: 5°C ~ 40°C
- (3) Relative humidity: 30%~95% (without condensation)
- (4) Atmosphere: use a plastic canvas to cover machine to avoid excessive dust, acid fume, corrosive gases and salt.
- (5) Avoid exposing to direct sunlight or heat rays which can change the environmental temperature.
- (6) Avoid exposing to abnormal vibration.
- (7) Must be connected to earth.

TERMINATING THE USE OF THE MACHINE

Waste disposal:

When your machine can not work anymore, you should leak out the oil from machine body. Please storage the oil in safe place with bottom. Ask a environment specialist to handle the oil. It can avoid soil pollution. The oil list in machine:

- Hydraulic oil
- Cutting fluid
- Drive wheel gear oil

OIL RECOMMENDATION FOR MAINTENANCE

Item	Method	Revolution	Suggest oil
Dovetail guide	Keep grease covered. Antirust.	Daily	Shell R2
Roller bearing	Sweep clean and oil with lubricant.	Daily	SEA #10
Bed roller / surface	Sweep clean and oil with lubricant.	Daily	SEA #10
Nipples of bearing	Use grease gun, but not excess.	Monthly	Shell R2
Blade tension device	Use grease gun, but not excess.	Monthly	Shell R2
Reducer	Inspect once a week. Change oil of 600 hours of using. Change it every year.	Regularly	Omala oil HD220 Mobil Gear 630
Hydraulic system	Inspect half a year. Change oil every year.	Regularly	Shell Tellus 32 Mobil DTE oil Light Hydraulic 24
Bearing	Inserts	Oil with lubricant, but not excess.	Daily
	Band wheel	Oil with lubricant, but not excess.	Weekly
	Cylinder	Oil with lubricant, but not excess.	6 Monthly
	Wire brush	Oil with lubricant, but not excess.	6 Monthly



- 1. Turn off the stop circuit breaker switch before servicing the machine.**
- 2. Then post a sign to inform people that the machine is under maintenance.**
- 3. Drain all of the cutting fluid and oil off and carefully treat them to avoid pollution.**

TROUBLESHOOTING

INTRODUCTION

PRECAUTIONS

GENERAL TROUBLES & SOLUTIONS

MINOR TROUBLES & SOLUTIONS

MOTOR TROUBLES & SOLUTIONS

BLADE TROUBLES & SOLUTIONS

SAWING PROBLEMS & SOLUTIONS

RE-ADJUSTING THE ROLLER TABLE

INTRODUCTION

All the machines manufactured by us pass a 48 hours continuously running test before shipping out and we are responsible for the after sales service problems during the warranty period if the machines are used normally. However, there still exist the some unpredictable problems which may disable the machine from operating.

Generally speaking, the system troubles in this machine model can be classified into three types, namely GENERAL TROUBLES, MOTOR TROUBLES and BLADE TROUBLES. Although you may have other troubles which can not be recognized in advance, such as malfunctions due to the limited life-span of mechanical, electric or hydraulic parts of the machine.

We have accumulated enough experiences and technical data to handle all of the regular system troubles. Meanwhile, our engineering department had been continuously improving the machines to prevent all possible troubles.

It is hoped that you will give us your maintenance experience and ideas so that both sides can achieve the best performance.

PRECAUTIONS

When an abnormality occurs in the machine during operation, you can do it yourself safely. If you have to stop machine motion immediately for parts exchanging, you should do so according to the following procedures:

- Press HYDRAULIC MOTOR OFF button or EMERGENCY STOP button.
- Open the electrical enclosure door.
- Turn off breaker.



BEFORE ANY ADJUSTMENT OR MAINTENANCE OF THE MACHINE, PLEASE MAKE SURE TO TURN OFF THE MACHINE AND DISCONNECT THE POWER SUPPLY.

GENERAL TROUBLES AND SOLUTIONS



DISCONNECT POWER CORD TO MOTOR BEFORE ATTEMPTING ANY REPAIR OR INSPECTION.

TROUBLE	PROBABLE CAUSE	SUGGESTED REMEDY
Motor stalls	Excessive belt tension	Adjust belt tension so that belt does not slip on drive pulley while cutting (1/2" Min. deflection of belt under moderate pressure.)
	Excessive head pressure	Reduce head pressure. Refer to Operating Instructions "Adjusting Feed".
	Excessive blade speed	Refer to Operating Instructions "Speed Selection".
	Improper blade selection	Refer to Operating Instructions "Blade Selection".
Cannot make square cut	Dull blade	Replace blade.
	Guide rollers not adjusted properly	Refer to Adjustments.
	Rear vise jaw not adjusted properly	Set fixed vise jaw 90° to blade.
	Excessive head pressure	Reduce head pressure. Refer to operating instructions "Adjusting Feed."
Increased cutting time	Dull blade	Replace blade
	Insufficient head pressure	Increase head pressure. Refer to Operating Instructions "Adjusting Feed."
	Reduce blade speed	Refer to Operating Instructions "Speed Selection."
Will not cut	Motor running in wrong direction	Reverse rotation of motor. (Motor rotation C.C.W. pulley end.)
	Blade teeth pointing in wrong direction	Remove blade, turn blade inside out. Re-install blade. (Teeth must point in direction of travel.)
	Hardened material	Use special alloy blades. (Consult your industrial distributor for recommendation on type of blade required.)

MINOR TROUBLES & SOLUTIONS

TROUBLE	PROBABLE CAUSE	SUGGESTED REMEDY
Saw blade motor does not run even though blade drive button is pressed.	Overload relay activated	Reset
	Saw blade is not at forward limit position.	Press SAW FRAME FORWARD button

MOTOR TROUBLES & SOLUTIONS

TROUBLE	PROBABLE CAUSE	SUGGESTED REMEDY
Motor will not start	Magnetic switch open, or protector open.	Reset protector by pushing red button (inside electric box.)
	Low voltage	Check power line for proper voltage.
	Open circuit in motor or loose connections.	Inspect all lead terminations on motor for loose or open connections.
Motor will not start, fuse or circuit breakers "blow".	Short circuit in line, cord or plug.	Inspect line, cord and plug for damaged insulation and shorted wire.
	Short circuit in motor or loose connections	Inspect all lead terminations on motor for loose or shorted terminals or worn insulation on wires.
	Incorrect fuses or circuit breakers in power line.	Install correct fuses or circuit breakers.
Motor fail to develop full power. (Power output of motor decreases rapidly with decrease in voltage at motor terminals.)	Power line overloaded with lights, appliances and other motors.	Reduce the load on the power line.
	Undersize wires or circuit too long.	Increase wire sizes, or reduce length of wiring
	General overloading of power company's facilities.	Request a voltage check from the power company
Motor overheat	Motor overloaded.	Reduce load on motor
	Air circulation through the motor restricted.	Clean out motor to provide normal air circulation through motor.
Motor stalls (Resulting in blown fuses or tripped circuit breakers)	Short circuit in motor or loose connections.	Inspect terminals in motor for loose or shorted terminals or worn insulation on lead wires.
	Low voltage	Correct the low line voltage conditions.
	Incorrect fuses or circuit breakers in power line.	Install correct fuses circuit breakers.
	Motor overloaded	Reduce motor load.
Frequent opening of fuses or circuit breakers.	Motor overloaded	Reduce motor load
	Incorrect fuses or circuit breakers.	Install correct fuses or circuit breakers.

BLADE TROUBLES AND SOLUTIONS



DISCONNECT POWER CORD TO MOTOR BEFORE ATTEMPTING ANY REPAIR OR INSPECTION.

TROUBLE	PROBABLE CAUSE	SUGGESTED REMEDY
Teeth strippage	Too few teeth per inch	Use finer tooth blade
	Loading of gullets	Use coarse tooth blade or cutting lubricant.
	Excessive feed	Decrease feed
	Work not secured in vise	Clamp material securely
Blade breakage	Teeth too coarse	Use a finer tooth blade
	Misalignment of guides	Adjust saw guides
	Dry cutting	Use cutting lubricant
	Excessive speed	Lower speed. See Operating Instructions "Speed selection."
	Excessive speed	Reduce feed pressure. Refer to Operating Instructions "Adjusting Feed."
	Excessive tension	Tension blade to prevent slippage on drive wheel while cutting.
Blade line Run-out or Run-in	Wheels out of line	Adjust wheels
	Guides out of line	For a straight and true cut, realign guides, check bearings for wear.
	Excessive pressure	Conservative pressure assures long blade life and clean straight cuts.
	Support of blade insufficient	Move saw guides as close to work as possible.
	Material not properly secured in vise	Clamp material in vise, level and securely.
Blade twisting	Blade tension improper	Loosen or tighten tension on blade.
	Blade not in line with guide bearings	Check bearings for wear and alignment.
	Excessive blade pressure	Decrease pressure and blade tension
Premature tooth wear	Blade binding in cut	Decrease feed pressure
	Dry cutting	Use lubricant on all materials, except cast iron
	Blade too coarse	Use finer tooth blade
	Not enough feed	Increase feed so that blade does not ride in cut
	Excessive speed	Decrease speed

SAWING PROBLEMS AND SOLUTIONS

Other than this manual, the manufacturer also provides some related technical documents listed as follows:

Sawing Problems and Solutions

					Vibration during cutting	Failure to cut	Short life of saw blade	Curved cutting	Broken blade		
✓	✓	✓	✓	✓						Use of blade with incorrect pitch	Use blade with correct pitch suited to workpiece width
✓	✓	✓	✓	✓						Failure to break-in saw blade	Perform break-in operation
✓	✓	✓								Excessive saw blade speed	Reduce speed
			✓	✓						Insufficient saw blade speed	Increase speed
✓		✓	✓	✓						Excessive saw head descending speed	Reduce speed
✓		✓	✓							Insufficient saw head descending speed	Increase speed
		✓	✓							Insufficient saw blade tension	Increase tension
✓		✓	✓	✓						Wire brush improperly positioned	Relocate
✓		✓	✓							Blade improperly clamped by insert	Check and correct
✓	✓	✓	✓	✓						Improperly clamped workpiece	Check and correct
	✓	✓	✓							Excessively hard material surface	Soften material surface
		✓	✓	✓						Excessive cutting rate	Reduce cutting rate
	✓	✓								Non-annealed workpiece	Replace with suitable workpiece
✓		✓	✓	✓						Insufficient or lean cutting fluid	Add fluid or replace
✓		✓	✓	✓						Vibration near machine	Relocate machine
		✓	✓							Non-water soluble cutting fluid used	Replace
✓		✓	✓							Air in cylinder	Bleed air
✓		✓		✓						Broken back-up roller	Replace
✓	✓	✓	✓	✓						Use of non-specified saw blade	Replace
✓	✓	✓	✓	✓						Fluctuation of line voltage	Stabilize
✓		✓	✓							Adjustable blade guide too far from workpiece	Bring blade guide close to workpiece
✓		✓	✓	✓						Loose blade guide	Tighten
		✓		✓						Blue or purple saw chips	Reduce cutting rate
✓		✓		✓						Accumulation of chips at inserts	Clean
	✓									Reverse positioning of blade on machine	Reinstall
✓		✓	✓							Workpieces are not bundled properly	Re-bundle
✓		✓		✓						Back edge of blade touching wheel flange	Adjust wheel to obtain clearance
✓	✓	✓								Workpiece of insufficient diameter	Use other machine, suited for diameter of workpiece
	✓	✓	✓							Saw blade teeth worn	Replace

SOLUTIONS TO SAWING PROBLEMS

Table Of Contents

#1. Heavy Even Wear On Tips and Corners Of Teeth	#11. Uneven Wear Or Scoring On The Sides Of Band
#2. Wear On Both Sides Of Teeth	#12. Heavy Wear And/Or Swagging On Back Edge
#3. Wear On One Side Of Teeth	#13. Butt Weld Breakage
#4. Chipped Or Broken Teeth	#14. Heavy Wear In Only The Smallest Gullets
#5. Body Breakage Or Cracks From Back Edge	#15. Body Breaking – Fracture Traveling In An Angular Direction
#6. Tooth Strippage	#16. Body Breakage Or Cracks From Gullets
#7. Chips Welded To Tooth Tips	#17. Band is Twisted Into A Figure "8" Configuration
#8. Gullets Loading Up With Material	#18. Used Band Is "Long" On The Tooth Edge
#9. Discolored Tips Of Teeth Due To Excessive Frictional Heat	#19. Used Band Is "Short" On The Tooth Edge
#10. Heavy Wear On Both Sides Of Band	#20. Broken Band Shows A Twist In Band Length.

#1. Heavy Even Wear On Tips and Corners Of Teeth



Probable Cause :

- A.** Improper break-in procedure.
- B.** Excessive band speed for the type of material being cut. This generates a high tooth tip temperature resulting in accelerated tooth wear.
- C.** Low feed rate causes teeth to rub instead of penetrate. This is most common on work hardened materials such as stainless and toolsteels.
- D.** Hard materials being cut such as "Flame Cut Edge" or abrasive materials such as " Fiber Reinforced Composites".
- E.** Insufficient sawing fluid due to inadequate supply, improper ratio, and/or improper application

#2. Wear On Both Sides Of Teeth



Probable Cause :

- A. Broken, worn or missing back-up guides allowing teeth to contact side guides.
- B. Improper side guides for band width.
- C. Backing the band out of an incomplete cut.

#3. Wear On One Side Of Teeth

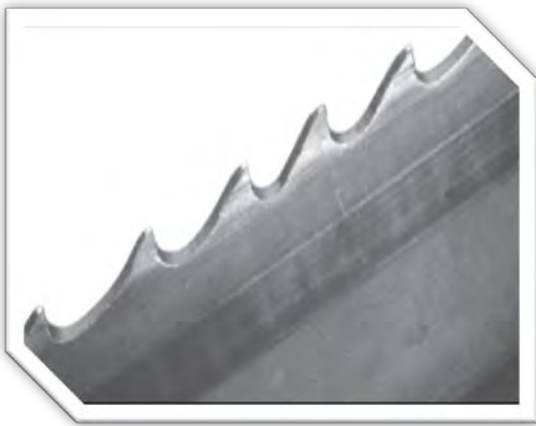

Probable Cause :

- A. Worn wheel flange, allowing side of teeth to contact wheel surface or improper tracking on flangeless wheel.
- B. Loose or improperly positioned side guides.
- C. Blade not perpendicular to cut.
- D. Blade rubbing against cut surface on return stroke of machine head.
- E. The teeth rubbing against a part of machine such as chip brush assembly, guards, etc.

#4. Chipped Or Broken Teeth



Probable Cause :

- A. Improper break-in procedure.
- B. Improper blade selection for application.
- C. Handling damage due to improper opening of folded band.
- D. Improper positioning or clamping of material.
- E. Excessive feeding rate or feed pressure.
- F. Hitting hard spots or hard scale in material

#5. Body Breakage Or Cracks From Back Edge

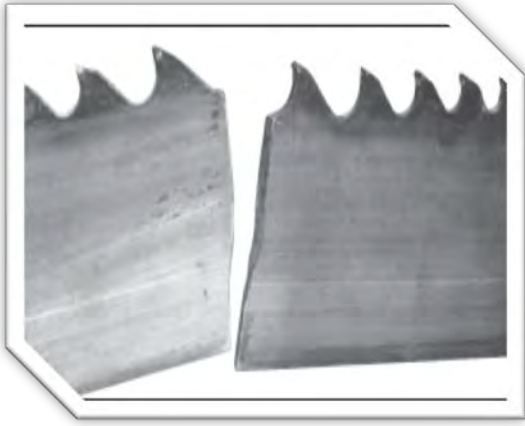

Probable Cause :

- A. Excessive back-up guide "preload" will cause back edge to work harden which results in cracking.
- B. Excessive feed rate.
- C. Improper band tracking – back edge rubbing heavy on wheel flange.
- D. Worn or defective back-up guides.
- E. Improper band tension.
- F. Notches in back edge from handling damage

#6. Tooth Strippage



Probable Cause :

- A. Improper or lack of break-in procedure.
- B. Worn, missing or improperly positioned chip brush.
- C. Excessive feeding rate or feed pressure.
- D. Movement or vibration of material being cut.
- E. Improper tooth pitch for cross sectional size of material being cut.
- F. Improper positioning of material being cut.
- G. Insufficient sawing fluid due to inadequate supply, improper ratio and/or improper application.
- H. Hard spots in material being cut.
- I. Band speed too slow for grade of material being cut.

#7. Chips Welded To Tooth Tips



Probable Cause :

- A. Insufficient sawing fluid due to inadequate supply, improper ratio and/or improper application.
- B. Worn, missing or improperly positioned chip brush.
- C. Improper band speed.
- D. Improper feeding rate.

#8. Gullets Loading Up With Material



Probable Cause :

- A. Too fine of a tooth pitch – insufficient gullet capacity.
- B. Excessive feeding rate producing too large of a chip.
- C. Worn, missing or improperly positioned chip brush.
- D. Insufficient sawing fluid due to inadequate supply, improper ratio and/or improper application.

#9. Discolored Tips Of Teeth Due To Excessive Frictional Heat



Probable Cause :

- A. Insufficient sawing fluid due to inadequate supply, improper ratio and/or improper application.
- B. Excessive band speed.
- C. Improper feeding rate.
- D. Band installed backwards.

10. Heavy Wear On Both Sides Of Band

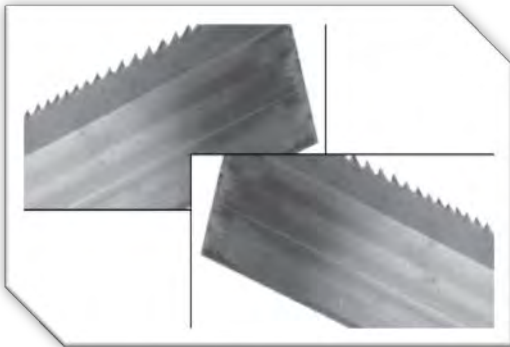

Probable Cause :

- A. Chipped or broken side guides.
- B. Side guide adjustment may be too tight.
- C. Insufficient flow of sawing fluid through the side guides.
- D. Insufficient sawing fluid due to inadequate supply, improper ratio and/or improper application.

#11. Uneven Wear Or Scoring On The Sides Of Band

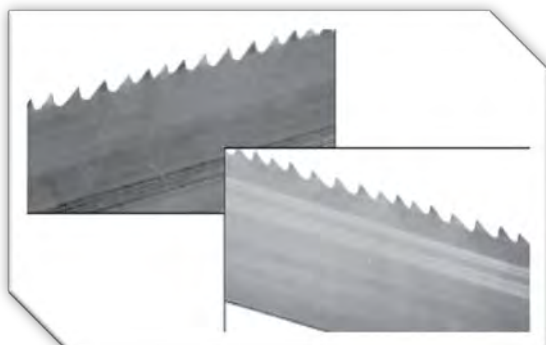

Probable Cause :

- A. Loose side guides.
- B. Chipped, worn or defective side guides.
- C. Band is rubbing on part of the machine.
- D. Guide arms spread to maximum capacity.
- E. Accumulation of chips in side guides.

#12. Heavy Wear And/Or Swagging On Back Edge



Probable Cause :

- A. Excessive feed rate.
- B. Excessive back-up guide "preload".
- C. Improper band tracking – back edge rubbing heavy on wheel flange.
- D. Worn or defective back-up guides.

#13. Butt Weld Breakage



Probable Cause :

- A. Any of the factors that cause body breaks can also cause butt weld breaks.
- (See Observations #5, #15 and #16)**

#14. Heavy Wear In Only The Smallest Gullets



Probable Cause :

- A. Excessive feeding rate.
- B. Too slow of band speed.
- C. Using too fine of a tooth pitch for the size of material being cut.

#15. Body Breaking – Fracture Traveling In An Angular Direction



Probable Cause :

- A. An excessive twist type of stress existed.
- B. Guide arms spread to capacity causing excessive twist from band wheel to guides.
- C. Guide arms spread too wide while cutting small cross sections.
- D. Excessive back-up guide "preload".

#16. Body Breakage Or Cracks From Gullets

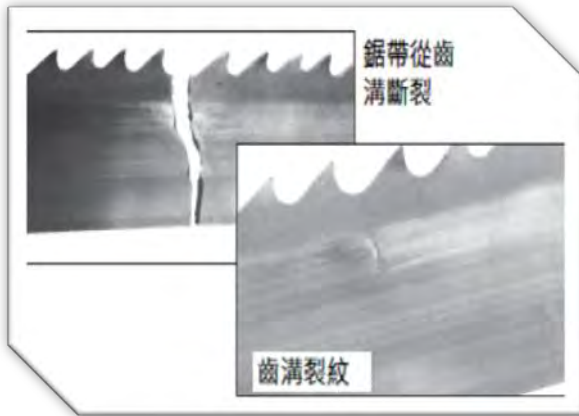

Probable Cause :

- A. Excessive back-up guide "preload".
- B. Improper band tension.
- C. Guide arms spread to maximum capacity.
- D. Improper beam bar alignment.
- E. Side guide adjustment is too tight.
- F. Excessively worn teeth.

#17. Band is Twisted Into A Figure "8" Configuration

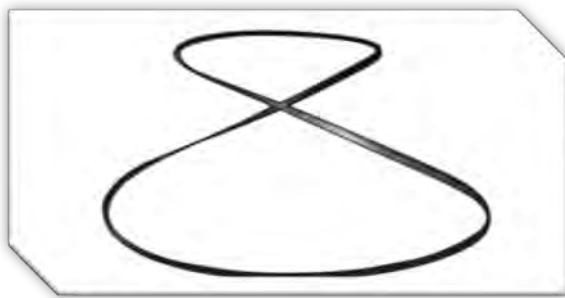

Probable Cause :

- A. Excessive band tension.
- B. Any of the band conditions which cause the band to be long (#18) or short (#19) on tooth edge.
- C. Cutting a tight radius.

#18. Used Band Is "Long" On The Tooth Edge



Probable Cause :

- A. Side guides are too tight – rubbing near gullets.
- B. Excessive "preload" – band riding heavily against back-up guides.
- C. Worn band wheels causing uneven tension.
- D. Excessive feeding rate.
- E. Guide arms are spread to maximum capacity.
- F. Improper band tracking – back edge rubbing heavy on wheel flange.

#19. Used Band Is "Short" On The Tooth Edge



Probable Cause :

- A. Side guides are too tight – rubbing near back edge.
- B. Worn band wheels causing uneven tension.
- C. Guide arms are spread too far apart.
- D. Excessive feeding rate.

#20. Broken Band Shows A Twist In Band Length



Probable Cause :

- A. Excessive band tension
- B. Any of the band conditions which cause the band to be long (#18) or short (#19) on tooth edge.
- C. Cutting a tight radius.

RE-ADJUSTING THE ROLLER TABLE

If the feeding table suffers the huge stroke and the alignment is effected, follow the below procedure to adjust.

TOOL, measuring

Measurement, Horizontal balance

Procedure

1. Screw or loosen the adjusting bolt to attain the horizontal balance (leveling) between the roller table and the machine frame.
2. Ensure that the machine frame is not struck by the loaded material on the feeding table.
3. Check the leveling by the measuring tool.
4. After finished the adjusting, fix the roller table.



If the feeding table and the machine frame are not positioned under the horizontal balance, the loaded material may be going up gradually and affect the cutting effect.

Warranty

Warranty

New machines are warranted to be free from defects in workmanship and material for a period of one (1) year from the date of shipment by Seller. The warranty period is based on normal usage of two thousand eighty hours (2080) per year and is reduced proportionately for any excess usage. Products, which under normal operating conditions in Buyer's plant are defective in workmanship or material, will be repaired or replaced at the option of Seller.

This warranty does not cover shipping freight charges for either the return of the defective part or for the shipping of the replacement or repaired part.

Seller will have no obligation to repair or replace perishable parts, or materials or parts damaged by misuse, negligence or failure of Buyer to provide appropriate maintenance and service as stated in the operator's manual or industry standard and normally acceptable practices.

This warranty does not apply if the machine has been altered or modified without our prior written consent.

In the case of components or units purchased by Seller including work holding devices, tool holders, motors and controls, the warranty shall not exceed that received by Seller from the supplier of such components or units.

Seller will not assume responsibility for products or components returned to Seller without prior consent or for unauthorized repairs to its products, even though defective.

Electrical Equipment: The warranty available for all electrical components to the Buyer will be voided if the voltage supplied to the machine is found to be outside the stated voltage of the machine by +/- 10% and/or grounded at machine.

Accessories Supplied with Manufacturer's Equipment: The warranties available to the Buyer are those extended by the accessory manufacturer, if any, to the extent they are in force and effect. The ACCESSORY MANUFACTURER'S WARRANTY, if any, is exclusive and is in lieu of all other warranties whether written, oral or implied.

PARTS

SPARE PARTS RECOMMENDATIONS

PART LIST

SPARE PARTS RECOMMENDATIONS

The following table lists the common spare parts we suggest you purchase in advance:

Part Name	Part Name
Saw blade	Coolant tank filter
Wire brush	Steel plates
Carbide inserts	Rollers
Bearings	Coolant pump
Hydraulic tank leak-proof asbestos	Belt
Rubber washer	Duster seal
Gear reducer	Oil seal
O-ring	Snap ring
Drive wheel	Idle wheel

總組合 TOTAL ASSEMBLY

PP-32117-CE - COOLANT
PUMP S/N 109CM00041 as
per Shaun 12/2/2021

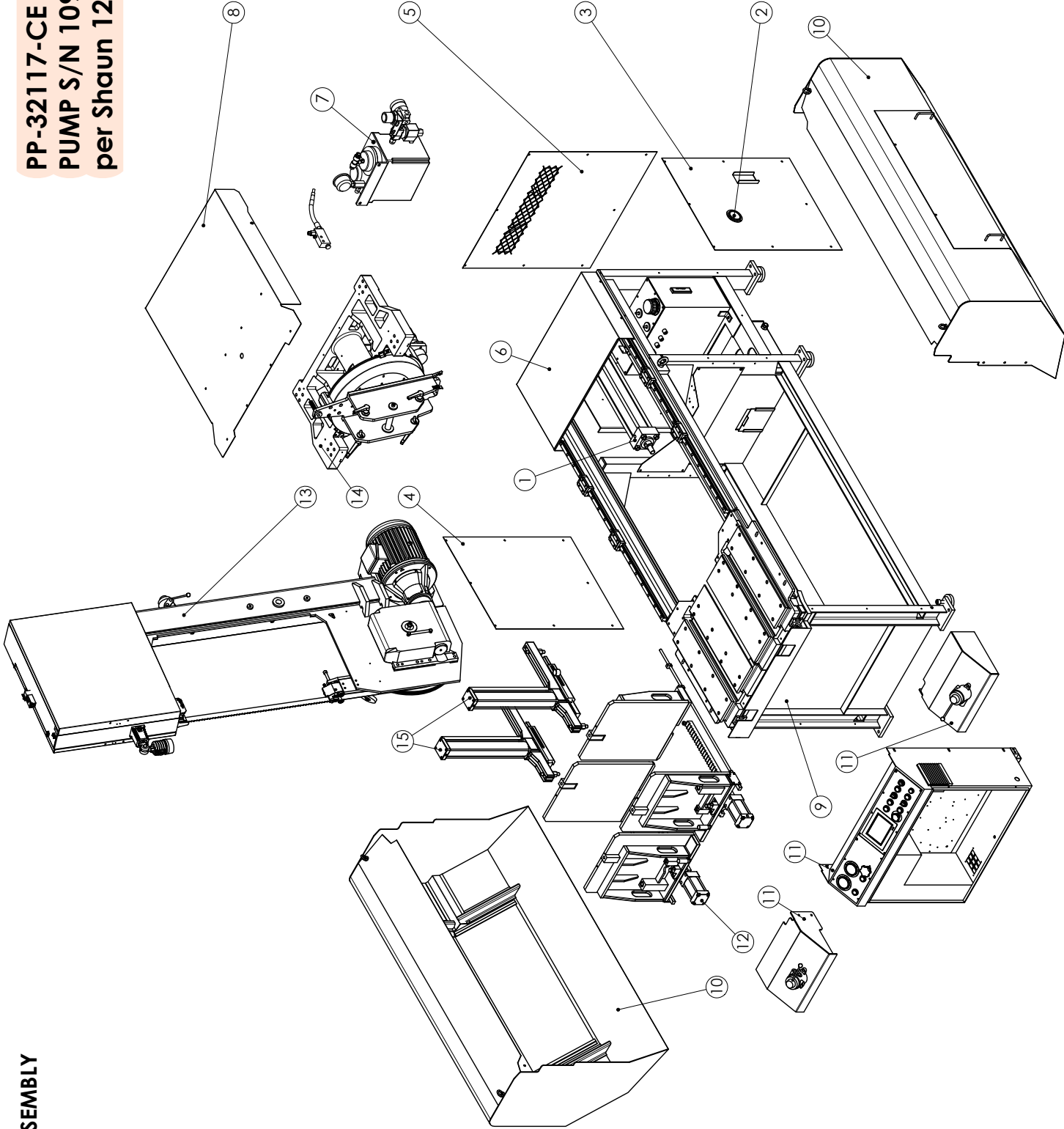



V-2026NC

2015/10/15

總組合 TOTAL ASSEMBLY

ITEM	PART NO.	PART NAME	PART NAME IN CHINESE	PART SPEC.	QTY
1	HFB80L605E35	hydraulic cylinder	油壓缸		1
2	PP-43315	Built-in pressure gauge	油錶		1
3	VC670D-1059	right rear cover	右後蓋		1
4	VC670D-1061	left rear cover	左後蓋		1
5	VC670D-1071	rear cover	後蓋		1
6	VC670D-2014	rear cover (1)	後護蓋(一)		1
7	PP-35010A-1	pneumatic oil injector	油霧式幫浦組		1
8	VC600D-2016	rear cover 2 assembly	後護蓋(二)組		1
9	VC670D-10000	base assembly	底座組		1
10	VC670D-10600	base cover assembly	底座護蓋組		2
11	VC670D-13000	electrical compartment assembly	電控箱組		1
12	VC670D-20000	bed and vise assembly	床面虎鉗組		1
13	VC670D-30000	saw bow assembly	鋸弓組		1
14	VC670D-34500	saw bow rotating assembly	鋸弓滑軌組		1
15	VC600D-41000	Top clamp assembly	下壓組		2

後護蓋組

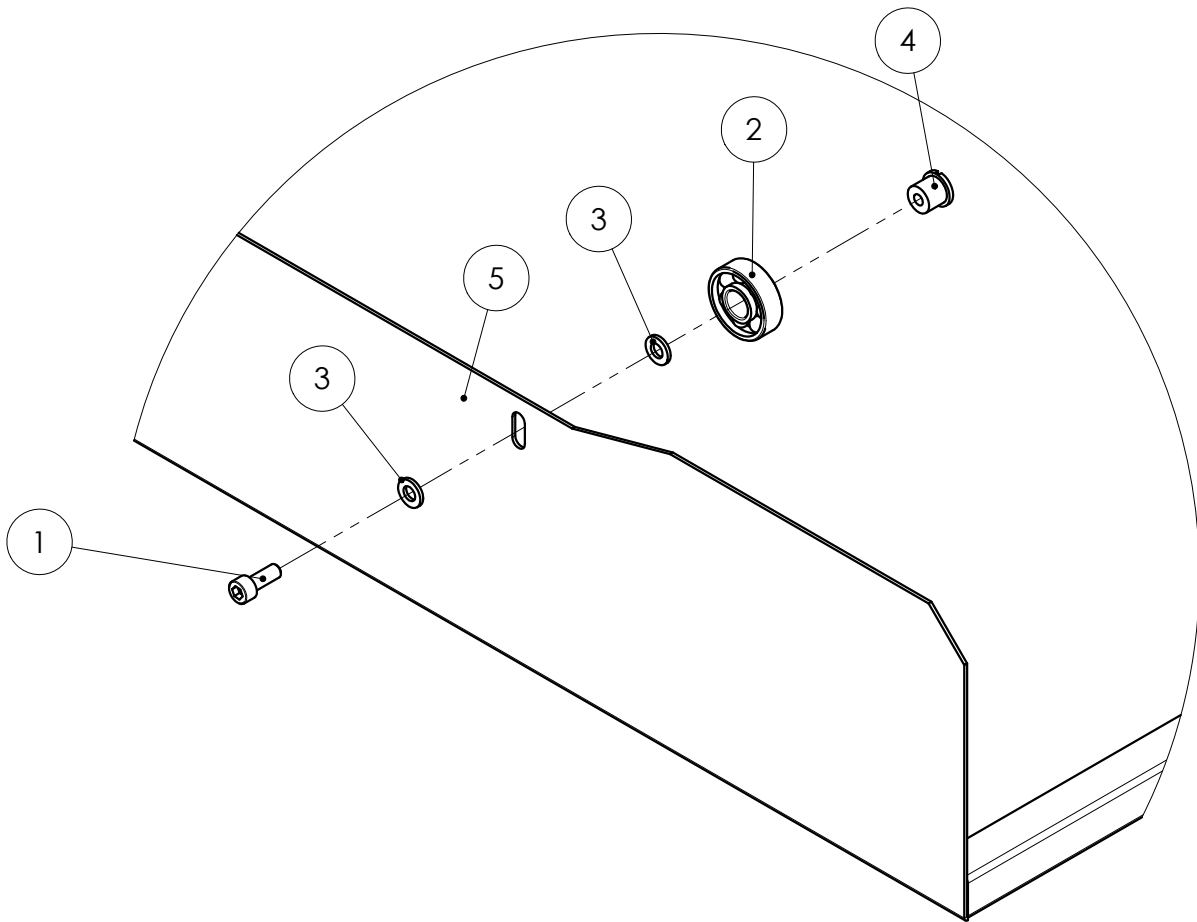
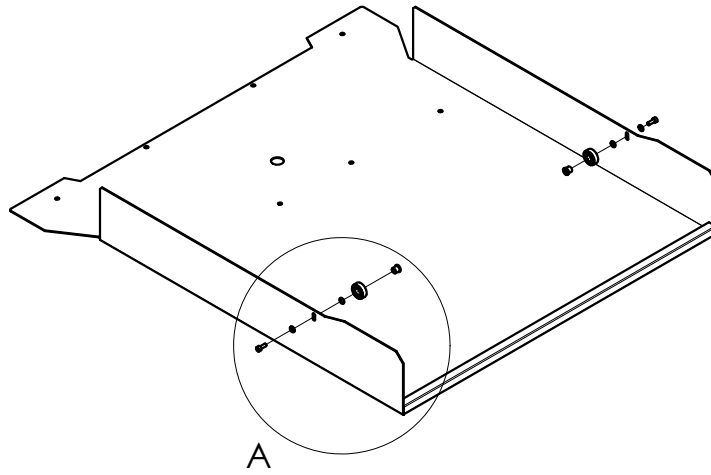

細部放大圖 A
比例 1:3



SVC-670DMM / SVC-670DMC / MVC-670DM / V-2026NC

2015/7/15

後護蓋組 REAR COVER ASSEMBLY

ITEM	PART NO.	PART NAME	PART NAME IN CHINESE	PART SPEC.	QTY
1	PBA-6-15	Hex soc cap screw	內六角螺絲		2
2	PP-14271	bearing	軸承		2
3	PPA-8	flat washer	平面華司		2
4	VC600D-1480	Bearing fixed seat	軸承固定座		2
5	VC600D-2016	Rear cover (2)	後護蓋(二)		1

VC600D-21000 譯碼器組

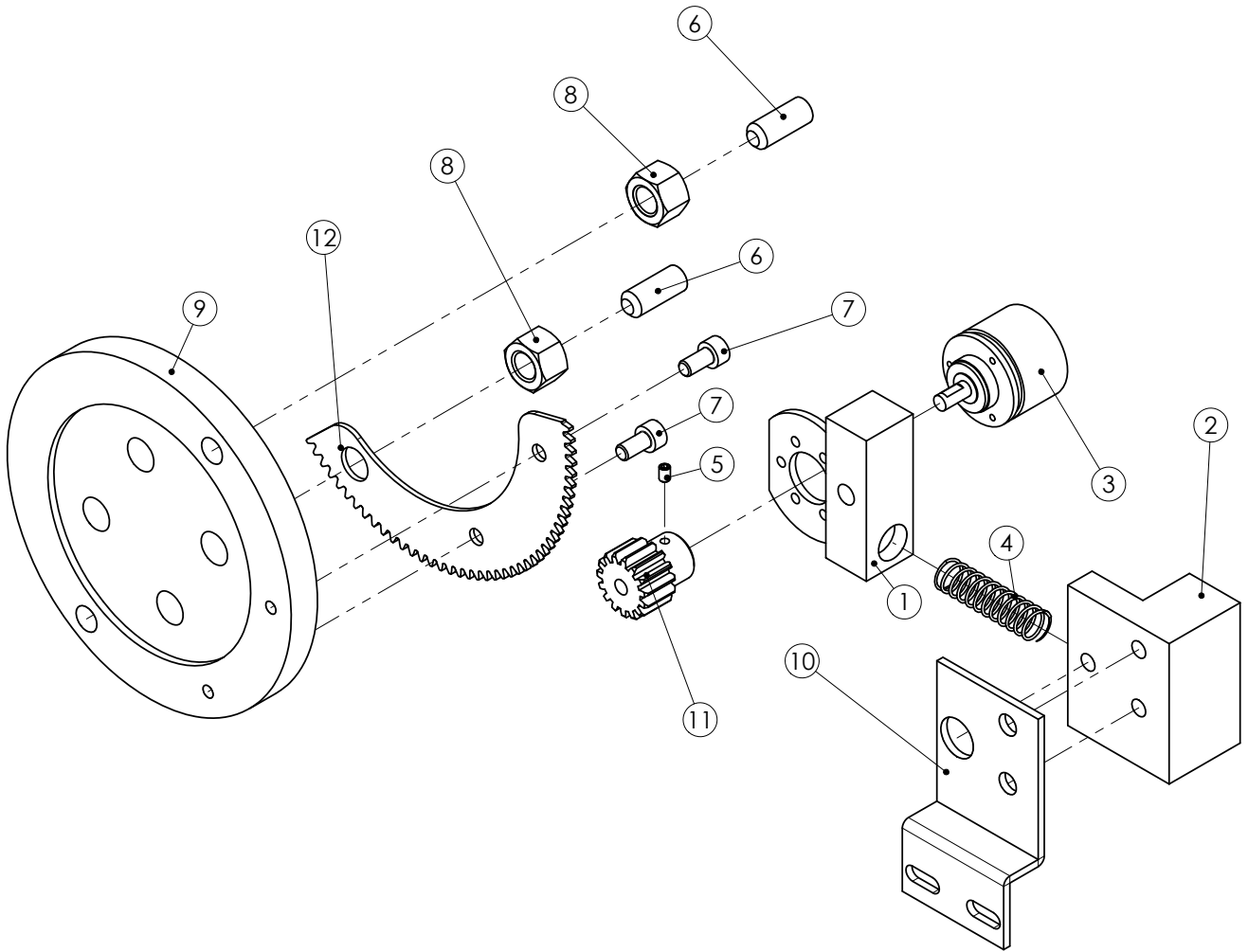



SVC-670DMM / SVC-670DMC / V-2026NC

2015/7/15

VC600D-21000 譯碼器組 ENCODER ASSEMBLY

ITEM	PART NO.	PART NAME	PART NAME IN CHINESE	PART SPEC.	QTY
1	C320G-70536	Encoder fixed seat	譯碼器固定座		1
2	C560L-2103	Encoder movable seat	譯碼器活動座		1
3	EP-90492I	Encoder	譯碼器		1
4	M3L-9-10	Spring	微動彈簧		1
5	PAA-4-6	Set screw	止付螺絲		*
6	PBA-10-25	Hex soc cap screw	內六角螺絲		*
7	PBA-6-12	Hex soc cap screw	內六角螺絲		*
8	POA-12	Nut	螺帽		*
9	SV600D-2107A	Rotating shaft end plate	旋轉軸端板		1
10	VC600D-2101B	Encoder fixed seat	譯碼器固定座		1
11	VC600D-2105	Gear	1.5定寸齒輪		1
12	VC600D-2112	Toothed plate	M1.5齒型板		1

VC600D-37500B 制動器組 BRAKE ASSEMBLY

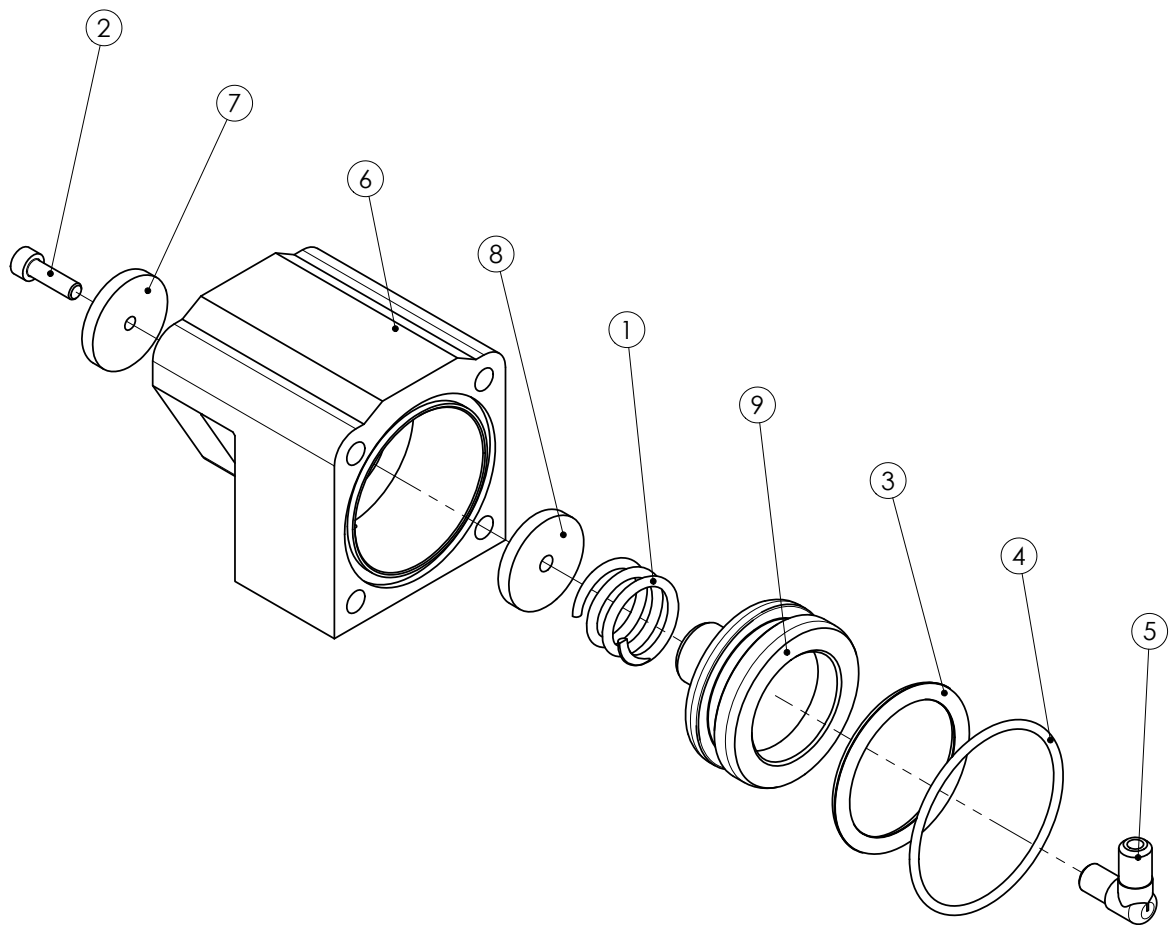



670DMM / SVC-670DMC / V-2026NC

2015/7/15

VC600D-37500B 制動器組 BRAKE ASSEMBLY

ITEM	PART NO.	PART NAME	PART NAME IN CHINESE	PART SPEC.	QTY
1	AHA-0629	buffer spring	緩衝彈簧		1
2	PBA-6-20	Hexagon socket head cap screw	內六角螺絲		*
3	PP-59196	O-ring	O型環		1
4	PP-59570	O-ring	O型環	G-65	1
5	PUI-010-020-04	Connector	直接頭	規格1/8P x 1/4H	1
6	VC600D-3752B	brake supporting seat	制動器支撐座		1
7	VC600D-3753	brake fixed plate	制動固定片		1
8	VC600D-3754	brake movable plate	制動活動片		1
9	VC600D-3755A	brake piston	制動活塞		1

VC600D-39200-張力連桿組
VC670D-33200-張力油壓缸組

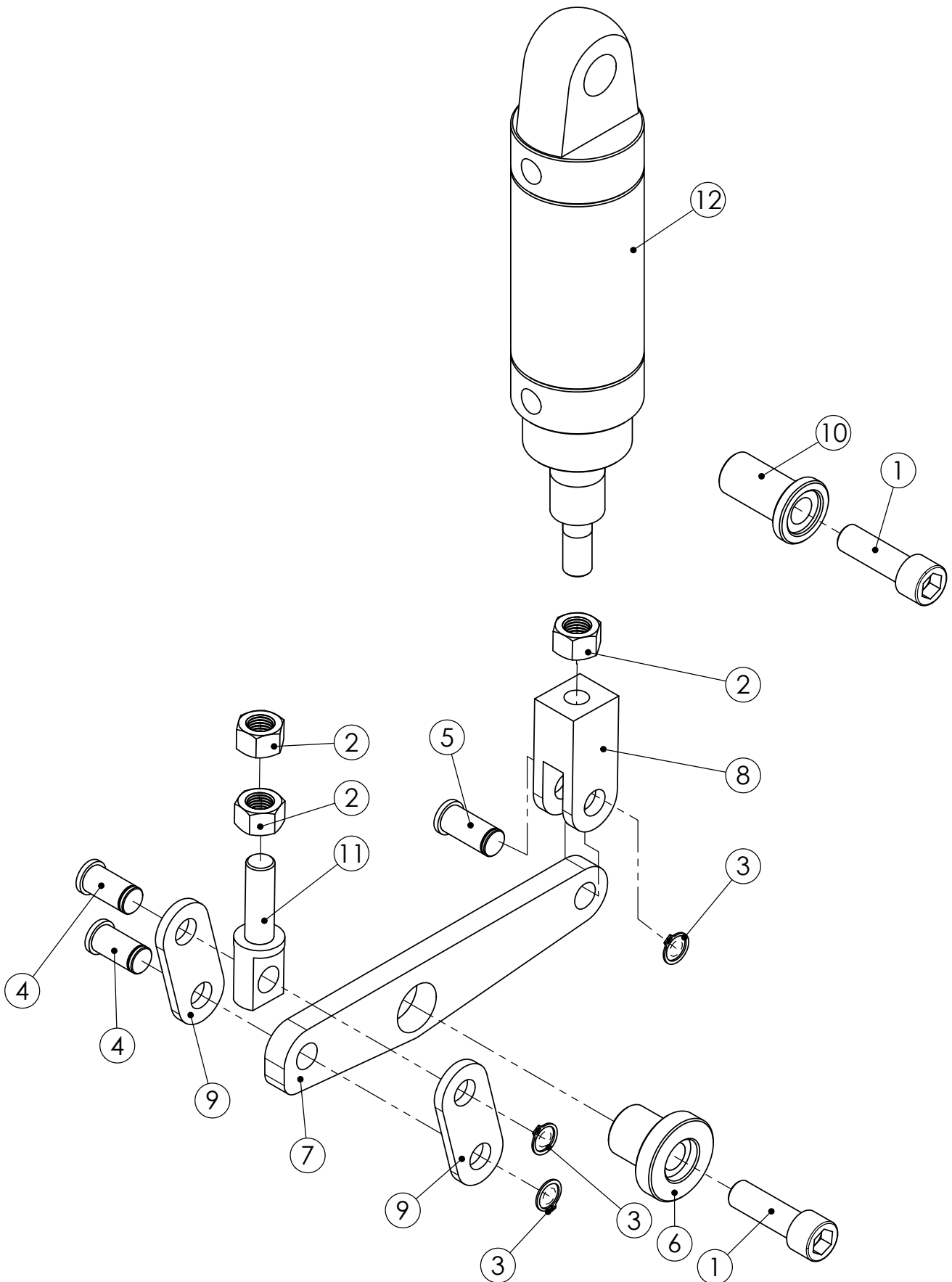



SVC-670DMM / SVC-670DMC / V-2026NC

2015/7/15

VC600D-39200 張力連桿組 TENSIONER SHAFT ASSEMBLY

& VC670D-33200 張力油壓缸組 TENSIONER CYLINDER ASSEMBLY

ITEM	PART NO.	PART NAME	PART NAME IN CHINESE	PART SPEC.	QTY
1	PBA-16-50	Hexagon socket head cap screw	內六角螺絲		*
2	POA-16	nut	螺帽		*
3	PP-52097A	C-ring	C型扣環		3
4	VC600D-3308	tensioner shaft pin 1	張力連桿插銷(一)		2
5	VC600D-3310	tensioner shaft pin 2	張力連桿插銷(二)		1
6	VC600D-3312A	sliding seat shaft press plate	滑座連桿壓板		1
7	VC600D-3316A	tensioner sliding seat shaft	張力滑座連桿		1
8	VC600D-3317A	sliding seat connecting block	滑座連接塊		1
9	VC600D-3318	sliding seat connecting plate	滑座連接板		2
10	VC600D-3322	tension hydraulic cylinder washer	張力油壓缸墊圈		1
11	VC600D-3468	tensioner connecting rod	滑板連接桿		1
12	VC670D-33200	tensioner cylinder assembly	張力油壓缸組		1

VC600D-39500 鋸弓旋轉齒輪組

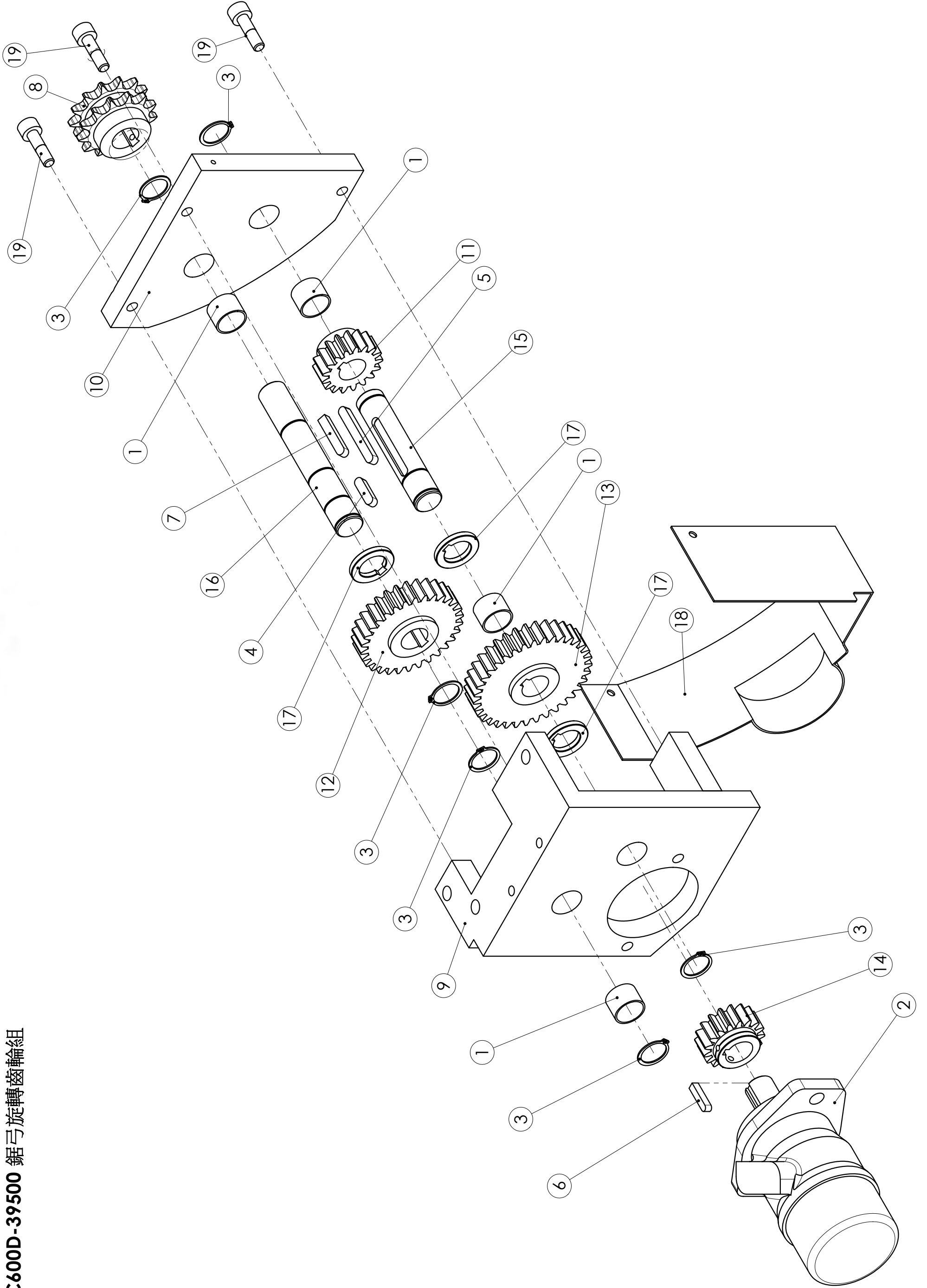



SVC-670DMM / V-2026NC

2015/7/15

VC600D-39500 鋸弓旋轉齒輪組 SAW BOW ROTATING GEAR ASSEMBLY

ITEM	PART NO.	PART NAME	PART NAME IN CHINESE	PART SPEC.	QTY
1	PP-13140	DU bushing	乾式軸承(2520)		4
2	PP-31510	Hydraulic motor	油壓馬達 H-PM125		1
3	PP-52092	C-ring	C型扣環		6
4	PP-91731A	Double head round key	雙圓平行鍵		1
5	PP-91731B	Double head round key	雙圓平行鍵		1
6	PP-91735	Single head round key	單頭平行鍵		1
7	PP-91736	Single head round key	單頭平行鍵		1
8	VC600D-2551A	Chain wheel	鏈輪		1
9	VC600D-3951	Gearbox plate (1)	齒輪箱板(一)		1
10	VC600D-3952	Gearbox plate (2)	齒輪箱板(二)		1
11	VC600D-3956	Gear 1	齒輪(一)		1
12	VC600D-3957	Gear 2	齒輪(二)		1
13	VC600D-3958	Gear 3	齒輪(三)		1
14	VC600D-3959	Gear 4	齒輪(四)		1
15	VC600D-3961	Gear shaft	齒輪軸		1
16	VC600D-3962	Chain wheel shaft	鏈輪軸		1
17	VC600D-3963	Gear shaft washer	齒輪軸墊片		3
18	VC600D-3964	Gearbox cover	齒輪箱護蓋		1



SVC-670DMM / V-2026NC

2015/7/15

VC600D-39500 鋸弓旋轉齒輪組 SAW BOW ROTATING GEAR ASSEMBLY

ITEM	PART NO.	PART NAME	PART NAME IN CHINESE	PART SPEC.	QTY
19	VC600D-3965	Gearbox screw	齒輪箱板銷螺絲		3

VC670D-10000-底座組

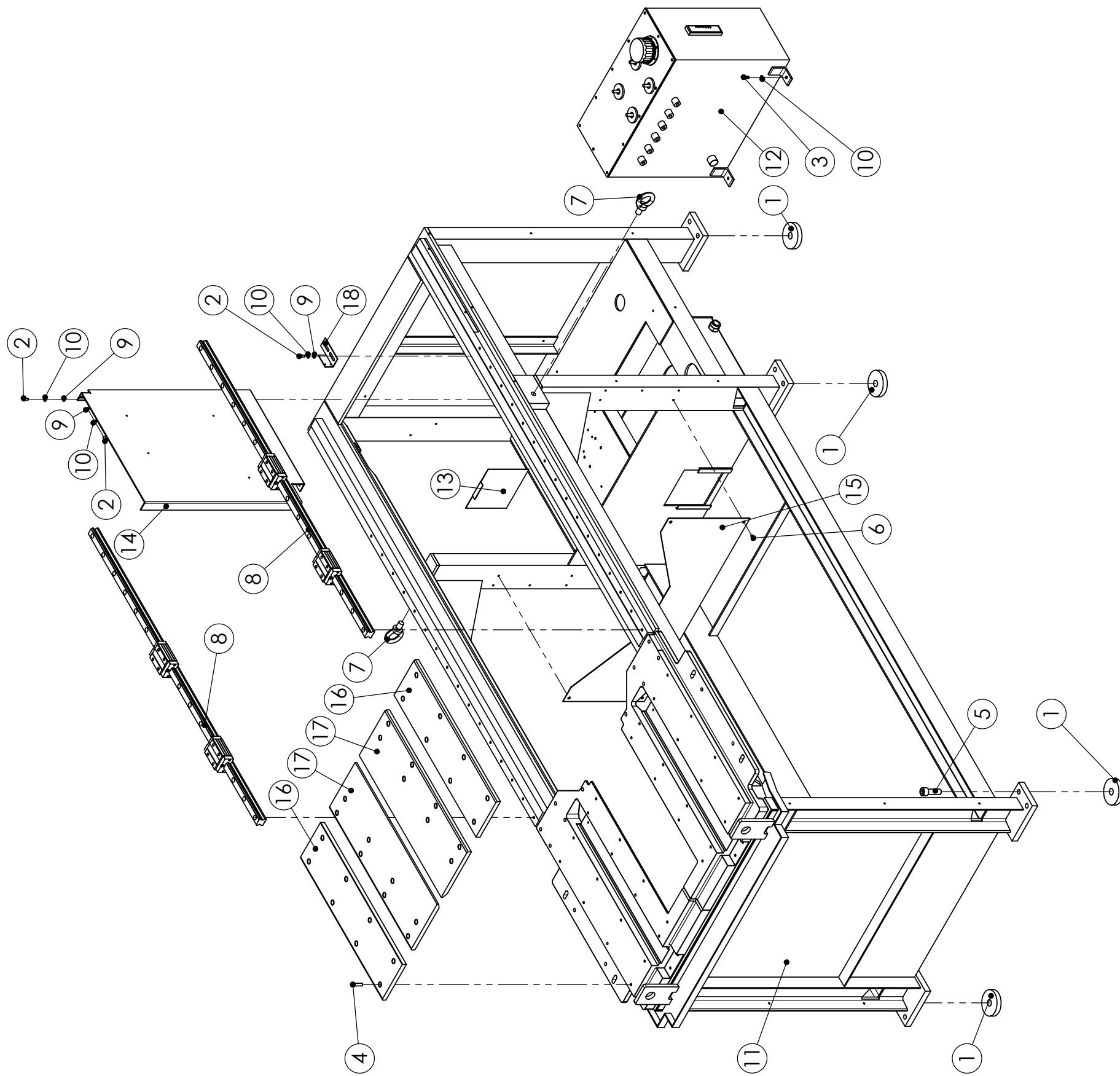



V-2026NC

2015/7/15

VC670D-10000 底座組 BASE ASSEMBLY

ITEM	PART NO.	PART NAME	PART NAME IN CHINESE	PART SPEC.	QTY
1	AHR-1055	table stand pad	底座墊塊		6
2	PBA-6-12	Hexagon socket head cap screw	內六角螺絲		*
3	PBA-6-16	Hexagon socket head cap screw	內六角螺絲		*
4	PBA-8-30	Hexagon socket head cap screw	內六角螺絲		*
5	PBA-16-50	Hexagon socket head cap screw	內六角螺絲		*
6	PHA-6-12	Round head screw	大扁丸頭螺絲		*
7	PP-57905	Eye bolt	環首螺栓		2
8	PP-92007	Linear guide	線性滑軌(含座和塞子)		2
9	PPA-6	flat washer	平面華司		*
10	PQA-6	Spring washer	彈簧華司		*
11	VC670D-1001	base	底座		1
12	VC600D-1002	oil tank assembly	油箱組		1
13	VC600D-1009	tank filter	水箱濾網		1
14	VC670D-1015	manifold plate seat	油路板座		1
15	VC670D-1022	base chip shield	底座擋屑板		1
16	VC670D-2003	bed steel plate 1	床面鋼板(一)		2
17	VC670D-2005	bed steel plate 2	床面鋼板(二)		2
18	VC600D-2887	rear limit fixed plate	後限固定板		1

VC670D-10600-底座護蓋組

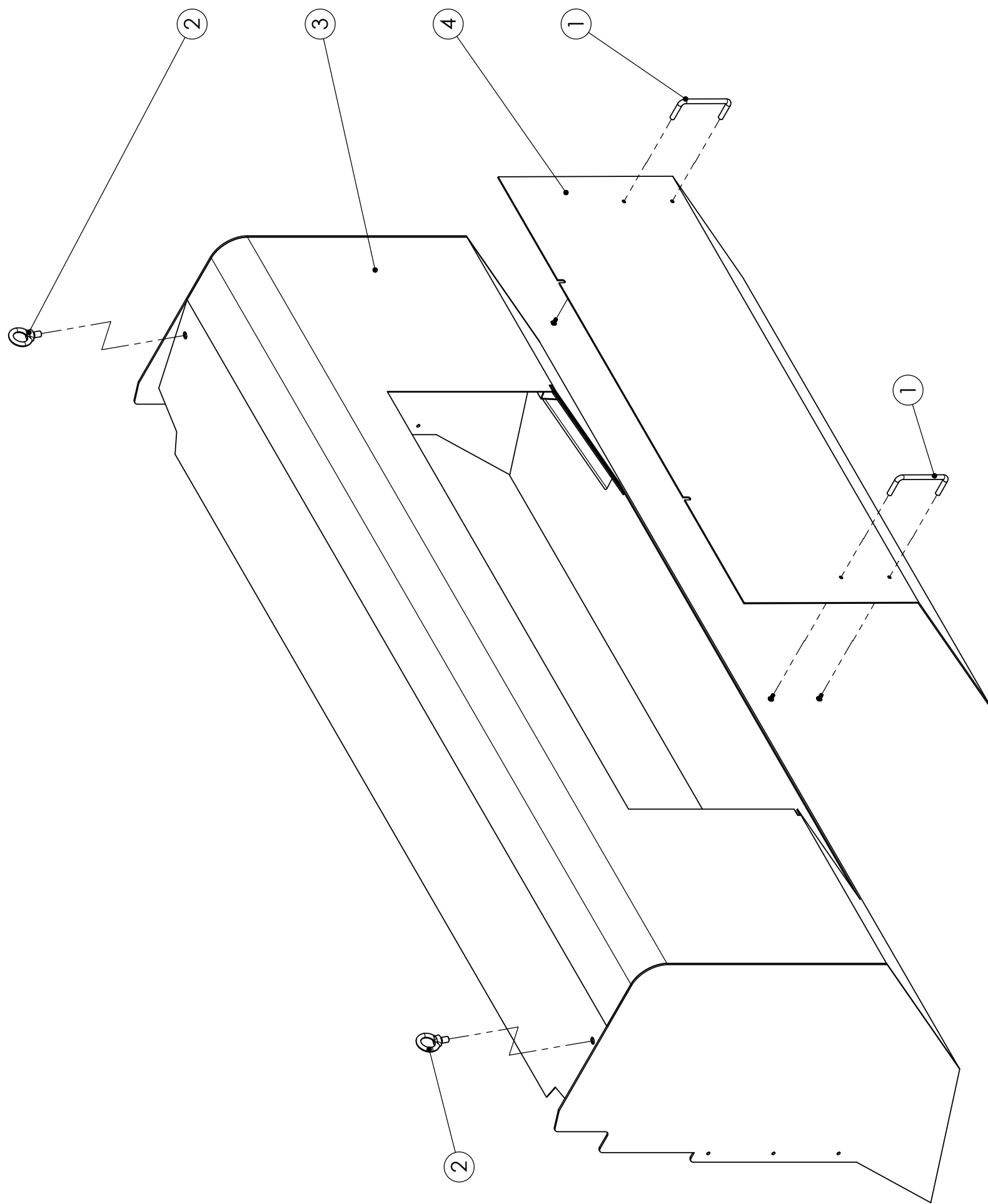



V-2026NC

2015/10/15

VC670D-10600 底座護蓋組 BASE COVER ASSEMBLY

ITEM	PART NO.	PART NAME	PART NAME IN CHINESE	PART SPEC.	QTY
1	PP-52124	Handle	輪箱把手		4
2	PP-57902	Eye bolt	環首螺栓		4
3	VC670D-1043	Base cover	底座護蓋		2
4	VC670D-1044	Base splash shield	底座遮水板		2

VC670D-13000 電控箱組 ELECTRICAL COMPARTMENT ASSEMBLY

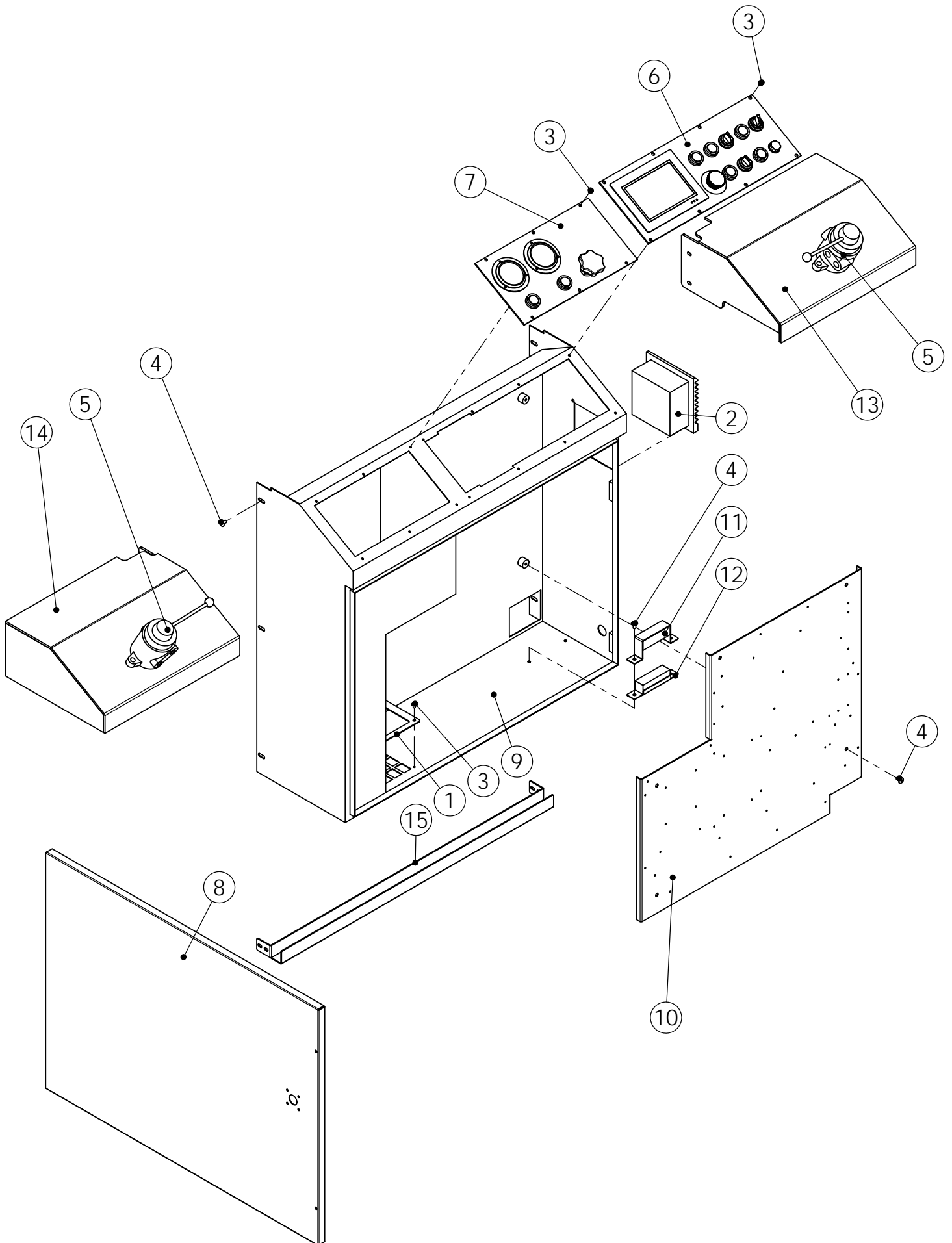



V-2026NC

2015/10/15

VC670D-13000 電控箱組 ELECTRICAL COMPARTMENT ASSEMBLY

ITEM	PART NO.	PART NAME	PART NAME IN CHINESE	PART SPEC.	QTY
1	C250H-1312	Control box gasket	控制箱防塵壓板		1
2	EP-90641-8	fan	風扇		1
3	PBA-5-8	hexagon socket	內六角螺絲		*
4	PHA-6-12	round head screw	大扁丸頭螺絲		*
5	PP-43842	manual direction valve	手動方向閥		2
6	SRF-1213A	pressure control panel assembly	壓力控制面板組		1
7	SV600D-1212D	control panel assembly	控制面板組		1
8	VC600D-1301	control box door cover	控制箱門蓋		1
9	VC600D-1301	control box	控制箱		1
10	VC600D-1302A	circuit board	線路板		1
11	VC600D-1320	Wire fixed Board	電線固定板		1
12	VC600D-1320-1	Foam fixed seat	泡棉固定座		1
13	WVC670D-0001	Manual valve fixed seat - R	手動閥固定座-R		1
14	WVC670D-0002	Manual valve fixed seat - L	手動閥固定座-L		1
15	WVC670D-0003	Wire channel	管線座		1

VC670D-20000-床面組 BED & VISE ASSEMBLY

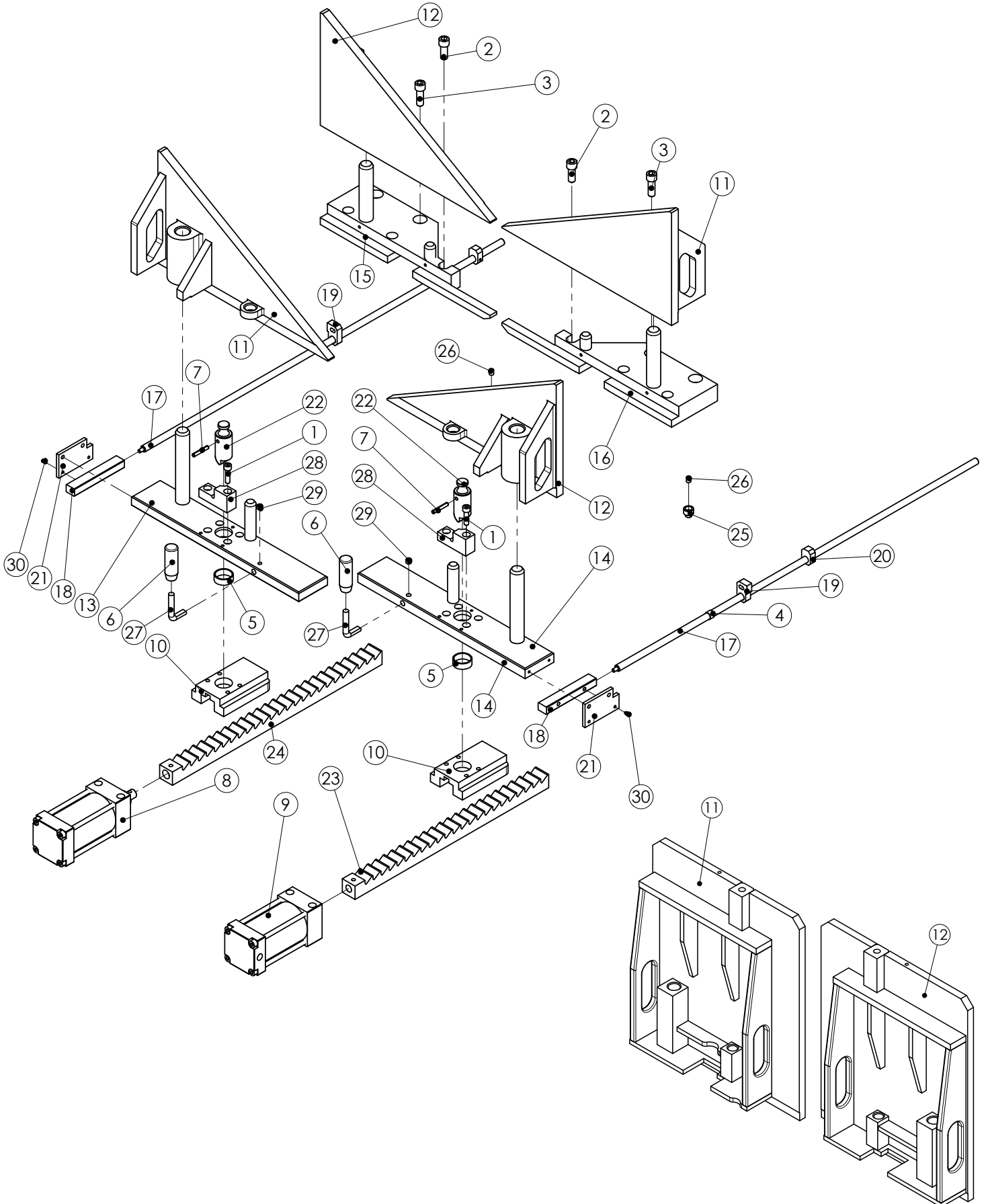



SVC-670DMM / DMC / V-2026NC

2015/10/15

VC670D-20000 床面虎鉗組 BED & VISE ASSEMBLY

ITEM	PART NO.	PART NAME	PART NAME IN CHINESE	PART SPEC.	QTY
1	PBA-8-30	Hexagon socket head cap screw	內六角螺絲		2
2	PBA-12-30	Hexagon socket head cap screw	內六角螺絲		2
3	PBA-12-35	Hexagon socket head cap screw	內六角螺絲		2
4	PP-13021	DU bushing	乾式軸承	MB1210DU	2
5	PP-13190	DU bushing	乾式軸承		2
6	PP-52055	bakelite handle	電木手柄	65mm-M10牙	2
7	PRA-6-36	spring pin	彈簧銷		2
8	SRF-25000A-1	hydraulic cylinder	油壓缸		1
9	SRF-25000B-1	hydraulic cylinder	油壓缸		1
10	VC600D-2225B	vise sliding seat	虎鉗滑座		2
11	VC600D-2241A	vise steel plate (1)	虎鉗鋼板(一)	30°, standard	2
	VC600D-2245A	vise steel plate (3)	虎鉗鋼板(三)	45°, optional	2
	VC600D-2249A	vise steel plate (5)	虎鉗鋼板(五)	90°, optional, Height 229mm	2
	VC600D-2249B	vise steel plate (8)	虎鉗鋼板(八)	90°, optional, Height 500mm	2
12	VC600D-2243A	vise steel plate (2)	虎鉗鋼板(二)	30°, standard	2
	VC600D-2247A	vise steel plate (4)	虎鉗鋼板(四)	45°, optional	2
	VC600D-2251A	vise steel plate (6)	虎鉗鋼板(六)	90°, optional, Height 229mm	2
	VC600D-2251B	vise steel plate (7)	虎鉗鋼板(七)	90°, optional, Height 500mm	2



SVC-670DMM / DMC / V-2026NC

2015/10/15

VC670D-20000 床面虎鉗組 BED & VISE ASSEMBLY

ITEM	PART NO.	PART NAME	PART NAME IN CHINESE	PART SPEC.	QTY
13	VC600D-2252A	left movable vise seat	左活動虎鉗座		1
14	VC600D-2253A	right movable vise seat	右活動虎鉗座		1
15	VC600D-2254A	left fixed vise seat	左固定虎鉗座		1
16	VC600D-2255A	right fixed vise seat	右固定虎鉗座		1
17	VC600D-2281	Sensing rod	感應器滑桿		2
18	VC600D-2282	Sliding bar fixed seat	滑桿固定座		2
19	VC600D-2284A	Sliding bar bracket	滑桿支架		2
20	VC600D-2285	Sliding bar sensing block	滑桿感應塊		2
21	VC600D-2286A	rod connecting plate	滑桿連接板		2
22	VC600D-2701A	pawl	施力板		2
23	VC670D-2703	rack gear	浪形板		1
24	VC670D-2703	rack gear	浪形板		1
25	VC600D-2704	rack gear sliding block	浪形板滑塊		2
26	VC600D-2705	rack gear position ring	浪形板定位環		2
27	VC600D-2713	handle shaft	把手軸心		2
28	VC600D-2714	pawl holder	施力板支座		2
29	PAA-10-8	Set screw	止附螺絲		2
30	PAA-5-10	Set screw	平頭止付	M5x10	2

VC670D-30000-鋸弓組

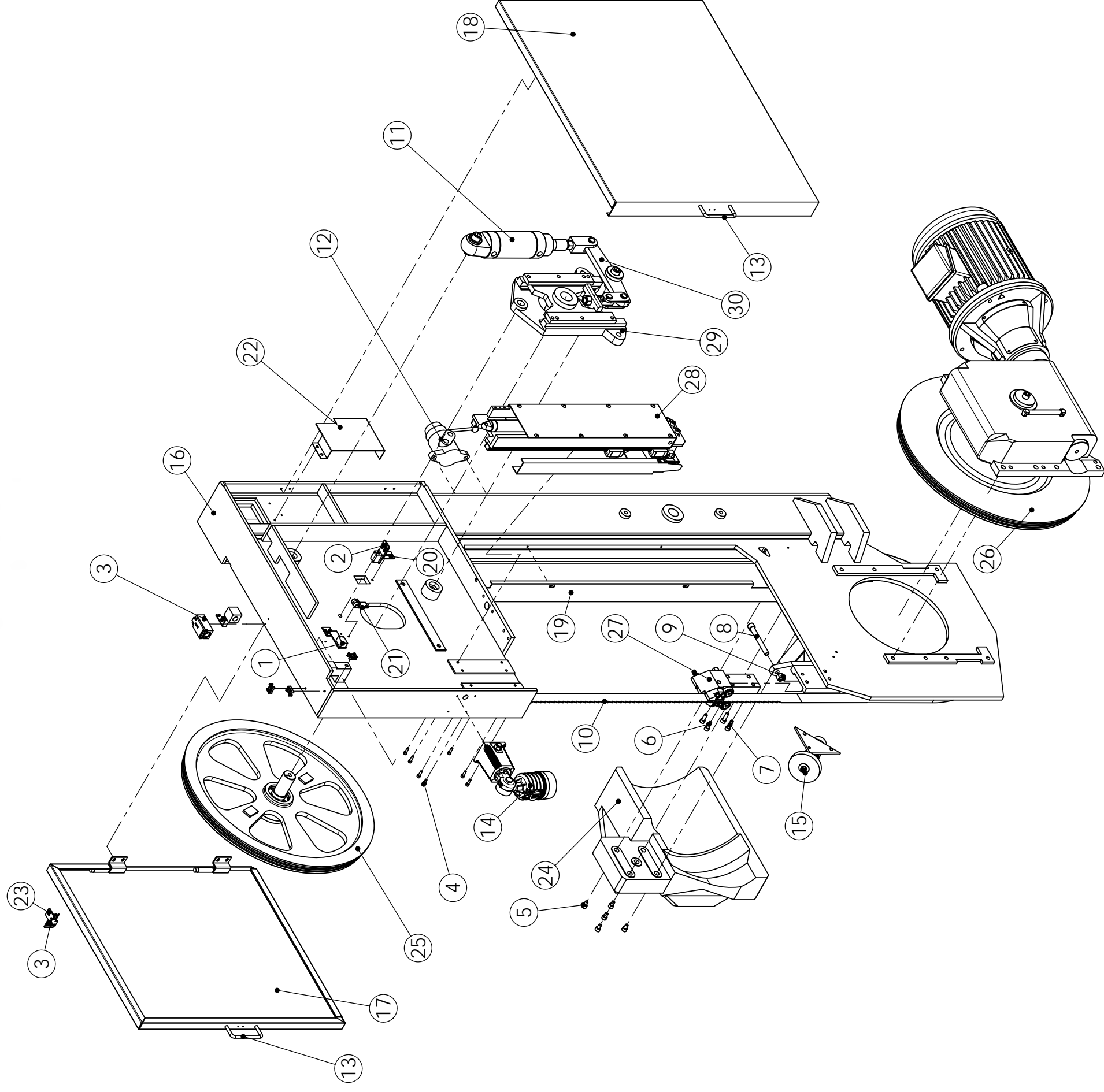



V-2026NC

2015/7/15

VC670D-30000 鋸弓組 SAW BOW ASSEMBLY

ITEM	PART NO.	PART NAME	PART NAME IN CHINESE	PART SPEC.	數量
1		sensor assembly	感應器組		1
2	AHA-0672A	Sensor base plate	感應器底板		1
3	AZD-S11	safety switch assembly	安全開關組		1
4	PBA-5-16	Hexagon socket head cap screw	內六角螺絲		*
5	PBA-8-12	Hexagon socket head cap screw	內六角螺絲		*
6	PBA-8-20	Hexagon socket head cap screw	內六角螺絲		*
7	PBA-8-25	Hexagon socket head cap screw	內六角螺絲		*
8	PBA-12-100	Hexagon socket head cap screw	內六角螺絲		*
9	POA-12	Nut	螺帽		*
10	PP-18252	saw blade	鋸帶		1
11	PP-43436B	hydraulic cylinder	油壓缸		1
12	PP-43842	manual direction valve	手動方向閥		1
13	PP-52124	Handle	輪箱把手		2
14	PP-91804E	work lamp	工作燈		1
15	S500M-32200	wire brush assembly	鋼刷組		1
16	VC670D-3001	saw bow	鋸弓		1
17	VC670D-3003	Tension wheel cover	張力輪箱蓋		1

VC670D-30000 鋸弓組 SAW BOW ASSEMBLY

ITEM	PART NO.	PART NAME	PART NAME IN CHINESE	PART SPEC.	數量
18	VC670D-3004	Tension cover	張力護蓋		1
19	VC670D-3007	saw blade cover	鋸帶護蓋		1
20	VC600D-3053	sensor seat	感應器底板座		1
21	VC600D-3467	coolant fitting	切削水接頭		1
22	VC600D-3469	terminal cover	鋸弓線路端子護蓋		1
23	VC600D-3470	idle wheel cover switch seat	上輪箱插銷座		1
24	VC600D-3494	balance weight 3	配重塊(三)		1
25	VC670D-30300	idle wheel assembly	上輪組		1
26	VC670D-30400	Drive wheel assembly	主動輪組		1
27	VC670D-31000	fixed saw arm assembly	鋸臂組		1
28	VC670D-31000A	Movable saw arm assembly	活動鋸臂組		1
29	VC670D-33000	tensioner sliding seat assembly	張力滑座滑板組		1
30	VC600D-39200	tensioner shaft assembly	張力連桿組		1

VC670D-30300 張力輪組

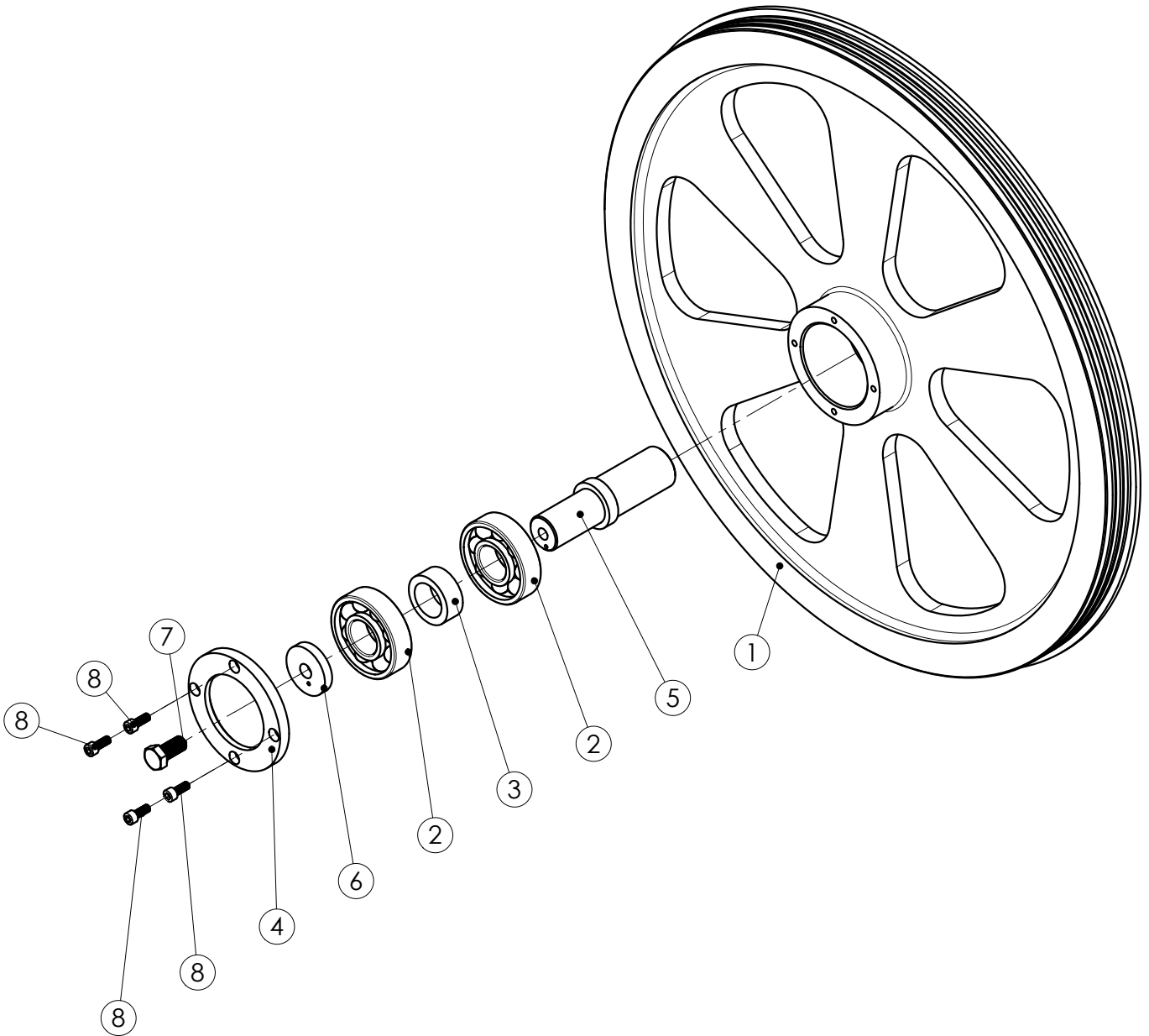



V-2026NC

2015/7/15

VC670D-30300 張力輪組 IDLE WHEEL ASSEMBLY

ITEM	PART NO.	PART NAME	PART NAME IN CHINESE	PART SPEC.	QTY
1	VC670D-3031	idle wheel	張力輪		1
2	PP-14294	bearing	軸承		2
3	SRF-2905	distance ring	間隔環		1
4	SRF-2906	fixed ring (idle wheel)	固定環(上輪)		1
5	VC600D-3033	idle wheel shaft	上輪軸		1
6	SRF-2913	idle wheel washer	上輪墊片		1
7	PLA-12-25A	Hexagon head cap screw	外六角螺絲		1
8	PBA-6-16	Hexagon socket head cap screw	內六角螺絲		4

VC670D-31000A - 活動鋸臂組

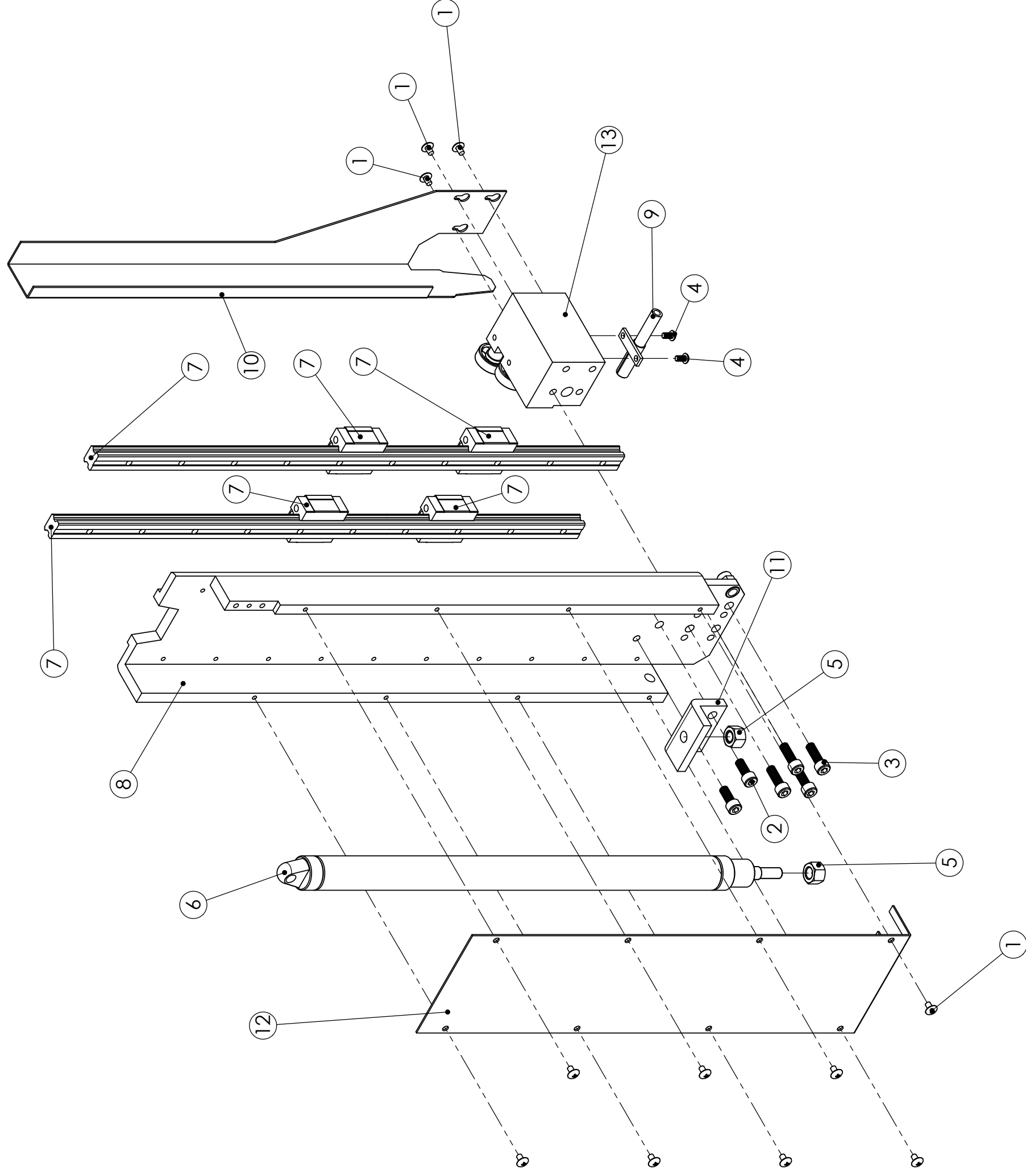



V-2026NC

2015/7/15

VC670D-31000A 活動鋸臂組 MOVABLE SAW ARM ASSEMBLY

ITEM	PART NO.	PART NAME	PART NAME IN CHINESE	PART SPEC.	QTY
1	PBA-5-8	hexagon socket	內六角螺絲		*
2	PBA-8-20	Hexagon socket head cap screw	內六角螺絲		*
3	PBA-8-25	Hexagon socket head cap screw	內六角螺絲		*
4	PGC-5-10	Cup head screw	半圓頭螺絲		*
5	POA-12	Nut	螺帽		*
6	PP-43380B	Hydraulic cylinder	油壓缸		1
7	PP-92008	linear guide+sliding block	滑軌+滑塊		1
8	VC600D-3103	movable guide arm	活動鋸臂		1
9	VC600D-3183	spray nozzle	冷卻水噴嘴		1
10	VC670D-3483	Saw arm splash shield	鋸臂擋水板		1
11	VC600D-3486	adaptor plate	鋸臂油缸轉接板		1
12	VC600D-3496	guide arm shield	鋸臂遮板		1
13	VC670D-31300	Upper guide roller assembly	上導輪座組		1

VC670D-31000-鋸臂組

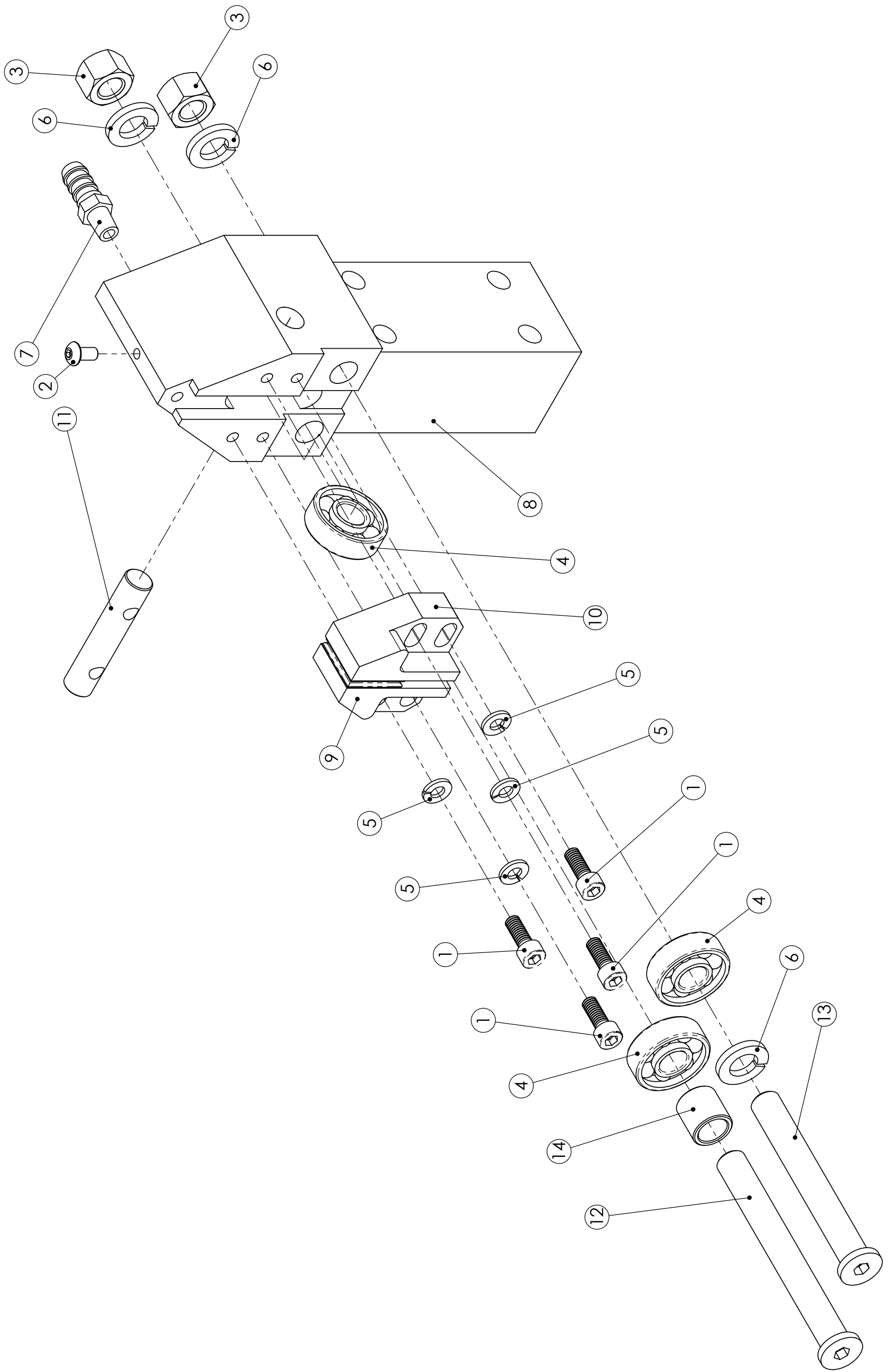



V-2026NC

2015/7/15

VC670D-31000 固定鋸臂組 FIXED SAW ARM ASSEMBLY

ITEM	PART NO.	PART NAME	PART NAME IN CHINESE	PART SPEC.	QTY
1	PBA-6-16	Hexagon socket head cap	內六角螺絲		*
2	PGC-5-10	Round head screw	半圓頭螺絲		*
3	POA-12	Nut	螺帽		*
4	PP-14271A	bearing	軸承		3
5	PQA-6	Spring washer	彈簧華司		*
6	PQA-12	Spring washer	彈簧華司		*
7	PUI-010-030-01	coolant fitting	水管接頭		1
8	VC670D-3105	fixed saw arm	固定鋸臂		1
9	VC600D-3133A	carbide insert	固定鎢鋼片(一)		1
10	VC600D-3133B	carbide insert-R	固定鎢鋼片(二)		1
11	VC600D-3139A	bearing pin	軸承銷		1
12	VC600D-3141	guide roller shaft 1	導輪軸(一)		1
13	VC600D-3143	guide roller shaft 2	導輪軸(二)		1
14	VC600D-3145	washer	墊圈		1

VC670D-31300-上導輪座組

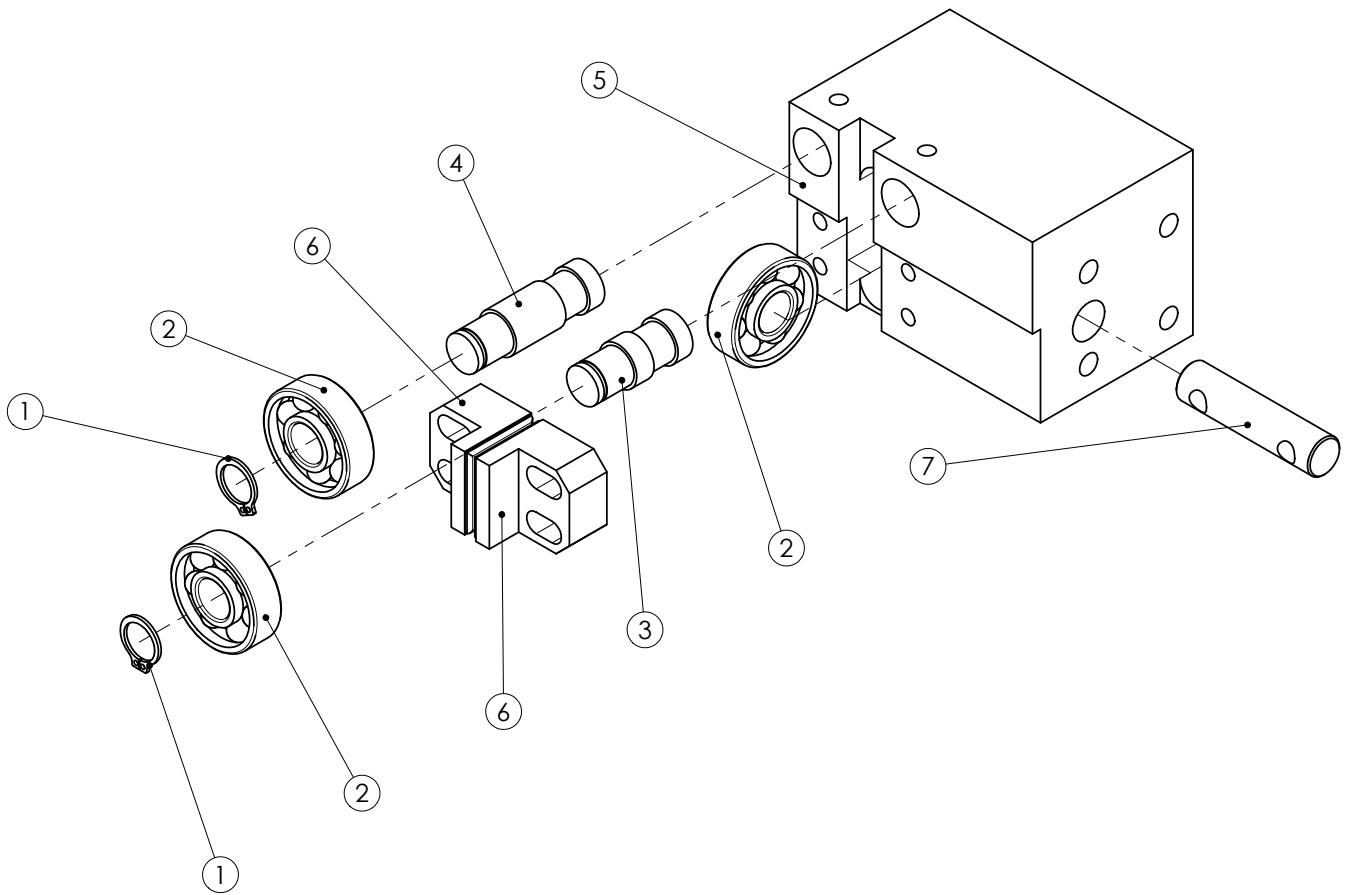



SVC-670DMM / SVC-670DMC / MVC-670DM / V-2026NC

2015/7/15

VC670D-31300 上導輪座組 UPPER GUIDE ROLLER ASSEMBLY

ITEM	PART NO.	PART NAME	PART NAME IN CHINESE	PART SPEC.	QTY
1	PP-52085	C-ring	C型扣環		2
2	PP-14271A	bearing	軸承		3
3	SRF-3202A	guide roller shaft 2	導輪軸(2)		1
4	SRF-3202	guide roller shaft 1	導輪軸(1)		1
5	VC670D-3131	guide roller seat	導輪座		1
6	VC600D-3133	fixed carbide insert	固定鎢鋼片		2
7	VC600D-3139	bearing pin	軸承銷		1

VC670D-33000 張力滑座組 TENSIONER SLIDING SEAT ASSEMBLY

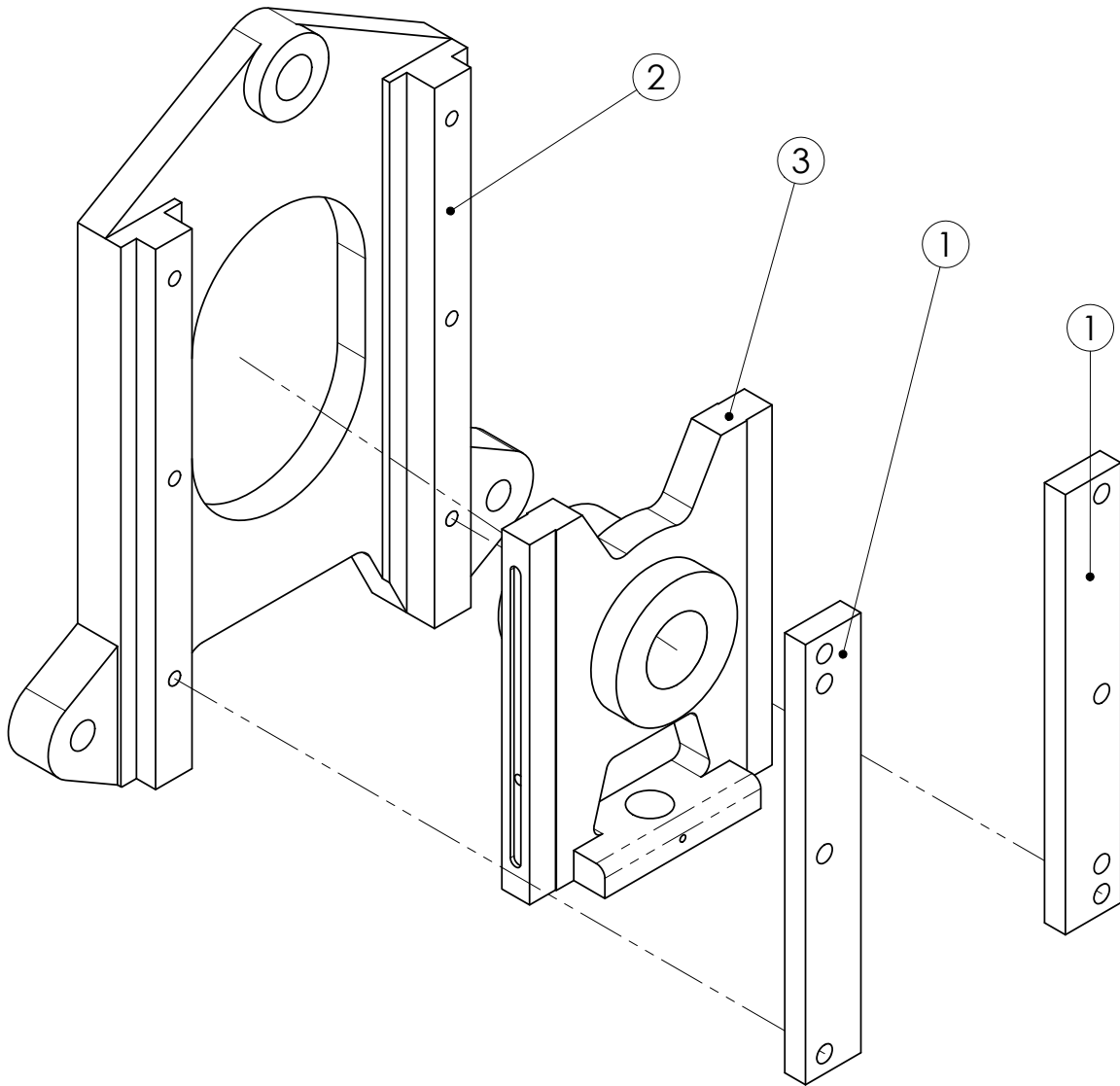



SVC-670DMM / SVC-670DMC / V-2026NC

2015/7/15

VC670D-33000 張力滑座滑板組 TENSIONER SLIDING SEAT ASSEMBLY

ITEM	PART NO.	PART NAME	PART NAME IN CHINESE	PART SPEC.	QTY
1	SV600D-2905	tensioner press plate 1	張力壓板(一)		2
2	VC600D-3301	tensioner sliding seat	張力滑座		1
3	VC600D-3303	tensioner sliding plate	張力滑板		1

S500M-32200 鋼刷組

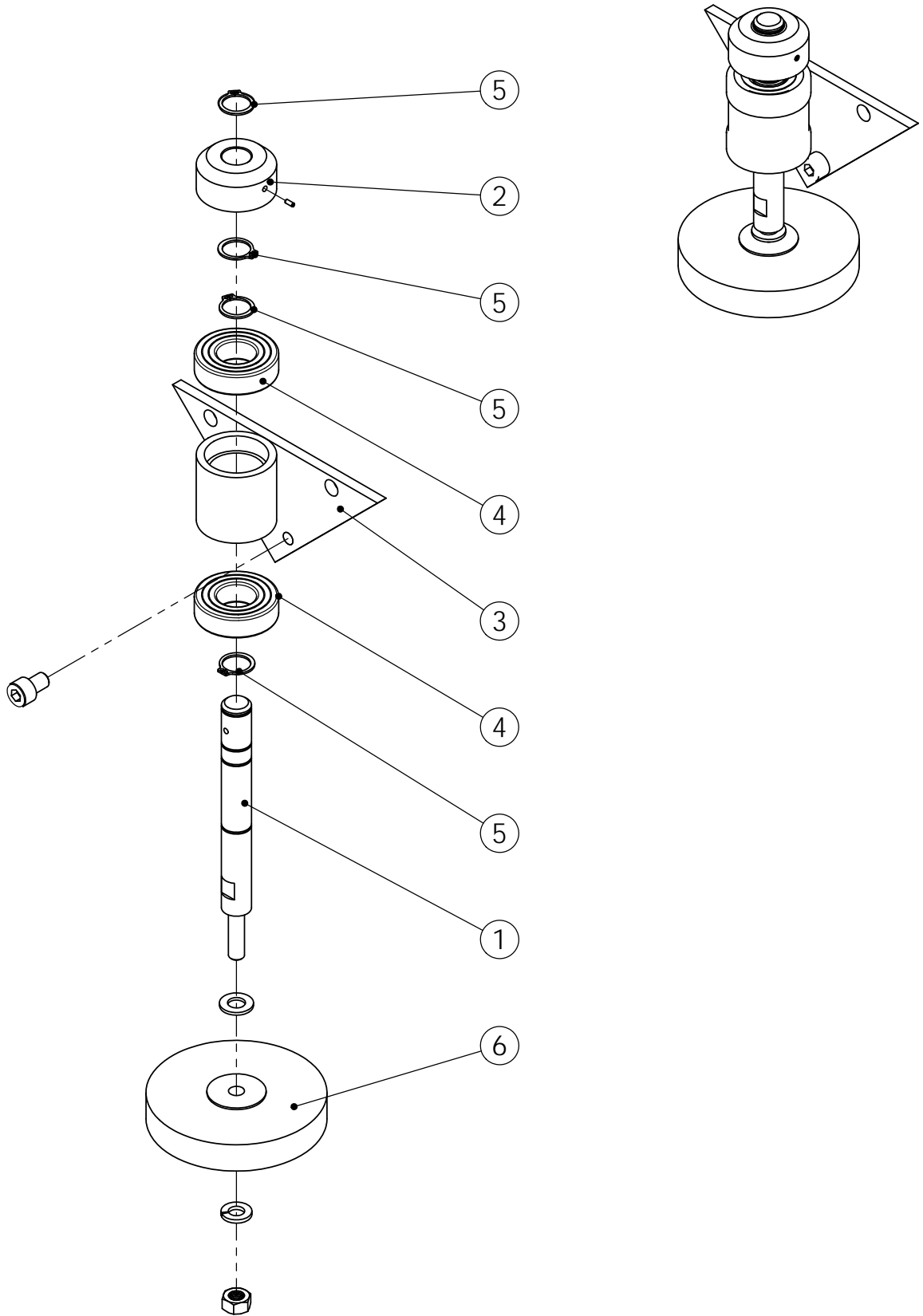



V-2026NC

2015/7/15

S500M-32200 鋼刷組 WIRE BRUSH ASSEMBLY

ITEM	PART NO.	PART NAME	PART NAME IN CHINESE	PART SPEC.	QTY
1	MBR-9129	Wire brush shaft	鋼刷軸		1
2	MBR-9131	Brush drive wheel	鋼刷傳動輪		1
3	MBR-9132-B	Wire brush bearing seat	鋼刷軸承座		1
4	PP-14250	Bearing	軸承	6002ZZ	2
5	PP-52097	C-ring	C型扣環		4
6	PP-58002	Wire brush	鋼刷		1

VC670D-34500-鋸弓滑軌組 SAW BOW ROTATING ASSEMBLY

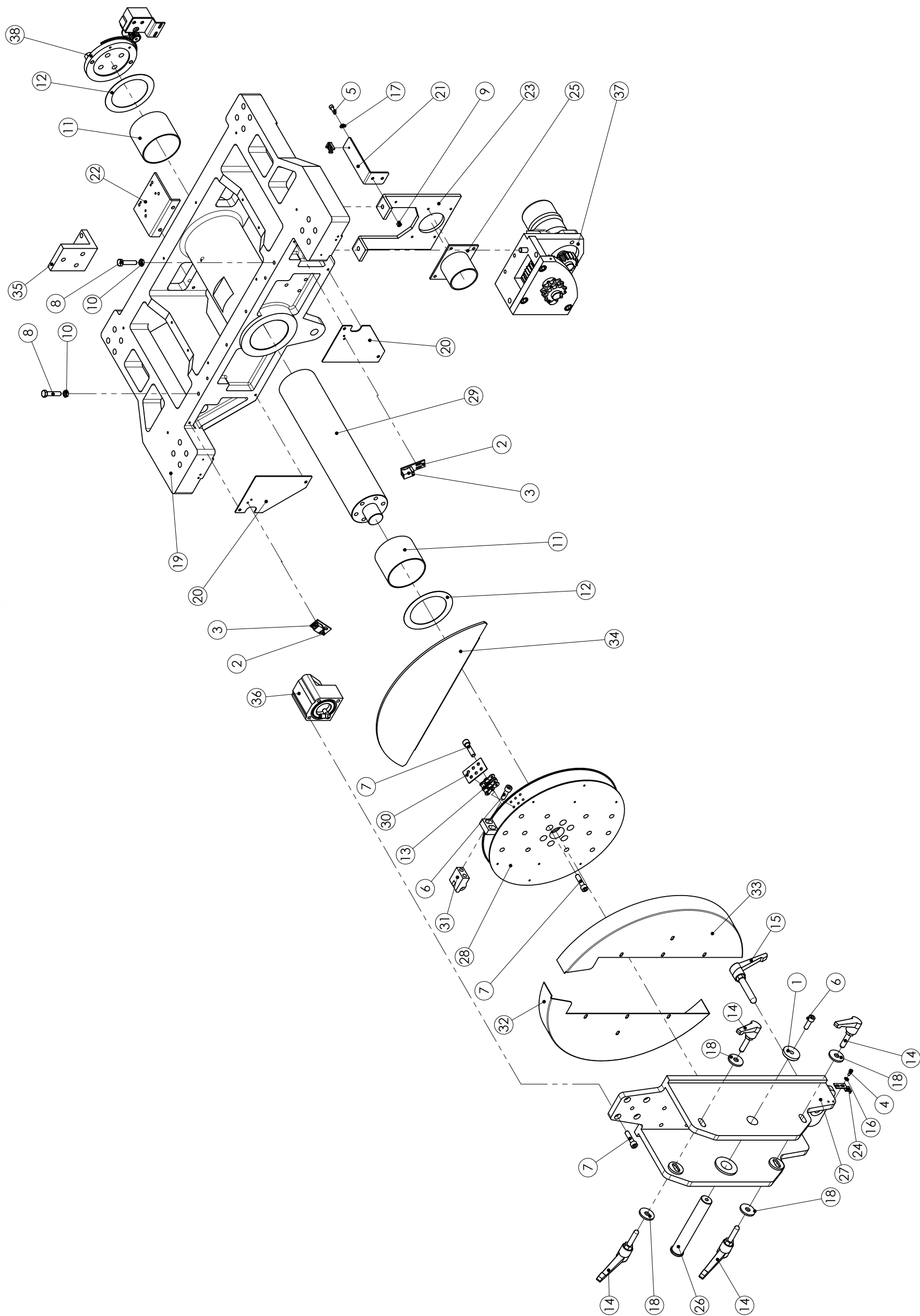



V-2026NC

2015/7/15

VC670D-34500 鋸弓滑軌組 SAW BOW ROTATING ASSEMBLY

ITEM	PART NO.	PART NAME	PART NAME IN CHINESE	PART SPEC.	QTY
1	AHA-0525	washer	墊圈		1
2	AHA-0672A	Sensor base plate	感應器底板		2
3	EP-90432-1	Proximity switch	近接開關		2
4	PBA-5-12	Hexagon socket head cap screw	內六角螺絲		*
5	PBA-6-20	Hexagon socket head cap screw	內六角螺絲		*
6	PBA-10-30	Hexagon socket head cap screw	內六角螺絲		*
7	PBA-10-40	Hexagon socket head cap screw	內六角螺絲		*
8	PLA-10-40	hexagon bolt	外六角螺絲		*
9	POA-6	Nut	螺帽		*
10	POA-10	Nut	螺帽-薄型		*
11	PP-13295D	DU bushing	乾式軸承		2
12	PP-14444	thrust collar	推力圈AS100		2
13	PP-19004	chain	鍊條		1
14	PP-52054	adjusting handle	調整式手輪		4
15	PP-52111I	saw arm handle	鋸臂手把		1
16	PPA-5	flat washer	平面華司		*
17	PPA-6	flat washer	平面華司		*

VC670D-34500 鋸弓滑軌組 SAW BOW ROTATING ASSEMBLY

ITEM	PART NO.	PART NAME	PART NAME IN CHINESE	PART SPEC.	QTY
18	PPA-12D	flat washer	平面華司	13X40X4T	*
19	VC600D-2001	bed slide	床面滑台		1
20	VC600D-2036	bed cover	床面遮板		2
21	VC600D-2394	utility lines fixed seat A	管線固定座A		1
22	VC600D-2553	continuous track fixed plate	履帶固定板		1
23	VC600D-3476	utility lines fixed seat	管線固定座		1
24	VC600D-3480	angle pointer	角度指針		1
25	VC600D-3481	protection sleeve seat	油電護管座		1
26	VC600D-3485	shaft	前傾軸心		1
27	VC600D-3487A	saw bow rotating seat	鋸弓旋轉座		1
28	VC600D-3488	saw bow rotating plate	鋸弓旋轉盤		1
29	VC600D-3489	saw bow rotating shaft	鋸弓旋轉軸		1
30	VC600D-3495	chain press plate	鏈條壓板		1
31	VC600D-3497	chain fixed block	鏈條固定塊		1
32	VC600D-3498	chain cover 1	鏈條護蓋(一)		1
33	VC600D-3499	chain cover 2	鏈條護蓋(二)		1
34	VC600D-3751A	brake plate	制動盤		1



V-2026NC

2015/7/15

VC670D-34500 鋸弓滑軌組 SAW BOW ROTATING ASSEMBLY

ITEM	PART NO.	PART NAME	PART NAME IN CHINESE	PART SPEC.	QTY
35	VC600D-3954	reinforced plate	齒輪箱固定座加強板		1
36	VC600D-37500B	saw bow rotating brake assembly	制動器組		1
37	VC600D-39500	rotating gear assembly	鋸弓旋轉齒輪組		1
38	VC600D-21000	encoder assembly	譯碼器組		1



05SVC-670DMM-03

05V-2026NC/05V-2230NC/05V-1822NC

V600D-33500A 減速機組

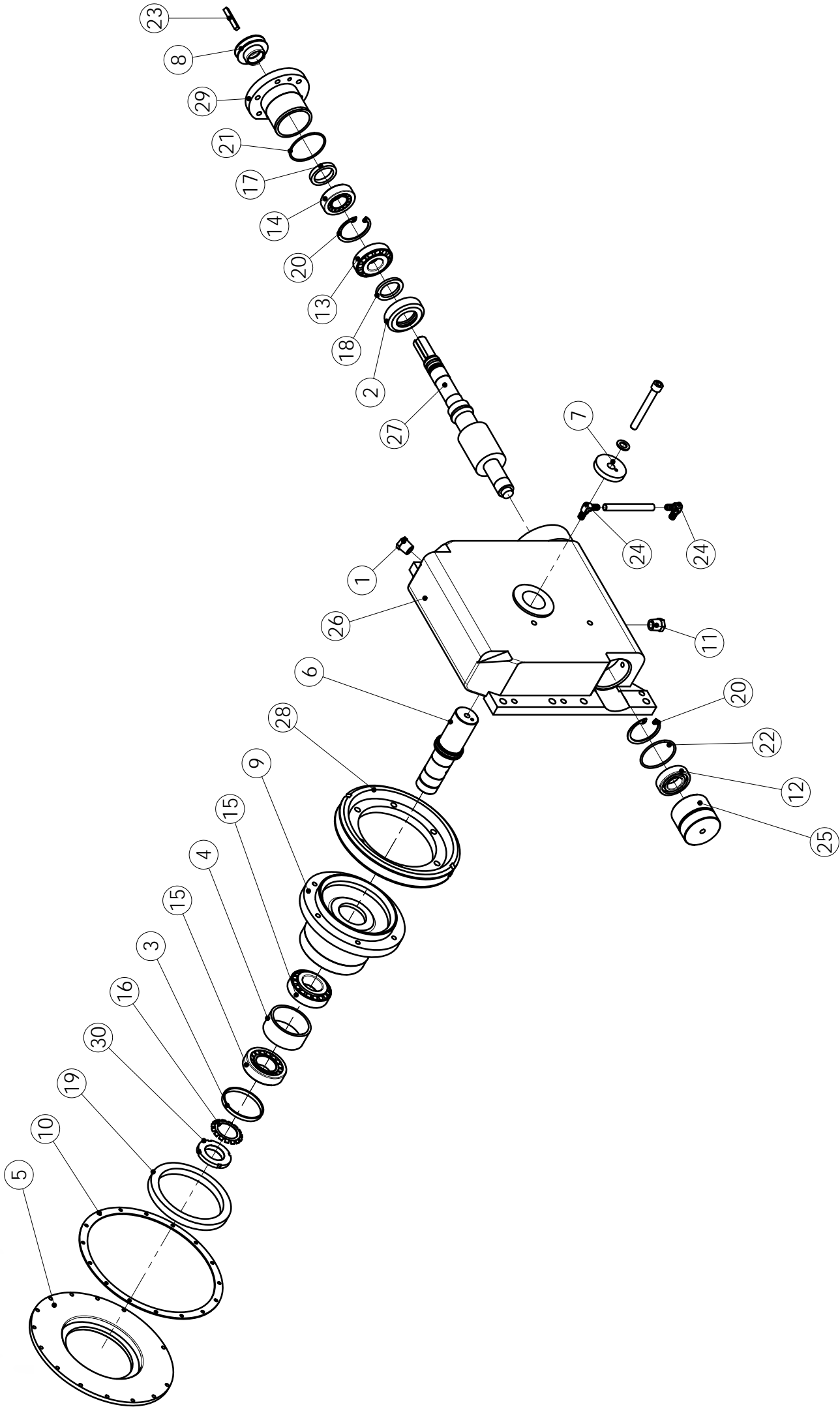



V-2026NC/V-2230NC/V-1822NC/SVC-670DMM-03

2015/11/13

V600D-33500A 減速機組

ITEM	PART NO.	PART NAME	PART NAME IN CHINESE	PART SPEC.	QTY
1	AHA-0307	Plug	透氣塞頭		1
2	AHA-0314	Fixed seat cover	固定座蓋		1
3	AHA-0429	Adjusting ring	調整環		1
4	AHA-0431B	Bearing washer	軸承墊圈		1
5	AHA-0433A	Oil fixed plate	油封固定盤		1
6	C250H-3043	Drive wheel shaft	下輪軸		1
7	C250H-3046	Drive wheel shaft fixed washer	下輪軸固定華司		1
8	C250H-3061	Wire brush pulley	鋼刷普利		1
9	C250H-3365	Housing	蝸輪固定座		1
10	C250H-3369	Gear reducer rubber washer	減速機橡膠墊片		1
11	PED-025	Hexagon plug	外六角塞頭(英)	1/2PT	1
12	PP-14131	Bearing	軸承	6206Z SKF	1
13	PP-14652A	Ball bearing	滾錐軸承	30306D	1
14	PP-14691	Ball bearing	滾錐軸承	32206	1
15	PP-14693B	Ball bearing	滾錐軸承	32208	2
16	PP-14958	Stop ring	止動環	AW08	1
17	PP-51070	Oil Seal	油封	38.50.8	1



V-2026NC/V-2230NC/V-1822NC/SVC-670DMM-03

2015/11/13

V600D-33500A 減速機組

ITEM	PART NO.	PART NAME	PART NAME IN CHINESE	PART SPEC.	QTY
18	PP-51080	Oil Seal	油封	38*52*5	1
19	PP-51090B	Oil Seal	油封	130x160x14T	1
20	PP-58103	Interlock	內鎖	R62	2
21	PP-59015	O-ring	O型環	AS-568 147	1
22	PP-59570	O-ring	O型環	G65	1
23	PP-91708B	Key	方鍵	7x7x50	1
24	PUJ-010-025-01	Elbow joint	彎接頭	1/8P x5/16E	2
25	SV600D-3024	Bearing seat (2)	軸承座(二)		1
26	VC600D-3351	Gear reducer body	減速機本體		1
27	VC600D-3353A	Worm shaft	蝸桿 1/45		1
28	VC600D-3355A	Worm gear	蝸輪 1/45		1
29	VC670D-3361	Bearing seat	軸承座		1
30	PP-14908	Fixed nut	固定螺母	AN08	1

VC600D-41000 下壓組

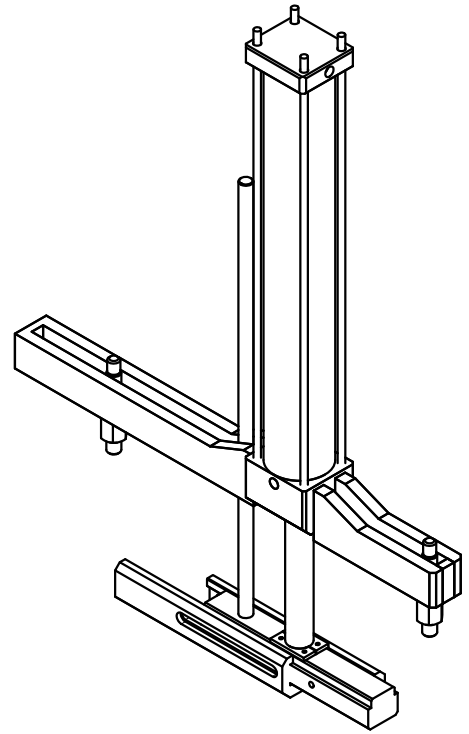
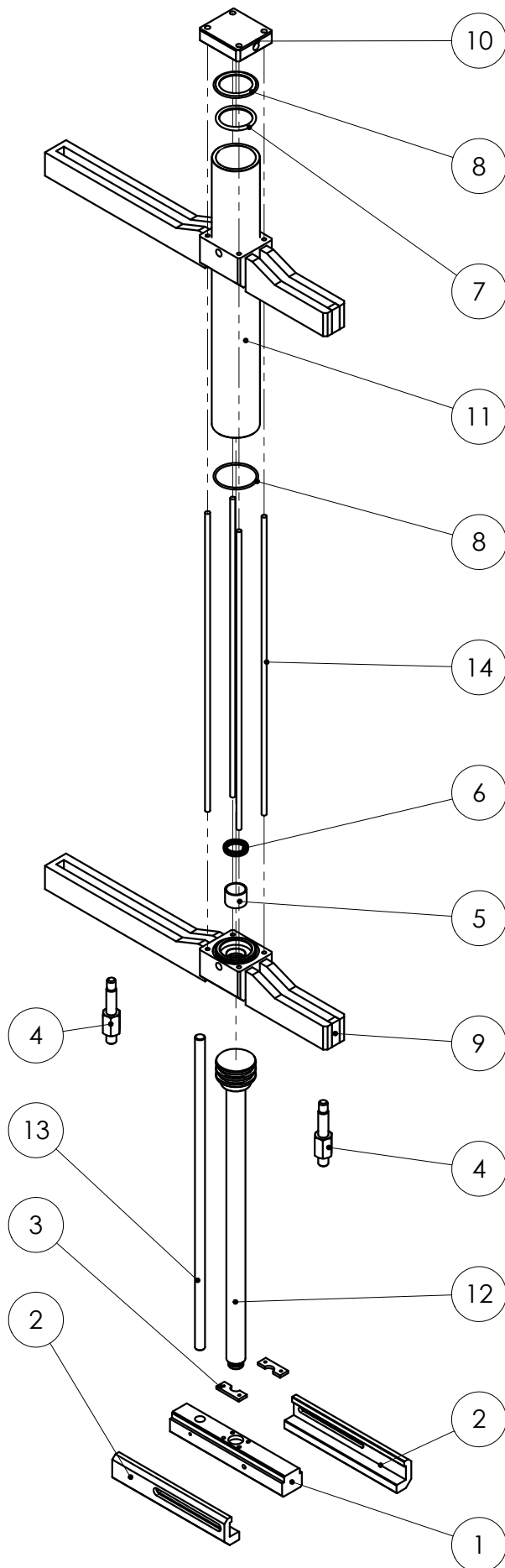



V-2026NC

2015/10/15

VC600D-41000 下壓組 TOP CLAMP ASSEMBLY

ITEM	PART NO.	PART NAME	PART NAME IN CHINESE	PART SPEC.	QTY
1	AGB-70908	Press down plate	壓板(下壓)		1
2	AGB-70909A	Press down plate	下壓板		2
3	AHB-1921	Position plate for bolt	螺桿定位板(下壓)		2
4	C460H-2431	Top clamp fixed bolt	下壓固定螺栓		2
5	PP-13200	DU bushing	乾式軸承	3025	1
6	PP-51041	U type oil seal	U型油封	USH-30	1
7	PP-59150	O-ring	O型環	P-53	2
8	PP-59570	O-ring	O型環	G65	2
9	VC600D-4101	Clamping seat	下壓座		2
10	VC600D-4102	Top clamp cylinder rear cover	下壓油缸後蓋		1
11	VC600D-4103	Tube	缸筒(下壓)		1
12	VC600D-4104	Piston and shaft	活塞及桿		1
13	VC600D-4105	Top clamp position rod	下壓定位桿		1
14	VC600D-4106	Top clamp cylinder rod	下壓連桿		4



Vertical Plate Saws
Horizontal Billet Saws
NC/CNC Band Saws
Structural Miter-Cutting Saws
Automatic Band Saws

Visit our website at
www.cosen.com

COSEN MECHATRONICS CO., LTD.