

Top Bender[®] TB50[®] Classic

Rotary Draw Bender for Pipe, Tube and Profile Bending

Operator's Manual



WARNING!

BEFORE USE, BE SURE EVERYONE USING THIS MACHINE READS AND THOROUGHLY UNDERSTANDS ALL SAFETY AND OPERATING INSTRUCTIONS IN THIS MANUAL

Model TB50 Classic _____

Serial # _____

TB50® Classic Rotary Bender

Pipe, tube and profile bending machine

Congratulations on your purchase of an Ercolina® bending machine from CML USA, Inc. Ercolina® machines are designed and manufactured to deliver years of trouble-free bending performance. Please take a moment to complete and mail the warranty registration card. Doing so validates machine warranty period and ensures prompt service if needed. Thank you for selecting products from CML USA, Inc. Ercolina®.

Table of Contents

Important safety instructions	5
Special Instructions	6
Before you begin and general identification	7
TB50® features and specifications	8
Wiring instructions and general assembly and setup	9
Bending terminology and material selection	10
Mounting tooling and selecting bend speed	11-12
Ercolina® rotary draw tie bar assembly	13-14
Bender programming	15-16
Bending troubleshooting	17
Display errors, accessories and maintenance	18
Voltage troubleshooting, voltage test readings	19
Grounding and wiring schematics	20-21
Material length required for rotary bends in pipe (tube and pipe information)	22
Conversion Tables - mm to inches and inches to mm	23
Minimum distance between bends by center line radius, pipe and tube kits	24
Ercolina® tube, pipe, profile benders and angle rolls	25-26

CML USA Ercolina® reserves the right to make improvements and modifications to design without prior notice.

TERMS AND CONDITIONS OF SALE

1. Definitions. As used herein, the term "Quotation" means these terms and conditions and all specifications, blueprints, drawings and data attached hereto or supplied by CML USA, Inc. ("CML") hereunder; the term "End-User" means the ultimate user of the Goods; the term "Dealer" means an independent contractor of CML whom purchased the Goods from CML to sell to the End-User; and the term "Goods" means the goods, equipment, products, parts, services, labor, or other items or work provided for under this Quotation.

2. Mere Price Quotation. This Quotation is a mere price quotation and does not constitute an offer or contractual agreement for the sale of Goods between CML and the End-User. The End-User shall have no claim whatsoever against CML based on this Quotation. CML generally sells Goods only to Dealers, who sell Goods to End-Users. **Any contractual agreement for the sale of Goods between CML and the End-User must be in writing and signed by CML's president.** Prices, specifications and lead times provided in the Quotation are subject to change (without notice) prior to the time of actual sale of the Goods.

3. Terms of Quotation. This Quotation relates only to the specifically quoted Goods. The End-User and CML acknowledge and agree the terms and conditions hereof supersede and reject all other oral or written communications regarding the subject matter hereof. The terms and conditions hereof may be amended, altered or changed only through a written document signed by the End-User and CML's president.

THE FOLLOWING (OR SUBSTANTIALLY SIMILAR) PROVISIONS SHALL ONLY APPLY IN THE EVENT CML IN FACT PRODUCES OR PROVIDES ANY GOODS OR SAMPLES FOR OR TO THE END-USER:

4. End-User's Materials. All materials required by CML to test the operation of the Goods shall be furnished by the End-User (at its sole cost and expense). All materials and equipment furnished by the End-User for the construction, remodeling, or testing of Goods (or for any other purpose) shall be delivered to CML at no cost to CML, FOB CML's warehouse floor. The End-User shall bear the risk and cost of returning all such materials and equipment to the End-User. The End-User shall pay all applicable crating and delivery costs and expenses for samples and parts delivered to the End-User and, except as may be required for testing purposes, the End-User shall pay all costs and expenses pertaining to producing parts or samples requested by the End-User.

5. Tolerance and Variations. Except as specified by the End-User and expressly agreed to by CML (in writing), the Goods shall be produced in accordance with CML's standard business practices. All Goods (including, but not limited to, Goods produced to meet an exact specification) shall be subject to tolerances and variations consistent with good manufacturing practice in respect to dimensions, weight, section, chemistry and mechanical properties, the normal variations in surface and internal conditions and in quality, and to deviations from tolerances and variations consistent with practical testing and inspection methods.

6. Warranty. CML hereby disclaims any warranty regarding speed of production or output or economics of operation with respect to the Goods. If such matters are set forth or described in the specifications applicable to the Goods such statement or description shall be deemed to be an estimate only. Any warranties of CML with respect to the Goods shall be null, void and without effect if such Goods have been altered or repaired by persons or entities other than CML, unless otherwise agreed to (in writing) by CML. Notwithstanding any contrary provision contained herein, the warranties of CML hereunder shall become effective and valid only for one year from the date of the bill of lading issued by the carrier at the designated FOB point. **THE WARRANTIES ATTACHED TO THIS QUOTATION ARE CML'S CURRENT EXCLUSIVE WARRANTIES AND CML EXPRESSLY DISCLAIMS ALL OTHER WARRANTIES (WHETHER WRITTEN, ORAL, IMPLIED OR STATUTORY), INCLUDING (BUT NOT LIMITED TO) ANY WARRANTIES OR MERCHANTABILITY OR FITNESS FOR A PARTICULAR PURPOSE.** Any claim for breach of CML's warranties must be demonstrated to CML's satisfaction to have existed at the time of delivery of the Goods and shall be deemed waived by the End-User unless written notice of such claim is actually received by CML within twelve (12) months after CML has shipped the Goods (FOB, CML's Factory) to which such claim relates. CML's liability under this Quotation shall be expressly limited (at CML's option) to the replacement or repair of non-conforming or defective Goods or to the credit for the purchase price of non-conforming Goods. Prior to said repair, replacement, or credit, CML has the right to inspect the Goods claimed to be defective or non-conforming, and, if requested by CML, End-User shall return such Goods to CML at CML's direction and expense. No Goods are to be returned to CML without CML's prior written authorization. **THE REMEDIES SET FORTH HEREUNDER SHALL CONSTITUTE THE EXCLUSIVE REMEDIES AVAILABLE TO THE END-USER AND ARE IN LIEU OF ALL OTHER REMEDIES.**

7. Limitation of Liability. IN NO EVENT SHALL CML BE LIABLE FOR INCIDENTAL, INDIRECT, SPECIAL OR CONSEQUENTIAL DAMAGES RESULTING FROM THE FURNISHING, PERFORMANCE, OR USE OF THE GOODS SOLD HEREUNDER (IF AT ALL), WHETHER AS A RESULT OF BREACH OF CONTRACT, BREACH OF WARRANTY, THE NEGLIGENCE OF CML OR OTHERWISE. CML's liability under no circumstances will exceed the purchase price for the Goods for which liability is claimed.

8. Indemnification; Assumption of Risk. To the extent permitted by law, the End-User agrees to indemnify and hold CML (and its respective agents and employees) harmless from and against any and all liabilities, damages, losses, actions, causes of action, claims (including, but not limited to, claims of patent infringements), expenses, costs (including, but not limited to, attorney's fees), fines, penalties and any other expenses directly or indirectly arising from End-User's actual use or intended use of the Goods. The End-User agrees to assume all risk of loss or damage to person or property while on the premises of CML or of CML's related corporations. To the extent permitted by law, the End-User (on behalf of itself and all of its agents and employees) hereby releases and forever discharges CML (and its respective employees and agents) from any and all claims, demands, causes of action, liabilities, losses or damages resulting or arising from the End-User's presence (or the presence of the End-User's employees and agents) on the premises of CML. The End-User warrants to CML that the End-User has the authority to grant this release on behalf of the End-User's agents and employees.

9. Non-Waiver. No waiver, alteration or modification of any of the provisions hereof shall be binding on CML unless such waiver is expressed in writing by CML. Waiver by CML of any breach or default by End-User hereunder shall not be deemed a waiver by CML of any default or breach by End-User which may thereafter occur.

10. Assignment. CML reserves the right to subcontract all or any part of the work to be performed hereunder, without obtaining the consent of the End-User. No notice to the End-User of any subcontracting by CML is required. The rights and obligations of the End-User hereunder may not be assigned without the prior written consent of CML.

11. Revocation of Quotation. In addition to CML's other rights and remedies, CML may by written notice to the End-User revoke this quotation (in whole or in part) at any time and CML shall not be liable to the End-User for any losses, damages or expenses incurred by the End-User as a result of such revocation.

12. Governing Law; Jurisdiction; Venue. The laws of the State of Iowa shall govern all disputes, controversies, interpretive matters and litigation arising under this Quotation. PROPER AND EXCLUSIVE JURISDICTION AND VENUE for all disputes, controversies, interpretive matters and litigation arising hereunder (or otherwise between the parties) lies with the Iowa District Court located in Scott County, Iowa or the United States District Court for the Southern District of Iowa, Davenport Division. The End-User hereby submits to the personal jurisdiction of such courts.

13. Limitations for Suits. Any cause of action or claim arising out of or relating to CML's performance or failure to perform hereunder or the furnishing, performance, or use of the Goods hereunder must be commenced within one (1) year after the claim or cause of action has accrued.

WARRANTY

Warranty. Seller warrants to Buyer that the Goods reasonably conform to Buyer's specifications attached hereto or if none are attached, then such Goods shall reasonably conform to Seller's sample provided to Buyer, or if none is provided, then Seller's standard specifications in effect at the time of this Order (subject to the provision of tolerances and variations described above) and that such Goods are reasonable free from defects in material and workmanship under normal use and service. Seller's warranties hereunder shall not apply to items manufactured or produced or services provided by persons or entities other than Seller. Seller hereby disclaims any warranty regarding speed of production or output or economics of operation with respect to the Goods.

If such matters are set forth or described in the specifications applicable to the Goods such statement or description shall be deemed to be an estimate only. Buyer shall be responsible to test the Goods upon receipt; provided, however, that Seller shall be notified of any such testing and Seller has the right to be present at any such testing. Any warranties of Seller with respect to the Goods shall be null, void and without effect if such Goods have been altered or repaired by persons or entities other than Seller, unless otherwise agreed to (in writing) by Seller. Notwithstanding any contrary provision contained herein, the warranties of Seller hereunder shall become effective and valid only for one year from the date of the bill of lading issued by the carrier at the designated f.o.b. point. THE WARRANTIES SET FORTH IN THIS ORDER ARE SELLER'S EXCLUSIVE WARRANTIES AND SELLER EXPRESSLY DISCLAIMS ALL OTHER WARRANTIES (WHETHER WRITTEN, ORAL, IMPLIED OR STATUTORY), INCLUDING (BUT NOT LIMITED TO) ANY WARRANTIES OR MERCHANTABILITY OR FITNESS FOR A PARTICULAR PURPOSE. Any claim for breach of Seller's warranties must be demonstrated to Seller's satisfaction to have existed at the time of delivery of the Goods and shall be deemed waived by Buyer unless written notice of such claim is actually received by Seller within twelve (12) months after Seller has shipped the Goods (FOB, Seller's Factory) to which such claim relates. Seller's liability under this Order shall be expressly limited (at Seller's option) to the replacement or repair of non-conforming or defective Goods or to the credit for the purchase price of non-conforming Goods. Prior to said repair, replacement, or credit, Seller has the right to inspect the Goods claimed to be defective or non-conforming, and, if requested by Seller, Buyer shall return such Goods to Seller at Seller's direction and expense. No Goods are to be returned to Seller without Seller's prior written consent. THE REMEDIES SET FORTH HEREUNDER SHALL CONSTITUTE THE EXCLUSIVE REMEDIES AVAILABLE TO BUYER AND ARE IN LIEU OF ALL OTHER REMEDIES.

Important Safety Instructions



WARNING!

When using electric tools, basic safety precautions should always be followed to reduce the risk of fire, shock and personal injury.

- 1. Keep Work Area Clean**
Cluttered areas and benches invite injuries.
- 2. Consider Work Area Environment**
Do not expose power tools to rain.
Do not use the power tools in damp or wet locations.
Keep work area well lit.
Do not use a tool in presence of flammable liquids or gases.
- 3. Guard Against Electric Shock**
Prevent body contact with grounded surfaces. For example; pipes radiators, ranges, refrigerator enclosures.
- 4. Keep Children Away**
Do not let visitors contact tool or extension cord.
All visitors should be kept away from work area.
- 5. Store Idle Tools**
When not in use, tools should be stored in a dry and high or locked-up place out of reach of children.
- 6. Do Not Force Tool**
It will do the job better and safer at the rate for which it was intended.
- 7. Use The Right Tool**
Do not force small tool or attachment to do the job of a heavy-duty tool.
Do not use the tool for purpose not intended, for example; do not use a circular saw for cutting tree limbs or logs.
- 8. Dress Properly**
Do not wear loose clothing or jewelry; they can be caught in moving parts.
Rubber gloves and non-skid footwear are recommended.
- 9. Use Safety Glasses**
Also use face mask or dust mask if operation is dusty.
- 10. Do Not Abuse Electric Cord**
Never yank electrical cord.
Keep electric cord from heat, oil and sharp edges.
- 11. Do Not Overreach**
Maintain proper footing and balance at all times.
- 12. Maintain Tools With Care**
Keep clean for better and safer performance.
Follow instructions for lubricating and changing accessories.
Inspect tool cords periodically and if damaged, have repaired by authorized service facility.
Inspect electrical cords periodically and replace if damaged.
Keep handles dry and clean and free from oil and grease

13. Disconnect Tools

Disconnect machine from power source when not in use, before servicing and changing accessories.

14. Remove Adjusting Keys and Wrenches

Form a habit of checking to see that keys and adjusting wrenches are removed from machine before turning it on.

15. Avoid Unintentional Starting

Always disconnect from power source before moving.

16. Stay Alert

Watch what you are doing. Use common sense, do not operate tool when you are tired. (Do not use when taking medications that may cause drowsiness.)

17. Check Damaged Parts

Before further use of the machine, guard or other part that is damaged should be carefully checked to determine that it would operate and perform its intended function.

Check alignment of moving parts, binding of parts, breakage of parts mounting and any other conditions that may affect its operation. A guard or other part that is damaged should be properly repaired or replaced by an authorized service center. Do not use this machine if switches do not turn it on and off. Have defective switches replaced by authorized service center.

Special Instructions

1. Read and follow operators manual thoroughly. If you require an additional manual please contact CML USA Ercolina® at **563-391-7700** or email **info@ercolina-usa.com**.
2. Due to size and weight, it is recommended that qualified professionals transport, position and install the bending machine. Use proper equipment for installation including lift truck safety straps, chains binders and bars. Machine must be balanced evenly at all times.
3. Never place hands, finger gloves or clothing near rotation machine parts.
4. Always disconnect machine from power source before changing accessories.
5. Always use eye and hearing protection.
6. Never wear loose clothing, gloves or jewelry when working near machine.
7. Stand in a safe position when operating machine.
8. Always wear safety approved steel toe footwear.
9. Make provision for safe handling of heavy and/or awkward materials.
10. Use only proper tooling, keep tooling securely fastened.
11. Keep machine and tooling free and clear of chips and debris.
12. Keep all safety features functioning and working properly.
13. Do not alter or modify machine. Use only OEM approved parts and accessories.

Before you Begin

Inspect machine to be sure following equipment arrived and no damage occurred during shipment.

TB50® and Standard accessories

TB50	Top Bender® model 50
050A	40mm hex shaft
050B	50mm hex shaft (mounted on machine)
050D	Support bracket for counterbending die
050G	Hand wheel
050H	Foot pedal switch
	6mm Tee Handle/Allen

General Identification of Parts

1. Access panel
2. Power supply cord
3. Speed selector
4. Emergency stop
5. Programming keys
6. Control panel with display
7. Center former die
8. Hex shaft
9. Counterbending die
10. Counterbend die vise
11. Counterbend die hand wheel
12. Transportation handle
13. Main power switch
14. Foot pedal switch

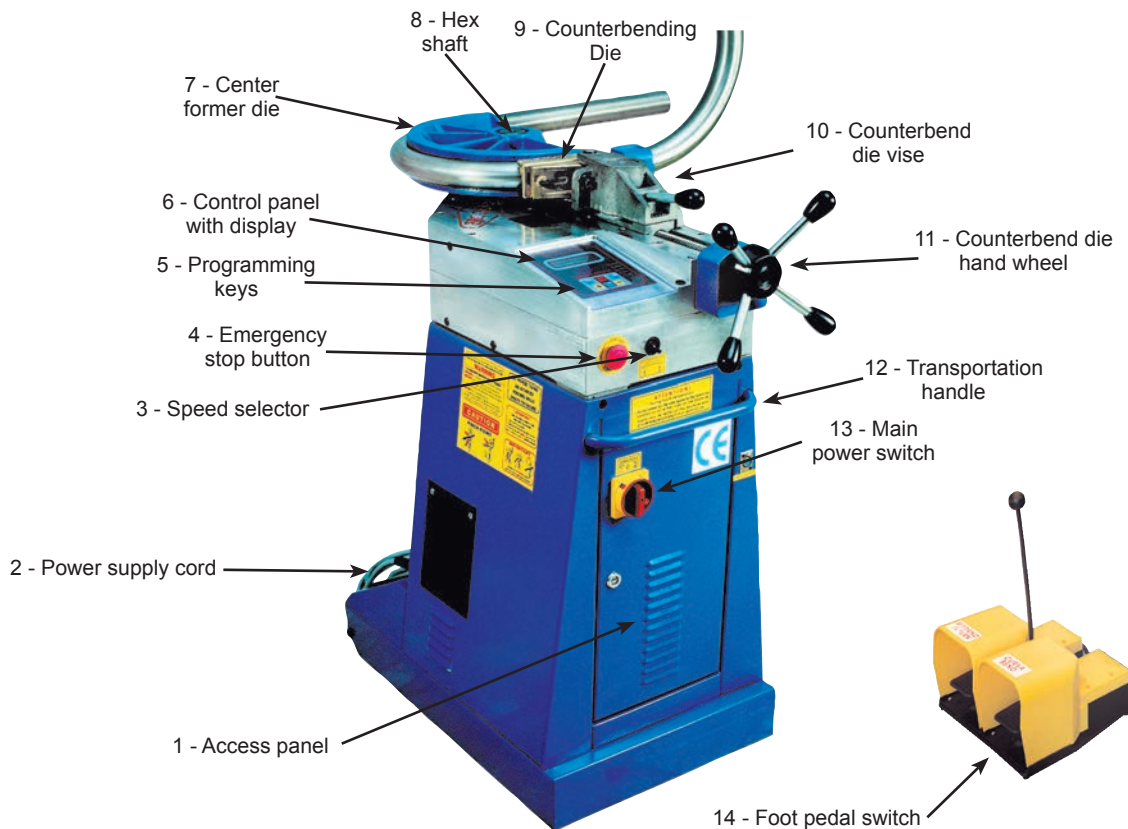

TB50® Features

- Bends material to 2½" OD
- Heavy-duty gear case with maximum 15" CLR
- Patented tooling system achieves CLR two times diameter without mandrel
- Low voltage 24V controls
- Operator friendly control panel memorizes (30) individual bend programs with (9) bends per program
- Programmable bend angles 0 to 180°
- Adjustable material springback for bend accuracy
- Two bending speeds for optimum bending results
- Bends to 90° in five seconds
- Remote foot pedal for hands free operation
- Patented swing away vise system and hex mounted tooling increase productivity
- Overload protection controls
- Standard multiple language capability
- Transportation wheels and lift handle built into base cabinet
- Tool free tooling changes with multiple CLR available for each diameter
- Accepts Ercolina® two axis A40/P positioner table
- Comprehensive (1) one-year warranty

Machine Capacities

Material	Maximum Diameter	Maximum Thickness
Pipe	2" ID	Schedule 40
Mild steel tube	2½"	.125
Soft brass	2½"	.140
Stainless steel	2½"	.120
Welded furniture tube	2½"	.125
ST 35 hydraulic steel	2½"	.125
304L hydraulic stainless	2½"	.095
Hard copper and aluminum	2½"	.187
Round solids	1½"	--
Rectangular solids	¾" x 2 ¾"	--
Rectangular tube	1¼" x 2½"	.118
Square tube	2½" x 2½"	.083
Square solids	1¼" x 1¼"	--
Mild steel T	2½" x 2½"	.236
Mild steel C channel	2" x 1"	.200

All capacities based on mild grade material using machine at low bending speed;
Heavy wall and high tensile materials reduce machine capacity.

Dimensions and Specifications

Height x Length x Width	30" x 20" x 40"
Bending speed	1 or 2 RPM
Motor	220 or 440 volt (specified at time of order)
Minimum and Maximum CLR	¾"-12"
Bending angle range	0 to 180°
Weight	374 lbs.

Wiring Instructions and Connections

Attention! Standard TB50® machines ship 220V 3ph (**440V must be specified upon order**). Have a qualified electrician connect your machine according to the following instructions. **Note:** CML USA Ercolina® is not responsible for damage that may occur from improper installation.

1. Determine location of machine installation.
2. Measure incoming line voltage at power source.
3. Confirm line voltage matches machine's voltage rating.
4. TB50®'s are equipped with two multi-tap transformers (TR1 and TR2).
Voltage taps on (TR1) and (TR2) transformers must be set to match incoming line voltage.
5. Access front panel to make necessary adjustments to electrical controls.
6. Complete wiring installation, close and lock cabinet door.
(**Note to electrician:** When connecting machine to Delta power supply, connect highleg to wire #52 at machine. See diagram.)

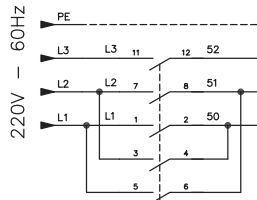

7. Release emergency stop switch and rotate main power switch to "ON" position.
If panel displays "rotation error", turn machine power "OFF", rotate power switch in opposite direction to automatically change phasing.

General Assembly and Setup

- Connecting Foot Pedal -

Insert male end of DIN plug connector into female socket on front of base cabinet.

- Select Operating Language -

Machine's preset language is "English". Alternative languages are available for use.

To select other languages:

1. Turn main power switch (OFF)
2. Depress and hold (+) , (-) and (Enter) keys simultaneously
3. Turn main power switch to (ON) position
4. Select desired language using (+) key
5. Confirm selection by depressing (Enter) key

- Setting Hex Shaft to "0" Position -

Before mounting tooling, hex shaft "0" mark must be aligned with "0" stamped on main casting (see FIG. A on page 10).

If hex shaft alignment is required:

1. Turn main power switch (OFF)
2. Depress and hold (Bend) or (Return) keys on touch pad
3. Turn main power switch (ON)
4. Release key - machine will display (Shaft reset mode)
5. Depress (Bend)-counterclockwise or (Return)-clockwise keys to align hex shaft "0" mark with "0" stamped on main casting
6. Depress (Enter) key to store position

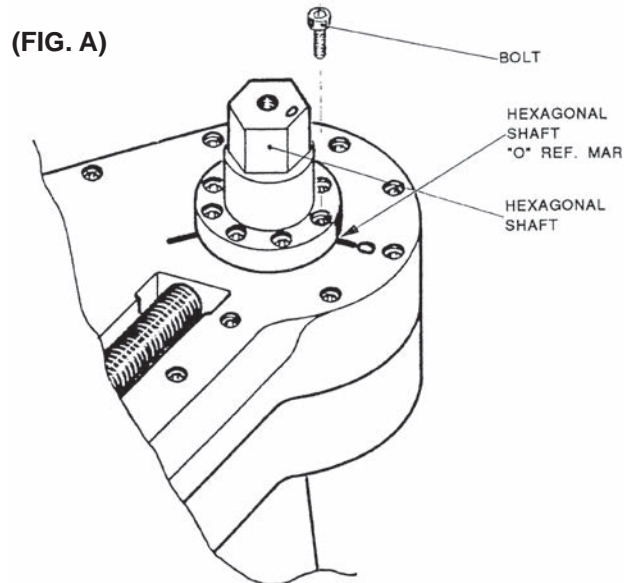

- Changing Hex Shafts -

TB50® ships with 50mm hex shaft installed. Smaller tooling requires using 40mm hex shaft.

To interchange shafts:

1. Remove (8) 8 x 1.25 x 25mm SHCS securing hex shaft to machine
2. Remove existing hex shaft - install desired shaft (**Note:** Only one fitting position is possible)
3. Replace and securely tighten (8) SHCS

- Hand wheel installation -

Place hand wheel on hex head of lead screw. Hand wheel is used for positioning (X) axis and setting counterbend die pressure.

Bending Terminology

OD: Outside diameter of pipe or tube

ID: Inside diameter of pipe or tube

Wall Thickness: Pipe wall thickness is measured in terms of schedule (i.e. 5, 10, 40). Tube wall thickness is measured in terms of gauge (i.e. 16 gauge = .065).

Center Line Radius (CLR): Exact measured distance from centerline of tooling to centerline of material's neutral axis

Degree of Bend: Number of degrees required in a bend - right angle requires 90° of bend

Springback: A material's tendency to return to its original shape after bending

Ovality: Amount of distortion created in the cross section of pipe or tube from a normal round shape

Tangent Points: The two points at which bend starts and ends

Distance between bends: Straight section between two tangent points of bends

Tensile Strength: Point at which material is stretched beyond yield strength

Material Selection

Before bending any material you should know the following:

1. Outside and inside physical dimensions
2. Wall thickness
3. ASTM specifications
4. Desired CLR radius
5. Degree of bend
6. Minimum distance between bends

- Proper Tooling Selection -

Refer to CML USA Ercolina® master catalog for recommended centerline bend radius for the material to be bent. If your application requires a CLR or profile that is not shown CML USA Ercolina® can quote special tooling on request. As a general guide when bending tubing and pipe, the heavier the wall thickness the tighter the centerline radius can be without distortion. Therefore when bending thin wall tube select the largest possible radius for best bend quality. Material requiring CLR smaller than two times the diameter should be bent with a mandrel support, consult CML USA Ercolina® for more details. The standard counterbending dies are brass to accommodate a variety of material without conflict. Counterbending dies are also available in steel for heavy usage or polymer for applications in which the work piece finish is a factor. **Note:** When bending heavy wall material or solids a special roller style counterbending die is recommended.

- Installing counterbending die vise -

Place vise assembly on tool post of counterbending die axis, vise assembly should pivot counterclockwise when mounted.

- Mounting center former -

Ercolina® center formers are manufactured with an offset hex design ensuring proper installation. When mounted the center former's gripper arm should face right side of machine.

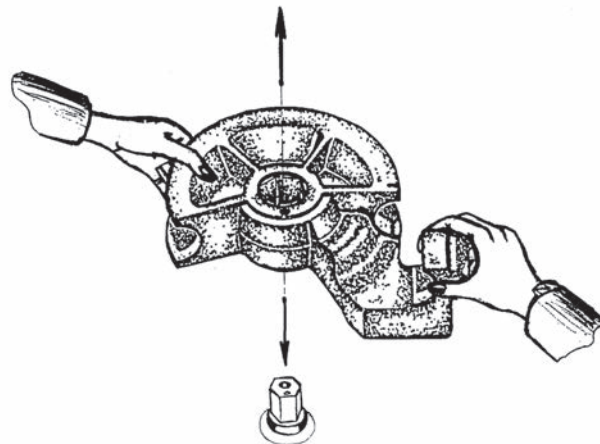

- Mounting counterbending die -

Ercolina® counterbending dies are designed for quick installation and removal. Insert male dovetail located on back of counterbend die into slot on counterbending die vise. Hold die firmly against vise, depress and rotate black knob clockwise securing die onto vise bracket. Installed properly, the "Ercolina®" logo will be facing the operator (see figure). **Note:** When bending heavy wall profiles and solids, standard counterbend die and vise must be removed and replaced with a roller counterbend die. **Attention: Failure to use roller style die on heavy profiles may result in machine damage.** (See Mounting "roller" counterbending die instructions.)

Note: Counterbending dies are wear items - Replace as necessary to ensure bend quality. Counterbending die should never contact center former when material is in former and tooling is in starting position.

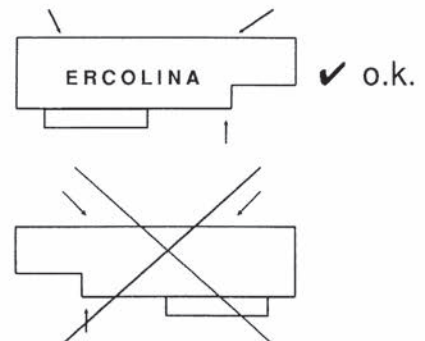

- Counterbending die lubrication -

For best results counterbending dies should be kept lubricated with Ercolina® spray grease - Part # 810. Proper lubrication extends counterbend die life and improves bend quality.

- Loading work piece -

1. Slide work piece into gripper arm and groove of center former
2. Using hand wheel advance counterbending die forward until material rests securely between former and die (see FIG. 1).
3. Properly adjusted vise and counterbending die assembly should be perpendicular to work piece and swing freely counterclockwise to release work piece (see FIG. 2).

Note: If vise assembly pivots away from material at beginning of bend, reduce pressure on vise. Proper counterbending die adjustment ensures satisfactory bends.

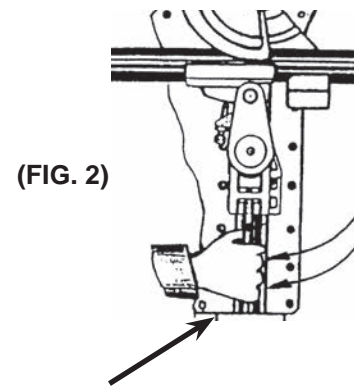
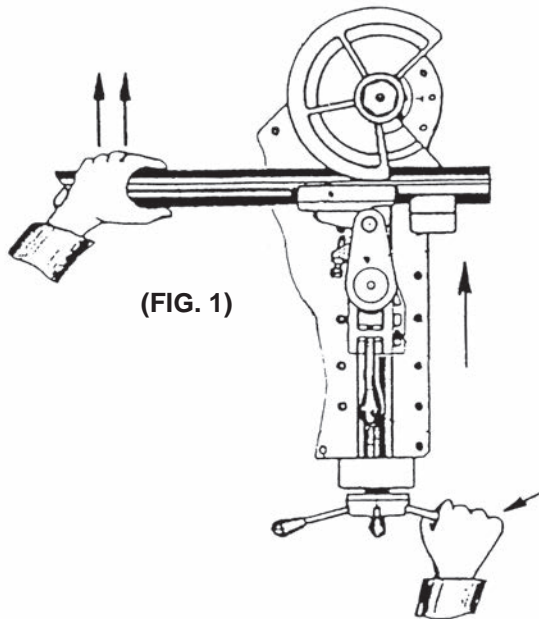

- Setting counterbending die axis to "0" at control panel -

Depress (Enter) until display reads "0.000". **Note:** Bender will not cycle if counterbending die axis is not at "0" position.

- Selecting proper bending speed -

TB50® has a two-speed gearbox. As a general rule tubes $\frac{1}{4}$ " to $1\frac{3}{8}$ " diameter can be bent at (speed 2), when bending larger diameter profiles (speed 1) should be used.



ERCOLINA[®] ROTARY DRAW TIE BAR ACCESSORY

Mega Bender[®] 030, TB60, TB050 Classic, 050KD, and SB48



Hex Drive Center Pivot

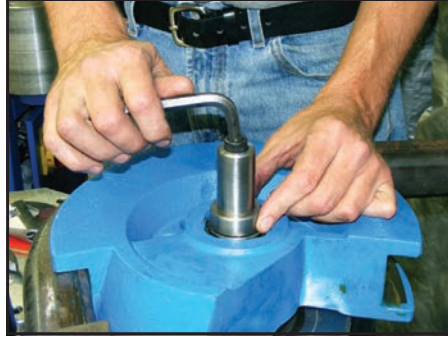

Securing Centerformer Pivot Shaft



Saddle Block Mounting Screw



Securing Saddle Block

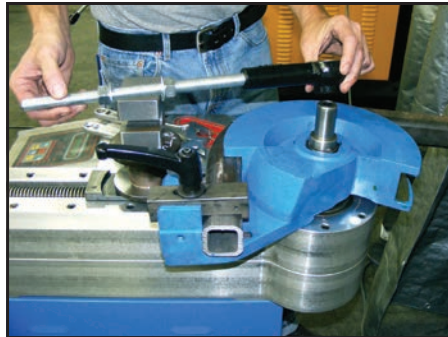

Installing Tie Bar

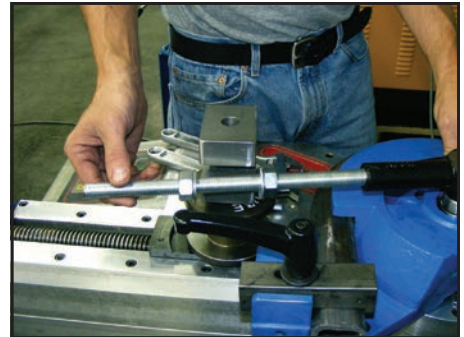

Side Loading Tie Bar

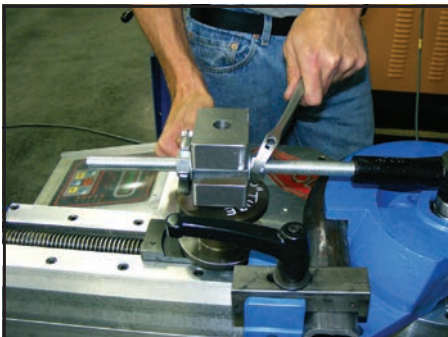

Tie Bar Nuts

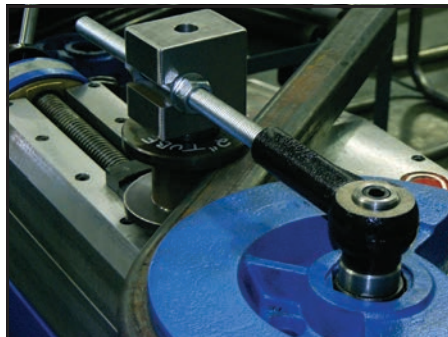

Tie Bar Assembly Mounted

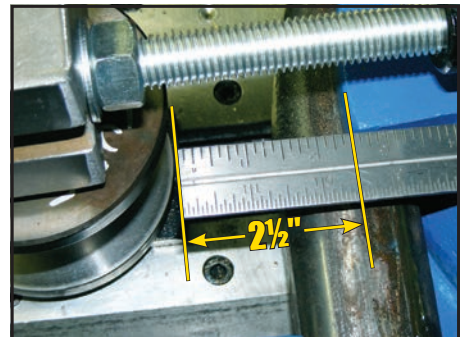

Minimum Distance (fig. 1)



Tie Bar Assembly



Speed Selector



PW Reading

- Mounting “roller” counterbending die -

When bending heavy wall profiles or solid materials a roller counterbending die must be used. Remove counterbend die vise assembly and place roller die onto machine tool post. With material in center former advance roller die inward until material rests firmly between former and roller. Retract roller die approximately 2½” from material (refer to fig. 1 on page 13). Warning: **Never use roller die flush against material – doing so will damage machine.**

Special Application Tooling – Part# 030TIEBAR

- Never bend material exceeding machine specifications (i.e. high tensile, stainless, heavy profile or solid). Contact factory for machine capacity before bending.
- Always use lowest rpm setting. Reset tool shaft position – “C” axis 10° above “0” home – to avoid center former interference with machine case.
- Always use roller-style counterbending die.
- Mounting the roller-style counterbending die (Heavy Profiles or Solids). Heavy wall profiles and solid materials require a roller counterbending die. Remove the standard counterbend die vise assembly and slide roller onto vise mounting post. With material in former move roller die inward until material rests firmly between former and roller. **Back roller die off approximately 2½”.**



Warning: **Never use roller die firmly against the material.**

- Always use tie bar. Refer to mounting instructions. Tighten hex nuts neutrally, neither pushing nor pulling against tie bar assembly. Rotate hand wheel counter clockwise to remove play from counterbending vise screw.
- Always use lubrication on roller-style counterbending die and tool post.
- When bending – monitor machine display for PW or Amp reading. Never exceed 1200 PW/12 Amp.

Bender Programming

TB50® machines have (30) ten bending programs 0-9. Each program can store (9) nine individual bends.

- Control panel keys and their functions -

(Return)	Returns hex shaft to "0" position
(Bend)	Moves hex shaft to desired bend angle
(Cursor)	Used for editing program, bend angle and springback value
(+)	Increases values when editing
(-)	Decreases values when editing

- Important touch key functions -

(Enter) and (-) (When in "0" position before bend cycle)	Accesses "Data entry mode"
(Enter) and (Bend) or (Return)	Resets counterbending die axis to "0"
(Enter) , (+) and (-) (When turning main power on)	Enters "Language selection mode"
(Bend) or (Return) (When turning main power on)	Enters "Shaft reset mode"
(Cursor) (Any time during bending cycle)	Enters "Program edit mode"

- Data entry mode -

1. Depress **(Cursor)** key
2. Display reads "Data entry yes or no"
3. Depress **(+)** = yes or **(-)** = no



- Selecting program number -

Depress **(+)** until desired program is reached 0-9

- Erasing previous Information -

- Depress **(-)** hold for five seconds - process erases all previously stored information in program. Do not use process for simple editing.
- Display reads "Program No.1 12 .000" or similar

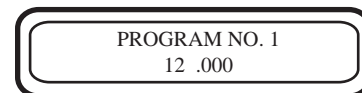

- Enter first bend angle -

- Depress **(+)** or **(-)** to enter desired bend angle. **Note:** While in programming mode, **(Bend)** = 45°, **(Return)** = 135° and **(Cursor)** = 90° keys help quickly move closer to desired angle
- Depress **(Enter)** to store angle

- Editing bend angles -

- Depress **(+)** to enter desired bend angle, **(-)** can be used should you go past desired angle
- Depress **(Enter)** to store angle

- Exiting data entry mode -

- Depress **(Enter)**
- Display reads "End of Date Entry"



- Returning to working display -

- Depress **(Enter)**
- Display Shows currently selected program and reads "Forward C counterbending die"

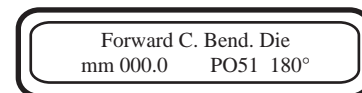

- Initial springback setup -

1. With previous steps completed -
2. Initiate bend cycle by depressing **(Bend)** key or foot pedal switch
3. Stop bend cycle when material begins to deflect (see FIG. 1)
4. Observe degree reading on control panel.
5. Depress **(Enter)** to insert displayed springback value into program (**Note:** Springback value can be edited later if needed). Springback must be set for each angle within program.

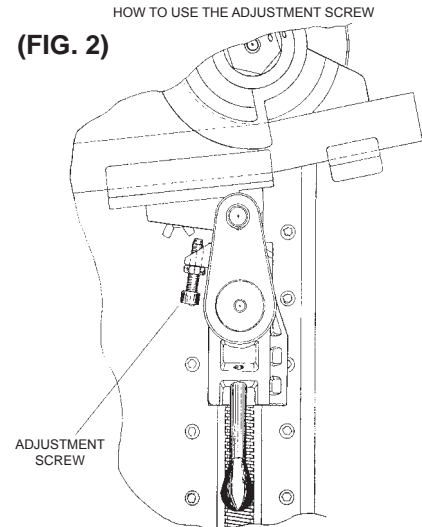
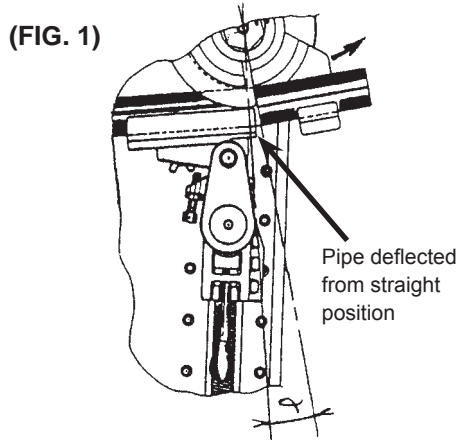

- Adjusting counterbending die support screw -

Using Allen wrench, turn adjustment screw until contacting back side of vise. Secure screw with locking jam nut (see FIG. 2). Adjustment screw affects quality of bend and must be set for each material.

- Finishing bend -

Depress and hold **(Bend)** key or foot pedal completing bend cycle (see FIG. 3)

- Return center former to "0" position -

Depress and hold **(Return)** key or foot pedal until bender returns to "0" home position (see FIG. 4). **Note:** Display will automatically advance to next bend within program.

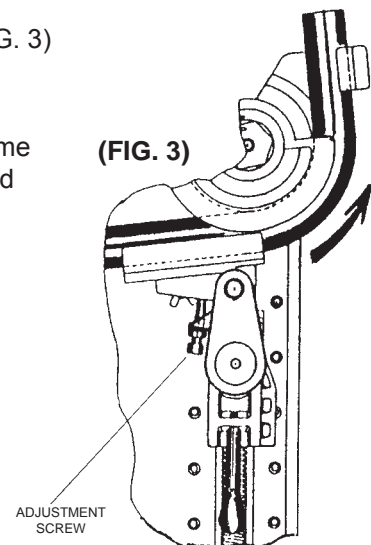
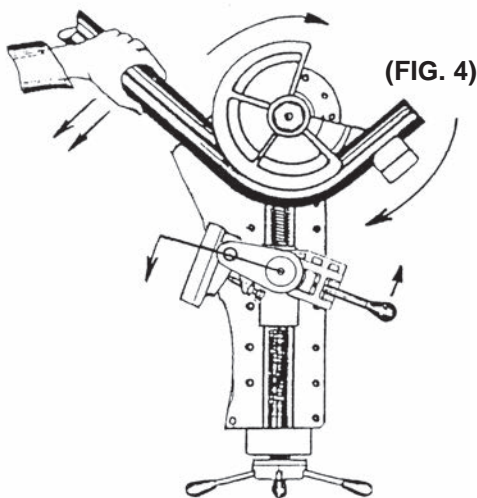

- Editing bend angles and springback values -

Bend angles and springback values can be edited at any time during a bend cycle. Depress and release **(Cursor)** key - cursor will flash in the springback field. **(+)** and **(-)** keys can then be used to edit settings. Depress **(Enter)** key to store changes.

Bending Troubleshooting

Problem	Probable Cause	Solution
Material wrinkles or deforms	Counterbend die pressure incorrect	Increase counter die pressure
	Radii too small for profile	Increase CLR of tooling
Tube slips	Poor quality tubing	Confirm tubing measurements and replace with quality material
	Counter bend die pressure is too low	Increase die pressure tension
Material cracks or breaks	Material quality poor	Confirm material composition with mill certifications
Poor bend quality	Material quality poor	Replace material
	CLR too small for profile	Increase tooling CLR
	Improper tooling adjustment	Reset counterbend die pressure
Work piece ends are oval or deformed	Too much pressure on die	Decrease die pressure, change adjustment screw setting (see fig. below)
Machine overloads	Material exceeds machine's capacity	Reduce material size or wall thickness
	Large material on high speed	Use low speed (speed 1)
Counterbend die wears prematurely	Excessive pressure on counterbend die	Decrease counterbend die pressure
	Lack of lubrication	Use Ercolina® bending lubricant
	Material dirty or rusted	Replace material or clean surface
Tube has marks	Poor tube quality	Replace material
	Tooling not ordered for material	Consult factory

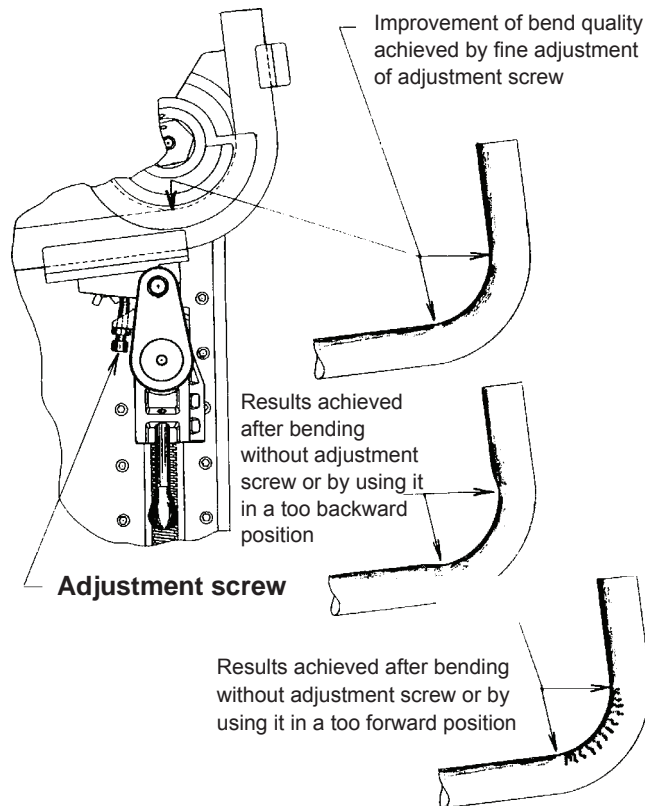

Table of Display Errors

Error Message	Possible Cause	Solution
High Tension	High incoming voltage	Reduce voltage
86	Missing phase	Check plug connections and fuses
86	Faulty TV transformer	Check incoming voltage/replace TV transformer
87 or 88	Missing phase	Check plug and 1A1 connections
87	Faulty TA	Check phase on 55 and 51 and then 55A and 50
87 or 88	"c" axis beyond 210 degrees	Reset hex shaft
88	Emergency switch depressed	Release emergency switch
88	Faulty "c" axis encoder	Check control card connections, check encoder star wheel for damage and tightness. Clean with air if dirty
88 when pedal is depressed	Faulty TR1 or rectifier	Check outlets 40-42 for 100 volts ac Check outlets 46-45 for 110 volts dc
Over load light "ON"	Machine in overload	Switch off and on and refer to capacity chart
Over load light "ON"	Faulty motor	Check motor and connections
Warning light "ON"	Emergency button is depressed	Release the emergency switch
Warning light "ON"	Motor safety switch is faulty	Ensure switch is on, check incoming and outgoing power
Overload light "ON"	Faulty "c" axis encoder	Check encoder and connections
Display shows incorrect rotation	Faulty "c" axis encoder	Replace

- TB50® Accessories -

- A40/P** - Two axis positioning table
- O50M** - Mechanical tube and pipe positioner
- O51** - Folding/Bending attachment
- O50E** - Counterbending die support bracket for radii 225mm
- O50I** - 3/8" - 2 1/2"
- O50J** - 2 1/2" - 3"
- 810** - One 12-oz can of Ercolina® Spray Grease
- 811** - 9pc case of Ercolina® Spray Grease
- Polymer counterbending die - quote on request

- Routine Maintenance -

- Keep machine clean and free of grease and debris
- Using supplied grease gun, lubricate gearbox at zirts every 40 hours of use (see figure)
- Replace worn power cords or broken switches
- Clean encoder with electrical contact cleaner or canned air spray
- Any repair or replacement of internal or external parts of machine must be made only by personnel trained/authorized by Ercolina®
- Replace worn tooling
- Ercolina® reserves the right not to supply accessories or spare parts if machine has been modified

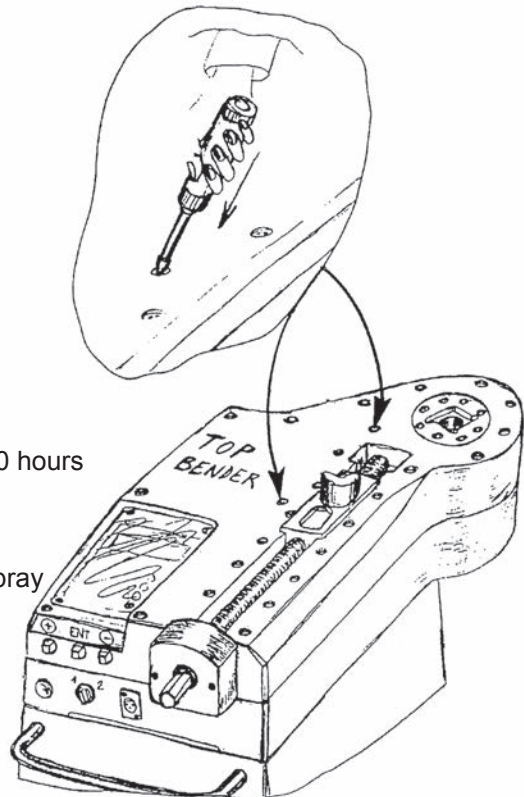

Top Bender® Voltage Troubleshooting

Voltage Test Readings

Main switch:	Outlets 52-50	Voltage = _____	Power Supply Voltage
	Outlets 52-50	Voltage = _____	Power Supply Voltage
Main Transformer:	Outlets 3-1	Voltage = _____	Power Supply Voltage
	Outlets 40-41	Voltage = _____	+/- 100 VAC
	Outlets 6-2	Voltage = _____	24 VAC
	Outlets 45-46	Voltage = _____	110 DC (only in bend/return mode motor circuit "OFF" position)
Board Transformer:	Outlets 3-14	Voltage = _____	Power Supply Voltage
	Outlets 84-85	Voltage = _____	11 VAC
Motor Control Switch:	Outlets 50-52	Voltage = _____	Power Supply Voltage
	Outlets 51-52	Voltage = _____	Power Supply Voltage
	Outlets 53-55A	Voltage = _____	Power Supply Voltage
	Outlets 54-55A	Voltage = _____	Power Supply Voltage
Panel Control Switch:	Outlets 50-51	Voltage = _____	Power Supply Voltage
	Outlets 1-3	Voltage = _____	Power Supply Voltage

Actual metered voltage at wall service= _____

Voltage setting on main transformer = _____

Voltage setting on board transformer = _____

Electrical Schematic (220V) (cont.)

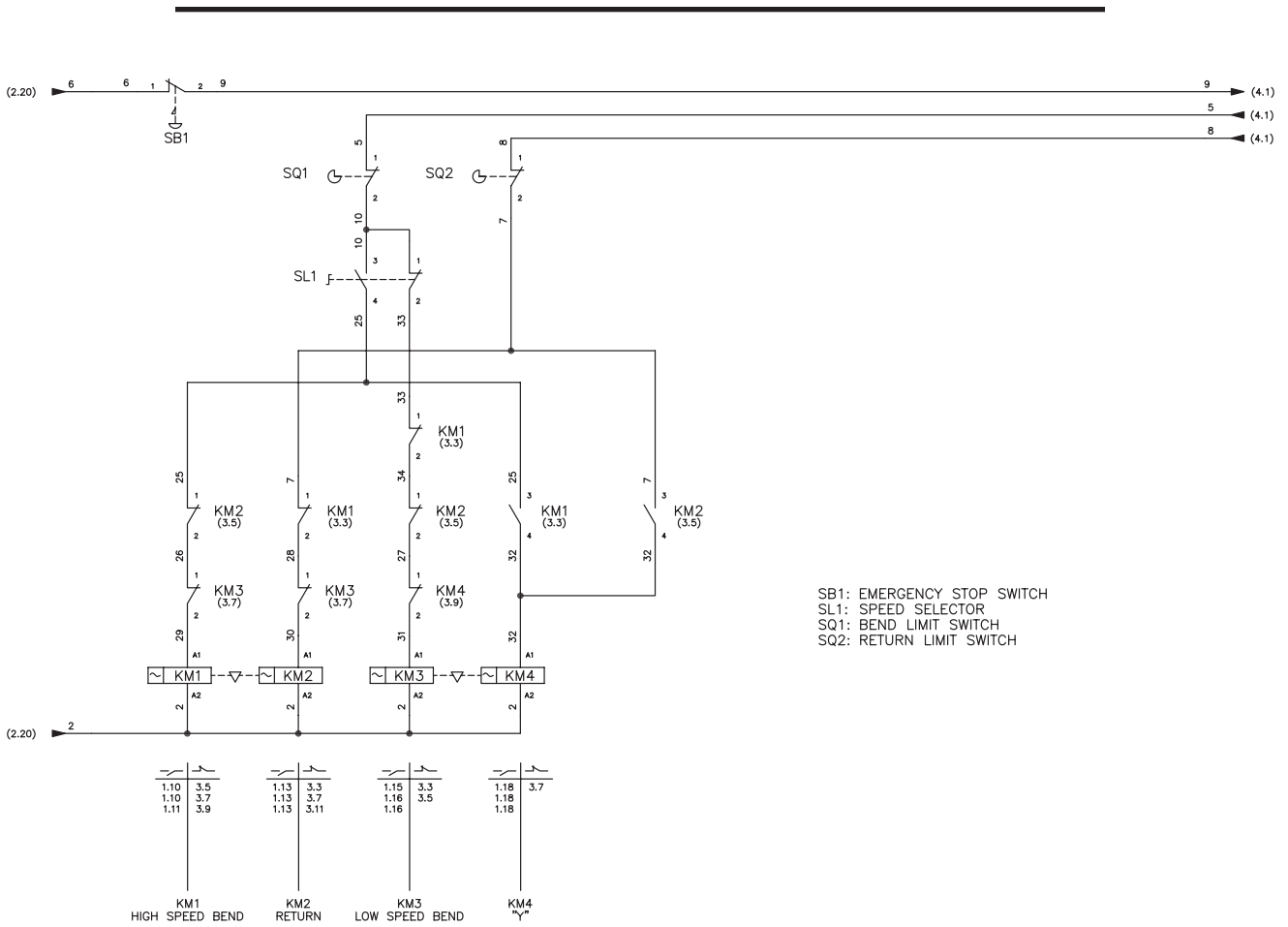
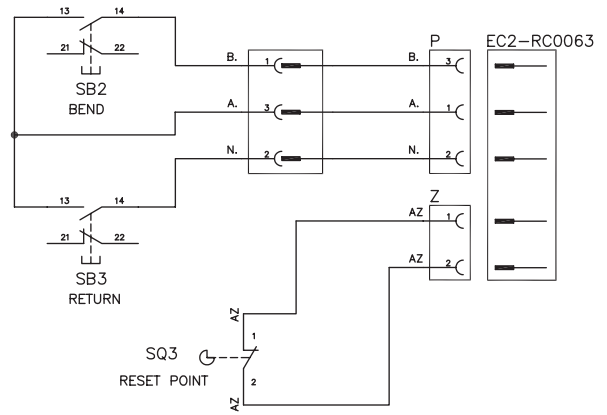
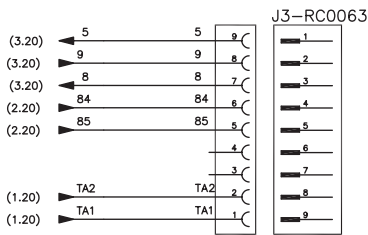
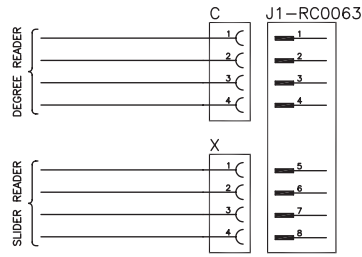

Material Length Required for Rotary Bends in Pipe

“Guideline for material consumption”

Bend Angle	½ with 1.8 CLR	¾ with 2.2 CLR	1 with 2.6 CLR	1¼ with 3.5 CLR	1½ with 3.9 CLR	2 with 5.9 CLR
5	.16	.19	.23	.31	.34	.52
10	.31	.38	.45	.61	.68	1.03
15	.47	.58	.68	.92	1.02	1.55
20	.63	.77	.91	1.22	1.36	2.07
25	.79	.96	1.13	1.53	1.70	2.58
30	.94	1.15	1.36	1.83	2.04	3.10
35	1.10	1.34	1.59	2.14	2.38	3.61
40	1.26	1.54	1.82	2.44	2.72	4.13
45	1.41	1.73	2.04	2.75	3.06	4.65
50	1.57	1.92	2.27	3.05	3.40	5.16
55	1.73	2.11	2.50	3.36	3.74	5.68
60	1.88	2.30	2.72	3.67	4.08	6.20
65	2.04	2.50	2.95	3.97	4.42	6.71
70	2.20	2.69	3.18	4.28	4.76	7.23
75	2.36	2.88	3.40	4.58	5.11	7.74
80	2.51	3.07	3.63	4.89	5.45	8.26
85	2.67	3.26	3.86	5.19	5.79	8.78
90	2.83	3.46	4.08	5.50	6.13	9.29
100	3.14	3.84	4.54	6.11	6.81	10.33
110	3.46	4.22	4.99	6.72	7.49	11.36
120	3.77	4.61	5.45	7.33	8.17	12.39
130	4.08	4.99	5.90	7.94	8.85	13.42
140	4.40	5.38	6.35	8.55	9.53	14.46
150	4.71	5.76	6.81	9.16	10.21	15.49
160	5.03	6.14	7.26	9.77	10.89	16.52
170	5.34	6.53	7.71	10.38	11.57	17.55
180	5.65	6.91	8.17	11.00	12.25	18.59

To calculate total pipe length, add distance from end of pipe to the first bend, plus first bend arc length, plus distance to second bend

Commercial pipe and wall thickness

Tube gauge	Equivalent in inches	Nominal Size	Outside Dia.	Schedule 5	Schedule 10	Schedule 40	Schedule 80	Schedule 160	XX Strong
10	.134	⅛	.405		.049	.068	.095		
11	.120	¼	.540		.065	.088	.119		
12	.109	⅜	.675		.065	.091	.126		
13	.095	½	.840	.065	.083	.109	.147	.188	.294
14	.083	¾	1.050	.065	.083	.113	.154	.219	.308
16	.065	1	1.315	.065	.109	.133	.179	.250	.358
18	.049	1¼	1.660	.065	.109	.140	.191	.250	.382
20	.035	1½	1.900	.065	.109	.145	.200	.281	.400
		2	2.375	.065	.109	.154	.218	.344	.436
		2½	2.875	.083	.120	.203	.276	.375	.552
		3	3.500	.083	.120	.216	.300	.438	.600

Millimeters to Inches Conversion

MM	Inches Decimal	MM	Inches Decimal	MM	Inches Decimal	MM	Inches Decimal
1	0.039	29	1.141	57	2.244	85	3.347
2	0.079	30	1.181	58	2.284	86	3.386
3	0.118	31	1.221	59	2.323	87	3.425
4	0.158	32	1.260	60	2.362	88	3.465
5	0.197	33	1.299	61	2.402	89	3.504
6	0.236	34	1.339	62	2.441	90	3.543
7	0.276	35	1.378	63	2.480	91	3.583
8	0.315	36	1.417	64	2.520	92	3.622
9	0.354	37	1.457	65	2.559	93	3.661
10	0.394	38	1.496	66	2.598	94	3.701
11	0.433	39	1.535	67	2.638	95	3.740
12	0.472	40	1.575	68	2.677	96	3.780
13	0.512	41	1.614	69	2.717	97	3.819
14	0.551	42	1.654	70	2.756	98	3.858
15	0.591	43	1.693	71	2.795	99	3.898
16	0.630	44	1.732	72	2.835	100	3.937
17	0.669	45	1.772	73	2.874	110	4.331
18	0.709	46	1.811	74	2.913	120	4.724
19	0.748	47	1.850	75	2.953	130	5.118
20	0.787	48	1.890	76	2.992	140	5.512
21	0.827	49	1.929	77	3.032	150	5.906
22	0.866	50	1.969	78	3.071	160	6.299
23	0.906	51	2.008	79	3.110	170	6.693
24	0.945	52	2.047	80	3.150	180	7.087
25	0.984	53	2.087	81	3.189	190	7.480
26	1.024	54	2.126	82	3.228	200	7.874
27	1.063	55	2.165	83	3.268	250	9.843
28	1.102	56	2.205	84	3.307	300	11.811

Inches to Millimeters Conversion

Fractions	Decimal	MM	Fractions	Decimal	MM
1/64	0.016	0.397	33/64	0.516	13.096
1/32	0.031	0.794	17/32	0.531	13.493
3/64	0.047	1.191	35/64	0.547	13.890
1/16	0.063	1.588	9/16	0.563	14.287
5/64	0.078	1.984	37/64	0.578	14.684
3/32	0.094	2.381	19/32	0.594	15.081
7/64	0.109	2.778	39/64	0.609	15.478
1/8	0.125	3.175	5/8	0.625	15.874
9/64	0.141	3.572	41/64	0.641	16.271
5/32	0.156	3.969	21/32	0.656	16.668
11/64	0.172	4.366	43/64	0.672	17.065
3/16	0.188	4.763	11/16	0.688	17.462
13/64	0.203	5.159	45/64	0.703	17.859
7/32	0.219	5.556	23/32	0.719	18.256
15/64	0.234	5.953	47/64	0.734	18.653
1/4	0.250	6.350	3/4	0.750	19.049
17/64	0.266	6.744	49/64	0.766	19.446
9/32	0.281	7.144	25/32	0.781	19.843
19/64	0.297	7.541	51/64	0.797	20.240
5/16	0.313	7.938	13/16	0.813	20.637
21/64	0.328	8.334	53/64	0.828	21.034
11/32	0.344	8.731	27/32	0.844	21.431
23/64	0.360	9.128	55/64	0.859	21.828
3/8	0.375	9.525	7/8	0.875	22.224
25/64	0.391	9.922	57/64	0.891	22.621
13/32	0.406	10.319	29/32	0.906	23.018
27/64	0.422	10.716	59/64	0.922	23.415
7/16	0.438	11.113	15/16	0.938	23.812
29/64	0.453	11.509	61/64	0.953	24.209
15/32	0.469	11.906	31/32	0.969	24.606
31/64	0.484	12.303	63/64	0.984	25.003
1/2	0.500	12.700	1	1.000	25.399

Minimum Distance Between Bends By Center Line Radius

Radius of Center Former		Minimum Distance Between Bends	
Inches	Metric	Inches	Metric
.394	10	NA	NA
.472	12	NA	NA
.591	15	NA	NA
.630	16	NA	NA
.709	18	NA	NA
.787	20	NA	NA
.945	24	NA	NA
1.023	26	NA	NA
1.102	28	NA	NA
1.181	30	NA	NA
1.259	32	NA	NA
1.417	36	2.362	60
1.811	46	3.149	80
2.204	56	3.740	95
2.637	67	3.937	100
3.228	82	3.937	100
3.543	90	4.330	110
3.937	100	4.330	110
4.133	105	4.330	110
4.409	112	4.330	110
4.724	120	5.511	140
5.118	130	5.511	140
5.708	145	5.905	150
6.692	170	5.905	150
7.283	185	5.905	150
7.480	190	5.905	150
8.858	225	5.905	150
10.236	260	6.299	160
11.811	300	6.299	160

TB50® with pipe kit					TB50® with tube kit				
Size	CLR	Min. Wall	Former part #	Counterbend #	Size	CLR	Min. Wall	Former part #	Counterbend #
½"	1.8	.109	153R046P0500	155P0500	¾"	2.6	.039	153R067T0750	154T0750
¾"	2.2	.113	153R056P0750	155P0750	⅞"	2.6	.039	153R067T0875	154T0875
1"	2.6	.133	153R067P1000	155P1000	1"	3.2	.039	153R082T1000	154T1000
1¼"	3.5	.140	153R090P1250	155P1250	1¼"	4.4	.039	153R112T1250	154T1250
1½"	3.9	.145	153R100P1500	155P1500	1½"	5.9	.047	153R150T1500	154T1500
2"	5.9	.154	153R150P2000	155P2000	1¾"	6.7	.059	153R170T1750	154T1750
					2"	7.5	.059	153R190T2000	154T2000

Pipe kit only # PIPEKIT1

Tube kit only # TUBEKIT1



Tube, Pipe and Profile Benders

Beware of Imitations

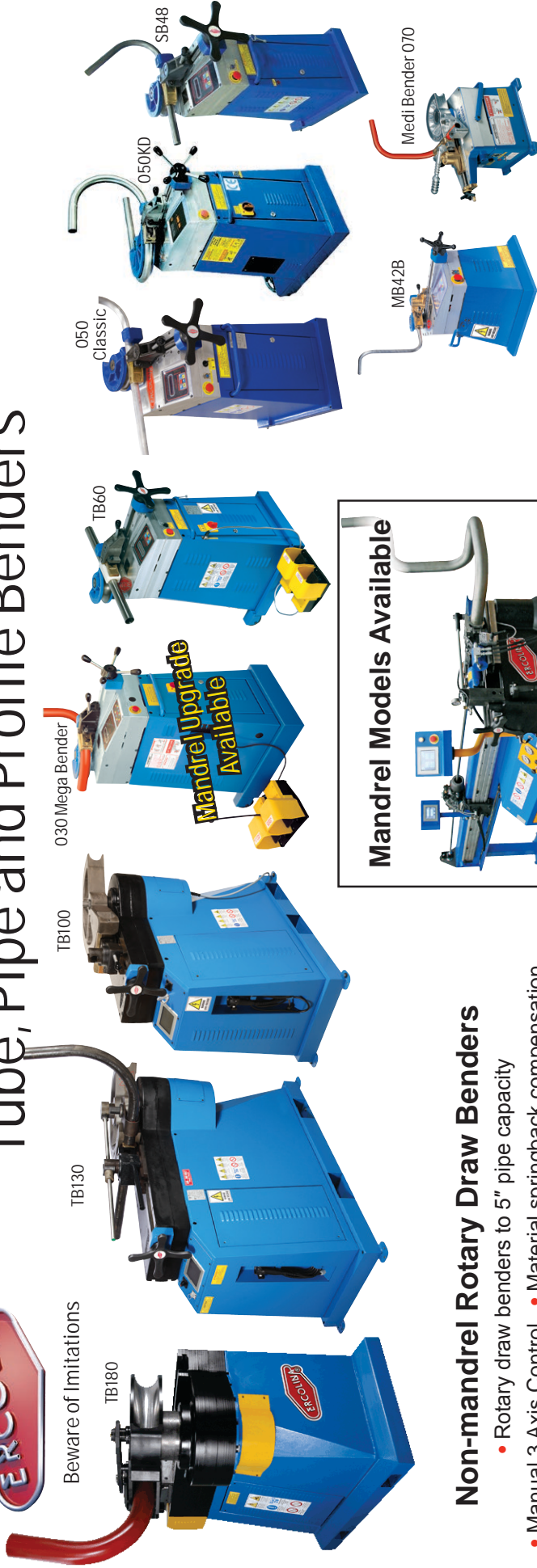

Ercolina®
DEMO VIDEOS
www.ercolina-usa.com

Non-mandrel Rotary Draw Benders

- Rotary draw benders to 5" pipe capacity
- Manual 3 Axis Control • Material springback compensation
- User friendly programmable controls
- All machines and tooling in "Stock"
- Sample bends upon request

Model	TB180	TB130	TB100	030 Mega Bender	TB60	050 Classic	050KD	SB48	MB42B	Medi Bender 070
Tube Capacity	6" - .120 wall	5"	4"	3"	2½"	2½"	2½"	2"	1½"	1½" - .065 wall
Pipe Capacity	6" Sch. 10	4" Sch. 40	3" Sch. 40	2½" Sch. 10	2" Sch. 40	2" Sch. 40	2" Sch. 40	1½" Sch. 40	1" Sch. 40	1" Sch. 10
Square Tube Capacity	4"	4"	3½"	2"	2"	2"	2"	1½"	1½"	¾"
Maximum "CLR"	39¼"	27½"	17"	15"	15"	11⅞"	11⅞"	8⅞"	7½"	6⅞"
Degree of Bend	0-210°	0-210°	0-210°	0-210°	0-210°	0-210°	0-210°	0-210°	0-210°	0-210°
Bending Speed "RPM"	Variable to 1	Variable to .75	Variable to 1.3	Variable .6 to 2.2	1.7 or 3.4	1.0 or 2.0	1.2	2	2	2.2
NC Programming	Touch Screen	Touch Screen	Touch Screen	Touchpad	Touchpad	Touch Pad	LED	Touchpad	Touchpad	LED
Number of Programs	Unlimited with USB	Unlimited with USB	Unlimited with USB	30	30	30	1	30	30	1
Voltage	440V/3ph	220V or 440V/3ph	220V or 440V/3ph	*220V or 440V/3ph	220V or 440V/3ph	220V or 440V/3ph	220V or 440V/3ph	120V or 220V/3ph	120V	120V

Note: *220V 1 phase model available. Consult CML USA Inc. Ercolina with application questions • All capacities based on mild grade materials; heavy wall and high tensile materials reduce machine capacity • Machines ordered voltage specific • Consult factory for production applications and machine duty cycles.

"40 Years Excellence in Quality, Support and Service"

Angle Rolls – Section Benders

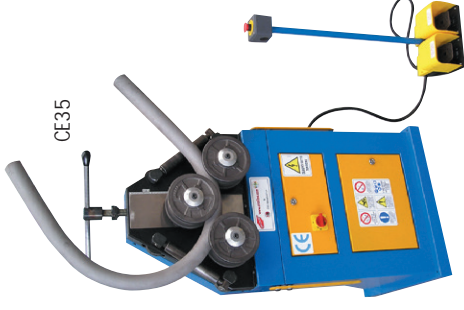
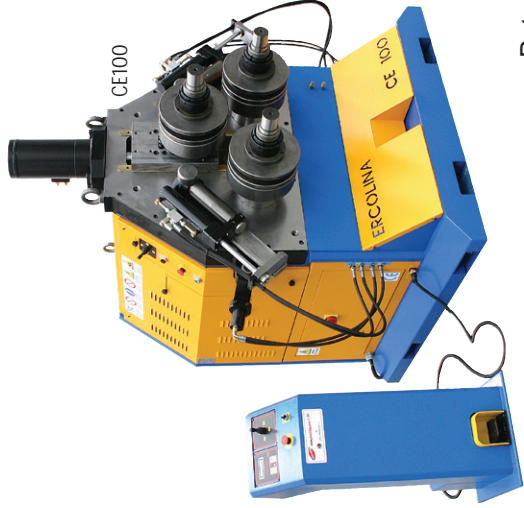

- Universal tooling set included • Vertical or horizontal positioning
- Patented by Ercolina® simultaneous downfeed and roll movement minimizes deformation

Model	CE100H3	CE70H3	CE50H3	CE40H3	CE40MR3	CE35
Tube Capacity	6"	4"	3"	2½"	2½"	2"
Pipe Capacity	4" Sch 40	3" Sch 40	2½" Sch 40	2" Sch 40	2" Sch 40	1½" Sch 40
Angle Iron	4"	3"	2¾"	2"	2"	1½"
Power Requirement	220/440V	220/440V	220/440V	220/440V	220/440V	220V 1ph
Shaft Speed "RPM"	6	8	9	10	10	6-12
Drive Motors	3	3	1	1	1	1
Motor Brake	Yes	Yes	No	No	No	No
Inverter Drive	NA	NA	NA	NA	NA	Yes
Center Roll Positioning	Hydraulic	Hydraulic	Hydraulic	Hydraulic	Manual	Manual
NC Programming	Touch pad	Touch pad	Touch pad	Touch pad	No	No
Number of Programs	8	8	8	8	NA	NA
Angle Twist Correctors	Standard**	Standard**	Optional	Optional	Optional	Optional

Note: • All capacities based on mild steel with machine in "Low bending speed"; heavy wall and high tensile materials reduce machine capacity • Consult factory for production applications and machine duty cycles.

Pipe & Tube Notchers

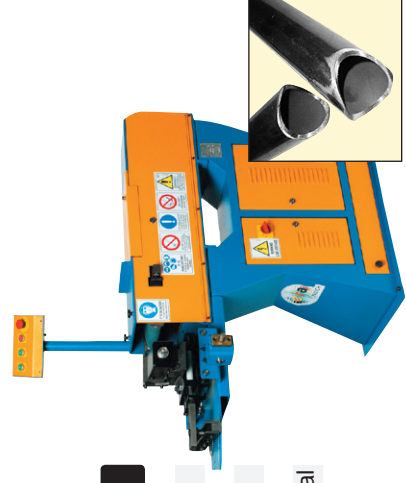

Model	EN180	EN100
Maximum Pipe Capacity	4"	2½"
Maximum Tube Capacity	4½"	3"
Angle Range	0-60°	0-60°
Power Requirement	220/440V 3ph	4" x 76¾"
Belt Size	7" x 79"	Conventional
Dust Extraction	Powered	Conventional
Grinding Wheel Capacity	7" x 5½"	4" x 5½"

CML USA Inc. Ercolina®

3100 Research Parkway Davenport, IA 52806

Phone 563-391-7700 or Fax 563-391-7710

www.ercolina-usa.com • info@ercolina-usa.com

"40 Years Excellence in Quality, Support and Service"