

NOTES:

- 101 ITEM NOT SHOWN.
- 102 SEE SHEET 4 FOR LABEL PLACEMENT.
- 103 APPLY LOCTITE #222 (REMOVEABLE THREAD LOCKER) TO THREADS. TORQUE TO 26 IN/LBS.
- 104. CONNECT ONE END OF A-24517-6 TO CUTTING HEAD EAR. ROUTE THROUGH MOTORS AND CABLE MANAGEMENT.

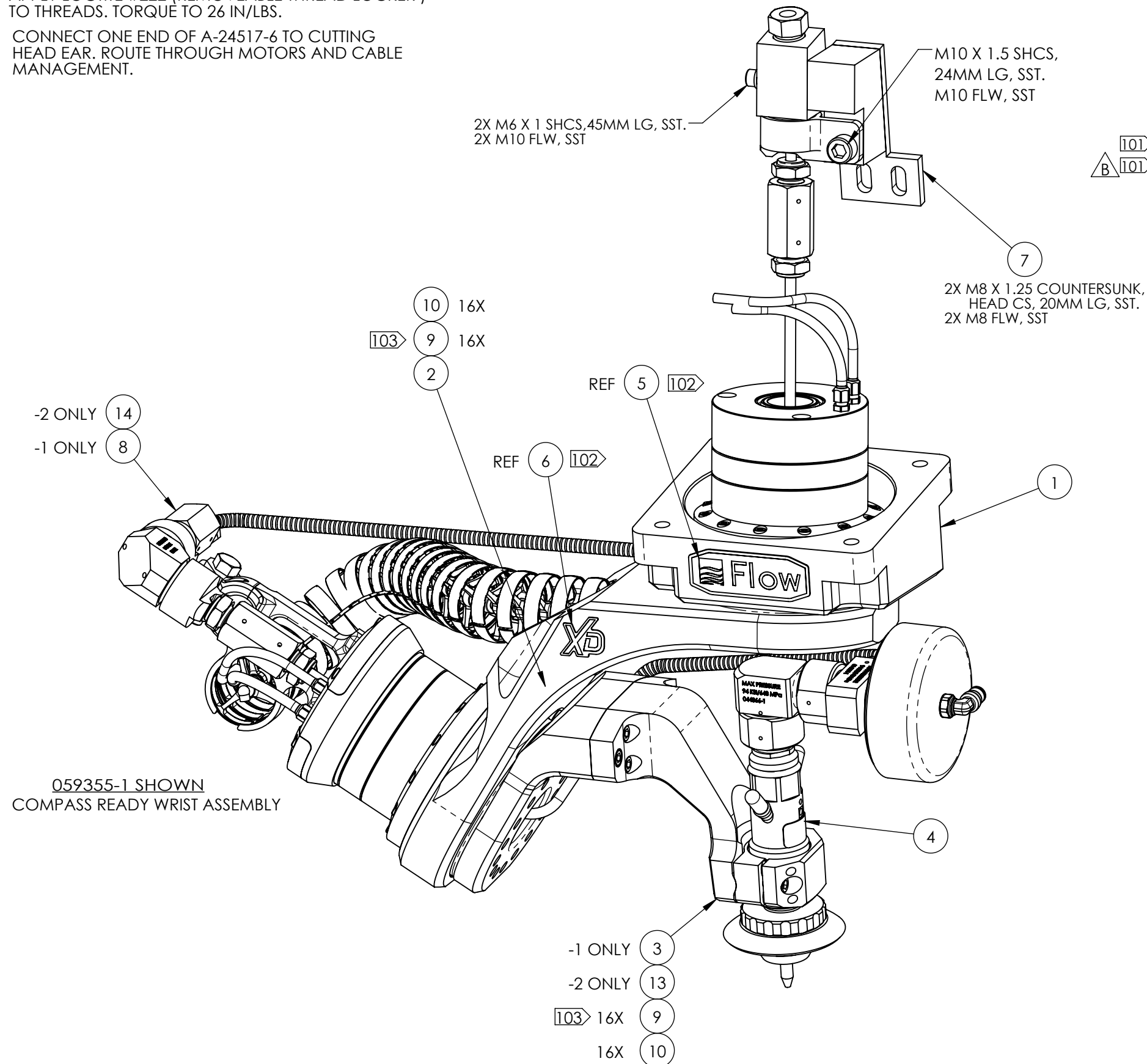

059355-1 SHOWN
COMPASS READY WRIST ASSEMBLY

ITEM	-2	-1	U/M	PART NUMBER	DESCRIPTION
1	1	1	EA	049550-2	MOTOR ASSY;TOP;XD WRIST
2	1	1	EA	049571-2	ACTUATOR ASSY;XD WRIST;87 KSI;W/BRKT
3	-	1	EA	058200-1	BRACKET ASSY;MTG;B AXIS;COMPASS
4	1	1	EA	045160-3	CUTTING HEAD ASSY;ABR JET;XD WRIST
5	1	1	EA	047232-1	LABEL;FLOW LOGO;ADH BACK VINYL
6	1	1	EA	047233-1	LABEL;ID;ADH BACK VINYL;1.10 X.96 IN
7	1	1	EA	058696-1	STAND OFF;SWVL
8	-	1	EA	060094-2	TUBING KIT;HP;WRIST;M500;87 KSI
9	32	32	EA	045870-1	SCREW;MOD;M4X0.7;XD WRIST;33MM LG
10	32	32	EA	A-23932-1	O-RING;SILICONE;70A;1 X 3 MM ID
11	6000	6000	MM	A-20193-5	TUBE;PUR;HIGH DUROMETER;BLU;2.4 MM ID
12	6.5	3	FT	A-24517-6	TUBE;PUR;SOFT A68;BLU;3/16 IN ID
13	1	-	EA	045140-2	BRACKET ASSY;MTG;B AXIS;XD
14	1	-	EA	060094-1	TUBING KIT;HP;WRIST;M500;87 KSI

ENGINEERING REFERENCE	
PART NUMBER	DESCRIPTION
059355-1	WRIST ASSY; DWJ-XD;M500;COMPASS READY
059355-2	WRIST ASSY; DWJ-XD;M500;LHS READY



COMPLETE METALWORKING SOLUTIONS
 (800) 991-4225
 www.ahbinc.com
 ISO Certified
 customerservice@ahbinc.com

THIRD ANGLE PROJECTION		THIS DRAWING IS THE PROPERTY OF FLOW INTERNATIONAL CORPORATION AND IS NOT TO BE COPIED OR REPRODUCED WITHOUT THE WRITTEN CONSENT OF FLOW INTERNATIONAL CORPORATION.		
MATERIAL		SEE BOM		
DRAWN BY K.CLAEYS	STARTED 10/24/2016	ENG D. KOWALCZYK	EST WEIGHT N/A	MODELED IN SOLIDWORKS
TITLE WRIST ASSY;DWJ-XD;M500				
REVISION B	SCALE 1:2.75	BASE PART NUMBER	059355	

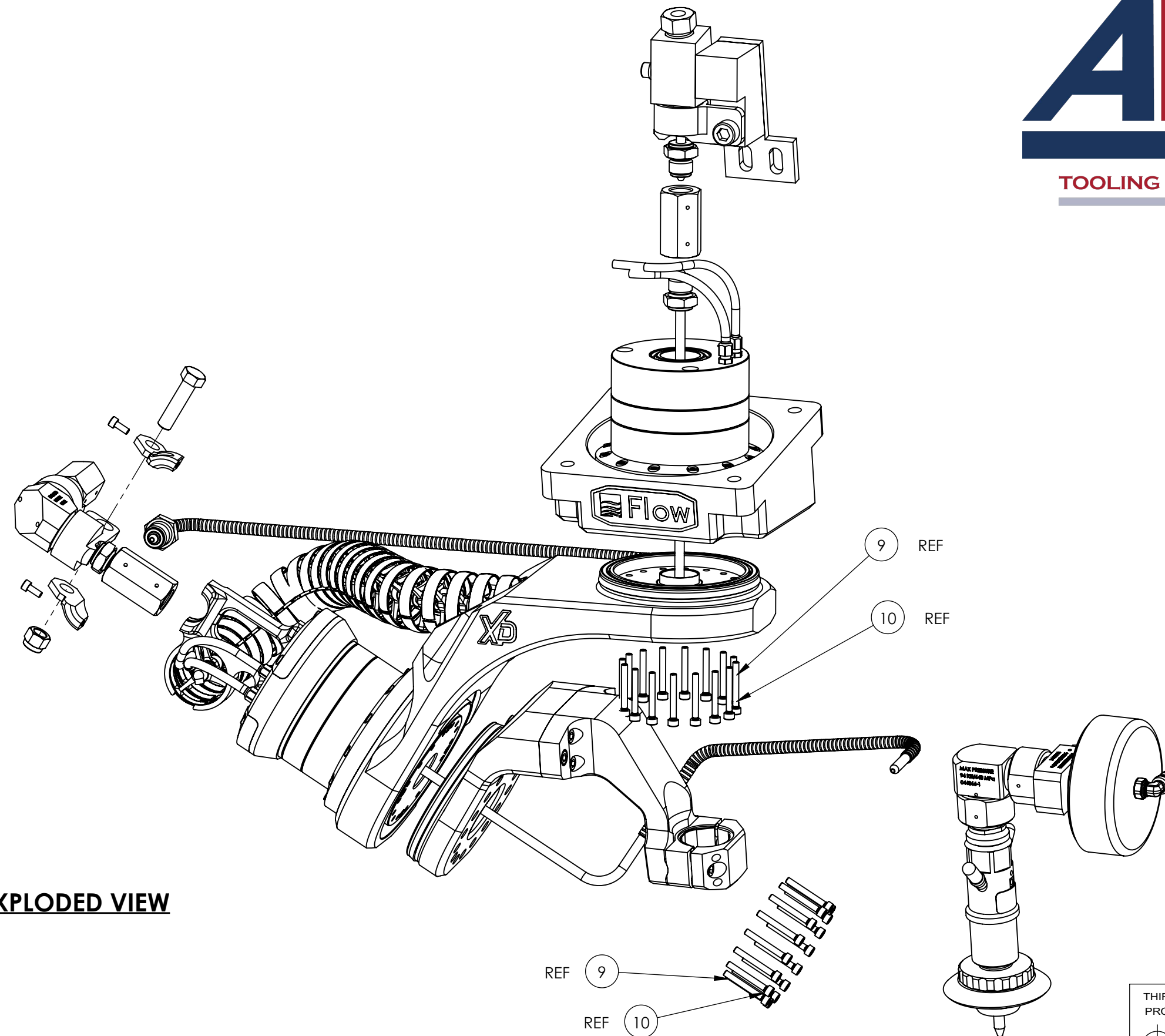

EXPLODED VIEW

THIRD ANGLE PROJECTION 			THIS DRAWING IS THE PROPERTY OF FLOW INTERNATIONAL CORPORATION AND IS NOT TO BE COPIED OR REPRODUCED WITHOUT THE WRITTEN CONSENT OF FLOW INTERNATIONAL CORPORATION.		
	MATERIAL SEE BOM				
DRAWN BY K.CLAEYS	STARTED 10/24/2016	ENG D. KOWALCZYK	EST WEIGHT N/A	MODELED IN SOLIDWORKS	
TITLE WRIST ASSY;DWJ-XD;M500					
REVISION B	SCALE 1:3	BASE PART NUMBER	059355		2 OF 3

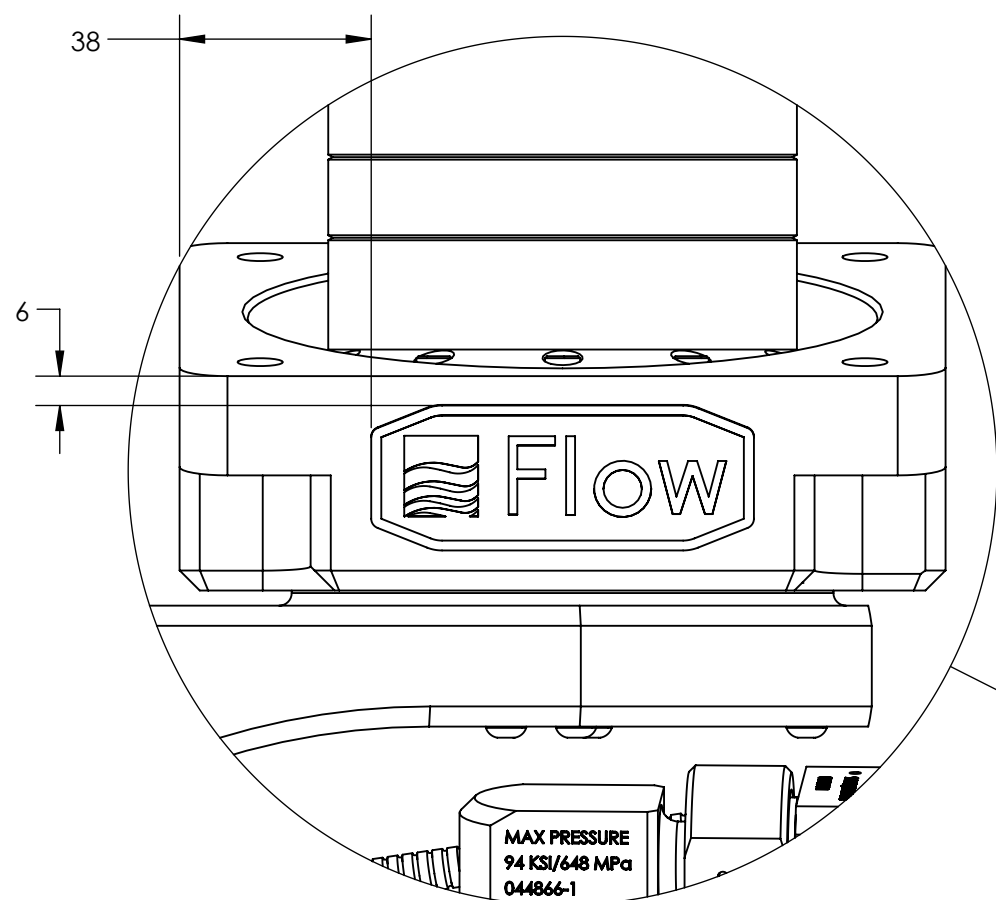

DETAIL B
SCALE 1 : 1.5

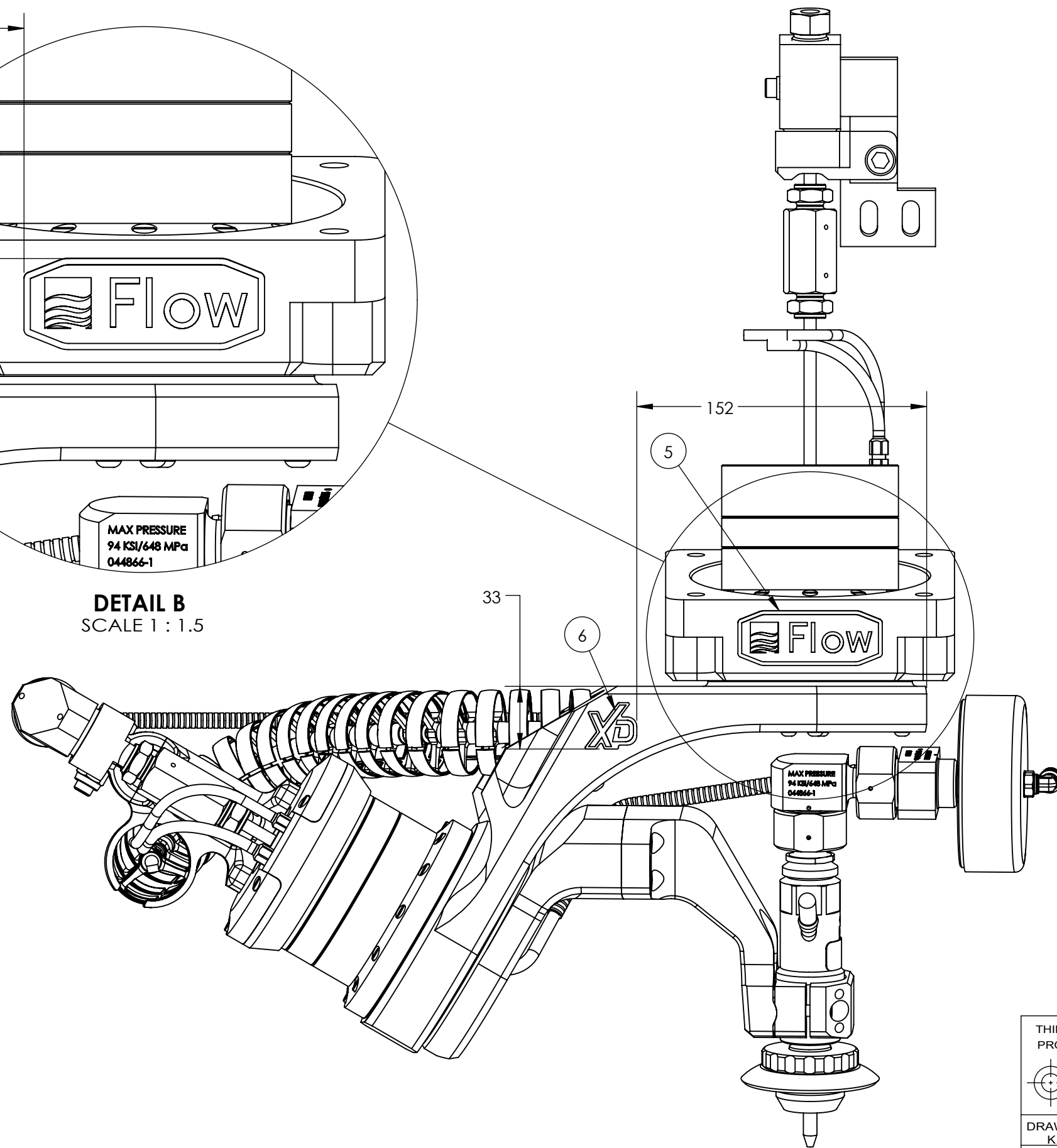

THIRD ANGLE PROJECTION 			THIS DRAWING IS THE PROPERTY OF FLOW INTERNATIONAL CORPORATION AND IS NOT TO BE COPIED OR REPRODUCED WITHOUT THE WRITTEN CONSENT OF FLOW INTERNATIONAL CORPORATION.		
	MATERIAL SEE BOM				
DRAWN BY K.CLAEYS	STARTED 10/24/2016	ENG D. KOWALCZYK	EST WEIGHT N/A	MODELED IN SOLIDWORKS	
TITLE WRIST ASSY;DWJ-XD;M500					
REVISION B	SCALE 1:2.5	BASE PART NUMBER	059355		3 OF 3