

Introduction

Use the procedure in this service bulletin when installing the Major Maintenance Kit on your HyPlex Prime pump. This service is performed at every fourth required maintenance interval for the life of the equipment. The complete major maintenance kit schedule is listed in your FLOW service manual.

Tools

You will need the following tools:

- Pressure loading tool (049512-1)
- Combination wrenches (14 mm to 32 mm)
- ½ in. drive socket set (14 mm to 32 mm)
- ½ in. torque wrench (10 to 200 ft-lb)
Note: You may need two torque wrenches.
- Feeler gauge set
- Screwdriver set
- Snap-ring pliers
- 0-1 in. micrometer or dial caliper
- 3/8 in. hex bit
- ½ in. hex bit

Repair kit

Major maintenance kit, 050624-2

CAUTION

Failure to follow these step-by-step instructions and the procedures in your FLOW service manual could result in premature failure or damage to the equipment.

Note: All components should be clean and free of debris prior to assembly. Keeping the work area clean is important while working on the equipment.

Parts identification

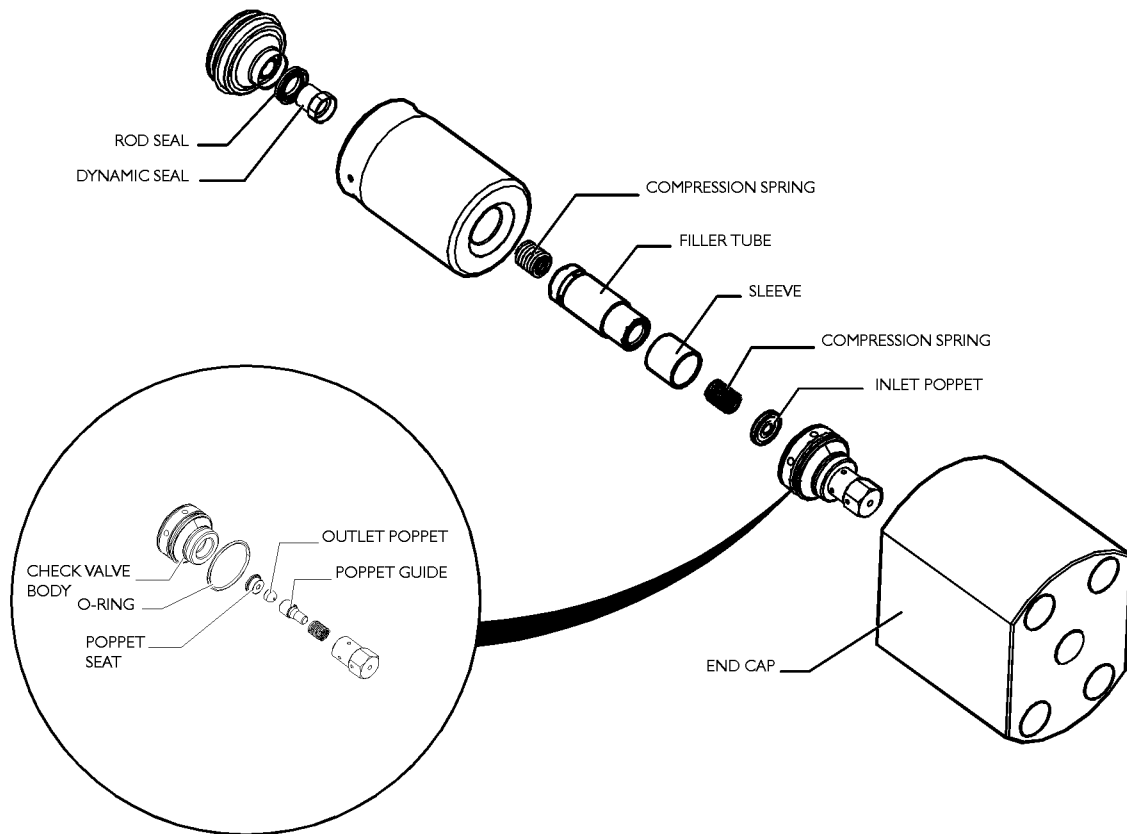

Disassembly

1. Push in the E-stop.

WARNING

Place the main electrical disconnect OFF and bleed down all high-pressure lines. Place an "Out of Service" tag on the main electrical disconnect and lock it out. Failure to do so may result in equipment damage or injury to personnel.

2. Disconnect all high-pressure and low-pressure interface connections to access the tie rods. Place the manifold and PCV assembly combination aside.

Unload the tie rods with the pressure loading tool

3. Make sure the pressure loading tool plunger is fully retracted. Install the pressure loading tool onto the tie rods by running the tool studs onto the exposed threads of the tie rods.

When tightening, alternate between opposite studs to avoid binding. Tighten the tool studs firmly in order to seat the tool piston fully into the tool body, and against the end cap as shown below.

Notes:

- The plunger of the pressure loading tool must be threaded all the way out in order to fully seat the piston within the cylinder.
- When engaged on the tie rods, there should be no exposure of the piston shoulder.

4. Back out the four tool studs 1/4 turn. This will aid in easy removal of the loading tool after unloading is complete.
5. Use the 19 mm (3/4 in.) socket and ratchet to rotate the tool plunger counter-clockwise until a value of 1500 bar gauge pressure is reached.
6. Loosen the four primary hex nuts two full turns. Use the 24 mm (15/16 in.) combination wrench if needed.
7. Use the 19 mm socket and ratchet to rotate the tool plunger counter-clockwise until the gauge pressure reads 0 bar. Rotate the tool plunger until it is fully retracted.
8. Back out all four of the tool studs to remove the tool from the tie rods.

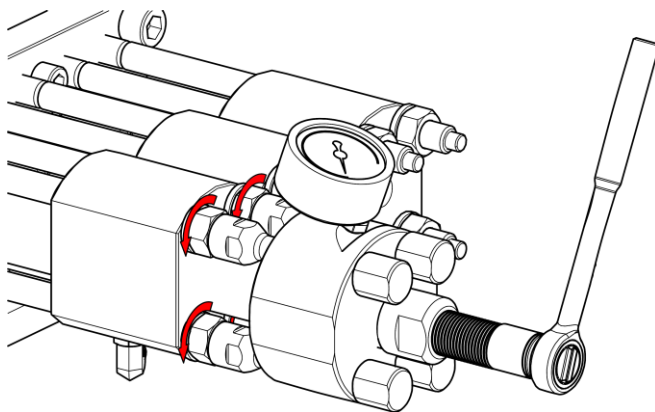
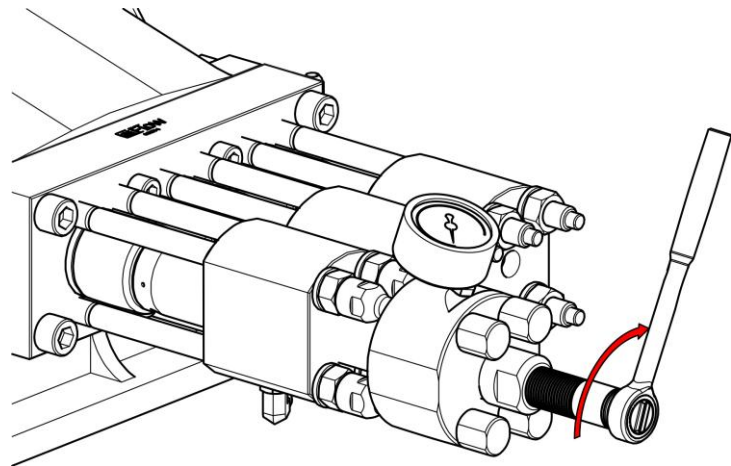

Note: Alternate between opposite studs to avoid binding. Use the 22 mm (7/8 in.) combination wrench if needed.

9. Repeat steps 3–8 for the remaining positions

For each of the three high-pressure cylinders

10. Remove the end cap, high-pressure cylinder, inlet poppet, springs, filler tube, and sleeve.
11. Separate the spring from the inlet poppet. Discard the spring, filler tube sleeve, and high-pressure cylinder.
12. If the dynamic seal carrier did not slide off with the cylinder, remove it now. If the dynamic seal carrier remains secure in the high-pressure cylinder, remove the high-pressure cylinder contents and discard the dynamic seal carrier and high-pressure cylinder.

CAUTION

**Use care when removing the dynamic seal and rod seal.
Do not scratch or nick the seal carrier bores.**

13. Remove the subplate adapter. If necessary, use pry bars or screwdrivers to remove the adapter. Remove the snap ring from the subplate adapter using snap ring pliers. Remove the spacer and seal. Remove the two o-rings from the outer diameter of the adapter. Discard the seal, o-ring, and snap ring. Keep the spacer for reuse.

14. Place the end cap vertically on a work bench with the check valve end up.
15. Remove the check valve assembly from the end cap: use two pry bars in the circumferential groove in the OD of the check valve body, prying gently on the body. Be careful not to damage the end cap.
16. Place the check valve body in a soft-jawed vise. Loosen the outlet cage.
17. Remove the outlet poppet and guide, outlet poppet spring, and outlet poppet seat from the outlet cage. Retain the cage. Discard the outlet poppet and guide, outlet poppet spring, and outlet poppet seat.

Lap inlet face of check valve body

18. Use the glass lapping plate from the tool kit and lapping paper from the repair kit.
19. Lightly wet the paper with water. Place the check valve body with the inlet face against the lapping paper. With a light downward pressure, lap the body in a figure 8 pattern.

CAUTION

Be very careful not to rock the check valve body while lapping the surface – flatness is very critical.

After 10-12 laps, rotate the check valve body 45° and continue lapping until the surface has a smooth matte finish free of any deep scratches or signs of deformation from the inlet poppet. Re-wet the paper as needed.

20. Thoroughly clean the check valve body openings to remove particles from the lapping procedure.

Reassembly

Assemble the check valve

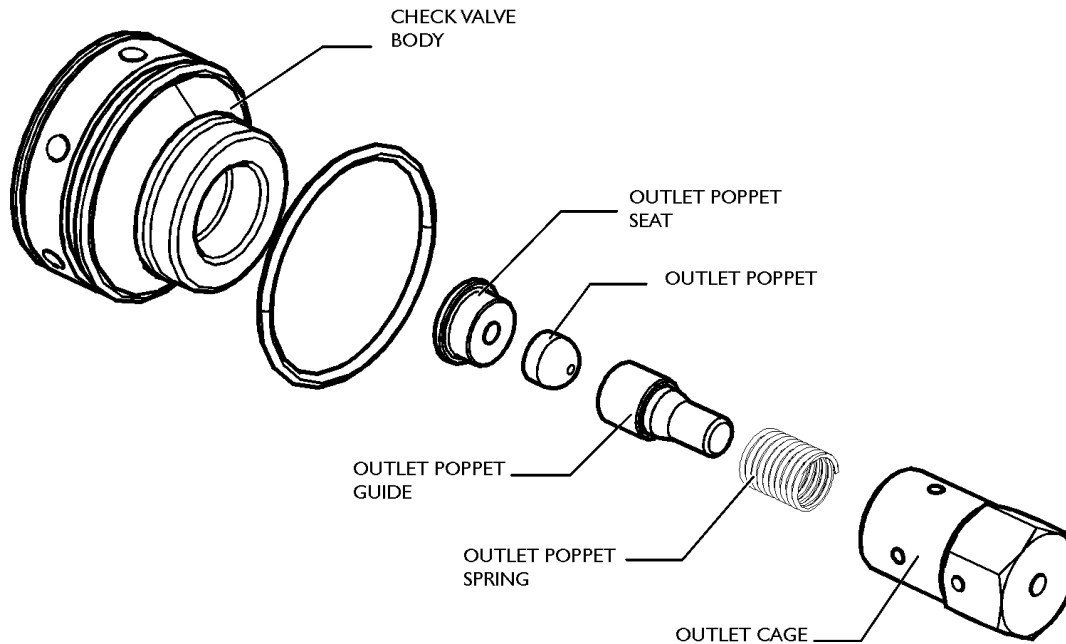

1. Insert the outlet poppet into the outlet poppet guide.

Note: Install poppet into the outlet poppet guide as shown, with the radiused back of the outlet poppet going in first. The counterbore in the outlet poppet should be visible after installation.

2. Place the outlet poppet spring around the guide. The spring should be loose on the guide.
3. Place the assembly into the outlet cage along with the outlet poppet seat.
4. Hold the outlet cage assembly upright (threaded end of the outlet cage facing up) so that the installed components will not fall out. Lightly apply Blue Lubricant to the threads of the outlet cage.
5. Carefully thread the new check valve body onto the outlet cage assembly.
6. Secure the rebuild clamp in a vise.
7. Secure the check valve body in the rebuild clamp with the inlet face downward. Torque the outlet cage to 30 ft-lb (41 N-m).

Repeat Steps 1-7 for the remaining check valves.

Assemble the end cap

1. Lightly lubricate the check valve o-ring and end cap o-ring with o-ring lube and install them into the grooves on the check valve body and end cap.
2. With the outlet cage facing the end cap, insert the check valve body into the end cap.

Repeat for the remaining end caps.

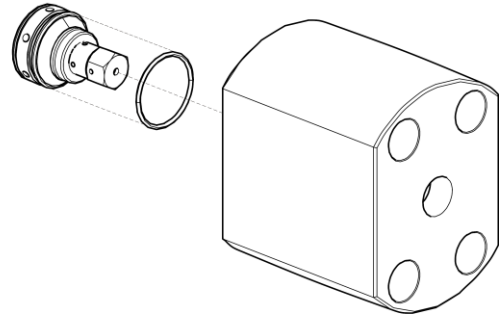

Check plunger torque

1. Carefully slide the plunger nut tool (provided in the tool kit) over the plunger. With a torque wrench and plunger nut tool, check plunger nut torque. Torque to 20 ft-lb (27 N-m).
2. Rotate the sheave to fully extend the next plunger to be checked.

Repeat for the remaining plungers. When finished, wipe off any dirt or grease on all plungers.

Assemble the subplate adapter

1. Make sure the tie rods are firmly seated in the subplate.
Note: Hand tight is sufficient.
2. With the split face down, install the rod seal in the counterbore of the subplate adapter.
3. Place the spacer in the counterbore with the chamfered side down (toward the newly installed seal). Secure with the new snap ring.
4. Lubricate and install the two o-rings onto the adapter, and slide the adapter over the plunger until it engages the counterbore of the subplate.

Repeat steps 1-3 for the remaining subplate adapters

Assemble and install the dynamic seal carrier

1. Inspect the dynamic seal carrier for cleanliness and erosion damage. Erosion damage at the innermost corner will cause seal life to be reduced. Make sure the guide bearing is in good condition. (The presence of cracked or loose pieces is reason for replacement.) Replace the dynamic seal carrier if necessary. Clean as necessary.
2. Install the rod seal as shown, with the v-shape facing up, into the dynamic seal carrier.
3. Install the dynamic seal into the inner diameter of the rod seal, making sure the dynamic seal is fully seated against the dynamic seal carrier.

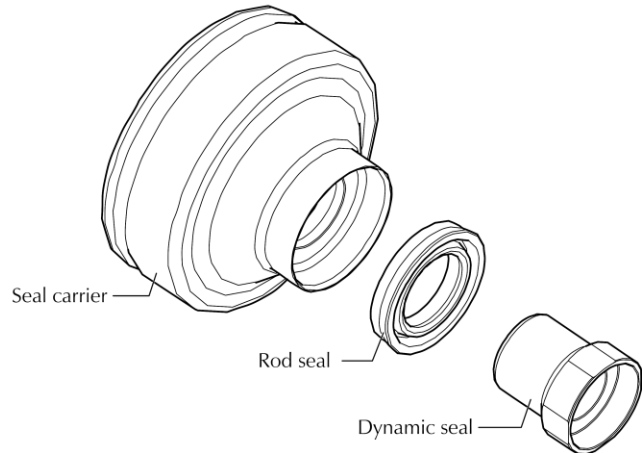

Note: Make sure the plungers are clean and free of any damage or scratches before installing the dynamic seal carriers. The subplate adapter/seal carrier interface must be clean and free of debris.

4. Slide the dynamic seal carrier onto the plungers until seated against the register of the subplate adapter.

Install the high-pressure cylinder

1. Lubricate the o-ring with o-ring lube and place it in the groove of the new high-pressure cylinder.
2. Slide the new high-pressure cylinder over the plunger assembly and seat it against the seal carrier. Position the cylinders with weep holes facing downward.

Note: Slight force may be needed to seat the high-pressure cylinder to the seal carrier.

Repeat for the remaining high-pressure cylinders.

Assemble the inlet poppet

1. Place the inlet poppet spring over the shouldered side of the inlet poppet.
2. Apply pressure to the spring and rotate counterclockwise until it snaps into place. Be sure the spring is firmly attached.

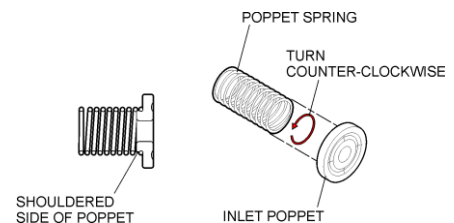

Repeat for the remaining inlet poppets.

Assemble the filler tube

The filler tube sleeve helps align the poppet with the check valve body and prevents pinching of the poppet between the check valve and the filler tube during assembly.

1. Place the dynamic seal compression spring into the tapered end of the filler tube.
2. Insert the filler tube, spring end first, into the high-pressure cylinder, making sure to engage the spring into the dynamic seal.

Repeat for remaining filler tubes.

3. Insert inlet poppet assembly into the filler tube, spring end first.
4. Partially install the filler tube sleeve so that it surrounds the inlet poppet and spring.

Repeat for the remaining filler tube assemblies.

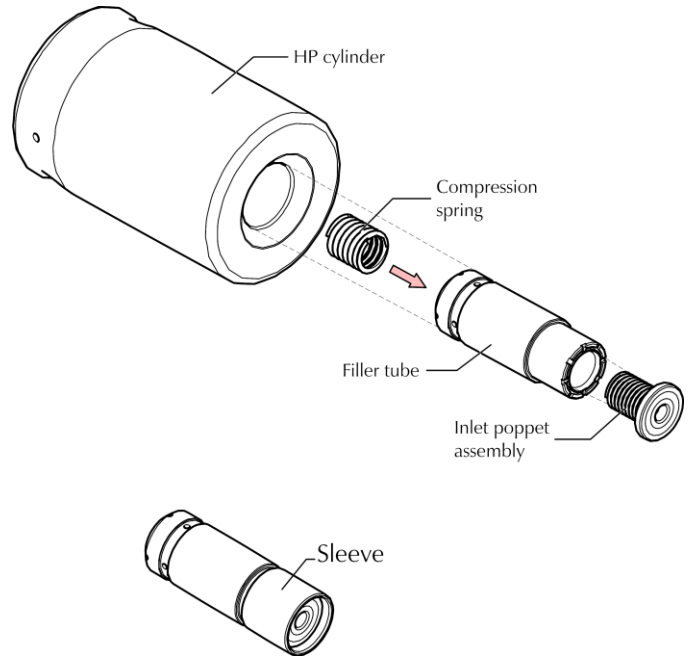

Install the end cap

CAUTION

It is important that you do not let the end cap spring back while installing. If it does, the inlet poppet can be pinched, causing damage.

Make sure all the split bearings (bushings) are completely seated in the end cap. Incorrect installation will cause inappropriate loading of the high-pressure position.

1. Make sure all eight of the end cap split bearings (bushings) are installed in the end cap.
2. Align the end cap so it will slide over the tie rods, then carefully slide the end cap back until the check valve makes contact with the inlet poppet.
3. Continue sliding the end cap back until the high-pressure cylinder engages the o-ring in the end cap and the check valve seats against the high-pressure cylinder.
4. Temporarily install one of the hex nuts, hand tight, to prevent the end cap from springing back.

Follow Steps 1-4 to install the other two end caps, then continue with Step 5.

5. Apply anti-seize compound to both sides of the washers and to the tie rod threads.
6. Install washers and hex nuts hand tight.
7. Remove the temporarily installed hex nuts. Apply anti-seize to both sides of the washers and threads, then reinstall the nuts.

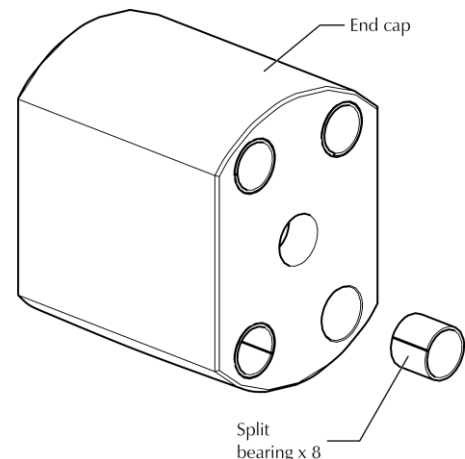

Load the tie rods & manifold

1. Install the pressure loading tool onto the tie rods by running down the tool studs onto the exposed threads of the tie rods.

When tightening, alternate between opposite studs to avoid binding. Tighten the tool studs firmly in order to seat the tool piston fully into the tool body, and against the end cap as shown below.

Notes:

- The plunger of the pressure loading tool must be threaded all the way out in order to fully seat the piston within the cylinder.
- When engaged on the tie rods, there should be no exposure of the piston shoulder.

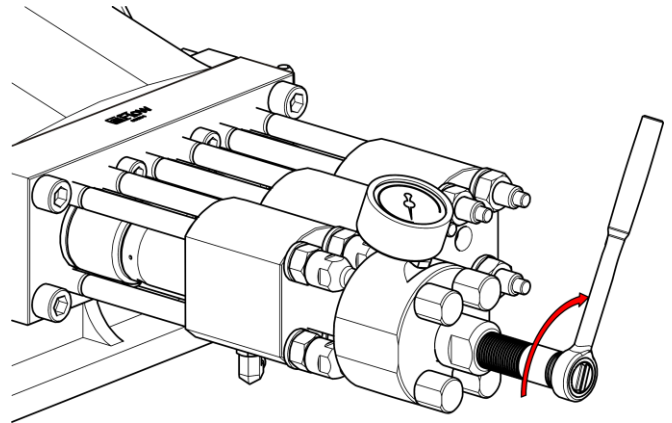

2. Use a socket wrench to turn the loading tool plunger clockwise until the gauge reads **1500 bar**.
3. Run the primary nuts of the pump down by hand until firmly seated against the end caps. These nuts must be fully bottomed-out against the washers/end caps.

Note: Do not use wrenches when threading the primary nuts down.

4. Use the socket wrench to remove pressure from the tool. The gauge will read **0 bar** when pressure has been removed.
5. Back out all four of the tool studs to remove the tool from the tie rods.

Note: When loosening, alternate between opposite studs to avoid binding.

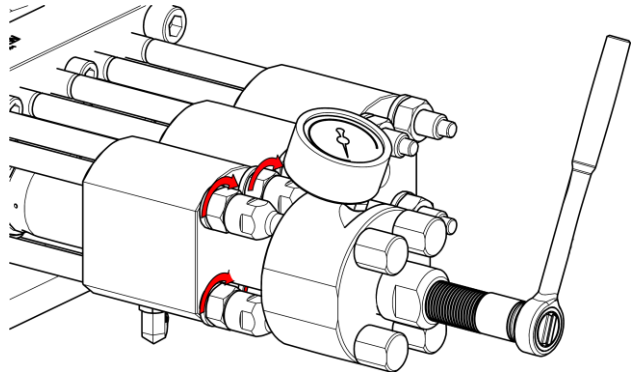

6. Repeat steps 1 through 5 for the remaining positions.
7. Apply Blue Lubricant to each of the threads on the 3/8 in. high-pressure glands.
8. On each end of the tube, slide a gland on and thread a collar (A-2839) on the threaded ends of the tube.
9. Repeat Steps 33-35 for the remaining two high-pressure tubes.
10. Insert one end of the tube into the high-pressure port on the manifold and loosely thread the glands. Repeat for the other two high-pressure tubes.
11. Loosely thread the other end of each of the three tubes into the end cap ports.
12. Once in place, tighten all six gland nuts.
13. Reconnect all high-pressure and low-pressure interface connect

Complete the kit installation

1. Remove the drain plug or oil temperature sensor from the crankcase drain and completely drain the oil.
2. Re-install the drain plug or oil temperature sensor and fill the crankcase with recommended oil (refer to Chapter 1 of your service manual).
3. **For HyPlex Prime Plus only:**
Click on **Advanced | FlowSense diagnostic** in the menu bar on the Run Machine screen. You must enter pump hours and kit installation information or the pump will not run.
4. Follow the start-up procedure in your service manual before returning the HyPlex Prime pump to service.