

***Installing the HyPlex® Prime
Pressure Control Valve (PCV)
Maintenance Kit***

Introduction

Use the procedure in this service bulletin when installing the HyPlex Prime pressure control valve (PCV) maintenance kit. The complete service schedule for the pressure control valve is listed in your service manual.

The sequence of HyPlex Prime maintenance dictates that this kit should always be done at the same time as a Major Maintenance kit installation. The poppet, seat and static seal described in this procedure are included in the Major Maintenance kit.

Tools

You will need the following tools:

- Combination wrenches (11 mm to 32 mm)
- 1/2-in. torque wrench (10-300 ft-lb)
Note: you may need two torque wrenches
- Screwdriver set
- Allen wrench set
- Needle nose pliers

Maintenance Kit

You will need a PCV maintenance kit, 050625-1.

Identifying PCV parts

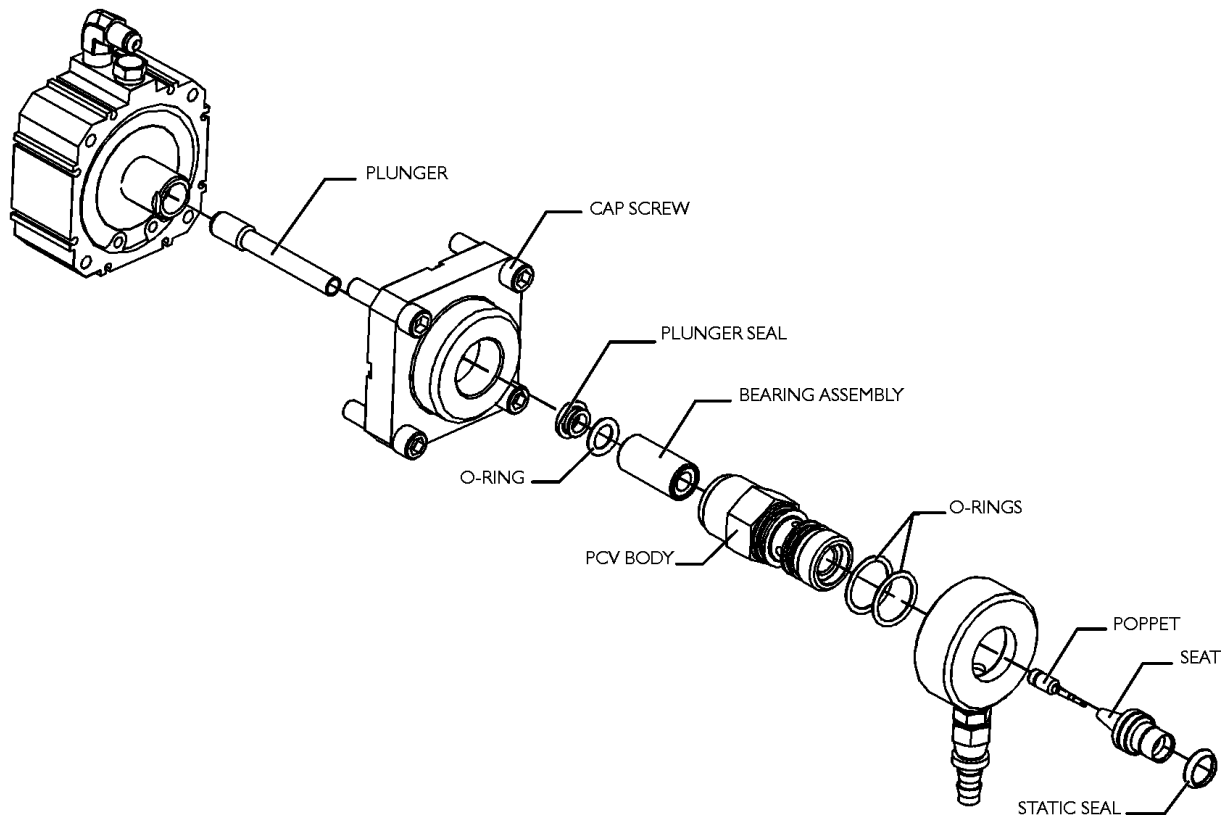

Disassembly

The poppet, bearing assembly, plunger, plunger seal, and o-rings are replaced in this procedure.

1. Shut down the system.

WARNING

Place the main electrical disconnect OFF and bleed down all high-pressure lines.

Place an "Out of Service" tag on the main electrical disconnect and lock it out.

Failure to do so may result in equipment damage or injury to personnel.

2. Reduce air pressure to 0 psi and remove the air and drain lines from the PCV.
3. Remove the PCV from the manifold.
4. Remove the poppet, seat, and seal ring from the PCV body.
Note: Needle nose pliers may be needed to remove the poppet from the assembly.
5. Remove the adapter from the valve body and discard the o-rings.
6. Place the air cylinder in a soft jaw vise. Use a 1-1/4 in. combination wrench to remove the PCV body from the air cylinder.
7. Use an Allen wrench to remove the four cap screws from the air cylinder. Separate the square mounting block to access to the plunger. Discard the plunger.

8. Push the bearing from the bore of the PCV body using the bearing removal tool (011172-1). Remove the plunger seal and o-ring. Discard the plunger seal, o-ring and bearing assembly.

Re-assembly

1. Slide the new plunger through the bore of the cylinder mount block (cap).
12. Reinstall cap onto housing and tighten the four cap screws.
13. Inspect the other non-wear components for any signs of deterioration; repair or replace as necessary.
14. Use the bearing removal/installation tool (011172-1) to push the new bearing assembly into the bore of the PCV body.
15. Lubricate the plunger seal with the provided food-grade grease. Install the o-ring onto the plunger seal, and install into the valve body.
16. With the air cylinder in a soft jaw vise, slide the body over the plunger and thread into the mount (cap) until the PCV body is firmly seated. No extreme torque is needed.
17. Clean any debris that remains in the high-pressure port of the manifold.
18. Lubricate the two new o-rings with food-grade grease. Place new o-rings on the valve body.
19. Install the adapter on the valve body.
20. Make sure the static seal ring is installed on the seat and install the poppet into the seat. This will keep these parts together so they won't be separated when installing the valve onto the manifold.

Note: Do not press poppet into the seat.

21. Place poppet and seat assembly into the end of the valve body, then thread this assembly into the high-pressure manifold. Tighten to 180 ft-lb.
22. Reconnect the air supply and drain lines.

Follow the start-up procedure in your manual before returning the equipment to service.