

FLOW STYLE INTENSIFIER TROUBLESHOOTING

SHORT BLOCK SHOWN BELOW

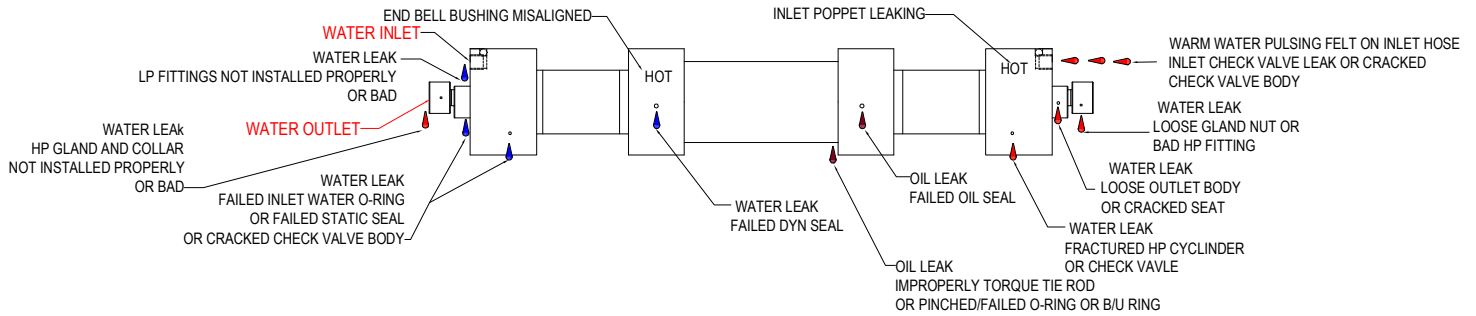

LONG BLOCK SIDE VIEW

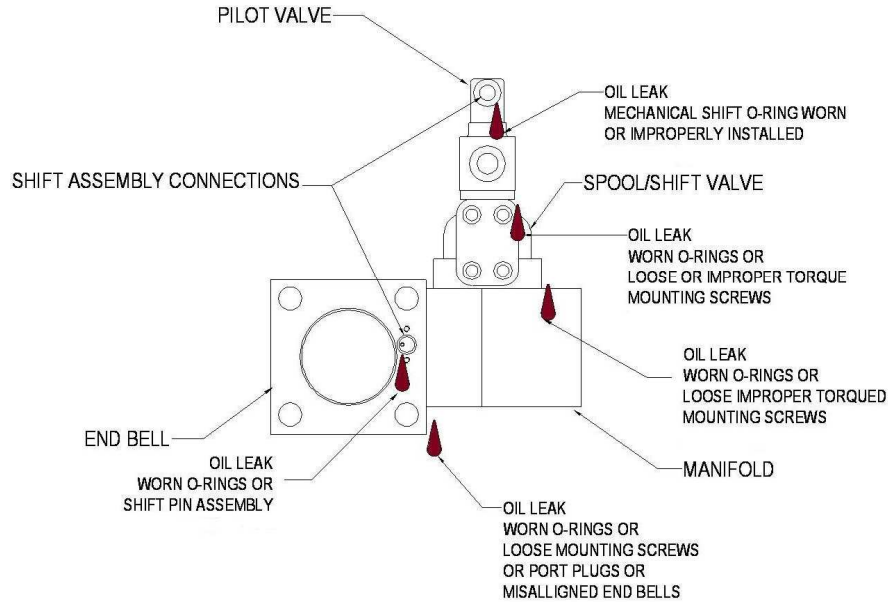

NOTE: Loose fittings can be the cause of any leaking connections. Long and short block intensifiers are broke in to minimize the probability of this happening

(800) 991-4225

www.ahbinc.com • customerservice@ahbinc.com

ISO Certified