

STREAMLINE SL-V 150 *PLUS* **WATERJET INTENSIFIER**

OPERATION AND MAINTENANCE MANUAL



NOTICE

This document contains subject matter in which KMT Waterjet Systems has proprietary rights. Recipients of this document shall not duplicate, use or disclose information contained herein, in whole or in part, for other than the purpose for which this manual was provided.

KMT Waterjet believes the information described in this manual to be accurate and reliable. Much care has been taken in its preparation; however, the Company cannot accept any responsibility, financial or otherwise, for any consequences arising out of the use of this material. The information contained herein is subject to change, and revisions may be issued advising of such changes and/or additions.

KMT WATERJET SYSTEMS 2010



KMT Waterjet Systems
635 West 12th Street
POB 231
Baxter Springs, KS 66713-0231

Phone: (800) 826-9274
Fax: (620) 856-5050

TABLE OF CONTENTS

Title Page
Notice
Table of Contents
Appendix

<i>Section</i>	<i>Page</i>
1 Introduction	1-1
1.1 Overview	1-1
1.2 Performance Features and Options	1-1
1.3 Product Nameplate	1-2
1.4 Operational Overview	1-3
Low Pressure Water System	1-3
Recirculation System	1-3
Hydraulic System	1-4
High Pressure Water System	1-4
Operating System	1-4
1.5 Safety	1-5
Lockout/Tagout Procedure	1-5
Warning Labels	1-6
Emergency Medical Treatment	1-8
1.6 Worldwide Product Support	1-9
1.7 Spare Parts	1-9
1.8 Manual Organization	1-9
1.9 Equipment and Service Manual Questionnaire	1-10
Terms and Conditions of Sale	
Terms and Conditions, Part Sales	
Terms LD-146, Domestic Service Supervisor	
Terms LD-147, International Service Supervisor	
2 Installation	2-1
2.1 Overview	2-1
2.2 Installation Summary	2-1
2.3 Site Requirements	2-2
Transporting	2-3
2.4 Power Requirements	2-3
2.5 Service Connections	2-4
Cooling Water	2-5
Cutting Water	2-6
Drain	2-6

	Plant Air	2-7
2.6	Flow Requirements	2-8
2.7	High Pressure Piping.....	2-8
	Measurements and Dimensions	2-10
	Hand Coning	2-11
	Power Coning.....	2-12
	Hand Threading	2-13
	Power Threading	2-13
2.8	High Pressure Connections	2-14
	Standard Connections	2-14
	Anti-Vibration Connections.....	2-15
2.9	Commissioning	2-16
2.10	Decommissioning	2-20
3	Maintenance	3-1
3.1	Overview.....	3-1
3.2	Maintenance.....	3-1
	Daily Inspection	3-1
	Periodic Maintenance.....	3-2
	High Pressure System Maintenance.....	3-2
3.3	Maintenance Precautions	3-3
3.4	Tool Kit.....	3-4
4	Operation	4-1
4.1	Overview.....	4-1
	Startup Sequence.....	4-1
4.2	Partial Power Operation	4-2
4.3	Display Controls	4-3
4.4	Main Menu.....	4-4
4.5	Run Screen	4-4
4.6	Valve Position Screen	4-6
4.7	Setup Screen.....	4-7
4.8	Configuration Screen	4-8
4.9	Stroke Rate Screen	4-9
4.10	Capacity Screen	4-11
4.11	Hours Screen.....	4-12
4.12	Run Screen Alarms	4-13
4.13	Alarm Banners	4-15
4.14	General Alarm Screen.....	4-19
	Installing a New Battery	4-20
4.15	Stroke Rate Alarm Screen.....	4-21
4.16	Alarm History Screen	4-22
	Changing the Date and Time	4-22
4.17	Maintenance Screen	4-23
4.18	Language Screen.....	4-24
4.19	Contact Information Screen	4-24

5	Low Pressure Water System	5-1
5.1	Overview.....	5-1
5.2	Cutting Water Supply	5-1
5.3	Operation.....	5-2
5.4	Service and Maintenance Procedures	5-6
	Filter Assembly.....	5-6
	Strainer Maintenance	5-7
	Relief Valve Adjustment.....	5-7
6	Recirculation System	6-1
6.1	Overview.....	6-1
6.2	Operation.....	6-2
6.3	Service and Maintenance Procedures	6-3
	Hydraulic Oil Maintenance.....	6-3
	Electric Motor Bump	6-6
	Oil Filter Maintenance	6-7
	Operating Temperature Adjustment	6-8
7	Hydraulic System	7-1
7.1	Overview.....	7-1
7.2	Operation.....	7-1
	Redundant Models	7-3
7.3	Service and Maintenance Procedures	7-4
	Proportional Valve Maintenance	7-4
	Motor Maintenance.....	7-6
8	Electrical System	8-1
8.1	Overview.....	8-1
8.2	Operation.....	8-1
	Sensors and Solenoids.....	8-4
8.3	Service and Maintenance Procedures	8-8
	Proximity Switch Maintenance.....	8-8
	Optical Relay Maintenance.....	8-9
9	High Pressure Water System	9-1
9.1	Overview.....	9-1
9.2	Operation.....	9-2
9.3	Operating Configuration	9-3
	Redundant Models	9-5
9.4	System Components.....	9-8
9.5	Service and Maintenance Overview	9-9
	Torque Specifications	9-10
	Specialized Maintenance Tools	9-12
9.6	High and Low Pressure Water Connections	9-13
9.7	High Pressure Cylinder Assembly	9-15
	High Pressure Cylinder Assembly Removal.....	9-15

	High Pressure Cylinder Assembly Installation	9-16
	High Pressure Cylinder Maintenance	9-17
9.8	Hard Seal End Caps	9-18
	Hard Seal End Cap Removal	9-18
	Hard Seal End Cap Installation.....	9-19
9.9	Sealing Head	9-20
	High Pressure Discharge Check Valve.....	9-20
	Low Pressure Inlet Check Valve.....	9-22
	Sealing Head Maintenance	9-23
9.10	High Pressure Seal Assembly	9-23
9.11	Hydraulic Cartridge Seal and Plunger Removal.....	9-26
	Plunger Maintenance	9-28
	Plunger Installation	9-29
	Hydraulic Cartridge Seal.....	9-29
9.12	Hydraulic Piston.....	9-31
	Hydraulic Piston Removal	9-31
	Bearing Rings and Seal Assembly	9-33
	Plunger Button Sockets, Seals and Retainer Pins	9-34
	Internal Check Valves.....	9-34
	Hydraulic Piston Installation.....	9-35
9.13	Hydraulic Cylinder Maintenance	9-36
9.14	High Pressure Attenuator	9-36
9.15	High Pressure Dump Valve	9-37
	Pneumatic Control Valve.....	9-38
	Pneumatic Actuator.....	9-42
9.16	Weep Holes.....	9-42
10	Troubleshooting	10-1
10.1	Overview.....	10-1
10.2	Troubleshooting Guide	10-2
10.3	Softstarter	10-12
11	Specifications	11-1
11.1	Overview.....	11-1
11.2	Installation Specifications.....	11-1
	Environment.....	11-1
	Sound Level	11-1
	Equipment Dimensions and Weights.....	11-2
	Service Connections.....	11-2
	Plant Air	11-2
11.3	Water Specifications	11-3
	Cutting Water Supply	11-3
	Cooling Water Supply.....	11-4
	Water Quality Standards	11-4
11.4	Electrical Specifications.....	11-7
	Electrical System	11-7

	Ampacity and Power Voltage Requirements	11-7
11.5	Hydraulic and High Pressure Water System Specifications	11-7
	Hydraulic System.....	11-7
	High Pressure Water System	11-7
	Orifice Capacity	11-8
11.6	Torque Specifications	11-10
12	Parts List.....	12-1
12.1	Overview.....	12-1
12.2	Part Nomenclature	12-2
12.3	Index	12-3

APPENDIX

Exhibit

System Schematics
Electrical Schematics
Material Safety Data Sheets



SECTION 1

INTRODUCTION

1.1 Overview

The Streamline SL-V 150 and 200 *Plus* unite the proven performance features of the SL-V series with the pressure, horsepower and flow rate to drive multiple heads for virtually any waterjet cutting application. Robust performance and standard features are the result of aggressive development and decades of experience.

The standard models utilize two intensifier assemblies for full power operation. The redundant unit is equipped with three intensifiers to allow operation to continue if a problem is detected on one assembly. The operating configuration can be quickly changed until the next convenient shutdown, when service can be performed.

Table 1-1
Streamline SL-V 150 and 200 *Plus*

Model	Motor Horsepower Rating		Maximum Operating Pressure	Maximum Flow Rate (<i>at full pressure</i>)	Maximum Single Orifice Diameter (<i>at full pressure</i>)
	HP	Kw			
SL-V 150	150	112	60,000 psi (4,137 bar)	2.7 gpm (10.2 L/min)	0.023 inch (0.584 mm)
SL-V 200	200	150	60,000 psi (4,137 bar)	3.6 gpm (13.6 L/min)	0.026 inch (0.660 mm)

1.2 Performance Features and Options

The SL-V 150 and 200 combine all the unique capabilities and advantages of waterjet cutting with the reliability, ease of operation and service support that have made KMT Waterjet Systems a leader in waterjet technology.

- A 150 or 200 horsepower motor delivers continuous operation at 60,000 psi (4,137 bar).
- The soft start feature minimizes system mechanical and electrical stress, greatly reducing shock to the system.
- An internal balancing system ensures consistent operating pressure and even load distribution.
- Water and hydraulic pressure, throughout the system, can be observed from a single gauge display.
- The standard 3-liter attenuator ensures steady and consistent water supply.
- Partial power allows operation with a single intensifier.

- Comprehensive fault detection and troubleshooting logic monitor crucial pressure, temperature and fluid levels.
- Warning and shutdown sensors guard against potential equipment damage.

1.3 Product Nameplate

The product nameplate contains the pump model, serial, identification and part numbers for each individual machine.

Figure 1-1: Nameplate

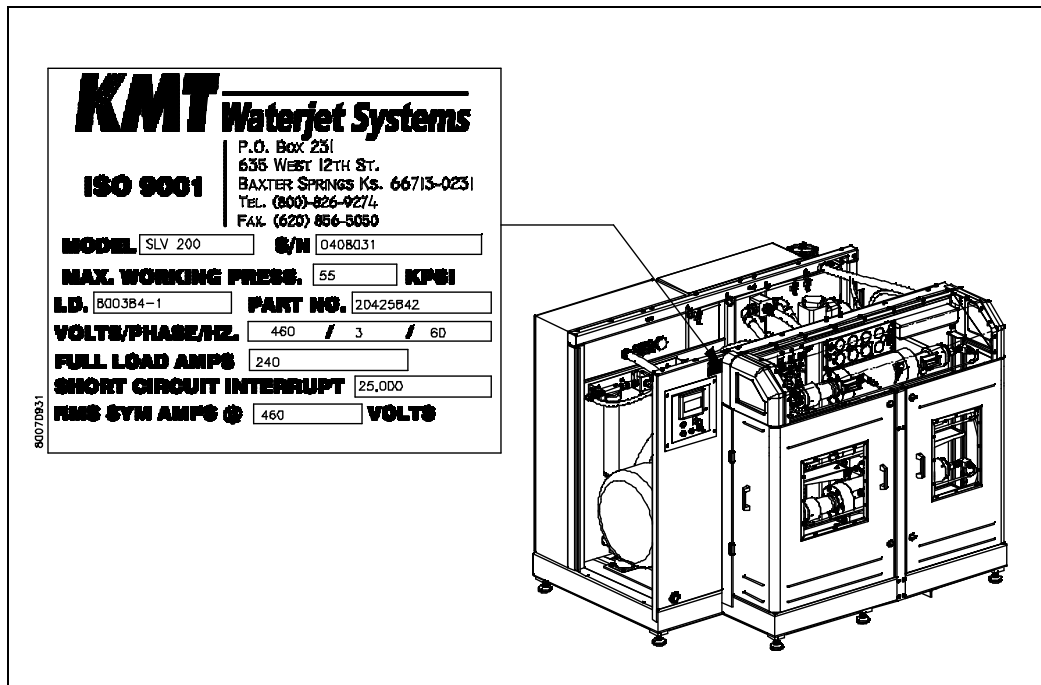

1.4 Operational Overview

The following provides a brief overview of the function and primary components associated with the individual systems. A detailed discussion of each system is provided in Sections 4 through 9.

Low Pressure Water System

The low pressure water system supplies the cutting water flow to the intensifiers. Major system components include the water filter assembly, low pressure water manifold, and the booster pump driven by an auxiliary motor.

Figure 1-2: System Components

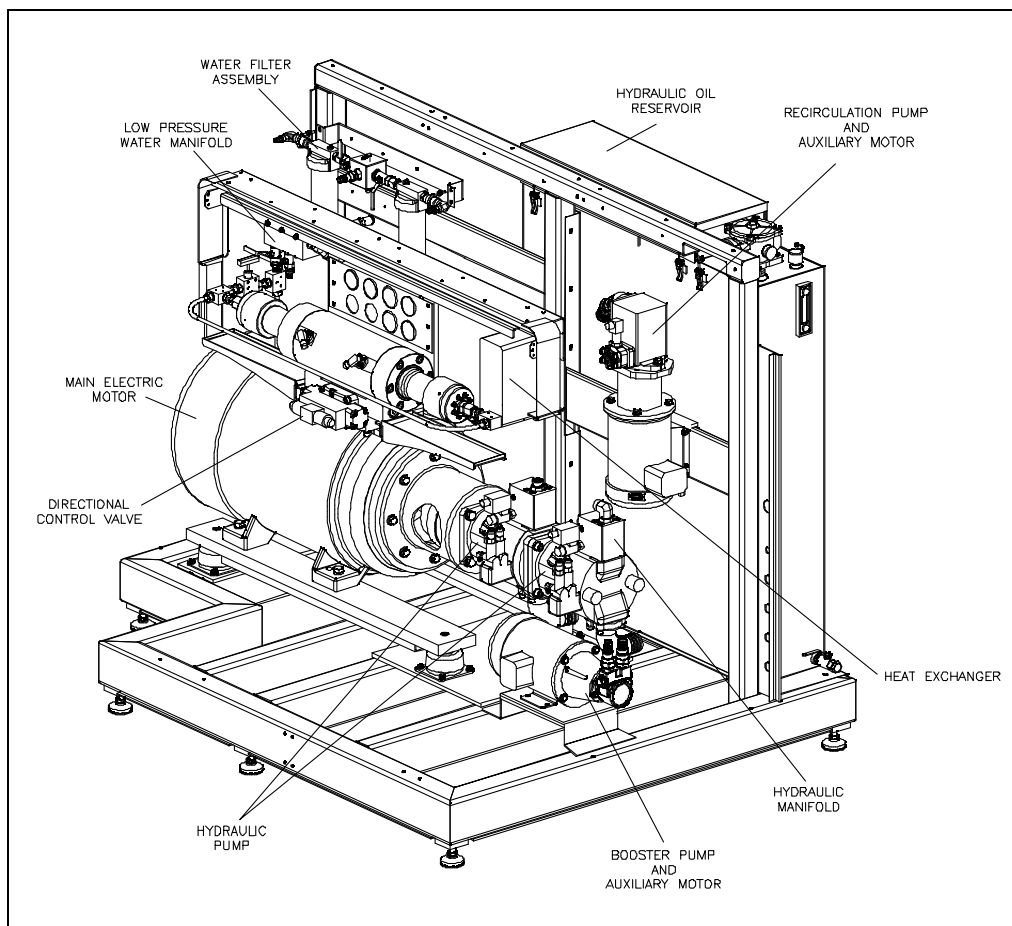

Recirculation System

The recirculation system is a cooling and filtration system that provides properly conditioned oil to the main hydraulic system. Major system components include the heat exchanger, oil filter assembly, hydraulic oil reservoir, and the recirculation pump driven by a second auxiliary motor.

Hydraulic System

The hydraulic system supplies the intensifier with the hydraulic oil required to produce high pressure water. Major system components include the main electric motor, two hydraulic pumps and the 4-way directional control valves.

High Pressure Water System

The high pressure water system is the heart of the waterjet system. Water is pressurized and continuously delivered to the cutting head. As water passes through a tiny hole in the orifice, water pressure is converted to water velocity capable of cutting most any material.

Major system components include two intensifier assemblies, attenuator and the safety dump valve.

Figure 1-3: High Pressure System Components

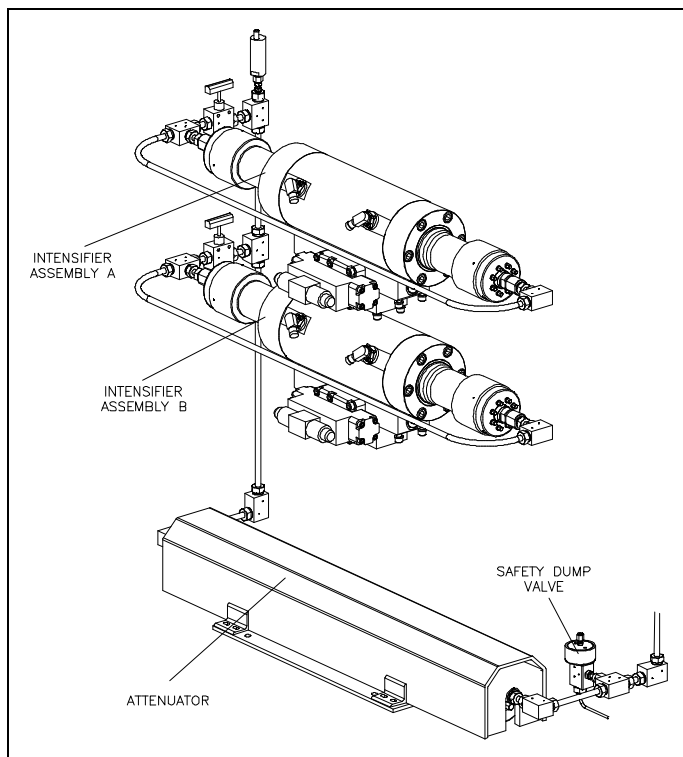

Operating System

A programmable logic controller (PLC) provides basic intensifier shift control and monitors out of limit conditions. Operator interface is through the control panel display where operating parameters are set and monitored.

Figure 1-4: Control Panel Main Menu

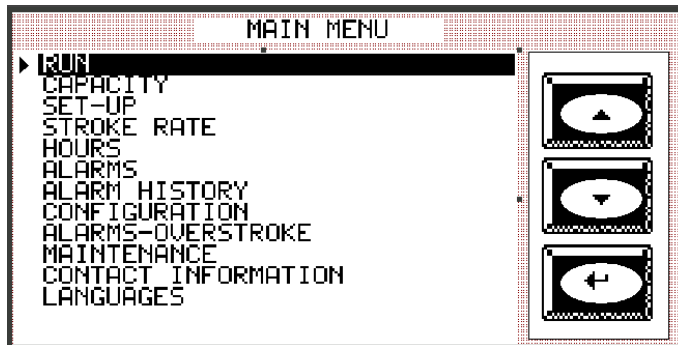

1.5 Safety

The high pressure waterjet cutting system is a high energy cutting tool capable of cutting many dense or strong materials. Do not touch or be exposed to high pressure water. High pressure water will penetrate all parts of the human body. The liquid stream and the material ejected by the extreme pressure can result in severe injury.

All personnel operating, servicing or working near the waterjet cutting equipment shall adhere to the following safety precautions, as well as the applicable plant safety precautions.

- Only KMT factory trained, qualified personnel shall service and maintain the equipment.
- The operator shall practice and promote safety at all times to avoid potential injury and unnecessary downtime.
- The work area around the equipment shall be clean and free of debris and oil spills.
- All protective guards, shields or covers shall be in place on the equipment at all times.
-  Safety glasses and ear protection shall be worn when operating or working near the equipment.

Lockout/Tagout Procedure

This lockout/tagout procedure is designed to protect all employees from injuries caused by the unexpected energizing or startup of the machine, or the release of stored energy during service and maintenance.

This is accomplished with energy isolating devices that prevent the transmission or release of energy. An energy source is any source of electrical, mechanical, hydraulic, pneumatic, chemical, thermal, or other energy source that could cause injury to personnel.

A lockout device utilizes a lock and key to hold an energy isolating device in the safe position and prevents the machine from being energized. A tagout device is a prominent warning device that can be securely attached to the machine warning personnel not to operate the energy isolating device. This procedure requires the combination of a lockout device and a tagout device.

The lockout/tagout procedure applies to any employee who operates and/or performs service or maintenance on the machine. Before any maintenance or repairs are performed, the machine shall be isolated, and rendered inoperative as follows.

1. Shut down the machine by pressing the STOP button, and open the high pressure cutting water valve to bleed the water and hydraulic pressure from the system.
2. Disconnect, lockout and tag the main, customer supplied, power source.
3. Lockout and tag the circuit breaker/disconnect on the electrical enclosure door.
4. Close, lockout and tag the manual shutoff valves for all service connections: cutting water in, cooling water in and out, and air.

Warning Labels

Warning labels are posted on the machine to indicate potential hazards. The operator and service personnel shall pay particular attention to these warning labels. Table 1-2 describes the necessary precautions and provides the part number required to order replacement labels.

Table 1-2
Warning Label Precautions

1		The electrical enclosure and motor junction boxes can present an electrical shock hazard. Always disconnect and lockout the main power before opening the enclosure.
P/N 05114962		Always disconnect and lockout the main power and the circuit breaker/disconnect on the electrical enclosure door before performing any type of maintenance
2		The surface of high pressure water and hydraulic components becomes hot during normal operation. Failed, or failing components, can become extremely hot during operation.
P/N 05114970		

Table 1-2
Warning Label Precautions

3		<p>Ensure that all protective guards, shields or covers are in place on the equipment at all times. Never operate the pump with the guards removed.</p>
	<p>P/N 80082209</p>	
4		<p>High pressure water and/or hydraulic pressure can remain in the system even when the pump has been shut off. All pressure can be safely bled from the system by opening the high pressure cutting water valve for a few seconds after shutting off the pump.</p>
	<p>P/N 05098017</p>	<p>Pressing the EMERGENCY STOP button turns the control power to the intensifier off, stops the pump and bleeds the high pressure water through the safety dump valve.</p> <p>Depressurization of the high pressure system creates a loud hissing sound when the dump valve opens. The sound fades quickly as the pressure drops.</p>
5		<p>Drip pans facilitate maintenance by supporting the high pressure cylinder assembly during removal and installation.</p> <p>The drip pans are not designed to support personnel. Do not stand or climb on the drip pans.</p>
	<p>P/N 20434074</p>	
6		<p>All personnel involved in the installation, operation and/or service of the intensifier must carefully read, understand and follow the procedures in this manual to avoid creating unsafe conditions, risking damage to the equipment, or personal injury.</p>
	<p>P/N 20415794</p>	

Safety precautions and warnings for specific procedures are emphasized throughout this manual as illustrated in the following examples. These precautions must be reviewed and understood by operating and maintenance personnel prior to installing, operating or servicing the machine. Adherence to all Warnings, Cautions and Notes is essential to safe and efficient service and operation.



Warnings emphasize operating or service procedures, or conditions that can result in serious personal injury or death.



Cautions emphasize operating or service procedures, or conditions that can result in equipment damage or impairment of system operation.

NOTE

Notes provide additional information that can expedite or improve operating or service procedures.

Emergency Medical Treatment

An emergency medical card is included in the binder of this manual. This information should be used to aid in the treatment of a waterjet injury. Additional cards may be obtained by contacting KMT Waterjet Systems using the address or telephone number shown on the card.

Medical Alert

This card is to be carried by personnel working with high pressure waterjet equipment. Obtain medical treatment immediately for ANY high pressure waterjet injuries.

**KMT Waterjet Systems
635 West 12th Street
Baxter Springs, KS 66713
(620) 856-2151**

This person has been working with water jetting at pressures to 60,000 psi (374MPa, 4,137 bar, 3867 Kg/cm²) with a jet velocity of 3,000 fps (914 mps). Foreign material (sand) may have been injected with water. Unusual infections with microaerophilic organisms occurring at lower temperatures have been reported, such as gram negative pathogens as are found in sewage. Bacterial swabs and blood cultures may therefore be helpful. This injury must be treated as an acute surgical emergency and be evaluated by a qualified surgeon. Circulation may be compromised, therefore, DO NOT APPLY HEAT TO INJURED PART. For first aid: (1) Elevate injured part (2) Antibiotics (3) Keep injured person NPO.



1.6 Worldwide Product Support

The KMT Waterjet Customer Service Department is available to answer your questions regarding equipment installation and service. Technical assistance is available by phone and on-site support is available on request.

On-site technical assistance is available during equipment installation and startup. Additionally, technical support for service and maintenance issues and training of operators and maintenance personnel is available. Periodic training sessions are also conducted at KMT Waterjet and customer facilities.

Contact the KMT Waterjet Customer Service Department for additional information.

USA Customer Service Department

KMT Waterjet Systems
PO Box 231
635 West 12th Street
Baxter Springs, KS 66713
USA

Phone: (800) 826-9274
Fax: (620) 856-2242
Email: wj.service@kmtwaterjet.com
Email: wj.parts@kmtwaterjet.com

Europe Technical Manager

KMT Waterjet Systems GmbH
Wasserstrahl-Schneidetechnik
Auf der Laukert 11
D-61231 Bad Nauheim
Germany

Phone: +49-6032-997-117
Fax: +49-6032-997-270
Email: order.service@kmt-waterjet.com

1.7 Spare Parts

KMT Waterjet maintains a well-stocked Spare Parts Department, staffed by trained, knowledgeable personnel. If required, emergency shipment is available. Contact the Customer Service Department to order spare parts, or for additional information.

1.8 Manual Organization

This manual contains operating and maintenance procedures for the complete SL-V series. Information is organized as follows:

- Section 1, Introduction, provides an overview of equipment features and options, a brief operational overview, details regarding safety issues and contact information for product support.
- Section 2, Installation, details installation requirements and procedures. Systematic guidelines for commissioning the intensifier are also provided.
- Section 3, Maintenance, highlights routine and preventive maintenance requirements. Precautions associated with high pressure cutting equipment are also reviewed.



- Section 4, Operation, explains the control functions and the display panel where operating parameters are set and monitored.
- Sections 5 through 9 are specific to each individual system. Each section contains a detailed description of the principles of operation and the function of each system, as well as routine maintenance procedures associated with the system.
- Section 10, Troubleshooting, is a comprehensive guide containing the information required to diagnose problems and repair the machine.
- Section 11, Specifications, contains a comprehensive list of equipment specifications; a detailed discussion of water quality standards and treatment guidelines; as well as horsepower requirements for various orifice sizes.
- Section 12, Parts List, contains part numbers, descriptions and drawings to facilitate the ordering of replacement parts.

1.9 Equipment and Service Manual Questionnaire

We are interested in your impression of the KMT Waterjet System recently installed at your location. Your comments and recommendations will aid us in our continuing goal to improve our products, and make our technical information more useful to our customers.

At your convenience, please take a few minutes to complete the following questionnaire, and return it to the applicable Customer Service Department listed above.



Equipment and Service Manual Questionnaire

1. General Appearance

Was the unit received in good condition? Yes No

Comments: _____

Is the unit a convenient size? Yes No

2. Controls

Are the controls user friendly? Yes No

Is the unit easy to operate? Yes No

Comments: _____

3. Performance

Does the unit perform smoothly and meet your expectations? Yes No

Does the unit run quietly? Yes No

Comments: _____

4. Did the installation and startup go smoothly?

Yes No

Comments: _____

5. What features do you consider the most significant?

Quiet operation _____

Appearance _____

Performance/Operation _____

Repair/Maintenance _____

Other _____

6. What areas could be improved?

Appearance _____

Performance _____

Serviceability _____

Other _____



7. Manual Organization

Does the Table of Contents help you find topics easily? Yes No

Comments: _____

Is the information well organized? Yes No

Comments: _____

Is the page layout suitable for the material being presented? Yes No

Comments: _____

8. Graphics

Are the illustrations suitable for the material being presented? Yes No

Comments: _____

9. Text

Does the information adequately explain how to operate and service the equipment? Yes No

Comments: _____

Are there paragraphs or procedures you feel need clarification? Please identify them by page number and add your comments. Yes No

Comments: _____

Is there anything you would add or delete to make the manual more useful? Yes No

Comments: _____

Is there any information that should receive more emphasis? Yes No

Comments: _____

Name _____ Title _____

Company _____ Date _____

Address _____



Terms and Conditions of Sale

1. General

The Terms and Conditions of Sale outlined herein shall apply to the sale by KMT Waterjet Systems Inc. (hereinafter referred to as Company) of products, equipment and parts relating thereto (hereinafter referred to as Equipment). Unless prior written agreement is reached, it shall be understood that the Company's proceeding with any work shall be in accordance with the terms and conditions outlined herein

The Company will comply with applicable laws and regulations in effect on the date of the Company's proposal as they may apply to the manufacture of the Equipment. Compliance with any local governmental laws or regulations relating to the location, use or operation of the Equipment, or its use in conjunction with other equipment, shall be the sole responsibility of the Purchaser.

2. Title and Risk of Loss

Title and risk of loss or damage to the Equipment shall pass to the Purchaser upon tender of delivery F.O.B. manufacturing facility unless otherwise agreed upon by the parties, except that a security interest in the Equipment shall remain in the Company, regardless of mode of attachment to realty or other property, until full payment has been made therefor. Purchaser agrees upon request to do all things and acts necessary to perfect and maintain said security interest and shall protect Company's interest by adequately insuring the Equipment against loss or damage from any cause wherein the Company shall be named as an additional insured.

3. Assignment

Neither party shall assign or transfer this contract without the prior written consent of the other party. The Company however shall be permitted to assign or transfer, without the prior written consent of the Purchaser, the Company's right to receive all or any portion of the payment due from the Purchaser under this contract.

4. Delivery and Delays

Delivery dates shall be interpreted as estimated and in no event shall dates be construed as falling within the meaning of "time is of the essence".

The Company shall not be liable for any loss or delay due to war, riots, fire, flood, strikes or other labor difficulty, acts of civil or military authority including governmental laws, orders, priorities or regulations, acts of the Purchaser, embargo, car shortage, damage or delay in transportation, inability to obtain necessary labor or materials from usual sources, faulty forgings or castings, or other causes beyond the reasonable control of the Company. In the event of delay in performance due to any such cause, the date of delivery or time for completion will be adjusted to reflect the actual length of time lost by reason of such delay. The Purchaser's receipt of Equipment shall constitute a waiver of any claims for delay.

5. Taxes

The price does not include any present or future Federal, State, or local property, license, privilege, sales, use, excise, gross receipts or other like taxes or assessments which may be applicable to, measured by, imposed upon or result from this transaction or any services performed in connection therewith. Such taxes will be itemized separately to Purchaser, who shall make prompt payment to the Company. The Company will accept a valid exemption certificate from Purchaser, if applicable. If such exemption certificate is not recognized by the governmental taxing authority involved, Purchaser agrees to promptly reimburse the Company for any taxes covered by such exemption certificate which the Company is required to pay.

6. Set Offs

Neither Purchaser nor any affiliated company or assignee shall have the right to claim compensation or to set off against any amounts which become payable to the Company under this contract or otherwise.

7. Patents

The Company shall defend any Suit or proceeding brought against the Purchaser and shall pay any adverse judgment entered therein so far as such suit or proceeding is based upon a claim that the use of the Equipment manufactured by the Company, and furnished under this contract constitutes infringement of any patent of the United States of America, providing the Company is promptly notified in writing and given authority, information and assistance for defense of same; and the Company shall, at its option, procure for the Purchaser the right to continue to use said Equipment, or to modify it so that it becomes non-infringing, or to replace the same with non-infringing equipment, or to remove said Equipment and to refund the purchase price. The foregoing shall not be construed to include any agreement by the Company to accept any liability whatsoever in respect to patents for inventions including more than the Equipment furnished hereunder or in respect of patents for methods and processes to be carried out with the aid of said Equipment. The foregoing states the entire liability of the Company with regard to patent infringement.

8. Warranty

The Company warrants that the Equipment manufactured by it and delivered hereunder will be free of defects in material and workmanship for a period of twelve months from the date of placing the Equipment in operation or eighteen months from the date of shipment, whichever shall first occur. The Purchaser shall be obligated to promptly report any failure to conform to this warranty, in writing to the company within said period, whereupon the Company shall, at its option, correct such nonconformity, by suitable repair to such Equipment or, furnish a replacement part F.O.B. point of shipment, provided the Purchaser has stored, installed, maintained and operated such Equipment in accordance with good industry practices and has complied with specific recommendations of the Company. Accessories or equipment furnished by the Company, but manufactured by others, shall carry whatever warranty the manufacturers have conveyed to the Company and which can be passed on to the Purchaser. The Company shall not be liable for any repairs, replacements, or adjustments to the Equipment or any costs of labor performed by the Purchaser or others without the Company's prior written approval.

The effects of corrosion, erosion and normal wear and tear are specifically excluded. Performance warranties are limited to those specifically stated within the Company's proposal. Unless responsibility for meeting such performance warranties are limited to specified shop or field tests, the Company's obligation shall be to correct in the manner and for the period of time provided above.

THE COMPANY MAKES NO OTHER WARRANTY OR REPRESENTATION OF ANY KIND WHATSOEVER, EXPRESSED OR IMPLIED, EXCEPT THAT OF TITLE, AND ALL IMPLIED WARRANTIES OF MERCHANTABILITY AND FITNESS FOR A PARTICULAR PURPOSE, ARE HEREBY DISCLAIMED.

Correction by the Company of nonconformities whether patent or latent, in the manner and for the period of time provided above, shall constitute fulfillment of all liabilities of the Company for such nonconformities, whether based on contract warranty, negligence, indemnity, strict liability or otherwise with respect to or arising out of such Equipment.



The Purchaser shall not operate Equipment which is considered to be defective, without first notifying the Company in writing of its intention to do so. Any such use of Equipment will be at the Purchaser's sole risk and liability.

9. Limitation of Liability

THE REMEDIES OF THE PURCHASER SET FORTH HEREIN ARE EXCLUSIVE, AND THE TOTAL LIABILITY OF THE COMPANY WITH RESPECT TO THIS CONTRACT OR THE EQUIPMENT AND SERVICES FURNISHED HEREUNDER. IN CONNECTION WITH THE PERFORMANCE OR BREACH THEREOF, OR FROM THE MANUFACTURE, SALE, DELIVERY, INSTALLATION, REPAIR OR TECHNICAL DIRECTION COVERED BY OR FURNISHED UNDER THIS CONTRACT, WHETHER BASED ON CONTRACT WARRANTY, NEGLIGENCE, INDEMNITY, STRICT LIABILITY OR OTHERWISE, SHALL NOT EXCEED THE PURCHASE PRICE OF THE UNIT OF EQUIPMENT UPON WHICH SUCH LIABILITY IS BASED.

THE COMPANY AND ITS SUPPLIERS SHALL IN NO EVENT BE LIABLE TO THE PURCHASER, ANY SUCCESSORS IN INTEREST OR ANY BENEFICIARY OR ASSIGNEE OF THIS CONTRACT FOR ANY CONSEQUENTIAL, INCIDENTAL, INDIRECT, SPECIAL OR PUNITIVE DAMAGES ARISING OUT OF THIS CONTRACT OR ANY BREACH THEREOF, OR ANY DEFECT IN, OR FAILURE OF, OR MALFUNCTION OF THE EQUIPMENT HEREUNDER, WHETHER BASED UPON LOSS OF USE, LOST PROFITS OR REVENUE, INTEREST, LOST GOODWILL, WORK STOPPAGE, IMPAIRMENT OF OTHER GOODS, LOSS BY REASON OF SHUTDOWN OR NON-OPERATION, INCREASED EXPENSES OF OPERATION, COST OF PURCHASE OF REPLACEMENT POWER OR CLAIMS OF PURCHASER OR CUSTOMERS OF PURCHASER FOR SERVICE INTERRUPTION WHETHER OR NOT SUCH LOSS OR DAMAGE IS BASED ON CONTRACT, WARRANTY, NEGLIGENCE, INDEMNITY, STRICT LIABILITY OR OTHERWISE.

10. Nuclear Liability

In the event that the Equipment sold hereunder is to be used in a nuclear facility, the Purchaser shall, prior to such use, arrange for insurance or governmental indemnity protecting the Company against liability and hereby releases and agrees to indemnify the Company and its suppliers for any nuclear damage, including loss of use, in any manner arising out of a nuclear incident, whether alleged to be due, in whole or in part to the negligence or otherwise of the Company or its suppliers.

11. Governing Law

The rights and obligations of the parties shall be governed by the laws of the State of Delaware excluding any conflicts of law provisions. The United Nations Convention on Contracts for the International Sale of Goods shall not apply to this agreement.

12. Export Control

The Company's products are U.S. origin items and subject to U.S. export control laws, including the Export Administration Regulations. Customer agrees that it will comply with U.S. export control laws and will not export, re-export, transfer, re-transfer, sell, re-sell, otherwise divert Company products contrary to U.S. law. Customer further agrees that it will obtain all required export licenses.

13. Execution

The Company shall not be bound by any contract or any modification thereto until approved in writing by an officer of the Company. The contract, when so approved shall supersede all previous communications, either oral or written.



Terms and Conditions

Part Sales

1. General

The Terms of Conditions outlined herein shall apply to the sales of parts by KMT Waterjet Systems (hereinafter referred to as Company.) No additional or contrary terms shall be binding upon the Company unless agreed to in writing.

2. Schedule Dates and Delays

Schedule dates are approximate and neither party shall be liable for loss, damage, detention, or delay due to war, riots, civil or military authority including governmental laws, orders, priorities or regulations, acts of the other party, embargo, car shortage, wrecks or delay in transportation, inability to obtain necessary labor, materials or manufacturing facilities from usual sources, faulty forgings or castings, or other causes beyond the reasonable control of such party.

Should the Purchaser request special shipping instruction such as exclusive use of shipping facilities, including air freight when common carrier has been quoted and before a change to the order is received by the Company, the additional charges will be honored by Purchaser.

3. Taxes

The prices provided for herein do not include any present or future Federal, State, Municipal sales, use, excise, gross receipts, property, or other similar type tax with respect to any material or equipment covered hereby. If the Company is required by applicable law or regulation to pay or collect any such type tax or taxes on account of this transaction or the material or equipment covered hereby, then such amount of tax shall be paid by the Purchaser in addition to the prices herein provided for.

4. Warranty

The Company warrants that parts manufactured by it will be as specified and will be free from defects in materials and workmanship, the Company's liability under this warranty shall be limited to the repair or replacement of any part F.O.B. point of shipment which was defective at the time of shipment, provided the Purchaser notifies the Company in writing of any such defect promptly upon discovery, but in no event later than six (6) months from the date of shipment of such part by the Company.

Warranties applicable to material and equipment supplied by the Company but wholly manufactured by others shall be limited to the warranties extended to the Company by the manufacturer which are able to be conveyed to the Purchaser.

The Company makes no performance warranty and the effects of corrosion, erosion and normal wear and tear are specifically excluded from the Company's warranty.

THE COMPANY MAKES NO OTHER WARRANTY OR REPRESENTATION OF ANY KIND WHATSOEVER, EXPRESSED OR IMPLIED, EXCEPT THAT OF TITLE, AND ALL IMPLIED WARRANTIES, INCLUDING ANY WARRANTY OF MERCHANTABILITY AND FITNESS FOR A PARTICULAR PURPOSE, ARE HEREBY DISCLAIMED.

5. Limitation of Liability

The remedies of the Purchaser set forth herein are exclusive, and the liability of the Company with respect to this order shall not exceed the purchase price of the part upon which such liability is based.

The Company and its suppliers shall in no event be liable to the Purchaser, any successors in interest or any beneficiary of this order for any consequential, incidental, indirect, special or punitive damages arising out of this order or any breach thereof, whether based upon loss of use, lost profits or revenue interest, lost goodwill, work stoppage, impairment of other goods, loss by reason of shutdown or non-operation, increased expenses of operation, cost of purchase of replacement power or claims of Purchaser or customers of Purchaser for service interruption, whether or not such loss or damage is based on contract, warranty, negligence, indemnity, strict liability or otherwise.

6. Nuclear Liability

In the event that the parts sold hereunder are to be used in a nuclear facility the Purchaser shall, prior to such use, arrange for insurance or governmental indemnity, protecting the Company against liability and hereby suppliers for any nuclear damage, including loss of use, in any manner arising out of a nuclear incident, whether alleged to be due in whole or in part to the negligence or otherwise of the Company or its suppliers.

7. Export Control

The Company's products are U.S. origin items and subject to U.S. export control laws, including the Export Administration Regulations. Customer agrees that it will comply with U.S. export control laws and will not export, re-export, transfer, re-transfer, sell, re-sell, otherwise divert Company products contrary to U.S. law. Customer further agrees that it will obtain all required export licenses.



Terms LD-146 Domestic Service Supervisor

When KMT Waterjet Systems (hereinafter called the Company) provides the Services of a Service Supervisor (hereinafter called the Supervisor) to consult with and advise the Purchaser in the installation, starting up and/or overhaul or maintenance of equipment of KMT Waterjet manufacture, such Supervisor shall not be responsible for the procurement of labor or mechanical work performed by others. The Service Supervisor's services shall be furnished under the following conditions:

1. All necessary workmen (common, semi-skilled and skilled), together with proper labor supervision shall be furnished by the Purchaser, at his expense. Qualified Support labor must be available to the Supervisor at all times during the Supervisor's work hours. **The Supervisor is prohibited by the Company from working alone.**

2. All necessary utilities shall be furnished by the Purchaser, at his expense.

3. The Supervisor will expect to work consecutive days until the contracted work is complete. For any day the Supervisor is available for work and is denied access, with the exception of national holidays, the Purchaser will be invoiced by the Company for eight (8) hours at the KMT rate in effect at the time of service, plus associated living expenses.

4. The Purchaser shall provide all tools and equipment required for any installation or service work. The Company's Supervisor may bring with him, or ship to the jobsite, special tools which are and shall remain Company property. If such tools are too heavy for transport by the Supervisor, the Purchaser shall assist in arranging for their return to a location designated by the Company at the completion of the services.

5. The Company shall be reimbursed by the purchaser for all transportation costs for any required special tools or equipment, plus replacement costs for any of these items which are not returned to the Company at the completion of the services.

6. The Company agrees that the Supervisor will provide Best Efforts in effecting repairs to equipment supplied by the Company, but provides no guarantee that such Best Efforts will result in restoration of proper operation of equipment the Supervisor is contracted to repair.

7. The Supervisor shall be suitably covered with insurance in the areas of Worker's Compensation, Public Liability and Automobile Insurance where the use of a vehicle is required. Certificates confirming this insurance coverage are obtainable upon request. The Company shall in no event be liable for any loss recoverable by the Purchaser under insurance policies covering Purchaser's property.

8. The Company accepts no responsibility for material or the acts of men furnished by the Purchaser. The Company is not responsible for the rate of progress or the date of completion of the work nor for incorrect operation or damage incurred due to improper storage or handling.

9. The Company shall be permitted to assign all or any portion of its performance under this Contract to a selected Professional Service organization, without the prior consent of the Purchaser.

10. The Company and its affiliates or suppliers shall in no event be liable to the Purchaser, any successors in interest or any beneficiary of this Contract for any consequential, incidental, indirect, special or punitive damages arising out of this Contract or any breach thereof, or any defect in, or failure of equipment or machinery, whether based upon loss of use, lost profits or revenue, interest, lost good will, work stoppage, impairment of other goods, loss by reason of shutdown or non-operation, increased expenses of operation, cost of purchase of replacement power or claims of Purchaser or customers of Purchaser for service interruption, whether or not such loss or damage is based on contract, warranty, negligence, indemnity, strict liability, or otherwise. **The total liability of the Company under this Contract in all other respects shall be limited to the purchase price of the services furnished hereunder.**



Terms LD-147 International Service Supervisor

When KMT Waterjet Systems (hereinafter called the Company) provides the Services of a Service Supervisor (hereinafter called the Supervisor) to consult with and advise the Purchaser in the installation, starting up and/or overhaul or maintenance of equipment of KMT Waterjet manufacture, such Supervisor shall not be responsible for the procurement of labor or mechanical work performed by others. The Service Supervisor's services shall be furnished under the following conditions:

1. The Purchaser shall pay the Company for the services of said Supervisor per company service rates and terms in effect at the time the contracted work is complete. Any day the Supervisor is available for work and is denied access, with the exception of national holidays, will be invoiced eight (8) hours at the company service rate in effect on that day plus associated living expenses.

2. The Company shall also be reimbursed by the Purchaser for: (a) The Supervisor's transportation expenses en-route from the Company's facility or equivalent starting point to the jobsite and return thereto; (b) Any processing costs for passports, inoculations, etc., necessarily incurred in preparation for travel, as well as entry or exit fees, required to be paid as a result of such travel; (c) Subsistence and quarters for the Supervisor, comparable to those furnished the Purchaser's Superintendent. In the event the Purchaser shall decide to provide living accommodations to the Supervisor, such accommodations shall be equal to those provided for the Purchaser's Superintendent and shall not be less than the maximum accommodations furnished supervisory personnel of other contractors at Purchaser's jobsite; (d) Local transportation costs to and from the jobsite (taxi, auto rental, etc.); (e) All living expenses as detailed in (c) and (d) above for days where the supervisor has been denied access; (f) Transportation costs for any required special tools or equipment, plus costs for any of these items which are not returned to the Company at the completion of the services.

3. In the event that the Supervisor of the Company becomes obligated to pay any local taxes, levies, imposts, social charges, withholdings or duties of any nature, (hereinafter collectively called Taxes) as a result of services rendered herein, the Purchaser shall assume and pay such Taxes directly to the local tax authorities, or alternatively, immediately reimburse the Company for such Taxes, together with an amount which takes into account any Taxes due on account of a reimbursement including any taxes thereon. Purchaser shall pay any tax penalties or late charges which may be due in connection therewith. In the event the Purchaser pays such Taxes directly to the local tax authorities, it shall immediately furnish the Company with appropriate receipts evidencing such payment.

4. All necessary workmen (common, semi-skilled and skilled), together with proper labor supervision shall be furnished by the Purchaser, at his expense. All necessary utilities shall also be furnished by the Purchaser, at his expense. Qualified support labor must be made available to the Supervisor at all times during the Supervisor's work hours. **The Supervisor is prohibited by the Company from working alone.**

5. The Purchaser shall provide all tools and equipment required for any installation or service work. The Company's Supervisor may bring with him, or ship to the jobsite, special tools which are and shall remain Company property. If such tools are too heavy for transport by the Supervisor, the Purchaser shall assist in arranging for their return to a location designated by the Company at the completion of the services.

6. The Purchaser shall provide suitable office facilities convenient to the jobsite for work assignments exceeding thirty (30) days; facilities to include heat, light, desk, chair, telephone, and safe storage space for drawings and tools.

7. The Supervisor shall be properly covered with insurance in the areas of Worker's Compensation, Public Liability and Automobile Insurance where the use of a vehicle is required. Certificates confirming this insurance coverage are obtainable upon request. The Company shall in no event be liable for any loss recoverable by the Purchaser under insurance policies covering Purchaser's property.

8. The Company agrees that the Service Supervisor will provide Best Efforts in effecting repairs to equipment supplied by the Company, but provides no guarantee that such Best Efforts will result in restoration of proper operation of equipment the Service Supervisor is contracted to repair.

9. The Company accepts no responsibility for material or the acts of men furnished by the Purchaser. The Company is not responsible for the rate of progress or the date of completion of the work nor for incorrect operation or damage incurred due to improper storage or handling.

10. The Company shall be permitted to assign all or any portion of this Contract to a selected Professional Service organization without the prior consent of the Purchaser.

11. The Company reserves the right to replace a Service Supervisor after a 30 day period, in which event the Purchaser will pay to the Company associated expenses for the Supervisor's return trip. The replacement Supervisor will be furnished on the same basis as outlined herein.

12. If the services of a Supervisor are required for a period longer than six (6) months and the Company authorizes such Supervisor to be accompanied by members of his immediate family, the Purchaser will pay the Company for round trip expenses in connection with travel between the jobsite and the respective normal place of residence of such members of the immediate family of the Supervisor.

13. The Purchaser agrees that it will render all assistance to insure the Supervisor will be permitted prompt and safe exit from the country in which the services are performed.

14. The Company shall not be bound by or required to adhere to any term or provision of a purchase order, quotation, bid, letter of credit, or like document, or any provision of law, regulation or custom, which would cause the Company or any of its parents or affiliates to be in violation of the export laws, taxing statutes or regulations of the country of citizenship of the Supervisor or other country having jurisdiction over this contract.

15. The Company and its affiliates or suppliers shall in no event be liable to the Purchaser, any successors in interest or any beneficiary of this Contract for any consequential, incidental, indirect, special or punitive damages arising out of this Contract or any breach thereof, or any defect in, or failure of equipment or machinery, whether based upon loss of use, lost profits or revenue, interest, lost goodwill, work stoppage, impairment of other goods, loss by reason of shutdown or non-operation, increased expenses of operation, cost of purchase of replacement power or claims of Purchaser or customers of Purchaser for service interruption, whether or not such loss or damage is based on contract, warranty, negligence, indemnity, strict liability, or otherwise. **The total liability of the Company under this Contract in all other respects shall be limited to the purchase price of the services furnished hereunder.**



SECTION 2

INSTALLATION

2.1 Overview

Installation and commissioning requirements and procedures are detailed in this section. These procedures require a thorough understanding of the individual components and systems, safety issues, and the overall operation of the intensifier.

All personnel involved in the installation, operation and/or service of the pump must carefully review this manual prior to installing and commissioning the machine.

The Technical Service Department at KMT Waterjet Systems is available to assist in the installation and commissioning process. Service and repair training for maintenance personnel is also available.

2.2 Installation Summary

The following summary lists the procedures required for the installation and commissioning of the machine. Details and requirements for each item are discussed in this section.

- Upon receipt, the machine must be uncrated and moved into position on a level surface.
- Properly sized power drops with fused disconnects must be installed.
- A pneumatic drop with a manual shutoff valve and regulator for the air connection must be installed.
- Plumbing and manual shutoff valves for the inlet and outlet cooling water, and the inlet and outlet cutting water must be installed.

Incoming source water must meet specific water quality standards, flow rates and pressure requirements. It may be necessary to install water conditioning and/or pressure boosting equipment to meet these water purity and pressure requirements.

- Drain water plumbing must be suitably located and installed for the proper disposal of wastewater.
- High pressure tubing runs from the intensifier to the cutting station must be installed with the appropriate mountings, support brackets and hardware.
- Wiring must be installed and connected between the intensifier and the cutting station control system.
- The machine must be commissioned and tested.

2.3 Site Requirements

The pump must be installed indoors where air borne dust and contaminants are minimal. The ambient temperature should be between 40° F (5° C) and 100° F (38° C), with a maximum relative humidity of 95%.

Refer to Table 2-1, Equipment Dimensions and Weight, to establish a suitable installation site. A minimum clearance of 36 inches (914 mm) should be provided on all sides of the machine to facilitate service.

Figure 2-1: Equipment Dimensions

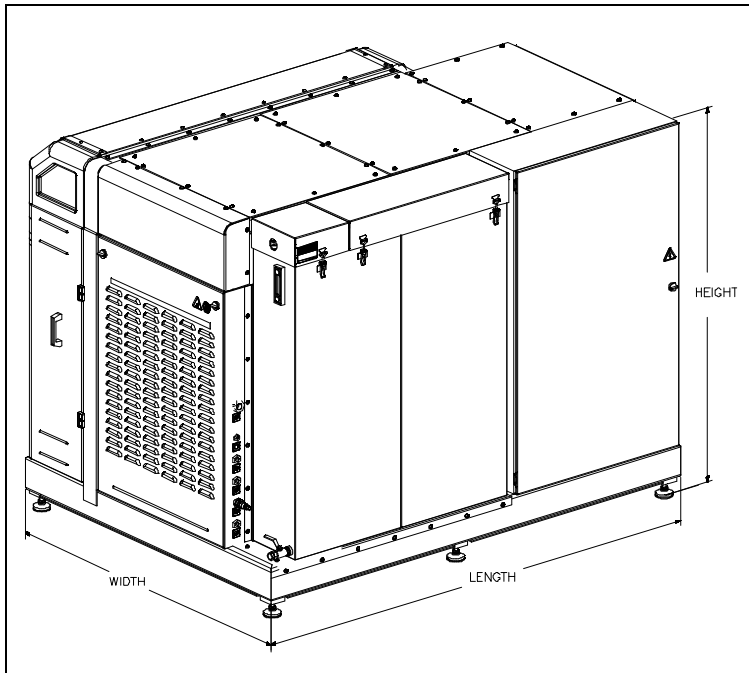

**Table 2-1
Equipment Dimensions and Weight**

Horsepower	Length	Width	Height	Weight
150-200 HP	90.75" (2,305 mm)	66.75" (1,695 mm)	70.00" (1,778 mm)	8,820 lbs (4,000 kg)*
Redundant Model				
150-200HP				9,220 lbs (4,182 kg)*

** Note: When the hydraulic reservoir is full. Subtract 1,000 lbs (454 kg) if the reservoir is dry.*

Transporting

The weight of the machine is not evenly distributed from one end to the other. Do not attempt to lift the machine from either end. Note the warnings stamped on the crate. The center of gravity is clearly identified on the sides of the crate. The forklift should be positioned accordingly.

When the machine has been removed from the crate, note the position of the fork guides on the bottom of the machine. The guides are positioned in relationship to the center of gravity to balance the weight on the forklift. The machine should be lifted from the front side.

Figure 2: Fork Guides

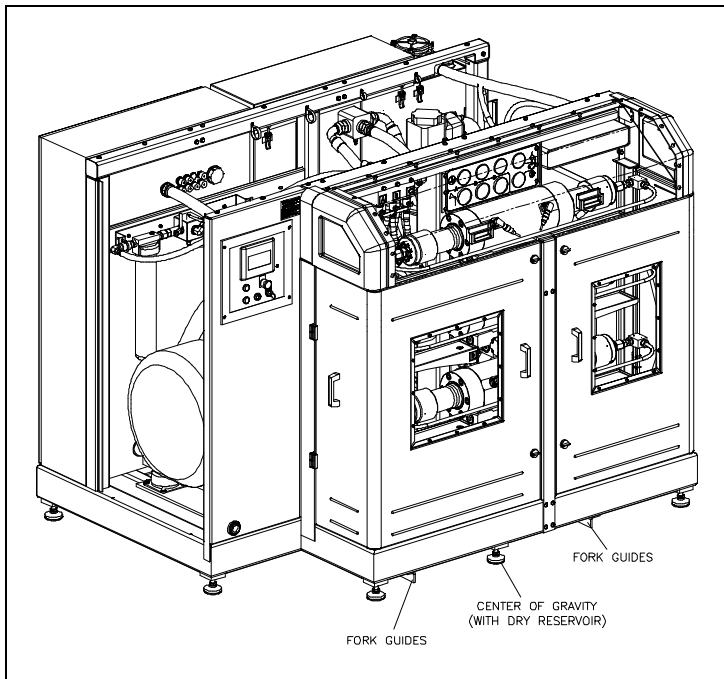

The machine **must** be lifted from the bottom. **Do not** attempt to lift the machine from the top structure.

2.4 Power Requirements

Power supplied to the pump and wiring for remote control must comply with local, regional and national electrical codes. Service voltage and ampacity must meet the requirements of the specific model. Voltage fluctuations in excess of +/- 10 percent of nominal voltage may damage the machine and void the warranty. Refer to Table 2-2, Ampacity and Power Voltage Requirements.

Table 2-2
Ampacity and Power Voltage Requirements

Power Voltage	Motor Horsepower	Full Load Amps	Circuit Breaker Amps
460/3/60	150	166	225
400/3/50	200	259	275
460/3/60	200	225	350
575/3/50-60	200	198	350

2.5 Service Connections

The intensifier requires two incoming water sources, cooling water and cutting water; two drain lines, cooling water and wastewater; a high pressure discharge line, and an air supply line. All piping must comply with local, regional and national codes.



Thoroughly purge all supply plumbing prior to connection to remove any residue that could contaminate the system.

All service connections are made on the rear bulkhead of the machine as shown in Figure 2-3, Service Connections. Table 2-3 lists the fittings required and the dimensions for each interface connection.

With the exception of the wastewater drain line, manual shutoff valves should be installed for all connections. To facilitate service, the valves should be located as close as practical to the interface connection.

Figure 2-3: Service Connections

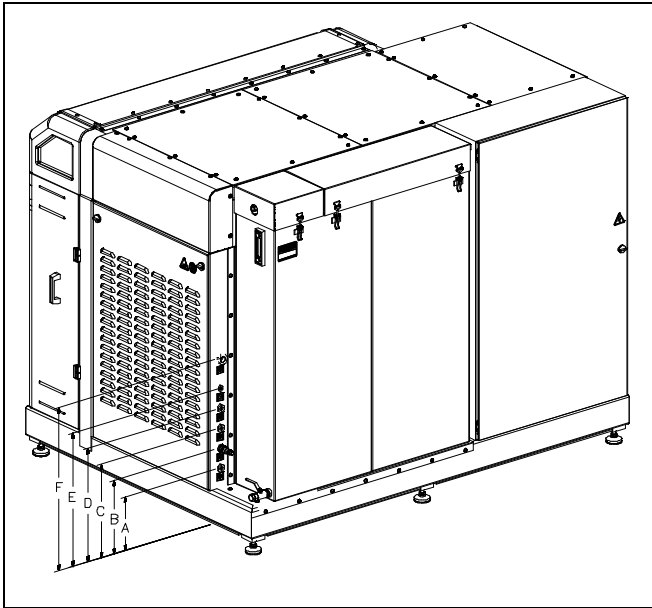

Table 2-3
Service Connections

		Connection	Height
A	Drain	1/2" NPT	10.75" (273 mm)
B	Cutting Water In	3/4" NPT	14.75" (375 mm)
C	Cooling Water In	1/2" NPT	18.75" (476 mm)
D	Cooling Water Out	1/2" NPT	22.75" (578 mm)
E	Plant Air In	1/4" NPT	26.75" (679 mm)
F	Cutting Water Out	9/16" HP	32.78" (833 mm)

Cooling Water

Inlet cooling water flows through the oil-to-water heat exchanger in the hydraulic system to control heat build-up in the hydraulic oil. The cooling water is then discharged through the cooling water out port to either the drain or routed to a customer supplied water chiller.

Cooling water supply piping must be sized to meet the flow and pressure requirements of the equipment. If municipal or well water is used for cooling, ensure the supply flow and pressure meet the requirements in Table 2-6, Service Connection Specifications.



If a facility-wide chilled water system is used for cooling, ensure there is a minimum of 35 psi (2.4 bar) pressure differential between the facility supply and discharge plumbing. Installation of an in-line pressure boosting pump may be necessary to provide adequate cooling flow. Dedicated chilled water systems should be sized according to pump horsepower as illustrated in Table 2-4, Chilled Water Systems.

Table 2-4
Chilled Water Systems
Cooling Requirements at Full Capacity

Horsepower	BTU/HR
150	57,300
200	77,000

Note: Coolant flow to the heat exchanger is regulated by the temperature of the contents in the hydraulic reservoir and will be shut off at times.

Cutting Water

Inlet cutting water is filtered and routed to the intensifiers where it is pressurized and delivered to the cutting head. The cutting water supply must meet the minimum water quality standards outlined in Section 11, Specifications. Poor water quality will drastically shorten component life and void the warranty.

Cutting water supply piping must be sized to meet the flow and pressure requirements listed in Table 2-6. Only PVC, copper or rubber hoses should be used between the cutting water source and the machine.

The inlet water must be maintained at a minimum pressure of 35 psi (2.4 bar) at all times. If the facility water pressure is below, or can fall below 35 psi (2.4 bar), a water pressure booster pump is required.

NOTE

The machine will not start if inlet cutting water pressure is below 30 psi (2 bar).

Drain

Cutting water released through the safety dump valve when the emergency stop button is initiated is discharged from the drain port. The discharge is considered wastewater and must be piped to an appropriate location, i.e. a sewer line. The volume of water released will be minimal and does not require high pressure plumbing, however, piping must comply with local, regional and national codes.



Plant Air

The facility compressed air connection should provide clean, dry air regulated to 85 psi (5.9 bar). Air usage is minimal, normally less than 1 scf/m.

The following table provides specifications for each ISO air quality classification. KMT recommends adherence to Quality Class 4.

**Table 2-5
ISO Air Quality Classifications**

ISO Quality Class	Maximum Particle Size (microns)	Maximum Pressure Dew Point (water @ 100 psi)	Maximum Oil Content (Mg/m ³)
1	0.1	-94° F (-60° C)	0.01
2	1	-40° F (-40° C)	0.1
3	5	-4° F (-20° C)	1
4	15	+38° F (+3° C)	5
5	40	+45° F (+7° C)	25
6	--	+50° F (+10° C)	--

**Table 2-6
Service Connection Specifications**

	150 HP	200 HP
Cooling Water		
Maximum consumption at 75° F (24° C)	7.0 gpm (26.5 L/min)	9.0 gpm (34.1 L/min)
Minimum inlet pressure	35 psi (2.4 bar)	35 psi (2.4 bar)
Cutting Water		
Maximum consumption	12.0 gpm (45.5 L/min)	16.0 gpm (60.6 L/min)
Minimum inlet pressure	35 psi (2.4 bar) flowing	35 psi (2.4 bar) flowing
Compressed Air		
Minimum air pressure	85 psi (5.9 bar)	85 psi (5.9 bar)

2.6 Flow Requirements

Figure 2-4, Pressure Drop Values, illustrates the pressure drop for four different pipe sizes. The graph can be used to calculate the minimum source water pressure.

1. Enter the graph at the required GPM and note the pressure drop figures for the different pipe sizes.
2. Multiply the pressure drop (PSI/FT) by the length in feet of each pipe size used from the water source to the intensifier. Add the values together for a total pressure drop value.
3. Add 30 to the total pressure drop to determine the minimum flowing, source water pressure required to provide adequate supply to the intensifier.

Cutting water and cooling water capacity should be calculated separately. Note that the cutting water requirements represent instantaneous, not average, demand. **The machine will not start if the inlet cutting water pressure drops below 30 psi (2 bar).**

Figure 2-4: Pressure Drop Values

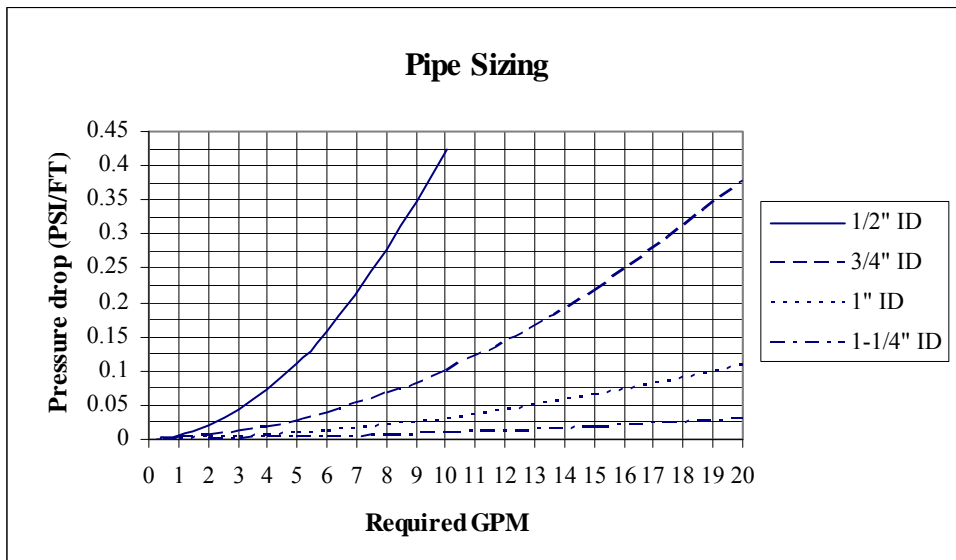

2.7 High Pressure Piping

High pressure piping is used to transport high pressure cutting water from the machine to the cutting station. High pressure piping and fittings must be properly rated and sized. When transporting high pressure water over long distances, tubing and fittings with an outside diameter of 9/16-inch are typically recommended. The large tubing size reduces vibration, strain and motion; as well as reducing pressure drop and pulsation.

NOTE

The volume of high pressure water generated by the 200 horsepower pump may require 3/4-inch tubing or parallel 9/16-inch tubing for long runs. Contact the service department at KMT Waterjet Systems for assistance.



High pressure tubing and fittings must be rated for 60,000 psi (4,136 bar). Failure to use properly rated components may result in component failure causing equipment damage, personal injury or death.

High pressure tubing lengths must be coned and threaded prior to installation. KMT Waterjet provides both hand and power tools for coning and threading high pressure tubing. Tool descriptions and part numbers are provided in Table 2-7.

Table 2-7
Coning and Threading Tools

	Part Number	
	Hand Tools	Power Tools
1/4" Coning Tool	05108832	05109897
3/8" Coning Tool	05108857	05109889
9/16" Coning Tool	05108840	05109871
3/4" Coning Tool	49832850	49832892
1/4" Threading Tool	05108865	05122742
3/8" Threading Tool	05108873	05120258
9/16" Threading Tool	05108881	05122759
3/4" Threading Tool	49832868	49832843
1/4" Tube Vise	05108782	
3/8" Tube Vise	05108790	
9/16" Tube Vise	05108774	
3/4" Tube Vise	49832876	

Measurements and Dimensions

Tubing must be cut to the proper length, both ends of the tubing must then be coned, threaded and deburred.

To determine the tube length, measure the distance between the fittings, and add two times the engagement allowance shown in Table 2-8. Table 2-9 lists the required cone and thread dimensions illustrated in Figure 2-6.

Figure 2-5: Tube Length

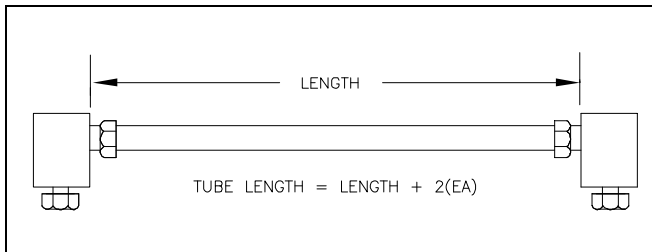

**Table 2-8
Engagement Allowance (EA)**

1/4" Tubing	0.49" (12.4 mm)
3/8" Tubing	0.68" (17.3 mm)
9/16" Tubing	0.86" (21.8 mm)

Figure 2-6: Cone and Thread Dimensions

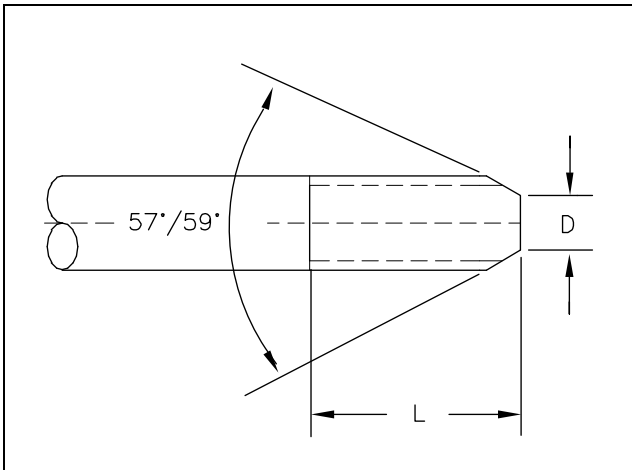
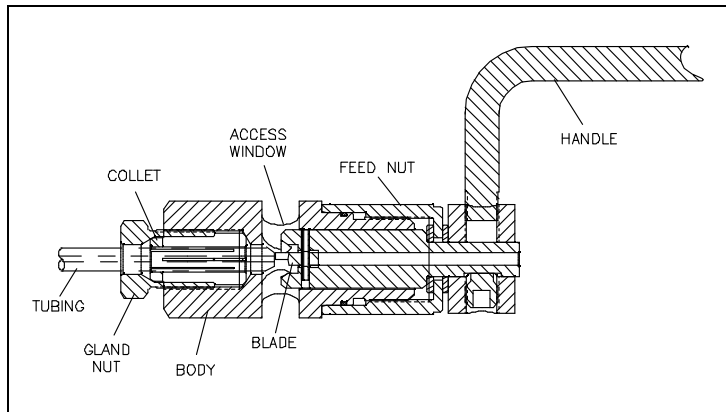

**Table 2-9
Cone and Thread Dimensions**

Tube OD	Tube ID	D (Maximum)	L (Maximum)	Thread UNF-LH
1/4" (6.35 mm)	0.083" (2.11 mm)	0.125" (3.2 mm)	0.562" (14.3 mm)	1/4" - 28
3/8" (9.52 mm)	0.125" (3.18 mm)	0.219" (5.6 mm)	0.750" (19.1 mm)	3/8" - 24
9/16" (14.29 mm)	0.188" (4.78 mm)	0.281" (7.1 mm)	0.938" (23.8 mm)	9/16" - 18
3/4" (19.05 mm)	0.250" (6.35 mm)	0.375" (9.5 mm)	1.160" (29.5 mm)	3/4" - 16

Hand Coning

Figure 2-7: Hand Coning Tool



1. Place the body of the coning tool in a vise allowing adequate clearance for the rotation of the cutter handle. Position the tool so the cutter handle is elevated slightly so the lubricant will flow to the cutting blades.
2. Turn the feed nut counter-clockwise to retract the cutting blades past the access window.
3. Loosen the gland nut and insert the tubing through the collet. The end of the tubing should just make contact with the cutting blades. Loosely tighten the gland nut to slightly grip the tubing.
4. Turn the feed nut counter-clockwise 1/4 turn to retract the cutting blades away from the tubing, and tighten the gland nut with a wrench.
5. Apply a liberal amount of cutting oil to the exposed end of the tubing, the cutting blades and through the lubrication channel at the cutter handle.

Apply cutting oil frequently and liberally throughout the cutting operation. A medium weight cutting oil with high sulfur content is recommended.

6. Turn the feed nut clockwise until the cutting blades contact the end of the tubing.
7. In a smooth, continuous motion, turn the cutter handle in a clockwise direction. Simultaneously turn the feed nut in a clockwise direction to establish a constant feed. Do not remove too much material at once; the cutting blades should make light, uninterrupted cuts.

NOTE

Before interrupting the cut, back the cutter blades away from the tubing. Use compressed air or a small brush to remove the accumulation of chips from the blades and the tubing throughout the coning operation.

- Continue the operation until the feed nut bottoms on the housing. Turn the cutter handle several more rotations to face-off the end of the cone.
- Retract the cutter blades, loosen the gland nut and remove the tubing. Inspect the cone for surface finish and completeness.

NOTE

Clean the machining chips from the blade and from the collet before coning the next tube.

Power Coning

- Secure the tubing in a tube vise. No more than the recommended length of tubing should extend beyond the face of the vice. See Table 2-10, Recommended Extension Length.
- Mount the coning tool in a 3/8-inch or 1/2-inch, variable speed power drill. Apply cutting oil to the end of the tube and slide the coning tool on the tubing.
- Apply steady pressure against the end of the tubing while the cone is being cut.

Apply cutting oil frequently and liberally throughout the cutting operation. A medium weight cutting oil with high sulfur content is recommended.

- The tool will stop cutting when the tube angle and facing is complete.

NOTE

Clean the machining chips from the blade and body of the tool before coning the next tube.

Table 2-10
Recommended Extension Length

1/4" Tubing	1.25-1.50" (31.8-38.1 mm)
3/8" Tubing	1.25-1.50" (31.8-38.1 mm)
9/16" Tubing	1.75-2.00" (44.5-50.8 mm)
3/4" Tubing	3.00-3.50" (76.2-88.9 mm)

Hand Threading

1. Secure the coned tubing in a tube vise. No more than the recommended length of tubing should extend beyond the face of the vice. See Table 2-10, Recommended Extension Length.
2. Apply cutting oil to the end of the tube and slide the threading tool on the tubing.
3. Grip the handles of the tool firmly, apply steady pressure and turn the tool counter-clockwise. Approximately every half turn, reverse direction to break off and remove the chips.

Apply cutting oil frequently and liberally throughout the cutting operation. A medium weight cutting oil with high sulfur content is recommended.

4. Continue threading until the proper thread length is reached, see Table 2-9, Column L. Remove the tool from the end of the tubing.

NOTE

Clean the machining chips from the die and body of the tool before threading the next tube.

Power Threading

1. Secure the coned tubing in a tube vise. No more than the recommended length of tubing should extend beyond the face of the vice. See Table 2-10, Recommended Extension Length.
2. Mount the threading tool in a 3/8-inch or 1/2-inch, variable speed power drill. Apply cutting oil to the end of the tube and slide the threading tool on the tubing.
3. Make sure the drill is set to turn counter-clockwise. Apply steady pressure against the end of the tubing while the threads are being cut.

Apply cutting oil frequently and liberally throughout the cutting operation. A medium weight cutting oil with high sulfur content is recommended.

4. Continue threading until the proper thread length is reached, see Table 2-9, Column L. Reverse the direction of the drill and remove the threading tool.

NOTE

Clean the machining chips from the die and body of the tool before threading the next tube.

2.8 High Pressure Connections

When installing high pressure discharge piping it is essential that all burrs are carefully removed and the tubing sections purged with clean compressed air prior to assembly. Lightly spraying the inside of the tube with a carrier fluid, such as WD-40, before purging with air will help carry the burrs.

High pressure piping must be installed without torsional or bending stresses and proper supports and guides must be provided. Torsional stress will cause premature component failure.

Pure Goop anti-seize compound must be applied to the threads and contact surfaces of all stainless steel components prior to assembly. Failure to lubricate components with Pure Goop will result in galling, rendering the components useless.



Do not use any other anti-seize compound. Apply Pure Goop **only to stainless steel** components.

Standard Connections

Standard connections are used for general applications where internal pressure is the only load on the tubing.

Figure 2-8: Standard High Pressure Connections

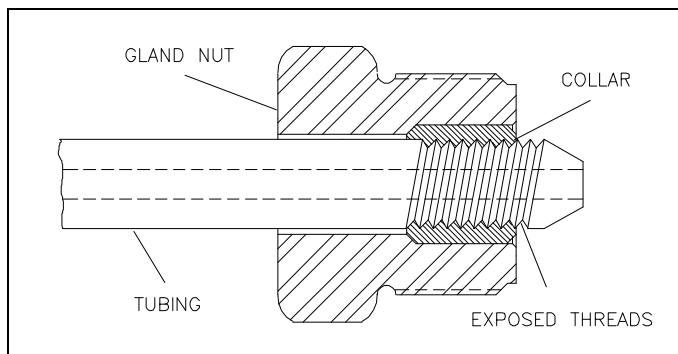

1. Deburr the tubing ID and thoroughly clean the tubing threads.
2. Slip the gland nut onto the tubing.
3. Apply Pure Goop to the threads on the tubing. Screw the collar onto the threaded end of the tubing leaving 1-1/2 to 2-1/2 threads exposed on the tubing between the collar and the coned tubing.
4. Apply Pure Goop to the male threads on the gland nut and insert the tubing into the connection. Engage the gland nut and tighten finger tight.

5. Tighten the gland nut to the torque specifications in Table 2-11.



Proper piping supports and guides must be provided. End connections will not support the tubing load alone.

Table 2-11
Torque Specifications
High Pressure Connections

1/4" Tubing	25 ft-lb (34 Nm)
3/8" Tubing	50 ft-lb (68 Nm)
9/16" Tubing	110 ft-lb (149 Nm)
3/4" Tubing	120 ft-lb (163 Nm)

Anti-Vibration Connections

The bending stresses resulting from excessive vibration or shock on the threaded area of the tubing can cause premature failure at the back of the thread. When tubing will be subjected to vibration, rotation and movement, anti-vibration connections must be used. The anti-vibration collet gland transfers the stress to the unthreaded section of the tubing, and the gripping action of the collet strengthens the entire assembly.

Figure 2-9: Anti-Vibration Connections

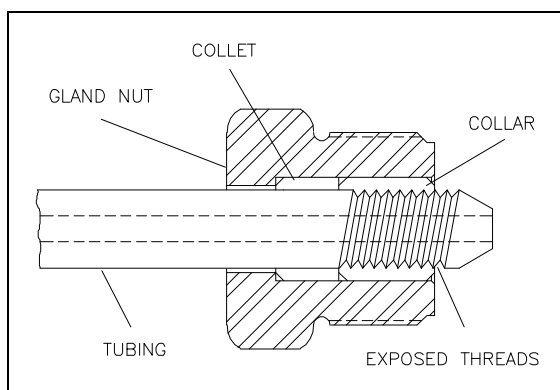

1. Deburr the tubing ID and thoroughly clean the tubing threads.
2. Slip the gland nut and the collet onto the tubing.

3. Apply Pure Goop to the threads on the tubing. Screw the collar onto the threaded end of the tubing leaving 1-1/2 to 2-1/2 threads exposed on the tubing between the collar and the coned tubing.
4. Apply Pure Goop to the male threads on the gland nut and insert the tubing into the connection. Engage the gland nut and tighten finger tight.
5. Tighten the gland nut to the torque specifications in Table 2-11.

When a flexible whip is used to allow cutting nozzle movement, anti-vibration fittings and proper supports and guides must be provided to prevent failures from non-water related stresses. The whip will only flex in a single plane without being subjected to torsional stress. The use of high pressure swivels is strongly recommended.

2.9 Commissioning

When the machine has been positioned, all service connections installed, and the high pressure plumbing has been installed to the cutting area, the machine is ready to be commissioned.

The following procedure is used for the initial startup and testing of the machine.

1. Fill the hydraulic oil reservoir following the procedure, Hydraulic Oil Maintenance, Section 6, Recirculation System.
2. Check all areas in and around the pump for foreign objects and debris. Remove all tools, parts, etc. from the area.
3. Open the shutoff valves on the service connections and check for leaks.
4. Check the connection between the main power disconnect and the disconnect/circuit break on the enclosure door. Verify the proper voltage supply. Close the enclosure door and turn the control power on.

NOTE

The following steps in the commissioning process require a thorough understanding of the controls and the overall operation of the pump.

It is strongly recommended that all personnel involved in this process carefully review Section 4, Operations, before proceeding.

5. To activate the control panel display, pull the EMERGENCY STOP button out and press the RESET button. The control panel will go through a series of diagnostics, and the Run Screen will display. Refer to Section 4, Operation, for additional information regarding control panel functions.



- On the Run Screen, press the SET PRESSURE button to display the keyboard. Set the operating pressure to 20,000 psi (1,379 bar).

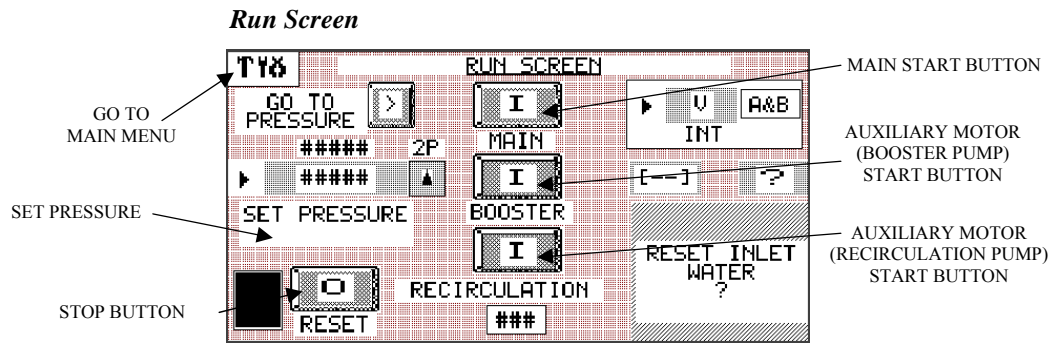

- From the Main Menu, select the Configuration Screen, a password protected screen. If necessary, contact KMT Waterjet for assistance.

Press the ▲ or ▼ arrow to set the PRESSURE OFFSET to 20.

Configuration Screen

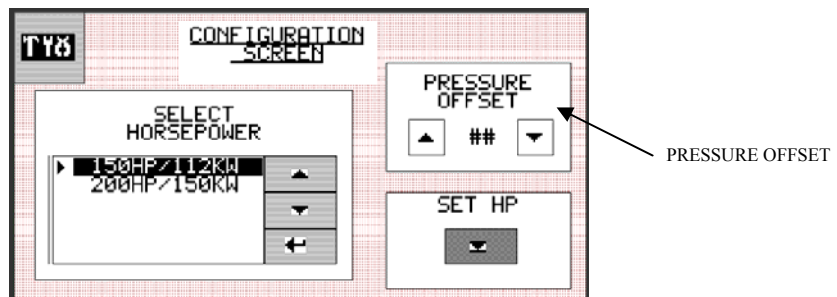

NOTE

The existing pressure offset value was determined by operating conditions during factory testing. Reset the valve to 20 before proceeding.

- Return to the Run Screen and press the INT button to display the Valve Position Screen. Press the INT button to select intensifiers A and B. The Valve Position Screen will display the correct position for the low pressure and high pressure water valves for the selected intensifier configuration. On the Redundant Valve Position Screen, the correct position for the 3-way hydraulic valve on each hydraulic pump will also display.

Valve Position Screen

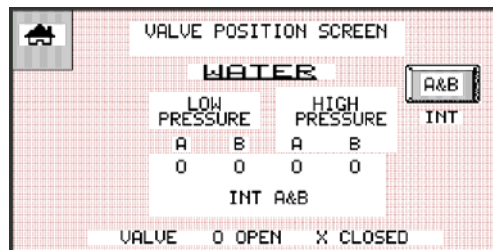

Redundant Valve Position Screen

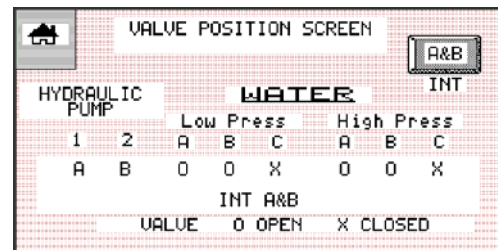

- Open or close the low and high pressure water valves to correspond to the correct positions for the selected intensifier configuration.

On redundant models, position the hydraulic valves to correspond to the selected configuration.

- Check the rotation of the auxiliary motor for the booster pump. On the Run Screen, press the BOOSTER START button to start the auxiliary motor and booster pump. Observe the Booster Pressure Gauge on the gauge display on the front of the machine. If the motor rotation is correct, pressure will begin to build immediately. If the rotation is not correct, the gauge will not move.

If the motor shaft is rotating in the wrong direction, press the STOP button and turn the control power off by pressing the EMERGENCY STOP button.

The electrical power phase for the booster pump motor must be reversed to any two motor leads. The leads can be reversed at the auxiliary motor contactor or at the auxiliary motor.



Do not allow the motor to run backward. Incorrect motor rotation will result in damage to the booster pump.

- Check the rotation of the auxiliary motor for the recirculation pump. On the Run Screen, press the RECIRC START button to start the auxiliary motor and recirculation pump.

Observe the gauge on the hydraulic filter head. If the motor rotation is correct, pressure will begin to build immediately. If the rotation is not correct, the gauge will not move.

If the motor shaft is rotating in the wrong direction, press the STOP button and turn the control power off by pressing the EMERGENCY STOP button.

The electrical power phase for the recirculation pump motor must be reversed to any two motor leads. The leads can be reversed at the auxiliary motor contactor or at the auxiliary motor.



Do not allow the motor to run backward. Incorrect motor rotation will result in damage to the booster pump.

12. Press the BOOSTER START button to start the booster pump and observe the Booster Pressure Gauge to ensure the boosted water pressure is between 90-120 psi (6-8 bar). If not, the system relief valve on the low pressure manifold must be adjusted. Adjust the valve following the procedure, Relief Valve Adjustment, Section 5, Low Pressure Water System.
13. Check the rotation of the main motor. Press the MAIN START button on the Run Screen. The auxiliary motors will start and 10 seconds later, the main motor will start. Observe the hydraulic pressure gauges on the gauge display. If the motor rotation is correct, pressure will begin to build in just a few seconds. If the rotation is not correct, the gauge will not move.



Do not allow the motor to run backward. Incorrect motor rotation will result in damage to the hydraulic pumps.

If the motor shaft is rotating in the wrong direction, press the STOP button and turn the control power off by pressing the EMERGENCY STOP button.

The electrical power phase for the main motor must be reversed to any two motor leads. The leads must be reversed at the disconnect/circuit breaker on the enclosure door, or at the main power disconnect, not at the motor or motor starter.



If the main motor rotation requires correction, the rotation of the auxiliary motor must also be changed.

14. Remove the cutting orifice and open the nozzle valve.
15. Activate the control power and press the MAIN START button to start the main motor. The dump valve will open for a short time to allow trapped air to bleed from the high pressure cylinders. The auxiliary motors will start the recirculation and booster pumps. Run the machine in low pressure mode for approximately five minutes with the orifice removed to purge the system.
16. Check for any leaks in the plumbing, or around the high pressure cylinders. If leaks are detected, stop the machine and correct any problems.
17. Check the safety circuits by pushing the EMERGENCY STOP button in and verifying that the power goes off and high pressure water is drained from the system. If applicable, check all remote start and emergency stop functions.
18. Install a large, inexpensive orifice and start the machine.
19. On the Run Screen, select high pressure operation. Increase the pressure setting in 10,000 psi (689 bar) increments, checking for leaks at each interval. Continue increasing the pressure until the desired operating pressure is reached.

As the pressure is increased, the pressure offset value on the Configuration Screen may require adjustment. The pressure offset function prevents the operating pressure from overshooting the set pressure at startup and can be set from a minimum value of 5, to a maximum value of 20. The amount of overshoot depends on the specific operating conditions: the amount of system plumbing, number of cutting heads, and the application.

20. If the unit is a redundant model, reduce the pressure setting to 20,000 psi (1,379 bar) and change the intensifier configuration to A and C or B and C. Repeat steps 13-18 to commission and test intensifier C.

NOTE

It is strongly recommended that the high pressure plumbing be purged under high pressure operating conditions, using a large, inexpensive orifice. Contamination can be released when the tubing expands under pressure. Early orifice failures could be experienced if the piping is not adequately purged

2.10 Decommissioning

All local regulations must be adhered to when the machine is decommissioned and taken out of service for any reason.



SECTION 3

MAINTENANCE

3.1 Overview

The SL-V 150 and 200 have been designed to fail safely. Systems fail gradually; seals and connections begin to leak slowly or suddenly through specially designed weep holes. Water or oil dripping from a weep hole indicates internal seals or valves are beginning to fail, a warning that maintenance will be required.

The comprehensive fault detection and troubleshooting logic built into the programmable logic controller (PLC) monitors crucial pressure, temperature and fluid levels. Warning and shutdown sensors guard against potential injury and equipment damage.

3.2 Maintenance

The waterjet system has been designed for ease of maintenance and long, reliable operation. In order to keep the equipment in optimum operating condition, routine and preventive maintenance is essential. Detailed maintenance and troubleshooting procedures for specific systems are provided in subsequent sections of this manual.

Daily Inspection

The following inspection procedures should be performed each day. If problems are detected, they should be remedied before placing the machine in service.

- Prior to startup, inspect the area around the machine, the high pressure piping and connections for indications of leaks.
 - Make sure there is no maintenance work in process.
 - Check the hydraulic oil level.
- As the machine is started and water pressure increases, listen for unusual sounds.
 - Check for water or oil leakage.
 - Check the condition of the water filters and the oil filter.

Periodic Maintenance

A number of factors can contribute to component failure; poor water quality, operating conditions, or improper maintenance procedures. Maintaining a service log can be a useful method of tracking component life and maintenance trends. Analyzing service intervals will assist in preparing a preventive maintenance schedule tailored to your specific application and production requirements. Periodic maintenance, at regularly scheduled intervals, will minimize unscheduled downtime and premature component failure.

Improper assembly can lead to the premature failure of components. Maintenance procedures must be followed carefully; components must be properly cleaned prior to assembly and tightened to the correct torque specifications.

- Maintain a clean, dust and dirt free work area for maintenance.
- Use only clean, dry air and clean, filtered solvent when flushing parts.
- Use lint free cloths for cleaning.
- Use extreme care when aligning close tolerance parts for assembly. Do not force the parts together. If parts bind during assembly, they must be disassembled and re-aligned.
- Use only original KMT Waterjet replacement parts for consistent performance and reliability; and to protect equipment warranty.

To avoid unsafe conditions and the risk of equipment damage, operating personnel and service technicians must carefully read and follow the procedures in this manual.

High Pressure System Maintenance

The high pressure system is conveniently mounted on the front of the front of the machine. All service components are readily accessible, and can be removed from the unit easily for maintenance and service.

- High pressure fittings, valves and tubing must be rated for 60,000 psi (4,137 bar). Failure to use properly rated components may result in component failure, equipment damage and personal injury.
- Do not over-torque fittings to stop leakage.
- Ensure all components are clean, free of burrs, metal particles, dirt and dust prior to assembly.

After servicing high pressure components the high pressure water system must be thoroughly flushed to remove any debris or contaminants.

1. Operate the intensifier for a short period with the nozzle valve open and the orifice removed.
2. Turn the intensifier off and install an orifice.



3. Turn the machine on and increase the operating pressure in gradual increments. Check all high pressure connections for leaks.

Many components are lubricated prior to assembly. Table 3-1 lists the recommended lubricants and their applications. Substitutions are not recommended.

**Table 3-1
Lubrication Specifications**

Description	Application	Part Number
Pure Goop, 1 ounce	Stainless steel threads	10084440
FML-2 Grease, 14-1/2 ounce	O-rings, backup rings, bearing rings, seal components	10087385
JL-M Grease, 16 ounce	Non-stainless steel threads	49832199

3.3 Maintenance Precautions

Make sure all safety devices are operational. Each device should be checked on a specified schedule. If the device does not function, it must be replaced before operating the machine.

Check the EMERGENCY STOP button. The normal operating position is pulled out. Turn the power on and activate the emergency stop button by pushing it in to verify the power goes off and the safety dump valve opens to bleed the high pressure from the system.

Before performing any maintenance on the equipment, take the system out of service and make sure the controls are properly locked and marked. Never perform any maintenance on the equipment without making sure the main control power is locked out in the OFF position.

- **Never** service or maintain the equipment while it is operating.
- Steam or fog inside the top cover is an indication of a high pressure leak. All high pressure leaks must be repaired immediately. Press the EMERGENCY STOP button to turn the control power off and bleed off the high pressure water from the intensifier **before** lifting the cover.
- Never service or maintain any high pressure component, or loosen any high pressure fitting when it is pressurized. Press the EMERGENCY STOP button to turn the control power off and bleed off the high pressure water from the intensifier before servicing.
- If leakage occurs at a sealing surface, high pressure water is released through weep holes. If a pressurized fitting is loosened, a jet of high pressure water will exit the nearest weep hole with **possible hazardous results**.



3.4 Tool Kit

Table 3-2 provides a list of the spare parts and maintenance tools included in standard tool kit for SL-V 150 and 200 pumps. Components can also be ordered individually.

Table 3-2
Tool Kit
80075930

Part Number	Description	Quantity
10087385	FM-L Grease, 14-1/2 ounce	1
80078330	Seal Removal Tool Stand	1
10079986	Strap Wrench	1
10081370	Spanner Wrench	1
05053871	Combination Wrench, Box/Open	1
10084440	Pure Goop, 1 ounce	3
10087609	Crescent Wrench	1
20484961	Vee Block	1
05066139	Cylinder Wrench	1
05146618	HP Seal Installation Tool	1
10149029	Emery Cloth, 320 Grit	2
10149037	Emory Cloth, 400 Grit	6
10149045	Emory Cloth, 600 Grit	6
10149052	Glass Pane	1
20477469	Plunger Removal Tool	1
80078256	Torque Wrench, 5-75 Ft/Lbs	1
20470475	Seal Installation Tool Kit, Pneumatic Valve	1
10078772	HP Plug, .56	1
10078608	HP Gland, .56	1
80082191	JL-M Grease, 15 milliliter pack	2
80079239	End Cap Wrench	1
80078249	Socket Wrench, .38	1
20487868	Threadlocker 242 Adhesive, .50 milliliter tube	1
20494983	Threadlocker Primer, 1-3/4 ounce	1
20473684	Hex Socket, .63	1



SECTION 4 OPERATION

4.1 Overview

The SL-V 150 and 200 utilize a programmable logic controller (PLC) to provide comprehensive fault detection and troubleshooting logic. The operator interface is through a touch sensitive control display where operating parameters are set and monitored. The operator functions and warnings offer a comprehensive view of operating conditions, impending faults, shutdown faults and suggested remedies.

Figure 4-1 identifies the control panel components and functions.

Figure 4-1: Control Panel

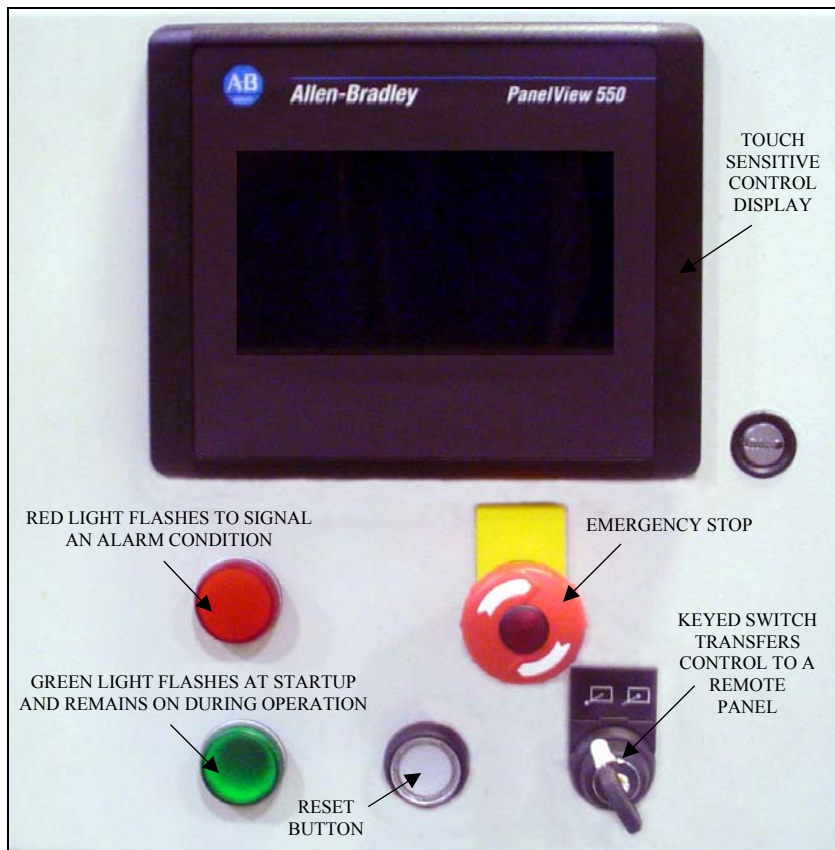

Startup Sequence

After a normal motor stop, the safety dump valve will be closed and high pressure will be present in the system. Press the MAIN START button on the Run Screen. The auxiliary motors will start the recirculation and booster pumps. After a 10 second delay, the main motor will start.



After an emergency stop, the safety dump valve will be open and high pressure released in the system. The dump valve will close three seconds after the intensifiers begin to stroke.

Pull the EMERGENCY STOP button out and push the RESET button to activate the control display. Press the MAIN START button on the Run Screen. The auxiliary motors will start the recirculation and booster pumps. After a 10 second delay, the main motor will start.

4.2 Partial Power Operation

The SL-V 150 and 200 are designed with the ability to operate with a single intensifier. Partial power operation allows operation to continue if one intensifier requires maintenance. It also serves as a troubleshooting tool in determining which intensifier is the source of a problem.

Partial power operation reduces the overall capacity of the machine as illustrated in Table 4-1.



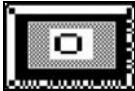



**Table 4-1
Partial Power Operation**

	150HP	200HP
Horsepower capacity	100 HP (75 Kw)	100 HP (75 Kw)
Overstroke set point, maximum limit at 55,000 psi (3,792 bar)	79	79
Overstroke set point, maximum limit at 60,000 psi (4,137 bar)	75	75
Maximum flow rate (at full pressure)	1.88 gpm (7.21 L/min)	1.88 gpm (7.21 L/min)
Maximum single orifice diameter (at full pressure)	0.019 inch (0.483 mm)	0.019 inch (0.483 mm)

4.3 Display Controls

Table 4-2 illustrates controls common to all displays.

Table 4-2
Display Controls

Control	Function	Comments
	<p>START</p> <p>The START buttons only display on the Run and Maintenance Screens</p>	<p>There are three START buttons on the Run Screen. The MAIN START button starts the main motor and the auxiliary motors.</p>
		<p>The BOOSTER START button starts the auxiliary motor that drives the booster pump. The RECIRC START button starts the auxiliary motor that drives the recirculation pump.</p>
		<p>When started from the Maintenance Screen, the machine will start in maintenance mode. The machine must be started from the Maintenance Screen to access the maintenance functions.</p>
	<p>STOP</p> <p>The STOP button displays on all screens except the Configuration, Valve Position, Alarm History and Language Screens</p>	<p>Motor stop only, the control power remains on.</p>
	<p>Return to Main Menu</p>	
	<p>Return to Run Screen</p>	
	<p>ON position for controls on the Setup Screen</p>	<p>Enables function</p>
	<p>OFF position for controls on the Setup Screen</p>	<p>Disables function</p>

4.4 Main Menu

The Main Menu provides a list of available setup and monitoring screens. Press the ▲ or ▼ arrow to highlight the desired screen. Press ENTER (↵) to display the selected screen.

Figure 4-2: Main Menu

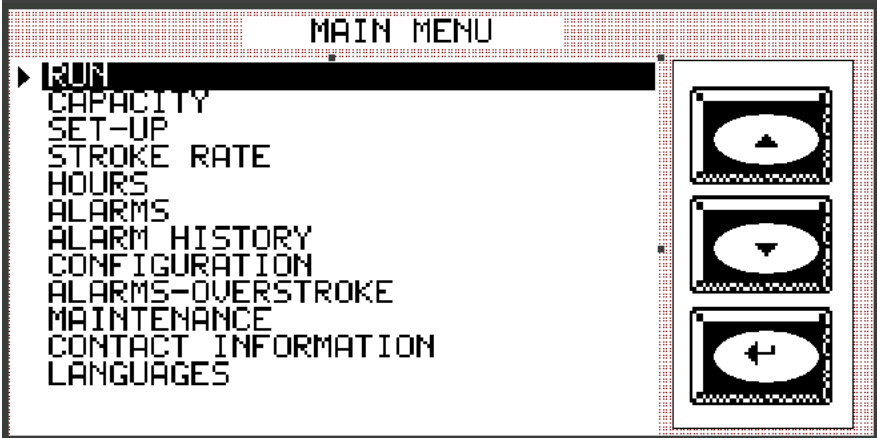

4.5 Run Screen

The Run Screen is the only location where the machine can be started to create pressure. On power-up, the display will default to the Run Screen. After five minutes on any other screen, the display will return to the Run Screen.

If the machine is connected to a header system that is controlled by the KMT Waterjet Balancing System, a number displays in the bottom corner of the Run Screen to indicate the machine's position.

Figure 4-3: Run Screen

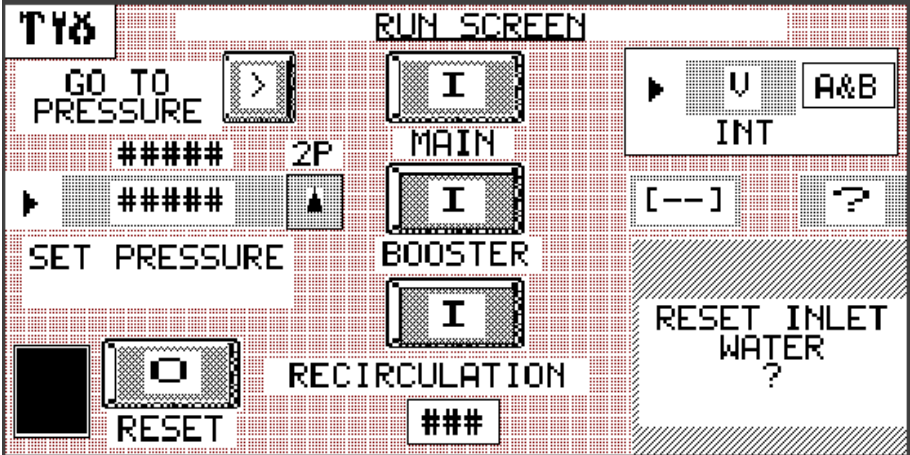

The Run Screen displays the following functions:

MAIN	<p>The MAIN button starts the main motor and the auxiliary motor.</p> <p>The MAIN START button flashes when the machine is ready to start. After the machine has been stopped, there is a five second delay before the machine can be restarted.</p>
BOOSTER	<p>The BOOSTER button starts the auxiliary motor for the booster pump. Pressing the STOP button manually stops the booster pump.</p>
RECIRC	<p>The RECIRC button starts the auxiliary motor for the recirculation pump. The machine will recirculate for 10 minutes before automatically shutting off. Recirculation time displays next to the button. Pressing the STOP button manually stops the recirculation pump.</p>
STOP	<p>The STOP button flashes to indicate the machine is on and can be stopped by pressing this button.</p>
RESET	<p>The inlet water solenoid indicator. The inlet water solenoid valve is automatically closed five minutes after the machine shuts down. When RESET flashes, press the STOP button to reset and open the valve. This function can be disabled on the Setup Screen.</p>
INT	<p>Press the INT button to display the Valve Position Screen and select the desired intensifier configuration.</p>
SET PRESSURE	<p>Press the SET PRESSURE button to display the keyboard in Figure 4-4 and set the desired operating pressure. The pressure will slowly adjust until it reaches the set pressure. The actual operating pressure displays above the button.</p> <p>Operating pressure is displayed in either psi or bar and the option is selected on the Language Screen.</p>
GO TO PRESSURE	<p>Press the ➤ arrow to rapidly attain the set pressure.</p>
2P (DUAL PRESSURE)	<p>In local mode, press the ▲ or ▼ arrow to select high or low pressure. When stopped and restarted the machine will always start in low pressure. After 5-60 seconds, depending on the interval selected by the operator, it will go to high pressure or remain in low pressure, depending on the previous setting.</p> <p>In remote mode, a customer installed switch will toggle between the high and low setting.</p>
ALARM	<p>When a fault is detected the alarm indicator flashes and displays the last alarm sensed by the machine.</p> <p>Press the [■ ■] button to display the overstroke alarm screen.</p> <p>Press the ? button to display the general alarm screen.</p>

Figure 4-4: Keyboard

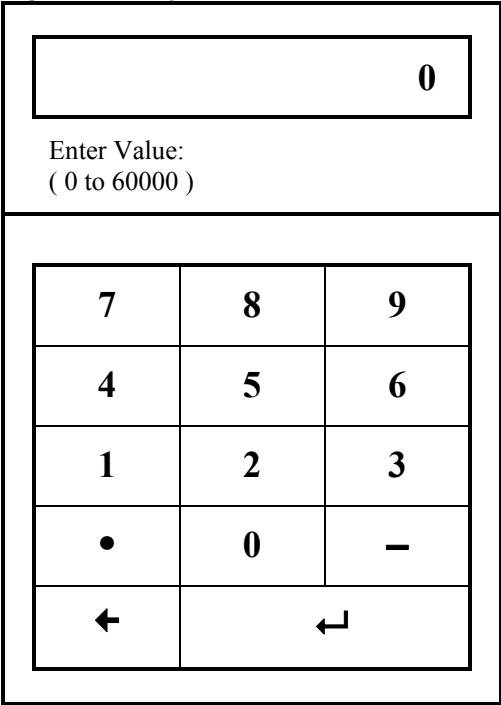

4.6 Valve Position Screen

The active intensifier(s) are selected on the Valve Position Screen. Press the INT button to select the desired configuration. The Valve Position Screen displays the correct position for the low pressure and high pressure water valves for the selected intensifier configuration. For example, when operating both intensifiers A and B, low pressure valves A and B are open and high pressure valves A and B are open. When operating intensifier A only, the low and high pressure valves for intensifier B are closed.

Figure 4-5: Valve Position Screen

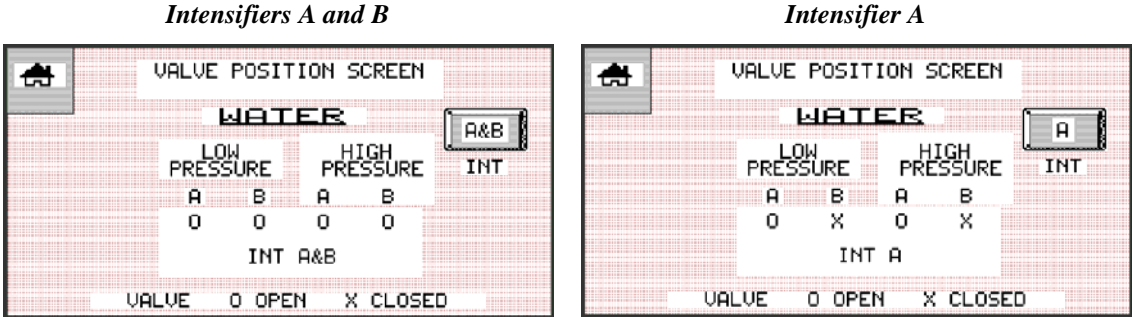

The Valve Position Screen in Figure 4-6 will display if the machine is a redundant model and intensifiers A and C are selected. In addition to the low and high pressure water valve positions, the Redundant Valve Position Screen displays the correct position for the 3-way hydraulic valves on the hydraulic pumps.

The 3-way hydraulic valves direct the oil flow from the hydraulic pumps to the intensifiers. Hydraulic pump 1 is closest to the motor and supplies hydraulic oil to intensifier A or C. Hydraulic pump 2 supplies intensifier B or C.

Figure 4-6: Redundant Valve Position Screen

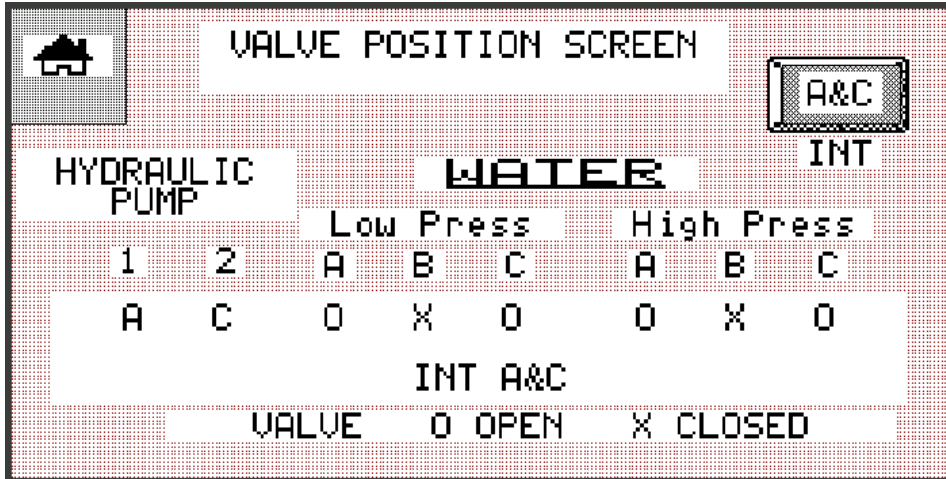

4.7 Setup Screen

Functions and options can be enabled or disabled on the Setup Screen.

Figure 4-7: Setup Screen

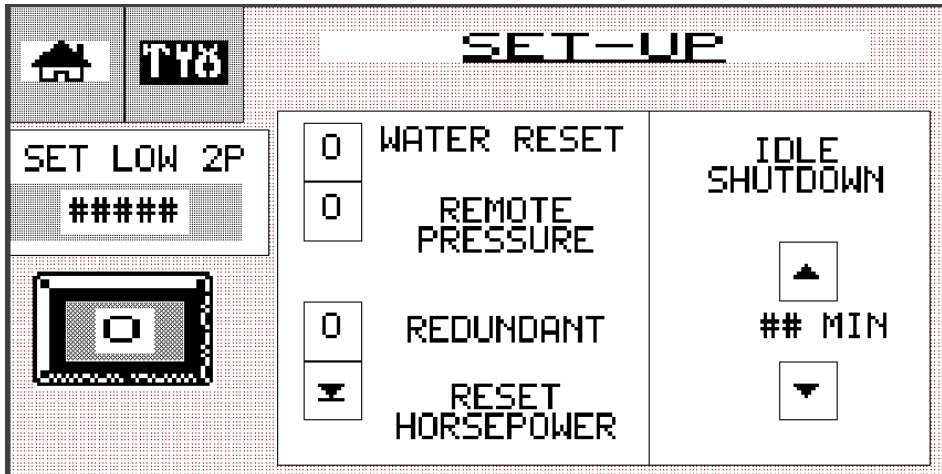

The Setup Screen displays the following functions:

- WATER RESET FUNCTION** Automatically shuts the inlet water solenoid valve off five minutes after the machine shuts down; press the control to turn the function ON or OFF.

REMOTE PRESSURE	REMOTE PRESSURE allows the output pressure to be set from a remote 0-10V signal; press the control to turn it ON for remote pressure input or OFF to enable default local control features.
REDUNDANT	Press the control to turn it ON for redundant or OFF for non-redundant models.
RESET HORSEPOWER	RESET HP is only pressed when a new version of the display or PLC program is installed. The control will reset the horsepower.
SET LOW 2P (DUAL PRESSURE)	Press the SET LOW 2P numeric field to display the keyboard in Figure 4-4 and set the low operating pressure. If the field is blank, the setting defaults to zero and sets the pump at the lowest compensator setting.
IDLE SHUTDOWN	Automatically stops the main motor after a deadhead condition occurs; press the ▲ or ▼ arrow to select an idle time from 5-60 minutes

4.8 Configuration Screen

The Configuration Screen is password protected and used to set the horsepower during factory testing, and the pressure offset during initial commissioning. The password is 111320 and should only be given to personnel with the authority to change the pressure offset. The setting will not require adjustment unless operating conditions change significantly.

Figure 4-8: Configuration Screen

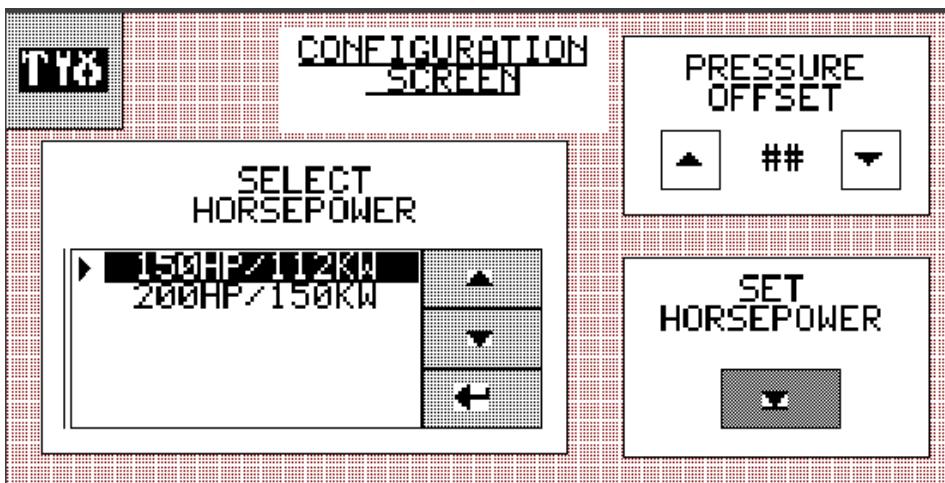

PRESSURE OFFSET

The pressure offset function prevents the operating pressure from overshooting the set pressure at startup. Press the ▲ or ▼ arrow to set the pressure offset from a minimum value of 5 to a maximum value of 20.

The amount of overshoot depends on the specific operating conditions: the amount of system plumbing, number of cutting heads, and the application.

4.9 Stroke Rate Screen

The Stroke Rate Screen displays the real time strokes per minute. The Stroke Rate Screen in Figure 4-9 displays on standard models. The screen in Figure 4-10 displays on redundant models. Both screens display the following functions.

Figure 4-9: Stroke Rate Screen

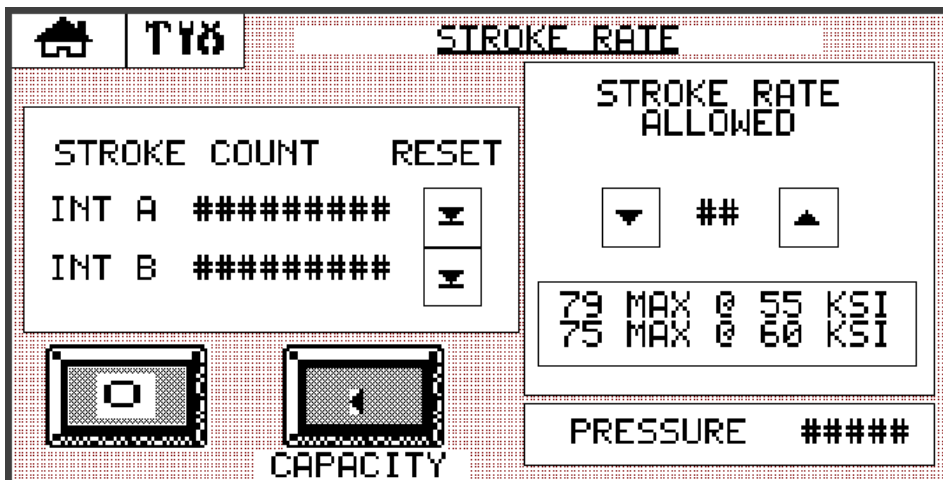

STROKE RATE ALLOWED

Increases or decreases the allowed stroke rate; press the ▲ or ▼ arrow to select the overstroke set point. Stroke rate should be set 4 to 5 strokes higher than the desired operating rate to shutdown the machine quickly in the event of an overstroke condition.

STROKE COUNT

Displays the total number of strokes for each intensifier since the counter was reset. Press the ▼ button to reset the stroke counter for one or more intensifiers.

CAPACITY

Press the CAPACITY button to display the Capacity Screen.

PRESSURE

Displays the current operating pressure.

Figure 4-10: Redundant Stroke Rate Screen

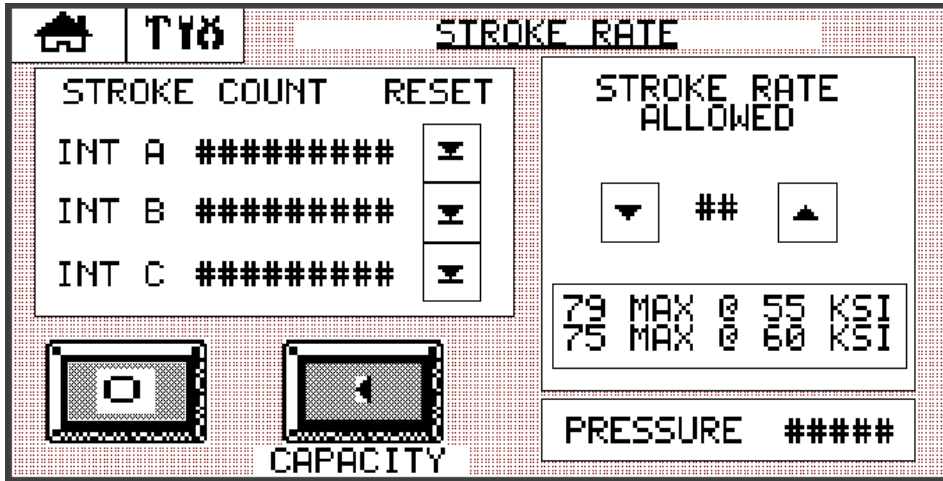

The upper limit points displayed on the Stroke Rate Screen are preset. Table 4-3, Overstroke Set Points, illustrates the upper limits. It also shows the number of strokes per minute above the setting that will result in a warning or shutdown condition.

Before setting the allowed stroke rate, monitor the actual stroke rate during normal operation. The stroke rate allowed should then be set 4 to 5 strokes per minute above that rate.

Table 4-3
Overstroke Set Points

Horsepower	Maximum Limit		Strokes Per Minute Added to Stroke Rate Allowed	
	55,000 psi	60,000 psi	Warning	Shutdown
150-200	79	75	3	6

Example

The allowable stroke rate is set at 40 strokes per minute. If the stroke rate reaches 43, an overstroke warning will be issued 15 seconds after detection. The warning will continue until the rate returns to normal, or exceeds the overstroke shutdown point.

If the stroke rate reaches 46 an overstroke shutdown pending will be issued. If the condition persists for 30 seconds, an automatic shutdown will occur.

4.10 Capacity Screen

The Capacity Screen displays the actual stroke rate, signal to each proportional valve, the percent of full load for each intensifier and the current operating pressure.

The internal balancing system controls the proportional pressure valves and the strokerate. Pressure is maintained at an accuracy of +2,000 psi (+138 bar) to -500 psi (-34 bar). The pressure transducer continually monitors the total system pressure. If the system pressure varies outside this accuracy range, the balancing system automatically adjusts the signal to the proportional valves, increasing or decreasing the demand from each hydraulic pump.

Figure 4-11: Capacity Screen

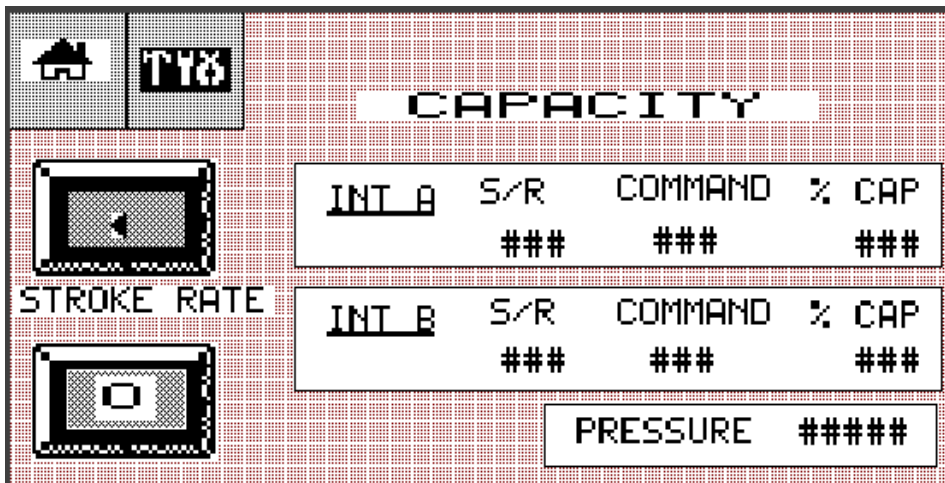

S/R	Displays the actual strokerate for each intensifier. The total number of strokes for all intensifiers represents the total load at any given time.
COMMAND	Displays the signal to the proportional pressure valves on each hydraulic pump as a percent. For example, if the set pressure is 30,000 psi (2,068 bar), a signal is sent to each valve to open 50%.
% CAP	Displays the percent of the full load strokes for each intensifier.
PRESSURE	Displays the actual operating pressure, the input signal from the pressure transducer.
STROKE RATE	Press the STROKE RATE button to display the Stroke Rate Screen

Figure 4-12: Redundant Capacity Screen

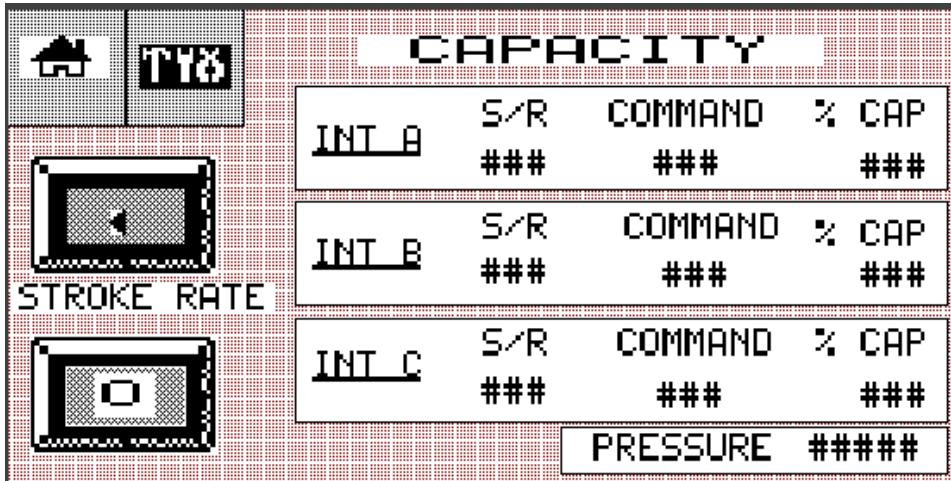

4.11 Hours Screens

The Hours Screen displays total operating hours for each intensifier, the maintenance hours for each intensifier and the total operating hours for the main motor. Operating hours cannot be reset. Maintenance hours can be reset by pressing the INT A or INT B button. The Hours Screen in Figure 4-14 displays when the machine is a redundant model.

Figure 4-13: Hours Screen

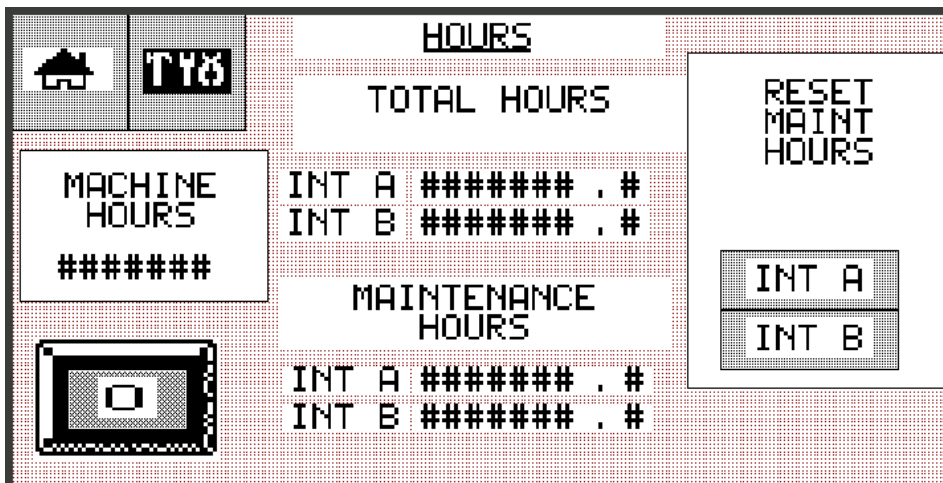
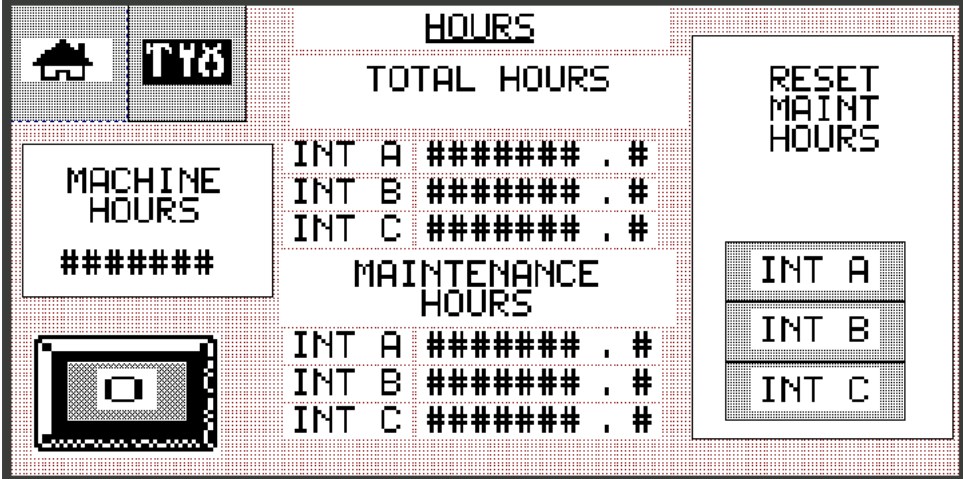

Figure 4-14: Redundant Hours Screen



4.12 Run Screen Alarms

In an alarm state, the *last* alarm sensed by the machine is displayed on the Run Screen. If multiple alarm conditions have occurred they can be viewed on one of the two Alarm Screens. Run Screen alarms are listed in Table 4-4.

Figure 4-15: Run Screen Alarms

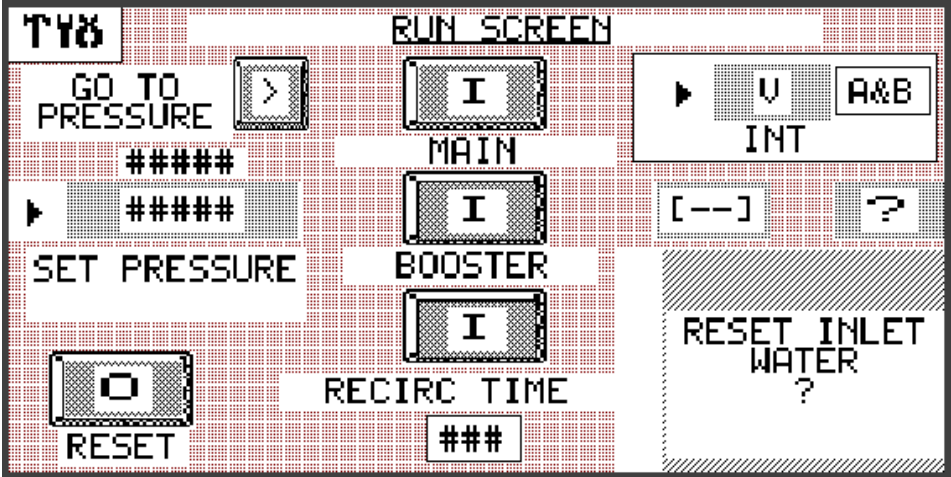

Table 4-4
Run Screen Alarms

Alarm	Indication	Comments
Bleed High Pressure Lines	Indicates high pressure is present in the lines when the machine stops.	Intensifier is shut down; high pressure is present in the discharge plumbing and should be bled off to avoid possible injury.
Booster Temperature High	Booster pump water temperature is high, in excess of 128° F (53° C).	Shutdown will occur if condition persists.
Discharge Pressure Out of Range	Actual operating pressure is 2,000 psi (138 bar) above or 500 psi (34 bar) below the set point.	An alarm is issued if the pressure remains out of range for five minutes. An out of range alarm does not result in shutdown.
High Oil Temperature Warning	High hydraulic oil temperature, in excess of 131° F (55° C).	
High Oil Temperature	High hydraulic oil temperature, in excess of 150° F (65° C).	Shutdown will occur if condition persists.
High Pressure Warning	Output pressure is above 64,000 psi (4,413 bar).	
PLC Low Battery	Battery in the PLC is low. After the alarm occurs, the battery will last for approximately seven days.	Replace with backup/replacement battery.
Low Booster Pressure	Booster pump output pressure is inadequate for proper machine operation, less than 60 psi (4 bar). Shutdown is pending.	Seven seconds after the machine is started, the booster pump output pressure switch is monitored. If the switch opens, a warning is issued. If the condition persists, shutdown will occur after 30 seconds.
Low Inlet Water Pressure	Cutting supply water pressure is inadequate to permit proper machine operation, less than 30 psi (2 bar).	If the inlet cutting water pressure switch is not closed, the machine will not start and a warning is issued. If the switch opens after the machine is started a warning is issued. If the condition persists shutdown occurs after five continuous seconds.

Table 4-4
Run Screen Alarms

Alarm	Indication	Comments
Overstroke Warning		Overstroke warnings, pending shutdowns and shutdowns are issued as left, right or intensifier. An intensifier warning or shutdown indicates the intensifier is shifting too fast in both directions. If the machine is running near full capacity it is possible an intensifier shutdown is actually caused by a left or right fault. This can be diagnosed further by reducing the operating pressure and monitoring all alarm occurrences on the Stroke Rate Alarm Screen.
Overstroke Shutdown Pending	Abnormally high stroke rate caused by an external or internal leak.	Shutdown will occur if condition persists for 30 seconds.
Recirculation Pressure Low	Oil pressure to heat exchanger is low, 15 psi (1 bar).	Shutdown is pending.
Reset Inlet Water	Inlet water solenoid valve must be reset. RESET will flash and can be reset by pressing the STOP button.	

4.13 Alarm Banners

When a shutdown condition occurs an Alarm Banner will appear over the current screen. The banner displays the type of shutdown and lists possible remedies. Potential remedies are listed in order of most to least probable.

Figure 4-16: Alarm Banner





Pressing the RESET button will clear the alarm banner, but it will not clear the fault. The banner will continue to display until the fault is corrected. Shutdowns will appear on the Alarm History Screen. Alarm banner shutdowns are listed in Table 4-5.

**Table 4-5
Alarm Banner Shutdowns**

Alarm		Comments	Possible Remedies
1.	Softstart Fault		Check softstart display for error type. <i>Refer to Section 10, Troubleshooting, for details regarding softstart faults and remedies.</i>
2.	Motor Feedback Failure		Check motor starter output module.
3.	Oil Level Low		Check level gauge.
			Check for hydraulic leaks.
4.	Oil Temperature High	High hydraulic oil temperature, in excess of 150° F (65° C).	Check cooling water.
5.	Low Recirc Pressure	Oil pressure to heat exchanger is low, less than 15 psi (1 bar).	Check operating condition of recirculation pump.
6.	Low Booster Pressure	Booster pump output pressure is inadequate for proper machine operation, less than 60 psi (4 bar).	Check system relief valve adjustment.
			Check operating condition of booster pump.
7.	Low Inlet Water Pressure	Cutting supply water pressure is inadequate to permit proper machine operation, less than 30 psi (2 bar).	Check water supply.
			Check water filter.
8.	Long Idle Time Shutdown		
9.	Left Overstroke Shutdown Int A		Check companion intensifier for fault.
			Check left high pressure seal.
			Check right discharge check valve.
			Check left inlet check valve.
			Check the position of the low and high pressure water valves and the hydraulic valves.

Table 4-5
Alarm Banner Shutdowns

Alarm		Comments	Possible Remedies
10.	Right Overstroke Shutdown Int A		Check companion intensifier for fault.
			Check right high pressure seal.
			Check left discharge check valve.
			Check right inlet check valve.
			Check the position of the low and high pressure water valves and the hydraulic valves.
11.	T/W Overstroke Shutdown Int A		Check companion intensifier for fault.
			Check plumbing for leaks.
			Check high pressure orifice.
			Check overstroke setting.
			Check the position of the low and high pressure water valves and the hydraulic valves.
12.	T/W Overstroke Shutdown Int B		Check companion intensifier for fault.
			Check plumbing for leaks.
			Check high pressure orifice.
			Check overstroke setting.
			Check the position of the low and high pressure water valves and the hydraulic valves.
13.	T/W Overstroke Shutdown Int C		Check companion intensifier for fault.
			Check plumbing for leaks.
			Check high pressure orifice.
			Check overstroke setting.
			Check the position of the low and high pressure water valves and the hydraulic valves.

Table 4-5
Alarm Banner Shutdowns

Alarm		Comments	Possible Remedies
14.	Left Overstroke Shutdown Int B		Check companion intensifier for fault.
			Check left high pressure seal.
			Check right discharge check valve.
			Check left inlet check valve.
			Check the position of the low and high pressure water valves and the hydraulic valves.
15.	Left Overstroke Shutdown Int C		Check companion intensifier for fault.
			Check left high pressure seal.
			Check right discharge check valve.
			Check left inlet check valve.
			Check the position of the low and high pressure water valves and the hydraulic valves.
16.	Right Overstroke Shutdown Int B		Check companion intensifier for fault.
			Check right high pressure seal.
			Check left discharge check valve.
			Check right inlet check valve.
			Check the position of the low and high pressure water valves and the hydraulic valves.
17.	Right Overstroke Shutdown Int C		Check companion intensifier for fault.
			Check right high pressure seal.
			Check left discharge check valve.
			Check right inlet check valve.
			Check the position of the low and high pressure water valves and the hydraulic valves.

Table 4-5
Alarm Banner Shutdowns

Alarm		Comments	Possible Remedies
18.	Alarm! Pressure Transducer Error	Error must be corrected before normal operation can resume.	Check wiring connection.
19.	Booster Temp High	Booster pump water temperature is high, in excess of 128° F (53° C).	Check incoming water temperature.
			Check for long idle times.

4.14 General Alarm Screen

Multiple alarms can be viewed on the General Alarm Screen. If an alarm condition occurs the appropriate warning or pending message will display and flash. Table 4-6 describes these alarm conditions.

Figure 4-17: General Alarm Screen

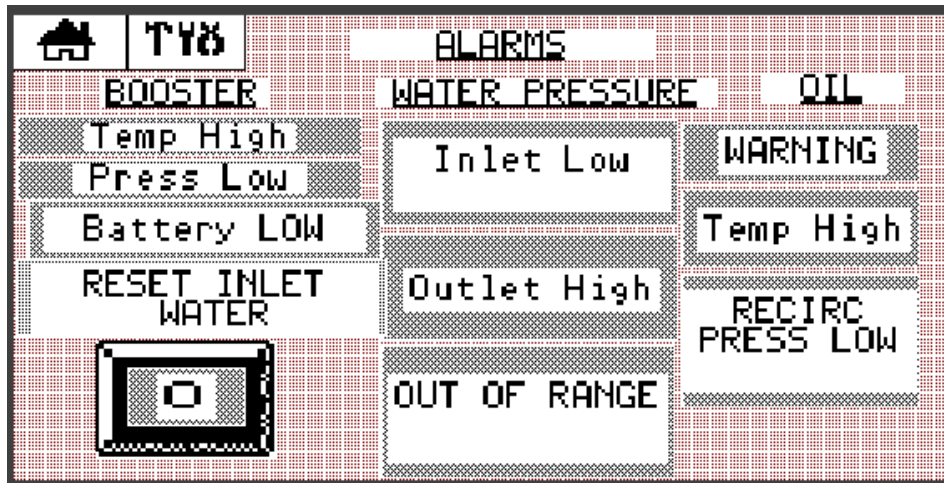

Table 4-6
General Alarm Screen

Alarm		Indication	Result
Battery Low		Battery is low and needs to be replaced	The battery will last approximately seven days after the alarm occurs.
Booster	Temp High	High booster water temperature, in excess of 128° F (53° C)	Shutdown will occur if the condition persists for 30 continuous seconds.
	Press Low	Low water pressure from booster pump, less than 60 psi (4 bar)	Shutdown will occur if the condition persists for 5 continuous seconds.
Water Pressure	Inlet Low	Low inlet water pressure, less than 30 psi (2 bar)	Shutdown will occur if condition persists for 5 continuous seconds.
	Outlet High	Excessively high outlet water pressure, in excess of 64,000 psi (4,413 bar)	Does not result in a shutdown.
	Out of Range	Actual operating pressure is 2,000 psi (138 bar) above or 500 psi (34 bar) below the set point.	Does not result in a shutdown.
Oil	Warning	Oil temperature has reached 130° F (55° C).	An alarm will be issued if the condition persists for 5 continuous seconds.
	Temp High	High oil temperature, in excess of 150° F (65° C).	Shutdown will occur if the condition persists for 60 continuous seconds.
	Recirc Press Low	Oil pressure to heat exchanger is low, 15 psi (1 bar).	Shutdown will occur.

Installing a New Battery

The following procedure is used to change the replacement battery.



Do not attempt to remove the permanent battery.

1. Insert the new battery into the replacement battery pocket with the wires facing up.

2. Insert the wire connector for the replacement battery into the connector port.
3. Secure the battery wires under the wire latch as shown in Figure 4-18, Replacement Battery.
4. All local regulations must be adhered to when disposing of the used battery.

Figure 4-18: Replacement Battery

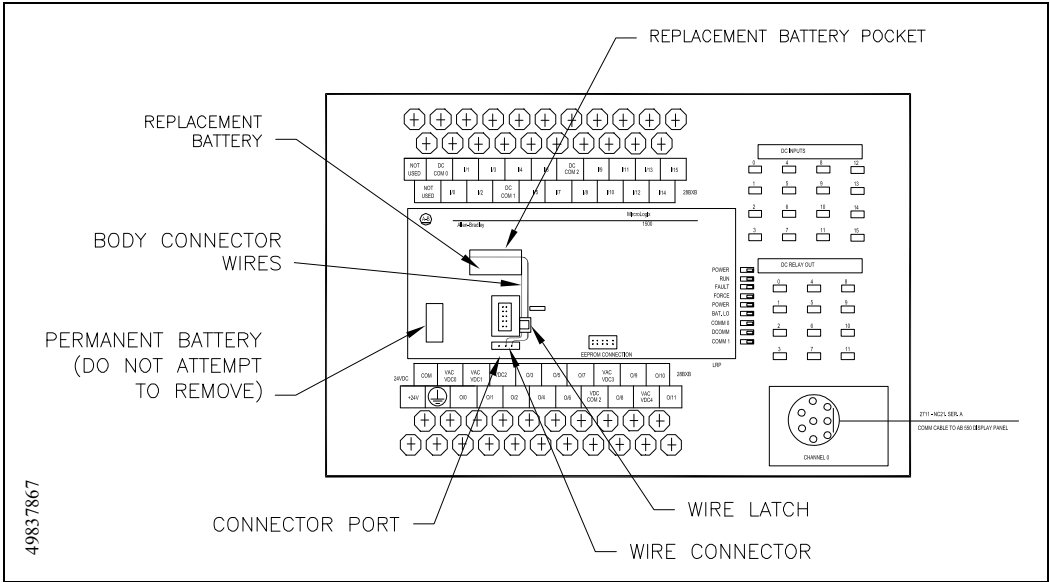

4.15 Stroke Rate Alarm Screen

Overstroke warnings, pending shutdowns and shutdowns are issued as left, right or intensifier. The Stroke Rate Alarm Screen isolates the overstroke warning.

Figure 4-19: Stroke Rate Alarm Screen

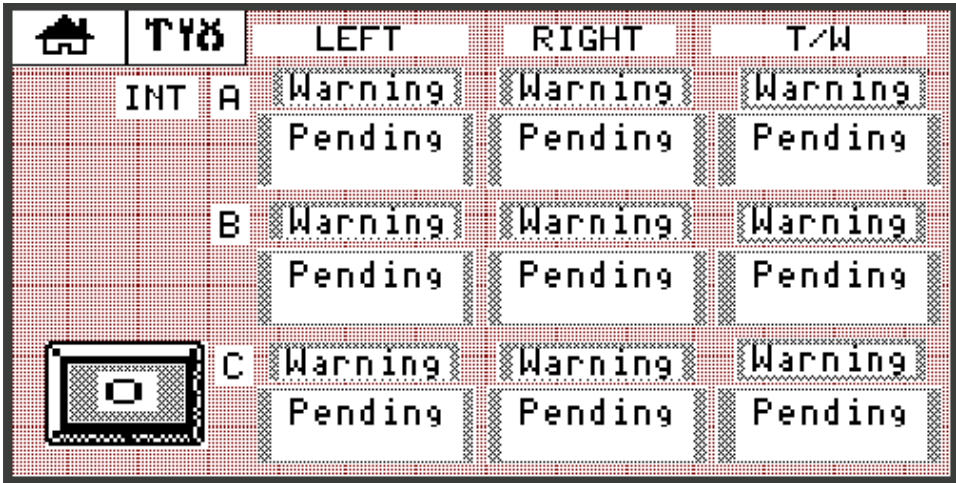

4.16 Alarm History Screen

The Alarm History Screen displays the last 100 shutdown alarms indicating date, time and type of alarm. Use the ▲ or ▼ arrow to view past alarms.

Figure 4-20: Alarm History Screen

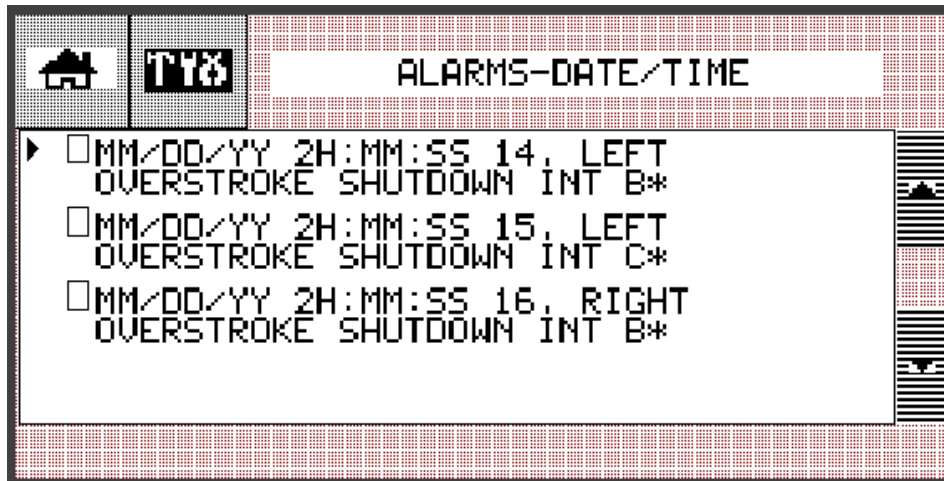

Changing the Date and Time

The following procedure is used to change the date and time.

1. Remove power from the display by pressing the E-STOP button.
2. Pull the E-STOP button out and press the RESET button to energize the display panel.
3. Shortly, the number 24 will display. Ten seconds later, the number 32 will replace the number 24 and a small blinking square will display on the bottom, right of the screen.
4. Press the blinking square to initialize the Configuration Screen used to set the parameters for the panel display.
5. Select Date/Time and press ENTER. Set the year, month, day, hour, minutes and seconds. Press EXIT to return to the previous screen.
6. Select Run Mode and press ENTER to return to the display panel.

4.17 Maintenance Screen

The Maintenance Screen is used to facilitate maintenance procedures and provides the PLC and display logic part and revision number. When started from the Maintenance Screen, the machine starts in maintenance mode and opens the safety dump valve.

Figure 4-21: Maintenance Screen

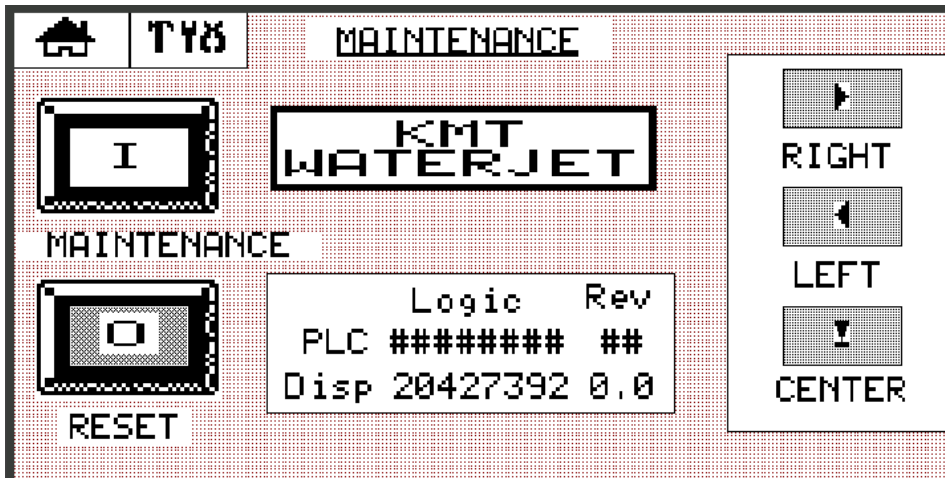

The machine must be started from the Maintenance Screen to access the following functions:

START	The START button will start the machine in maintenance mode and open the safety dump valve.
STOP	The STOP button will stop the machine.
RESET	The inlet water solenoid indicator. The inlet water solenoid valve is automatically closed five minutes after the machine shuts down. When RESET flashes, press the STOP button to reset and open the valve.
RIGHT	The RIGHT button will open the dump valve and extend the piston to the right, allowing full exposure to the right plunger when the unit is disassembled. <i>The unit must be completely assembled to use this jog function.</i>
LEFT	The LEFT button will open the dump valve and extend the piston to the left, allowing full exposure to the left plunger when the unit is disassembled. <i>The unit must be completely assembled to use this jog function.</i>
CENTER	The CENTER button will open the dump valve and position the piston in the center of the hydraulic cylinder. <i>The unit must be completely assembled to use this jog function.</i>

To center the piston, first press the right button and then the center button.

4.18 Language Screen

The Language Screen lists the available display languages. Press the ▲ or ▼ arrow to highlight the desired language. Press ENTER (↵) to select.

The PSI/BAR button displays the operating pressure in psi or bar. Press the button to select the desired pressure reading. The pressure reading selection cannot be changed while the pump is operating.

Figure 4-22: Language Screen

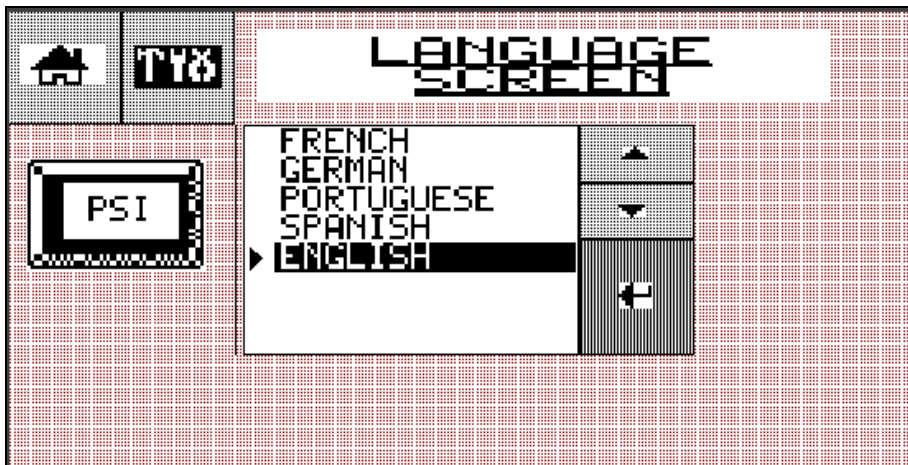

4.19 Contact Information Screen

Consult the Contact Information Screen for technical assistance, available 7 days a week, 24 hours a day.

Figure 4-23: Contact Information Screen





SECTION 5

LOW PRESSURE WATER SYSTEM

5.1 Overview

The SL-V 150 and 200 utilize two low pressure circuits: cutting water supply and cooling water supply. This section will discuss the cutting water supply circuit. See Section 6, Recirculation System, for a detailed explanation of the cooling water supply circuit.

The cutting water supply circuit, low pressure water system, supplies the intensifier with the required cutting water flow and pressure. System components include the strainer, inlet water solenoid valve, booster pump and auxiliary motor, the filter assembly and the low pressure manifold. Pressure and temperature switches, connected to the PLC, monitor out of tolerance conditions in the cutting water circuit and provide automatic shutdown protection.

Figure 5-1: Cutting Water Supply Circuit

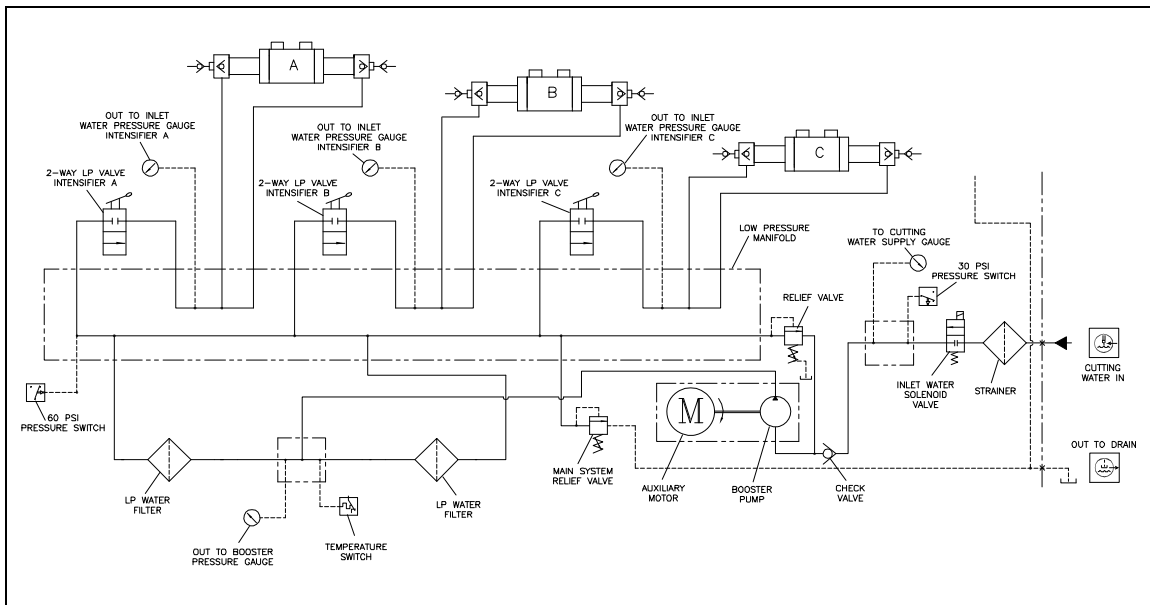

5.2 Cutting Water Supply

The quality of the inlet cutting water supply is one of the most important factors affecting component life and performance. Impurities in the water create abrasive and corrosive effects on all components. See Section 11, Specifications, for details regarding water quality standards.

5.3 Operation

Cutting water is introduced through the 1/2-inch NPT connection on the rear bulkhead of the machine. Inlet cutting water pressure should be a minimum of 35 psi (2.4 bar) flowing, and can be monitored from the Cutting Water Supply Gauge on the pressure gauge display.

Figure 5-2: Low Pressure Water System

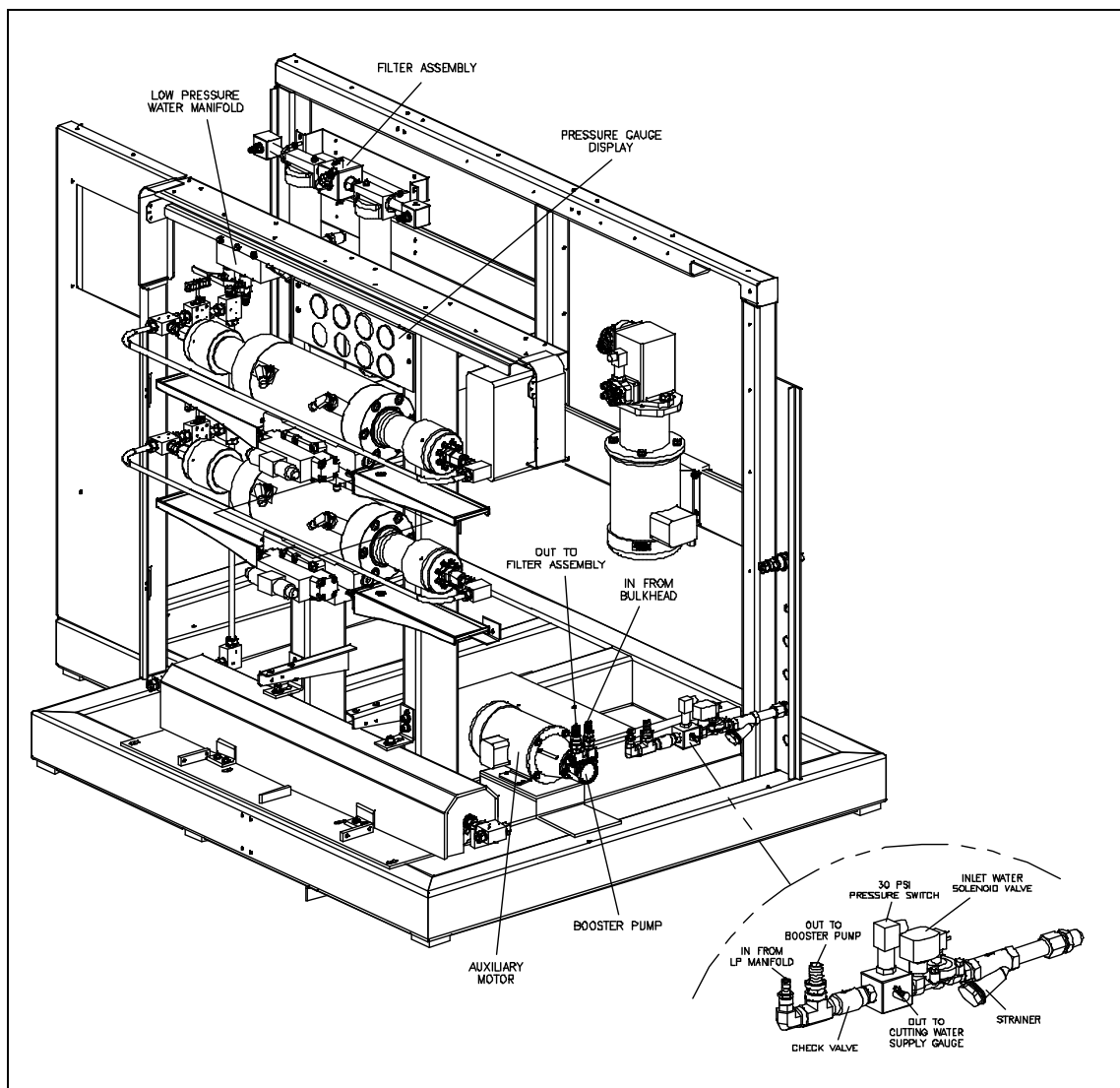

Cutting water initially passes through a strainer to remove debris before the water enters the booster pump. It then passes through the normally closed, inlet water solenoid valve. When the control power is turned on, the solenoid valve opens and allows water to flow through the valve. The inlet water is monitored by a 30 psi pressure switch. If the pressure drops below 30 psi (2 bar) the switch activates an automatic shutdown circuit in the PLC and the machine will not start.

NOTE

The machine will not start if inlet cutting water pressure is below 30 psi (2 bar).

If a shutdown occurs due to an overstroke condition, the inlet solenoid valve automatically closes to prevent water waste due to an external leak. Additionally, the valve automatically closes after five minutes of inactivity when the water reset function is enabled at the control panel.

Cutting water enters the booster pump where the pressure is increased to the relief valve setting, up to a maximum of 120 psi (8 bar), to ensure proper supply to the intensifier assembly. Boosted pressure is displayed on the Booster Pressure Gauge on the gauge display. The gauge should read approximately 120 psi (8 bar) while the machine is idling. The pressure will drop when the intensifier assembly strokes. Pressure is restored between strokes.

NOTE

While the intensifier assembly reverses direction, the boosted pressure will fluctuate above and below the normal setting.

Pressurized water is then routed to the low pressure filter assembly where a temperature switch monitors the boosted water temperature. If the temperature exceeds 128° F (53° C), the switch activates an automatic shutdown circuit in the PLC that stops the main motor. The temperature switch prevents booster pump overheating due to lack of water or long deadhead conditions.

Figure 5-3: Low Pressure Filter Assembly

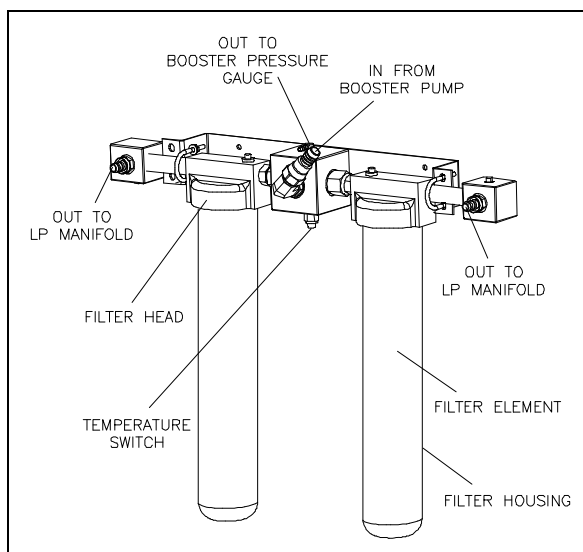

The water passes through two filter assemblies where debris is removed to prevent contaminants from damaging the check valves and seals in the intensifier. Each filter assembly consists of a filter head, housing and 10-micron filter. A bleed valve on the top of the filter head releases pressure or air inside the housing.

From the filter assembly, pressurized water is routed to the low pressure manifold. As the water enters the manifold, the pressure is monitored by a 60 psi pressure switch. An automatic shutdown will occur if the pressure is below 60 psi (4 bar).

Figure 5-4: Low Pressure Manifold

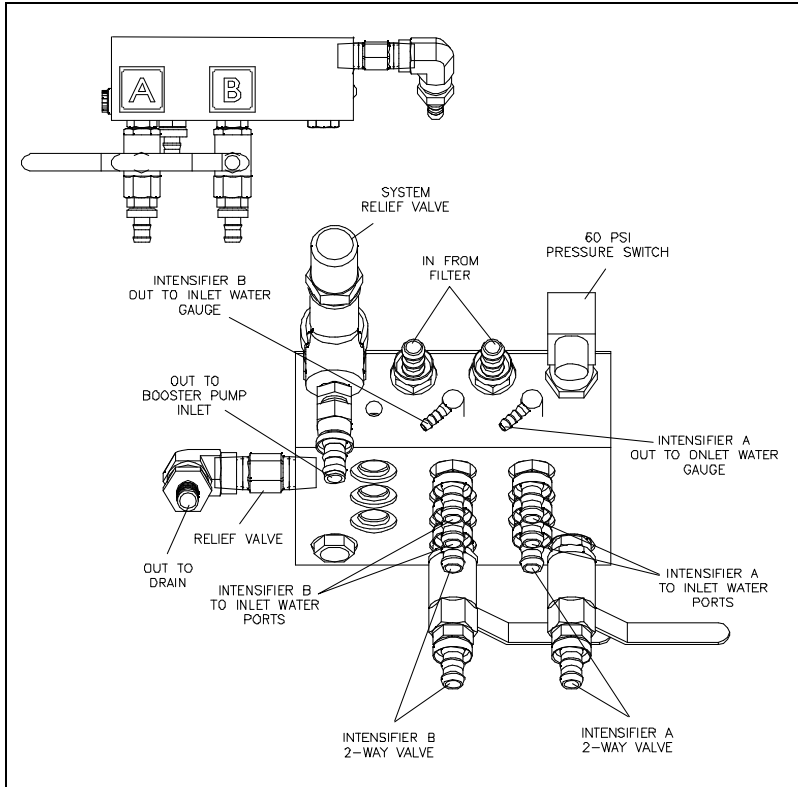
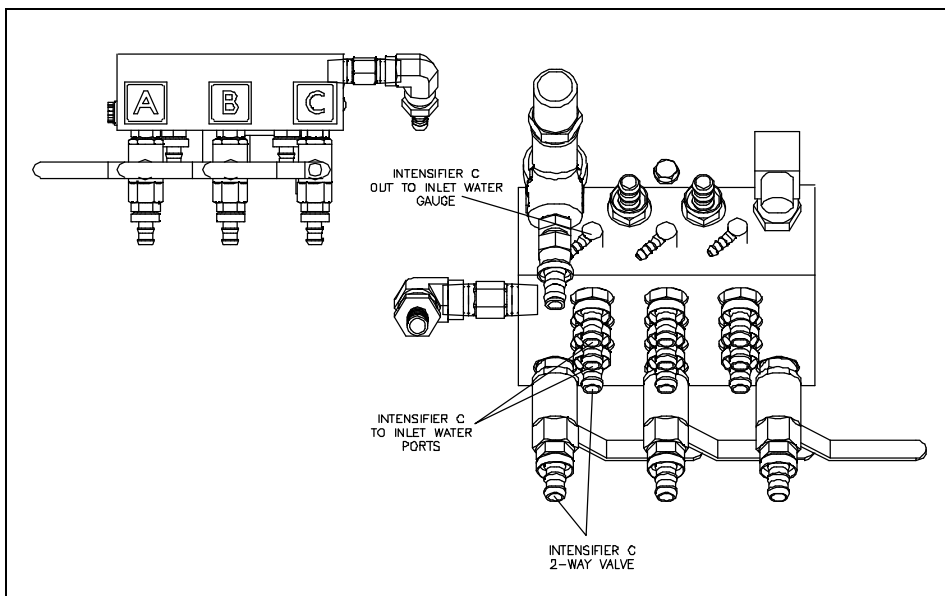

Figure 5-5: Redundant Low Pressure Manifold



If the boosted pressure exceeds 125 psi (8.6 bar) a relief valve opens allowing water to exit through the 1/2-inch drain connection on the rear bulkhead. It is still possible to operate the machine; however, excess water will continue to be released through the drain.

The main system relief valve prevents excessive discharge pressure and typically operates when the machine is in a deadhead condition. To reduce overheating, water is routed back to the booster pump inlet and re-circulated. The relief valve is factory set and may require adjustment to satisfy system requirements.

From the low pressure manifold, cutting water is routed to the inlet water ports on each end of the intensifiers. The 2-way valves on the manifold are opened or closed to direct the flow to the active intensifier(s).

The pressure gauge display on the front of the machine allows the operator to observe the cutting water pressure as it flows through the low pressure system. The gauges monitor the inlet cutting water supply, the booster pressure and the inlet pressure to each intensifier. Additionally, the hydraulic oil pressure to each intensifier is displayed.

Pressure drop across the low pressure filters can be monitored by comparing the booster pressure and the inlet pressure to any intensifier.

Figure 5-6: Pressure Gauge Display

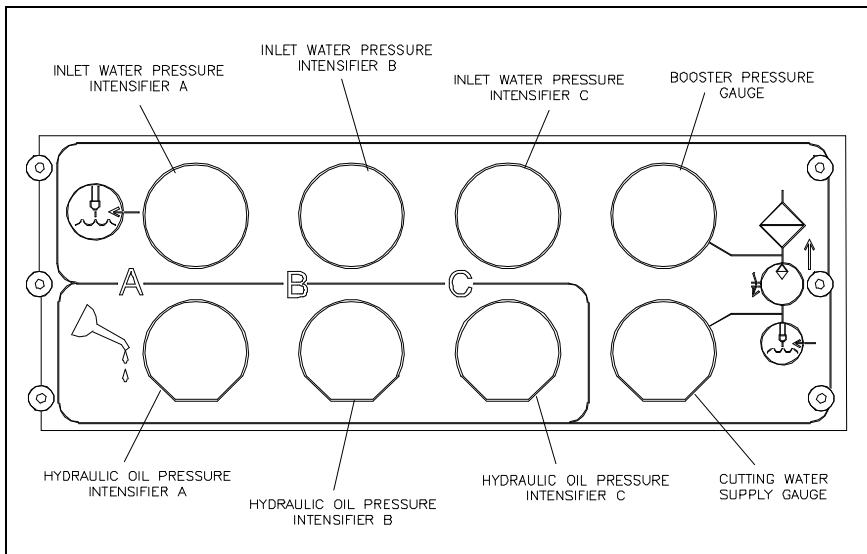

5.4 Service and Maintenance Procedures

To ensure water quality and supply to the high pressure system, the filter element, strainer and system relief valve will require routine servicing and maintenance. The procedures for servicing these components are detailed below.

NOTE

Refer to Section 12, Parts List for a complete listing of replacement parts and part numbers.

Filter Assembly

The life of the filter elements is directly related to the quality of the inlet water. The condition of the filter elements can be monitored by comparing the booster pressure gauge and the inlet water pressure gauges for the individual intensifiers. Replace the elements when the pressure differential between the booster pressure gauge and the inlet water gauges exceeds 15 psi (1 bar). Both filter elements should be replaced at the same time.

Figure 5-7: Filter Element

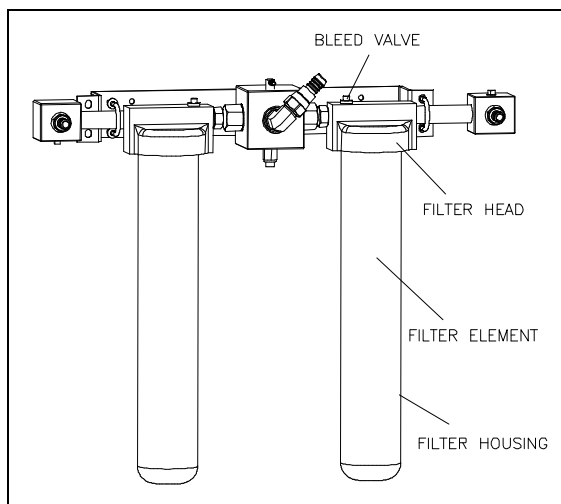

1. Turn the cutting water supply off.
2. Press the red bleed valve on the filter head to release any pressure trapped inside the housing.
3. Use a filter wrench to unscrew the housing and remove the old element.
4. Install the new element. Apply FML-2 grease to the o-ring in the filter housing and use the filter wrench to replace the housing.

NOTE

To ensure proper alignment of the element, fill the filter housing approximately 1/4 to 1/3 full of water. When the element is installed it will float, allowing it to be centered while the housing is installed on the filter head.

5. Turn the cutting water supply on.
6. Press the red bleed valve to remove any air inside the housing.
7. Repeat this procedure to replace the element in the second filter assembly.
8. Start the machine and verify satisfactory pressure readings.

Strainer Maintenance

Clean the strainer each time the filter elements are replaced.

Figure 5-8: Strainer

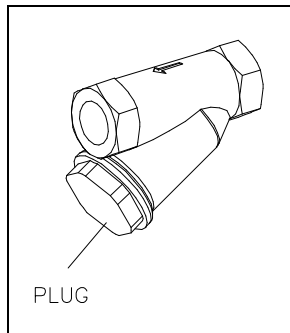

1. Turn the cutting water supply off.
2. Unscrew and remove the strainer plug and seal ring. Remove and clean the mesh liner.
3. Install the liner. Ensure the seal ring is properly positioned; replace the plug and hand-tighten.
4. Turn the cutting water supply on.

Relief Valve Adjustment

If the discharge pressure from the booster pump remains below 90 psi (6 bar) while the intensifier is shifting, the main system relief valve on the back of the low pressure manifold must be adjusted.

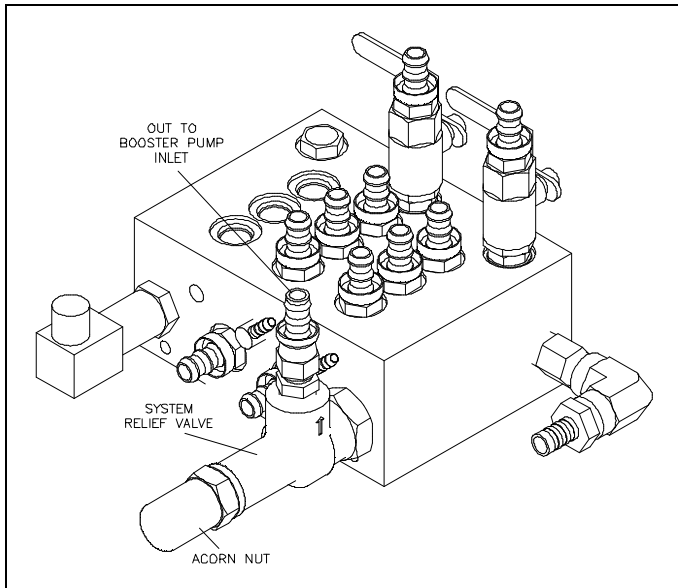
Figure 5-9: Relief Valve

1. Start the machine, begin normal operation and observe the discharge pressure from the booster pump.
2. Stop the machine, loosen and remove the acorn nut to access the adjustment screw.
3. Loosen the nut on the adjustment screw. Use a flat screwdriver and turn the adjustment screw clockwise to increase the discharge pressure or counter-clockwise to decrease the pressure. Adjust the pressure to the highest desired pressure, within normal booster pump range.
4. Tighten the nut on the adjustment screw, replace and tighten the acorn nut.
5. Resume normal operation and observe the discharge pressure. Peak pressure should be in the range of 90 to 120 psi (6 to 8 bar). Repeat the adjustment procedure if necessary.



SECTION 6

RECIRCULATION SYSTEM

6.1 Overview

The oil recirculation circuit is a cooling and filtration system that provides properly conditioned oil to the hydraulic system. Hydraulic oil is maintained at the proper operating temperature and condition by continuous recirculation.

System components include the water modulating valve, heat exchanger, oil filter assembly, recirculation pump and auxiliary motor, and the hydraulic oil reservoir. Automatic shutdown protection is provided by a temperature/low level switch that monitors temperature and oil level conditions in the hydraulic oil reservoir and a pressure switch that monitors oil pressure to the heat exchanger.

Figure 6-1: Oil Recirculation Circuit

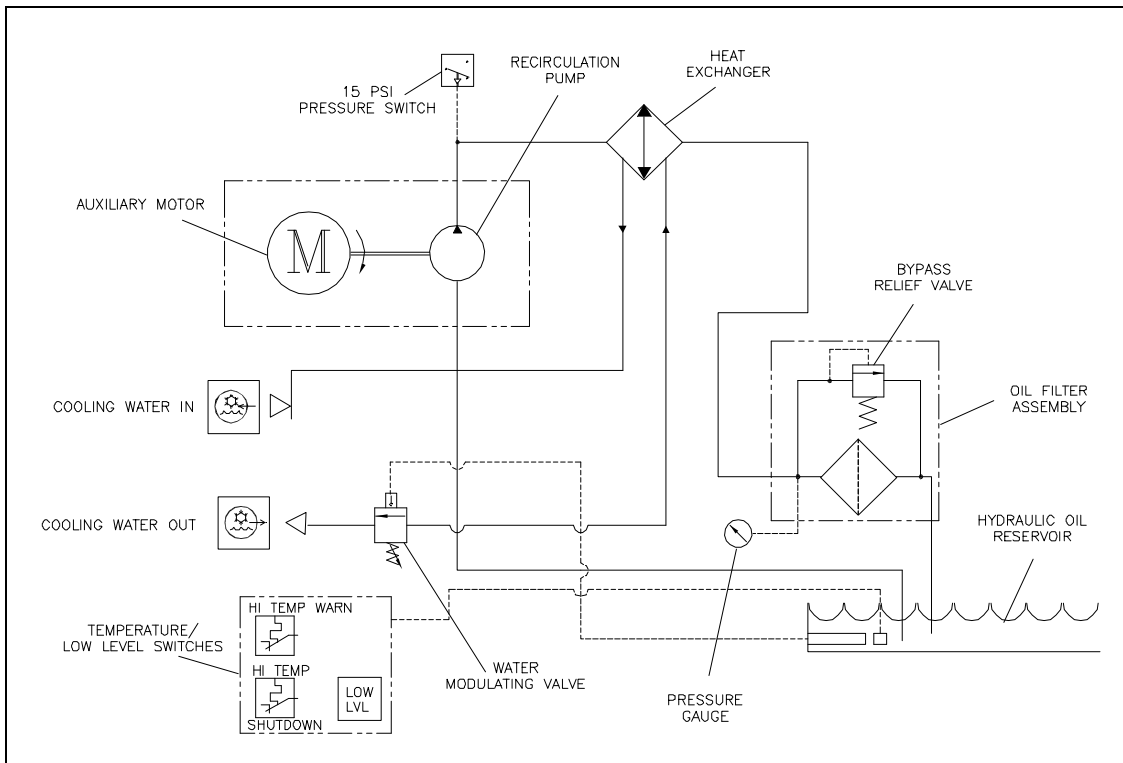

6.2 Operation

Cooling water is introduced through the 1/2-inch NPT connection on the rear bulkhead of the machine. A water modulating valve in the outlet line regulates the cooling flow through the heat exchanger. The valve is factory set, but may require adjustment to maintain the operating oil temperature at 115° F (46° C). Oil temperature can be visually monitored from a dual scale level/temperature sight gauge on the side of the hydraulic oil reservoir.

Figure 6-2: Recirculation System Components

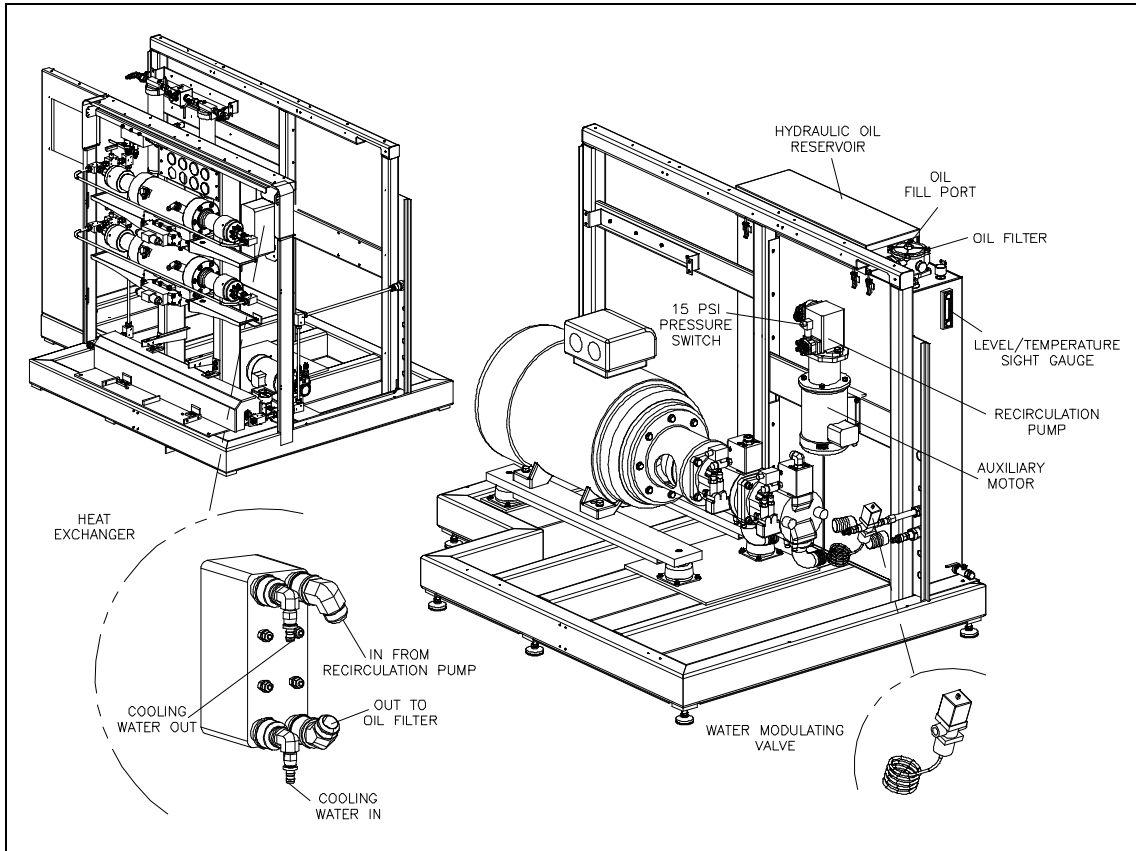

The recirculation pump, driven by an auxiliary motor, pulls oil from the reservoir and sends it to the heat exchanger. A pressure switch monitors the oil pressure going to the heat exchanger. An automatic shutdown occurs if the pressure falls below 15 psi (1 bar). The oil-to-water heat exchanger controls heat build-up in the hydraulic oil. The plate style design allows cooling water and oil to flow side by side through alternating plates.

The cooled oil then passes through the filter element and returns to the reservoir. The cooling water either is discharged to the 1/2-inch NPT drain on the rear bulkhead or is routed to a customer supplied water chiller.

The hydraulic oil filter assembly consists of the filter head, filter element, pressure gauge and a bypass relief valve. The filter element should be changed when the gauge reads 40 psi (2.8 bar) at normal operating temperature. If the element is not replaced, and fills with debris, the bypass relief in the filter head will open to prevent over pressurization. The relief valve opens at 43 psi (3 bar). When the valve opens, the oil bypasses the filter and unfiltered oil is allowed to return to the reservoir.

The temperature/low level switch monitors the oil temperature and level in the reservoir. A warning is issued if the operating oil temperature exceeds 130° F (55° C), an automatic shutdown will occur at 150° F (66° C). An automatic shutdown will also occur if the oil level falls below 110 gal (416 L).

NOTE

To conserve water usage it is recommended that the cooling water be shut off at the end of the day. A sensor bulb from the modulating valve is submerged in the reservoir. Even when the control power is off, the valve will remain open, allowing water to flow until the oil is cooled.

6.3 Service and Maintenance Procedures

To ensure the supply of properly conditioned oil to the main hydraulic system, the components in the recirculation system will require routine servicing and maintenance. The procedures for servicing these components are detailed below.

NOTE

Refer to Section 12, Parts List for a complete listing of replacement parts and part numbers.

Hydraulic Oil Maintenance

The hydraulic oil should be replaced after 3,000 hours or one year of service, whichever comes first. The oil should be replaced sooner if a fluid sample indicates contamination that cannot be rectified by filtering.

An air breather and filter are located on the top of the reservoir. The air breather prevents dirt from being sucked into the reservoir when the oil level drops, and allows air to escape when the level rises. The air breather must not be used as a fill point. Oil **must only** be replaced at the fill port on the filter head.



Do not attempt to fill the reservoir from the air breather. The oil will not be filtered and will not conform to the cleanliness requirements of the system.

Figure 6-3: Hydraulic Reservoir

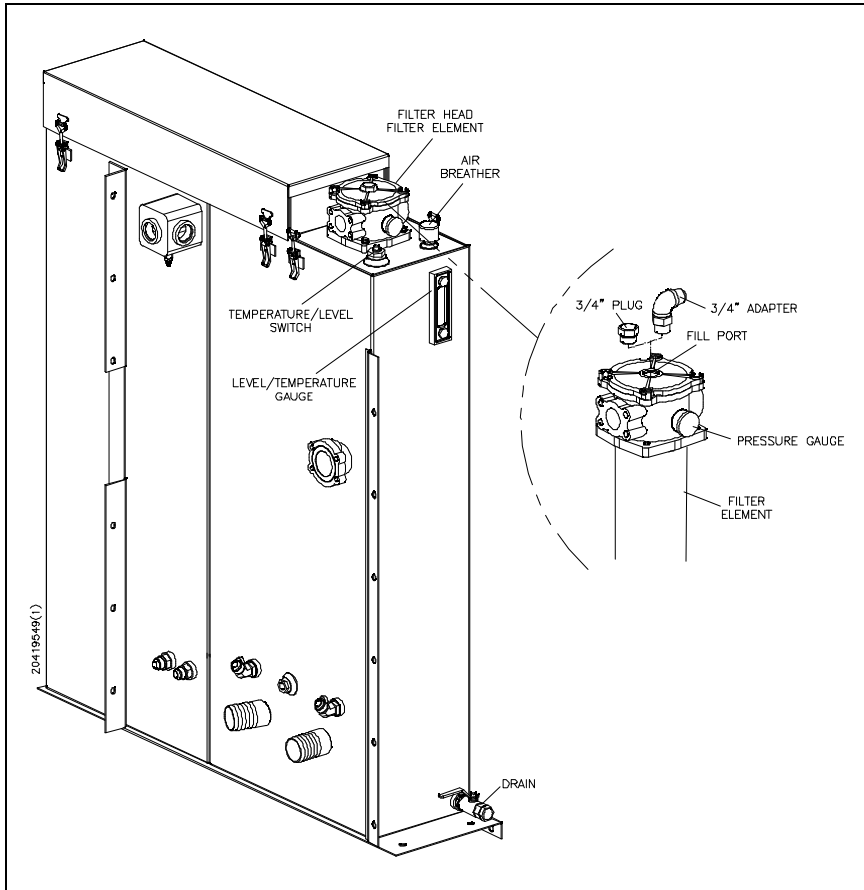

1. Turn the machine off and observe the appropriate Lockout/Tagout procedures.



Severe injury can result if the machine is not properly locked out. Observe electrical Lockout/Tagout procedures before performing maintenance.

Ensure all pressure is relieved or blocked from the hydraulic and high pressure circuits before performing maintenance.

2. Drain the oil reservoir by removing the plug on the reservoir drain valve and connecting the inlet hose from an oil transfer pump to the drain valve.
3. Open the 2-way valve on the drain and pump the used oil out to a container.
4. Close the 2-way valve and remove the hose from the drain.

NOTE

Typically, oil from a new drum does not meet the cleanliness requirements of the hydraulic system. For this reason, it is important to use the oil transfer pump that will force oil through the return filter into the reservoir.

5. Remove the 3/4 inch plug from the fill port on the filter head and install the 90-degree adapter provided.

NOTE

A stepladder or platform will be required to access the fill port on the oil filter.

6. Connect the discharge hose from the oil transfer pump to the adapter and pump the fresh oil into the reservoir.



To ensure cleanliness, the oil fill port **must** be used to pump oil into the reservoir. Filling at this point guarantees the hydraulic oil will pass through the oil filter before entering the reservoir.

7. Check the oil sight gauge on the reservoir to ensure proper fill level.
8. Remove the hoses from the case drains on the hydraulic pumps to make sure the pump cases fill with oil. With the hose removed, head pressure from the reservoir will force oil into the pump case.

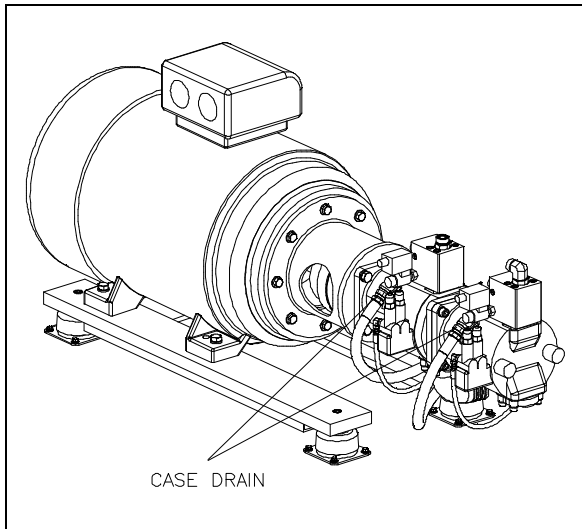
Figure 6-4: Case Drain

Oil in the pump case provides internal lubrication for the hydraulic pump. Failure to fill the pump case with oil will allow air to become trapped inside, damaging the pump.

9. Disconnect the discharge hose from the fill port, remove the adapter and replace the fill port plug.
10. Follow the initial startup sequence in Section 4, Operation, to ensure the system is filled with oil.
11. Check the sight gauge again and follow the same procedure to add additional oil if necessary.

Electric Motor Bump

Bumping is defined as allowing the electric motor to start rotating, but stopping it before the motor gets up to full speed.

Whenever the hydraulic reservoir is emptied or the hydraulic pump has been changed, bumping the electric motor is suggested. This procedure will ensure the hydraulic pump is full of oil and deter cavitation which will cause the hydraulic pump to fail prematurely.

Do not perform this procedure until the correct motor rotation and the presence of hydraulic oil in the hydraulic pump case drain line has been confirmed.

1. Start the pump in recirculation mode, count two seconds and turn the pump off.
2. Repeat this process six times before allowing the hydraulic pump to create pressure.

Oil Filter Maintenance

If the filter element is not properly serviced and fills with debris, the oil will be forced through the relief valve, bypassing the filter. The bypass relief valve opens at 43 psi (3 bar). The filter element must be replaced when the pressure gauge reads 40 psi (2.8 bar) at normal operating temperature.

Figure 6-5: Oil Filter Replacement

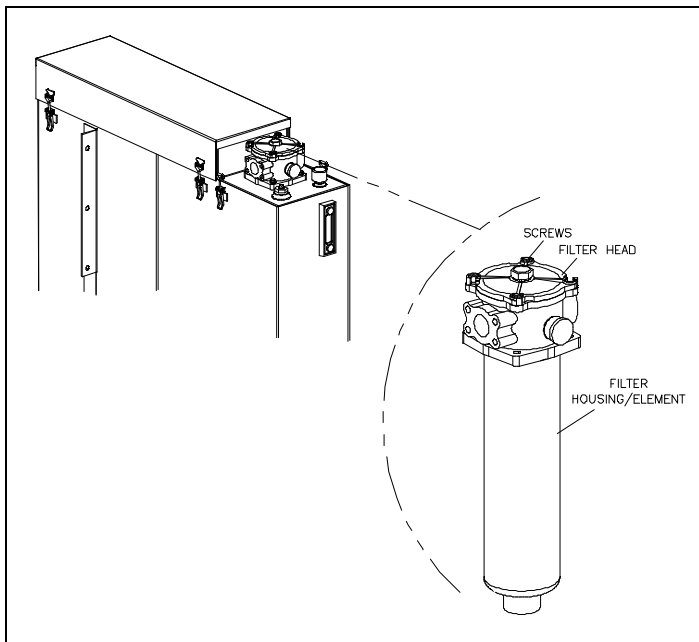

NOTE

A stepladder or platform will be required to access the filter head and oil filter element.

1. Loosen the four screws on the filter head. Do not remove the screws.
2. Rotate the filter head counter-clockwise and remove.
3. Remove the spring and the cap inside the filter housing, and then remove the filter element.
4. Position the cap on the top of the new filter element and install the components in the housing.
5. Align the spring on the top of the cap.
6. Install the filter head, compressing the spring until the filter head is properly positioned.
7. Rotate the filter head clockwise. Hand-tighten the four screws.

8. Start the machine and check for leaks.

Operating Temperature Adjustment

The cooling water flow through the heat exchanger is regulated by the water modulating valve, a manually adjusted, thermostatic control valve. The valve is factory set to maintain the operating oil temperature at 115° F (46° C). It is adjusted by increasing or decreasing the spring tension on the valve.

Figure 6-6: Water Modulating Valve

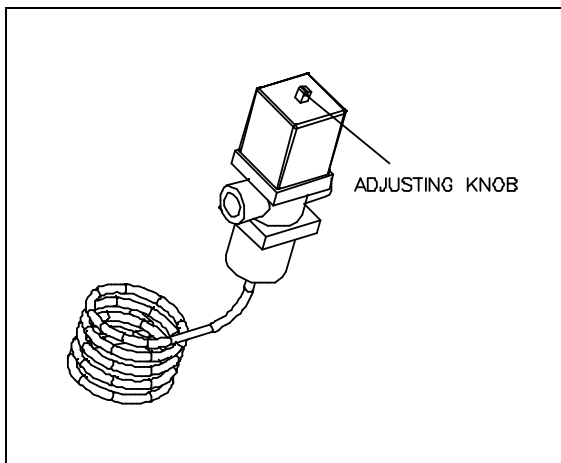

1. Locate the adjusting knob, a screwdriver slot on the top of the valve.
2. Use a flat screwdriver and turn counter-clockwise to compress the spring, slowing water flow and increasing temperature. Turn clockwise to reduce spring tension, increasing water flow and decreasing the temperature.
3. Monitor the sight gauge on the side of the reservoir until the adjusted temperature can be determined. It will take some time for the temperature in the oil reservoir to change.
4. Repeat steps 2 and 3 if necessary.



SECTION 7

HYDRAULIC SYSTEM

7.1 Overview

The main hydraulic power circuit supplies the intensifier assembly with the hydraulic oil required to produce high pressure water. High pressure cutting water is generated from the oil pressure in the hydraulic cylinder.

System components include the main electric motor, 4-way directional control valves, two hydraulic pumps with hydraulic manifolds. Each manifold houses a proportional pressure control valve and a system relief valve. The system relief valve monitors hydraulic oil pressure and provides system protection by limiting excess pressure.

Figure 7-1: Main Hydraulic Power Circuit

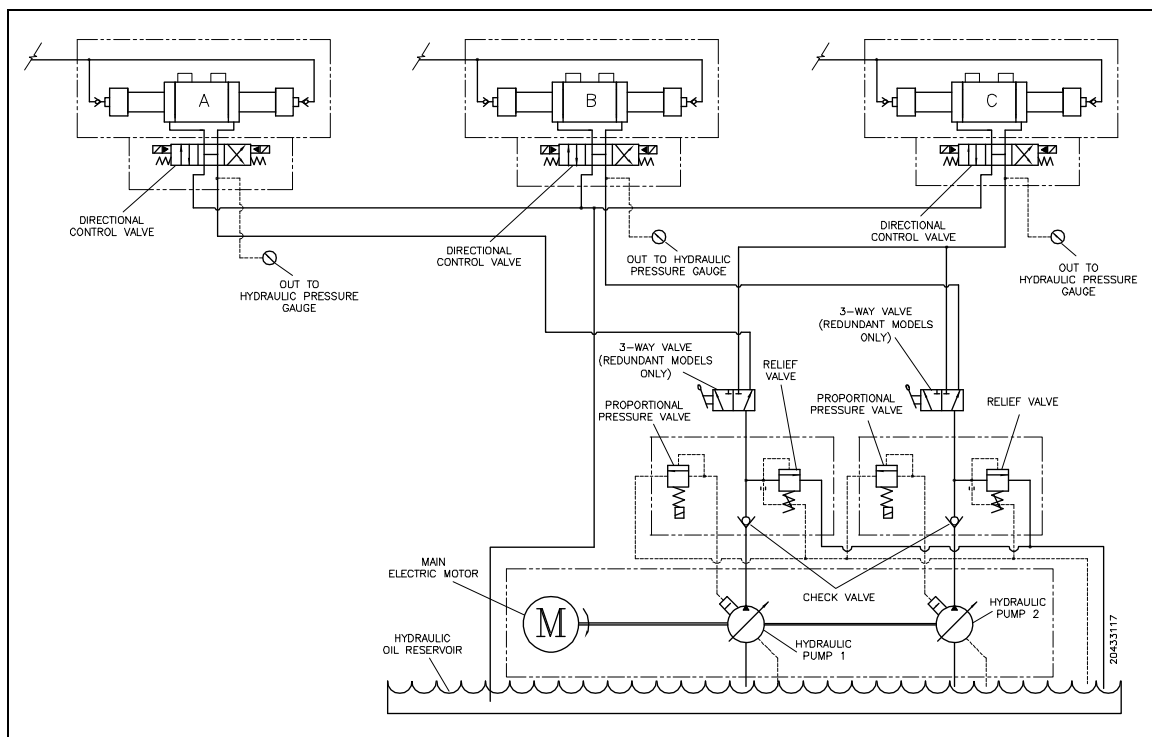

7.2 Operation

The main motor and two hydraulic pumps are mounted in tandem. The motor drives the variable displacement, pressure compensated hydraulic pumps by means of a flexible coupling. Hydraulic pump 1 supplies intensifier A, and pump 2 supplies intensifier B.

Hydraulic fluid from the reservoir is drawn into the inlet, low pressure side of each hydraulic pump. Oil delivered to the pumps should be maintained at 110-115° F (43-46° C). Hydraulic fluid then enters the bottom of the hydraulic manifold through an internal anti-rotation check valve. After a shutdown, the anti-rotation check valve prevents the hydraulic pumps from running backwards.

Figure 7-2: Hydraulic System Components

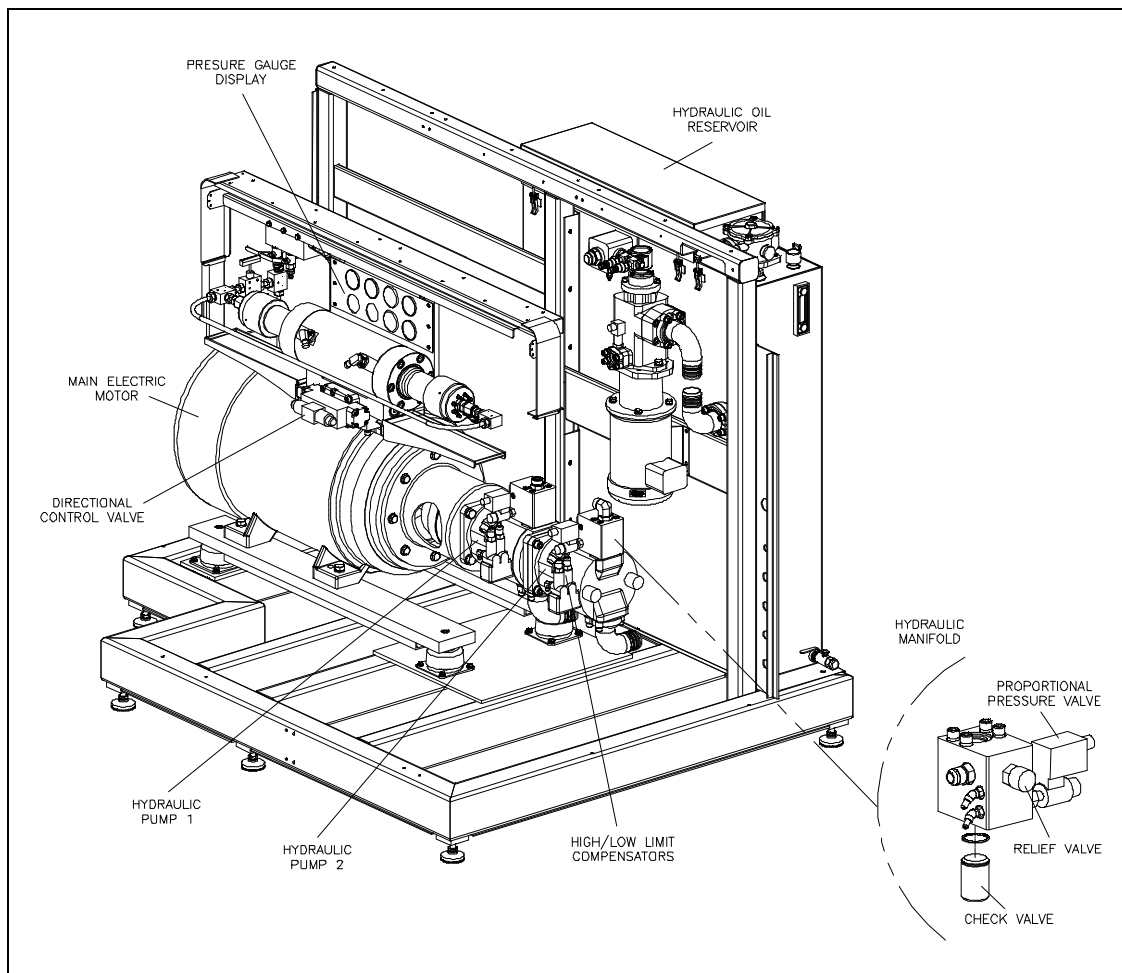

The relief valves provide system protection by monitoring the oil pressure entering each manifold. If the hydraulic pressure to either pump exceeds 3,400 psi (234 bar), the valve opens to limit the pressure. The valves are factory calibrated and are not serviceable. A drain line from the valve prevents oil from collecting behind the relief valve to ensure a constant pressure under all operating conditions.

The high and low limit compensators mounted on each pump regulate the flow of hydraulic fluid to maintain constant operating pressures. Operating pressure is set and adjusted from the control panel or a remote console. As the proportional pressure valves control the hydraulic oil pressure, they also determine cutting water pressure based on the intensification ratio.



The high and low limit compensators, along with the proportional pressure valves, regulate the flow of hydraulic fluid to the system by controlling the angle of the swashplate. If the oil is not properly maintained, the compensators can become blocked with debris. As a result, pump control will be lost and you will not be able to create hydraulic oil pressure.

Hydraulic reference gauges display the hydraulic pressure to each intensifier. When the intensifier shifts, it is normal for the pressure to quickly fall and then rise again.

Figure 7-3: Pressure Gauge Display

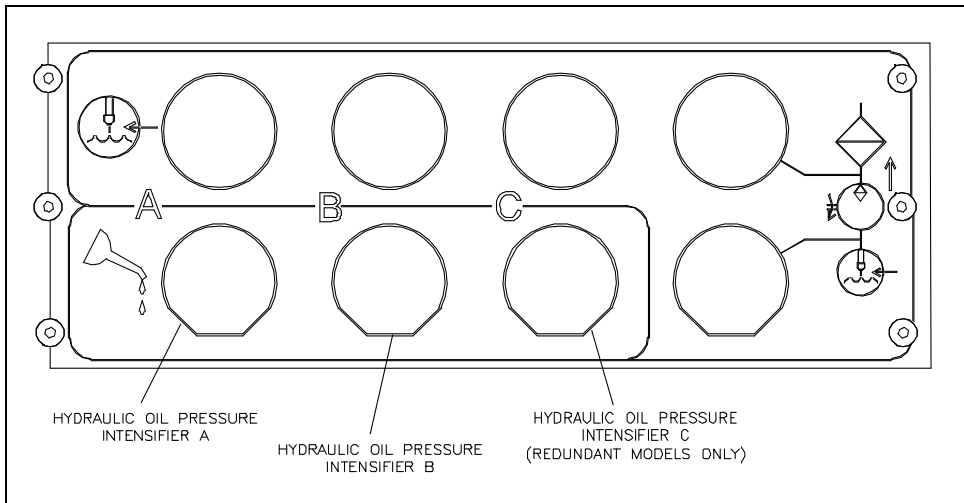

The 4-way directional control valves direct pressurized oil to one end the hydraulic cylinder, and return fluid to the reservoir from the opposite end, causing the intensifier to stroke. The movement is controlled hydraulically by a pilot valve that is electronically operated by two solenoids, energized by the PLC. Indicators light up as each solenoid is energized.

The directional control valve sends flow to the hydraulic cylinder in one direction until the hydraulic piston activates the proximity switch at the end of the stroke. The activated switch sends a signal to the PLC to reverse the direction of flow. The piston then moves in the opposite direction until it activates the proximity switch at the opposite end of the stroke.

Redundant Models

Redundant models utilize 3-way valves, mounted on the manifolds to direct the hydraulic flow to the active intensifiers. The valves are positioned to correspond to the selected intensifier configuration. On redundant models, hydraulic pump 1 supplies intensifier A or C, hydraulic pump 2 supplies intensifier B or C.

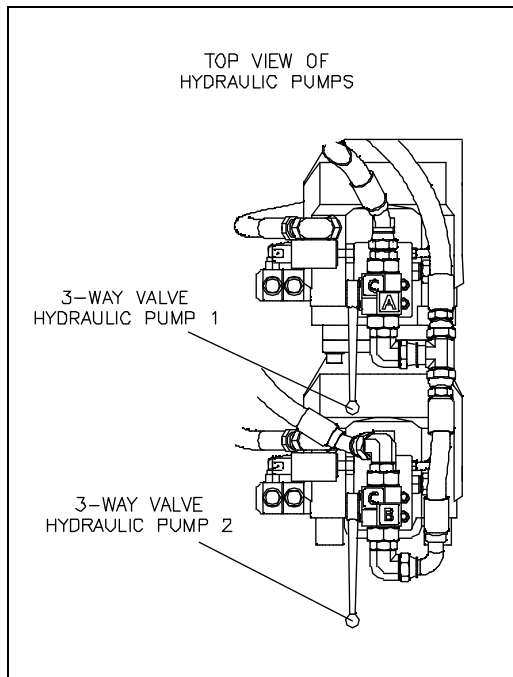
Figure 7-4: Hydraulic Valves

7.3 Service and Maintenance Procedures

The extreme duty cycles demanded of the hydraulic system make routine inspection and maintenance acutely important. Leaks must be detected and remedied as soon as possible.

The operating pressure setting must be checked daily, and the electric motors must be inspected at regular intervals.

NOTE

Refer to Section 12, Parts List for a complete listing of replacement parts and part numbers.

Proportional Valve Maintenance

The screen in the proportional valves can become clogged resulting in erratic pressure or the inability to reach or maintain the operating pressure. If there is a continuous 10-percent or greater difference in the percent out between two intensifiers, the screen in the proportional valve displaying the lower percent should be cleaned. The percent out can be observed on the Capacity Screen.

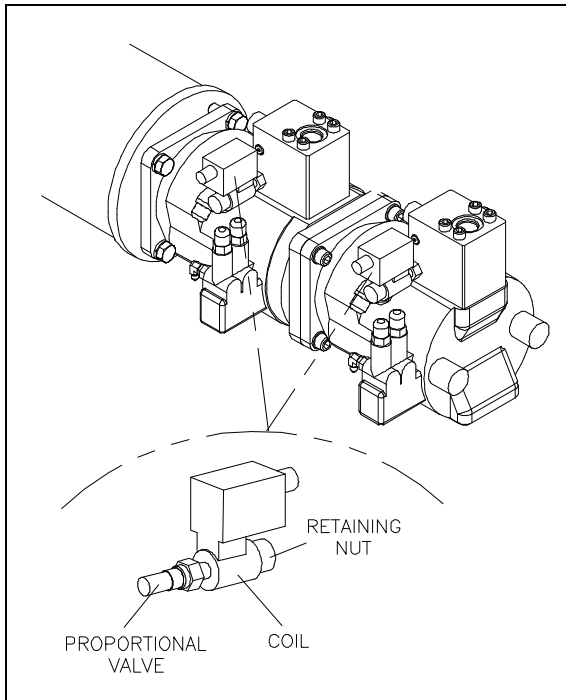
Figure 7-5: Proportional Valve

1. Turn the machine off and observe the appropriate Lockout/Tagout procedures.



Severe injury can result if the machine is not properly locked out. Observe electrical Lockout/Tagout procedures before performing maintenance on the system components.

Ensure all pressure is relieved or blocked from the hydraulic and high pressure circuits before performing maintenance.

2. Unscrew and remove the retaining nut and o-ring on the proportional pressure valve.
3. Remove the coil and electronic valve from the proportional valve.
4. Unscrew and remove the proportional valve from the manifold on the hydraulic pump.



Oil will leak from the manifold when the valve is removed. If the pump has been running, the oil will be hot.

5. Use air or alcohol to clean the screen inside the valve.

NOTE

A clogged screen will appear black. Clean the screen until it is clear.

6. Screw the cleaned valve into the manifold.
7. Replace the coil.
8. Replace the o-ring and retaining nut.

Motor Maintenance

The main and auxiliary motors should be inspected at regular intervals, approximately every 500 hours of operation or every three months, whichever occurs first. Keep the motors clean and the ventilation openings clear.



SECTION 8

ELECTRICAL SYSTEM

8.1 Overview

The SL-V 150 and 200 are equipped with integral motor starter and control circuitry, enclosed in the electrical panel. The operator controls the machine primarily through a touch-screen control panel that communicates with the programmable logic controller (PLC). A series of sensors provide information to the PLC for automatic shutdown logic and diagnostics.

Major system components include the main electric motor, two auxiliary motors, control panel, high voltage and control components, and the wiring harness that connects the sensors and solenoid valves to the PLC.

8.2 Operation

Electrical power from the utility grid enters the main circuit breaker/disconnect on the electrical enclosure door as 3-phase alternating current. The power is then distributed in two directions. The 3-phase AC, at the voltage provided from the grid, is routed to the motor starter contactor(s) and then to the main motor. Single phase AC is routed to the transformer.

Figure 8-1: Electrical Control Power

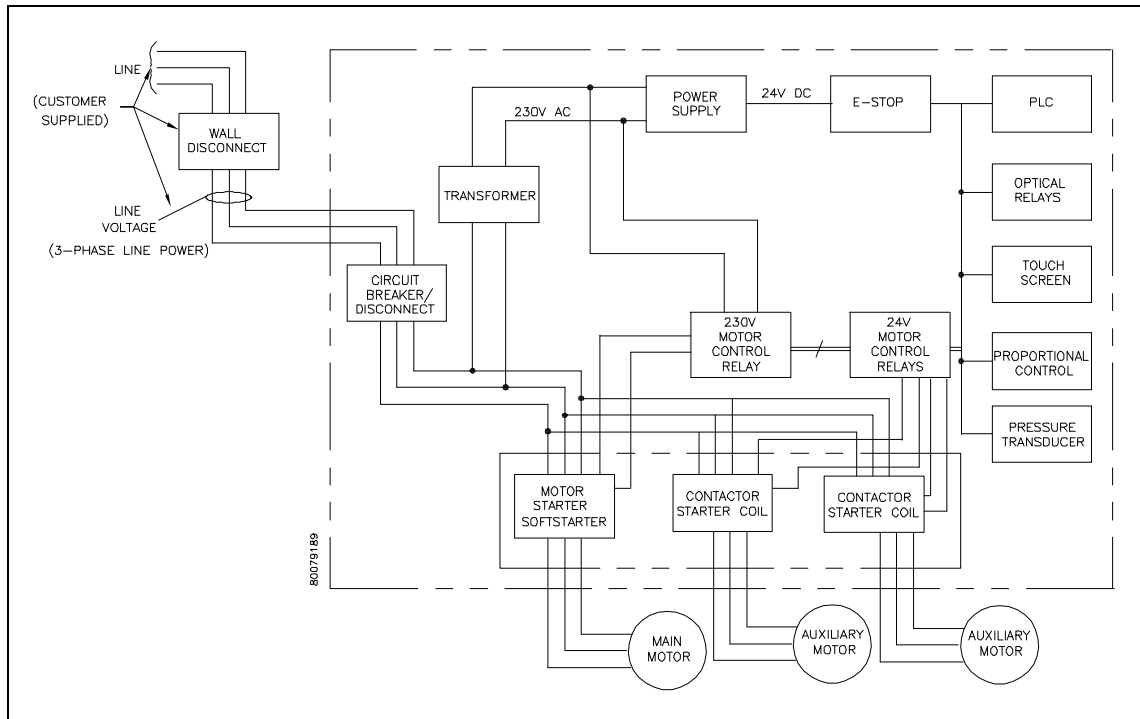

The multi-tap transformer converts the incoming voltage to 230 volt AC that is routed to both the softstarter and softstarter fan, and to the power supply. The power supply then provides 24 volt direct current to the control circuits, including the auxiliary motor contactors, emergency stop logic, the Programmable Logic Controller (PLC), optical relays, display screen and the control functions.

The main motor is started with a softstarter, operated by 230 volt AC control power. Softstarters combine contactors, overload, timers and internal power/control wiring into a single device. They utilize a current limit starting method to greatly reduce mechanical and electrical shock to the system.

When the START button is pressed on the display panel, an output from the PLC energizes the coils on the auxiliary motor contactors that starts the recirculation and booster pumps. Ten seconds later an output from the PLC closes a relay and 230 volt AC control power energizes the softstarter, starting the main motor. When the STOP button is pressed, the softstarter relay and the auxiliary contact coils open, stopping all motors.

Figure 8-2: Softstart Configuration

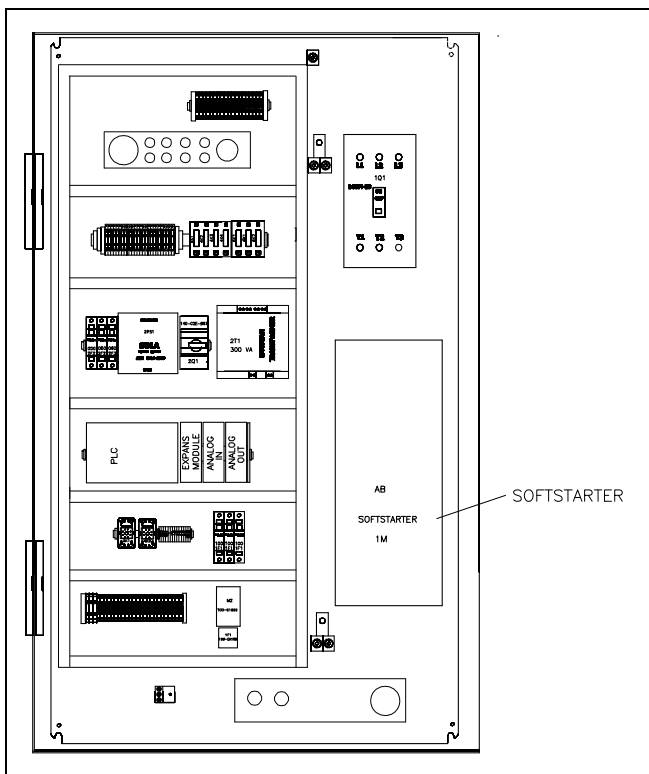

The circuit breaker/door disconnect provides the primary over current protection for the machine. All power is automatically disconnected from the machine when the main disconnect on the enclosure door is opened. However, power is still present on the input side of the circuit breaker/door disconnect. The only way to isolate all power to the machine is to turn the customer installed main power disconnect off.



Hazardous voltage exists in the motor circuit even when the softstart controller is off. Disconnect the main power before servicing the motor controller or associated wiring.

Figure 8-3: Electrical Enclosure Door

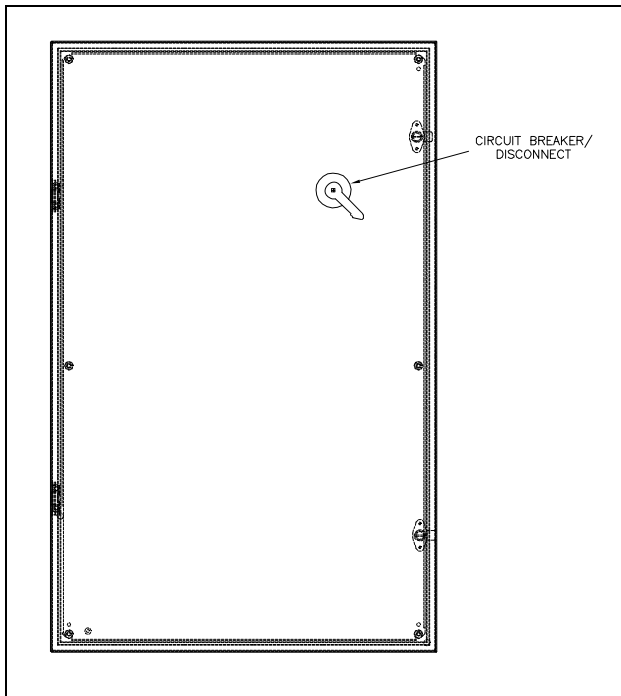

NOTE

See Section 2, Installation, regarding specifications for the customer installed main power disconnect.

Sensors and Solenoids

Warning and shutdown sensors monitor operating conditions, and electronically operated solenoids provide basic intensifier shift control. The harness cable connects these sensors and solenoids to the PLC.

Figure 8-4: Sensors and Solenoids

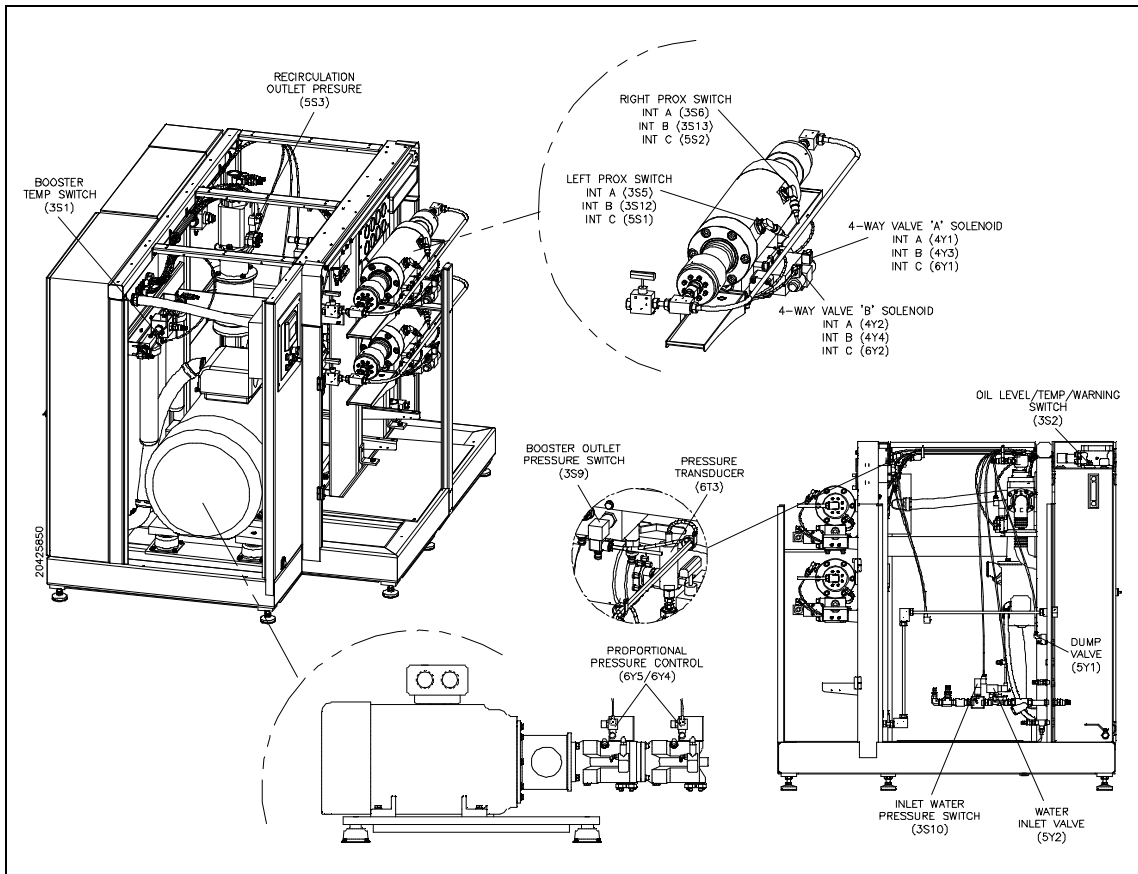

Table 8-1
Sensors and Solenoids

Component	Function
	<p>1 As pressurized hydraulic oil is sent to one side of the hydraulic cylinder, it pushes against the piston, moving it in one direction until it activates the proximity switch at the end of the stroke. The hydraulic flow is then sent to the opposite side of the cylinder, and the piston reverses direction until it activates the proximity switch at the opposite end of the stroke.</p>
	<p>The green light on the proximity switch indicates there is power to the switch. The light turns red when the switch is activated. The proximity switches are magnetically activated by the presence of the metallic surface of the piston. When the switch is activated, it sends a signal to the PLC to change the flow of the directional control valve and reverse direction.</p>
	<p>2 The 4-way directional control valve shifts the hydraulics back and forth to the intensifier. A shift valve directs pressurized oil to one end of the hydraulic cylinder and returns fluid to the reservoir from the opposite end, causing the intensifier to stroke. The movement is controlled hydraulically by a pilot valve that is electronically operated by two solenoids, energized by the PLC.</p>
	<p>3 The pressure transducer monitors the output pressure from the attenuator in the high pressure system. If the system pressure is outside the set pressure range, the balancing system automatically adjusts the signal to the proportional valves, increasing or decreasing the demand from the hydraulic pumps.</p>
	<p>4 A temperature switch monitors the temperature of the cutting water from the booster pump. If the temperature exceeds 128° F (53° C), the switch activates an automatic shutdown circuit in the PLC. The temperature switch prevents booster pump overheating due to lack of water, long deadhead conditions or a blocked orifice.</p>

Table 8-1
Sensors and Solenoids



Component	Function
	<p>5 The 30 psi pressure switch, mounted on the inlet manifold at the bulkhead, monitors the inlet cutting water. If the pressure drops below 30 psi (2 bar) the switch activates an automatic shutdown circuit, protecting the booster pump from damage due to insufficient water supply pressure.</p>
	<p>6 The normally closed, inlet water solenoid valve is located at the service bulkhead. When the control power is turned on, the valve opens and allows low pressure cutting water to enter. The solenoid valve functions as a safeguard by closing if a leak is detected anywhere in the system, or if the system is idle for an extended period.</p>
	<p>The function can be disabled so the valve stays open whenever the control power is on.</p> <p>7 When control power is removed, the safety dump valve releases the stored pressure in the intensifiers and high pressure delivery lines. The high pressure dump valve assembly includes a normally open high pressure water valve and a solenoid operated air valve.</p>
	<p>The normally open pneumatic dump valve is held closed by air pressure. When the air supply is interrupted from an emergency stop, the valve opens and allows water to flow through the valve. Pressure is released in the intensifiers and the high pressure water stream exits through the drain.</p>
	<p>8 A 15 psi pressure switch, mounted on the recirculation pump, monitors the oil pressure to the heat exchanger. If the pressure drops below 15 psi (1 bar), the switch activates an automatic shutdown circuit to prevent the hydraulic oil from overheating.</p>

Table 8-1
Sensors and Solenoids

Component	Function
	<p>9 To ensure adequate water pressure and supply to the intensifiers, the discharge pressure is monitored by a 60 psi pressure switch located on the low pressure water manifold. An automatic shutdown occurs if the pressure is below 60 psi (4 bar).</p>
	<p>10 When the desired operating pressure is set, a signal is sent to the proportional pressure control valves, mounted on the hydraulic pumps, to open. The control system increases or decreases the signal as needed to maintain the set operating pressure.</p>
	<p>11 The temperature/low level/warning switch monitors the oil temperature and level in the reservoir. Although the float switch and the temperature switch are combined in a single unit, the two switches function independently.</p> <p>A warning is issued if the operating oil temperature reaches 130° F (55° C). If the temperature exceeds 150° F (65° C), an automatic shutdown occurs.</p> <p>If the hydraulic fluid level falls below specifications, a low oil level shutdown occurs.</p>

8.3 Service and Maintenance Procedures

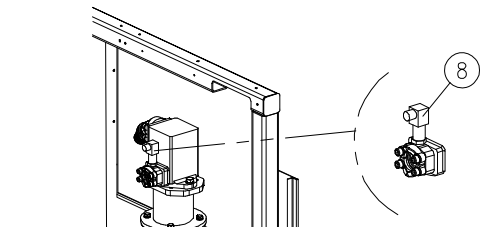
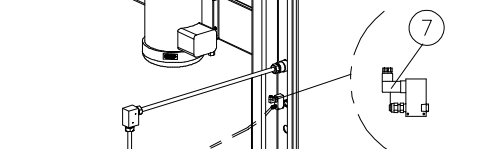
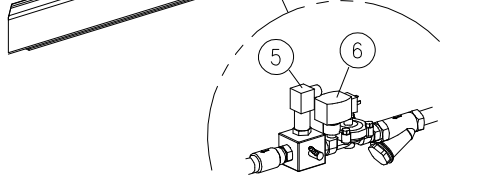
Electrical components require minimal service. The proximity switches on the hydraulic cylinder and the optical relay switches in the controls subassembly may require replacement, and the proportional valve may require cleaning.

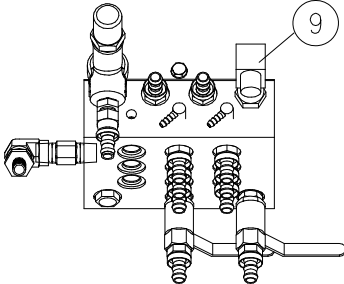
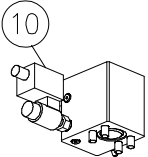
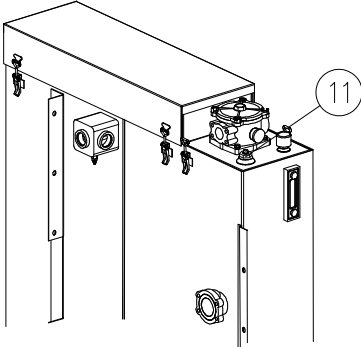
NOTE

Refer to Section 12, Parts List for a complete listing of replacement parts and part numbers.

Proximity Switch Maintenance

A proximity switch has failed and needs to be replaced if the LEDs do not change state, indicating they are not sensing the piston, if an LED flashes continuously, or if the appropriate input is not noted on the PLC processor annunciator light panel in the electrical enclosure.

Figure 8-5: Proximity Switch

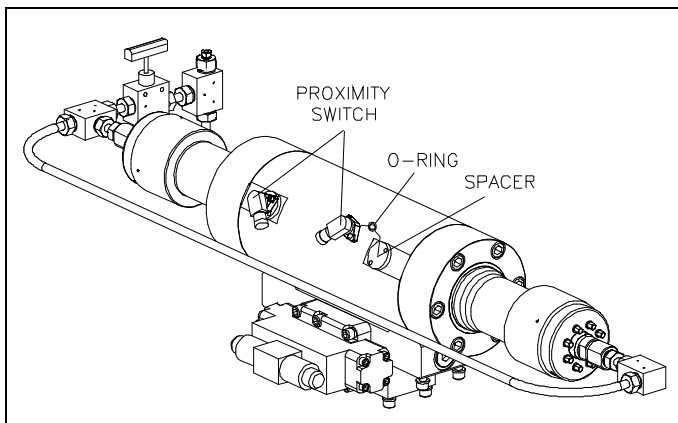

1. Turn the machine off and observe the appropriate Lockout/Tagout procedures.



Severe injury can result if the machine is not properly locked out. Observe electrical Lockout/Tagout procedures before performing maintenance on the system components.

Ensure all pressure is relieved or blocked from the hydraulic and high pressure circuits before performing maintenance.

2. Remove the electrical cable from the failed proximity switch.
3. Remove the two socket head screws, the failed switch and the spacer.

4. Install a new proximity switch by positioning the spacer and the switch. Ensure the o-rings are correctly oriented.
5. Apply JL-M grease to the threads on the screws and tighten to 140-160 in-lbs (16-18 Nm).



Ensure that the proximity switch is properly installed and secured prior to starting the machine. Failure to tighten the two hold down screws on each switch will result in the spray of hydraulic oil.

Optical Relay Maintenance

The optical relays identified in Table 8-2 change the state of the associated solenoid valves. If the relay or the fuse for the relay fails, the state will not change. For example, if the relay controlling the water supply valve fails, the valve will not open and close.

Table 8-2
Optical Relays

Label	Component	Function
4K1	Directional Control Valve, Solenoid A, Intensifier A	Switches the direction of the hydraulic flow
4K2	Directional Control Valve, Solenoid B, Intensifier A	Switches the direction of the hydraulic flow
4K3	Directional Control Valve, Solenoid A, Intensifier B	Switches the direction of the hydraulic flow
4K4	Directional Control Valve, Solenoid B, Intensifier B	Switches the direction of the hydraulic flow
6K1	Directional Control Valve, Solenoid A, Intensifier C (redundant models only)	Switches the direction of the hydraulic flow
6K2	Directional Control Valve, Solenoid B, Intensifier C (redundant models only)	Switches the direction of the hydraulic flow
5K1	Water Supply Valve	Opens and closes the inlet water solenoid valve

Figure 8-6: Optical Relays

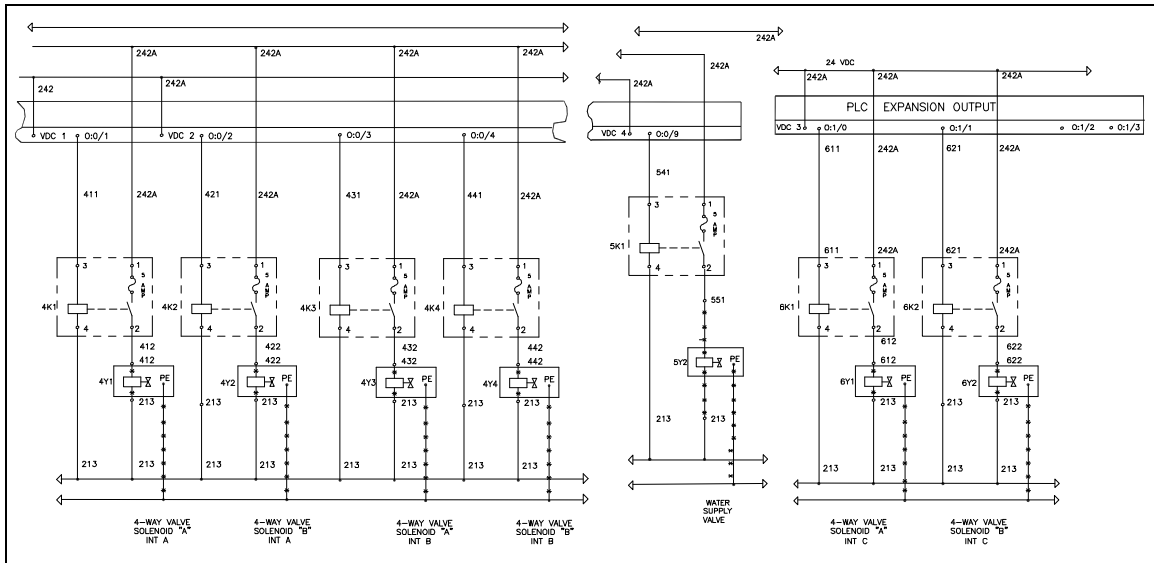

1. Turn the machine off and observe the appropriate Lockout/Tagout procedures.



Severe injury can result if the machine is not properly locked out. Observe electrical Lockout/Tagout procedures before performing maintenance on the system components.

Ensure all pressure is relieved or blocked from the hydraulic and high pressure circuits before performing maintenance.

2. Open the control panel and locate the appropriate optical relay.
3. Remove the screw and the relay.
4. Remove and test the fuse. If the fuse has failed, replace it and re-install the existing optical relay.
5. If the fuse is good, replace the optical relay.



SECTION 9

HIGH PRESSURE WATER SYSTEM

9.1 Overview

The high pressure water system is supported by both the cutting water supply circuit and the hydraulic circuit. Cutting water of sufficient flow and pressure is routed from the cutting water supply circuit to the intensifier where it is pressurized up to 60,000 psi (4,137 bar) and delivered to the cutting head.

The directional control valves in the hydraulic system create the stroking action of each intensifier by sending pressurized hydraulic oil to one side of the hydraulic cylinder or the other. As the flow is sent to one side, hydraulic fluid is returned to the reservoir from the opposite side.

Figure 9-1: High Pressure Water System Circuit

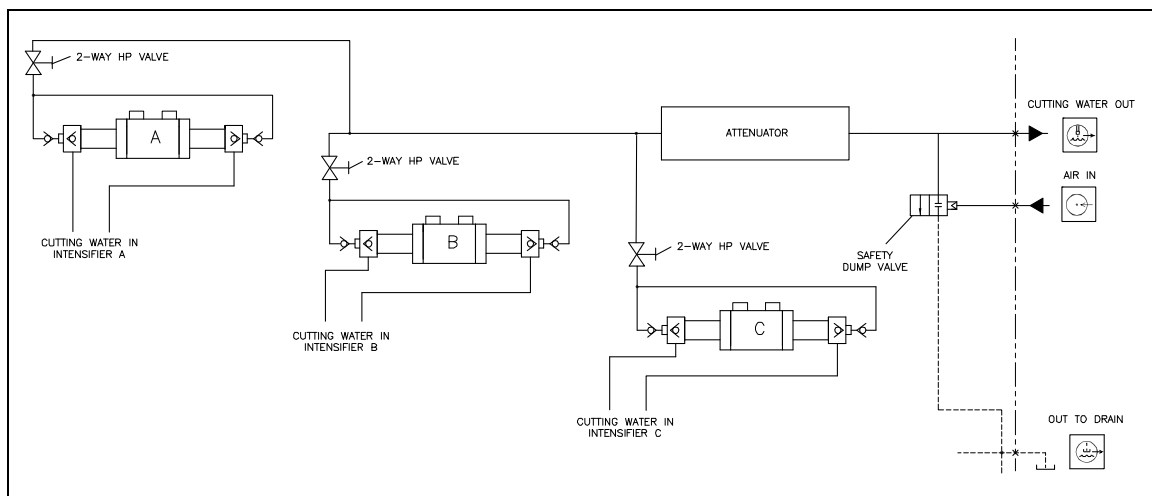

System components include two intensifier assemblies, each consisting of a double-ended hydraulic cylinder and reciprocating piston assembly; high pressure cylinders attached to each end of the hydraulic cylinder incorporate two plungers, sealing heads and hard seal end caps; three liter capacity attenuator, and a safety dump valve. Sophisticated check valves and seal assemblies ensure hydraulic oil, and the low pressure and high pressure water travel in the appropriate direction. Warning and shutdown sensors monitor strategic pressure, temperature and fluid levels to safeguard against component damage.

Redundant models feature a third intensifier assembly that allows operation to continue if one intensifier requires maintenance.

9.2 Operation

The directional control valve sends pressurized hydraulic oil to one side of the hydraulic cylinder. The pressurized oil pushes against the piston, moving it in one direction until it activates the proximity switch at the end of the stroke. The hydraulic flow is then sent to the opposite side of the cylinder, and the piston reverses direction until it activates the proximity switch at the opposite end of the stroke.

Figure 9-2: High Pressure Water System

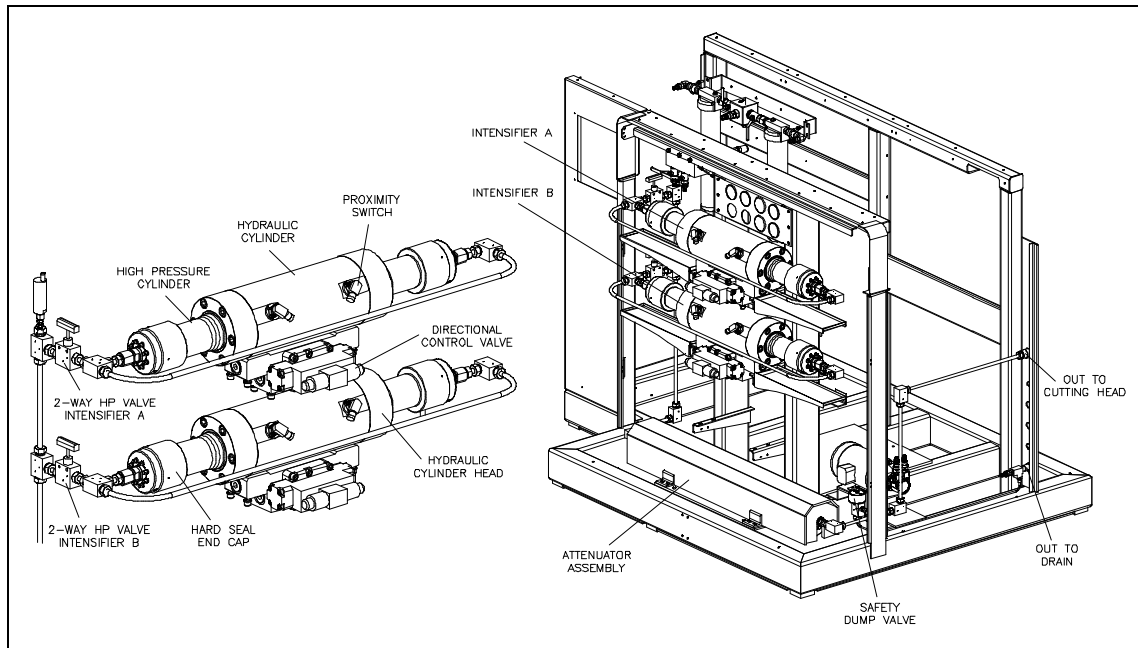

The green light on the proximity switch indicates there is power to the switch. The red light illuminates when the switch is activated. The proximity switches are magnetically activated by the presence of the metallic surface of the piston. When the switch is activated, it sends a signal to the PLC to change the flow of the directional control valve and reverse direction.

The intensifier is a reciprocating pump. As the piston and plungers move from one side to the other, high pressure water exits one side of the intensifier as low pressure water fills the opposite side.

As the pressurized oil pushes the piston in one direction, the plunger on that end extends and pushes against the water in the high pressure cylinder, increasing the pressure up to 60,000 psi (4,137 bar). When the piston reverses direction, the plunger retracts and the plunger in the opposite cylinder extends to deliver the high pressure water.

Low pressure water is routed through the inlet water ports on the hard seal end caps to the inlet passages in the sealing heads. When the plunger retracts, the inlet check valve opens to allow water to fill the high pressure cylinder. When the plunger extends to create high pressure water, the inlet valve closes to seal the inlet passage and the discharge check valve opens to allow the high pressure water to exit the cylinder. As the plunger retracts, the discharge check valve closes.

Figure 9-3: High Pressure Cylinder

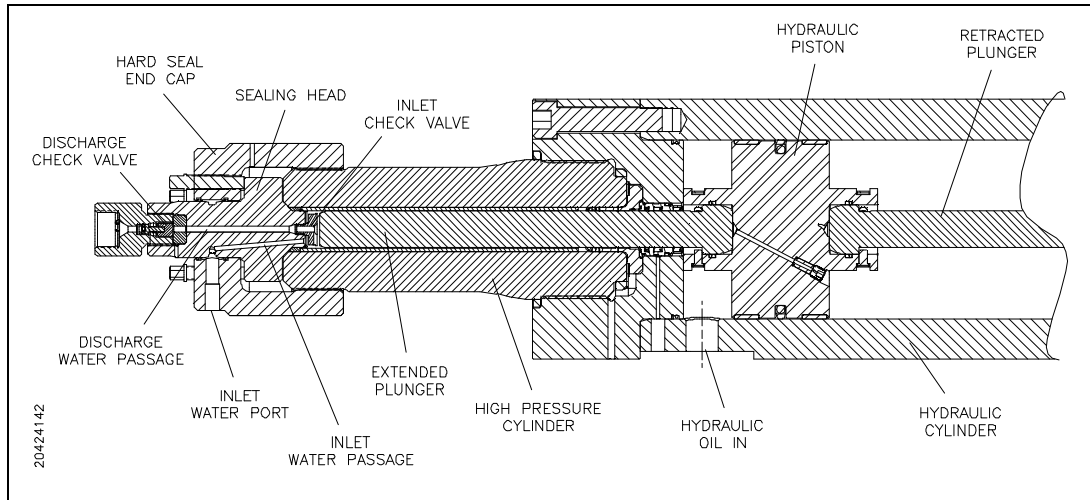

The high pressure water is then routed to the attenuator. The attenuator acts as a shock absorber to dampen pressure fluctuations and ensure a steady and consistent supply of water. From the attenuator, the high pressure water exits to the cutting head.

The safety dump valve releases the stored pressure in the intensifier and high pressure delivery lines. The high pressure dump valve assembly includes a normally open high pressure water valve and an electrically controlled air valve.

The normally open pneumatic dump valve is held closed by air pressure. When the air supply is interrupted and exhausted from an emergency stop, the valve opens and allows water to flow through the valve. Pressure is released in the intensifier and the high pressure water stream exits through the drain.

9.3 Operating Configuration

Normal operation utilizes both intensifier assemblies A and B. Partial power operation utilizes only one intensifier, either A or B. Partial power allows operation to continue if one intensifier requires maintenance. It also serves as a troubleshooting tool in determining which intensifier is the source of a problem.

NOTE

Partial power operation reduces the overall capacity of the machine. Refer to Section 4, Operation, for additional information regarding reduced capacity.

Figure 9-4: Low and High Pressure Water Valves

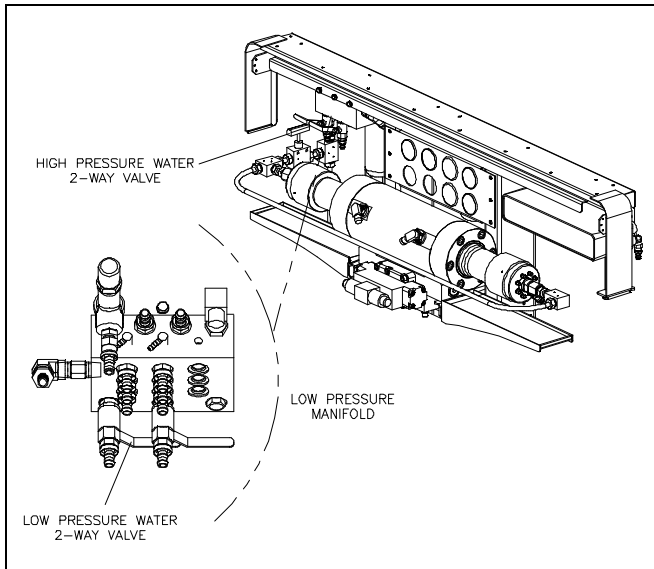

The active intensifier(s) are selected from the Valve Position Screen on the control panel. The low pressure water valves, located on the low pressure manifold, are opened or closed to direct the inlet water flow. The high pressure water valves are opened or closed to direct the cutting water flow. The Valve Position Screen displays the correct position for the low and high pressure water valves for the selected intensifier configuration as illustrated in Table 9-1. For example, when operating both intensifiers A and B, low pressure valves A and B are open and high pressure valves A and B are open. When operating intensifier A only, the low and high pressure valves for intensifier B are closed.

Table 9-1
Valve Positions

	Low Pressure Valve		High Pressure Valve	
	A	B	A	B
Intensifiers A & B	O	O	O	O
Intensifier A	O	X	O	X
Intensifier B	X	O	X	O

Note: O = Open, X = Closed

The following example describes the procedure for operating with intensifiers A and B.

1. Press the STOP button.
2. On the Run Screen, press the INT button to display the Valve Position Screen.

3. On the Valve Position Screen, press the INT button to select intensifiers A and B. The screen will display the correct valve positions for the selected intensifier configuration.

Figure 9-5: Valve Position Screen

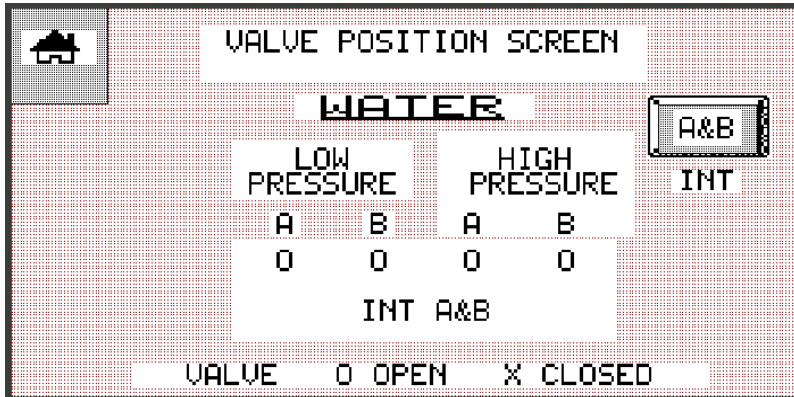

4. On the low pressure water manifold, open the 2-way, low pressure valves for intensifiers A and B.
5. Open the 2-way, high pressure valves for intensifiers A and B.
6. Start the machine at a low pressure and inspect the hydraulic, high pressure fittings, valves and hoses for leaks.

Redundant Models

In addition to the low and high pressure water valves, redundant models utilize 3-way valves, located on the hydraulic manifolds, to direct the oil flow from the pumps to the intensifiers. Hydraulic pump 1 supplies hydraulic oil to intensifier A or C, and hydraulic pump 2 supplies intensifier B or C.

Figure 9-6: Redundant Valves

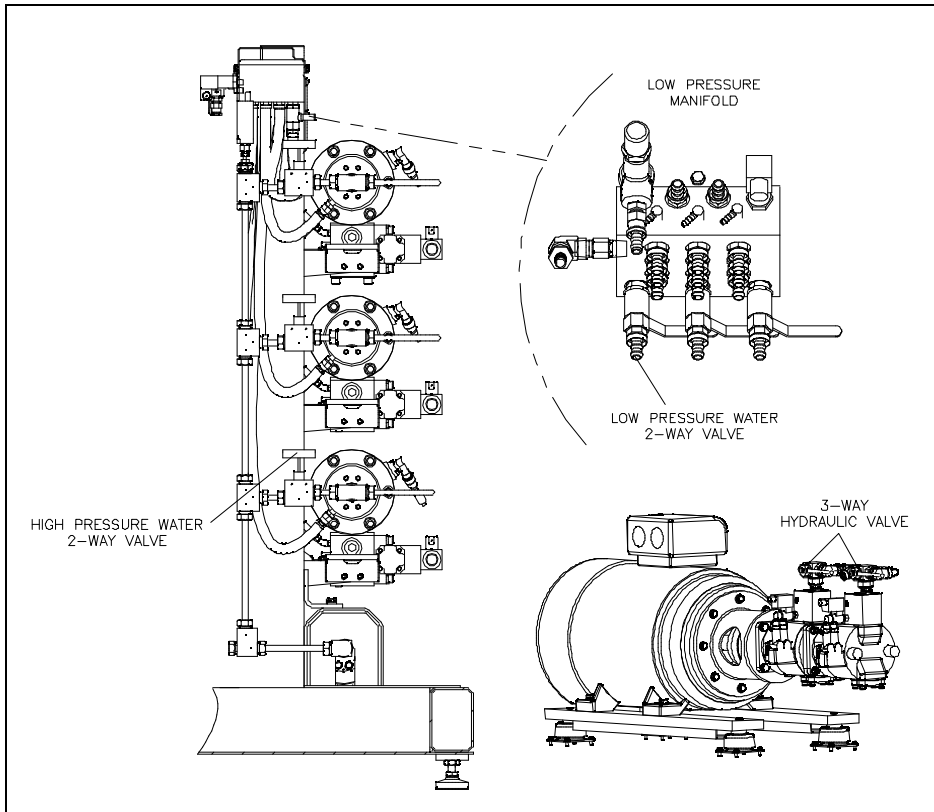

The Redundant Valve Position Screen displays the correct position for the low and high pressure water valves, and the 3-way hydraulic valves as illustrated in Table 9-2.

Table 9-2
Redundant Valve Positions

	Hydraulic Valve		Low Pressure Valve			High Pressure Valve		
	1	2	A	B	C	A	B	C
Intensifiers A & B	A	B	O	O	X	O	O	X
Intensifiers A & C	A	C	O	X	O	O	X	O
Intensifiers B & C	C	B	X	O	O	X	O	O
Intensifier A	A	B/C	O	X	X	O	X	X
Intensifier B	A/C	B	X	O	X	X	O	X
Intensifier C	C	B	X	X	O	X	X	O

Note: O = Open, X = Closed

The following example describes the procedure for operating with intensifiers A and C.

1. Press the STOP button.
2. On the Run Screen, press the INT button to display the Valve Position Screen.
3. On the Valve Position Screen, press the INT button to select intensifiers A and C. The screen will display the correct valve positions for the selected intensifier configuration.

Figure 9-7: Redundant Valve Position Screen

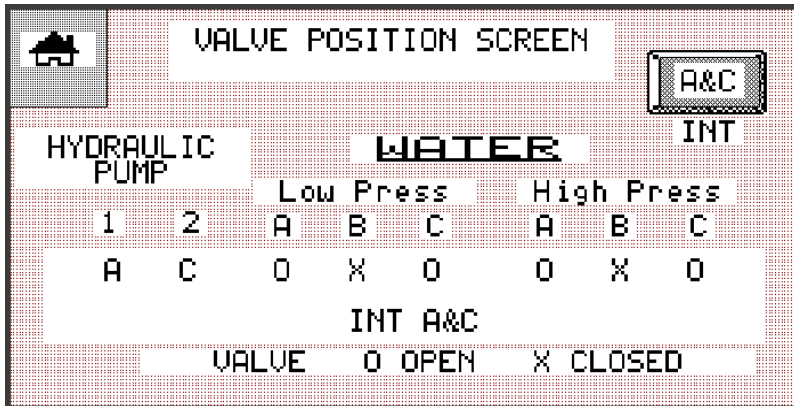

4. Remove the side cover to gain access to the 3-way valves on the hydraulic pumps. Set the valve on hydraulic pump 1 to position A, set the valve on pump 2 to position C. Replace the side cover.
5. On the low pressure water manifold, open the 2-way, low pressure valves for intensifiers A and C, and close the valve for intensifier B.
6. Open the 2-way, high pressure valves for intensifiers A and C, and close the valve for intensifier B.
7. Start the machine at a low pressure and inspect the hydraulic, high pressure fittings, valves and hoses for leaks.



If one intensifier requires maintenance, redundant models allow full operation to continue by removing the effected intensifier from the active configuration. However, maintenance **must not** be performed while the machine is in operation.

Maintenance **must never** be performed on any high pressure components while the machine is operating. All pressure must be relieved or blocked from the hydraulic and high pressure circuits and the electrical panel must be locked out before performing maintenance.

9.4 System Components

The following figures illustrate the individual components in each intensifier assembly.

Figure 9-8: High Pressure Cylinder Assembly

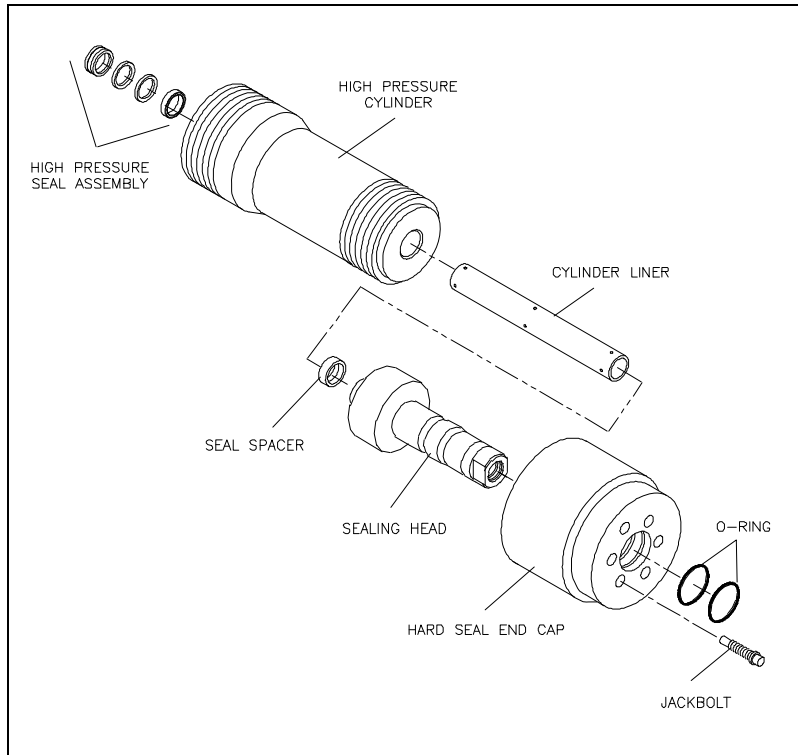

Figure 9-9: Hydraulic Cylinder Assembly

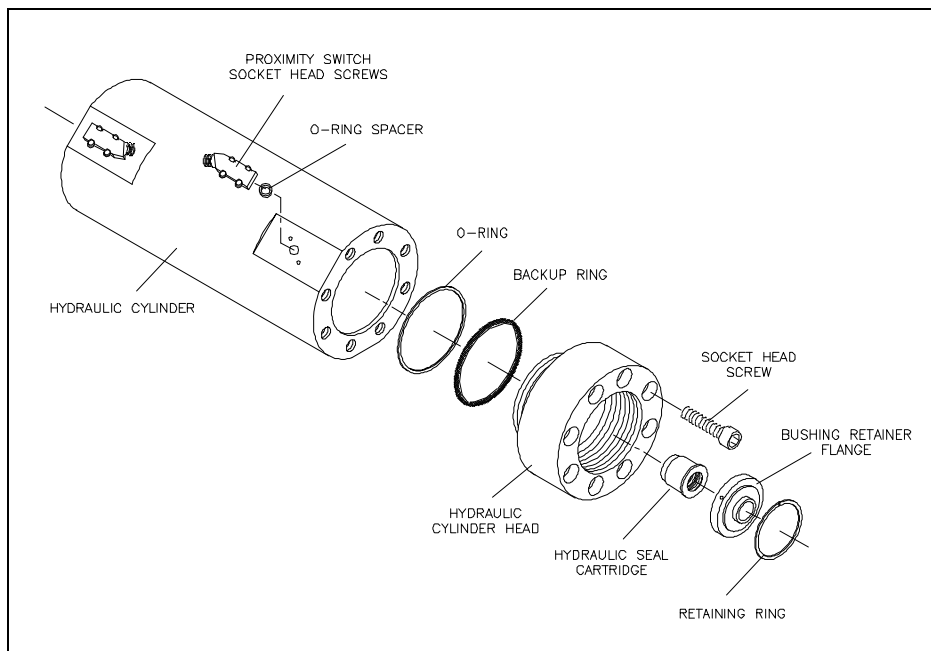
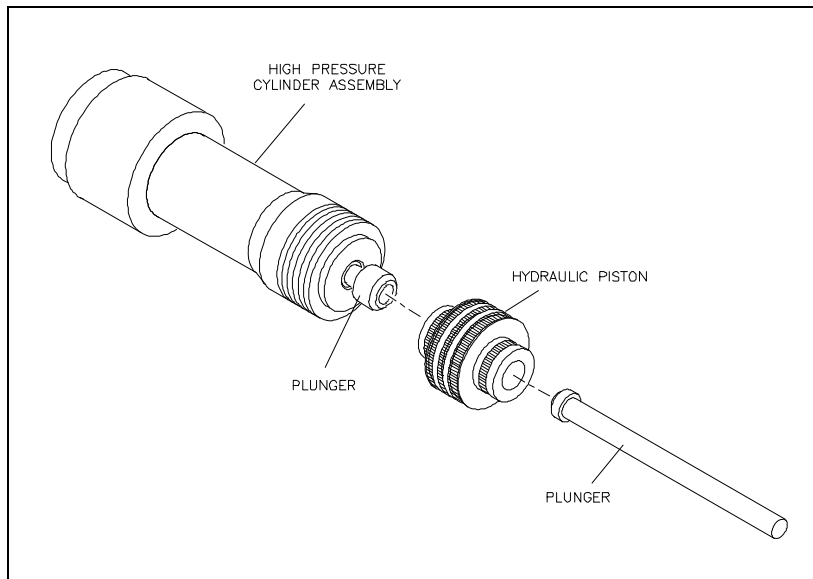

Figure 9-10: Hydraulic Piston

9.5 Service and Maintenance Overview

Never perform any type of maintenance on the high pressure water system while it is pressurized. Always turn the power off and bleed the high pressure water before servicing. Pressing the emergency stop button turns the control power off to the intensifier, and bleeds high pressure water through the dump valve.

Improper assembly can lead to the premature failure of components. Maintenance procedures must be followed carefully; components must be properly cleaned prior to assembly and tightened to the correct torque specifications.

Some high pressure components are not serviceable at the customer level, others require precise refinishing. KMT Waterjet Systems offers maintenance and refinishing services for these components.

NOTE

Refer to Section 12, Parts List for a complete listing of replacement parts and part numbers.

Torque Specifications

Table 9-3, Torque Specifications, details the torque specifications and tightening sequences for the high pressure components and connections.

**Table 9-3
Torque Specifications
High Pressure Water System**

Hard Seal End Cap	
Jackbolts	8 (7/16") each
1st Stage	Hand Tight
2nd Stage	20 ft-lbs (27 Nm)* Crossing Pattern
3rd Stage	32-35 ft-lbs (43-47 Nm) Crossing Pattern
4th Stage	32-35 ft-lbs (43-47 Nm) Clockwise Pattern From Bolt 1
Socket Wrench Size	3/8 inch

8-Bolt Crossing Pattern

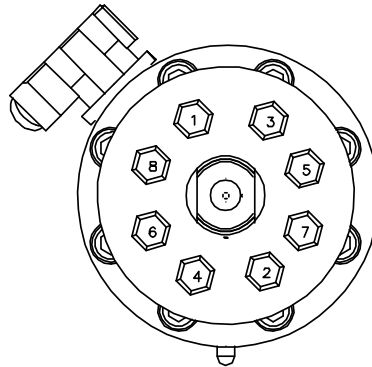

* **Note:** Crossing Pattern: 1, 2, 3, 4, 5, 6, 7, 8.

** **Note:** A maximum torque of 38 ft-lbs (51 Nm) is etched on the hard seal end cap. This represents the **maximum** allowable torque, not the recommended torque.

Hydraulic Cylinder Head	
Socket Head Screws	6 (3/4") each
Torque	170-175 ft-lbs (230-237 Nm)
Hex Key	5/8 inch



Table 9-3
Torque Specifications
High Pressure Water System

Proximity Switch	
Socket Head Screws	2 (1/4") each
Torque	140-160 in-lbs (16-18 Nm)
Hex Key	3/16 inch
Sealing Head	
Discharge Gland Nut	200 ft-lbs (271 Nm)
Poppet Retainer	25-30 in-lbs (2.8-3.4 Nm)
Pneumatic Control Valve	
3/8" HP Inlet Gland Nut	50 ft-lbs (68 Nm)
1/4" Outlet to Drain	25 ft-lbs (34 Nm)
Pneumatic Actuator	5 ft-lbs (7 Nm)
9/16"-1/4" HP Bushing	110 ft-lbs (149 Nm)
High Pressure Fittings	
1/4" HP Gland Nut	25 ft-lbs (34 Nm)
3/8" HP Gland Nut	50 ft-lbs (68 Nm)
9/16" HP Gland Nut	110 ft-lbs (149 Nm)
3/4" HP Gland Nut	120 ft-lbs (163 Nm)

Specialized Maintenance Tools

KMT Waterjet has designed tools to facilitate the removal and installation of specialized system components. These tools are illustrated in Figure 9-8, Specialized Maintenance Tools, and part numbers are provided in Table 9-3.

Figure 9-11: Specialized Maintenance Tools

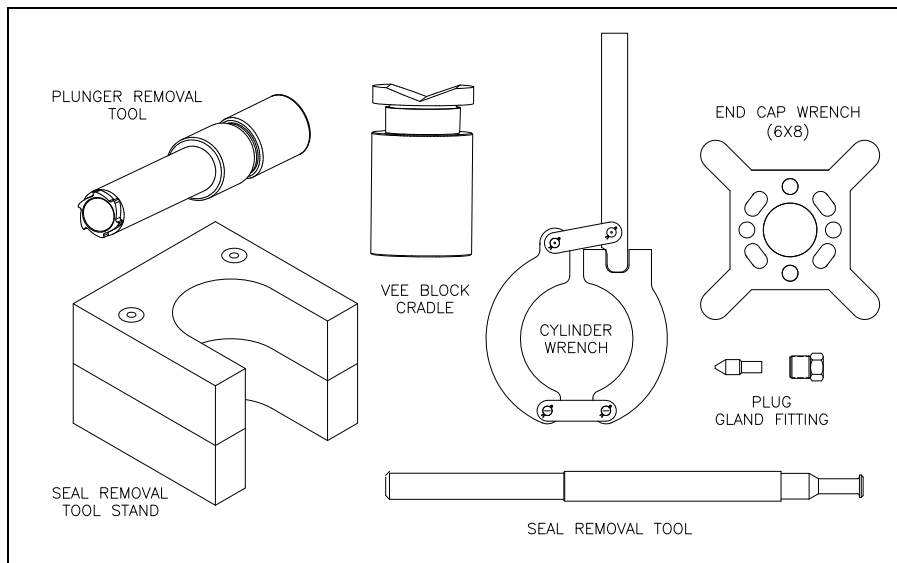

**Table 9-4
Specialized Maintenance Tools
High Pressure Water System**

	Part Number
Plunger Removal Tool	20477469
Vee Block Cradle	20484961
Plug	10078772 (9/16")
Gland Fitting	10078608 (9/16")
Seal Removal Tool	05146618
End Cap Wrench	80079247 (8x)
Cylinder Wrench	05066139
Seal Removal Tool Stand	80078330

9.6 High and Low Pressure Water Connections

Before performing any maintenance on the high pressure components, it is necessary to remove the high and low pressure water piping from the end of the intensifier being serviced. The following procedure should be used to remove and install the piping and connections.

1. Turn the machine off and observe the appropriate Lockout/Tagout procedures.



Severe injury can result if the machine is not properly locked out. Observe electrical Lockout/Tagout procedures before performing maintenance on the high pressure system components.

Ensure all pressure is relieved or blocked from the hydraulic and high pressure circuits before performing maintenance.

2. Turn the cutting water supply off at the bulkhead.
3. Turn the low pressure, 2-way valve off for the intensifier being serviced.
4. Turn the high pressure, 2-way valve off for the intensifier being serviced.
5. Loosen and/or remove the high pressure connections illustrated in Figure 9-12 and detailed below. Move the fittings and tubing to clear the work area.

Figure 9-12: High Pressure Piping and Connections

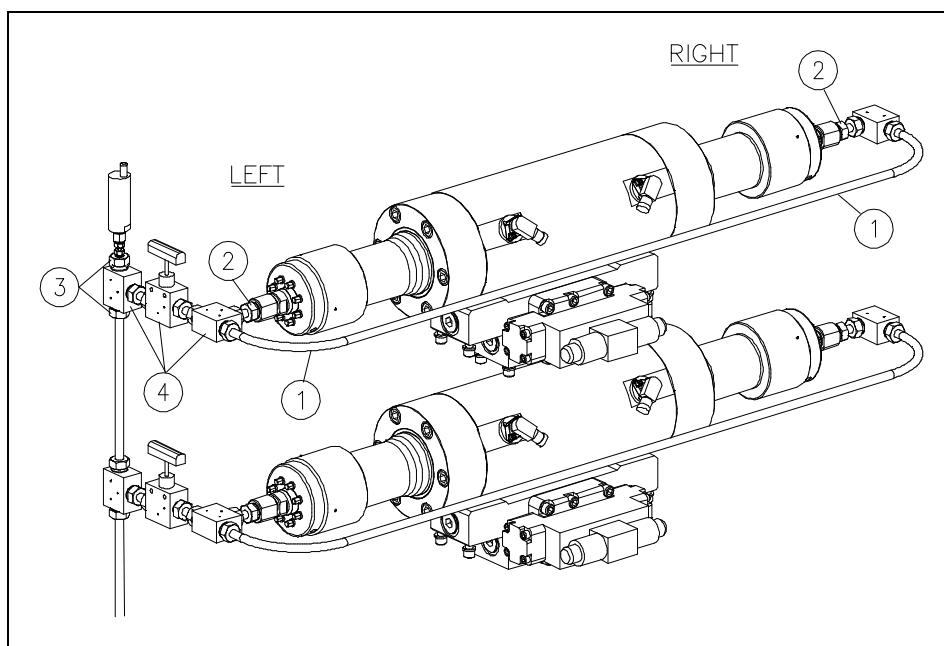

To service the right end of the intensifier:

1. Remove the 9/16-inch high pressure tube with the ferrules and flexible conduit.
2. Loosen the 9/16-inch high pressure gland nut and remove the gland with the high pressure tube and elbow.

To service the left end of the intensifier:

1. Remove the 9/16-inch high pressure tube with the ferrules and flexible conduit.
2. Loosen the 9/16-inch high pressure gland nut.
3. Loosen the 9/16-inch high pressure glands on both ends of the high pressure tee.
4. Rotate the tees and 2-way valve to access the high pressure cylinder assembly.
6. Disconnect the low pressure piping connected to the inlet water port on end of the intensifier being serviced.

Figure 9-13: Low Pressure Piping

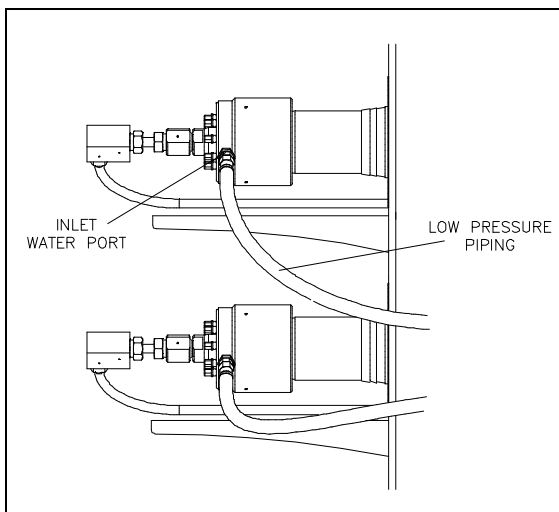

7. When the required maintenance has been completed and the components reassembled, connect the low pressure water piping to the inlet water port.
8. Apply Pure Goop to the threads on the high pressure gland fittings. Before installing the high pressure fittings, ensure proper collar position, 1-1/2 to 2-1/2 threads should be exposed. Install and tighten the fittings to the torque specifications in Table 9-3.
9. Turn the low pressure and high pressure, 2-way water valves on.
10. Turn the cutting water supply on at the bulkhead and check for low pressure leaks.
11. Remove the cutting orifice and start the machine. Operate at a low pressure to flush the high pressure passages.

12. Install the orifice and operate at a high pressure to check for leaks.

9.7 High Pressure Cylinder Assembly

KMT Waterjet recommends removing the high pressure cylinder, sealing head and end cap as an assembly for servicing the plunger, high pressure seals, hydraulic piston and seal cartridge. Removing the jackbolts in the hard seal end cap is not recommended except to service the inlet check valve and cone seat on the sealing head.

High Pressure Cylinder Assembly Removal

Prior to removing electrical power or any high or low pressure piping, start the machine from the Maintenance Screen on the control panel. The machine will start in maintenance mode; the dump valve will open and relieve the high pressure in the system.

Press the RIGHT or LEFT arrow to extend the plunger on the end to be serviced. The plunger will extend in the selected direction, allowing full exposure when the unit is disassembled.

1. Turn the machine off and observe the appropriate Lockout/Tagout procedures.



WARNING

Severe injury can result if the machine is not properly locked out. Observe electrical Lockout/Tagout procedures before proceeding.

Ensure all pressure is relieved or blocked from the hydraulic and high pressure circuits before proceeding.

2. Disconnect the high and low pressure water connections, following the procedure, High and Low Pressure Water Connections.

NOTE

Prior to removal, verify that the alignment marks on the high pressure cylinder and on the hydraulic cylinder head are aligned. If not, check the condition of the retaining ring and the bushing retainer flange after the cylinder assembly is removed.



CAUTION

Due to the weight of the cylinder assembly, adequate support must be provided to prevent damage to the plunger or seals during removal and installation. See Figure 9-11, Specialized Maintenance Tools for tools available to support the high pressure assembly for this procedure.

3. Position the vee block cradle tool on the drip pan under the cylinder assembly. Unthread and remove the assembly from the hydraulic cylinder head and plunger. The assembly can be rotated with the cylinder wrench or by hand. Move the assembly to a workbench for service. **Do not** perform any type of maintenance on the drip pan.



Do not perform any type of maintenance on the drip pan. The drip pan should only be used to support the high pressure cylinder assembly during removal.

Figure 9-14: High Pressure Cylinder Assembly Removal and Installation

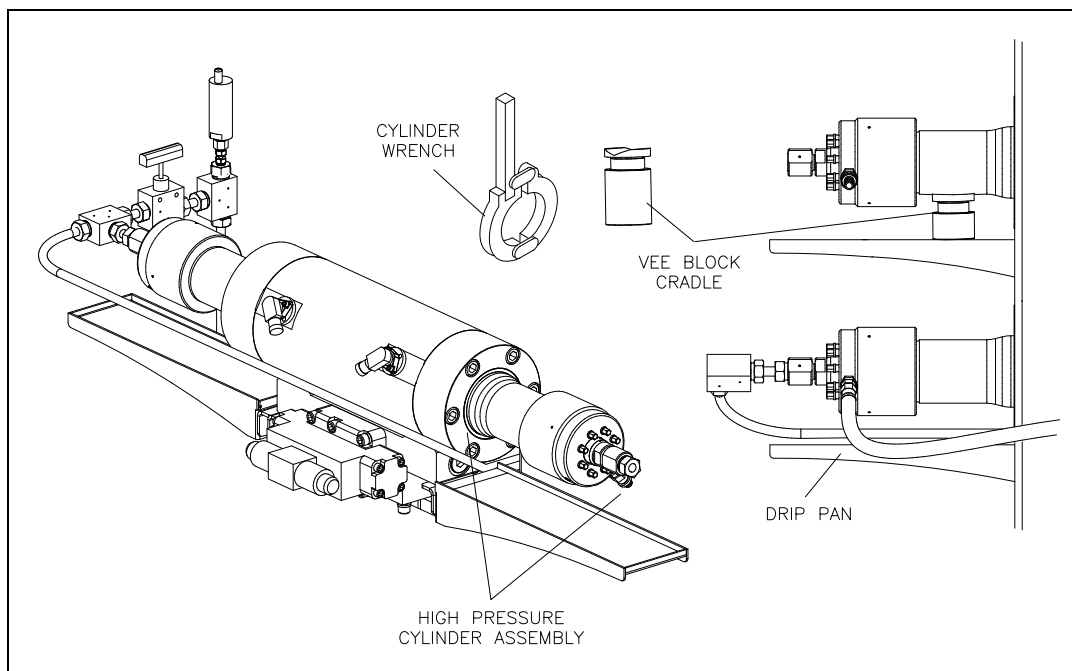

NOTE

If thread or metal surface galling is detected during removal, galled surfaces and threads must be filed, sanded and lubricated prior to reassembly. See the procedure, High Pressure Cylinder Maintenance.

High Pressure Cylinder Assembly Installation

1. Verify that the high pressure cylinder threads and alignment surfaces are adequately cleaned and lubricated with Pure Goop, and that the threads have been sanded and dressed if galling was encountered during removal.

2. Verify that the high pressure seal assembly, packing follower and cylinder liner are correctly installed. Align the cylinder assembly with the plunger and the hydraulic cylinder head, using the cradle tool to support the weight. Carefully push and lift the assembly into position until the threads are ready to engage.
3. Thread the cylinder assembly into the hydraulic cylinder head.

NOTE

If galling occurs during threading, remove the high pressure cylinder assembly and inspect the mating surfaces and threads. Repair surfaces, thoroughly clean, lubricate and thread the cylinder assembly into the hydraulic cylinder head.

NOTE

An alignment mark is located on the hydraulic cylinder head under the KMT logo. To ensure the high pressure cylinder is properly tightened and fully seated in the hydraulic cylinder head, it is recommended that a corresponding mark be placed on the high pressure cylinder after installation. Periodically inspect the cylinder for movement. If movement is detected, retighten the assembly.

4. Install the high and low pressure water connections, following the procedure, High and Low Pressure Water Connections.
5. Start the machine at a low pressure to flush air from the high pressure components and to check for obvious leaks. After 5-10 strokes, switch to a high pressure operation and check for leaks.

If leaks are detected, turn the machine off and remedy the problem. When the problem has been remedied, repeat the startup procedure, moving from a low to a high pressure soon after the intensifier starts pumping water. There is no further need to flush air from the system.

High Pressure Cylinder Maintenance

The plunger seal area in the high pressure cylinder bore should be inspected and cleaned each time the high pressure seal assembly is replaced.

1. Clean the sealing area on the inside diameter of the high pressure cylinder and inspect the bore for rings, scratches, pits, residue or other potential leak paths.

Seal material or residue can build up, forming a ring. Running a fingernail across the buildup will cause it to appear as a surface flaw. Grooves or ridges are typically seal debris buildup rather than marks on the inside diameter wall of the cylinder.

2. Polish the inside diameter of the cylinder where the seal will locate with 600-grit wet/dry sandpaper. Hold the sandpaper on the end of your finger and move in a cylindrical wiping motion. Polish in a circumferential motion only. Do not polish or drag the sandpaper along the length of the cylinder.
3. Clean the residue from the inside diameter of the cylinder and re-inspect for surface defects.

9.8 Hard Seal End Caps

KMT Waterjet recommends loosening the jackbolts and removing the hard seal end caps (HSEC) only to service the inlet check valve and the cone seat on the sealing head.

Hard Seal End Cap Removal

1. Turn the machine off and observe the appropriate Lockout/Tagout procedures.



Severe injury can result if the machine is not properly locked out. Observe electrical Lockout/Tagout procedures before proceeding.

Ensure all pressure is relieved or blocked from the hydraulic and high pressure circuits before proceeding.

2. Disconnect the high and low pressure water connections, following the procedure, High and Low Pressure Water Connections.
3. Loosen the jackbolts in the hard seal end cap.
4. Unscrew and remove the HSEC from the high pressure cylinder.
5. Remove the sealing head. The sealing head may be removed with the HSEC or after the end cap has been removed.
6. Verify the removal of the white plastic seal spacer used to position the sealing head relative to the high pressure cylinder. The spacer may come out with the sealing head. If not, the spacer must be removed from the cylinder bore prior to reinstalling the sealing head to avoid pushing it farther into the bore.

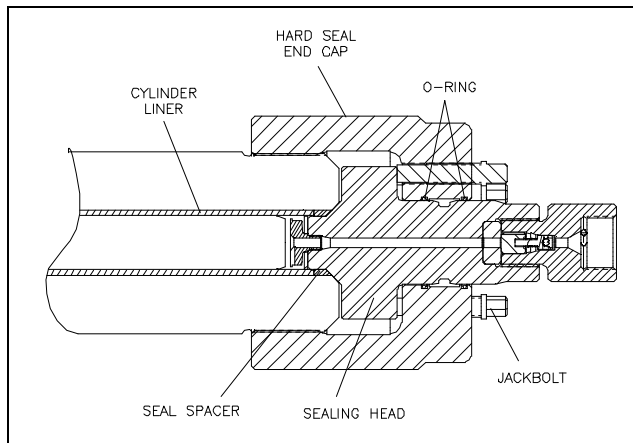
Figure 9-15: Hard Seal End Cap

Hard Seal End Cap Installation

1. Apply FML-2 grease to the two o-rings and verify they are properly installed in the inside diameter grooves of the HSEC. Check the high pressure cylinder bore to verify the presence of the cylinder liner and to ensure the seal spacer has been removed from the bore.
2. Apply FML-2 grease to the inside and outside diameter of the spacer and position the spacer on the inlet end of the sealing head.
3. Place the sealing head and the seal spacer in the end of the high pressure cylinder and press the sealing head into the cylinder by hand.
4. Apply JL-M grease to the threads on the jackbolts. Ensure the jackbolts are slightly less than flush with the inner face of the end cap.
5. Slide the end cap over the sealing head until it makes contact with the high pressure cylinder. Fully engage the threads on the end cap with the high pressure cylinder. The cone seal on the sealing head should be in contact with the cylinder.
6. Unscrew the HSEC until the inlet water port is properly oriented to facilitate the low pressure water connection. **Do not** unscrew the HSEC more than one full turn.
7. Hand-tighten the jackbolts until they make contact with the sealing head.
8. Tighten the jackbolts following the tightening sequence and torque specifications in Table 9-3.
9. Install the high and low pressure water connections.
10. Start the machine at a low pressure to flush air from the high pressure components and to check for obvious leaks. After 5-10 strokes, switch to a high pressure operation and check for leaks.

If leaks are detected, turn the machine off and remedy the problem. When the problem has been remedied, repeat the startup procedure.

9.9 Sealing Head

The sealing head is sealed to the outboard end of the high pressure cylinder by a 45-degree metal-to-metal compression seal. The pre-loading jackbolts in the hard seal end cap hold the sealing head against the end of the cylinder.

The inlet and discharge check valves in the sealing head ensure the low pressure and high pressure water only travels in the appropriate direction.

Figure 9-16: Sealing Head

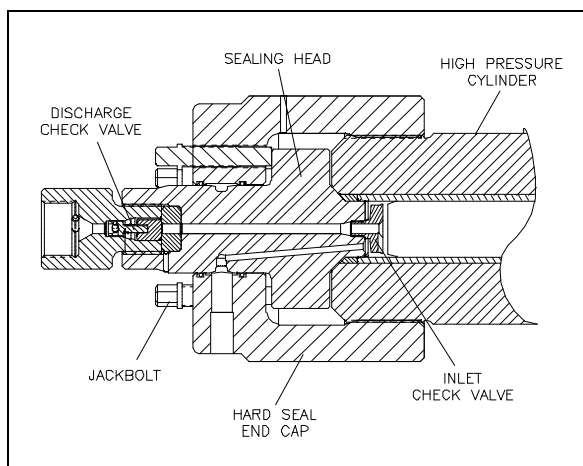

High Pressure Discharge Check Valve

The high pressure discharge check valves should be serviced on a regular, preventive maintenance schedule. Service is recommended every 1,500 hours. The discharge check valve can be serviced with the sealing head either installed or removed from the high pressure cylinder.

1. Turn the machine off and observe the appropriate Lockout/Tagout procedures.



Severe injury can result if the machine is not properly locked out. Observe electrical Lockout/Tagout procedures before proceeding.

Ensure all pressure is relieved or blocked from the hydraulic and high pressure circuits before proceeding.

2. Disconnect the high pressure water connections, following the procedure, High and Low Pressure Water Connections.

3. Use two wrenches to remove the gland nut. The poppet pin, spring and poppet check valve will normally remain in the gland nut when it is removed. Remove the components from the gland nut.

Figure 9-17: High Pressure Discharge Check Valve

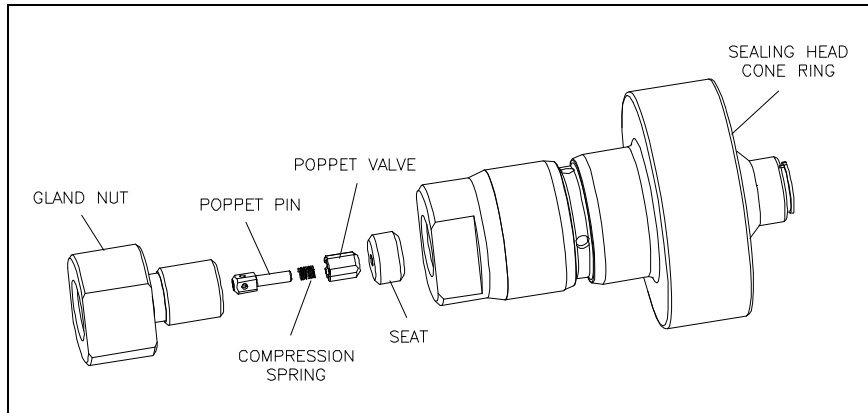

4. Use a magnet to remove the seat from the sealing head.
5. Inspect the poppet pin for wear and replace the pin if worn.
6. Inspect both faces of the seat for damage or cracking. A cracked or damaged seat must be replaced. The seat can be installed with either face toward the poppet valve. If one face is worn, but the opposite is not, the seat can be reversed, placing the new surface toward the poppet valve. A slight burr at the hole edge identifies the used side of the seat. If both faces are worn, the seat must be replaced.

NOTE

The seat, spring and poppet valve should be replaced as a set. If one component requires replacement, replace all components.

7. Apply a thin film of Pure Goop to the face of the seat opposite the poppet check valve and install the seat into the sealing head. If the existing seat is reused, install the seat with the new surface facing the poppet valve.
8. Install the poppet pin and the spring, with the larger end of the spring facing the poppet valve, and then install the poppet valve into the gland nut.
9. Apply Pure Goop to the sealing face and the threads on the gland nut and thread the gland nut into the sealing head. Hand-tighten until there is a 0.20 inch (5 mm) gap between the gland nut and the sealing head. **No threads should show.** If the gap exceeds 0.20 inch (5 mm), the poppet or seat has slipped out of position. The parts must be removed, inspected and re-assembled.
10. Use a crowfoot/torque wrench combination and tighten the gland nut to the torque specifications in Table 9-3.

Low Pressure Inlet Check Valve

The inlet check valves should be serviced on a regular, preventive maintenance schedule. Service is recommended every 1,500 hours. The hard seal end cap must be removed to service the inlet check valve.

Follow the procedure, Hard Seal End Cap Removal. When the end cap has been removed, proceed with Step 1 below.

Figure 9-18: Low Pressure Inlet Check Valve

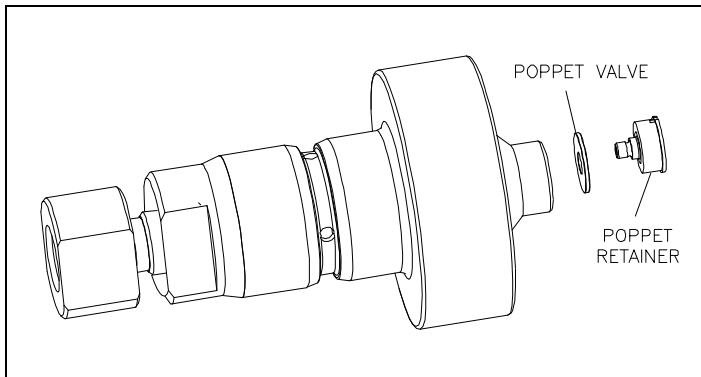

1. Use a 1/2-inch flat blade screwdriver to remove the poppet retainer from the sealing head.
2. Inspect the sealing head for scratches or wear on the cone ring contact surface, and on the inlet poppet valve contact surface. If defects are detected, the surfaces must be refinished. See the procedure, Sealing Head Maintenance.
3. Inspect both faces on the inlet poppet valve. The poppet valve can be installed with either face toward the sealing head. If one face is worn, but the opposite is not, the poppet can be reversed, placing the best surface toward the sealing head. If both faces are worn, the poppet valve must be replaced.
4. Spray Loctite 7649 on the threads of the poppet retainer and allow to dry. Assemble the inlet poppet valve on the poppet retainer. Apply a small amount of Loctite 242 to the poppet retainer threads only. **Do not** get any Loctite on the poppet or any other surfaces on the inlet check valve.
5. Use the flat blade screwdriver to tighten the poppet retainer. Tighten the poppet retainer to the torque specifications in Table 9-3.
6. Inspect the assembled unit to ensure the poppet moves freely and the poppet retainer is seated against the sealing head.

Sealing Head Maintenance

The sealing head should be inspected for scratches, excessive sealing damage or erosion marking on the cone ring contact surface, and on the inlet poppet valve contact surface. If defects are detected, the surfaces must be refinished. The sealing head can be returned to KMT Waterjet for refinishing.

1. Clean the 45-degree surface on the cone ring with 600-grit wet/dry sandpaper, using a radial motion. It will not be possible to fully remove the main sealing marks.
2. Inspect the inlet poppet valve sealing surface for pits, scratches or jetting erosion. If necessary, refinish the surface.

Place a piece of 1/4-1/2-inch thick plate glass, not window glass, on a sturdy table to provide an absolutely flat surface. Place a piece of 400-grit wet/dry sandpaper on the glass. Use even, deliberate strokes, rotating the sealing head approximately 10-15 degrees after each stroke. Polish the sealing head until it is flat and smooth. Be careful not to cause additional damage by tilting or tipping the part while polishing.

3. When the sealing head is flat and smooth, perform a final polish with 600-grit wet/dry sandpaper.

9.10 High Pressure Seal Assembly

The following procedure should be used to replace the high pressure seal assembly.

Prior to removing electrical power or any high or low pressure piping, start the machine from the Maintenance Screen on the control panel. The machine will start in maintenance mode; the dump valve will open and relieve the high pressure in the system.

Press the RIGHT or LEFT arrow to extend the plunger on the end to be serviced. The plunger will extend in the selected direction, allowing full exposure when the unit is disassembled.

1. Turn the machine off and observe the appropriate Lockout/Tagout procedures.



Severe injury can result if the machine is not properly locked out. Observe electrical Lockout/Tagout procedures before proceeding.

Ensure all pressure is relieved or blocked from the hydraulic and high pressure circuits before proceeding.

2. Disconnect the high and low pressure water connections, following the procedure, High and Low Pressure Water Connections.
3. Remove the high pressure cylinder assembly, following the procedure, High Pressure Cylinder Assembly Removal.

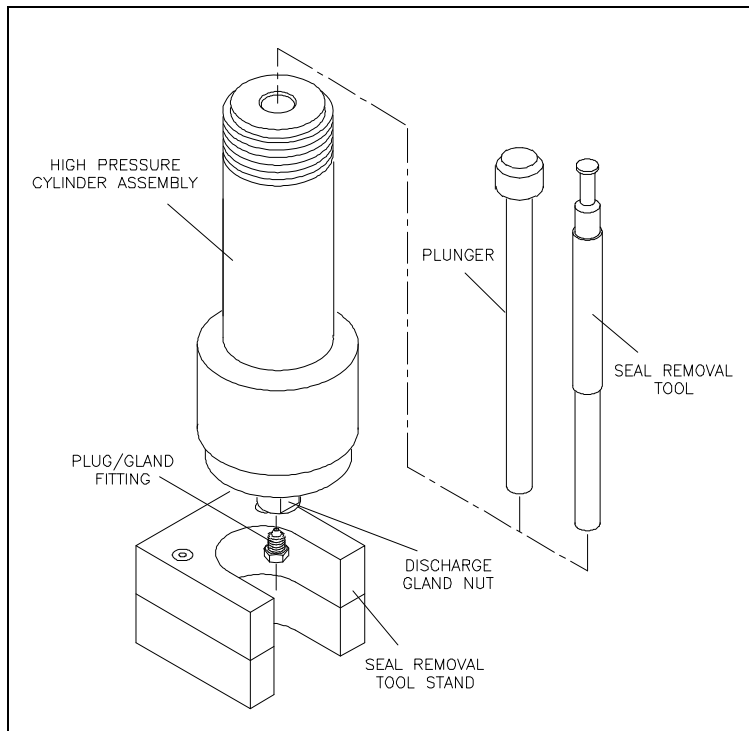
Figure 9-19: High Pressure Seal Removal

4. Apply Pure Goop to the threads on the high pressure plug and gland fitting. Thread the plug and gland fitting into the discharge gland nut on the sealing head and hand tighten.
5. Position the cylinder assembly upright in the seal removal tool stand. If a tool stand is not available, position the cylinder on a platform of wooden blocks with the jackbolts resting on the platform.



Do not stand the cylinder assembly on the drip pan. The assembly is heavy and must be properly supported to prevent it from falling.

6. Fill the cylinder with water and slide the seal removal tool or a used plunger into the bronze packing follower to ensure a good seal for the removal of the seal assembly.
7. Place a shop towel around the plunger or seal removal tool to avoid splash back. Use a dead blow hammer to drive the removal tool or plunger into the cylinder until the seal components move up and out of the cylinder.
8. Remove the cylinder liner from the bore and inspect for possible heat or wear damage, or for debris. If cracks or brittleness are detected on the tabs on the ends of the liner, the liner must be replaced.

9. Feel approximately one inch into the cylinder bore for obvious ridges or grooves. If seal debris is present, follow the procedure, High Pressure Cylinder Maintenance.
10. Inspect the plunger surface for flaws. Rotate the plunger 360 degrees by hand while viewing light reflection on the surface to detect any dullness, streaks, pits or other defects. Run a fingernail perpendicular to the direction of the suspected flaws to determine the severity of defects. Depending on the seal life achieved with the removed seal assembly, make a judgment regarding plunger and/or cylinder replacement. If seal debris is present on the plunger, polish with 600-grit wet/dry sandpaper, using a radial motion.
11. Lightly coat the new seal components with FML-2 grease and install the new components on the plunger. Ensure the proper orientation of the backup rings as illustrated in Figure 9-20, High Pressure Seal Assembly.

Figure 9-20: High Pressure Seal Assembly

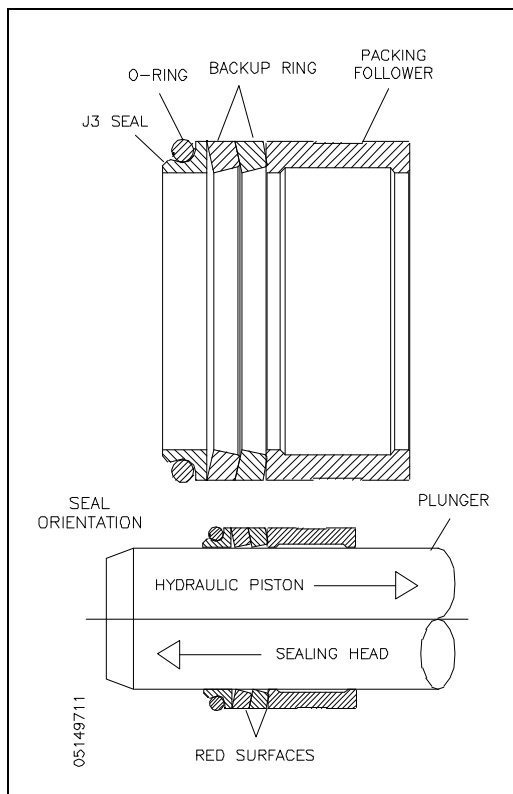

12. Slide the cylinder liner over the plunger.
13. Install the high pressure cylinder assembly, following the procedure, High Pressure Cylinder Assembly Installation.
14. Install the high and low pressure water connections, following the procedure, High and Low Pressure Water Connections.

9.11 Hydraulic Cartridge Seal and Plunger Removal

The following procedure is used to remove the hydraulic cartridge seal and the plunger.

Prior to removing electrical power or any high or low pressure piping, start the machine from the Maintenance Screen on the control panel. The machine will start in maintenance mode; the dump valve will open and relieve the high pressure in the system.

Press the RIGHT or LEFT arrow to extend the plunger on the end to be serviced. The plunger will extend in the selected direction, allowing full exposure when the unit is disassembled.

1. Turn the machine off and observe the appropriate Lockout/Tagout procedures.



Severe injury can result if the machine is not properly locked out. Observe electrical Lockout/Tagout procedures before proceeding.

Ensure all pressure is relieved or blocked from the hydraulic and high pressure circuits before proceeding.

2. Disconnect the high and low pressure water connections, following the procedure, High and Low Pressure Water Connections.
3. A hydraulic hose runs from the manifold to the hydraulic gauge for each intensifier. Disconnect the hose from the hydraulic gauge for the intensifier being serviced. Move the end of the hose to a bucket and drain the oil from the hose.
4. Remove the proximity switch on the end of the hydraulic cylinder to be serviced.
5. Remove the high pressure cylinder assembly, following the procedure, High Pressure Cylinder Assembly Removal.
6. Use a flat screwdriver to remove the retaining ring from the hydraulic cylinder head.

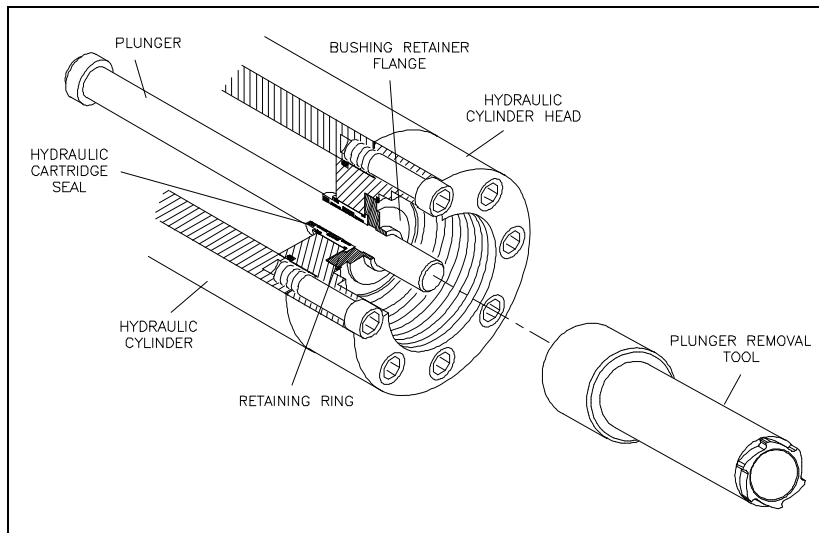
Figure 9-21: Hydraulic Cartridge Seal Removal

7. Remove the bushing retainer flange and clean the surfaces, weep holes and grooves. Check the retainer flange for cracks.
8. Replace the proximity switch by positioning the o-ring spacer and the switch. Apply JL-M grease to the threads on the socket head screws and tighten, following the torque specifications in Table 9-3.
9. Connect the hose to the hydraulic gauge.



It is recommended that the proximity switch and hydraulic hose be reinstalled as soon as practical. Removal of the switch and hose presents the potential of an oil spray hazard.

To prevent the spray of hydraulic oil, ensure that the proximity switch is properly installed and secured, and the hydraulic hose is tightened prior to starting the machine.

10. Remove the collet from the plunger removal tool and thread the large end of the tool onto the hydraulic cartridge seal and pull the cartridge out, over the plunger.
11. With the cartridge removed, the plunger can now be removed with the hydraulic cylinder head in place. The plunger is held in position by six retainer pins. The pins close around the plunger button to retain the plunger, and retract to release the plunger.

Clean the plunger and the ID of the collet with alcohol or a similar solvent. Partially thread the collet into the plunger removal tool and slide the removal tool over the plunger with the lobed end toward the plunger button. Note the orientation of the retainer pins on the plunger button. Align the lobes on the tool with the retainer pins as shown below. Tighten the collet and rotate the tool slightly, causing the pins to retract and release the plunger. Remove the plunger from the hydraulic piston.

Figure 9-22: Plunger Retainer Pins

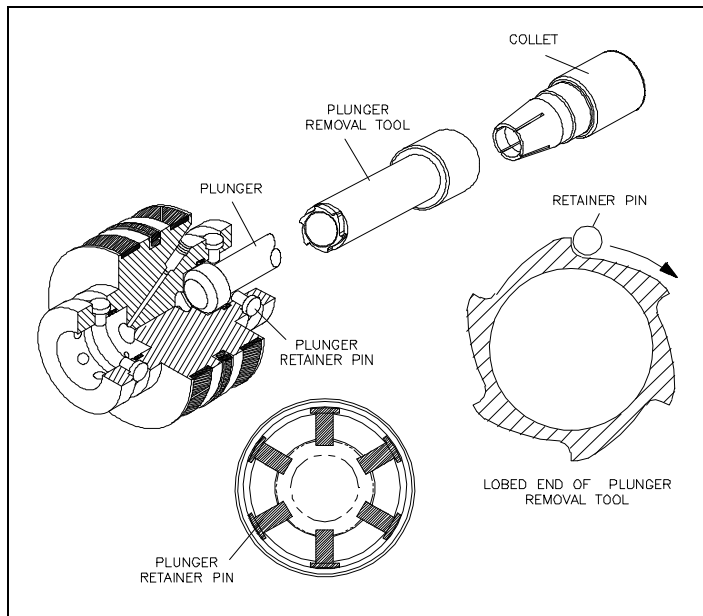

Plunger Maintenance

Plunger surfaces can become streaked with longitudinal scratches or flaws, and discolored or dull in appearance. If any of these conditions become severe, the high pressure seal assembly and possibly the hydraulic cartridge seal will leak.

Accumulation of debris on the surface of the plunger can be removed by polishing in a radial direction with 600-grit sandpaper. However, plunger surface flaws usually cannot be repaired on site. The plunger can be returned to KMT Waterjet for reconditioning.

Figure 9-23: Plunger

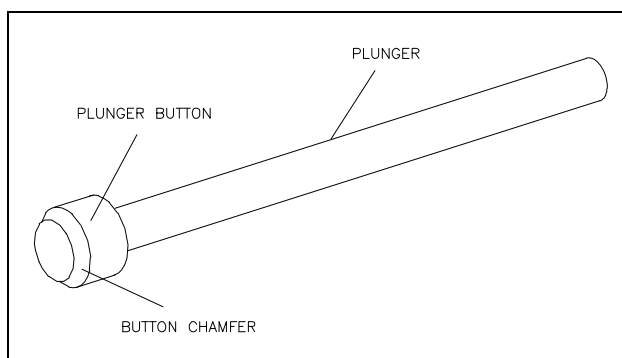

Plunger Installation

To install the plunger, slide the plunger removal tool over the plunger with the lobed end toward the plunger button to help center the plunger in the hydraulic cylinder head. Position the plunger in the button socket of the piston and force the plunger into place by hand. Use a flashlight to verify that all six pins are equally extended to grip the plunger button.

Hydraulic Cartridge Seal

Seals in the hydraulic cartridge can be removed and replaced, or the complete cartridge can be replaced.

Use caution during the removal and installation of the seal components to avoid scratching the surface of the cartridge. A plastic or wooden dowel, or similar object can be used for seal removal. **Do not** use screwdrivers, wires or other metal objects that could damage the cartridge.

Figure 9-24: Hydraulic Cartridge Seal

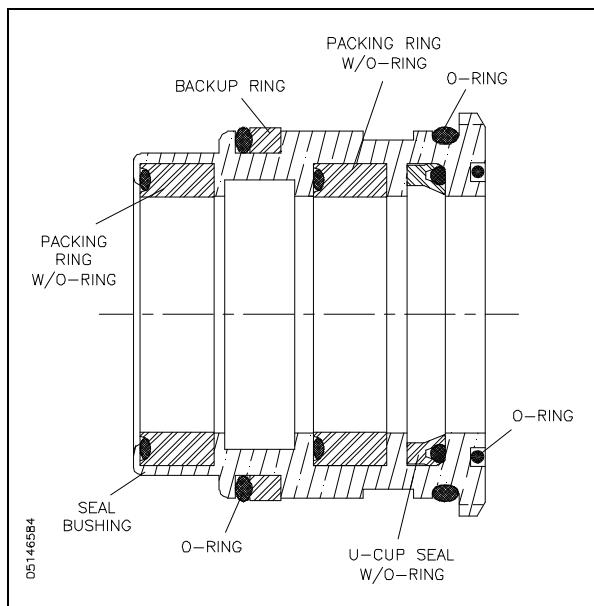

1. Carefully remove the worn seals and o-rings from the cartridge by pushing them with a plastic or wooden dowel, or similar object. Remove the seals closest to the open ends first, and work toward the center.
2. Inspect the seals for unusual wear, deformation or cuts. Note any unusual buildup of solid material or debris creating possible leak paths.
3. Inspect the surface of the cartridge body for scratches, deformation, signs of metal-to-metal contact or other unusual wear. Carefully examine the surface of the grooves on the inside diameter. Note any scratches in the axial direction that could create a leak path.
4. Install the seals, starting in the center and working toward the ends. See Figure 9-24 for the proper orientation of the u-cup seals.



5. Verify that the u-cup o-rings are properly positioned after installation.
6. When the seal components are properly installed, apply FML-2 grease to the exposed surfaces of the seals and slide the hydraulic cartridge seal over the plunger, into the cavity of the hydraulic cylinder head.
7. Thoroughly clean the bushing retainer flange, including the cross-drilled weep holes. Install the retainer flange over the plunger.
8. Install the retaining ring, ensuring the retaining ring fully seats inside the groove in the hydraulic cylinder head.

The o-rings on the hydraulic cartridge will take up clearance. Tap lightly on the bushing retainer flange with the plunger removal tool to compress the o-rings enough to start the retaining ring in the groove. Use a flat blade screwdriver to push on the outer edge of the retainer flange while working one end of the retaining ring into the groove. The retainer flange should tilt or tip enough to allow the retaining ring to move into the groove. Continue working the ring into the groove while tilting the retainer flange until the ring is fully seated.

9. Install the high pressure cylinder assembly into the hydraulic cylinder head, following the procedure, High Pressure Cylinder Assembly Installation.
10. Install the high and low pressure water connections, following the procedure, High and Low Pressure Water Connections.

9.12 Hydraulic Piston

Two bearing rings provide wear contact between the piston and the inside diameter of the hydraulic cylinder. On each end of the piston, six retainer pins hold the plunger in position. The plunger retainer pins are held in place by a flat snap ring. Two internal check valves vent unwanted hydraulic pressure from one side of the piston to the other, preventing pressure from building behind the plunger button.

Figure 9-25: Hydraulic Piston Components

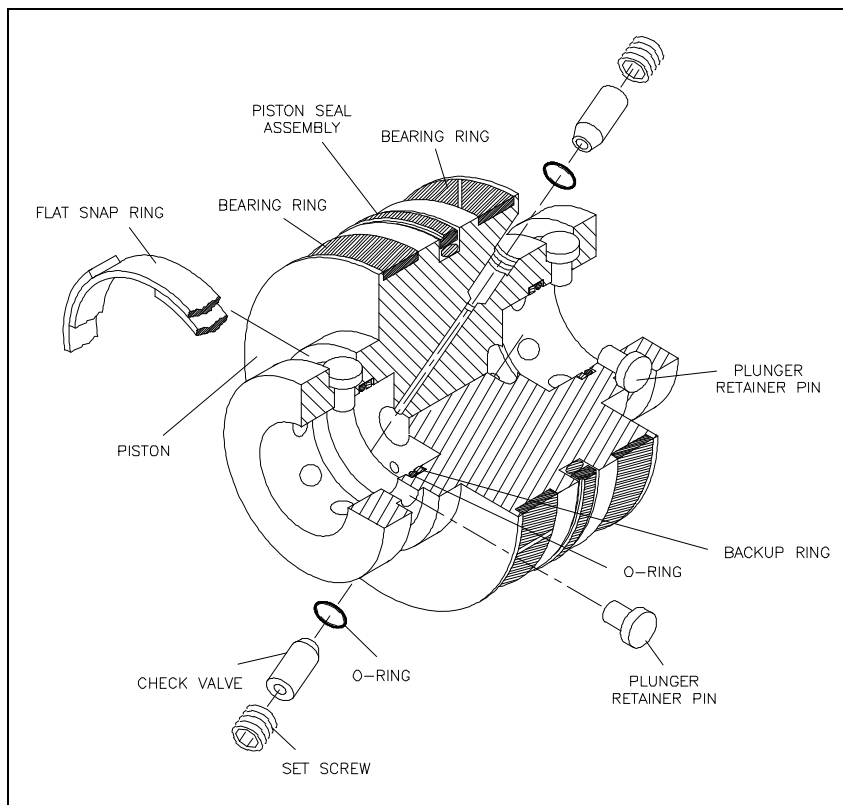

Hydraulic Piston Removal

The following procedure is used to remove the hydraulic piston.

1. Turn the machine off and observe the appropriate Lockout/Tagout procedures.



Severe injury can result if the machine is not properly locked out. Observe electrical Lockout/Tagout procedures before proceeding.

Ensure all pressure is relieved or blocked from the hydraulic and high pressure circuits before proceeding.

2. Disconnect the high and low pressure water connections from both ends of the intensifier, following the procedure, High and Low Pressure Water Connections.
3. Remove the high pressure cylinder assembly on each end of the intensifier, following the procedure, High Pressure Cylinder Assembly Removal.

Figure 9-26: Hydraulic Piston Removal

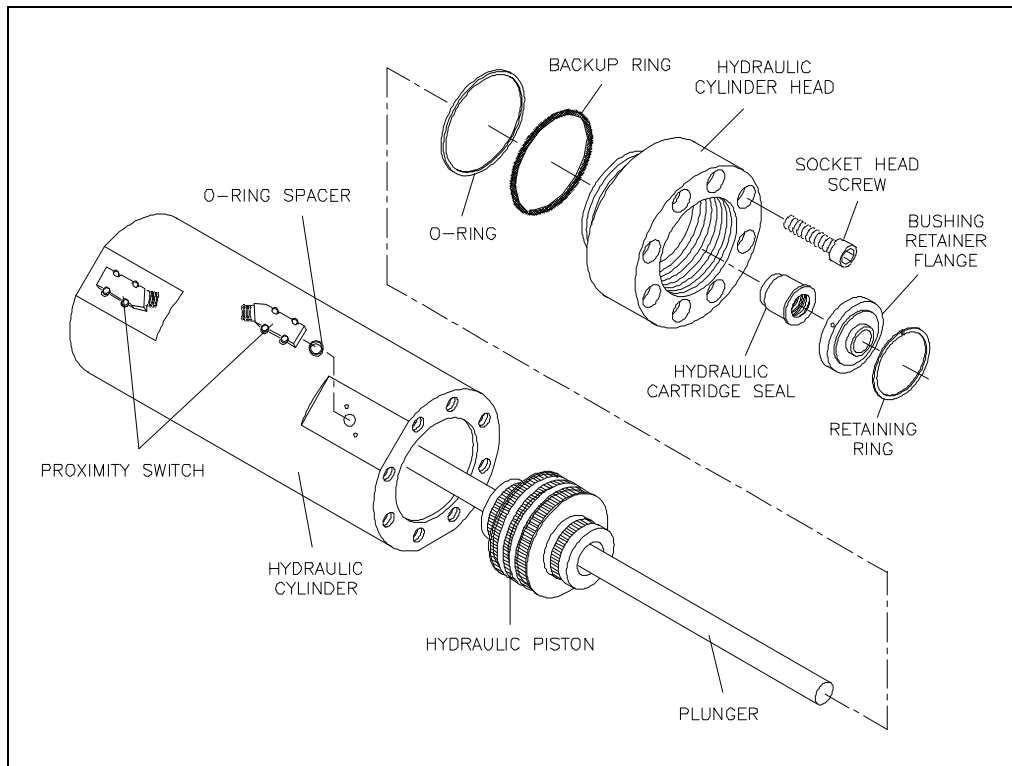

4. A hydraulic hose runs from the manifold to the hydraulic gauge for each intensifier. Disconnect the hose from the hydraulic gauge for the intensifier being serviced. Move the end of the hose to a bucket and drain the oil from the hose.
5. Remove both of the proximity switches to prevent interference.
6. Remove the retaining ring, bushing retainer flange and the hydraulic cartridge seal from both hydraulic cylinder heads. It is not necessary to remove the plungers.
7. Loosen and remove the socket head screws in one of the hydraulic cylinder heads.
8. Remove the hydraulic cylinder head with the o-ring and backup ring. The mounting flat for the proximity switch provides a small lip for loosening the cylinder head.
9. Grasp the plunger firmly and pull the piston out of the hydraulic cylinder.

Bearing Rings and Seal Assembly

1. Remove the plungers, following the procedure, Hydraulic Cartridge Seal and Plunger Removal.
2. Use a smooth, dull-edged blade made from brass or similar soft metal material to remove the two bearing rings and the seal assembly.

NOTE

Do not scratch the surfaces of the piston seal groove. Scratches on the sides or bottom of the groove can result in hydraulic leaks.

3. Inspect the bottom of the seal grooves for marks, scratches and residue buildup. Clean and/or repair the groove surfaces as required.
4. Apply FML-2 grease to the new bearing rings and install the rings.
5. The piston seal assembly consists of an inner and an outer seal ring. Apply FML-2 grease to both rings. Use the smooth, dull-edged blade to install the inner ring, ensuring the ring is not twisted after installation. Slide the outer seal ring over the metal edges and ease it into position over the inner ring.

Figure 9-27: Hydraulic Piston

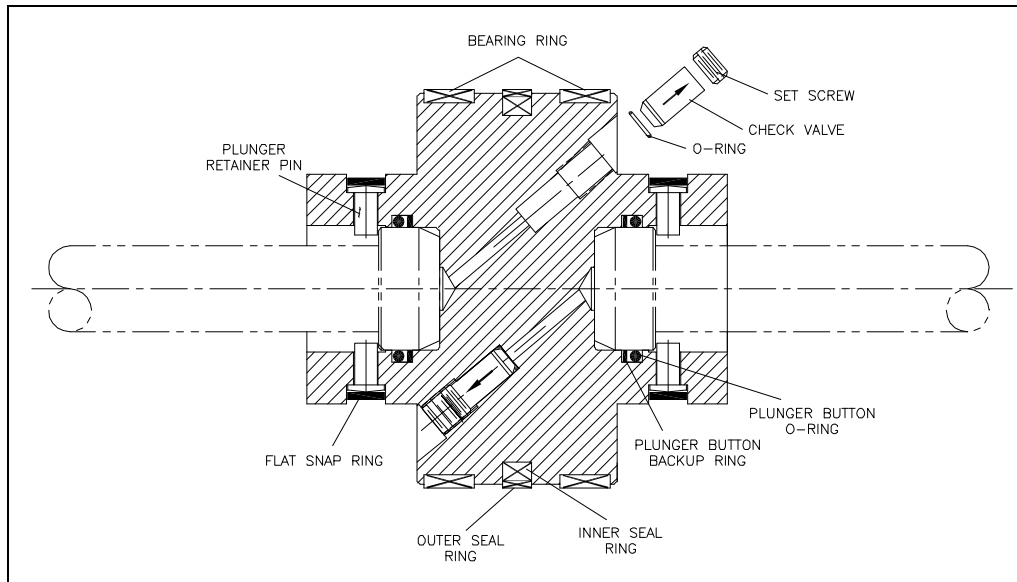

Plunger Button Sockets, Seals and Retainer Pins

1. Remove the flat snap rings and plunger retainer pins on both ends of the piston.
2. Inspect the snap rings and the pins for unusual wear or deformation. Clean and inspect the pin holes for unusual wear, deformation or hole enlargement.
3. Remove the plunger button o-ring and backup ring from each plunger socket. Take care not to scratch or damage the seal groove surfaces.
4. Clean and inspect the seal grooves for residue buildup or surface marks that could cause seal leaks.
5. Inspect the plunger button sockets for unusual wear.

NOTE

Due to the high contact force between the piston and the plunger, the plunger may make an impression in the bottom of the socket. This compression mark or indentation is normal.

6. Apply FML-2 grease to new plunger button backup rings and o-rings. Install the rings, in the proper sequence, in the internal groove in the plunger socket. If the rings are not installed the plunger can be forced out of the plunger socket.
7. Install the retainer pins, verifying that each pin moves freely without excess side play in the pin holes.
8. Install the flat snap ring over the pins.
9. Install the plungers and check the snap-in feature of the plunger attachment. Use the plunger removal tool to ensure the pins retract to release the plunger, and close to retain the plunger in a uniform manner.

Internal Check Valves

It is not necessary to service the internal check valves unless a problem is suspected. If the check valves or the internal passages in the piston require service, plunger button, seal and pin servicing is also recommended. See Figure 9-27, Hydraulic Piston.

1. Loosen the set screws and remove the check valves and o-rings. Clean the internal passages.
2. Apply FML-2 grease to a new o-ring and install the new o-ring in the check valve passage. Use a blunt, pencil-like instrument to position it in the bottom of the passage.
3. Clean and install a new check valve with the chamfered end toward the o-ring.

4. Sparingly apply Loctite, threadlocker adhesive to the set screw. Thread the screw over the check valve cartridge and tighten.

NOTE

Excess threadlocker adhesive can clog the check valve or block the internal passage. To avoid excess adhesive, position the set screw on an allen wrench and apply the adhesive. Hold the screw horizontal on a paper towel and rotate the screw to remove excess adhesive.

Hydraulic Piston Installation

1. Ensure that the hydraulic cylinder bore is free of grit or contamination.
2. Lubricate the bearing rings and seal assembly, and lightly lubricate 2-3 inches of the cylinder bore with FML-2 grease.

Figure 9-28: Hydraulic Piston Installation

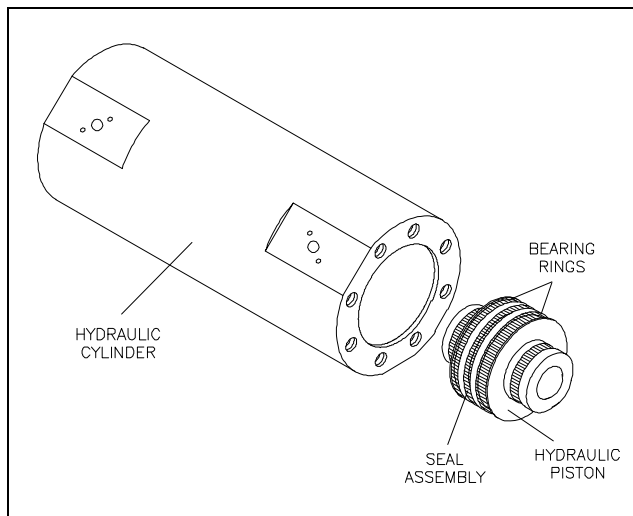

3. Install the piston into the hydraulic cylinder bore. If necessary, use a plastic head hammer to drive the piston into position between the holes for the proximity switches.
4. Install the plungers and check the snap-in feature of the plunger attachment. Use the plunger removal tool to ensure the pins retract to release the plunger, and close to retain the plunger in a uniform manner.
5. Verify that the o-ring and backup ring are properly positioned in the groove on both hydraulic cylinder heads, and that they are sufficiently lubricated with FML-2 grease.
6. Position the cylinder heads in the ends of the hydraulic cylinder. Apply JL-M grease to the threads on the socket head screws. Install the screws in each hydraulic cylinder head and tighten, following the torque specifications in Table 9-3.

7. Replace the hydraulic cartridge seal, bushing retainer flange and retaining ring in both hydraulic cylinder heads.
8. Replace the proximity switches by positioning the o-ring spacers and the switches. Apply JL-M grease to the threads on the socket head screws and tighten, following the torque specifications in Table 9-3.
9. Connect the hose to the hydraulic gauge.



To prevent the spray of hydraulic oil, ensure that the proximity switches and the hydraulic hose are properly installed and secured prior to starting the motor.

10. Install the high pressure cylinder assemblies into the hydraulic cylinder heads, following the procedure, High Pressure Cylinder Assembly Installation.
11. Install the high and low pressure water connections, following the procedure, High and Low Pressure Water Connections.

9.13 Hydraulic Cylinder Maintenance

The inside diameter surface of the hydraulic cylinder should be inspected for wear grooves and surface finish whenever the hydraulic cylinder heads are removed. Excessive grooving is indicative of piston seal wear.

9.14 High Pressure Attenuator

The high pressure attenuators are not serviceable at the customer level. KMT Waterjet Systems tests the seals in the attenuator at pressures exceeding normal operating pressure, making disassembly difficult. If an attenuator develops a high pressure water leak, it should be replaced.

9.15 High Pressure Dump Valve

The high pressure dump valve assembly includes a normally open high pressure water valve and a solenoid operated air valve. The following procedure is recommended for servicing the high pressure dump valve. Failure to follow this procedure will cause damage to the stem, valve seat, or both.



The high pressure dump valve is a safety device designed to instantly release high pressure from the system. **Proper maintenance is imperative** to prevent potential personal injury.

Figure 9-29: High Pressure Dump Valve

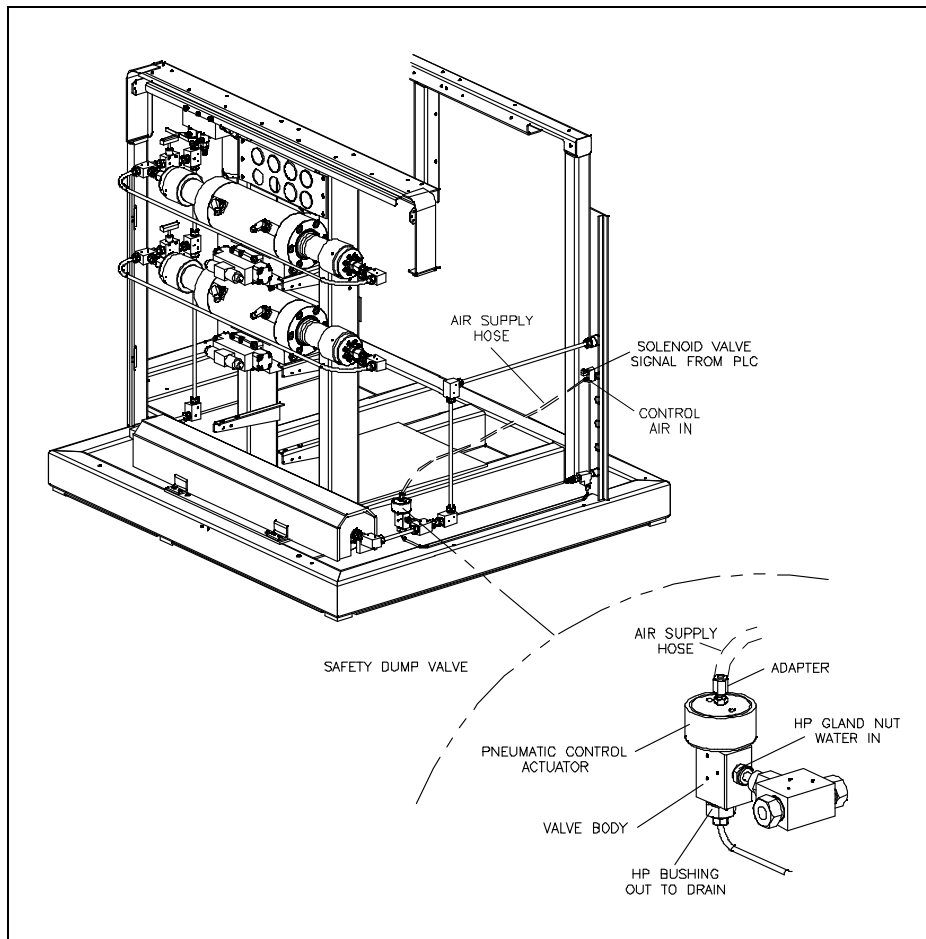

Pneumatic Control Valve

Figure 9-30, Pneumatic Valve Seal Tools, illustrates the special tools recommended for this procedure.

Figure 9-30: Pneumatic Valve Seal Tools

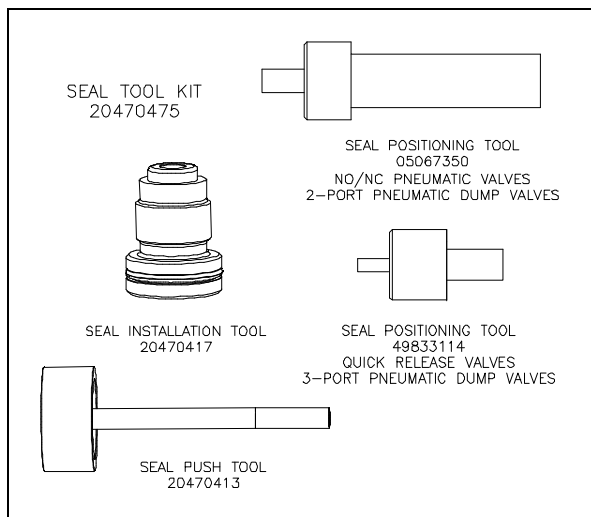

For reliable operation, it is recommended that the valve seat, seal assembly, brass backup ring and stem always be replaced at the same time. The SST backup ring can be reused.



Severe injury can result if the machine is not properly locked out. Observe electrical Lockout/Tagout procedures before proceeding.

Ensure all pressure is relieved or blocked from the hydraulic and high pressure circuits before proceeding.

1. Turn the air supply off.
2. Remove the air supply hose, and the electrical connection to the solenoid valve.
3. Loosen and remove the high pressure gland connection and the drain connection.
4. Remove the valve and actuator assembly from the machine.

Figure 31: Dump Valve Components

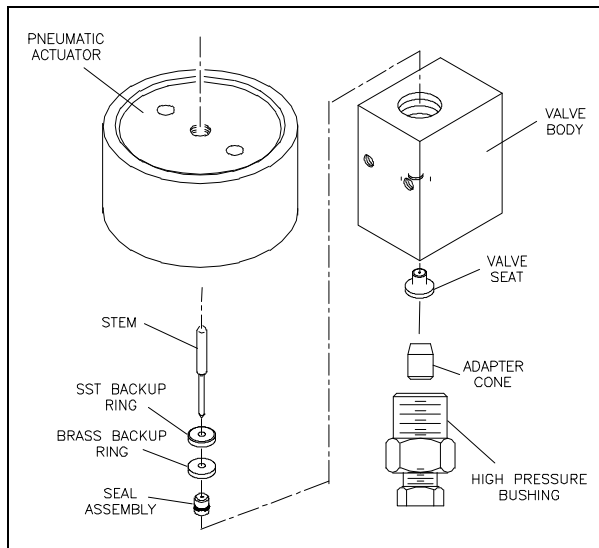

5. Loosen the cylinder head on the actuator. Unscrew and remove the actuator from the valve body.
6. Unscrew the high pressure bushing and remove the bushing, adapter cone and valve seat.
7. Remove the stem, SST backup ring and brass backup ring from the valve body.
8. Remove the seal assembly by pushing it with the seal push tool (P/N 20470413). The assembly must be pushed out through the actuator port in the top of the valve body.
9. **Discard** the stem, brass backup ring, seal assembly and valve seat.
10. Clean and inspect the valve body, being careful not to damage or scratch the bore.

Figure 9-32: Valve Seal Installation

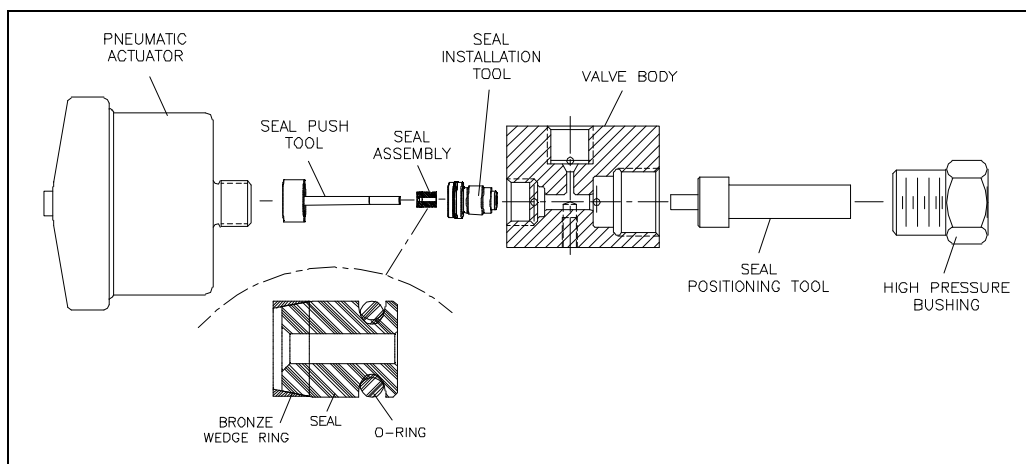

11. Place the seal positioning tool into the end of the valve body as shown above. Thread the high pressure bushing into the valve body until light contact is made with the positioning tool. **Tighten finger-tight only.** See Figure 9-32, Valve Seal Installation.
12. Apply Pure Goop anti-seize compound to the threads on the seal installation tool. Screw the seal installation tool into the threads of the valve body. **Tighten finger-tight only.** See Figure 9-32, Valve Seal Installation.
13. Lubricate the seal and the o-ring with FML-2 food grade grease. Insert the seal and o-ring, with the bronze wedge ring, into the seal installation tool. Insert the o-ring end of the seal first so the tapered end of the seal (wedge ring end) faces the actuator. The tapered end of the seal must face the actuator. See Figure 9-32, Valve Seal Installation.
14. Use the seal push tool to push the seal assembly into the bore of the valve body until the seal makes light contact with the positioning tool.
15. Remove the push tool and the installation tool from the valve body.
16. Install the existing SST backup ring and a new brass backup ring on a new stem. The vee groove on the SST backup ring must face toward the brass backup ring. The small OD of the brass backup ring must face toward the seal assembly.
17. Apply FML-2 grease to the tip of the stem and insert the stem with the backup rings into the top of the valve body so the stem enters the ID of the seal assembly. **Insert the stem until the chamfer on the stem is seated against the SST backup ring.** See Figure 9-33, Valve Stem Placement.



Do not push the o-ring on the seal assembly past the inlet port on the valve body. This will damage the seal o-ring.

Figure 9-33: Valve Stem Placement

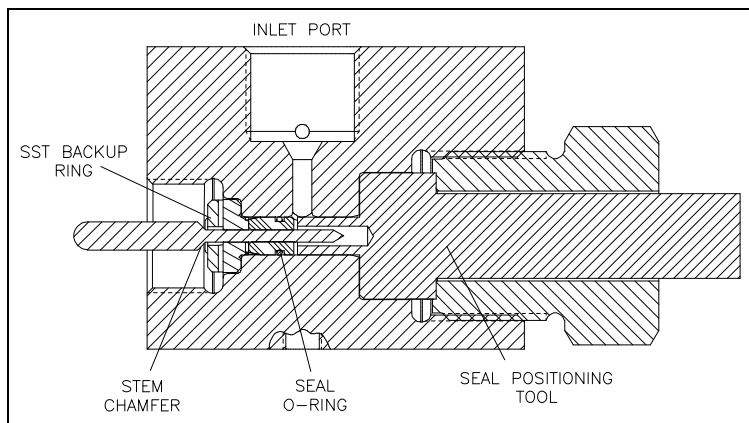



18. Remove the high pressure bushing and the seal positioning tool.
19. Apply Pure Goop anti-seize compound to the threads of the actuator and carefully thread it into the valve body, guiding the stem head into the hole in the actuator. Turn the actuator clockwise until resistance is felt. Reverse the actuator 1/4-turn, and give it a quick spin clockwise to seat it. **Hand-tighten only, 5 ft-lbs (7 Nm).**
20. Apply Pure Goop anti-seize compound to all surfaces, except the ID, of a new valve seat. Install the seat into the opposite end of the valve body, inserting the small OD first.
21. Apply anti-seize compound to the threads on the high pressure bushing, and on the back side of the adapter cone. Position the adapter cone in the bushing, install the bushing and torque to 50 ft-lbs (68 Nm).
22. Replace the 1/4-inch gland nut and collar and torque to 25 ft-lbs (34 Nm).
23. Apply anti-seize compound to the threads on the 3/8-inch high pressure gland fitting. Install the collar and the gland fitting and torque to 50 ft-lbs (68 Nm).
24. Install the air supply hose and the electrical connection to the solenoid valve. Turn the air pressure to the actuator on and test the valve for leaks and proper operation.

Pneumatic Actuator

The following procedure is used to service the pneumatic actuator.

Figure 9-34: Pneumatic Actuator

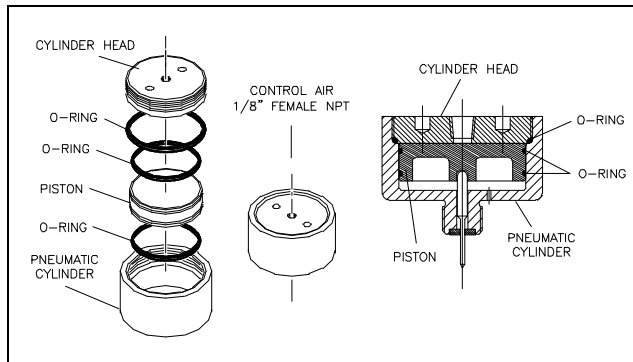

1. Remove the air hose adapter from the cylinder head.
2. Unscrew and remove the cylinder head using a strap wrench and a pin spanner. Remove the piston from the cylinder.



Do not install the pneumatic cylinder in a vise to remove the cylinder head. This may distort the body and seize the piston, preventing proper operation.

3. Remove the o-ring on the cylinder head. Apply FML-2 grease to a new o-ring and install.
4. Remove the two o-rings on the piston. Apply FML-2 grease to two new o-rings and install.
5. Install the piston in the pneumatic cylinder. Apply anti-seize compound to the threads on the cylinder head and screw it into the pneumatic cylinder.
6. Install the air hose adapter.

9.16 Weep Holes

High pressure seals and connections fail gradually and begin leaking slowly. Weep holes are located at every threaded high pressure connection to provide a vent for internal leaks. Water or oil dripping from a weep hole indicates one or more internal components are beginning to fail.

Table 9-5 lists the location of the weep hole, the possible source of the leak and the corrective action required.

Table 9-5
Weep Holes
High Pressure Water System

Location	Indication	Comments
<i>Hydraulic Cylinder Head</i>		
Hydraulic oil leaking from the weep hole in the hydraulic cylinder head	Failed hydraulic cartridge seal	Replace the cartridge seal. If the leak persists, check the plunger for linear scratches or scoring.
Water leaking from the weep hole on the hydraulic cylinder head flange	Failed high pressure seal assembly	Replace the high pressure seal assembly.
	Damaged plunger	Check the plunger for longitudinal scratches or flaws. If detected, replace the plunger or return to KMT for evaluation.
	Seal material buildup on plunger	Polish the plunger surface following the procedure, Plunger Maintenance.
	Damaged high pressure cylinder	Check for scratches, grooves or material buildup on the inside diameter of the cylinder. If detected, polish the bore following the procedure, High Pressure Cylinder Maintenance.
Check the inside diameter of the cylinder for expansion where the high pressure seal assembly is located. If detected, replace the cylinder.		



**Table 9-5
Weep Holes
High Pressure Water System**

Location	Indication	Comments
<i>Sealing Head</i>		
Water leaking from the weep hole in the sealing head	Seat in the discharge check valve is not sealing properly	Make sure the gland nut is tightened to the proper torque specification. Inspect the seat, sealing head and gland nut for cracks.
	Internal crack in sealing head	Replace the sealing head. <i>A cracked sealing head can result in water leaking from the high pressure outlet passage to the low pressure inlet passages.</i> <i>The sealing head body can become extremely hot.</i>
	Improper torque on gland nut	Tighten the gland nut to the proper torque specification.
	Erosion or scratches on the contact surface of the sealing head, or on the gland nut where the seat makes contact	Polish the surfaces following the procedure, Sealing Head Maintenance.
	Water leaking from the weep hole in the gland nut	High pressure piping gland nut is not tight and is not sealing properly
Water leaking from the weep hole in the gland nut	Improper high pressure piping connection	Check the number of exposed threads past the collar on the high pressure piping. Only 1-1/2 to 2-1/2 threads should be exposed.
		Check high pressure piping for damage, cracks or deformation.
		Inspect the gland nut for deformation of the threads.
Water leaking from the weep hole in the gland nut	Damaged sealing head gland nut	Check the gland nut for cracks due to fatigue. If cracks are detected, replace the gland nut.



Table 9-5
Weep Holes
High Pressure Water System

Location	Indication	Comments
<i>Hard Seal End Cap</i>		
Water leaking from the weep holes in the hard seal end cap	Damaged high pressure cylinder	Check for scratches or grooves on the 45-degree cone seal surface. If detected, polish to remove following the procedure, High Pressure Cylinder Maintenance.
	External crack in sealing head	Replace the sealing head.
	Damaged sealing head	Check for scratches or grooves on the 45-degree surface of the sealing head. If detected, polish the surface following the procedure, Sealing Head Maintenance.
	Improper torque on jackbolts	Re-torque the jackbolts to the proper torque specification.



SECTION 10

TROUBLESHOOTING

10.1 Overview

The troubleshooting guide will help identify the probable cause of a system malfunction and assist in providing corrective action. Softstarter faults are discussed following the troubleshooting guide.

The following symptoms are discussed in the troubleshooting guide.

1. High boosted water temperature
2. Booster pump pressure drop is greater than 30 psi (2 bar) during stroke condition
3. Outlet booster pump pressure is falling below 60 psi (4 bar)
4. Inlet water flow is poor and the filter housing is not filling completely
5. Water is leaking around the bleed valve on the filter head
6. High oil temperature resulting in shutdown
7. Low oil level resulting in shutdown
8. Restricted or no cooling flow
9. Hydraulic pressure but no high pressure water pressure
10. Erratic fluctuations in the operating pressure, or inability to reach or maintain set pressure
11. No hydraulic oil pressure
12. Pump shaft will not turn
13. Pump will not start
14. Console display and lights do not illuminate
15. Pump quits running
16. No control power
17. Red light on operator's console is flashing
18. Abnormal fluctuations in high pressure water signal
19. Hot surfaces on the high pressure cylinder components
20. Low cutting water supply pressure
21. Low cutting water pressure
22. Hydraulic oil leaking from the weep hole in the hydraulic cylinder head
23. Water leaking from the weep hole on the hydraulic cylinder head flange
24. Water leaking from the weep hole in the sealing head
25. Water leaking from the weep hole in the sealing head gland nut
26. Water leaking from the weep holes in the hard seal end cap

10.2 Troubleshooting Guide

Listen to the machine and observe it in operation. Learn to recognize the normal sounds and operating conditions of the system. Carefully define the symptom of the problem. Locate the symptom on the troubleshooting guide that most closely corresponds to the problem.

If the symptoms in the guide do not correspond to the malfunction, or if the problem is not resolved by the recommended corrective action, contact the KMT Customer Service Department for assistance.

SL-V 200 Troubleshooting Guide

Malfunction		Indication	Comments
1.	High boosted water temperature	Long deadhead condition	
		Insufficient water supply	
		Booster pump temperature switch malfunction	
2.	Booster pump pressure drop is greater than 30 psi (2 bar) during stroke condition	Inlet water pressure or flow is low	
		Filter element is dirty and needs to be replaced	
		Booster pump is starting to fail	
3.	Outlet booster pump pressure is falling below 60 psi (4 bar)	Inlet water pressure is low	
		Filter element is dirty and needs to be replaced	
		Relief valve needs to be adjusted or booster pump needs to be or replaced	
4.	Inlet water flow is poor and the filter housing is not filling completely	Pipe sizing for inlet cutting water should be checked for pressure and flow	Cutting water supply will be lacking capacity or flow.
		Inlet strainer is clogged	Clean the inlet strainer.
5.	Water is leaking around the bleed valve on the filter head	O-ring that closes the passage has deteriorated	A small o-ring under the valve can deteriorate causing the passage to remain open. The o-ring can be replaced by removing the screw and spring on the underneath side.



SL-V 200 Troubleshooting Guide

	Malfunction	Indication	Comments
6.	High oil temperature resulting in shutdown	Cooling water flow is restricted	Check cooling water source for proper temperature and flow rate.
		Water modulating valve is stuck open or closed	Replace the valve.
		Scale build up in the heat exchanger has restricted the flow	The heat exchanger will need to be flushed or replaced.
7.	Low oil level resulting in shutdown		Check the level gauge.
			Check for hydraulic leaks.
			Check the level switch.
8.	Restricted or no cooling flow	Check cooling water flow to and from the heat exchanger	The water pressure differential across the heat exchanger requires a minimum of 35 psi (2.4 bar) for flow through the exchanger.
		Water modulating valve is stuck or out of adjustment	Replace the valve.
			Adjust the valve.



SL-V 200 Troubleshooting Guide

	Malfunction	Indication	Comments
9.	Hydraulic pressure but no high pressure water pressure	Proximity switch failure	From the Maintenance Screen on the control panel, jog the intensifier left and right and verify that the red light comes on at both proximity switches.
		I/O relay failure	From the Maintenance Screen on the control panel, jog the intensifier left and right and verify that the green light comes on at both directional valve solenoids.
		Coil failure on the directional control valve	Check the coils on the directional valve with an ohm meter to verify if they are good or bad.
		PLC failure	If there are inputs from the proximity switches, but no outputs, contact the KMT Customer Service Department for a logic review and verification of PLC failure.
10.	Erratic fluctuations in the operating pressure, or inability to reach or maintain set pressure	The screen in the proportional pressure valve is blocked with debris	Remove the valve and clean the screen following the maintenance procedure in Section 7, Hydraulic System.
11.	No hydraulic oil pressure	The high and low limit compensators on the hydraulic pump are blocked with debris and are not controlling the swashplate	Disassemble the compensators, clean and inspect the components following the maintenance procedure in Section 7, Hydraulic System.
		Incorrect motor rotation	Check the motor rotation.
12.	Pump shaft will not turn	The flexible coupling has failed	Replace the flexible coupling.
		The hydraulic pump has seized	Replace the hydraulic pump.



SL-V 200 Troubleshooting Guide

	Malfunction	Indication	Comments	
13.	Pump will not start	Emergency stop button is depressed	Pull the E-STOP button out.	
			Check all remote E-STOP buttons.	
		Main power is disconnected	Check the main power and verify that the main power disconnect is on.	
			Control power has been interrupted	Check the power supply circuit for a tripped breaker.
				Check the input and output of the 24 volt DC power supply.
		Check the 2K1 relay.		
		A protection fault has been activated	Check the display panel for fault messages.	
Motor overload relay has been tripped	Identify the source of the overload and remedy the problem. Reset the overload relay.			
Inlet water valve is turned off	Press the RESET button on the Run Screen to reset the water valve.			
14.	Console display and lights do not illuminate	Main power is disconnected	Check the main power and verify that the main power disconnect is on.	
			Control power is not available	Check the power supply circuit for a tripped breaker.
		Check the input and output of the 24 volt DC power supply.		

SL-V 200 Troubleshooting Guide

	Malfunction	Indication	Comments
15.	Pump quits running	Unsafe operation has been detected	Check the display panel for fault messages.
		Electrical power has been interrupted	Check the power supply circuit for a tripped breaker.
			Check the input and output of the 24 volt DC power supply.
			Verify that power is available at the main power source.
			Check the 2K1 relay coil.
		Check the 4K0 relay.	
Motor overload relay has been tripped	Identify the source of the overload and remedy the problem. Reset the overload relay.		
16.	No control power	Circuit breaker has been tripped	Check the input and output of all circuit breakers.
		Power supply fault	Check the input and output voltages at the power supply.
		Emergency stop button is depressed	Pull the E-STOP button out.
			Check all remote E-STOP buttons.
		Master control relay is not energized	Verify that the contactor coil is pulling in on the master control relay.
Contact set failure on the master control relay	Verify that the contact sets on the master control relay are changing states when the relay is energized.		



SL-V 200 Troubleshooting Guide

	Malfunction	Indication	Comments
17.	Red light on operator's console is flashing	An alarm condition has occurred	<p>Check the display panel for fault messages.</p> <p><i>Refer to Section 4, Operation, for additional information regarding warning and alarm conditions and recovery procedures.</i></p>
18.	Abnormal fluctuations in high pressure water signal	Large, worn or damaged orifice	Make sure the orifice does not exceed the capacity of the pump.
			Make sure the orifice is in good working condition. Verify that the jewel is installed in the orifice mount.
		Check valve leakage	Inspect the discharge check valves in the sealing heads.
			Inspect the inlet check valves in the sealing heads.
		Seal leakage	Inspect the high pressure seal on the plunger.
			Inspect the sealing head-to-cylinder sealing surfaces.
Hydraulic control malfunction	Check the operation of the hydraulic relief valve.		
	Verify that the directional control valve is shifting properly.		
	Check the operation of the proximity switches.		

SL-V 200 Troubleshooting Guide

	Malfunction	Indication	Comments
19.	Hot surfaces on the high pressure cylinder components	Leaking discharge check valve	Inspect the condition of the seat, poppet valve, spring, poppet pin and sealing head surface on the discharge end of the sealing heads.
		Leaking inlet check valve	Inspect the condition of the poppet valve, poppet retainer and the spring, if applicable, on the inlet end of the sealing heads.
		Damaged sealing head	Check the cone flange surface of the sealing head for scratches or mechanical damage and replace if necessary.
		Damaged high pressure cylinder	Check the high pressure cylinder for cracks.
20.	Low cutting water supply pressure	Restricted water supply	Check cutting water supply flow and pressure.
		Clogged water filter	Check the condition of the low pressure water filter and replace the filter element if necessary.
		Trapped air	Bleed the air from the cutting water plumbing.
21.	Low cutting water pressure	Low hydraulic pressure setting	Check the hydraulic pressure setting.
			Clean the compensators on the hydraulic pump.
		Collapsed element in the high pressure line filter	Check the element in the high pressure line filter.
22.	Hydraulic oil leaking from the weep hole in the hydraulic cylinder head	Failed hydraulic cartridge seal	Replace the cartridge seal. If the leak persists, check the plunger for linear scratches or scoring.



SL-V 200 Troubleshooting Guide

	Malfunction	Indication	Comments
23.	Water leaking from the weep hole on the hydraulic cylinder head flange	Failed high pressure seal assembly	Replace the high pressure seal assembly.
Damaged plunger		Check the plunger for longitudinal scratches or flaws. If detected, replace the plunger or return to KMT Waterjet for evaluation and rework.	
Seal material buildup on plunger		Polish the plunger surface following the procedure, Plunger Maintenance, detailed in Section 9, High Pressure Water System.	
Damaged high pressure cylinder		Check for scratches, grooves or material buildup on the inside diameter of the cylinder. If detected, polish the bore following the procedure, High Pressure Cylinder Maintenance, detailed in Section 9, High Pressure Water System.	
	Check the inside diameter of the cylinder for expansion where the high pressure seal assembly is located. If detected, replace the cylinder.		



SL-V 200 Troubleshooting Guide

	Malfunction	Indication	Comments
24.	Water leaking from the weep hole in the sealing head	Seat in the discharge check valve is not sealing properly	Make sure the gland nut is tightened to the proper torque specification.
			Inspect the seat, sealing head and gland nut for scratches, erosion or cracks.
		Improper torque on gland nut	Tighten the gland nut to the proper torque specification.
		Internal crack in sealing head	Replace the sealing head. <i>A cracked sealing head can result in water leaking from the high pressure outlet passages to the low pressure inlet passages.</i> <i>The sealing head body can become extremely hot.</i>
		Erosion or scratches on the contact surface of the sealing head, or on the gland nut where the seat makes contact	Polish the surfaces following the procedure, Sealing Head Maintenance, detailed in Section 9, High Pressure Water System.
25.	Water leaking from the weep hole in the sealing head gland nut	High pressure piping gland nut is not tight and is not sealing properly	Tighten the gland nut to the proper torque specification.
		Improper high pressure piping connection	Check the number of exposed threads past the collar on the high pressure piping. Only 1-1/2 to 2-1/2 threads should be exposed.
			Check high pressure piping for damage, cracks or deformation.
		Inspect the gland nut for deformation of the threads.	
Damaged sealing head gland nut	Check the gland nut for cracks due to fatigue. If cracks are detected, replace the gland nut.		



SL-V 200 Troubleshooting Guide

	Malfunction	Indication	Comments
26.	Water leaking from the weep holes in the hard seal end cap	Damaged high pressure cylinder	Check for scratches or grooves on the 45-degree cone seal surface. If detected, polish to remove following the procedure, High Pressure Cylinder Maintenance, detailed in Section 9, High Pressure Water System.
			Replace the high pressure cylinder.
		External crack in sealing head	Replace the sealing head.
		Damaged sealing head	Check for scratches or grooves on the 45-degree surface of the sealing head. If detected, polish the surface following the procedure, Sealing Head Maintenance, detailed in Section 9, High Pressure Water System.
		Improper torque on jackbolts	Re-torque the jackbolts to the proper torque specification.

10.3 Softstarter

The softstarter is a reduced voltage starter that minimizes system mechanical and electrical stress by reducing current surges. The following information describes the fault diagnostics of the softstart controller.



Hazardous voltage is present in the motor circuit even when the controller is off. Disconnect the main power before working on the controller, motor and control devices.

Procedures that require parts of the equipment to be energized during troubleshooting or testing must be performed by properly qualified personnel, using appropriate safety work practices and precautionary measures.

The fault display in Figure 10-1 indicates the unit has faulted, and displays the fault number and the fault code. The fault display will remain active as long as control power is applied. If control power is cycled, the fault will be cleared. Resetting a fault will not correct the cause of the fault condition. Corrective action must be taken before resetting the fault.

Figure 10-1: Fault Display

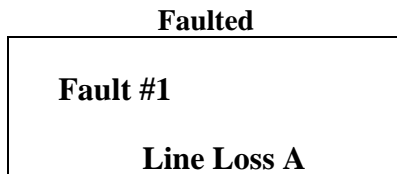

The flowchart in Figure 10-2 provides a quick troubleshooting guide.

Figure 10-2: Troubleshooting Flowchart

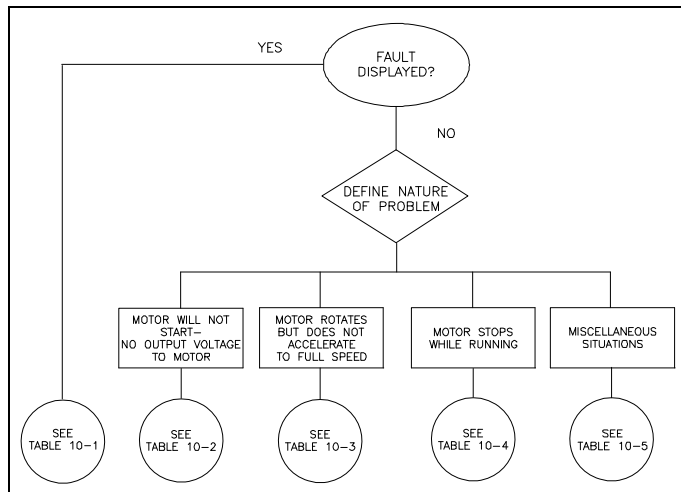

Table 10-1 describes the fault diagnostics and the conditions that cause various faults to occur.

Table 10-1
Fault Display Explanation

Fault Code	Display	Possible Cause	Possible Solution
1, 2, 3	Line Loss A, B or C (Prestart fault indication)	Missing supply phase	Check for an open line (i.e., blown fuse).
		Improper motor connection	Check for open load lead.
			See Note 1
4, 5, 6	Shorted SCR A, B or C <i>Starting will be prohibited.</i>	Shorted power module	See Note 1
7, 8, 9	Open Gate A, B or C <i>An abnormal condition that causes faulty firing has been sensed during the start sequence. The controller will attempt to start the motor a total of three times before it shuts down.</i>	Open gate circuitry	See Note 1
		Loose gate lead	
10	PTC Power Pole <i>If the temperature in a power pole rises above the predetermined level, the unit will fault to protect the power pole. A reset can be performed once the temperature falls below this level.</i>	Controller ventilation blocked	Check for proper ventilation.
		Controller duty cycle exceeded	Check application duty cycle.
		Fan failure	Replace fan.
		Ambient temperature limit exceeded	Wait for controller to cool or provide external cooling.
11	SCR Overtemp	Failed thermistor	See Note 1
		Failed control module	

Table 10-1
Fault Display Explanation

Fault Code	Display	Possible Cause	Possible Solution
12	Motor PTC	Motor ventilation blocked	Check for proper ventilation.
		Motor duty cycle exceeded	Check application duty cycle. Wait for motor to cool or provide external cooling.
		PTC open or shorted	See Note 1
13, 14 15	Open Bypass A, B or C <i>Power pole bypass contacts are monitored for proper operation. If a contact closure is not sensed, the controller will indicate an Open Bypass fault.</i>	Control voltage is low	Check control voltage power supply.
		Inoperable power module bypass	Check control module TB2...TB4 and TB%...TB7 for secureness. See Note 1
16, 17, 18, 40	No Load A, B, or C	Loss of load side power wiring	Check all load side power connections and motor windings.
19	Line Unbalance	Supply unbalance is greater than the user-programmed value	Check power system and correct if necessary.
		Delay time is too short for the application	See Note 1
20	Overvoltage	Supply voltage is greater than user-programmed value	Check power system and correct if necessary. See Note 1
			See Note 1
21	Undervoltage	Supply voltage is less than user-programmed value	Check power system and correct if necessary. See Note 1
			See Note 1
		Delay time is too short for the application	See Note 1



Table 10-1
Fault Display Explanation

Fault Code	Display	Possible Cause	Possible Solution
22	Overload	Motor overload	Check motor overload condition.
		Overload parameters are not matched to the motor	See Note 1
23	Underload	Broken motor shaft	Repair or replace motor.
		Broken belts, tool bits, etc.	Check machine.
		Pump cavitation	Check pump system.
24	Jam	Motor current has exceeded the user-programmed jam level	Correct source of jam.
			See Note 1
25	Stall	Motor has not reached full speed by the end of the programmed ramp time	Correct source of stall.
26	Phase Reversal	Incoming supply voltage is not in the expected ABC sequence	Check power wiring.
27, 28, 29	Coms Loss	Communication disconnection at the serial port	Check for a communication cable disconnection to the controller.
30, 31, 32	Network	DPI network loss	See Note 1
33	Ground Fault	Ground fault current level has exceeded programmed value	Check power system and motor and correct if necessary.
			See Note 1
34	Excess Starts/Hr.	Number of starts in a one hour period has exceeded the value programmed	Wait an appropriate amount of time to restart.
			Turn off the Start/Hrs. feature.
35, 36, 37	Power Loss A, B or C (Prestart fault indication)	Missing supply phase	Check for an open line (i.e., blown fuse).



Table 10-1
Fault Display Explanation

Fault Code	Display	Possible Cause	Possible Solution
38	Hall ID	Incorrect power module has been installed	See Note 1
39	NVS Error	Data entry error	See Note 1
41, 42, 43	Line Loss	Line distortion	Check supply voltage for capability to start/stop motor.
		High impedance connection	Check for loose connections on line side or motor side of power wires.

Note 1: Certain faults cannot be corrected at the customer level. Contact the Customer Service Department at KMT Waterjet Systems or an Allen Bradley representative.

Table 10-2
Motor Will Not Start – No Output Voltage to the Motor

Display	Possible Cause	Possible Solution
Fault displayed	See fault description	See Table 10-1 addressing fault conditions.
Display is blank	Control voltage is absent	Check control wiring and correct if necessary.
	Failed control module	Cycle control power. See Note 1
Stopped 0.0 Amps	Pilot devices	Check wiring.
	SMC Enable input is open at terminal 13	Check wiring.
	Input terminals are not wired correctly	Check wiring.
	Control voltage	Check control voltage.
	Failed control module	See Note 1



Table 10-2
Motor Will Not Start – No Output Voltage to the Motor

Display	Possible Cause	Possible Solution
Starting	Two or three power phases are missing	Check power system.

Note 1: Certain faults cannot be corrected at the customer level. Contact the Customer Service Department at KMT Waterjet Systems or an Allen Bradley representative.

Table 10-3
Motor Rotates But Does Not Accelerate to Full Speed

Display	Possible Cause	Possible Solution
Fault displayed	See fault description	See Table 10-1 addressing fault conditions.
Starting	Mechanical problems	Check for binding or external loading and correct. Check motor.
	Inadequate Current Limit setting	See Note 1
	Failed control module	See Note 1

Note 1: Certain faults cannot be corrected at the customer level. Contact the Customer Service Department at KMT Waterjet Systems or an Allen Bradley representative.

Table 10-4
Motor Stops While Running

Display	Possible Cause	Possible Solution
Fault displayed	See fault description	See Table 10-4 addressing fault conditions.
Display is blank	Control voltage is absent	Check control wiring and correct if necessary.
	Failed control module	See Note 1



Table 10-4
Motor Stops While Running

Display	Possible Cause	Possible Solution
Stopped 0.0 Amps	Pilot devices	Check control wiring and correct if necessary.
	Failed control module	See Note 1
Starting	Two or three power phases are missing	Check power system.
	Failed control module	See Note 1

Note 1: Certain faults cannot be corrected at the customer level. Contact the Customer Service Department at KMT Waterjet Systems or an Allen Bradley representative.

Table 10-5
Miscellaneous Situations

Situation	Possible Cause	Possible Solution
Motor current and voltage fluctuates with steady load	Motor	Verify type of motor as a standard squirrel cage induction motor.
	Erratic loads	Check load conditions.
Erratic operation	Loose connections	Shut off all power to controller and check for loose connections.
Accelerates too fast	Starting time	See Note 1
	Initial torque	
	Current limit setting	
	Kickstart	
Accelerates too slow	Starting time	See Note 1
	Initial torque	
	Current limit setting	
	Kickstart	



Table 10-5
Miscellaneous Situations

Situation	Possible Cause	Possible Solution
Fan does not operate	Wiring	Check wiring and correct if necessary.
	Failed fan(s)	See Note 1
Motor overheats	Duty cycle	See Note 1
Motor short circuit	Winding fault	Identify fault and correct.
		Ensure power terminals are secure.
		See Note 1

Note 1: Certain faults cannot be corrected at the customer level. Contact the Customer Service Department at KMT Waterjet Systems or an Allen Bradley representative.



SECTION 11

SPECIFICATIONS

11.1 Overview

A comprehensive listing of specifications for the SL-V 150 and 200 *Plus* are provided in this section.

Table 11-1
SL-V 150 and 200 *Plus*

Model	Motor Horsepower Rating	
	HP	Kw
SL-V 150	150	112
SL-V 200	200	150

11.2 Installation Specifications

Environment

Installation location	Indoors
Air borne dust/contaminants	Minimal
Ambient temperature	
Minimum storage	36° F (2° C)
Minimum operating	40° F (5° C)
Maximum operating	100° F (38° C)
Maximum relative humidity* (<i>at maximum operating temperature</i>)	95%

***Note:** When the relative humidity is above 50%, the oil in the reservoir should be checked frequently for water content.

Sound Level

Sound level [dB(A)]	84.5
---------------------	------



Equipment Dimensions and Weights

Horsepower	Length	Width	Height	Weight
150-200 HP	90.75" (2,305 mm)	66.75" (1,695 mm)	70.00" (1,778 mm)	8,820 lbs (4,000 kg)*
Redundant Model				
150-200HP				9,220 lbs (4,182 kg)*

** Note: When the hydraulic reservoir is full. Subtract 1,000 lbs (454 kg) if the reservoir is dry.*

Service Connections

	Connection	Height
Drain	1/2" NPT	10.75" (273 mm)
Cutting Water Out	3/4" NPT	14.75" (375 mm)
Cooling Water In	1/2" NPT	18.75" (476 mm)
Cooling Water Out	1/2" NPT	22.75" (578 mm)
Plant Air In	1/4" NPT	26.75" (679 mm)
Cutting Water Out	9/16" HP	32.78" (833 mm)

All service connections are made on the rear bulkhead of the machine. The intensifier requires two incoming water sources, cooling water and cutting water; two drain lines, cooling water and wastewater; a high pressure discharge line, and an air supply line.

Plant Air

The facility compressed air connection should provide clean, dry air regulated to 85 psi (5.9 bar). Air usage is minimal, normally less than 1 scf/m.

The following table provides specifications for each ISO air quality classification. KMT recommends adherence to Quality Class 4.

Table 11-2
ISO Air Quality Classifications

ISO Quality Class	Maximum Particle Size (microns)	Maximum Pressure Dew Point (water @ 100 psi)	Maximum Oil Content (Mg/m ³)
1	0.1	-94° F (-60° C)	0.01
2	1	-40° F (-40° C)	0.1
3	5	-4° F (-20° C)	1
4	15	+38° F (+3° C)	5
5	40	+45° F (+7° C)	25
6	--	+50° F (+10° C)	--

11.3 Water Specifications

Cutting Water Supply (Low Pressure Water System)

	150 HP	200 HP
Maximum consumption	12.0 gpm (45.5 L/min)	16.0 gpm (60.6 L/min)
Minimum inlet water pressure	35 psi (2.4 bar) flowing	
Maximum inlet water pressure	80 psi (5.5 bar)	
Maximum booster pump outlet water pressure	120 psi (8.3 bar)	
Booster pump factory set inlet pressure	58 psi (4 bar)	
Booster pump factory set outlet pressure	120 psi (8.3 bar)	
Optimum inlet water temperature	65° F (18° C)	
Maximum inlet water temperature	85° F (29° C)	
Low inlet water pressure shutdown	30 psi (2 bar)	
Low booster pressure shutdown	60 psi (4 bar)	
Booster pump overheat shutdown	128° F (53° C)	



Cooling Water Supply (Recirculation System)

	150 HP	200 HP
Maximum consumption at 75° F (24° C)	7.0 gpm (26.5 L/min)	9.0 gpm (34.1 L/min)
Total heat rejection	26.0 HP (19.4 kW)	35.0 HP (26.1 kW)
Oil reservoir capacity	125 gal (473 L)	
Oil remaining at low oil level shutdown	108 gal (409 L)	
Minimum operating oil temperature	60° F (15° C)	
Optimum operating oil temperature	115° F (46° C)	
Hot oil shutdown (maximum operating oil temperature)	150° F (65.5° C)	
Minimum inlet cooling water pressure	35 psi (2.4 bar)	
Maximum inlet cooling water pressure	100 psi (6.9 bar)	
Oil filtration rating (Beta filtration rating)	$\beta_{10} \geq 100^*$	
Fluid cleanliness rating (ISO fluid cleanliness rating))	17/14**	
Nominal oil filter pressure	35 psi (2.4 bar)	
Recirculation pump shutdown	30 psi (2 bar)	
Recommended oil type		
General service	Mobil DTE 26, Grade 68 Conoco Hydroclear™ multi-purpose R&O	
Food service	Fuchs/Geralyn AW68	

* **Note:** For each particle per milliliter downstream of the filter greater than 10 microns, there are 100 particles per milliliter larger than 10 microns upstream of the filter.

****Note:** Indicates ISO 4406 range numbers for maximum permissible number of particles per milliliter, greater than 5 and 15 microns.

17 <1,300 particles per milliliter, >5 microns

14 <160 particles per milliliter, >15 microns

Water Quality Standards

The quality of the inlet cutting water supply is one of the most important factors affecting component life and performance. Water treatment requirements can be determined by a water analysis.

The cutting water supply must meet the following standards. A high concentration of dissolved solids, especially calcium, silica and chlorides will affect high pressure component life.



Table 11-3
Water Quality Standards

Constituent (mg/l)	Minimum Requirement	Better	Best
Alkalinity	50	25	10
Calcium	25	5	0.5
Carbon Dioxide	0	0	0
Chloride	100	15	1
Free Chlorine	1	1	0.05
Iron	0.2	0.1	0.01
Magnesium as Mg	0.5	0.1	0.1
Manganese as Mn	0.1	0.1	0.1
Nitrate	25	25	10
Oxygen	2	1	0.1
Silica	15	10	1
Sodium	50	10	1
Sulfate	25	25	1
TDS*	200	100	5**
Total Hardness	25	10	1
pH	6.5-8.5	6.5-8.5	6.5-8.5
Turbidity (NTU)	5	5	1

* **Note:** Total dissolved solids

****Note:** Do not reduce the TDS beyond this amount or the water will be too aggressive.

Table 11-4
Water Impurities

Constituent	Chemical Formula	Comments
Alkalinity	Bicarbonate (HCO ₃) Carbonate (CO ₃) Hydrate (OH), expressed as CaCO ₃	Acid neutralizing capacity of water. Foaming and carryover of solids, causes embrittlement of steel, can produce CO ₂ , a source of corrosion.
Calcium	Ca	When dissolved makes water hard; contributes to the formation of scale.
Carbon Dioxide	CO ₂	Causes corrosion
Chloride	Cl	Adds to solid content and increases corrosive character of water; in relative percentage presence with oxygen induces stress corrosion cracking.
Free Chlorine	Cl ₂	Oxidizing agent; can attack elastomeric seals and damage reverse osmosis (RO) membranes.
Iron	Fe ⁺⁺ (ferrous) Fe ⁺⁺⁺ (ferric)	Discolors water or precipitation; source of scale and erosion.
Magnesium as Mg		When dissolved makes water hard; contributes to the formation of scale.
Manganese as Mn	Mn ⁺⁺	Discolors water or precipitation; source of scale and erosion.
Nitrate	NO ₃	Adds to solid content; effect is not generally significant industrially.
Oxygen	O ₂	Causes corrosion
Silica	SiO ₂	Causes scale
Sodium	Na	Found naturally; introduced to water in the ion exchange water softening process.
Sulfate	SO ₄	Adds to solid content; combines with calcium to form calcium sulfate scale.
TDS		Measure of the total amount of dissolved matter in water.
Total Hardness	CaCO ₃	Sum of all hardness constituents in water; typically expressed as their equivalent concentration of calcium carbonate; primarily due to calcium and magnesium in solution, but may include small amounts of metal. Carbonate hardness is usually due to magnesium and calcium bicarbonate; non-carbonate hardness is due to sulfates and chlorides.
pH		Intensity of the acidic or alkaline solids in water; pH scale runs from 0, highly acidic, to 14, highly basic; with 7 being neutral.

11.4 Electrical Specifications

Electrical System

Motor type	TEFC (Totally Enclosed Fan Cooled)
Controls	
Voltage	24 volts DC
Power supply	10 amps DC

Ampacity and Power Voltage Requirements

Power Voltage	Motor Horsepower	Full Load Amps	Circuit Breaker Amps
460/3/60	150	166	225
400/3/50	200	259	275
460/3/60	200	225	350
575/3/50-60	200	198	350

11.5 Hydraulic and High Pressure Water System Specifications

Hydraulic System

Maximum operating pressure	2,650 psi (183 bar)
Main system relief valve	2,970 psi (205 bar)

High Pressure Water System

	150 HP	200 HP
Maximum flow rate @ 60,000 psi (4,137 bar)	2.7 gpm (10.2 L/min)	3.6 gpm (13.6 L/min)
Plunger diameter	1.125" (29 mm)	
Piston diameter	5.50" (139.7 mm)	
Intensification ratio	23:1	
Minimum outlet pressure	5,000 psi (345 bar)	
Maximum outlet pressure	60,000 psi (4,137 bar)	

High Pressure Water System

Pneumatic Control Valve

Maximum water pressure	60,000 psi (4,137 bar)
Minimum air pressure	85 psi (5.9 bar)
Maximum air pressure	100 psi (6.9 bar)
Maximum flow rate	1.0 cfm (0.028) m ³ /min

Orifice Capacity

The following tables provide horsepower requirements for some of the more popular orifices.

Table 11-5
Single Orifice Diameter

Model	Motor Horsepower Rating		Maximum Operating Pressure	Maximum Single Orifice Diameter (at full pressure)
	HP	Kw		
SL-V 150	150	112	60,000 psi (4,137 bar)	0.023 inch (0.584 mm)
SL-V 200	200	150	60,000 psi (4,137 bar)	0.026 inch (0.660 mm)

Table 11-6
Horsepower Requirements

Orifice Size inches (mm)	45,000 psi (3,103 bar)	50,000 psi (3,447 bar)	55,000 psi (3,792 bar)	60,000 psi (4,137 bar)
0.003 (0.076)	1.7	2.0	2.3	2.6
0.004 (0.102)	3.0	3.5	4.0	4.6
0.005 (0.127)	4.6	5.4	6.2	7.1
0.006 (0.152)	6.7	7.8	9.0	10.2
0.007 (0.178)	9.1	10.6	12.2	13.9
0.008 (0.203)	11.8	13.9	16.0	18.2
0.009 (0.229)	15.0	17.5	20.2	23.0
0.010 (0.254)	18.5	21.6	25.0	28.5
0.011 (0.279)	22.4	26.2	30.2	34.4
0.012 (0.305)	26.6	31.2	36.0	41.0



**Table 11-6
Horsepower Requirements**

Orifice Size inches (mm)	45,000 psi (3,103 bar)	50,000 psi (3,447 bar)	55,000 psi (3,792 bar)	60,000 psi (4,137 bar)
0.013 (0.330)	31.2	36.6	42.2	48.1
0.014 (0.356)	36.2	42.4	48.9	55.8
0.015 (0.381)	41.6	48.7	56.2	64.0
0.016 (0.406)	47.3	55.4	63.9	72.8
0.017 (0.432)	53.4	62.6	72.2	82.2
0.018 (0.457)	59.9	70.1	80.9	92.2
0.019 (0.483)	66.7	78.1	90.1	102.7
0.020 (0.508)	73.9	86.6	99.9	113.8
0.021 (0.533)	81.5	95.4	110.1	125.5
0.022 (0.559)	89.4	104.8	120.9	137.7
0.023 (0.584)	97.8	114.5	132.1	150.5
0.024 (0.610)	106.4	124.7	143.8	163.9
0.025 (0.635)	115.5	135.3	156.1	177.8
0.026 (0.660)	124.9	146.3	168.8	192.3
0.027 (0.686)	134.7	157.8	182.0	207.4
0.028 (0.711)	144.9	169.7	195.8	223.0

The horsepower requirements for operating multiple orifices are determined by adding the requirements in Table 11-6 for each orifice. Examples are shown below.

Orifice Size inches (mm)	Number of Orifices	Operating Pressure	Calculation	Total Horsepower
0.013 (0.330)	3	55,000	3 x 42.2	126.6
0.015 (0.381)	1	50,000	48.7 + 86.6	155.3
0.020 (0.508)	1			

Torque Specifications

Measurements are made with lubricated components and a properly calibrated torque wrench. Inconsistencies in wrench settings, lubrication and technique may not produce a leak free seal. If leakage occurs, the torque can be increased to seal the components. However, **do not exceed the recommended torque value by more than 15 percent**. If leakage persists, there is a component problem.



Excessive torque can cause component damage or failure, resulting in potential hazards to equipment and personnel.

Torque Specifications

Hard Seal End Cap	
Jackbolts	8 (7/16") each
1st Stage	Hand Tight
2nd Stage	20 ft-lbs (27 Nm) Crossing Pattern
3rd Stage	32-35 ft-lbs (43-47 Nm)* Crossing Pattern
4th Stage	32-35 ft-lbs (43-47 Nm)* Clockwise Pattern From Bolt 1
Socket Wrench Size	3/8 inch

8-Bolt Crossing Pattern

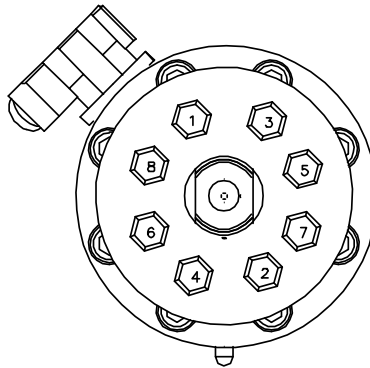

* **Note:** A maximum torque of 38 ft-lbs (51 Nm) is etched on the hard seal end cap. This represents the **maximum** allowable torque, not the recommended torque.



Torque Specifications

Hydraulic Cylinder Head

Socket Head Screws	6 (3/4") each
Torque	170-175 ft-lbs (230-237 Nm)
Hex Key	5/8 inch

Proximity Switch

Socket Head Screws	2 (1/4") each
Torque	140-160 in-lbs (16-18 Nm)
Hex Key	3/16 inch

Stem Mount

Socket Head Screws	4 (3/8") each
Torque	35-40 ft-lbs (47-54 Nm)
Hex Key	5/16 inch

Sealing Head

Discharge Gland Nut	200 ft-lbs (271 Nm)
Poppet Retainer	25-30 in-lbs (2.8-3.4 Nm)
9/16" Inlet Gland Nut	110 ft-lbs (149 Nm)

Pneumatic Control Valve

3/8-inch HP Inlet Gland Nut	50 ft-lbs (68 Nm)
1/4-inch Outlet to Drain	25 ft-lbs (34 Nm)
Pneumatic Actuator	5 ft-lbs (7 Nm)
9/16"-1/4" HP Bushing	110 ft-lbs (149 Nm)

High Pressure Fittings

1/4-inch Gland Nut	25 ft-lb (34 Nm)
3/8-inch Gland Nut	50 ft-lb (68 Nm)
9/16-inch Gland Nut	110 ft-lb (149 Nm)
3/4-inch Gland Nut	120 ft-lb (163 Nm)



SECTION 12 PARTS LIST

12.1 Overview

This section contains a comprehensive list of all standard and optional parts for the 150 horsepower SL-V Plus, maintenance tools, installation and equipment accessories. To facilitate the ordering of replacement parts, item numbers in each table correspond to the identifying numbers in the accompanying figures.

Use the following information to contact the Customer Service Department at KMT Waterjet Systems.

USA

Customer Service Department
KMT Waterjet Systems
PO Box 231
635 West 12th Street
Baxter Springs, KS 66713-0231

Phone (800) 826-9274
Fax (620) 856-2242
Email wj.service@kmtwaterjet.com
wj.parts@kmtwaterjet.com

Europe

Spare Parts Manager
KMT Waterjet Systems GmbH
Wasserstrahl Schneidetechnik
Auf der Laukert 11
D-61231 Bad Nauheim
Germany

Phone +49-6032-997-119
Fax +49-6032-997-271
Email order.spares@kmt-waterjet.com



12.2 Part Nomenclature

The following list explains the abbreviations and numerical sizes used in the following part descriptions.

Abbreviations and Nominal Size Guide

Item	Description
1/4, 9/16, 3/4	Nominal sizes in fractions of an inch
D	Degree
HP or LP	High pressure or low pressure
ID or OD	Inside diameter or outside diameter
JIC	37-degree flared, threaded hydraulic fitting
NO or NC	Normally open or normally closed
NPT	National Pipe Thread, pipe thread and pressure vessel standard
psi or ksi	Pounds per square inch or thousands of pounds per square inch
SAE O-Ring	O-ring threaded port style, Society of Automotive Engineers (SAE) standard
TUV	German pressure vessel code and inspection agency



12.3 Index

Part lists are arranged in the following sequence:

Parts List Index

Table	Description	Part Number	Page	Table	Description	Part Number	Page
12-1	150 HP Intensifier Unit		12-5	12-14	Hydraulic Hose Connections	20426988	12-31
12-2	Intensifier Assembly	20424142	12-7	12-15	Reservoir Assembly	20419549	12-34
12-3	Hydraulic Cartridge Seal	05146584	12-9	12-16	Bulkhead Pipe Assembly	20424900	12-36
12-4	Sealing Head Assembly	80072341	12-10	12-17	Low Pressure Water Filter Assembly	20424926	12-39
12-5	Pneumatic Control Dump Valve	10184760	12-11	12-18	Low Pressure Water Manifold	20443699/20433512	12-41
12-6	Hydraulic Piston Assembly	05146576	12-13	12-19	Gauge Assembly	20441302/20443707	12-43
12-7	High Pressure Water Assembly	20424134	12-15	12-20	Cover Assembly	20424027	12-45
12-8	Manifold Assembly	20420858	12-18	12-21	Electrical Assembly	20467862	12-47
12-9	Heat Exchanger Assembly	20441211	12-20	12-22	Electrical Controller Assembly	20430457	12-49
12-10	Hydraulic Power Package	20449335	12-22	12-23	Controls Subassembly	20424258	12-51
12-11	Hydraulic Manifold Assembly	20423095	12-25	12-24	Starter/Controller Configuration	20467768	12-53
12-12	Motor/Pump Assembly, 5 HP	20443394	12-27	12-25	Redundant Kit	20428267	12-56
12-13	Motor/Pump Assembly, 1.5 HP	20443376	12-29				



Parts List Index

Table	Description	Part Number	Page	Table	Description	Part Number	Page
12-26	High Pressure Tube Coning Tools		12-59	12-36	Nozzle Tubes		12-78
12-27	High Pressure Tube Threading Tools		12-60	12-37	Autoline™ Abrasive Nozzle Assembly		12-80
12-28	Maintenance Tools and Lubricants		12-61	12-38	Autoline II™ Abrasive Nozzle Assembly		12-81
12-29	Focusing Tubes		12-63	12-39	Autoline™ Diamond Orifice		12-82
12-30	Standard Sapphire Orifice		12-65	12-40	Autoline™ Sapphire Orifice		12-82
12-31	Standard Diamond Orifice		12-65	12-41	Pneumatic Control Valve, NC		12-83
12-32	High Pressure Fitting and Valve Assemblies		12-66	12-42	Pneumatic Cylinder Assembly, NC		12-84
12-33	Bulk High Pressure Tubing		12-69	12-43	Pneumatic Control Valve, NO		12-85
12-34	High Pressure Filter Assemblies		12-70	12-44	Pneumatic Cylinder Assembly, NO		12-86
12-35	High Pressure Swivel Joints		12-72				



Table 12-1
SL-V 150 Horsepower Intensifier Unit

Item	Part Number	Description	Quantity	Item	Part Number	Description	Quantity
1	20449335	Hydraulic Power Package	1	11	20428267	Redundant Kit	1
2	20423952	Frame Assembly	1	12	20441302	Gauge Assembly, Redundant	1
3	20424134	High Pressure Piping	1		20443707	Gauge Assembly, Non-Redundant	
4	20467862	Electrical Assembly	1	13	20443376	Motor/Pump Assembly, 1.5 HP	1
5	20424900	Bulkhead Pipe Assembly	1	14	2042739220	Program Flashcard	1
6	20419549	Reservoir Assembly	1	15	2042662640	EEPROM	1
7	20443394	Motor/Pump Assembly, 5 HP	1	16	20443699	Manifold Assembly, LP Water, Redundant	1
8	20426988	Hydraulic Hose Connections	1		20433512	Manifold Assembly, LP Water, Non-Redundant	
9	20424027	Cover Assembly	1	17	20441211	Heat Exchanger	1
10	20449309	Decal Package, 150R	1	18	95670972	Lock Washer, .38	8
	20467785	Decal Package, 150D		19	05091954	Button Head Screw, 3/8-16 x 1	8

Figure 12-1: SL-V 150 Horsepower Intensifier Unit

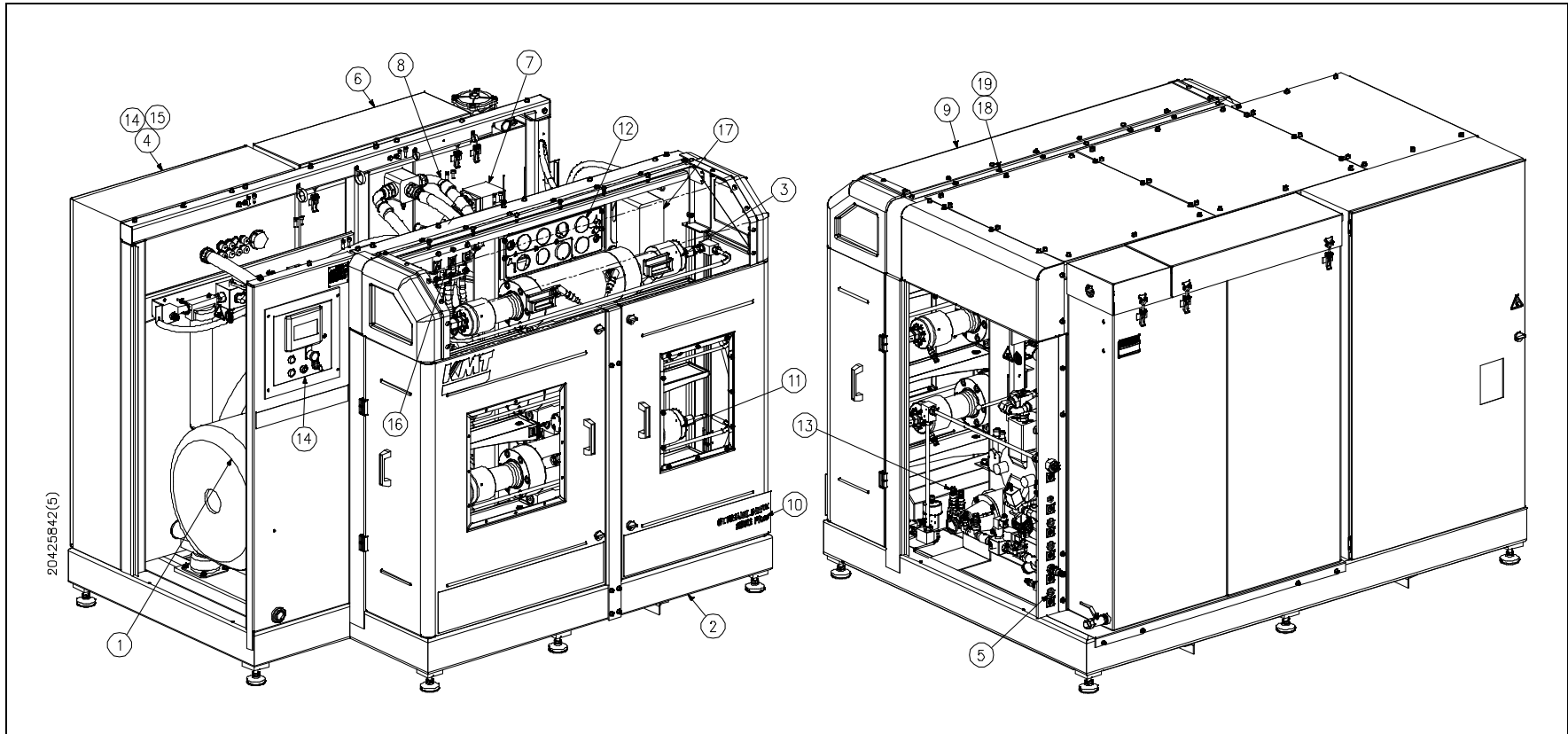



Table 12-2
Intensifier Assembly
20424142

Item	Part Number	Description	Quantity	Item	Part Number	Description	Quantity
1	20473479	HP Cylinder	2	14	05144514	Hydraulic Cylinder	1
2	05144506	Ceramic Plunger	2	15	05120092	Backup Ring, 5.25 x 5.50	2
3	80072341	Sealing Head Assembly	2	16	10074771	O-Ring, 5.25 x 5.50 x .13	2
4	20416445	Hydraulic Cylinder Head	2	17	20413955	Socket Head Screw, 3/4-16 x 3-1/4	12
5	05149711	HP Seal Assembly	2	18	05130224	Proximity Switch, 20-250V AC/DC	2
6	05144597	Spacer, Sealing Head	2	19	95119012	Socket Head Screw, 1/4 x 20 x 1	4
7	49838220	HP Cylinder Nut, HSEC	2	20	05146576	Piston Assembly	1
8	05146584	Hydraulic Cartridge Seal Assembly	2	21	05144183	Spacer, Proximity Switch	2
9	05145099	Bushing Retainer Flange	2				
10	05144555	Liner, HP Cylinder	2				
11	10074920	O-Ring, 1.75 x .94 x .09	4				
12	80070352	Jackbolt, 7/16-20 x 2.31	16				
13	05034798	Retaining Ring	2				

Figure 12-2: Intensifier Assembly

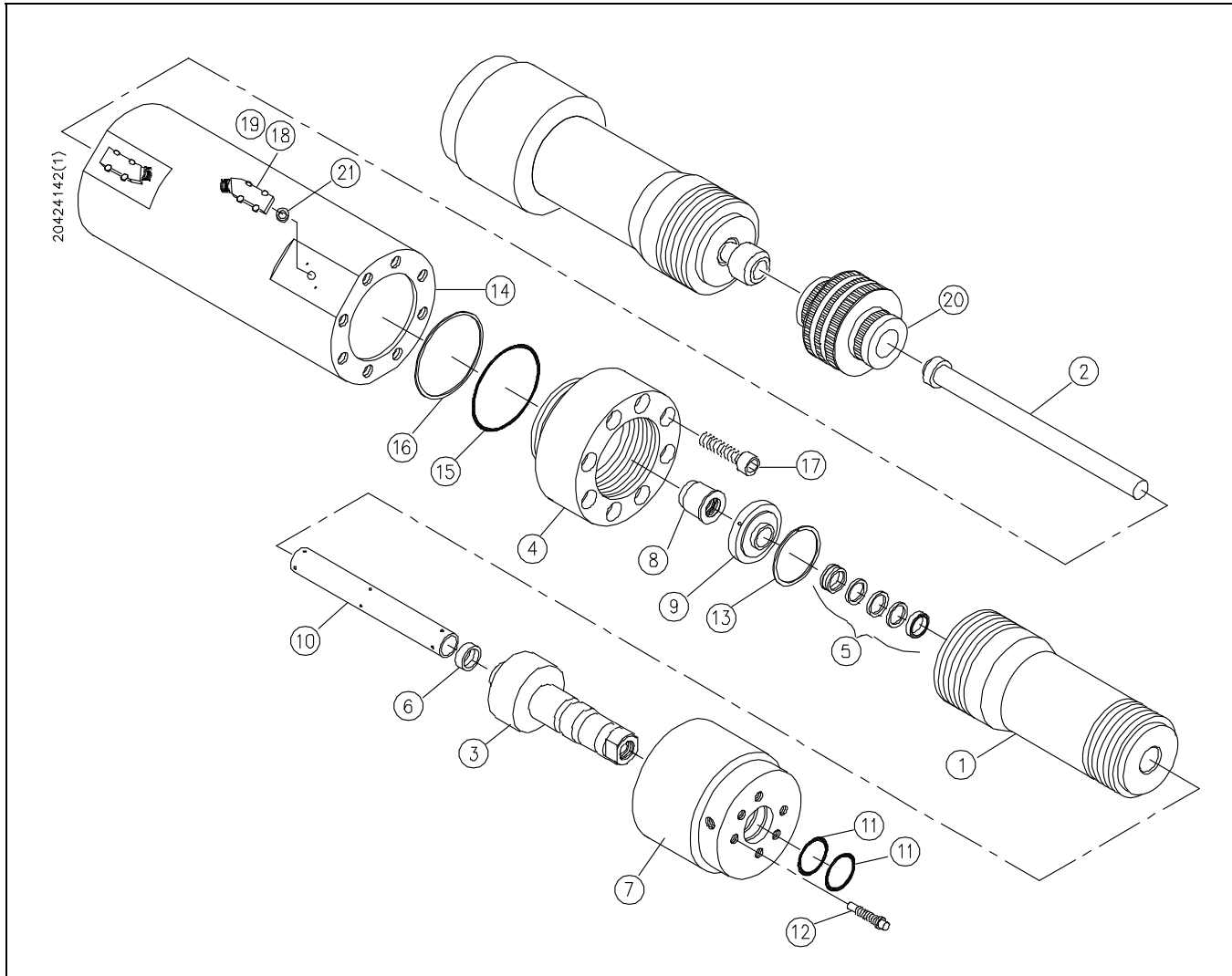

Table 12-3
Hydraulic Cartridge Seal
05146584

Item	Part Number	Description	Quantity
1	05144530	Seal Bushing	1
2	10142032	Packing Ring, 1.38 x 1.13 x .25	2
3	10145431	O-Ring, 1.44 x 1.63 x .09	1
4	05116140	Backup Ring, 1.44 x 1.63	1
5	10168912	O-Ring, 1.25 x 1.38 x .06	1
6	05116124	O-Ring, 1.50 x 1.63 x .06	1
7	05116132	U-Cup Seal, 1.13 x 1.38 x .13	1
	80085061	Rebuild Kit	
		Includes Items 2-7	

Figure 12-3: Hydraulic Cartridge Seal

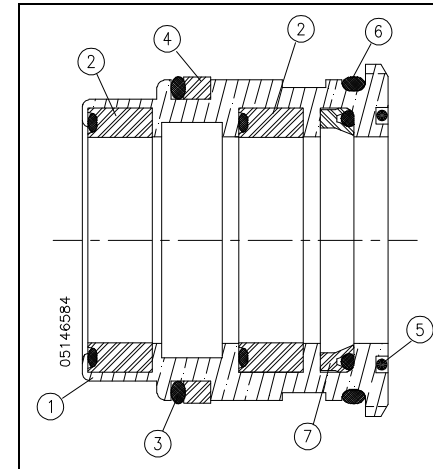
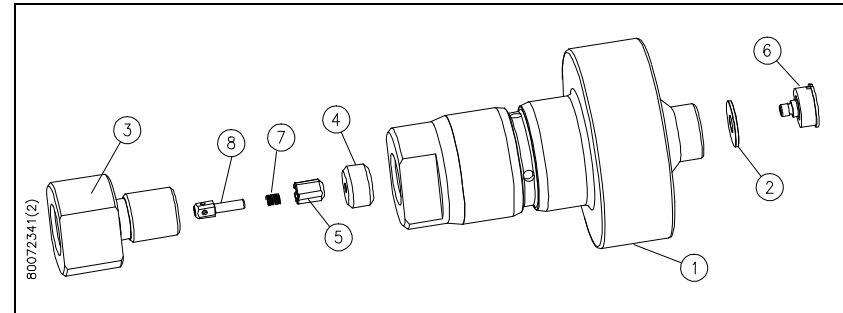

Table 12-4
Sealing Head Assembly
80072341

Item	Part Number	Description	Quantity
1	80071293	Sealing Head Body	1
2	05119680	Inlet Poppet Valve	1
3	05116595	Gland Nut	1
4	05116579	Seat	1
5	05116603	Discharge Poppet Valve	1
6	05119698	Poppet Retainer	1
7	05147863	Compression Spring	1
8	05119839	Poppet Pin	1

Figure 12-4: Sealing Head Assembly



80084403 Rebuild Kit
Includes Items 4, 5, 7 and 8



Table 12-5
Pneumatic Valve/Actuator Assembly, Normally Open
10184760

Item	Part Number	Description	Quantity	Item	Part Number	Description	Quantity
1	10189181	Valve Body	1		10189553	Actuator Assembly, Normally Open	
2	10178697	Valve Seat	1	6	BV401184	Pneumatic Cylinder	1
3	20435636	Valve Stem	1	7	BV601184	Cylinder Head	1
4	10188233	Backup Ring, Brass	1	8	BV501184	Piston	1
5	20428052	Seal Assembly	1	9	10187250	Backup Ring, SST	1
				10	10074714	O-Ring, 2.44 x 2.63 x .09	1
				11	10074565	O-Ring, 2.25 x 2.38 x .06	2

05116017 Rebuild Kit

Includes Items 2, 3, 4, 5, 10 and 11

Figure 12-5: Pneumatic Control Dump Valve

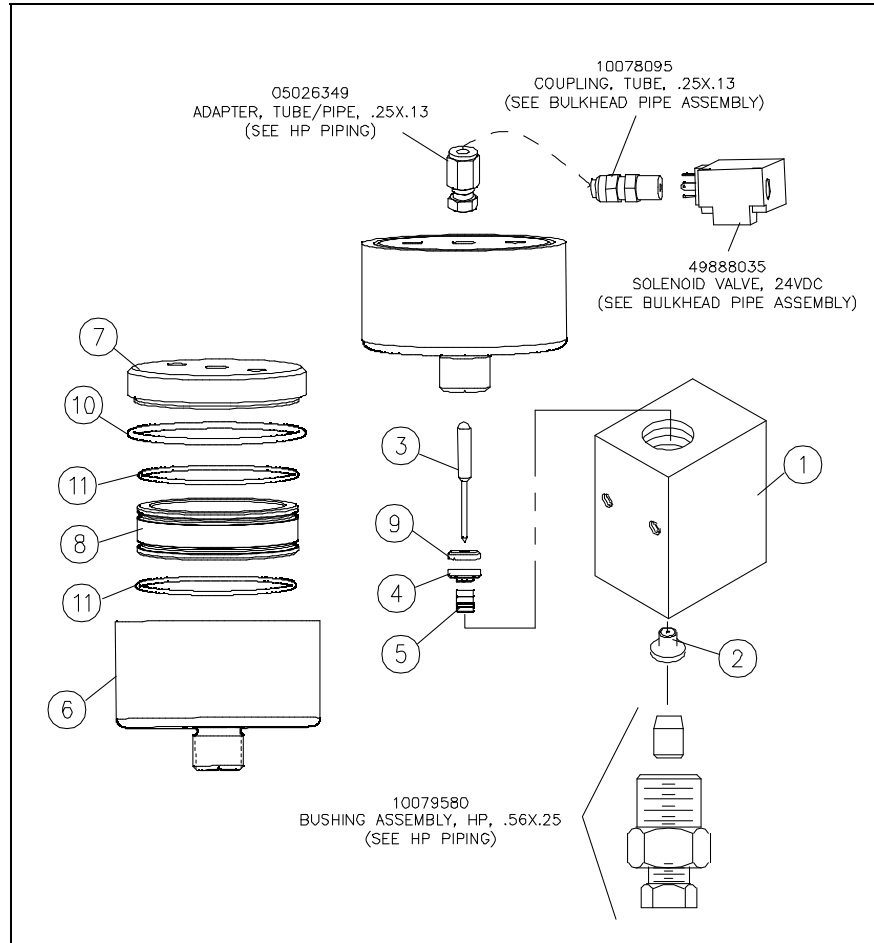



Table 12-6
Hydraulic Piston Assembly
05146576

Item	Part Number	Description	Quantity
1	05144589	Hydraulic Ram Piston, 5.50	1
2	05074380	Plunger Retainer Pin, Clevis	12
3	05049887	Set Screw, Socket, 3/8-16 x 3/8	2
4	10148757	Check Valve	2
5	49877509	Adhesive, Thread Locker	--
6	05130216	Flat Snap Ring, .032 x .375 x 2.20	2
7	05146568	Backup Ring, 1.50 x 1.75 x .125	2
8	10074821	O-Ring, 1.50 x 1.75 x .13	2
9	05120118	Seal Assembly	1
10	05120100	Bearing Ring	2
	80085079	Rebuild Kit	
		Includes Items 4, 6, 7, 8, 9 and 10	

Figure 12-6: Hydraulic Piston Assembly

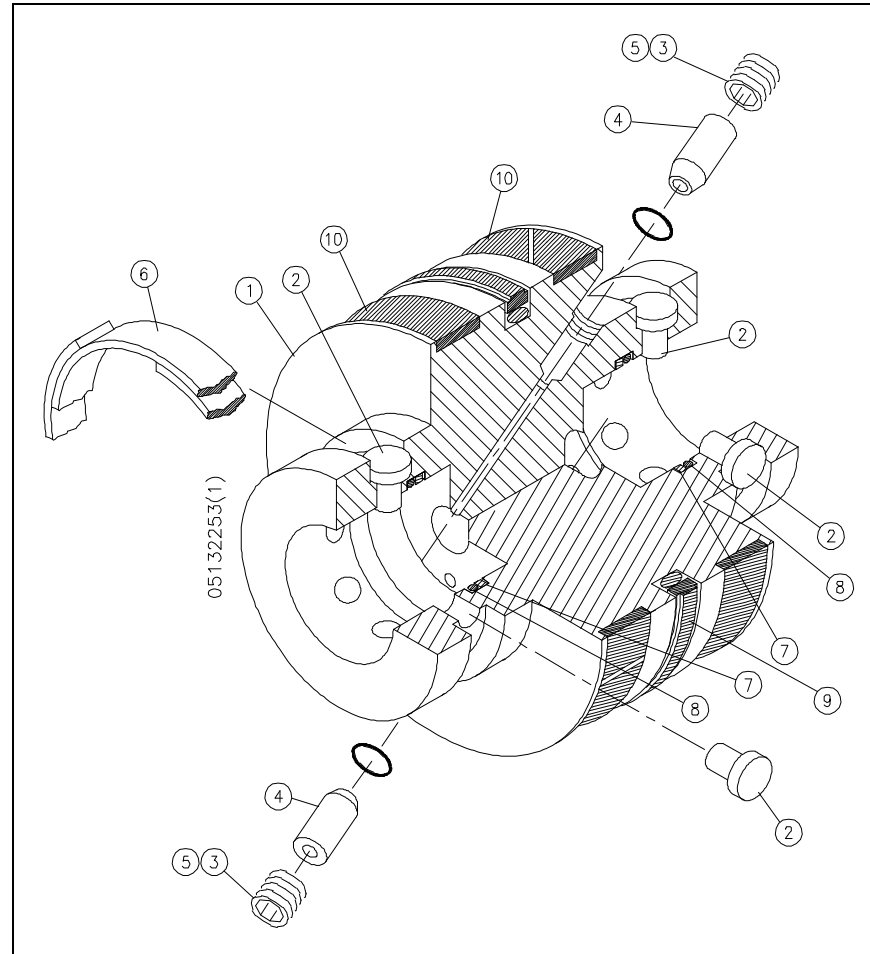



Table 12-7
High Pressure Water Assembly
20424134

Item	Part Number	Description	Quantity	Item	Part Number	Description	Quantity
1	20424142	Intensifier Topworks	2	20	10079457	Bushing, HP, .56 x .38	1
2	20420858	Hydraulic Manifold Assembly	2	21	10079705	Coupling, HP, .56 x .56	1
3	10118206	O-Ring, 1.31 x 1.56 x .13	4	22	10184760	Pneumatic Valve/Actuator Assembly, NO	1
4	95688743	Lock Washer, .38	16	23	10079580	Bushing, HP, .56 x .25	2
5	05041058	Socket Head Screw, 3/8-16 x 2-1/4	16	24	10078913	HP Gland, Anti-Vibration, .38	1
6	95413696	Lock Washer, .50	26	25	10078715	HP Collar, .38	1
7	95229852	Socket Head Screw, 1/2-13 x 1-1/4	12	26	05026349	Adapter, Tube/Pipe, .25 x .13	1
8	20437206	Directional Control Valve, 24V DC	2	28	10069326	HP Tube, .56 x 4.0	9
9	95688750	Lock Washer, .50	12	31	10078459	HP Gland, .25	1
10	95055059	Socket Head Screw, 1/2-13 x 2-1/2	12	33	10078426	HP Collar, .25	1
11	20413302	Attenuator Assembly, 3.0 L	1	34	20434918	HP Tube, .56 x 20.88	1
12	10079119	HP Collar, .56	3	35	49888746	HP Tube, .56 x 13.58	1
13	10078608	HP Gland, .56	5	36	10094704	HP Tube, .38 x 3.0	1
14	10078525	Elbow, HP, .56 x .56	5	37	20427038	HP Tube, Bent, .25	1
15	10079465	Tee, HP, .56	7	38	20429015	HP Tube, .56 x 27.13	1
16	10078889	2-Way Valve	2	39	20429255	HP Tube, Bent, .56	2
17	20414995	HP Tube, .56 x 8.93	1	40	80086135	HP Tube, .25 x 2.13	1
18	20424835	HP Tube, .56 x 21.25	1	41	20440410	Housing, Attenuator, 3.0 L	1
19	49889249	HP Tube, .56 x 7.0	1	42	95228995	Socket Head Screw, 3/8-16 x 3/4	4



Table 12-7
High Pressure Water Assembly
20424134

Item	Part Number	Description	Quantity	Item	Part Number	Description	Quantity
43	95670972	Lock Washer, .38	4	49	10090595	HP Tube,.56 x 4.50	1
44	95660957	Flat Washer, .38	4	50	20441180	Bracket, Attenuator Housing	2
45	05131347	Ferrule, .50	28	51	95273876	Flat Washer, .50	10
46	05086905	Conduit, Flexible, .63	284.0"	52	95383790	Socket Head Screw, 1/2-13 x 1	10
47	20434884	Bracket, Attenuator	1	53	05103023	PED Decal	1
48	10078772	Plug, HP, .56	2	54	10140986	HP Tube, .56 x 5.0	1

Figure 12-7: High Pressure Water Assembly

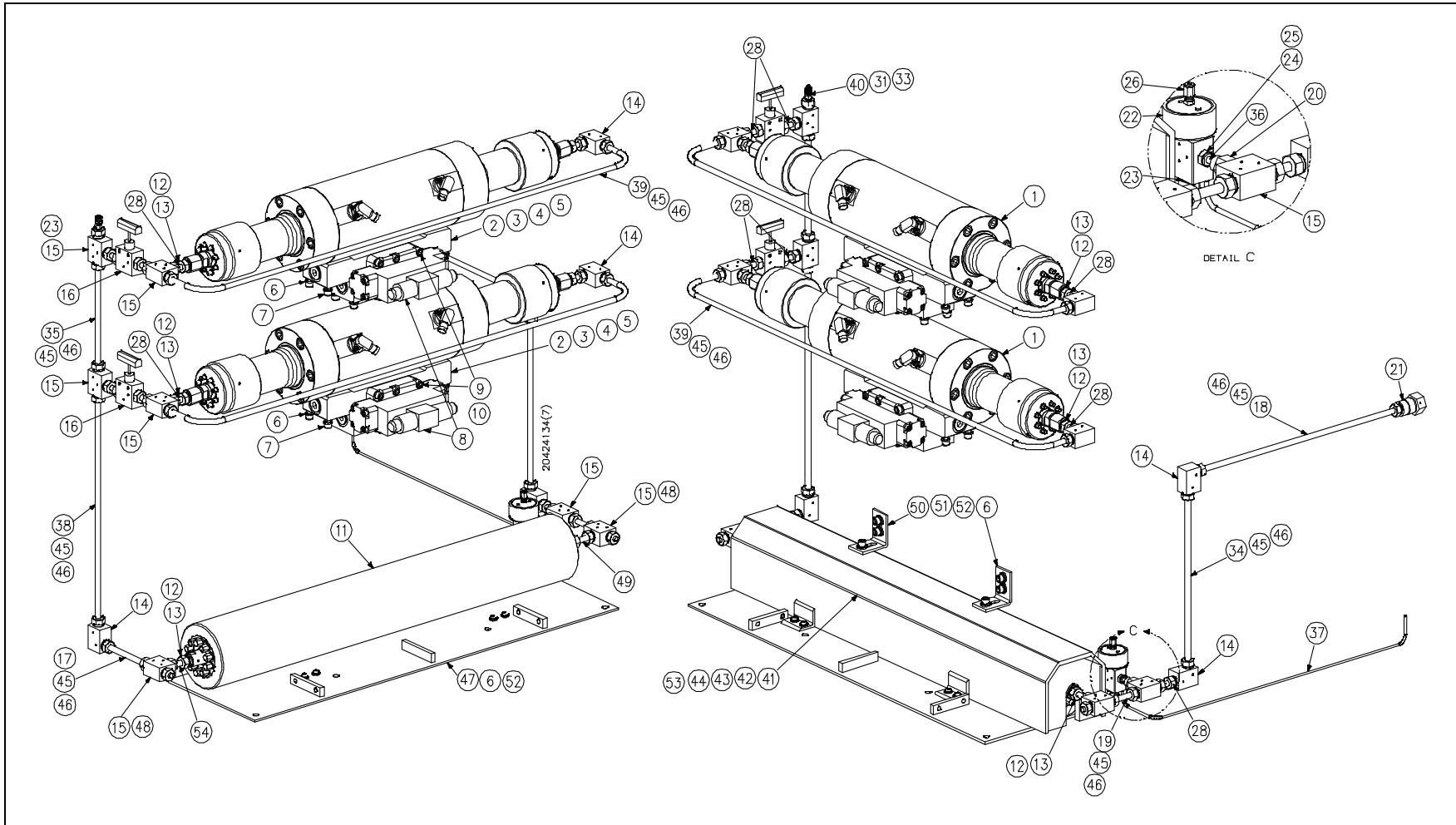



Table 12-8
Manifold Assembly
20420858

Item	Part Number	Description	Quantity
1	20419787	Manifold	1
2	49889751	Plug, ORB, 1.0	3
3	10192813	Plug, ORB, .25	1
4	10144749	Adapter, JIC/ORB, .25 x .25	1

Figure 12-8: Manifold Assembly

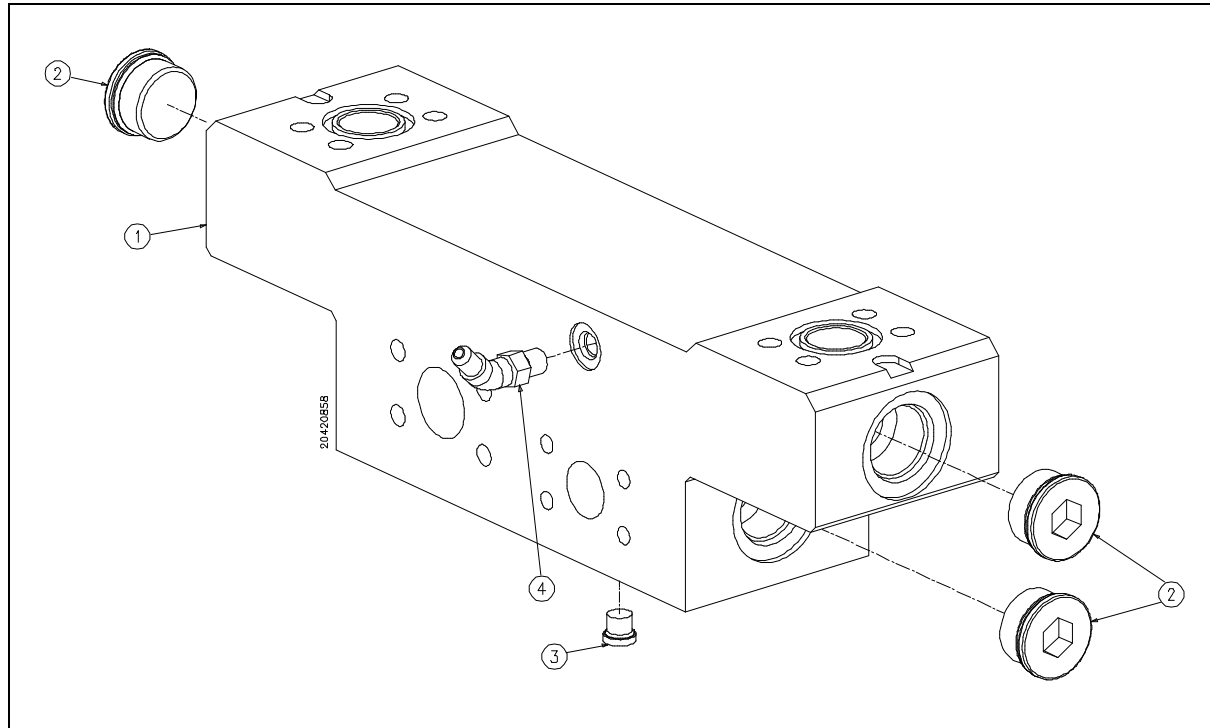



Table 12-9
Heat Exchanger Assembly
20441211

Item	Part Number	Description	Quantity
1	20438031	Heat Exchanger	1
2	20437543	Coupling, Pipe, 1.25 x .75	2
3	20437552	Coupling, Pipe, 1.25 x 1.25	2
4	05104203	Adapter, JIC/Pipe, 1.25 x 1.25	1
5	10117919	Adapter, Pipe/JIC, .75 x .50	2
6	10173805	Adapter, Hose/JIC, .50 x .50	2
7	95423646	Hex Nut, 3/8-16	8
8	10069714	Flat Washer, .38	4
9	49879505	Adapter, JIC/Pipe, 1.25 x 1.25	1

Figure 12-9: Heat Exchanger Assembly

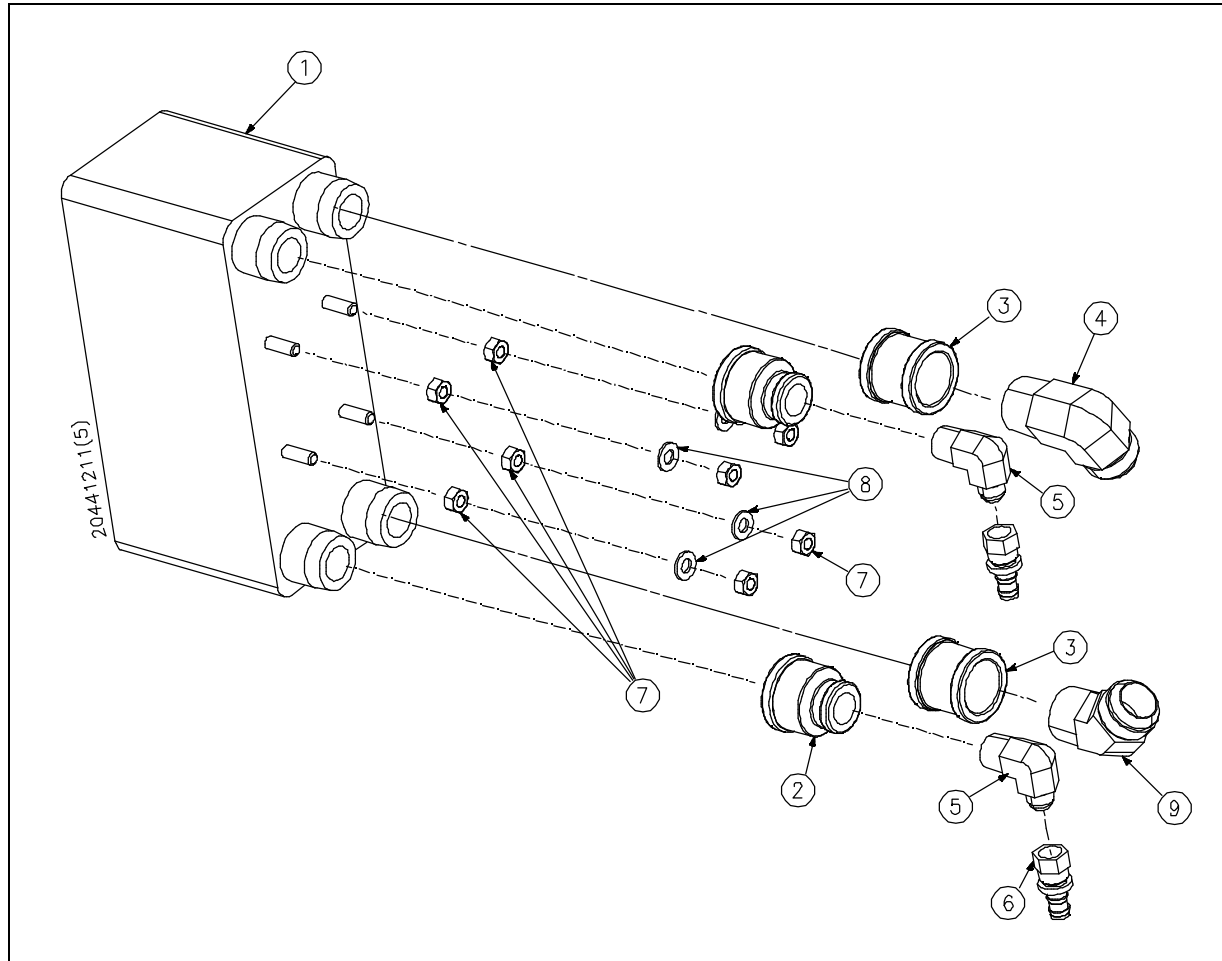



Table 12-10
Hydraulic Power Package
20449335

Item	Part Number	Description	Quantity	Item	Part Number	Description	Quantity
1	20449327	Electric Motor, 150 HP	1	13	49833072	Lock Washer, .63	4
2	20419500	Motor Mount	2	14	95296281	Hex Head Screw, 3/4-10 x 2	4
3	95688735	Lock Washer, .75	8	15	05106984	Adapter, Hose/Flange, 2.50 x 2.50	2
4	10075877	Hex Head Screw, 3/4-10 x 2-3/4	4	16	05085758	Adapter, ORB/JIC, .38 x .25	2
5	20428835	Vibration Isolation Base	4	17	10091163	Adapter, JIC/ORB, .75 x .75	2
6	20426658	Coupling, Motor Shaft	1	18	20423095	Manifold Assembly	2
7	20426634	Coupling, Flexible Insert	1	19	80071087	Proportional Pressure Valve	2
8	20428999	Flange, Motor/Pump	1	20	49882087	O-Ring, 1.88 x 2.13 x .13	2
9	95688719	Lock Washer, .63	8	21	20432331	Socket Head Screw, M16 x 2 x 50MM	4
10	95897294	Hex Head Screw, 5/8-11 x 1-1/2	8	22	95688750	Lock Washer, .50	8
11	20426676	Coupling, Pump Shaft	1	23	05061148	Socket Head Screw, 1/2-13 x 5	8
12	20431992	Hydraulic Pump Assembly	1	24	05051214	Hydraulic Hose Assembly, .25 x 39.0	2
	20421355	Hydraulic Pump, W/Thru Shaft	1	25	10069714	Flat Washer, .38	16
	20421363	Hydraulic Pump, W/O Thru Shaft	1	26	95416319	Hex Head Screw, 3/8-16 x 1	16
	20432620	Coupling, Pump Shaft	1	27	95750394	Lock Washer, .38	16
	10074896	O-Ring, 6.0 x 6.25 x .13	1	28	49872245	Split Flange, 2.50	2
	20431563	Socket Head Screw, M16 x 2 x 35MM	4	29	10091510	Arrow Decal	1
	49892359	Lock Washer, M16	4	Ref 1	49882095	O-Ring, 2.75 x 3.0 x .13	--
	05139639	Bushing, ORB, M14 x .25	2				



Table 12-10
Hydraulic Power Package
20449335

Item	Part Number	Description	Quantity	Item	Part Number	Description	Quantity
	20443683	Redundant Models Only					
30	05131941	Coupling, ORB, 1.0 x 1.0	2	34	20432000	Hydraulic Hose Assembly, 1.0 x 13.0	1
31	20419573	3-Way Valve	2	36	20436899	Decal, Position C/A	1
32	20452416	Adapter, FSOR/ORB, 1.25 x 1.0	2	37	20436883	Decal, Position C/B	1
33	20431407	Tee, FSOR/FSOR, 1.0 x 1.0	1	38	20451641	Latch Pin	2
				39	80079817	Adapter, FSOR/ORB, 1.0 x 1.0	1

Figure 12-10: Hydraulic Power Package

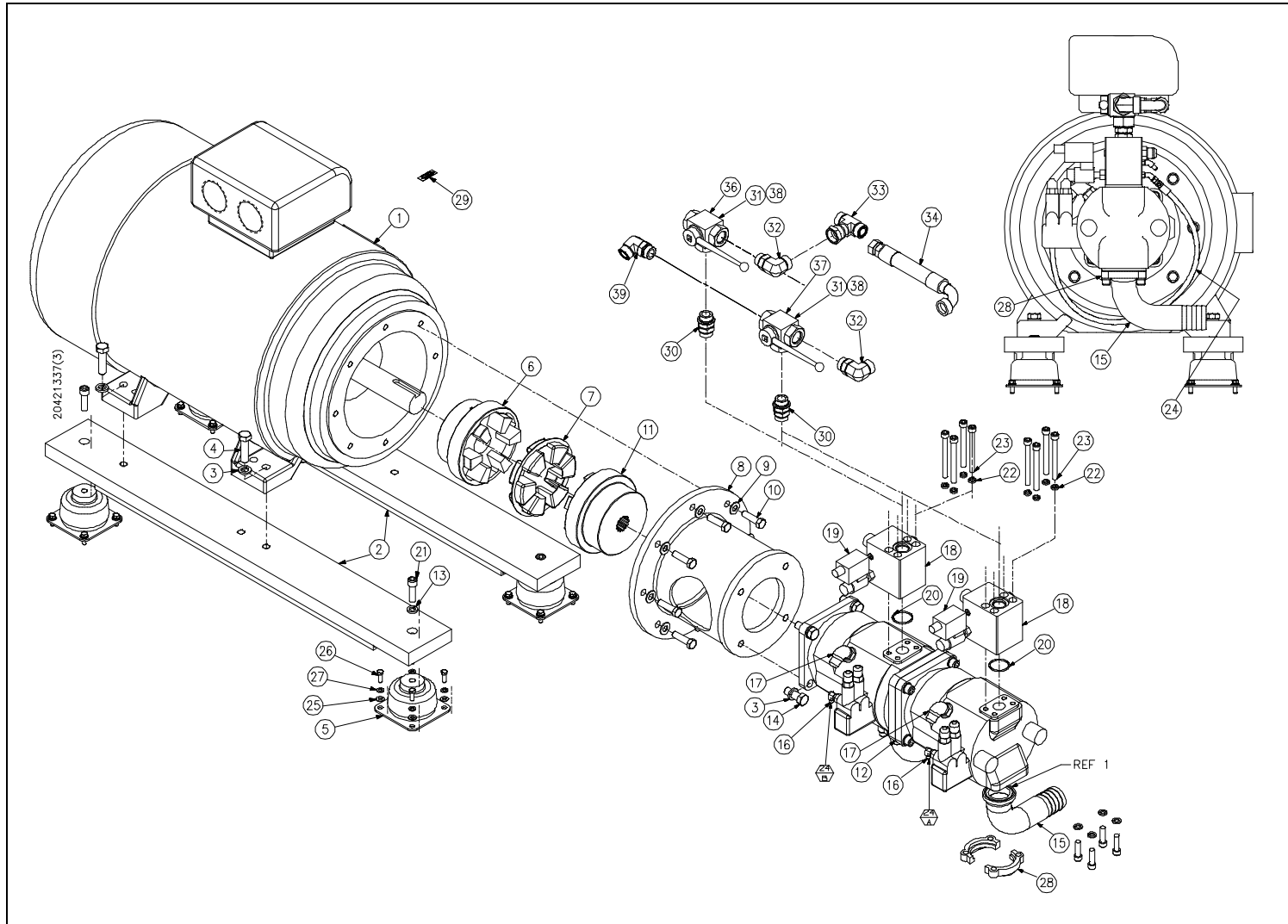



Table 12-11
Hydraulic Manifold Assembly
20423095

Item	Part Number	Description	Quantity
1	20423087	Manifold	1
2	80081733	Relief Valve, 205 Bar	1
3	20423219	Adapter, JIC/ORB, .75 x .50	1
4	10144749	Adapter, JIC/ORB, .25 x .25	2
5	05055017	Plug, ORB, .13	2
6	10187417	O-Ring, 1.50 x 1.69 x .09	1
7	05103189	Check Valve	1
Ref 1	80071087	Proportional Pressure Valve	--

Figure 12-11: Hydraulic Manifold Assembly

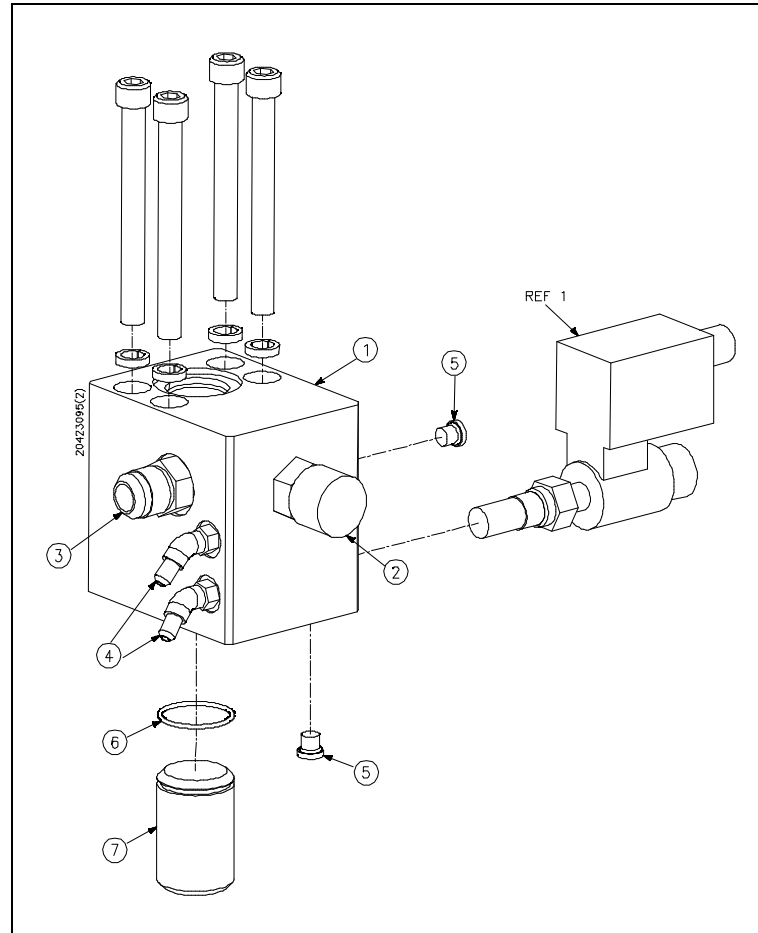



Table 12-12
Motor/Pump Assembly, 5 HP
20443394

Item	Part Number	Description	Quantity	Item	Part Number	Description	Quantity
1	20440477	Electric Motor, 5 HP	1	14	95716882	Hex Head Screw, 1/2-13 x 1-1/4	4
2	20422342	Flange, Motor/Pump	1	15	10091510	Decal, Arrow	1
3	20432339	Recirculation Pump	1	16	95070132	Hex Head Screw, 5/8-11 x 1-1/2	2
4	20427137	Flange, 4 Bolt, 1.25	1	17	05048780	Split Flange Kit, 2.0	1
5	20412413	Pressure Switch, 15 psi	1	18	10074961	O-Ring, 2.25 x 2.50 x .13	2
6	10119337	Split Flange, 1.25	1	19	20441089	Motor Mounting Plate	1
7	20433033	Flexible Drive Coupling	1	20	95065926	Socket Head Screw, 1/2-13 x 2.0	2
8	10074953	O-Ring, 1.50 x 1.75 x .13	2	21	20439840	Stud, .38 x 2.50	4
9	20438288	Hex Head Screw, 7/16-14 x 2.25	4	22	95423646	Hex Nut, 3/8-16	4
10	49899479	Lock Washer, .438	4	23	95830766	Lock Washer, .31	4
11	20444063	Adapter, Flange/Hose, 2.0 x 2.0	1	24	10192813	Plug, ORB, .25	1
12	95688719	Lock Washer, .63	2				
13	10170686	Lock Washer, .50	4				

Figure 12-12: Motor/Pump Assembly, 5 HP

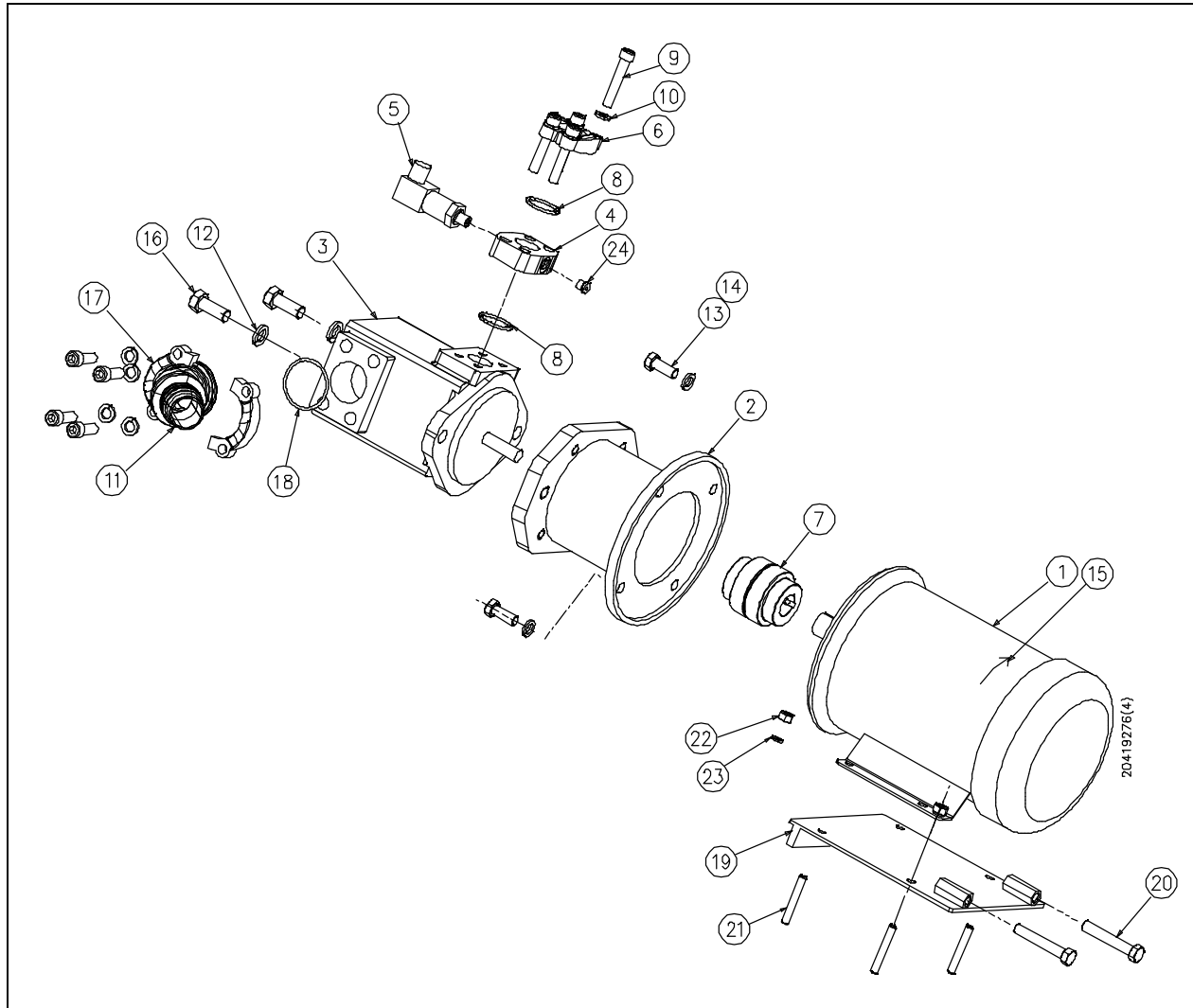



Table 12-13
Motor/Pump Assembly, 1.5 HP
20443376

Item	Part Number	Description	Quantity
1	20440469	Electric Motor, 1-1/2 HP	1
2	20418516	Flange, Motor/Pump	1
3	20438247	Flexible Drive Coupling	1
4	95838314	Lock Washer, .25	3
5	95572897	Hex Head Screw, 1/4-20 x 5/8	3
6	20455410	Booster Pump	1
7	20423647	Adapter, JIC/Pipe, .75 x .50	2
8	95416350	Hex Head Screw, 3/8-16 x 1-1/4	4
9	10069714	Flat Washer, .38	4
10	20423696	Adapter, Hose/JIC, .75 x .75	2
11	10091510	Arrow Decal	1

Figure 12-13: Motor/Pump Assembly, 1.5 HP

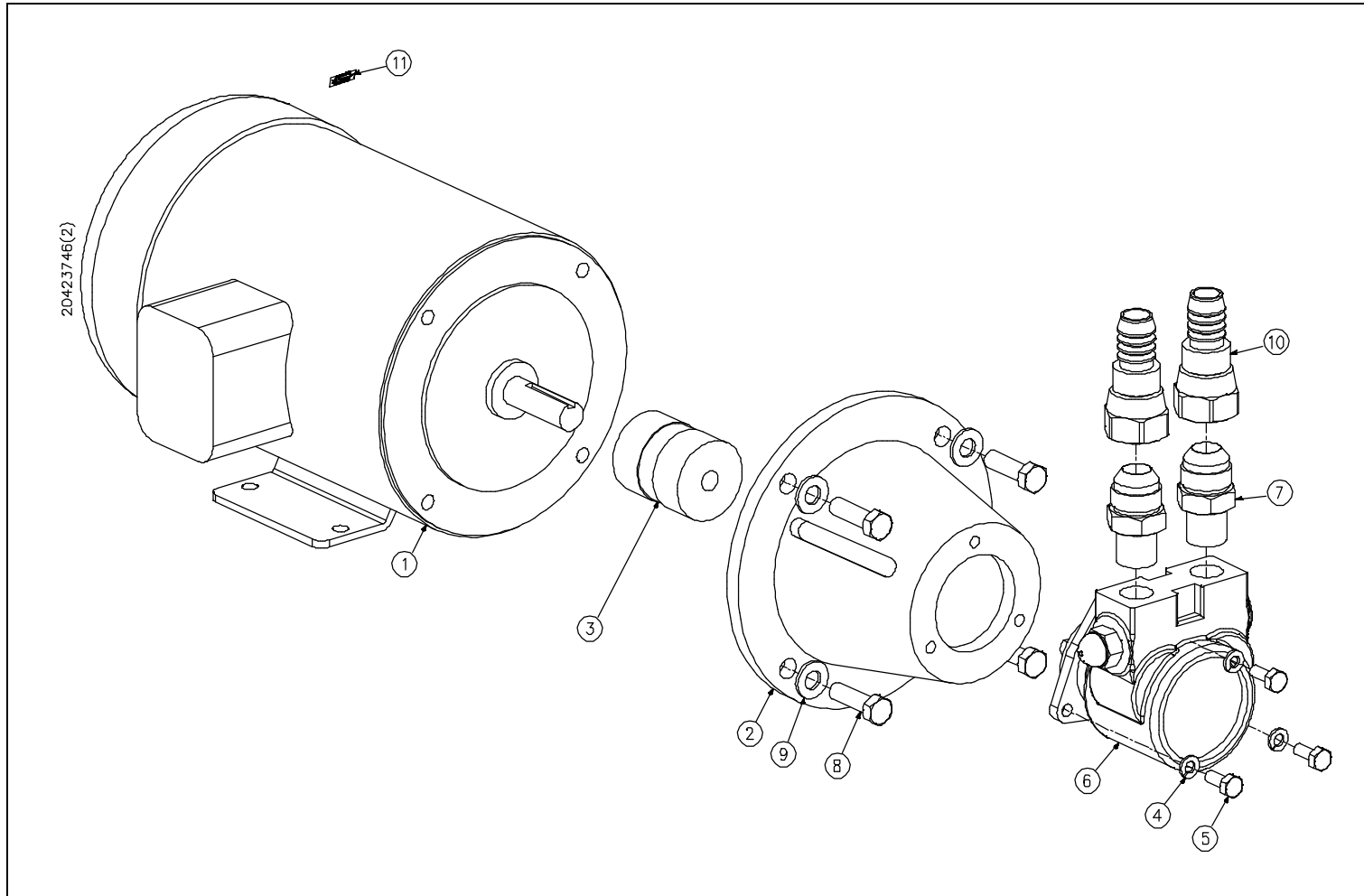



Table 12-14
Hydraulic Hose Connections
20426988

Item	Part Number	Description	Quantity
1	49891633	Hydraulic Hose, Suction/Return, 2.0	33.0"
2	20428507	Hydraulic Hose Assembly, .75 x 38.0	1
3	10079754	Radiator Hose, 2.50	30.0"
4	10117083	Hydraulic Hose Assembly, .75 x 45.0	1
5	10083517	Hose Clamp	4
6	20426767	Hydraulic Hose Assembly, 1.25 x 33.0	1
7	20434033	Hydraulic Hose Assembly, 1.25 x 24.0	1
8	10190767	Hydraulic Hose Assembly, .25 x 23.0	3
9	80079817	Adapter, FSOR/ORB, 1.0 x 1.0	1
10	20426733	Hydraulic Hose Assembly, .75 x 21.0	2
11	10119337	Split Flange, 1.25	2
12	10118065	Split Flange Kit, 1.0	2
13	20426791	Hydraulic Hose Assembly, 1.25 x 50.0	1
14	20434041	Hydraulic Hose Assembly, 1.25 x 40.0	1
15	20426824	Hydraulic Hose Assembly, 1.0 x 36.0	2
16	20427416	Adapter, FSOR/ORB, 1.0 x 1.0	1
17	20434049	Hydraulic Hose Assembly, .25 x 35.0	1
18	10194207	Hose Clamp, 2.31-3.25	8

Figure 12-14A: Hydraulic Hose Connections

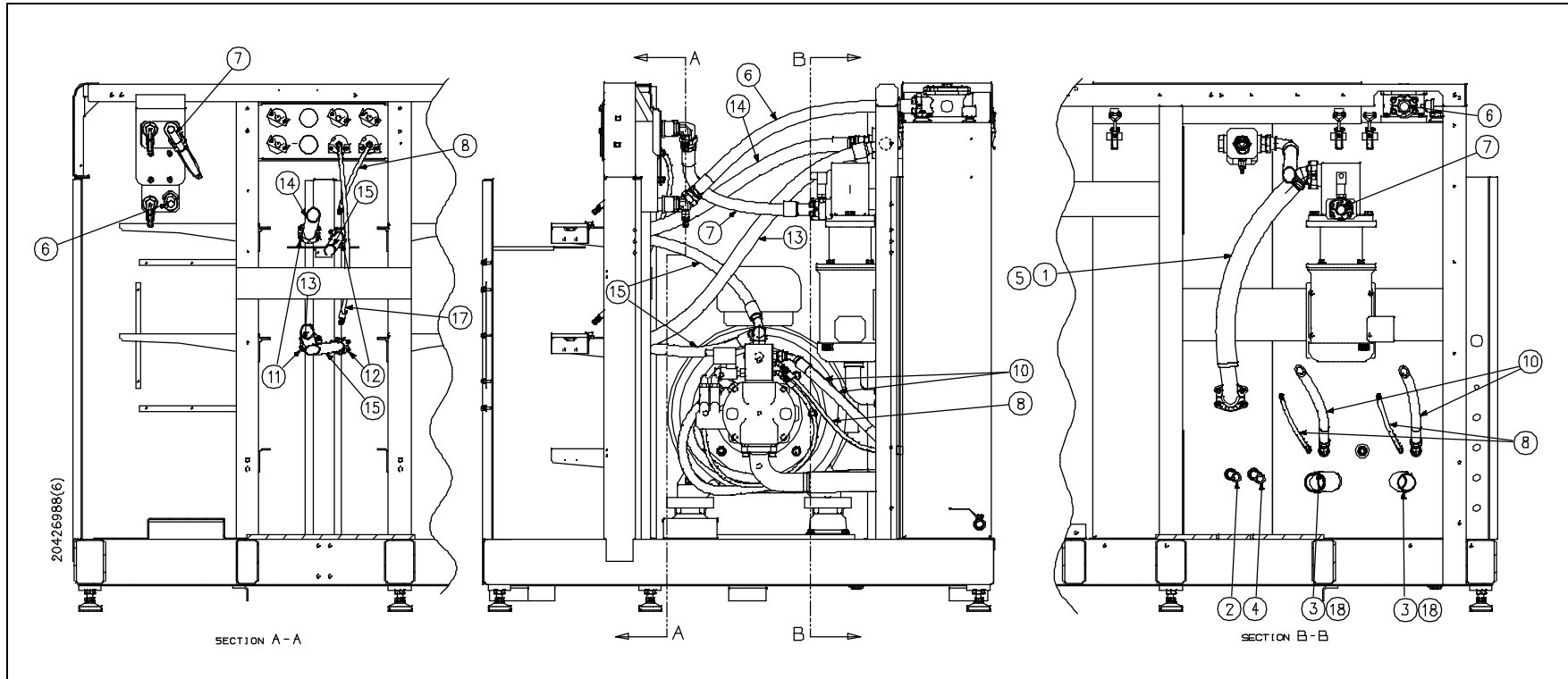

Figure 12-14B: Hydraulic Hose Connections

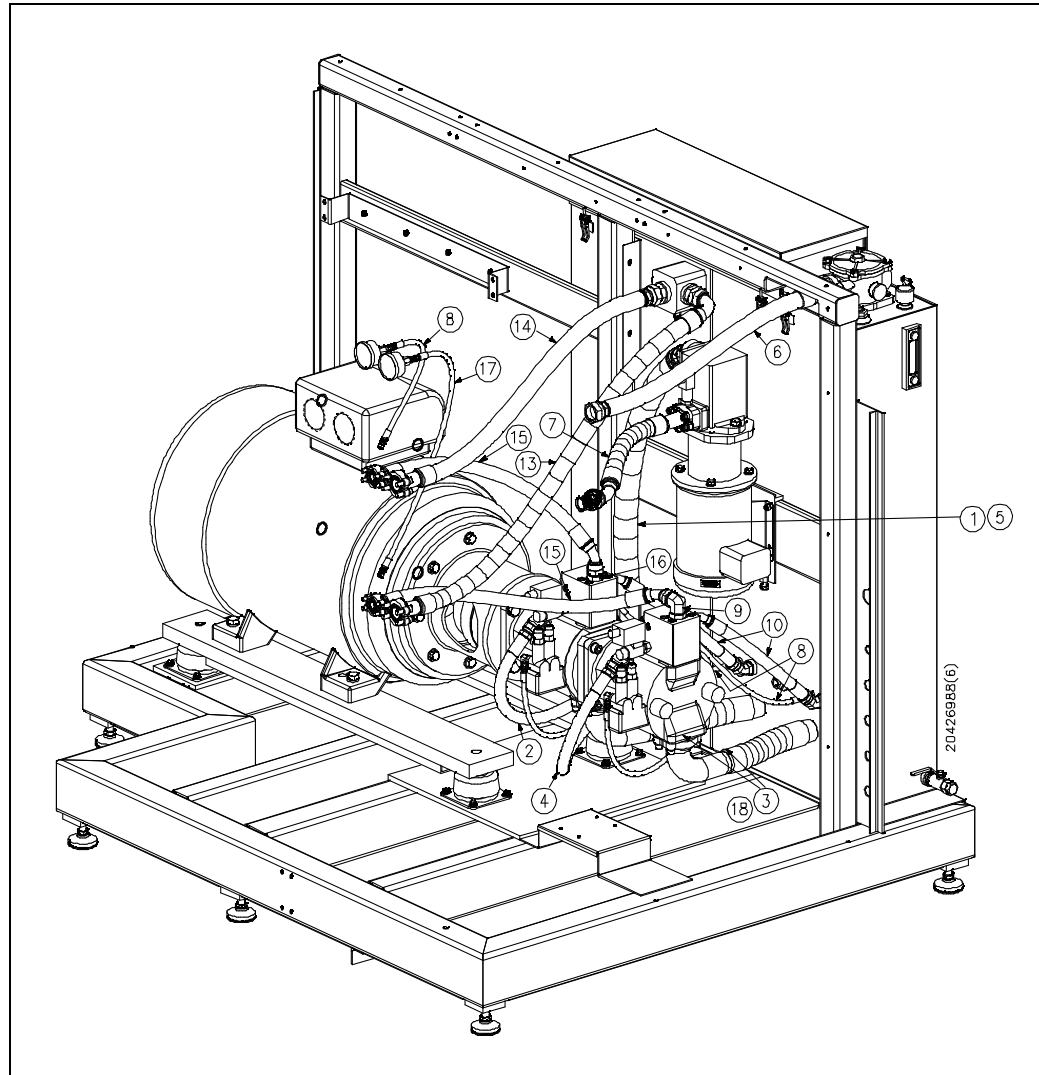



Table 12-15
Reservoir Assembly
20419549

Item	Part Number	Description	Quantity	Item	Part Number	Description	Quantity
2	49881774	Adapter, JIC/ORB, .75 x .75	2	13	49876089	Adapter, JIC/ORB, .25 x .25	2
3	20424397	Gasket	1	14	95702619	Adapter, JIC/ORB, .75 x .75	2
4	20433174	Filter Housing Assembly, Hydraulic	1	15	10091163	Adapter, JIC/ORB, .75 x .75	1
	20429609	Pressure Gauge, 0-60 psi		16	20431951	Adapter, Bleed/ORB, .25 x .25	1
5	20425181	Filter Element, Hydraulic	1	17	95750394	Lock Washer, .38	4
7	20421478	Plug, ORB, .75	2	18	10117026	Hex Head Screw, 3/8-16 x 1-1/4	4
8	10091858	Bulb Well	1	19	10119667	Split Flange, 1.50	1
9	20423902	Temperature/Level Switch	1		49882087	O-Ring, 1.88 x 2.13 x .13	
10	05092739	Air Breather	1	20	05048780	Split Flange Kit, 2.0	1
11	20451474	Level/Temperature Gauge	1		10074961	O-Ring, 2.25 x 2.50 x .13	
12	20425999	Ball Valve, 2 Way	1	21	05048806	Adapter, Hose/Flange, 2.0 x 2.0	1
				22	20422954	Adapter, JIC/ORB, 1.25 x 1.25	2
				23	10177582	Plug, ORB, 1.25, Non Redundant only	1
				24	10082501	Diffuser, Return Line	1

Figure 12-15: Reservoir Assembly

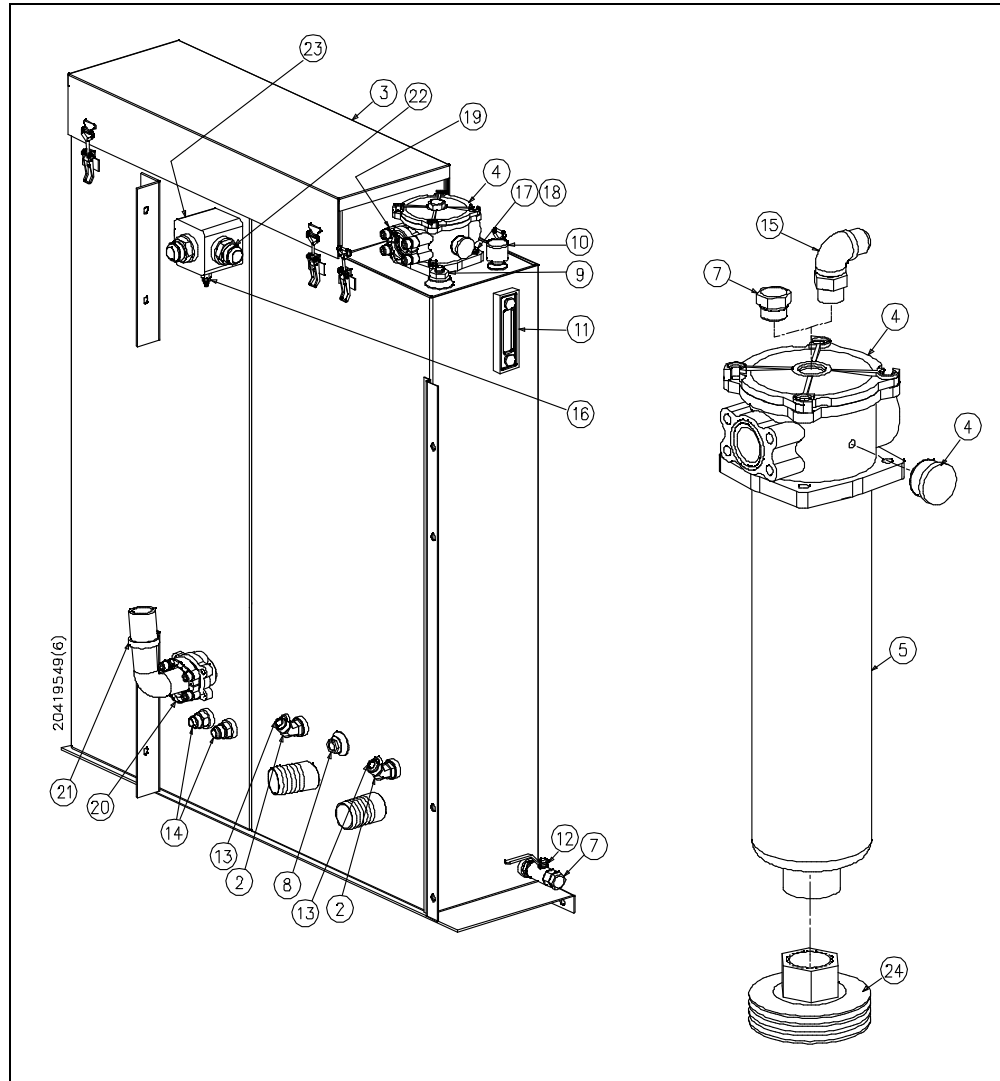



Table 12-16
Bulkhead Pipe Assembly
20424900

Item	Part Number	Description	Quantity	Item	Part Number	Description	Quantity
1	49886922	Adapter, Bulkhead, .50 x .50	3	18	05140751	Pressure Switch, 30 psi	1
2	10070092	Jam Nut, 1-14	3	19	49830714	Adapter, Hose/Pipe, .25 x .25	1
3	10073823	Tee, .50 x .50	1	20	10171783	Coupling, Pipe, .75 x .75	4
4	49834328	Adapter, Pipe/Tube, .50 x .25	1	21	10149979	Solenoid Valve	1
5	95157418	Adapter, JIC/Pipe, .50 x .50	1	22	20422311	Strainer	1
6	95680922	Adapter, JIC/Pipe, .50 x .50	2	23	20423399	Check Valve	1
7	10173805	Hose Barb, .50 x .50	3	24	20427796	Tee, Pipe, .75	1
8	10084523	Nipple, Pipe, .50 x 4.0	1	25	20418797	Adapter, Hose/Pipe, .75 x .75	1
9	20444318	Adapter, Pipe/Tube, .50 x .75	1	26	20427705	Adapter, Pipe/JIC, .75 x .50	1
10	20444336	Adapter, Tube/Pipe, .75 x .50	1	27	20423689	Hose, Push On, .75	120.0"
11	10091866	Water Modulating Valve	1	28	20424926	Filter Assembly, LP Water	1
12	10077055	Coupling, Bulkhead, .25 x .25	1	29	20453730	Check Valve	1
13	10078095	Coupling, Tube, .25 x .13	1	30	05111406	Adapter, JIC/Pipe, .50 x .25	4
14	10079903	Poly Tube, .25	47.0"	31	10189025	Adapter, Hose/JIC, .50 x .50	5
15	20425676	Adapter, JIC/Pipe, .75 x .75	1	32	20421272	Hose, Push On, .50	525.0"
16	20425330	Barb, Hose/JIC	1	33	10084226	Hydraulic Hose, .25	250.0"
17	20433538	Water Manifold	1	34	10078335	Coupling, Pipe, .25 x .13	1



Table 12-16
Bulkhead Pipe Assembly
20424900

Item	Part Number	Description	Quantity	Item	Part Number	Description	Quantity
35	49888035	Solenoid Valve	1	40	49831480	Grommet, 3.0 x 2.25	1
36	95670972	Lock Washer, .38	6	42	49836513	Flat Washer, 1.0	2
37	95215075	Hex Head Screw, 3/8-16 x 1.0	6	43	20465116	Washer, Bulkhead	2
38	10078137	Elbow, Pipe, .38 x .38	4				
39	10174407	Hose Barb, .50 x .38	4				

Figure 12-16: Bulkhead Pipe Assembly

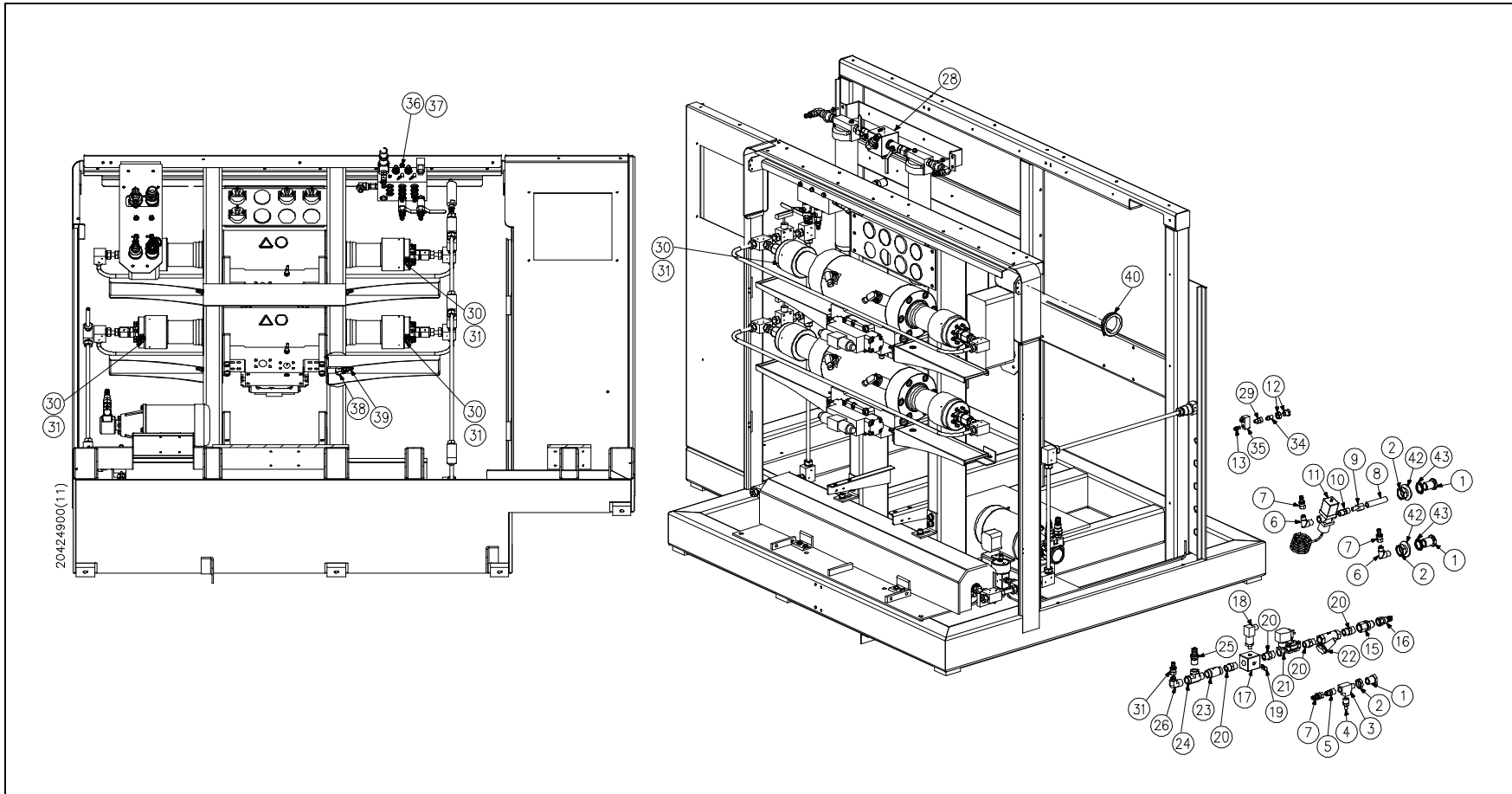



Table 12-17
Low Pressure Water Filter Assembly
20424926

Item	Part Number	Description	Quantity	Item	Part Number	Description	Quantity
1	05038690	Filter Housing Assembly	2	10	10069748	Flat Washer, .25	4
2	49838386	Pipe Nipple, .75 x 4.0	2	11	49868813	Temperature Sensor, 128 F	1
3	49833924	Manifold, Left	2	12	49830714	Adapter, Hose/Pipe, .25 x .25	1
4	49834716	Filter Element, 10 Micron	2	13	20425330	Barb, Hose/JIC	1
5	49833882	Adapter, Hose/ORB, .50 x .50	2	14	20433497	U-Bolt, 1.0	4
6	20426024	Adapter, ORB/Pipe, .75 x .75	2	15	95838314	Lock Washer, .25	4
7	10171783	Coupling, Pipe, .75 x .75	2	16	20436214	Adapter, JIC/ORB, .75 x .75	1
9	20433520	Manifold, Pre-Filter	1	17	05135637	Plug, Pipe, .25	2
				18	95473997	Hex Nut, 1/4-20	4
				Ref 1	20433546	Bracket, Water Filter	--

Figure 12-17: Low Pressure Water Filter Assembly

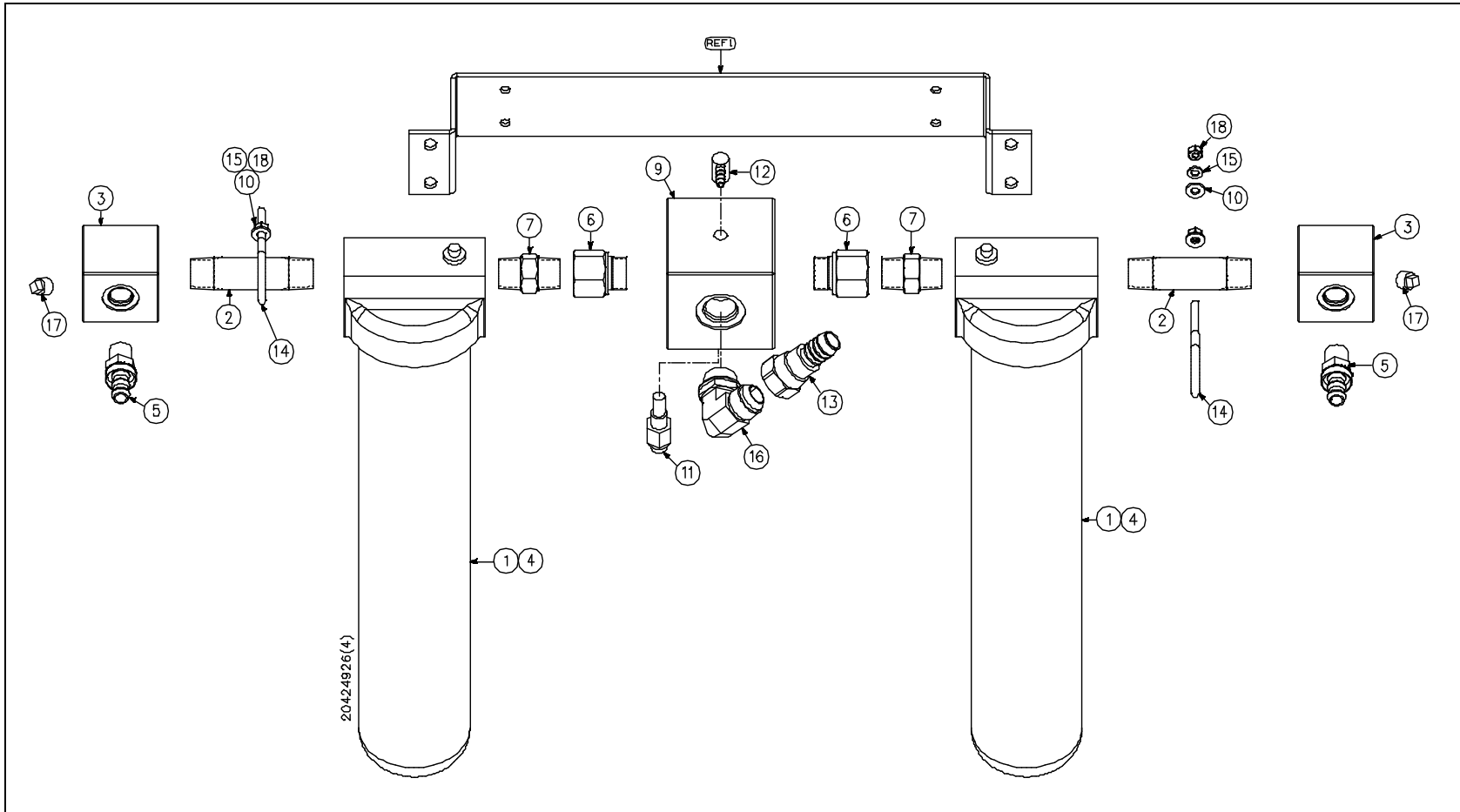



Table 12-18
Low Pressure Water Manifold
20443699/20433512

Item	Part Number	Description	Quantity	
			Redundant 20443699	Non Redundant 20433512
1	20433504	Manifold	1	1
2	20423326	2-Way Ball Valve	3	2
3	49830714	Adapter, Hose/Pipe, .25 x .25	3	2
4	49833882	Adapter, Hose/ORB, .50 x .50	14	10
5	05142062	Pressure Switch, 60 psi	1	1
6	05070982	Relief Valve, 50-150 psi	1	1
7	10187722	Elbow, Pipe, .50 x .50	1	1
8	10171825	Hose Barb, .50 x .50	1	1
9	20451755	Plug, ORB, .50		4
10	20424884	Adapter, ORB/Pipe, .50 x .50	1	1
11	20423738	Relief Valve, 60-175 psi	1	1
12	49895303	Adapter, JIC/Pipe, .50 x .50	1	1
13	10189025	Adapter, Hose/JIC, .50 x .50	1	1
14	05135637	Plug, Pipe, .25		1

Figure 12-18: Low Pressure Water Manifold

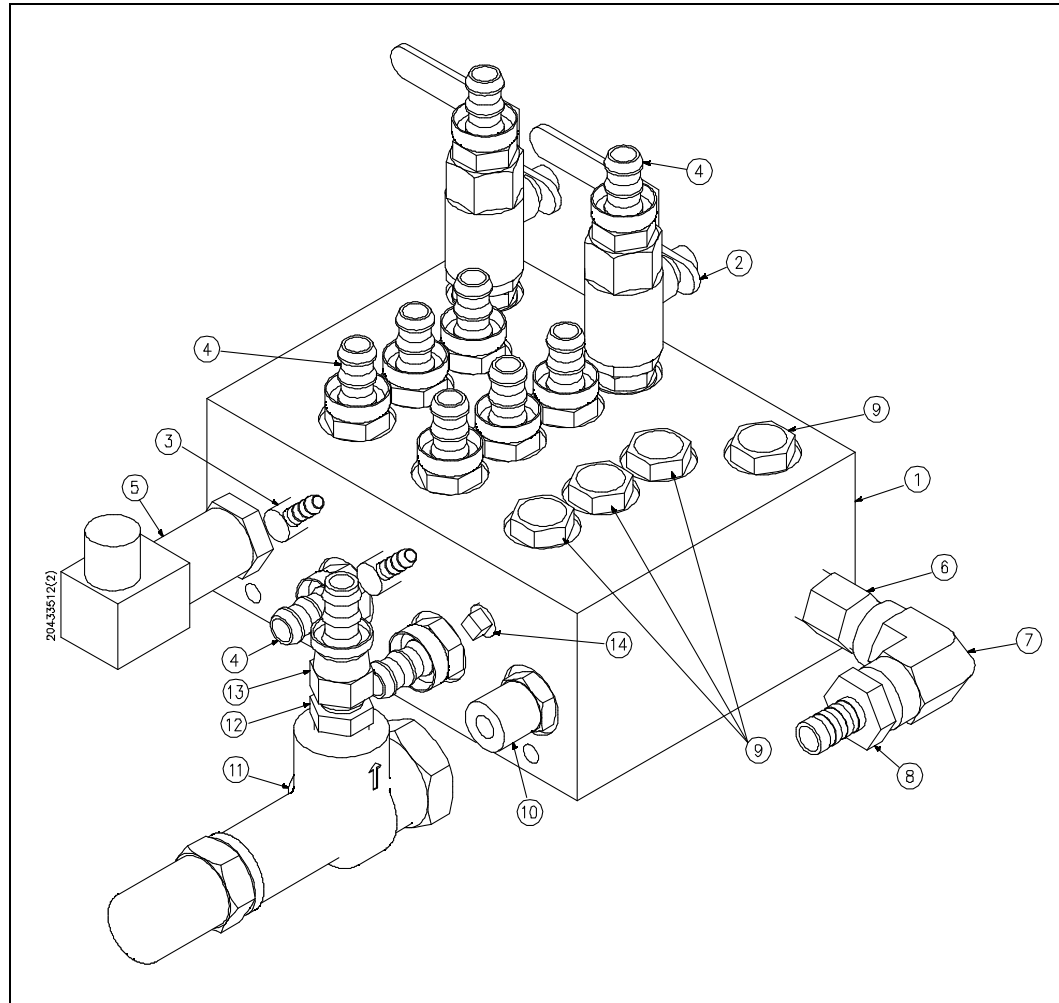



Table 12-19
Gauge Assembly
20441302/20443707

Item	Part Number	Description	Quantity	
			Redundant 20441302	Non Redundant 20443707
1	20433702	Decal, Gauge Label	1	1
2	05142294	Pressure Gauge, 0-5000	3	2
3	20434619	Pressure Gauge, 0-200	5	4
4	20434025	Gauge Bracket	3	2
5	10133932	Adapter, JIC/Pipe, .25 x .25	3	2
6	49830722	Adapter, Hose/Pipe, .25 x .25	5	4
7	05068887	Hole Seal		2
Ref 1	20427045	Support, Gauge Bracket	--	--

Figure 12-19: Gauge Assembly

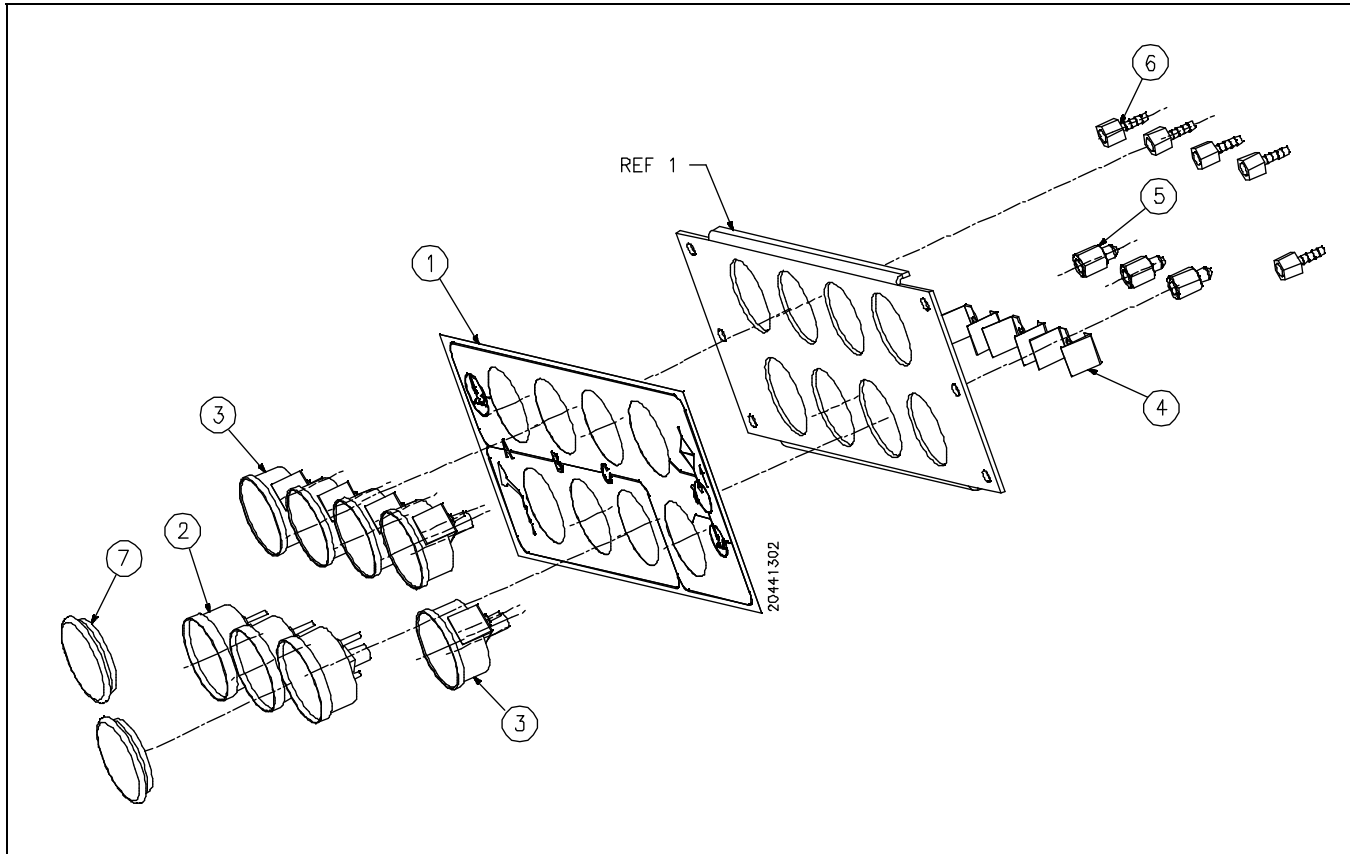



Table 12-20
Cover Assembly
20424027

Item	Part Number	Description	Quantity
1	20425735	Hinge	1
2	20425743	Top Cover	1
3	49834690	End Cover, Right	1
4	49834708	End Cover, Left	1
5	05091954	Button Head Screw, 3/8-16 x 1.0	18
6	05043237	Hex Nut, 3/8-16	18
7	49837511	Mounting Bracket, Gas Spring	2
8	95897948	Button Head Screw, 10-24 x 1/2	10
9	49832181	Nut, Flange	10
10	80076748	Cable, Lanyard	2
11	49837826	Handle	2
12	49837503	Gas Spring	2
13	20424061	Mounting Bracket, Gas Spring	2
14	20451045	Gasket, Top Cover	1
15	10177426	Seal Washer, .38	8
16	20451542	Button Head Screw, 3/8-16 x 1.25	8
17	95670972	Lock Washer, .38	8

Figure 12-20: Cover Assembly

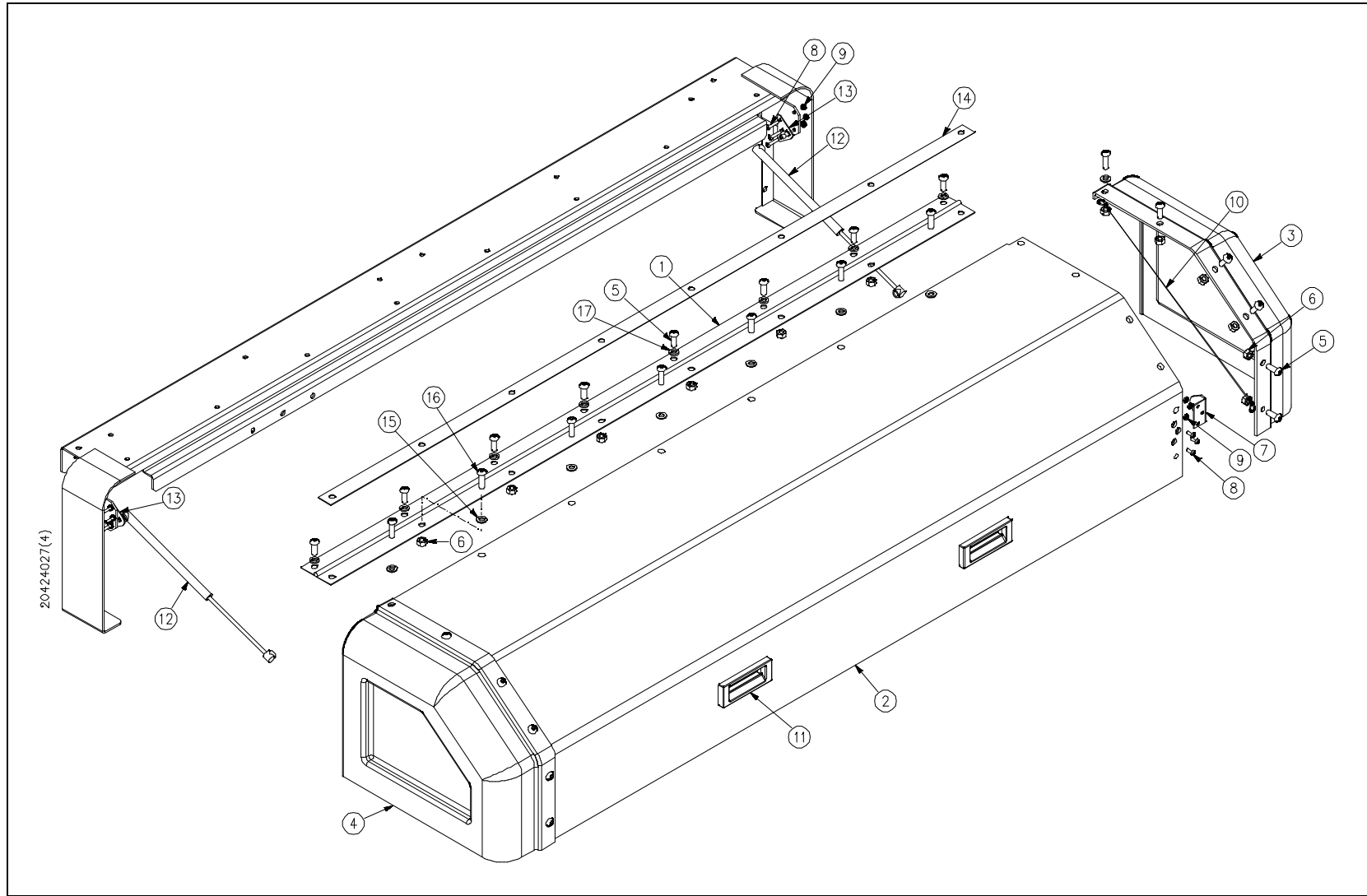



Table 12-21
Electrical Assembly
20467862

Item	Part Number	Description	Quantity	Item	Part Number	Description	Quantity
1	20425858	Harness, Sensor/Solenoid Cable	1	17	20452887	Welding Cable	500.0"
2	20426246	Flexible Conduit, 2.50	31.0"	18	20452905	Wire, #4, Green/Yellow	84.0"
3	05107347	Lock Nut, 2.50	2	19	95750394	Lock Washer, .38	4
4	20427069	Connector, Flexible Conduit, 2.50	1	20	05140926	Wire, #16, Orange	544.0"
5	10098762	Flexible Conduit, .50	132.0"	21	20467768	Starter/Controller Configuration	1
6	10085538	Connector, Flexible Conduit, .50	4	22	80080344	Terminal Lug, #10-250	6
7	10083012	Lock Nut, .50	6	23	80079775	Cable, 10 Conductor	78.0"
8	20426254	Bushing, Conduit, 2.50 x 2.50	2	24	20430457	Electric Controller Assembly	1
9	05062112	Bushing, Conduit, .50 x .50	3	25	95416319	Hex Head Screw, 3/8-16 x 1	4
10	05056791	Ring Terminal, #10, .25	10	26	10069714	Flat Washer, .38	4
11	10094043	Wire, #12, Black	500.0"	27	20433447	Clamp, Tie	15
12	10094035	Wire, #12, Green	160.0"	28	10139475	Flat Head Screw, 1/4-20 x 1-1/4	4
13	49874191	Hole Seal, .50	5	29	20435189	Enclosure Window Kit	1
14	05097464	Ring Terminal, #4	2	30	49838478	Pressure Transducer	1
15	10067205	Cable Connector, .50	3	31	10082857	Gasket Assembly	7
16	49867104	Cable, #18	200.0"	32	20495943	Bushing, Conduit, 1.0 x .50	1
				33	20426262	Conduit Connector	1

Figure 12-21: Electrical Assembly

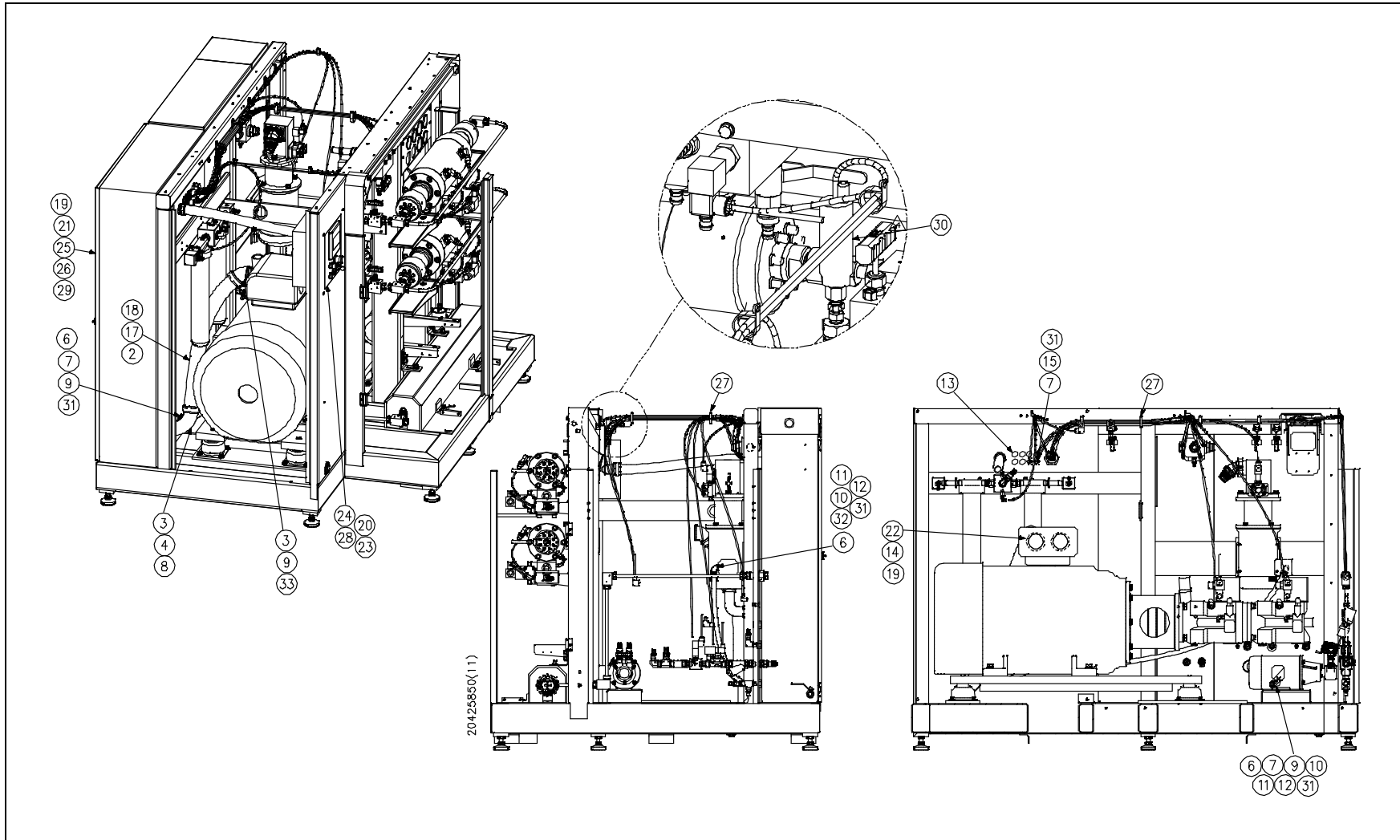



Table 12-22
Electrical Controller Assembly
20430457

Item	Part Number	Description	Quantity
1	20430415	Enclosure	1
2	10080661	Connector, Flexible Conduit, 1.50	1
3	10086700	Flexible Conduit, 1.50	29.0"
4	10085520	Connector, Flexible Conduit, 1.50	1
5	10113702	Lock Nut, 1.50	2
6	05081377	Bushing, Conduit, 1.50 x 1.50	2

Figure 12-22: Electrical Controller Assembly

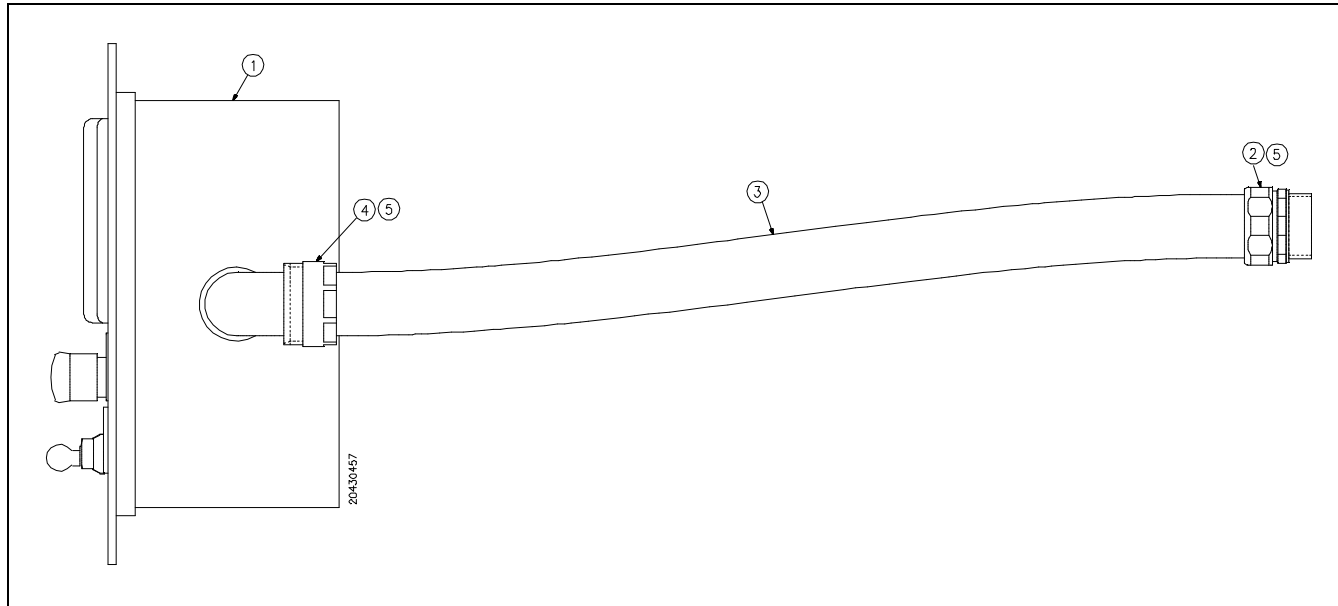



Table 12-23
Controls Subassembly
20424258

Item	Part Number	Description	Quantity	Item	Part Number	Description	Quantity
1	10176410	Wire, #16, Blue	3000.0"	21	49887813	Cable Connector, .50	4
2	10170165	Wire, #16, Green/Yellow	190.0"	22	05113634	Terminal Block	27
3	05032420	Terminal Block	10	23	05112826	Jumper, Terminal Block	1
4	10103034	DIN Rail	36.0"	24	20425866	Subplate	1
5	10157667	Pan Head Screw, 10-32 x 3/4	12	25	10157659	Lock Washer, .25	1
6	20436867	Plug, Disconnect	26	26	05021944	Wiring Duct, 1.0	3
7	10181873	Ring Terminal, #16-#14	1	27	10170132	Rivet, Nylon	70
8	49887417	Flat Head Screw, 8-32 x 1	1	28	49874191	Hole Seal, .50	6
9	95071247	Hex Nut, #10-32	1	29	05140926	Wire, #16, Orange	192.0"
10	05032438	Terminal Block	54	30	10185395	Connector, Crimp	200
11	05032362	End Anchor	4	31	20424553	Enclosure	1
12	05032370	End Barrier	4	32	10170157	Wire, #10, Green/Yellow	36.0"
13	05032388	Jumper, Terminal Block	1	33	10094712	Ring Terminal, 14-10	3
14	05032396	Terminal Block Marker	0.9	34	95416335	Hex Nut, 1/4-20	4
15	05032412	Terminal Block Marker	0.4	35	10102242	Spiral Wrap, .38	12.0"
17	10069789	Flat Washer, #10	1	36	05115134	End Barrier	1
18	95730758	Lock Washer, #10	1	37	05117601	End Barrier	2
19	80079742	Washer, Interlock Contact	1	38	05115704	Terminal Block	1

Figure 12-23: Controls Subassembly

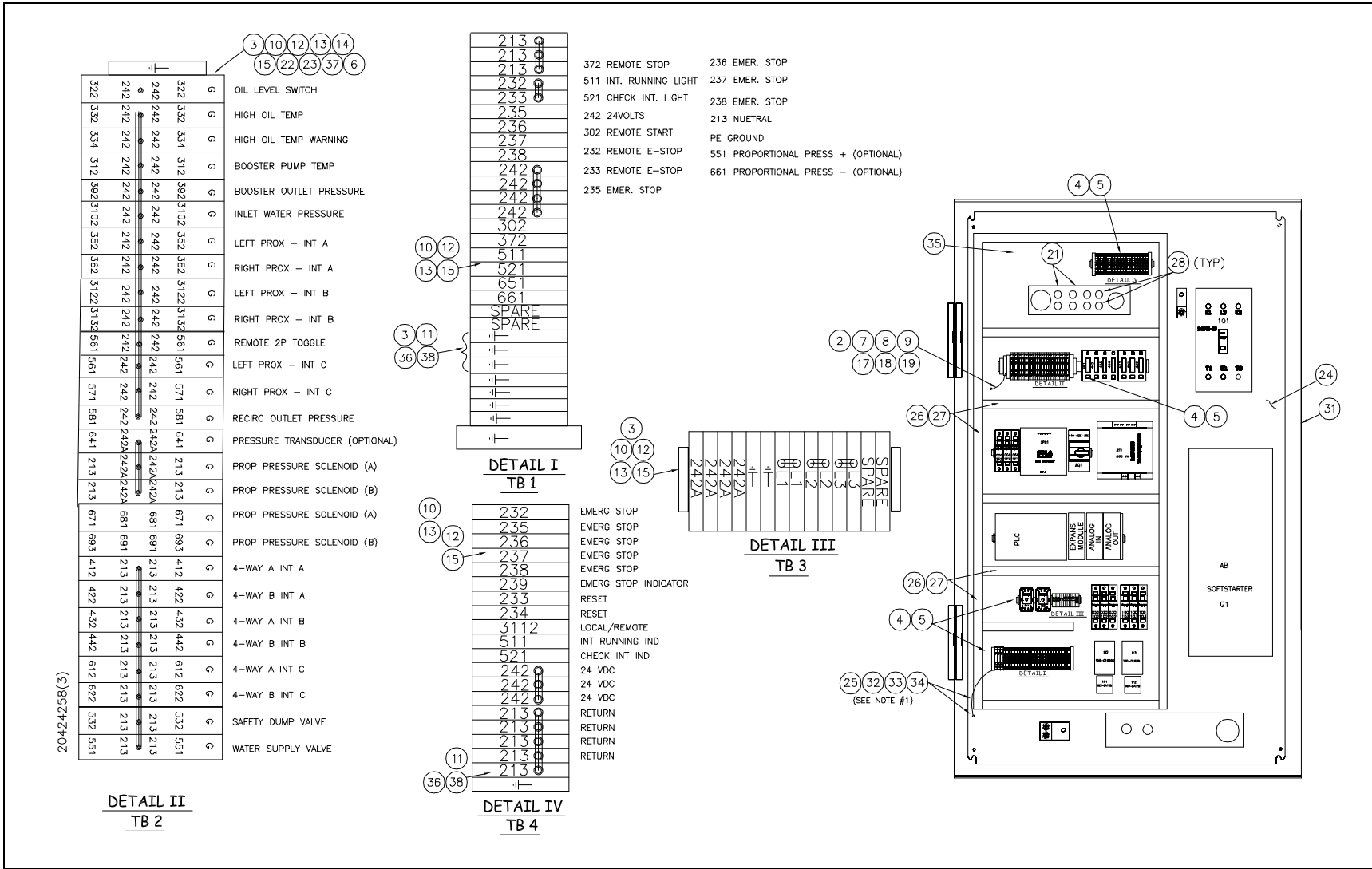



Table 12-24
Starter/Controller Configuration
20467768

Item	Part Number	Description	Quantity	Item	Part Number	Description	Quantity
1	20470699	Circuit Breaker, 225A, 600V	1	20	10170157	Wire, #10, Green/Yellow	42.0"
2	05081955	Socket Head Screw, 8-32 x 2	4	21	05019898	Wire, #14, Black	90.0"
3	80074131	Circuit Breaker, 2A, 480VAC	1	22	05019617	Connector, Crimp, #14/2.5MM	12
4	80080377	Rotary Drive, 250A	1	23	05140686	Circuit Breaker, 600V	1
5	80080385	Breaker, Terminal Cover	2	24	05032362	End Anchor	10
6	80073943	Terminal Lug, #6-#250	2	25	05115183	Power Supply, 24VDC, 10A	1
7	20451607	Welding Cable	108.0"	26	20424258	Controls Subassembly	1
8	05071048	Connector, Crimp Ferrule	6	27	05140686	Circuit Breaker, 600V	2
9	20433322	Contact, 16A, 24VDC	1	28	10185395	Connector, Crimp, #16	8
10	10157667	Pan Head Screw, 10-32 x 3/4	24	29	10176410	Wire, #16, Blue	48.0"
11	10103034	DIN Rail	100.0"	30	10170165	Wire, #16, Green/Yellow	48.0"
12	20433330	Relay, Overload	1	31	20424118	Terminal Lug, #6	3
13	20414961	Circuit Breaker, 10A	1	32	20472299	Terminal Cover	2
14	20465033	Terminal Lug	6	33	49830268	Cable, LRP Channel	1
17	95830766	Lock Washer, .31	3	34	10098226	Relay, Tube Base	1
18	95423620	Hex Head Screw, 5/16-18 x 3/4	3	35	10098242	Socket, Screw Terminal	1
19	20452905	Wire, #4, Green/Yellow	48.0"	36	10181550	Wire, #16, Red	100.0"
				37	10196012	Relay Base	1



Table 12-24
Starter/Controller Configuration
20467768

Item	Part Number	Description	Quantity	Item	Part Number	Description	Quantity
38	10186104	Relay, Tube Base	1	46	-----	Not used	--
39	05144316	Controller, Base	1	47	20496794	Protective Module	1
40	05144308	Controller, Program	1	48	20435751	Filter, Softstart	
41	49836562	Transformer, Controller	1	49	10156859	Rack, I/O	2
42	80072200	Analog Input Card	1	50	10146363	Output Module	7
43	80072218	Analog Output Card	1	51	20432357	Ground Lug, 14-2	1
44	05122379	End Cap, PLC	1	52	20421032	Relay, Overload, 1.6-5A	1
45	20423986	Expansion Module	1	53	20413385	Contact, 9A, 24VDC	1
				54	20436826	Circuit Breaker, 10A, 460V	1

Figure 12-24: Starter/Controller Configuration

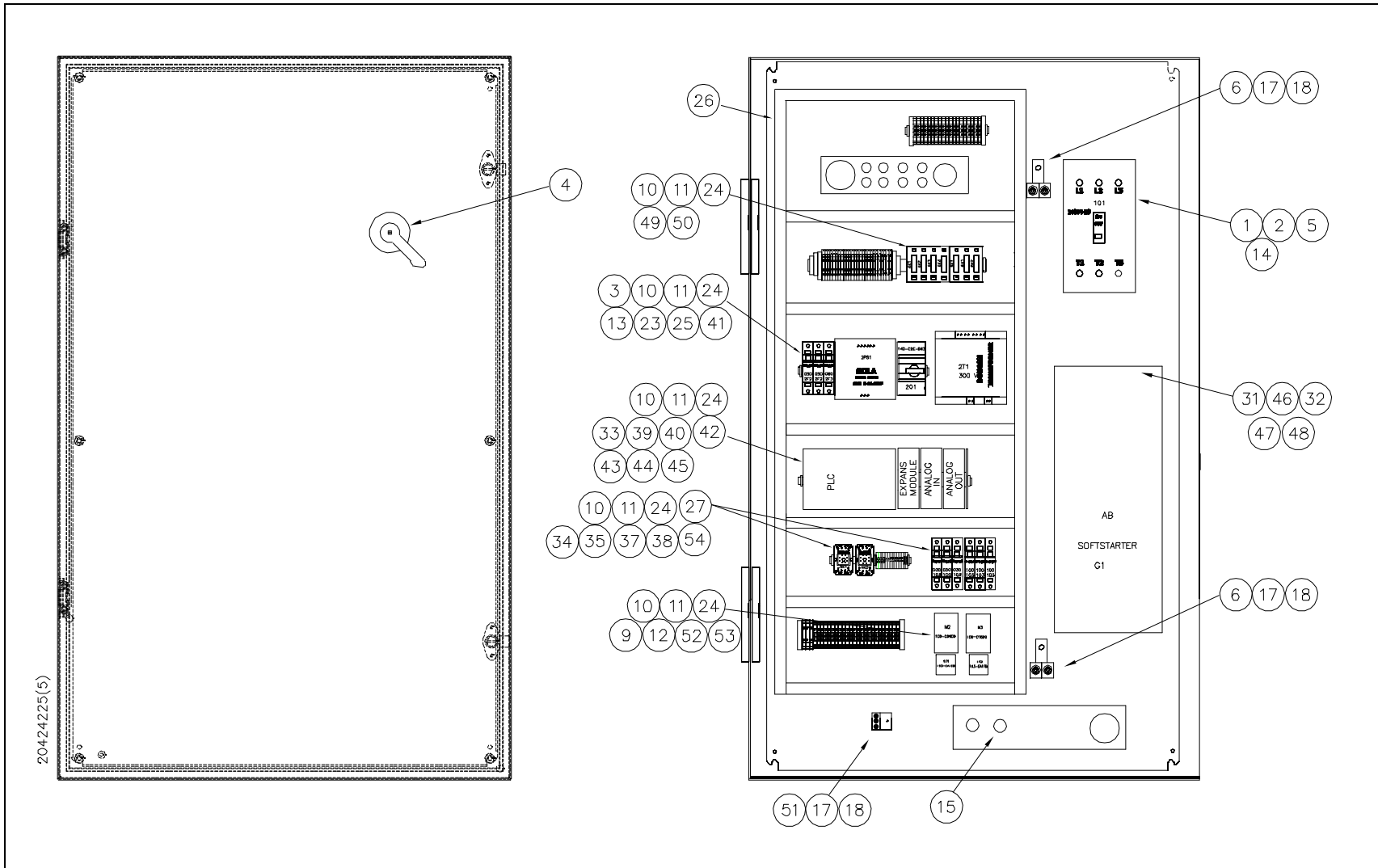



Table 12-25
Redundant Kit
20428267

Item	Part Number	Description	Quantity	Item	Part Number	Description	Quantity
1	20424142	Intensifier Topworks	1	19	20422954	Adapter, JIC/ORB, 1.25 x 1.25	1
2	10079119	HP Collar, .56	2	20	10119337	Split Flange, 1.25	1
3	10078608	HP Gland, .56	2	21	10118065	Split Flange Kit, 1.0	1
4	10069326	HP Tube, .56 x 4.0	4	22	20426798	Hydraulic Hose Assembly, 1.25 x 64.0	1
5	10078525	Elbow, HP, .56 x .56	1	23	20431331	Hydraulic Hose Assembly, 1.0 x 43.0	1
6	05131347	Ferrule, .50	6	24	10189025	Adapter, Hose/JIC, .50 x .50	2
7	20429255	HP Tube, Bent, .56	1	25	05111406	Adapter, JIC/Pipe, .50 x .25	2
8	10079465	Tee, HP, .56	2	26	10084226	Hydraulic Hose, .25	35.0"
9	10078889	2-Way Valve	1	27	20421272	Hose, Push On, .50	150.0"
10	05086905	Flexible Conduit	95.0"	28	95688750	Lock Washer, .50	6
11	20420858	Manifold Assembly, Hydraulic	1	29	95413696	Lock Washer, .50	4
12	49888746	HP Tube, .56 x 13.58	1	30	95229852	Socket Head Screw, 1/2-13 x 1-1/4	4
13	10166692	HP Tube, .56 x 12.63	1	31	10067205	Cable Connector, .50	4
14	05041058	Socket Head Screw, 3/8-16 x 2-1/4	8	32	05050588	Valve Connector	2
15	95688743	Lock Washer, .38	8	33	20434421	Connector, Plug, 4M	2
16	20437206	Directional Control Valve	1	34	10083012	Lock Nut, .50	4
17	95055059	Socket Head Screw, 1/2-13 x 2-1/2	6	35	20424217	Drip Pan	2
18	10118206	O-Ring, 1.31 x 1.56 x .13	2	36	95423653	Hex Head Screw, 1/4-20 x 1/2	4



Table 12-25
Redundant Kit
20428267

Item	Part Number	Description	Quantity	Item	Part Number	Description	Quantity
37	95648150	Lock Washer, .25	4	39	10078137	Elbow, Pipe, .38 x .38	2
38	20434413	Hydraulic Hose Assembly, .25 x 44.0	1	40	10174407	Hose Barb, .50 x .38	2

Figure 12-25: Redundant Kit

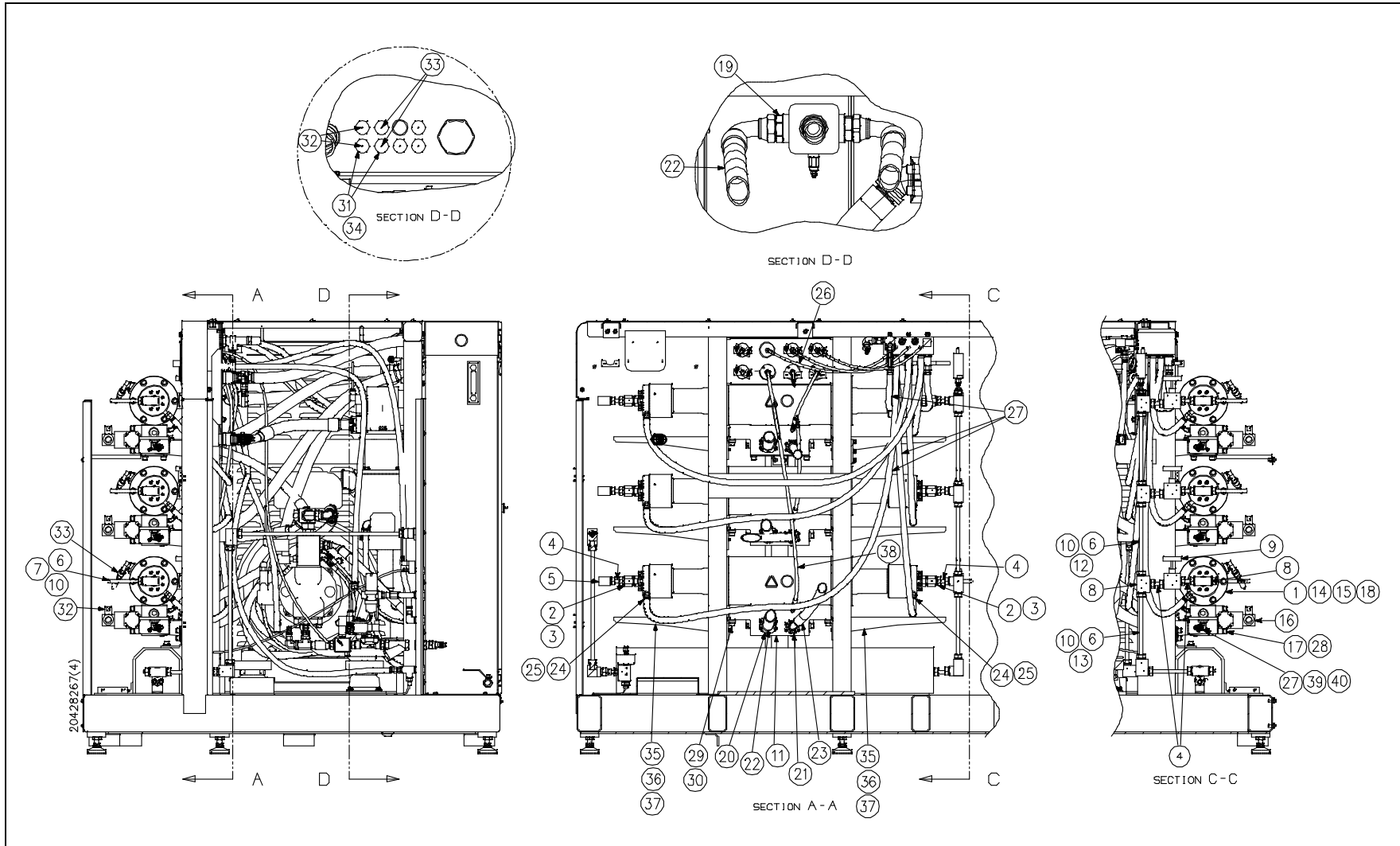

Table 12-26
High Pressure Coning Tools

Item	Part Number	Description
	05108832	Hand Coning Tool Assembly, .25
	05108857	Hand Coning Tool Assembly, .38
	05108840	Hand Coning Tool Assembly, .56
	05109897	Power Coning Tool Assembly, .25
	05109889	Power Coning Tool Assembly, .38
	05109871	Power Coning Tool Assembly, .56
1	05108808	Blade, .25
	05108824	Blade, .38
	05108816	Blade, .56
2	05108972	Collet, .25
	05108964	Collet, .38
	20439964	Collet, .56
3	05109814	Retainer, .25
	05109822	Retainer,.38
	05109830	Retainer, .56
	05120472	Cone and Thread Lubricant, 4 oz.

Figure 12-26A: Hand Coning Tool Assembly

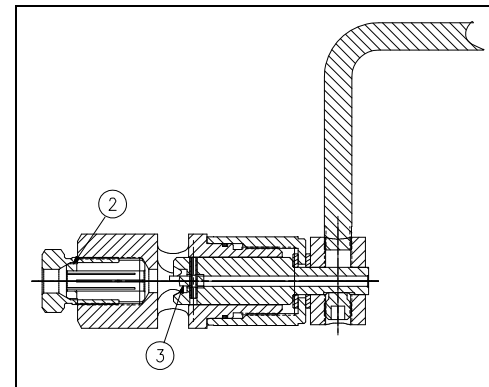

Figure 12-26B: Power Coning Tool Assembly

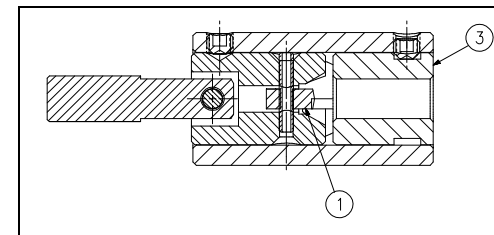

Table 12-27
High Pressure Threading Tools

Item	Part Number	Description
	05108865	Hand Threading Tool Assembly, .25
	05108873	Hand Threading Tool Assembly, .38
	05108881	Hand Threading Tool Assembly, .56
	05122742	Power Threading Tool Assembly, .25
	05120258	Power Threading Tool Assembly, .38
	05122759	Power Threading Tool Assembly .56
1	05108899	1/4-20 Threading Die
	05108915	3/8-16 Threading Die
	10078301	9/16-18 Threading Die
2	05108741	Retainer, .25
	05108758	Retainer, .38
	05108766	Retainer, .56
	05108782	Tube Vise, .25
	05108790	Tube Vise, .38
	05108774	Tube Vise, .56
	20437825	Tube Vise, .75
	20440071	Tube Vise, 1.0

Figure 12-27A: Hand Threading Tool Assembly

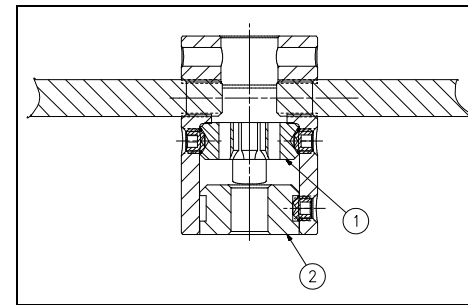

Figure 12-27B: Power Threading Tool Assembly

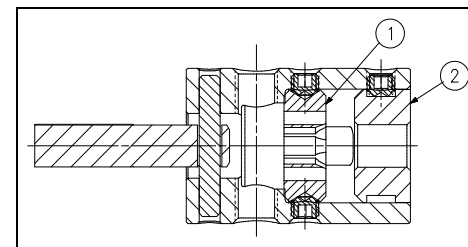

Table 12-28
Maintenance Tools and Lubricants

Item	Part Number	Description
1	20477460	Plunger Removal Tool, .88 Plunger
	20477469	Plunger Removal Tool, 1.13 Plunger
2	20484961	Vee Block Cradle
3	05066139	Cylinder Wrench
4	80079239	End Cap Wrench, HSEC, 6x/8x
5	80078330	HP Seal Removal Tool Stand
6	10079523	HP Plug, .38
	10078772	HP Plug, .56
7	10078129	HP Gland, .38
	10078608	HP Gland, .56
8	10148674	HP Seal Installation Tool, .88 Plunger
	05146618	HP Seal Installation Tool, 1.13 Plunger

Figure 12-28A: Maintenance Tools

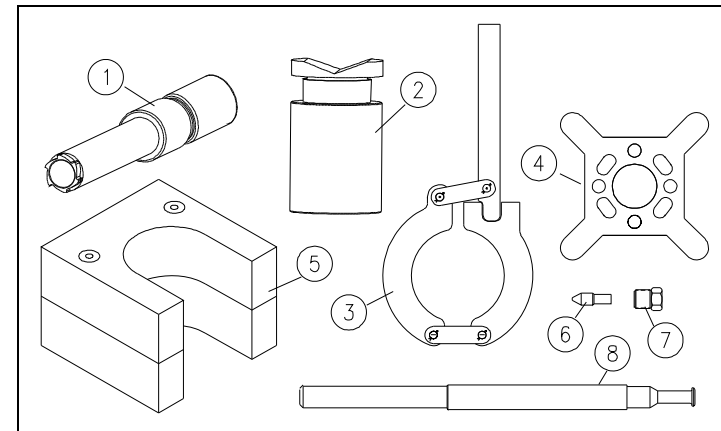

Table 12-28
Maintenance Tools and Lubricants

Item	Part Number	Description
	20470475	Seal Tool Kit, Pneumatic Control Valves
1	20470417	Seal Installation Tool
2	20470413	Seal Push Tool
3	05067350	Seal Positioning Tool
4	49833114	Seal Positioning Tool
		Lubricants
	10084440	Pure Goop Thread Lubricant, 1.0 oz.
	10087385	FML-2 Grease, 14.5 oz.
	49832199	JL-M Thread Lubricant, 16 oz.
	80082191	JL-M Thread Lubricant, 15 ML
	20487868	Threadlocker Adhesive
	20494983	Threadlocker Primer
	10184802	Optimol, Anti-Seize Grease

Figure 12-28B: Seal Tool Kit, Pneumatic Control Valves

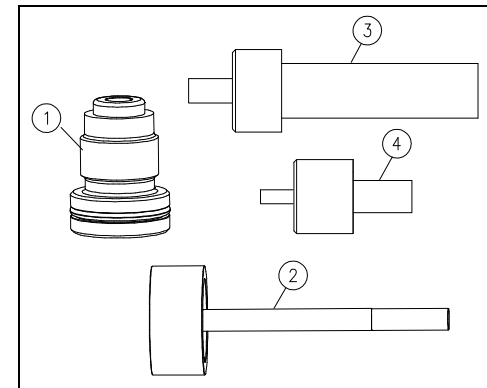

Table 12-29
Focusing Tubes

Part Number	Description	
05147889	R-100	0.018" (0.457 mm) x 2.00" (50.8 mm)
10139426	R-100	0.021" (0.533 mm) x 2.00" (50.8 mm)
20451227	R-100	0.021" (0.533 mm) x 3.13" (79.4 mm)
20452309	R-100	0.025" (0.635 mm) x 3.13" (79.4 mm)
10126969	R-100	0.030" (0.762 mm) x 3.13" (79.4 mm)
20428126	R-100	0.030" (0.762 mm) x 4.0" (101.6 mm)
20452161	R-100	0.030" (0.762 mm) x 6.0" (152.4 mm)
80075252	R-100	0.036" (0.914 mm) x 3.13" (79.4 mm)
49833593	R-100	0.039" (0.991 mm) x 3.13" (79.4 mm)
49835390	R-100	0.040" (1.016 mm) x 3.13" (79.4 mm)
20432695	R-100	0.043" (1.092 mm) x 2.0" (50.8 mm)
10126928	R-100	0.043" (1.092 mm) x 3.13" (79.4 mm)
20452135	R-100	0.043" (1.092 mm) x 4.0" (101.6 mm)
20452153	R-100	0.043" (1.092 mm) x 6.0" (152.4 mm)
10186799	R-100	0.050" (1.321 mm) x 3.13" (79.4 mm)
05117528	R-100	0.052" (1.321 mm) x 3.13" (79.4 mm)
05051891	R-100	0.058" (1.473 mm) x 3.13" (79.4 mm)
10126936	R-100	0.063" (1.600 mm) x 3.13" (79.4 mm)
10139418	R-100	0.093" (2.632 mm) x 3.13" (79.4 mm)

Figure 12-29A: R-100 Focusing Tube

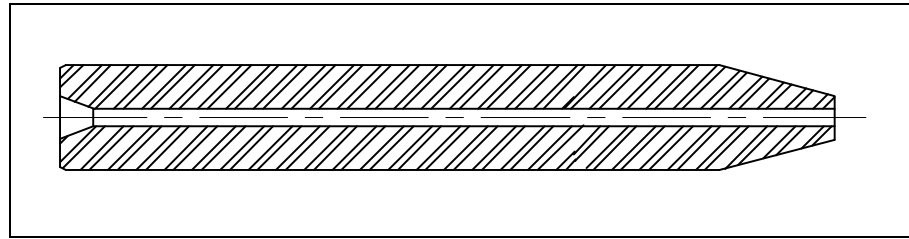

Table 12-29
Focusing Tubes

Part Number	Description	
05097928	R-500	0.021" (0.533 mm) x 2.00" (50.8 mm)
05105366	R-500	0.043" (1.092 mm) x 2.75" (69.9 mm)
05097944	R-500	0.030" (0.762 mm) x 3.13" (79.4 mm)
05116652	R-500	0.036" (0.914 mm) x 3.13" (79.4 mm)
05097936	R-500	0.043" (1.092 mm) x 3.13" (79.4 mm)
05130919	R-500	0.063" (1.600 mm) x 3.13" (79.4 mm)
05130927	R-500	0.093" (2.632 mm) x 3.13" (79.4 mm)

Figure 12-29B: R-500 Focusing Tube

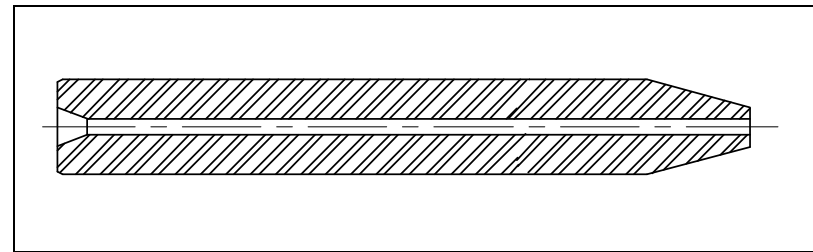

Table 12-30
Standard Sapphire Orifice

Part Number	Description	Part Number	Description	Part Number	Description
A2260001	0.001" (0.025 mm)	A2260009	0.009" (0.229 mm)	A2260018	0.018" (0.457 mm)
A2260002	0.002" (0.051 mm)	A2260010	0.010" (0.254 mm)	A2260019	0.019" (0.483 mm)
A2260003	0.003" (0.076 mm)	A2260011	0.011" (0.279 mm)	A2260020	0.020" (0.508 mm)
A2260004	0.004" (0.102 mm)	A2260012	0.012" (0.305 mm)	A2260021	0.021" (0.533 mm)
A2260005	0.005" (0.127 mm)	A2260013	0.013" (0.330 mm)	A2260022	0.022" (0.559 mm)
A2260006	0.006" (0.152 mm)	A2260014	0.014" (0.356 mm)	A2260024	0.024" (0.610 mm)
A2260007	0.007" (0.178 mm)	A2260015	0.015" (0.381 mm)	A2260028	0.028" (0.711 mm)
A2260008	0.008" (0.203 mm)	A2260016	0.016" (0.406 mm)	A2260032	0.032" (0.813 mm)

Figure 12-30: Standard Sapphire Orifice

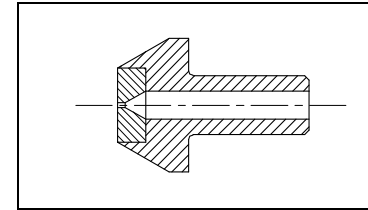

Table 12-31
Standard Diamond Orifice

Part Number	Description	Part Number	Description	Part Number	Description
49888852	0.003" (0.076 mm)	49888910	0.009" (0.229 mm)	49888969	0.016" (0.406 mm)
49888860	0.004" (0.102 mm)	49888928	0.010" (0.254 mm)	49888977	0.018" (0.457 mm)
49888878	0.005" (0.127 mm)	49888936	0.012" (0.305 mm)	20436198	0.019" (0.483 mm)
49888886	0.006" (0.152 mm)	49836786	0.013" (0.330 mm)	49888985	0.020" (0.508 mm)
49888894	0.007" (0.178 mm)	49888944	0.014" (0.356 mm)	49888993	0.022" (0.559 mm)
49888902	0.008" (0.203 mm)	49888951	0.015" (0.381 mm)		

Figure 12-31: Standard Diamond Orifice

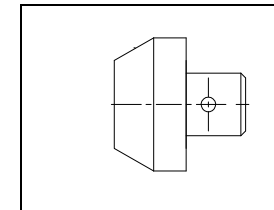

Table 12-32
High Pressure Fitting and Valve Assemblies

Part Number	Description		Part Number	Description	
10079028	Coupling, .25 x .25, F/F	<p>HP Coupling</p>	10079473	Bushing, .38 x .25, F/M	<p>HP Bushing</p>
10079614	Coupling, .38 x .25, F/F		10079432	Bushing, .38 x .25, M/F	
10078905	Coupling, .38 x .38, F/F		10079424	Bushing, .56 x .25, F/M	
10078145	Coupling, .56 x .25, F/F		10079580	Bushing, .56 x .25, M/F	
10079531	Coupling, .56 x .38, F/F		10079655	Bushing, .56 x .38, F/M	
10078640	Coupling, .56 x .56, F/F		10079457	Bushing, .56 x .38, M/F	
			49832801	Bushing, .75 x .56, F/M	
10078160	Bulkhead Coupling, .38 x .38, F/F	<p>HP Bulkhead Coupling</p>	10097228	Cross, .25	<p>HP Cross</p>
49830581	Bulkhead Coupling, .56 x .38, F/F		10078038	Cross, .38	
10079705	Bulkhead Coupling, .56 x .56, F/F		10079168	Cross, .56	
20424785	Bulkhead Coupling, .75 x .75, F/F		49832652	Cross, .75	
10079051	Elbow, .25 x .25, 90D	<p>HP Elbow</p>	10079481	Tee, .25	<p>HP Tee</p>
10078780	Elbow, .38 x .38, 90D		10078590	Tee, .38	
10078525	Elbow, .56 x .56, 90D		10079465	Tee, .56	
49832645	Elbow, .75 x .75, 90D		49832660	Tee, .75	

Table 12-32
High Pressure Fitting and Valve Assemblies

Part Number	Description		Part Number	Description	
10078426	Collar, .25	<i>HP Collar</i> 	10116333	Adapter Cone, .25	<i>HP Adapter Cone</i> 
10078715	Collar, .38		10078509	Adapter Cone, .38	
10079119	Collar, .56		10079291	Adapter Cone, .56	
49832686	Collar, .75		20448815	Adapter Cone, .75	
10078459	Gland, .25	<i>HP Gland</i> 	10078244	Plug, .25	<i>HP Plug</i> 
10078129	Gland, .38		10079523	Plug, .38	
10078608	Gland, .56		10078772	Plug, .56	
49832678	Gland, .75				
10078699	Anti-Vibration Gland, .25	<i>Anti-Vibration Gland</i> 			
10078913	Anti-Vibration Gland, .38				
10093573	Anti-Vibration Gland, .56				

Table 12-32
High Pressure Fitting and Valve Assemblies

Part Number	Description		Part Number	Description	
10079259	2 Way Straight, .25	<p><i>2 Way Straight Valve</i></p>	10079002	2 Way Angle, .25	<p><i>2 Way Angle Valve</i></p>
10078863	2 Way Straight, .35		10078749	2 Way Angle, .38	
10078889	2 Way Straight, .56		10079275	2 Way Angle, .56	
20432554	2 Way Straight, .75				
10097533	3 Way/1 Pressure Valve, .38	<p><i>3 Way Valve</i></p>	05137724	3 Way/2 Pressure Valve, .38	<p><i>3 Way Valve</i></p>
10097541	3 Way/1 Pressure Valve, .56		10153500	3 Way/2 Pressure Valve, .56	

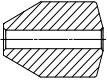
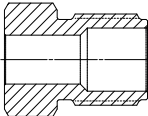
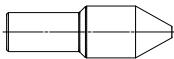
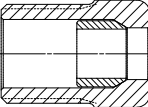

Table 12-33
Bulk High Pressure Tubing

Part Number	Description
10064376	.25 x .083, 20 ft (6.10 m)
10184810	.25 x .083, up to 40 ft (12.19 m)
10064665	.38 x .125, 20 ft (6.10 m)
10061190	.56 x .188, 20 ft (6.10 m)

High Pressure Tubing also available coned, threaded and/or autofrettaged

Figure 12-33: Bulk High Pressure Tubing Coned/Threaded Both Ends

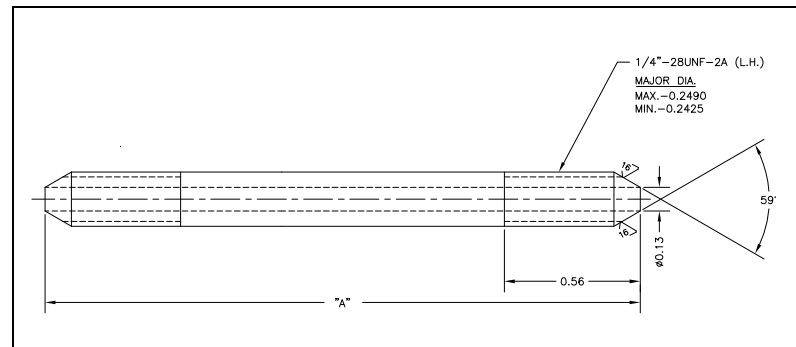

Table 12-34
High Pressure Water Filter Assemblies

Item	Part Number	Description	Quantity
	05114137	Inline Water Filter, .25	
1	05114129	Filter Body	1
2	05114152	Retainer, Filter Element	1
3	05110531	Filter Element	1
4	05114145	Adapter Gland	1
5	10078426	HP Collar	2
6	10078459	HP Gland	2
	CJ200988	Inline Water Filter, .38	
1	10078715	HP Collar	2
2	10078129	HP Gland	2
3	CJ300988	Filter Body	1
4	CJ400988	Adapter Gland	1
5	SKJA266	Filter Element	1
6	SKJA286	Retainer, Filter Element	1
7	SKJA287	Bayonet Nipple	1

Figure 12-34A: HP Inline Water Filter, .25

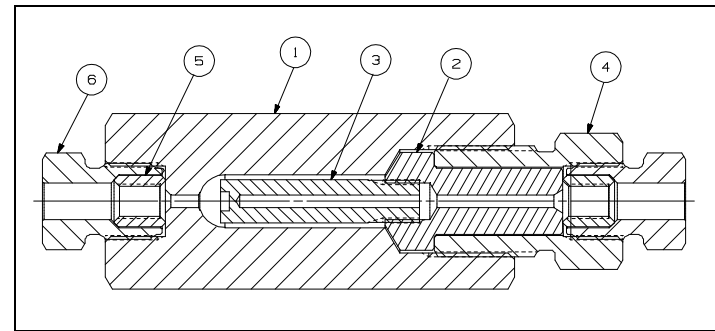

Figure 12-34B: HP Inline Water Filter, .38

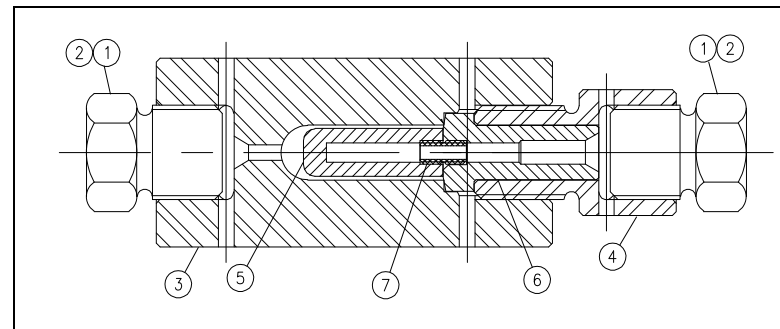

Table 12-34
High Pressure Water Filter Assemblies

Item	Part Number	Description	Quantity
	BF103473	Inline Water Filter, .56	
1	AF413972	HP Gland, Outlet	1
2	AF303473	Seal Head, Outlet	1
3	AF503473	Filter Element	1
4	BF203473	Filter Body	1
5	AF913972	HP Gland, Inlet	1
6	10074599	O-Ring, .38 x .50 x .06	1
7	AF403473	Seal Head, Inlet	1

Figure 12-34C: HP Inline Water Filter, .56

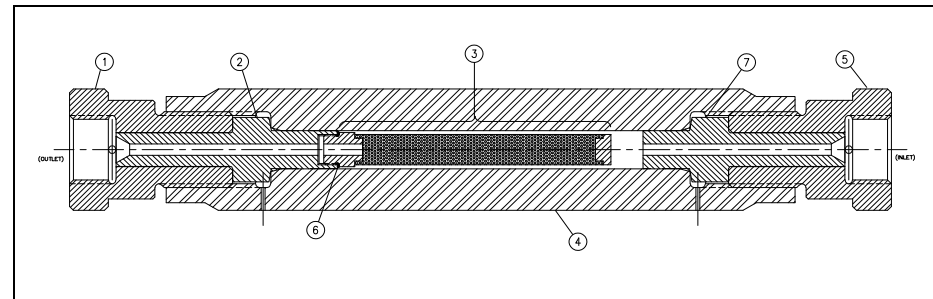

Table 12-35
High Pressure Swivel Joints

Item	Part Number	Description	Quantity
	CJ211388	HP Swivel Joint, Straight, .25, M/F	
1	10084713	Thrust Needle Bearing	1
2	10094647	Thrust Washer	2
3	10103505	Setscrew, 6-32 x 1/8	1
4	CJ311388	Swivel Body	1
5	CJ401288	Swivel Bushing	1
6	CJ501288	Spindle, .25	1
7	BJ701288	Cap Assembly	1
8	BJ201388	Seal Assembly	1
	BJ701288	Cap Assembly	
1	CJ801288	Cap, .25/.38, M/F	1
2	10144442	Swivel Bushing	1

Figure 12-35A: HP Swivel Joint, Straight, M/F Connection, .25

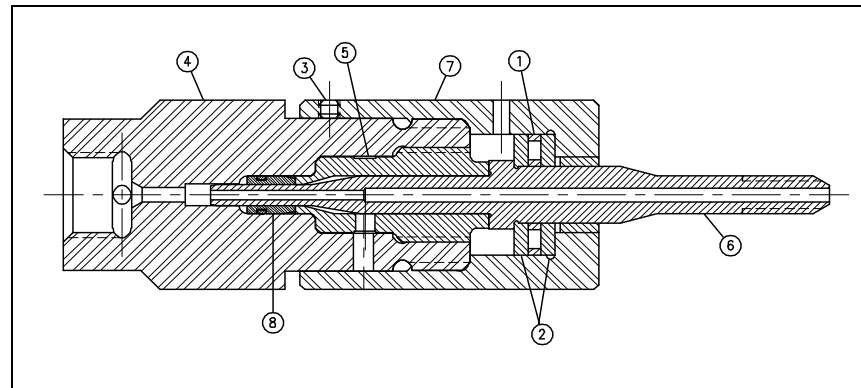

Table 12-35
High Pressure Swivel Joints

Item	Part Number	Description	Quantity
	CJ218088	HP Swivel Joint, Straight, .25, F/F	
1	10084713	Thrust Needle Bearing	1
2	10094647	Thrust Washer	2
3	10103505	Setscrew, 6-32 x 1/8	1
4	10154680	Clamp Collar	1
5	CJ318088	Spindle, .56	1
6	CJ418088	Cap, .25	1
7	CJ311388	Swivel Body	1
8	CJ401288	Swivel Bushing	1
9	BJ201388	Seal Assembly	1

Figure 12-35B: HP Swivel Joint, Straight, F/F Connection, .25

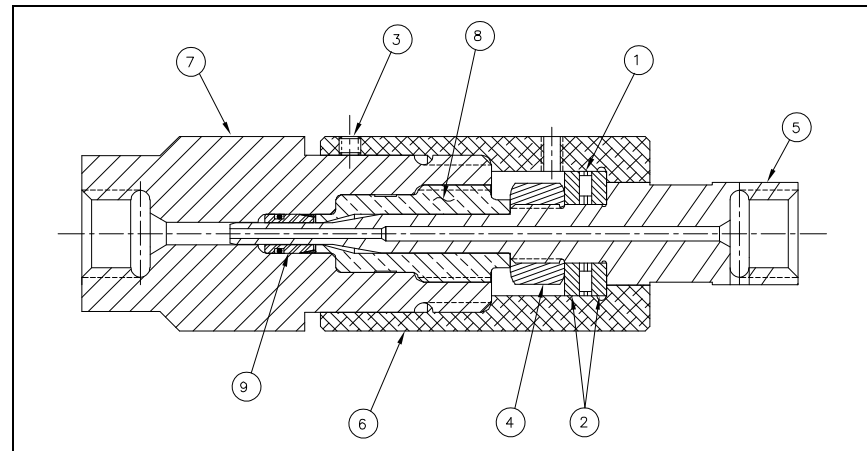

Table 12-35
High Pressure Swivel Joints

Item	Part Number	Description	Quantity
	10134708	HP Swivel Joint, Straight, .38, M/F	
1	10084713	Thrust Needle Bearing	1
2	10094647	Thrust Washer	2
3	10103505	Setscrew, 6-32 x 1/8	1
4	10134716	Swivel Body	1
5	CJ401288	Swivel Bushing	1
6	49899602	Spindle, .38	1
7	BJ701288	Cap Assembly	1
8	BJ201388	Seal Assembly	1
9	10078913	HP Gland, Anti-Vibration	2
10	10078715	HP Collar	2

Figure 12-35C: HP Swivel Joint, Straight, M/F Connection, .38

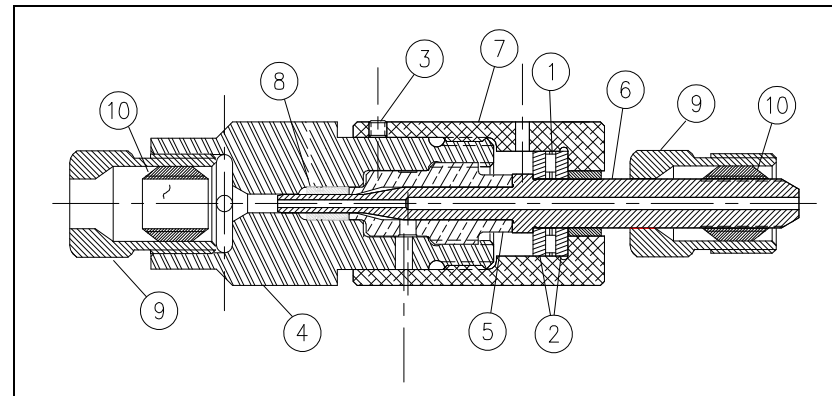

Table 12-35
High Pressure Swivel Joints

Item	Part Number	Description	Quantity
------	-------------	-------------	----------

	CJ201288	HP Swivel Joint, 90D, .25, M/F	
1	10084713	Thrust Needle Bearing	1
2	10094647	Thrust Washer	2
3	10103505	Setscrew, 6-32 x 1/8	1
4	DJ301288	Swivel Body	1
5	CJ401288	Swivel Bushing	1
6	CJ501288	Spindle, .25	1
7	BJ701288	Cap Assembly	1
8	BJ201388	Seal Assembly	1

Figure 12-35D: HP Swivel Joint, 90D, M/F Connection, .25

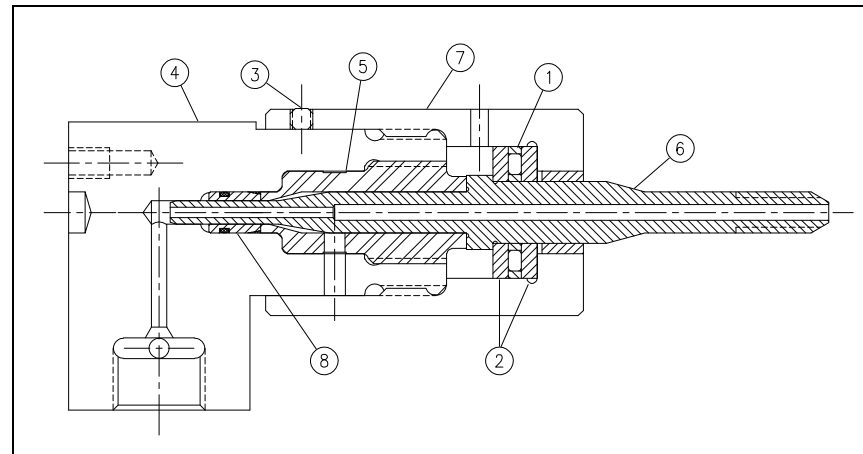

Table 12-35
High Pressure Swivel Joints

Item	Part Number	Description	Quantity
	CJ218188	HP Swivel Joint, 90D, .25, F/F	
1	10084713	Thrust Needle Bearing	1
2	10094647	Thrust Washer	2
3	10103505	Setscrew, 6-32 x 1/8	1
4	10154680	Clamp Collar	1
5	CJ318088	Spindle, .56	1
6	CJ418088	Cap, .25	1
7	DJ301288	Swivel Body	1
8	CJ401288	Swivel Bushing	1
9	BJ201388	Seal Assembly	1

Figure 12-35E: HP Swivel Joint, 90D, F/F Connection, .25

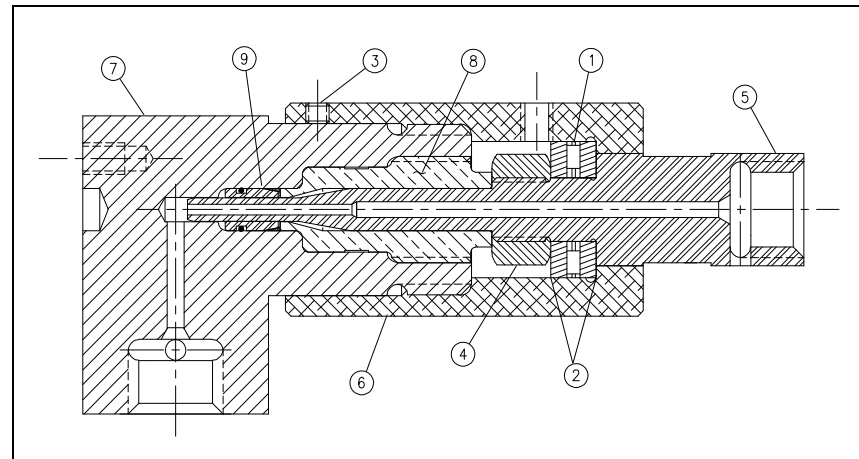

Table 12-35
High Pressure Swivel Joints

Item	Part Number	Description	Quantity
	10134682	HP Swivel Joint, 90D, .38, M/F	
1	10084713	Thrust Needle Bearing	1
2	10094647	Thrust Washer	2
3	10103505	Setscrew, 6-32 x 1/8	1
4	10134690	Swivel Body	1
5	CJ401288	Swivel Bushing	1
6	49899602	Spindle, .38	1
7	BJ701288	Cap Assembly	1
8	BJ201388	Seal Assembly	1
9	10078913	HP Gland, Anti-Vibration	2
10	10078715	HP Collar	2

Figure 12-35F: HP Swivel Joint, 90D, M/F Connection, .38

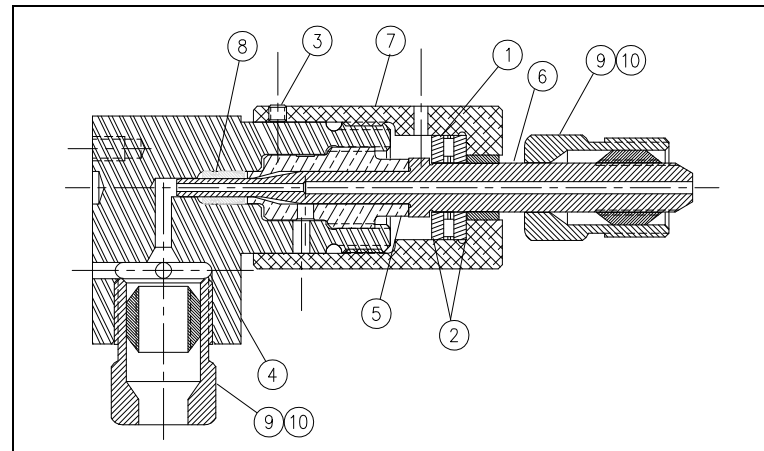

Table 12-36
3/8" Nozzle Tubes

Part Number	Description		Part Number	Description			
	Actual in (mm)	Nominal in (mm)		Actual in (mm)	Nominal in (mm)		
10181113	2.65 (67.31)	3.00 (76.20)	10138451	8.65 (219.71)	9.00 (228.60)	<p><i>Figure 12-36A: .38 Nozzle Tube, Nozzle Nut Connection</i></p> 	
10138402	3.65 (92.91)	4.00 (101.60)	05136023	9.15 (232.41)	9.50 (241.30)		
10138410	4.65 (118.11)	5.00 (127.0)	10138469	9.65 (245.11)	10.00 (254.0)		
10138428	5.65 (143.51)	6.00 (152.40)	05106224	10.15 (257.81)	10.50 (266.70)		
05131784	5.91 (150.11)	6.25 (158.75)	05136031	10.65 (270.51)	11.00 (279.40)		
10138436	6.65 (168.91)	7.00 (177.80)	05013735	11.65 (295.91)	12.00 (304.80)		
10138444	7.65 (194.31)	8.00 (203.20)	05086913	14.65 (372.11)	15.00 (381.0)		
05106224	8.10 (205.74)	8.45 (214.63)					
10138584	3.64 (92.46)	4.00 (101.60)	10138634	7.64 (194.06)	8.00 (203.20)		<p><i>Figure 12-36B: .38 Nozzle Tube, HP Connection</i></p> 
10138592	4.64 (117.86)	5.00 (127.0)	10138642	8.64 (219.46)	9.00 (228.60)		
10138600	5.64 (143.26)	6.00 (152.40)	10138659	9.64 (244.86)	10.00 (254.0)		
10138618	6.64 (168.66)	7.00 (177.80)	20432414	13.64 (346.46)	14.00 (355.60)		

Table 12-36
9/16" Nozzle Tubes

Part Number	Description		Part Number	Description		
	Actual in (mm)	Nominal in (mm)		Actual in (mm)	Nominal in (mm)	
10138477	2.65 (67.31)	3.00 (76.20)	10138527	7.65 (194.31)	8.00 (203.20)	<p><i>Figure 12-36C: .56 Nozzle Tube, Nozzle Nut Connection</i></p> 
10138485	3.65 (92.91)	4.00 (101.60)	10138535	8.65 (219.71)	9.00 (228.60)	
10138493	4.65 (118.11)	5.00 (127.0)	10181105	9.65 (245.11)	10.00 (254.0)	
10138501	5.65 (143.51)	6.00 (152.40)	10193100	11.65 (295.91)	12.00 (304.80)	
10138519	6.65 (168.91)	7.00 (177.80)				
10138667	3.65 (92.91)	4.00 (101.60)	10138709	7.65 (194.31)	8.00 (203.20)	<p><i>Figure 12-36D: .56 Nozzle Tube, HP Connection</i></p> 
10138675	4.65 (118.11)	5.00 (127.0)	10138717	8.65 (219.71)	9.00 (228.60)	
10138683	5.65 (143.51)	6.00 (152.40)	10138725	9.65 (245.11)	10.00 (254.0)	
10138691	6.65 (168.91)	7.00 (177.80)	80074446	10.65 (270.51)	11.00 (279.40)	

Table 12-37
Autoline™ Abrasive Nozzle Assembly

Item	Part Number	Description	Quantity
	05078530	Autoline™ Nozzle Assembly, .030 Wear Insert	
	05147970	Autoline™ Nozzle Assembly, .043 Wear Insert	
1	05076971	Nozzle Cap	1
2	05073820	Nozzle Body	1
3	05076955	Wear Insert, .030 x .156	1
	05135827	Wear Insert, .043 x .156	
4	05076989	Feed Tube Adapter	1
5	05077292	Setscrew, 1/4-28	1
6	05081518	O-Ring, .38 x .50 x .06	1
7	05104930	O-Ring, .50 x .63 x .06	2
8	05092887	O-Ring, .75 x .63 x .06	1
9	05078712	Retainer Knob	1
10	05087168	Guard	1
	49885361	Poly Tube, .38	

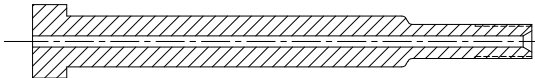
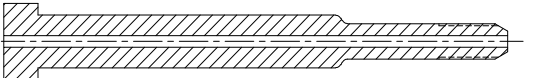
Figure 12-37: Autoline™ Abrasive Nozzle Assembly

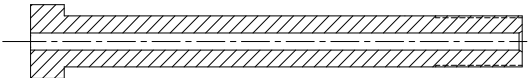
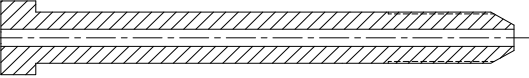
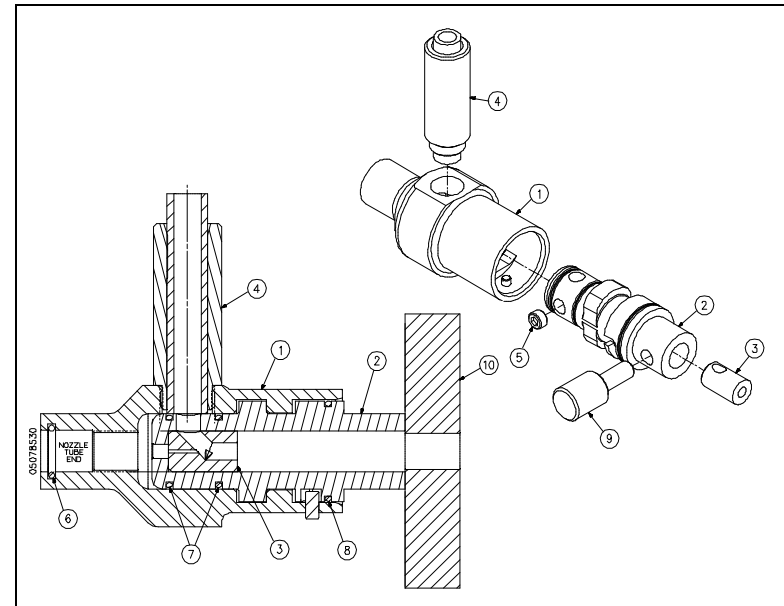

Table 12-38
Autoline II™ Abrasive Nozzle Assembly

Item	Part Number	Description	Quantity
	20453949	Autoline II™ Nozzle Assembly, .030 Wear Insert	
	20454108	Autoline II™ Nozzle Assembly, .043 Wear Insert	
1	20453952	Nozzle Cap	1
2	20453958	Nozzle Body	1
3	20453064	Wear Insert, .030 x .156	1
	20453082	Wear Insert, .043 x .156	
4	20453964	Feed Tube Assembly	1
5	20453973	Handle	1
6	20433398	Setscrew, 8-32	1
7	20453976	T-Knob	1
8	05138821	O-Ring, .69 x .81 x .06	1
9	20445476	O-Ring, .31 x .44 x .06	1
10	05087168	Guard	1
11	05081518	O-Ring, .38 x .50 x .06	1
12	05077078	O-Ring, .38 x .50 x .06	1
	49885361	Poly Tube, .38	

Figure 12-38: AutolineII™ Abrasive Nozzle Assembly

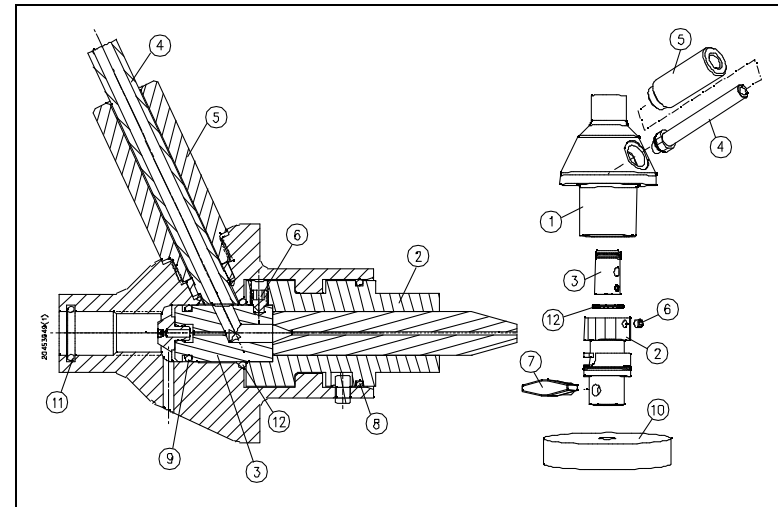

Table 12-39
Autoline™ Diamond Orifice

Part Number	Description	Part Number	Description
20448625	0.004" (0.102 mm)	05136098	0.013" (0.330 mm)
05063847	0.007" (0.178 mm)	05077037	0.014" (0.356 mm)
05112537	0.008" (0.203 mm)	80075781	0.015" (0.381 mm)
05084504	0.009" (0.229 mm)	05121512	0.016" (0.406 mm)
05077029	0.010" (0.254 mm)	05114905	0.018" (0.457 mm)
05101753	0.011" (0.279 mm)	80086663	0.019" (0.482 mm)
05077300	0.012" (0.305 mm)	05114897	0.020" (0.508 mm)

Figure 12-39: Autoline™ Diamond Orifice

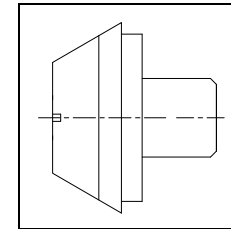

Table 12-40
Autoline™ Sapphire Orifice

Part Number	Description	Part Number	Description
05109079	0.007" (0.178 mm)	20412569	0.013" (0.330 mm)
05109087	0.008" (0.203 mm)	05109137	0.014" (0.356 mm)
05109095	0.009" (0.229 mm)	20448541	0.016" (0.406 mm)
05109103	0.010" (0.254 mm)	05114913	0.018" (0.457 mm)
05109111	0.011" (0.279 mm)	80086671	0.019" (0.482 mm)
05109129	0.012" (0.305 mm)	05114921	0.020" (0.508 mm)

Figure 12-40: Autoline™ Sapphire Orifice

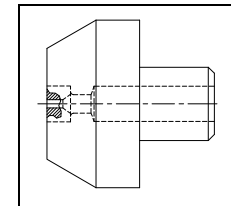

Table 12-41
Pneumatic Control Valve, Normally Closed
10138824

Item	Part Number	Description	Quantity
------	-------------	-------------	----------

1	10177855	Pneumatic Actuator Assembly, NC	1
2	10189181	Valve Body	1
3	BV701184	HP Gland	1
4	10188233	Brass Backup Ring	1
5	20428052	Seal Assembly	1
6	20435636	Valve Stem	1
7	10178697	Valve Seat	1

Figure 12-41: Pneumatic Control Valve, NC

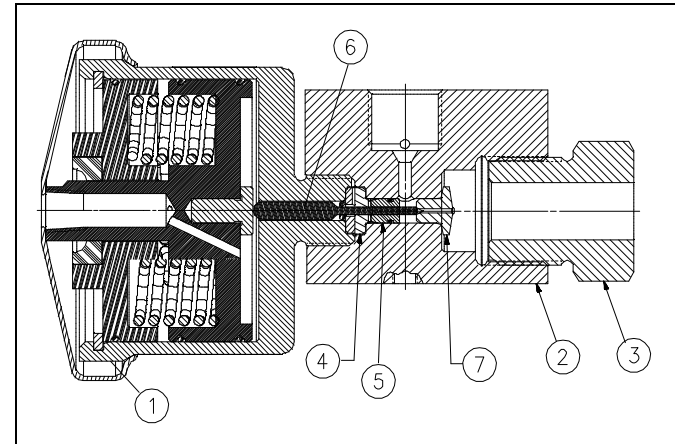

Table 12-42
Pneumatic Actuator Assembly, Normally Closed
10177855

Item	Part Number	Description	Quantity
1	05145990	Piston	1
2	20411554	Cylinder Cap	1
3	10177780	Wiper Seal	1
4	10177772	Retaining Ring	1
5	10176543	Pneumatic Cylinder	1
6	10177806	O-Ring, 2.63 x 2.75 x .06	3
7	05054119	Compression Spring, .72 x .105 x 1.50	6
8	49895584	O-Ring, .08 x .20 x .06	1
9	10187250	SST Backup Ring	1
10	00080028	Cover	1
	10178291	Warning Decal	

Figure 12-42: Pneumatic Actuator Assembly, NC

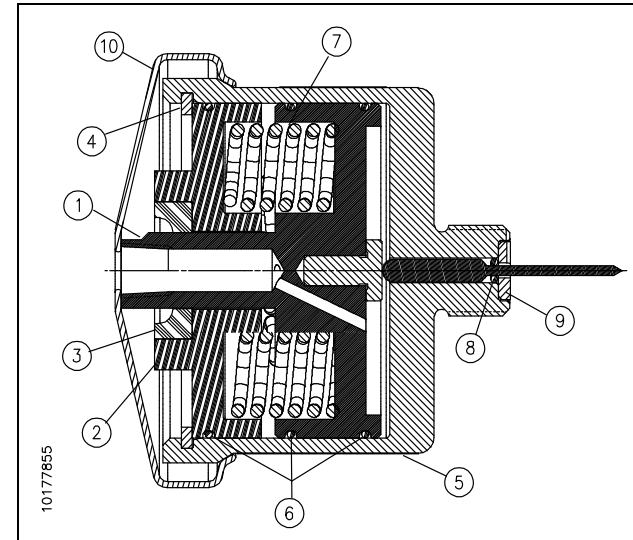

Table 12-43
Pneumatic Control Valve, Normally Open
10184760

Item	Part Number	Description	Quantity
------	-------------	-------------	----------

1	10189553	Pneumatic Actuator Assembly	1
2	10189181	Valve Body	1
3	BV701184	HP Gland Fitting	1
4	10188233	Brass Backup Ring	1
5	20428052	Seal Assembly	1
6	20435636	Valve Stem	1
7	10178697	Valve Seat	1

Figure 12-43: Pneumatic Control Valve, NO

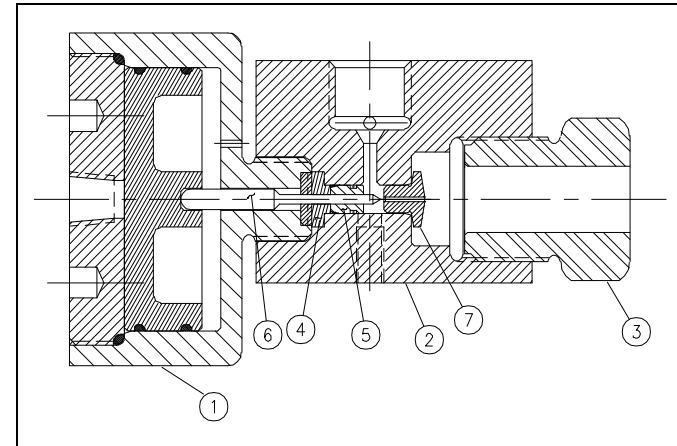
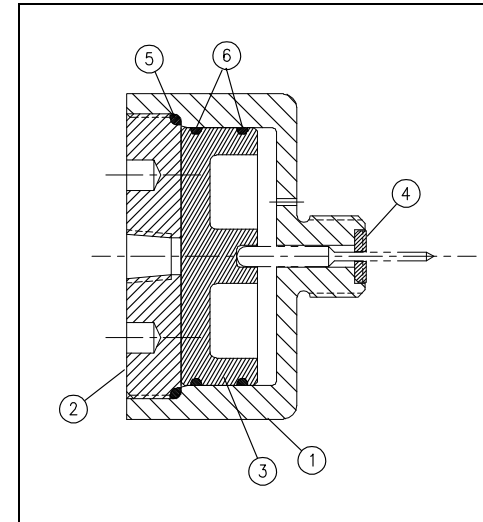

Table 12-44
Pneumatic Actuator Assembly, Normally Open
10189553

Item	Part Number	Description	Quantity
1	BV401184	Pneumatic Cylinder	1
2	BV601184	Cylinder Head	1
3	BV501184	Piston	1
4	10187250	SST Backup Ring	1
5	10074714	O-Ring, 2.44 x 2.63 x .09	1
6	10074565	O-Ring, 2.25 x 2.38 x .06	2

Figure 12-44: Pneumatic Actuator Assembly, NO



REVISIONS			
NO	DESCRIPTION	DATE	APPROVED
1	DELETED GAGE ON LP MANIFOLD, ADDED OPTION NOTATION REF ECR REV03/17	3/20/06	JJS
2	DELETED BALL AND CHECK VALVES ON LP FLIER ASSY REF ECR REV03/60	10/19/06	JJS

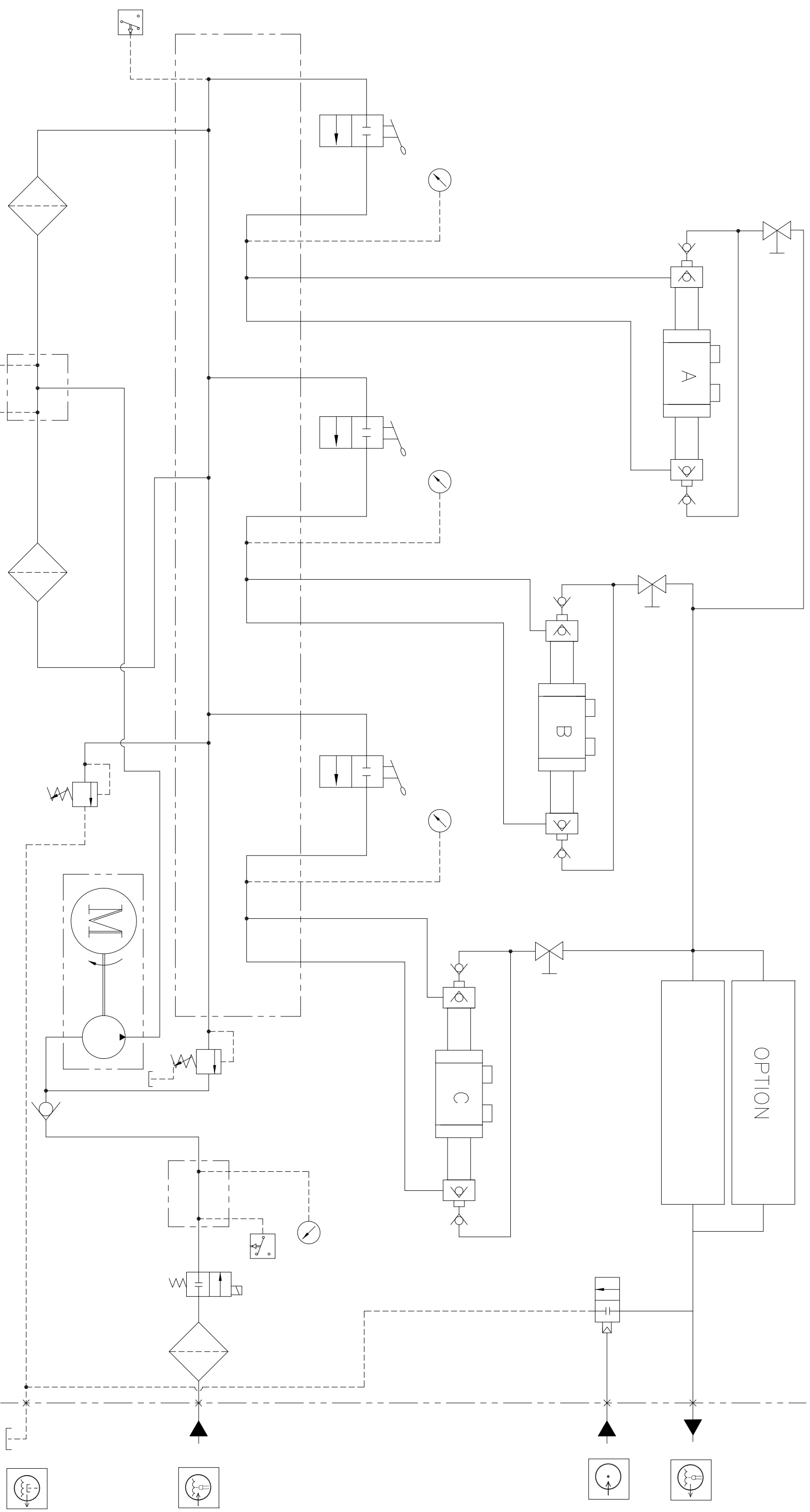

Copyright © 2003 KMT Waterjet Systems All Rights Reserved		PROPRIETARY NOTICE		STANDARD TOLERANCES UNLESS OTHERWISE NOTED:		GD&T TO ASME Y14.5M 1994		TITLE	
WARNING ! The export or reexport of this drawing or a product produced by this drawing is prohibited by U.S. Export Administration regulations and other applicable governmental restrictions or regulations.		This document contains confidential and trade secret information and is intended to be used only by the person to whom it is given and retention of the document accepts the document in confidence and agrees that, except as authorized in writing, the information contained herein shall be held confidential on any copy thereof; (2) not copy the document; (3) not disclose to others either the document or the confidential or trade secret information therein; and (4) upon demand return the document, all copies thereof, and all material copied therefrom.		ALL DIMENSIONS ON COMMON CENTERLINE COAXIAL TO .005 BREAK SHARP EDGES AND CORNERS .015 SURFACE FINISH 6.3 XXX = ±.015 XXX = ±.015 ANGLE = ±2°		MATERIAL — HEAT TREAT — HARDNESS —		DRAWN BY & DATE J. Miller 8/1/05	
KMT Waterjet Systems		49933622		J. Miller 8/1/05		CHECKED BY DATE H. Shields 5/02		ENC. APPROVAL & DATE —	
SCHEMATIC-CUTTING WTR		150/200 HP		20433099D		THIRD ANGLE PROJECTION		TITLE BLOCK REGION: 1	
SCALE: —		SHEET 1 OF 1		REV. 2		—		—	

REVISIONS			
NO	DESCRIPTION	DATE	APPROVED
1	SWITCHED POSITIONS OF OUTER FUNCTION GAGE TO FILTER ADDED DRIVE TO SECOND PUMP. REF ECR REV03417	3/22/06 JOS	3/22/06 JOS
2	REVERSED COOLING WATER IN AND COOLING WATER OUT. REF ECR REV054465	7/23/10 JMiller	7/23/10 JOS

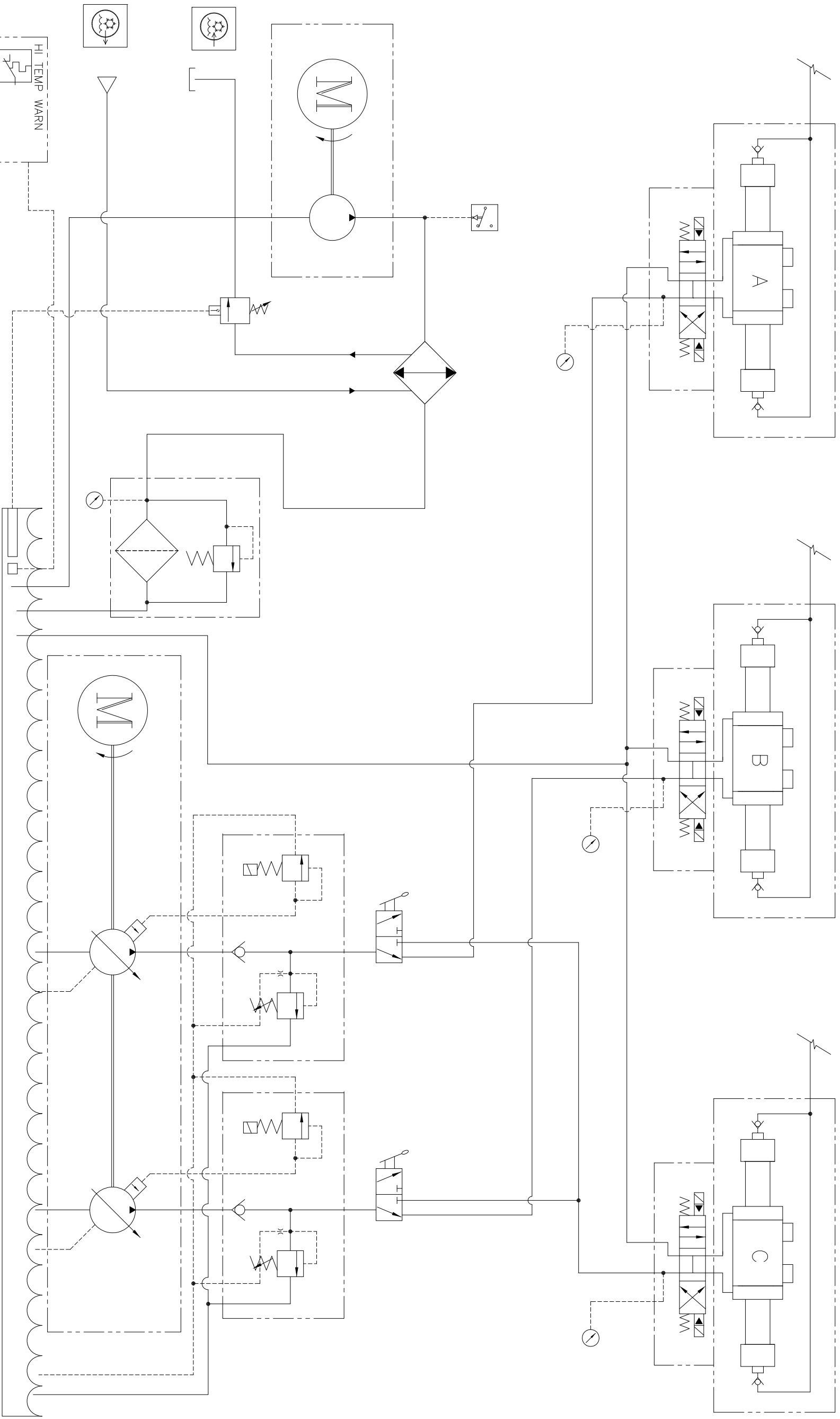

<p>Copyright © 2003 KMT Waterjet Systems All Rights Reserved</p>	<p>PROPRIETARY NOTICE</p> <p>This document contains confidential and trade secret information and is intended for the use of the recipient only. The recipient of this document agrees that, except as authorized in writing by KMT Waterjet Systems, it will not disclose, copy, or otherwise use the information contained herein for any purpose other than the specific purpose for which it was provided. If you are not the intended recipient, you should not disseminate, distribute, or take any action in reliance on the information contained herein. If you have received this document in error, please notify the sender immediately by return email or telephone. Upon demand, return the document, all copies thereof, and all material copied therefrom.</p>	<p>STANDARD TOLERANCES</p> <p>UNLESS OTHERWISE NOTED:</p> <p>ALL DIMENSIONS ON COMMON CENTRELINE COARD TO .005 BREAK SHARP EDGES AND CORNERS .015 SURFACE FINISH -- 7 XXX = ±.015 XXX = ±.005 ANGLE = ±2°</p>	<p>GD&T TO ASME Y14.5M 1994</p> <p>REF. DIMS 499335622 DRAWN BY & DATE J.Miller 8/1/05 CHECKED BY SITE H. Shields 11/05 ENG. APPROVAL & DATE</p>	<p>TITLE</p> <p>SCHEMATIC-HYDR SYS, 150/200 HP</p> <p>FIG. NO. 20433117D</p> <p>SCALE THIRD ANGLE PROJECTION</p> <p>TITLE BLOCK REVISION 2</p> <p>SHEET 1 OF 1</p>
--	---	--	---	---

NEXT ASSEMBLY

REVISIONS			
NO	DESCRIPTION	DATE	APPROVED
1	REV 03382Z REMOVE BOOSTER PUMP	1/29/06	G.P.N./JOS
2	ADDED BOOSTER PUMP	3/27/06	G.P.N./JOS
3	REV ECR REV03500	7/14/06	G.P.N./JOS
4	ADD FUSES IF CSA	7/14/06	G.P.N./JOS
5	REV ECR REV03857	9/9/08	G.P.N./JOS
6	2.5A BREAKER WAS 3A	9/9/08	G.P.N./JOS
7	REV ECR REV04723	10/29/10	G.P.N./JOS
8	CHANGED SOFTSTARTER REL ECR REV05273	4/28/10	G.P.N./JOS

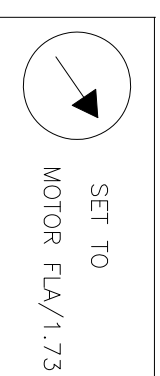
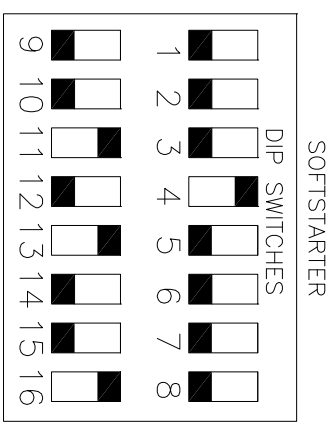
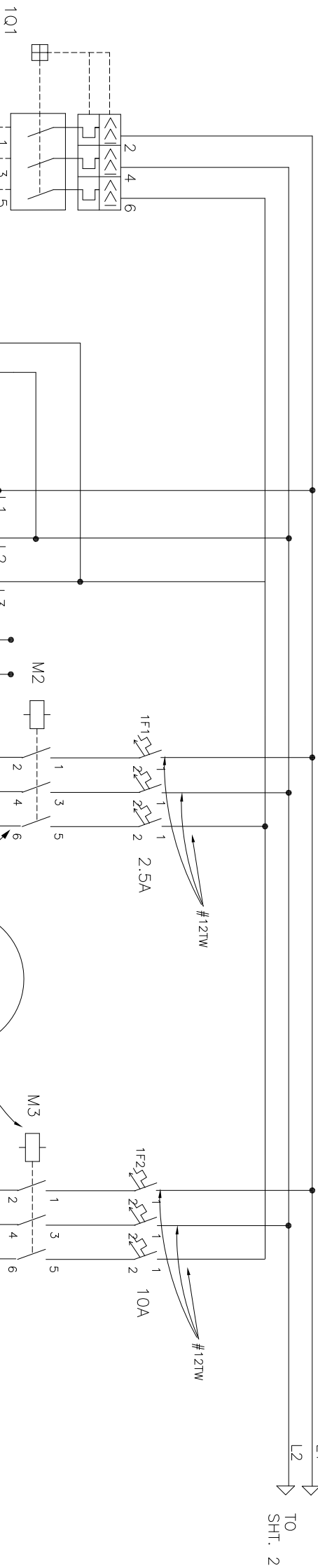

MOTOR FLA

HP \ VOLTAGE	400	460	575
150	221	180	144
200	285	240	192

MOTOR TERMINATION

CONNECT	L1	L2	L3	T1	T2	T3
HIGH VOLTAGE	1	2	3	12	10	11
LOW VOLTAGE	6-12	4-10	5-11	1-7	2-8	3-9

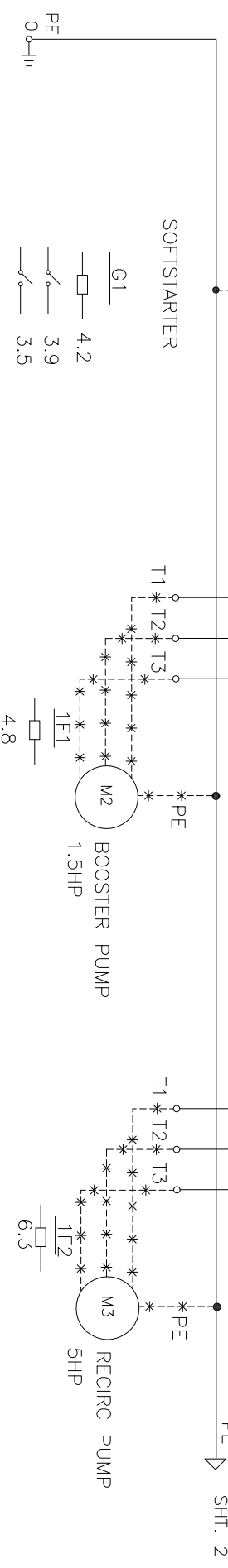

NOTE: ----- WIRING BY CUSTOMER IN ACCORDANCE WITH LOCAL REGULATIONS.
 --*-* WIRING BY KMT EXTERNAL TO PANEL
 ALL AC CONTROL VOLTAGE WIRES MUST BE RED IN COLOR

NOTE: 1. REPLACE BREAKER WITH FUSES ON CSA PANELS ONLY.

Copyright © 2003 KMT Waterjet Systems All Rights Reserved

PROPRIETARY NOTICE: This document contains confidential and trade secret information, is the property of KMT Waterjet Systems, and its disclosure to any other person without the written consent of KMT Waterjet Systems is prohibited. (1) not disclose the document or its contents to any other person; (2) not copy the document or its contents; (3) not disclose to others either the document or its contents or the information contained therein; (4) not use the information contained herein for any purpose other than that for which it was intended; (5) upon demand return the document, or all material copied therefrom.

STANDARD TOLERANCES UNLESS OTHERWISE NOTED: GD&T TO ASME Y14.5M 1994

ALL DIMENSIONS IN INCHES [mm]	DRAWN BY & DATE	REF. DWG	TITLE
WATERJET	G.P.N. 5/03	-	SCHEM-ELEC, 150/200 HP
BREAK SWAMP EDGES AND CORNERS 015	CHECKED BY DATE		
HEAT TREAT	G.P.N. 01/06		
	APPROVED BY DATE		
	G.P.N. 03/06		

SCALE: - THIRD ANGLE PROJECTION

REV. 9

20423970D

20423970D SHEET 1 OF 6

REVISIONS		DATE	APPROVED
NO.	DESCRIPTION	DATE	APPROVED
6	TRANSFORMER CONNECTIONS MODIFIED PER ECR REV04606.	5/22/08 DCM	5/22/08 JDS

DWG. NO. 20433970D
SHEET 2 OF 9

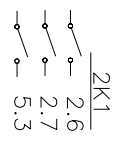
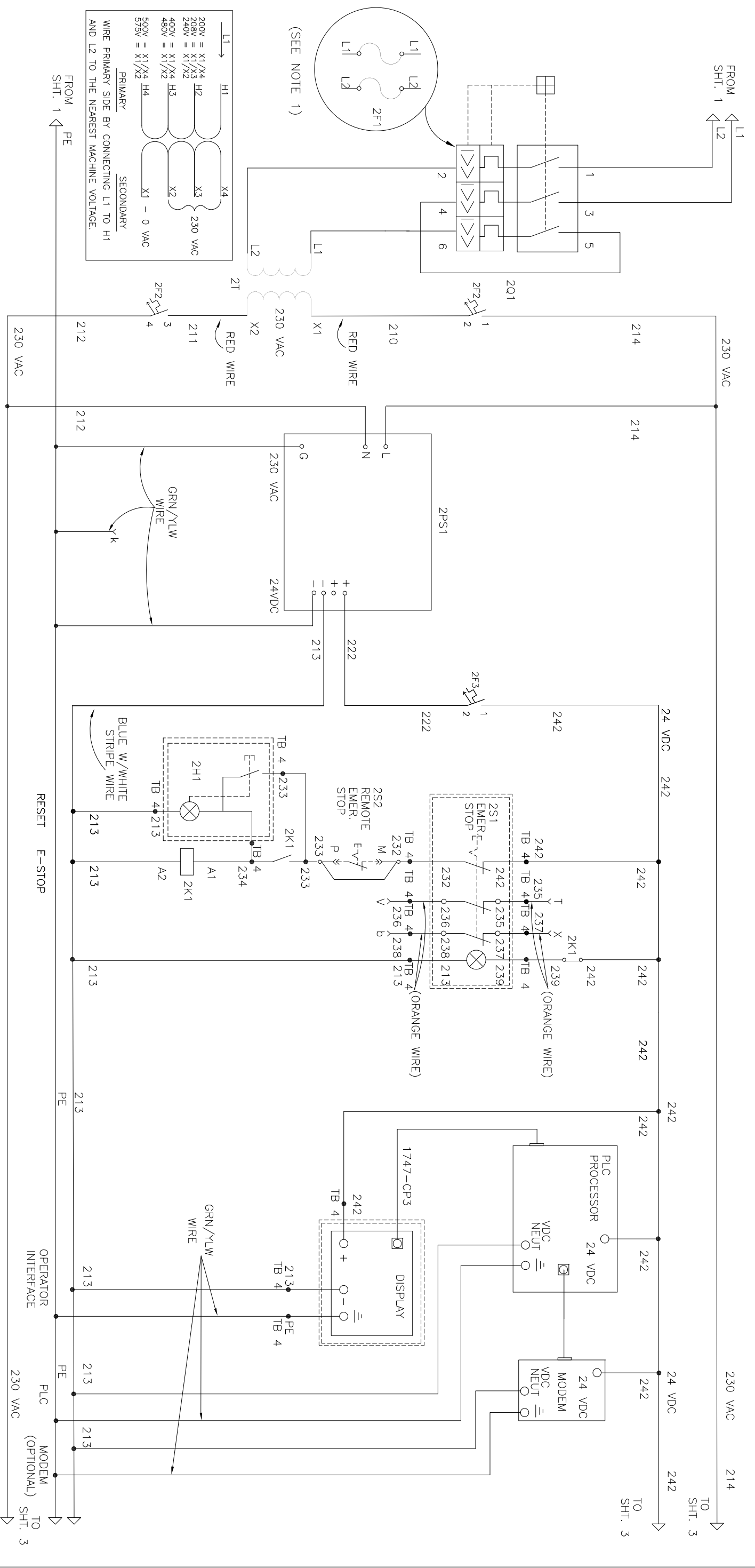

NOTE: 1. REPLACE BREAKER WITH FUSES ON CSA PANELS ONLY.

- WIRING BY CUSTOMER IN ACCORDANCE WITH LOCAL REGULATIONS.
- *---*---*--- WIRING BY KMT EXTERNAL TO PANEL
- DEVICES IN REMOTE CONTROL PANEL
- ALL AC CONTROL VOLTAGE WIRES MUST BE RED IN COLOR

Copyright © 2003 KMT Waterjet Systems All Rights Reserved	PROPRIETARY NOTICE	STANDARD TOLERANCES UNLESS OTHERWISE NOTED: GD&T TO ASME Y14.5M 1994	REF. DWG. -	DRAWN BY & DATE G.P.N. G.P.N.	CHECKED BY & DATE G.P.N. G.P.N.	DATE APPROVAL & DATE G.P.N. 03/06	SCALE: -	THIRD ANGLE PROJECTION	DWG. NO. 20423970D	TITLE SCHEM-ELEC, 150/200 HP	REV. 9
WARNING ! The export or reexport of this document, or any information contained herein, is prohibited by the U.S. Export Administration Regulations and other applicable governmental restrictions or regulations.	This document contains confidential and trade secret information, is the property of KMT Waterjet Systems, and is loaned to you for your use only. It is not to be distributed, copied, or otherwise used in any way without the prior written consent of KMT Waterjet Systems. If you are not an authorized user, you are notified that this document contains confidential and trade secret information. (1) not disclose the document or the information contained herein to any other person; (2) not copy the document or the information contained herein; (3) not remove the document or the information contained herein from the premises of KMT Waterjet Systems; and (4) upon demand return the document, all copies thereof, and all material copied therefrom.	ALL DIMENSIONS IN INCHES [mm] WATERJET HEAT TREAT FINISH 63							KMT Waterjet		

REVISIONS			
NO.	DESCRIPTION	DATE	APPROVED
1	ADDED SOFT STARTER REF FOR REV03132	6/1/05 S.M.H	6/1/05 G.P.N.
9	ADDED 2P-RSS TOGGLE INPUT 15 REF FOR REV05494	8/27/10 KB	8/27/10 KB

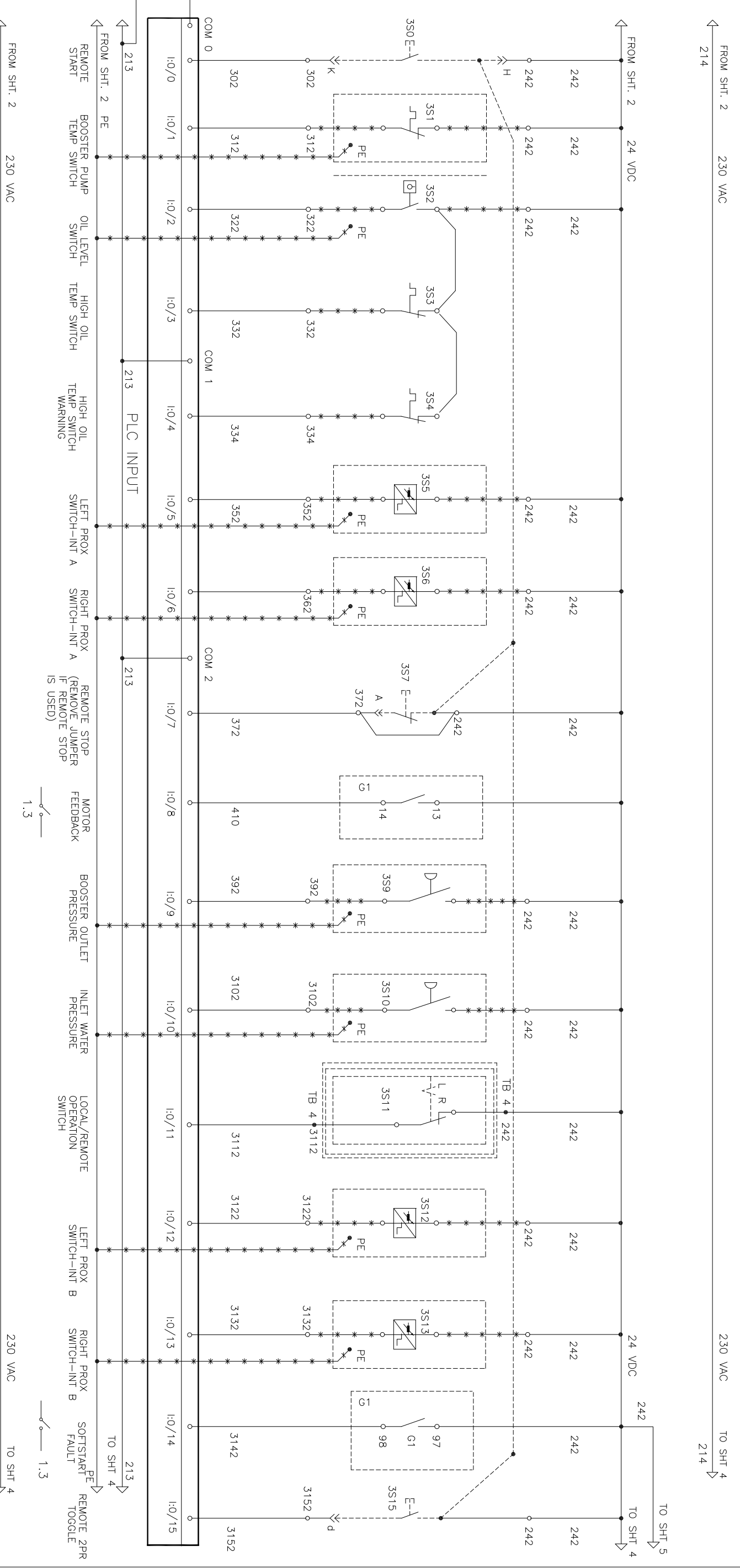

212 FROM SHT. 2 230 VAC TO SHT. 4 214

212 FROM SHT. 2 230 VAC TO SHT. 4 214

WIRING BY CUSTOMER IN ACCORDANCE WITH LOCAL REGULATIONS

WIRING BY KMT EXTERNAL TO PANEL

DEVICES IN REMOTE CONTROL PANEL

ALL AC CONTROL VOLTAGE WIRES MUST BE RED IN COLOR

Copyright © 2003 KMT Waterjet Systems All Rights Reserved		PROPRIETARY NOTICE		STANDARD TOLERANCES UNLESS OTHERWISE NOTED: COMMON CENTRAL LINE DIMENSIONS TO .005 BREAK SHARP EDGES AND CORNERS .015 HEAT TREAT G.P.N. CHECKED 5/2/05 G.P.N. DATE 03/06		GD&T TO ASME Y14.5M 1994		DRAWN BY & DATE G.P.N. DATE 01/06		SCALE: THIRD ANGLE PROJECTION	
WARNING ! The export or reexport of this drawing is prohibited by U.S. Export Administration regulations and other applicable governmental restrictions or regulations.		This document contains confidential and trade secret information, is the property of KMT Waterjet Systems, and is intended for the use of the recipient only. The recipient shall not disclose this information to any third party without the prior written consent of KMT Waterjet Systems. If you are not an authorized recipient, you are notified that disclosing, copying, distributing, taking action in reliance on, or taking any action in reliance on the information contained in this document is strictly prohibited.		UNLESS OTHERWISE NOTED: COMMON CENTRAL LINE DIMENSIONS TO .005 BREAK SHARP EDGES AND CORNERS .015 HEAT TREAT G.P.N. CHECKED 5/2/05 G.P.N. DATE 03/06		GD&T TO ASME Y14.5M 1994		DRAWN BY & DATE G.P.N. DATE 01/06		SCALE: THIRD ANGLE PROJECTION	
KMT Waterjet		SCHEM-ELEC, 150/200 HP		DWG. NO. 20423970D		DATE 03/06		REV. 9		SHEET 3 OF 6	

NO.	DESCRIPTION	DATE	APPROVED

DWG. NO. 20433970D
 SHEET 4 OF 9

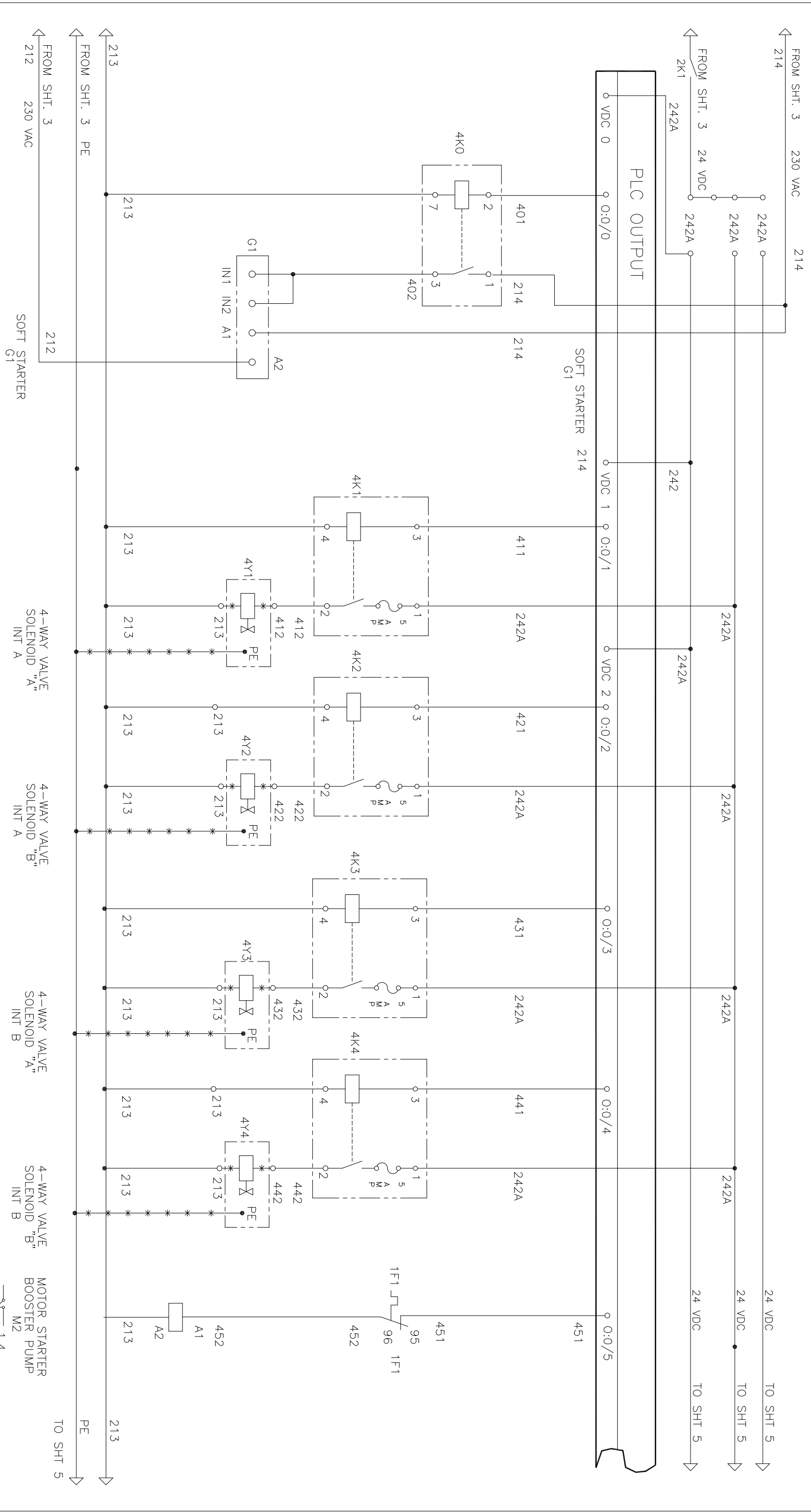

WIRING BY CUSTOMER IN ACCORDANCE WITH LOCAL REGULATIONS
 WIRING BY KMT EXTERNAL TO PANEL
 ALL AC CONTROL VOLTAGE WIRES MUST BE RED IN COLOR

Copyright © 2003 KMT Waterjet Systems All Rights Reserved	PROPRIETARY NOTICE	STANDARD TOLERANCES UNLESS OTHERWISE NOTED: GD&T TO ASME Y14.5M 1994	REF. DWG. -		TITLE
<p>WARNING !</p> <p>The export or re-export of this drawing or any part thereof is prohibited by the U.S. Export Administration Regulations and other applicable governmental restrictions or regulations.</p>	<p>This document contains confidential and trade secret information, is the property of KMT Waterjet Systems, and is intended for use only by the recipient. The recipient is prohibited from disclosing this information to any third party without the prior written consent of KMT Waterjet Systems. (1) not to use the information for any other purpose; (2) not to copy, reproduce, or disseminate the information; (3) not to disclose to others either the document or the information contained therein; (4) not to use the information for any other purpose; (5) not to use the information for any other purpose; (6) not to use the information for any other purpose; (7) not to use the information for any other purpose; (8) not to use the information for any other purpose; (9) not to use the information for any other purpose; (10) not to use the information for any other purpose.</p>	<p>ALL DIMENSIONS IN INCHES [mm]</p> <p>WATERJET</p> <p>HEAT TREAT</p> <p>DRAWN BY & DATE</p> <p>G.P.N.</p> <p>CHECKED BY & DATE</p> <p>G.P.N.</p>	<p>DATE</p> <p>03/06</p>		<p>SCHEM-ELEC, 150/200 HP</p>
					<p>DWG. NO. 20423970D</p>
					<p>TITLE BLOCK REVISION 2</p>
					<p>SHEET 4 OF 6</p>

NO.	DESCRIPTION	DATE	APPROVED

FROM SHT. 4 24 VDC 242A
 FROM SHT. 4 24 VDC 242A
 FROM SHT. 4 24 VDC 242A
 FROM SHT. 3 24 VDC 242A
 FROM SHT. 3 24 VDC 242A
 FROM SHT. 3 24 VDC 242A
 FROM SHT. 6 24 VDC 242A
 FROM SHT. 6 24 VDC 242A
 FROM SHT. 6 24 VDC 242A

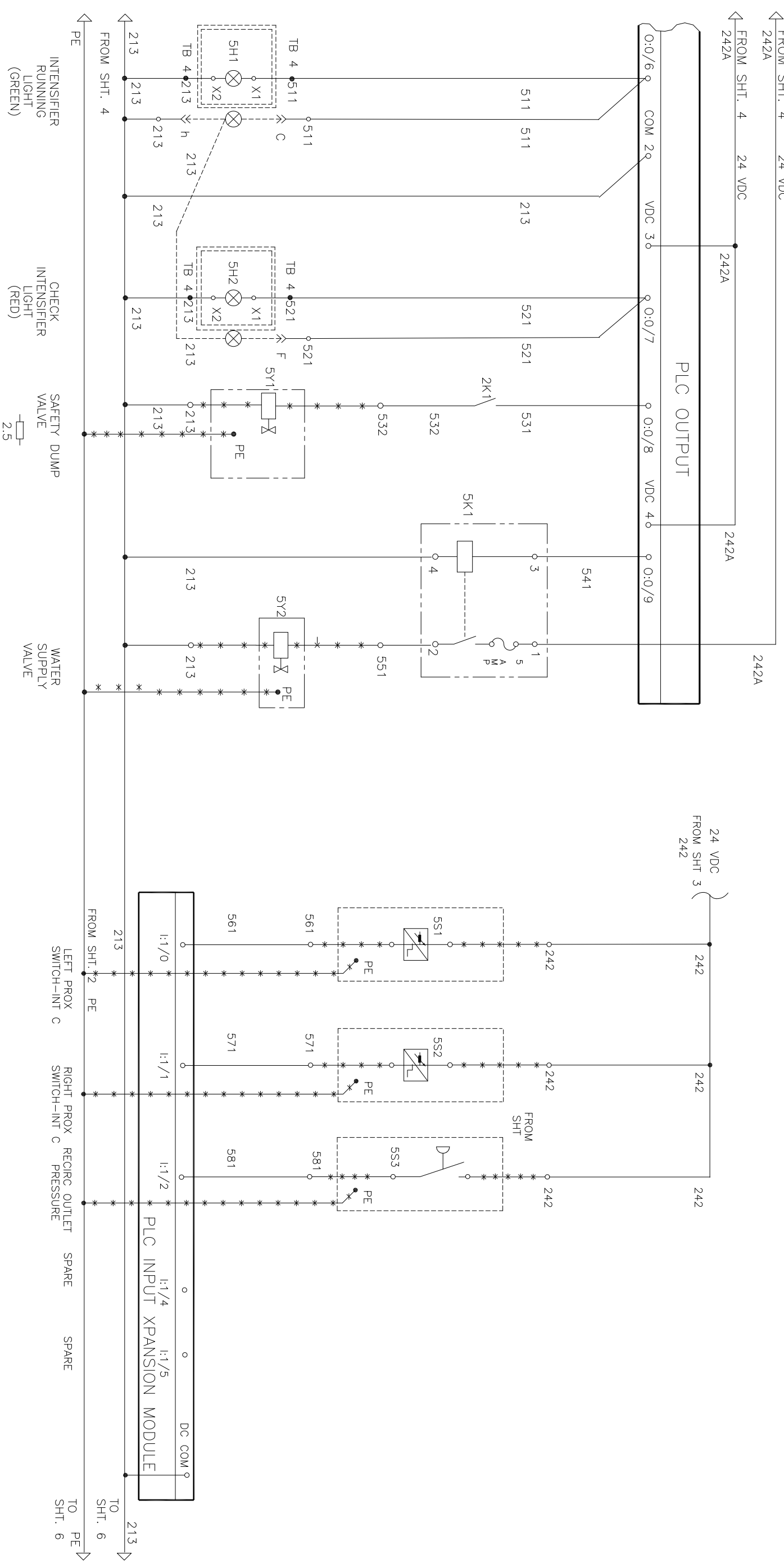

WIRING BY CUSTOMER IN ACCORDANCE WITH LOCAL REGULATIONS

WIRING BY KMT EXTERNAL TO PANEL
 DEVICES IN REMOTE CONTROL PANEL

ALL AC CONTROL VOLTAGE WIRES MUST BE RED IN COLOR

Copyright © 2003 KMT Waterjet Systems All Rights Reserved	PROPRIETARY NOTICE	STANDARD TOLERANCES UNLESS OTHERWISE NOTED: DRAWING BR & DATE G.P.N. CHECKED 5/05 DATE 01/06 G.P.N.	ALL DIMENSIONS IN INCHES [mm]	REF. DIM. -	REF. DIM. 1994 ASME Y14.5M	DATE 03/06	SCALE: -	TITLE SCHEM-ELEC, 150/200 HP	REV. 9
WARNING ! The export or reexport of this drawing is prohibited by the U.S. Export Administration Regulations and other applicable governmental restrictions or regulations.	This document contains confidential and trade secret information, is the property of KMT Waterjet Systems, and is loaned to you for your use only. It is not to be distributed, copied, or otherwise used in any way without the express written permission of KMT Waterjet Systems. If you are not an authorized user, you are notified that the information contained herein is confidential and proprietary to KMT Waterjet Systems. If you are an authorized user, you are notified that the information contained herein is confidential and proprietary to KMT Waterjet Systems. If you are not an authorized user, you are notified that the information contained herein is confidential and proprietary to KMT Waterjet Systems. If you are an authorized user, you are notified that the information contained herein is confidential and proprietary to KMT Waterjet Systems.	HEAT TREAT - FINISH 63 STANDARD TOLERANCES: X.X = ±.063 X.XX = ±.015 X.XXX = ±.005 ANGLE = .42	WATERJET BREAK SHARP EDGES AND CORNERS .015	DATE 03/06	DATE 03/06	DATE 03/06	DATE 03/06	DATE 03/06	DATE 03/06

KMT Waterjet
 SCHEM-ELEC,
 150/200 HP
 20423970D
 SHEET 5 OF 6

REVISIONS		DATE	APPROVED
NO	DESCRIPTION	DATE	APPROVED
1	ADDED RECORD PUMP REF ECR REV03500	3/27/06	JDS
5	ADDED ID TO PROPORTIONAL VALVES REF ECR REV04301	11/27/07	JDS

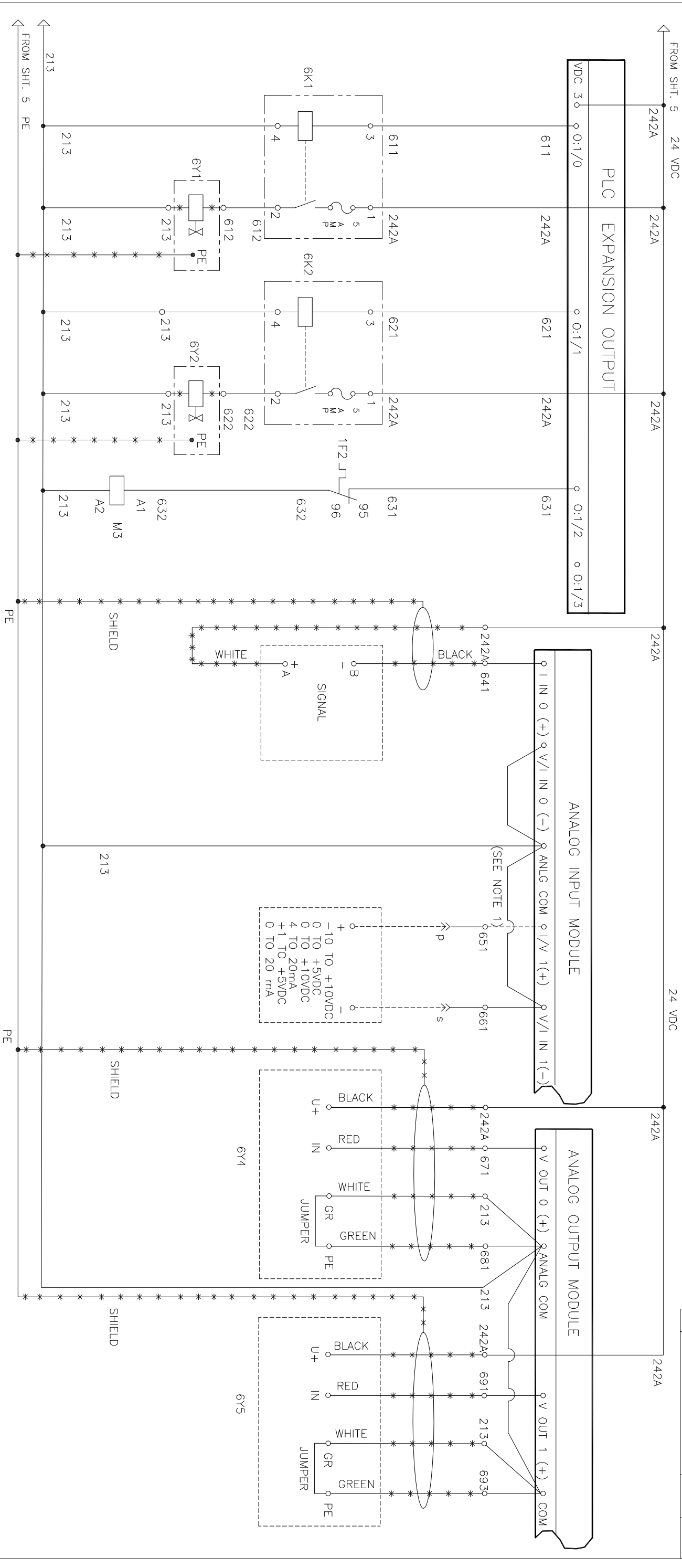

NOTE: VOLTAGE OR CURRENT CONTROL SPECIFIED BY CUSTOMER.
 USE I IN 1(+) FOR CURRENT OR V IN 1(+) FOR
 VOLTAGE CONTROL ON ANALOG MODULE.

----- WIRING BY CUSTOMER IN ACCORDANCE WITH LOCAL REGULATIONS
 ------* WIRING BY KMT EXTERNAL TO PANEL
 ALL AC CONTROL VOLTAGE WIRES MUST BE RED IN COLOR

Copyright © 2003 KMT Waterjet Systems All Rights Reserved	PROPRIETARY NOTICE	STANDARD TOLERANCES UNLESS OTHERWISE NOTED: GD&T TO ASME Y14.5M 1994	REF. DIM. -	KMT Waterjet	TITLE SCHEM-ELEC, 150/200 HP
WARNING ! The export or reexport of this drawing or any information contained herein is prohibited by U.S. Export Administration regulations and other applicable governmental restrictions or regulations.	This document contains confidential and trade secret information, is the property of KMT Waterjet Systems, and its use, reproduction, distribution, or disclosure without the written consent of KMT Waterjet Systems is prohibited. In confidence and agrees that, except as authorized in writing by KMT Waterjet Systems, it will not use, disclose, or disseminate the information contained herein. (3) not disclose to others either the document or the information contained herein, (4) not copy the document, or any information contained therein, (5) not permit the document, or any information contained therein, to be copied, reproduced, or otherwise disseminated without the prior written consent of KMT Waterjet Systems. Upon demand return the document, all copies thereof, and all material copied therefrom.	ALL DIMENSIONS IN INCHES [mm] WATERJET HEAT TREAT FINISH 63 STANDARD TOLERANCES: XX = ±0.03 XXX = ±0.015 ANGLE = ±2°	DRAWN BY & DATE G.P.N. CHECKED BY & DATE G.P.N. ENG. APPROVAL & DATE G.P.N. 03/06	THIRD ANGLE PROJECTION	REV. 9
				SCALE: -	TITLE BLOCK REVISION 2 SHEET 6 OF 6



MATERIAL SAFETY DATA SHEET

PURE GOOP™

November 2003

1. PRODUCT IDENTIFICATION

PURE GOOP: Thread lubricant

Manufactured by:
Swagelok Company
29500 Solon Road
Solon, Ohio USA 44139
Tel: (440) 248-4600
Fax: (440) 349-5970

Emergency Contact:
Chemtrec (800) 424-9300

2. INGREDIENTS

Ingredients	CAS #	WT%	PEL
Polychlorotrifluoroethylene	9002-83-9	75-85	Not Available
Polytetrafluoroethylene	9002-84-0	15-20	Not Available
Amorphous Silica	7631-86-9	1-5	Not Available

3. HEALTH HAZARD INFORMATION

- European Community Danger Group:..... None
- Special Hazards for man or environment: None
- LD₅₀/LC₅₀ Not Available

Routes of Entry

Skin Contact	Skin Absorption	Eye Contact	Inhalation	Ingestion
No	No	Yes	Yes	Yes

4. FIRST AID MEASURES

- If inhaled (Overexposure): If person is affected by fumes, remove person to fresh air. Seek medical attention.
- After contact with skin (Overexposure): Wash thoroughly with soap and water. If severe irritation develops, seek medical attention.
- After contact with eyes: Rinse thoroughly with water for 15 minutes, seek medical attention. Do not rub eyes.
- If swallowed: Seek medical attention.
- Medical information: Unlikely to cause ill effects. Inhaling fumes of decomposition products can cause temporary influenza-like symptoms which are described as “polymer fume fever”. Symptoms include fever, cough, and malaise.

5. FIRE FIGHTING MEASURES



MATERIAL SAFETY DATA SHEET

PURE GOOP™

November 2003

- Suitable extinguishing agents: Carbon dioxide, foam, agent suitable for environment.
- Not suitable for safety reasons: None known.
- Special dangers caused by substance preparation itself, by combustion products or gases formed: May decompose above 500°F/260°C to produce organo-chlorine compounds, organo-fluorine compounds, hydrogen fluoride, and chlorine gas.
- Additional information: None.

Auto ignition	UEL	LEL	Sensitivities
Not Applicable	Not Available	Not Available	Not Available

6. ACCIDENTAL RELEASE MEASURES

- Measures for protection of people: Put on necessary protective equipment. Eye and hand protection as needed.
- Measures for protection of the environment: None required.
- Cleaning measures: Use absorbent material and suitable cleaner.
- Additional information: None.

7. HANDLING AND STORAGE

- Safety information: None.
- Information on protection from fire: May decompose above 500°F/260°C to produce organo-chlorine compounds, organo-fluorine compounds, hydrogen fluoride, and chlorine gas.
- Additional information: Store in a cool, dry place for optimal product performance.

8. EXPOSURE CONTROLS AND PERSONAL PROTECTION

- Precautionary measures to protect employees: None required.
- Respiratory protection: None required.
- Hand protection: Rubber gloves are recommended to minimize exposure.
- Eye protection: Safety glasses or goggles are recommended to minimize exposure.
- Skin protection: Wash hands after use.



MATERIAL SAFETY DATA SHEET

PURE GOOP™

November 2003

9. PHYSICAL AND CHEMICAL PROPERTIES

Appearance Opaque-white	Odor Neutral	pH Not Applicable	Density 2.1 gm/cm ³	Vapor Pressure <0.01mm Hg
Boiling Point Not Available	Melting Point Not Available	Flash Point Not Available	Flammability Not Available	Explosive Not Applicable

10. STABILITY AND REACTIVITY

- Conditions to avoid: May decompose above 500°F/260°C to produce organo-chlorine or compounds, organo-fluorine compounds, hydrogen fluoride, and chlorine gas.
- Materials to avoid: Sodium, potassium, barium, calcium, finely divided zinc, aluminum, magnesium, and beryllium. Avoid aluminum-threaded connections where galling and seizure may initiate a reaction. Reacts with amines, liquid fluorine, and liquid chlorine trifluoride.
- Hazardous decomposition products: See Sections 4 and 5.

11. TOXICOLOGICAL INFORMATION

- Acute toxic properties: None known.
- Health effects: See Sections 4 and 5.
- Additional health effects: None known.

Sensitization	Teratogenicity	Reproductive Toxicity	Mutagenicity	Synergistic Products	Carcinogenicity
Not Available	Not Available	Not Available	Not Available	Not Available	Listed ingredients are not suspected carcinogens according to NTP, and IARC

12. ECOLOGICAL INFORMATION

- Mobility: Paste-like viscosity.
- Degradability: Not established.
- Accumulation: No known adverse bioaccumulation or biomagnification effects.
- Short / Long term effects on ecotoxicity: No known ecological effects.



MATERIAL SAFETY DATA SHEET

PURE GOOP™

November 2003

13. DISPOSAL CONSIDERATIONS

- Appropriate methods of disposal: Unused product not considered a hazardous waste in the United States. Dispose of in a responsible manner.
- European Community(EC) considerations: Use appropriate waste codes based on ingredients.

14. TRANSPORT INFORMATION

- Transport precautions: Consult applicable regulations when transporting this product
- Additional information: None.

15. REGULATORY INFORMATION

- EC regulations: This product has been classified under CHIP-96 guidelines based on chemical content.
- US/Canadian regulation listings: SARA 313 - NO, TSCA - YES, Canada's Controlled Products - NO
- EC Relevant risk: None.
- EC Relevant safety: S: 37/39 - Wear suitable gloves and eye/face protection.
S:20 - When using do not eat or drink.
- Additional information: Consult country codes for specific requirements.

16. OTHER INFORMATION

- Further information contact: Your Swagelok Distributor or the contacts listed in Section 1 of this sheet.
- Sources of information used to compile document: Properties of individual ingredients were used to compile this document. This Material Safety Data Sheet was designed to give the distributors and users of PURE GOOP information to handle and use the product in a responsible manner.

Preparation Data		
Environmental and Safety Department	(440) 349-5955	November 2003



Revision Date: 12/10/2004

Issue date: 12/13/2004

1. CHEMICAL PRODUCT AND COMPANY IDENTIFICATION

Product name: Loctite(R) 222 Threadlocker Low Strength
Product Use: Sealant
Company address:
Henkel Canada, Inc.
2255 Meadowpine Boulevard
Mississauga, Ontario L5N 7P2

Item No. : 21464
Region: Canada
Contact Information:
Telephone: 905.814.6511
Emergency telephone: 905.814.6511
Internet: www.loctite.com

2. COMPOSITION/INFORMATION ON INGREDIENTS

<u>Hazardous components</u>	<u>%</u>	<u>ACGIH TLV</u>	<u>OSHA PEL</u>	<u>OTHER</u>
Polyglycol dimethacrylate 25852-47-5	30-60	None	None	None
Polyglycol oleate 9004-96-0	30-60	None	None	None
Silica, amorphous, treated 68909-20-6	5-10	10 mg/m ³ (Inhal)	20mppcf	6 mg/m ³
Saccharin 81-07-2	1-5	None	None	None
Propylene glycol 57-55-6	1-5	None	None	None
Cumene hydroperoxide 80-15-9	1-5	None	None	1 ppm (6 mg/m ³) Skin (WEEL)

3. HAZARDS IDENTIFICATION

EMERGENCY OVERVIEW

Physical state: Liquid
Color: Purple
Odor: Mild
WHMIS hazard class: D.2.B

WARNING: CAUSES EYE IRRITATION.
MAY CAUSE ALLERGIC SKIN REACTION.
MAY CAUSE SKIN IRRITATION.
MAY CAUSE RESPIRATORY TRACT IRRITATION.

Relevant routes of exposure: Skin, Inhalation, Eyes

Potential Health Effects

Inhalation: May cause respiratory tract irritation.
Skin contact: May cause allergic skin reaction. May cause skin irritation.
Eye contact: Contact with eyes will cause irritation.
Ingestion: Not expected to be harmful by ingestion.

Existing conditions aggravated by exposure: Eye, skin, and respiratory disorders.

See Section 11 for additional toxicological information.

Item No. : 21464

Product name: Loctite(R) 222 Threadlocker Low Strength

4. FIRST AID MEASURES

Inhalation:	Remove to fresh air. If symptoms develop and persist, get medical attention.
Skin contact:	Wash with soap and water. Remove contaminated clothing and shoes. Wash clothing before reuse. Get medical attention if symptoms occur.
Eye contact:	Flush with copious amounts of water, preferably, lukewarm water for at least 15 minutes, holding eyelids open all the time. Get medical attention.
Ingestion:	Do not induce vomiting. Keep individual calm. Obtain medical attention.

5. FIRE-FIGHTING MEASURES

Flash point:	Greater than 93°C (200°F) Tagliabue closed cup
Autoignition temperature:	Not available
Flammable/Explosive limits-lower %:	Not available
Flammable/Explosive limits-upper %:	Not available
Extinguishing media:	Foam, dry chemical or carbon dioxide.
Special fire fighting procedures:	Wear self-contained breathing apparatus and full protective clothing, such as turn-out gear.
Unusual fire or explosion hazards:	None
Hazardous combustion products:	Oxides of carbon. Oxides of sulfur. Oxides of nitrogen. Irritating organic vapors.
Sensitivity to mechanical impact:	Not available.
Sensitivity to static discharge:	Not available.

6. ACCIDENTAL RELEASE MEASURES

Environmental precautions:	Prevent product from entering drains or open waters.
Clean-up methods:	Soak up with inert absorbent. Store in a partly filled, closed container until disposal.

7. HANDLING AND STORAGE

Handling:	Avoid contact with eyes, skin and clothing. Avoid breathing vapor and mist. Wash thoroughly after handling. Use only with adequate ventilation.
Storage:	For safe storage, store at or below 38°C (100°F). Keep in a cool, well ventilated area away from heat, sparks and open flame. Keep container tightly closed until ready for use.
Incompatible products:	Refer to Section 10.

For information on product shelf life contact Loctite Canada Customer Service at (905) 814-6511.

8. EXPOSURE CONTROLS / PERSONAL PROTECTION

Engineering controls:	No specific ventilation requirements noted, but forced ventilation may still be required if concentrations exceed occupational exposure limits.
Respiratory protection:	Use NIOSH approved respirator if there is potential to exceed exposure limit(s).

Item No. : 21464

Product name: Loctite(R) 222 Threadlocker Low Strength

Skin protection: Use impermeable gloves and protective clothing as necessary to prevent skin contact. Neoprene gloves. Butyl rubber gloves. Natural rubber gloves.

Eye/face protection: Safety goggles or safety glasses with side shields.

See Section 2 for exposure limits.

9. PHYSICAL AND CHEMICAL PROPERTIES

Physical state: Liquid
Color: Purple
Odor: Mild
Odor Threshold: Not available
Vapor pressure: Less than 5 mm Hg at 27°C (80°F)
pH: Not applicable
Boiling point/range: Greater than 149°C (300°F)
Melting point/range: Not available
Specific gravity: 1.08 at 20°C (68°F)
Vapor density: Not available
Evaporation rate: Not available
Solubility in water: Slight
Partition coefficient (n-octanol/water): Not available
VOC content: 11.8%; 127 grams/liter (EPA Method 24)

10. STABILITY AND REACTIVITY

Stability: Stable.

Hazardous polymerization: Will not occur.

Hazardous decomposition products: Oxides of carbon. Oxides of sulfur. Oxides of nitrogen. Irritating organic vapors.

Incompatibility: Strong oxidizers.

Conditions to avoid: See "Handling and Storage" (Section 7) and "Incompatibility" (Section 10).

11. TOXICOLOGICAL INFORMATION

Product toxicity data: Acute oral LD50 greater than 10,000 mg/kg (rat). Acute dermal LD50 greater than 5000 mg/kg (rabbit).

Toxicologically synergistic products: Not available.

Refer to the following for Irritancy of Product, Sensitization to Product, Carcinogenicity, Reproductive Toxicity, Teratogenicity, and Mutagenicity.

Ingredient Toxicity Data & Carcinogen Status

Hazardous components	LD50s & LC50s (NIOSH) :	Other LD50s and LC50s:	NTP Carcinogen	IARC Carcinogen	OSHA Carcinogen	ACGIH - Carcinogens
Polyglycol dimethacrylate 25852-47-5	None	None	No	No	No	No
Polyglycol oleate 9004-96-0	Oral LD50 (Mouse) > 25 g/kg	None	No	No	No	No
Silica, amorphous, treated 68909-20-6	None	None	No	No	No	No
Saccharin 81-07-2	Oral LD50 (Mouse) = 17 g/kg	None	No	No	No	No

Item No. : 21464

3 of 5

Product name: Loctite(R) 222 Threadlocker Low Strength

Propylene glycol 57-55-6	Oral LD50 (Rat) = 20 g/kg Dermal LD50 (Rabbit) = 20800 mg/kg Oral LD50 (Mouse) = 22 g/kg	None	No	No	No	No
Cumene hydroperoxide 80-15-9	Inhalation LC50 (Mouse) = 200 ppm Inhalation LC50 (Rat) = 220 ppm Oral LD50 (Rat) = 382 mg/kg	None	No	No	No	No

Literature Referenced Target Organ & Other Health Effects

Hazardous components	Health Effects/Target Organs
Polyglycol dimethacrylate 25852-47-5	Allergen, Irritant
Polyglycol oleate 9004-96-0	Irritant
Silica, amorphous, treated 68909-20-6	No Target Organs
Saccharin 81-07-2	No Target Organs
Propylene glycol 57-55-6	Irritant
Cumene hydroperoxide 80-15-9	Allergen, Central nervous system, Corrosive, Irritant, Mutagen

12. ECOLOGICAL INFORMATION

Ecological information: Not available

13. DISPOSAL CONSIDERATIONS

Information provided is for unused product only.

Recommended method of disposal: Dispose of in accordance with federal and local regulations.

14. TRANSPORT INFORMATION

Canada Transportation of Dangerous Goods - Ground:

Proper shipping name: Unrestricted
Hazard class or division: None
Identification number: None
Packing group: None

International Air Transportation (ICAO/IATA):

Proper shipping name: Unrestricted
Hazard class or division: None
Identification number: None
Packing group: None

WaterTransportation (IMO/IMDG):

Proper shipping name: Unrestricted
Hazard class or division: None
Identification number: None
Packing group: None
Marine pollutant: None

Item No. : 21464

Product name: Loctite(R) 222 Threadlocker Low Strength

15. REGULATORY INFORMATION

Canada Regulatory Information

CEPA DSL/NDSL Status: All components are listed on or are exempt from listing on the Domestic Substances List.

United States Regulatory Information

TSCA 8 (b) Inventory Status: All components are listed or are exempt from listing on the Toxic Substances Control Act Inventory.

16. OTHER INFORMATION

This material safety data sheet contains changes from the previous version in sections: New Material Safety Data Sheet format.

This product has been classified in accordance with the hazard criteria of the Controlled Products Regulations and the MSDS contains all the information required by the Controlled Product Regulations.

Prepared by: Kyra Kozak Woods, Health and Regulatory Affairs Specialist

DISCLAIMER: The data contained herein are furnished for information only and are believed to be reliable. However, Henkel Corporation does not assume responsibility for any results obtained by persons over whose methods Henkel Corporation has no control. It is the user's responsibility to determine the suitability of Henkel's products or any production methods mentioned herein for a particular purpose, and to adopt such precautions as may be advisable for the protection of property and persons against any hazards that may be involved in the handling and use of any of Henkel Corporation's products. In light of the foregoing, Henkel Corporation specifically disclaims all warranties, express or implied, including warranties of merchantability and fitness for a particular purpose, arising from sale or use of Henkel Corporation's products. Henkel Corporation further disclaims any liability for consequential or incidental damages of any kind, including lost profits.

JL-M MATERIAL SAFETY DATA SHEET

SECTION 1 – PRODUCT IDENTIFICATION				
Product Name: JL-M Lubricant Revised: 03/07/03 Supercedes: 03/17/00 Prepared by: C. Semerod Emergency Information: (412) 279-1149	Manufacturer's Name: Superbolt, Inc. Manufacturer's Address: 1000 Gregg Street Carnegie, PA 15106 Manufacturer's Phone #: (412) 279-1149			
SECTION 2 – HAZARDOUS INGREDIENTS				
CHEMICAL NAME:	CAS NO.:	OSHA PEL:	ACGIH TLV:	(STEL)
Molybdenum Disulfide	1317-33-5	10 mg/m3	10 mg/m3	N/A
Silica, Fused	60676-86-0	0.1 mg/m3	0.1 mg/m3	N/A
Graphite	7782-42-5		2 mg/m3	N/A
Silica, Crystalline	14808-60-7		0.1 mg/m3	N/A
Lubricating Oils, Petroleum, Hydrotreated, Spent	64742-58-1	5 mg/m3*	5 mg/m3*	10mg/m3*
Residual Oils (Petroleum), Solvent Dewaxed	64742-62-7	5 mg/m3*	5 mg/m3*	10 mg/m3*
Solvent-Refined Heavy Paraffinic Distillate (Petroleum)	64741-88-4	5 mg/m3*	5 mg/m3*	10 mg/m3*
Solvent –Dewaxed Hydrotreated Heavy Paraffinic Distillate (Petroleum)	64742-65-0	5 mg/m3*	5 mg/m3*	10 mg/m3*
Hydrotreated Heavy Paraffinic Distillate (Petroleum)	64742-54-7	5 mg/m3*	5 mg/m3*	10 mg/m3*
Proprietary Additives Mixture (<1%)				
(*) Designates limits set by OSHA and the ACGIH for oil mist. This product is sold in a paste form so misting should not occur.				
SECTION 3 – PHYSICAL DATA		SECTION 4 – FIRE AND EXPLOSION DATA		
Appearance and Odor: Dark Grey Paste, Mild Petroleum Boiling Point: > 500 degrees F % Volatile: 0% Vapor Density: > 1 (Air = 1) Evaporation Rate: < 1 (Ether = 1) Specific Gravity: 4.8 (Water = 1) Vapor Pressure: Essentially 0 (mm Hg) Solubility in Water: Insoluble pH: N/A		Flash Point: 338 degrees F Lower Explosive Limit: N/A Upper Explosive Limit: N/A Extinguishing Media: Carbon Dioxide, Regular Foam, Dry Chemical Special Fire Fighting Procedures: Fire may produce dense smoke, firefighters should wear self contained breathing apparatus. Use water to cool fire exposed containers. Unusual Fire & Explosion Hazards: Decomposition and combustion by-products may be toxic. Heated containers may rupture or explode.		
SECTION 5 – REACTIVITY DATA		SECTION 6 – STORAGE & HANDLING		
Stability: Stable Hazardous Polymerization: Will not occur. Incompatibility: Avoid contact with oxidizing agents, heat, sparks or flame. Hazardous Combustion By-Products: Carbon Monoxide, Sulfur Dioxide, Aldehydes, and Nitrogen Oxides Hazardous Decomposition: Thermal decomposition may yield methacrylate monomers.		Handling Precautions: Use good personal hygiene practices. Clean contaminated clothing and protective equipment before reuse. Storage Precautions: Store in a cool dry location. Keep container tightly closed when not in use and during transport. Keep away from open sparks or flames.		
SECTION 7 – HEALTH HAZARDS				
Effects of Overexposure: Skin: May Cause Irritation Eyes: Eye Irritant. May cause redness and Blurred vision. Ingestion: Not Expected Inhalation: Not Expected (Chronic respiratory diseases may be aggravated by dust exposure.) NFPA CODES: Health: 1 Flammability: 1 Reactivity: 0 Carcinogenicity: Silica is a suspected carcinogen in a respirable form by the IARC and NTP however, not by the ACIGH or OSHA.		First Aid Procedures: Skin: Remove contaminated clothing from irritated area. Flush exposed area with mild soap and water. Seek medical attention if irritation persists. Eyes: Flush eyes with large quantities of water, holding eyelids open. Seek medical attention if irritation persists. Ingestion: Do not induce vomiting. If spontaneous vomiting occurs, keep head below hips to avoid aspiration into the lungs. Seek immediate medical attention. Inhalation: Remove to fresh air. Obtain medical attention if necessary.		
SECTION 8 – SPECIAL PROTECTION		SECTION 9 – SPILL AND DISPOSAL PROCEDURES		
Eye Protection: Safety Glasses or Face Shield Protective Gloves: Recommended Respiratory Protection: Avoid breathing dust, use an approved respirator if levels exceed OSHA limits. Ventilation: Local ventilation to maintain levels within OSHA limits.		Spill Procedures: Scrape or wipe up any spilled material. Wear proper protective equipment when cleaning up a spill. Disposal Procedures: Dispose of in accordance with any applicable federal, state, or local laws.		

The information in this MSDS was obtained from sources which we believe are reliable. However, the information is provided without any representation or warranty, expressed or implied, regarding the accuracy or correctness. The conditions or methods of handling, storage, use and disposal of the product are beyond our control. For this and other reasons, we do not assume responsibility and expressly disclaim liability for loss, damage, or expense arising out of or in any way connected with the handling, storage, use or disposal of the product.



LUBRIPLATE®

MATERIAL SAFETY DATA SHEET

Section 1

PRODUCT NAME OR NUMBER:

LUBRIPLATE Super FML-0, FML-1, FML-2

FORMULA:

Calcium Soap, USP Mineral Oil and Additives

GENERIC/CHEMICAL NAME:

Petroleum Lubricating Grease

NSF Registration No's:

125742, 125740, 125741

Manufacturer's Name:

Fiske Brothers Refining Co.

Emergency Telephone Number:

1-800-255-3924 - CHEM-TEL (24 hour)

Address:

1500 Oakdale Ave., Toledo, Ohio 43605 - 129 Lockwood St., Newark, NJ 07105

Telephone Number for Information:

419-691-2491 - Toledo Office

Section 2 - Hazardous Ingredients/Identity Information

<u>Hazardous Components</u>	<u>OSHA PEL</u>	<u>ACGIH TLV</u>	<u>Other Limits Recommended</u>	<u>% (optional)</u>
-----------------------------	-----------------	------------------	---------------------------------	---------------------

Non-hazardous

Hazardous Material Identification System (HMIS): Health - 1, Flammability - 1, Reactivity - 0**Not a Controlled Product under (WHMIS) - Canada****Special Protection: See Section 9**

Section 3 - Health Hazard Data

Threshold Limit Value: 5 mg/m³ for oil mist in air. OSHA Regulation 29 CFR 1910.1000**Effects of Overexposure:** Prolonged or repeated skin contact may cause skin irritation. Product contacting the eyes may cause eye irritation. Human health risks vary from person to person. As a precaution, exposure to liquids, vapors, mists and fumes should be minimized. This product has a low order of acute oral toxicity, but minute amounts aspirated into the lungs during ingestion may cause mild to severe pulmonary injury.**Carcinogenicity:** NTP? No IARC Monographs? No OSHA Regulated? No

Section 4 - Emergency and First Aid Procedures

EYE CONTACT: Flush with clear water for 15 minutes or until irritation subsides. If irritation persists, consult a physician.**SKIN CONTACT:** Remove any contaminated clothing and wash with soap and warm water. If injected by high pressure under skin, regardless of the appearance or its size, contact a physician IMMEDIATELY. Delay may cause loss of affected part of the body.**INHALATION:** Vapor pressure is very low and inhalation at room temperature is not a problem. If overcome by vapor from hot product, immediately remove from exposure and call a physician.**INGESTION:** If ingested, call a physician immediately. Do not induce vomiting.

Section 5 - Fire and Explosion Hazard Data

Flash Point (Method Used): COC - 435°F **Flammable Limits:** LEL 0.9% UEL 7.0%**Extinguishing Media:** Foam, Dry Chemical, Carbon Dioxide or Water Spray (Fog)**Special Fire Fighting Procedures:** Cool exposed containers with water. Use air-supplied breathing equipment for enclosed or confined spaces.**Unusual Fire and Explosion Hazards:** Do not store or mix with strong oxidants. Empty containers retain residue. Do not cut, drill, grind, or weld, as they may explode.

Section 6 - Physical/Chemical Characteristics

Boiling Point:	>550°F	Specific Gravity (H₂O = 1):	0.90 - 0.91
Vapor Pressure (mm Hg.):	<0.01	Melting Point:	Semi-solid
Vapor Density (AIR = 1):	>5	Evaporation Rate: (Butyl Acetate = 1)	<0.01
Solubility in Water:	Negligible		
Appearance and Odor:	Smooth, white grease with mineral oil odor.		

Section 7 - Reactivity Data

Stability:	Unstable Stable X	Conditions to Avoid:	N/A
Incompatibility (Materials to Avoid):	Avoid contact with strong oxidants like liquid chlorine, concentrated oxygen.		
Hazardous Decomposition or Byproducts:	May form SO ₂ . If incomplete combustion, Carbon Monoxide.		
Hazardous Polymerization:	May Occur Will Not Occur X	Conditions to Avoid:	N/A

Section 8 - Spill or Leak Procedures

Steps to be taken in case material is released or spilled:

Scrape up grease, wash remainder with suitable petroleum solvent or add absorbent. Keep petroleum products out of sewers and watercourses. Advise authorities if product has entered or may enter sewers and watercourses.

Waste disposal method:

Assure conformity with applicable disposal regulations. Dispose of absorbed material at an approved waste disposal facility or site.

SARA/TITLE III, Section 313 Status - Zinc Compounds - <6%

Section 9 - Special Protection Information

Respiratory Protection (Specify type):	Normally not needed		
Ventilation	Local Exhaust:	Used to capture fumes and vapors	Special: N/A
	Mechanical (General)		Other: N/A
Protective Gloves:	Use oil-resistant gloves, if needed.	Eye Protection:	If chance of eye contact, wear goggles.
Other Protective Equipment:	Use oil-resistant apron, if needed.		

Section 10 - Special Precautions

Precautions to be taken in handling and storing:

Keep containers closed when not in use. Do not handle or store near heat, sparks, flame, or strong oxidants.

Other Precautions:

Remove oil-soaked clothing and laundry before reuse. Cleanse skin thoroughly after contact.

The above information is furnished without warranty, expressed or implied, except that it is accurate to the best knowledge of Fiske Brothers Refining Company. The data on these sheets relates only to the specific material designated herein. Fiske Brothers Refining Company assumes no legal responsibility for use or reliance upon this data.

MATERIAL SAFETY DATA SHEET

SECTION 1 PRODUCT AND COMPANY IDENTIFICATION

PRODUCT

Product Name: MOBIL DTE 26
Product Description: Base Oil and Additives
Product Code: 201560102030, 602649-00, 970101
Intended Use: Hydraulic fluid

COMPANY IDENTIFICATION

Supplier: EXXON MOBIL CORPORATION
3225 GALLOWS RD.
FAIRFAX, VA. 22037 USA

24 Hour Health Emergency 609-737-4411
Transportation Emergency Phone 800-424-9300
ExxonMobil Transportation No. 281-834-3296
MSDS Requests 713-613-3661
Product Technical Information 800-662-4525, 800-947-9147
MSDS Internet Address <http://www.exxon.com>, <http://www.mobil.com>

SECTION 2 COMPOSITION / INFORMATION ON INGREDIENTS

No Reportable Hazardous Substance(s) or Complex Substance(s).

SECTION 3 HAZARDS IDENTIFICATION

This material is not considered to be hazardous according to regulatory guidelines (see (M)SDS Section 15).

POTENTIAL HEALTH EFFECTS

Low order of toxicity. Excessive exposure may result in eye, skin, or respiratory irritation. High-pressure injection under skin may cause serious damage.

NFPA Hazard ID:	Health: 0	Flammability: 1	Reactivity: 0
HMIS Hazard ID:	Health: 0	Flammability: 1	Reactivity: 0

NOTE: This material should not be used for any other purpose than the intended use in Section 1 without expert advice. Health studies have shown that chemical exposure may cause potential human health risks which may vary from person to person.

SECTION 4 FIRST AID MEASURES

INHALATION

Remove from further exposure. For those providing assistance, avoid exposure to yourself or others. Use adequate respiratory protection. If respiratory irritation, dizziness, nausea, or unconsciousness occurs, seek immediate medical assistance. If breathing has stopped, assist ventilation with a mechanical device or use

Product Name: MOBIL DTE 26

Revision Date: 14Apr2008

Page 2 of 8

mouth-to-mouth resuscitation.

SKIN CONTACT

Wash contact areas with soap and water. If product is injected into or under the skin, or into any part of the body, regardless of the appearance of the wound or its size, the individual should be evaluated immediately by a physician as a surgical emergency. Even though initial symptoms from high pressure injection may be minimal or absent, early surgical treatment within the first few hours may significantly reduce the ultimate extent of injury.

EYE CONTACT

Flush thoroughly with water. If irritation occurs, get medical assistance.

INGESTION

First aid is normally not required. Seek medical attention if discomfort occurs.

SECTION 5 FIRE FIGHTING MEASURES

EXTINGUISHING MEDIA

Appropriate Extinguishing Media: Use water fog, foam, dry chemical or carbon dioxide (CO₂) to extinguish flames.

Inappropriate Extinguishing Media: Straight Streams of Water

FIRE FIGHTING

Fire Fighting Instructions: Evacuate area. Prevent runoff from fire control or dilution from entering streams, sewers, or drinking water supply. Firefighters should use standard protective equipment and in enclosed spaces, self-contained breathing apparatus (SCBA). Use water spray to cool fire exposed surfaces and to protect personnel.

Unusual Fire Hazards: Pressurized mists may form a flammable mixture.

Hazardous Combustion Products: Aldehydes, Smoke, Fume, Sulfur oxides, Incomplete combustion products, Oxides of carbon

FLAMMABILITY PROPERTIES

Flash Point [Method]: >204C (399F) [ASTM D-92]

Flammable Limits (Approximate volume % in air): LEL: 0.9 UEL: 7.0

Autoignition Temperature: N/D

SECTION 6 ACCIDENTAL RELEASE MEASURES

NOTIFICATION PROCEDURES

In the event of a spill or accidental release, notify relevant authorities in accordance with all applicable regulations. In the event of a spill or accidental release, notify relevant authorities in accordance with all applicable regulations. US regulations require reporting releases of this material to the environment which exceed the applicable reportable quantity or oil spills which could reach any waterway including intermittent dry creeks. The National Response Center can be reached at (800)424-8802.

SPILL MANAGEMENT

Land Spill: Stop leak if you can do it without risk. Recover by pumping or with suitable absorbent.

Water Spill: Stop leak if you can do it without risk. Confine the spill immediately with booms. Warn other shipping. Remove from the surface by skimming or with suitable absorbents. Seek the advice of a specialist before using dispersants.

Water spill and land spill recommendations are based on the most likely spill scenario for this material; however, geographic conditions, wind, temperature, (and in the case of a water spill) wave and current direction and speed may greatly influence the appropriate action to be taken. For this reason, local experts should be consulted. Note: Local regulations may prescribe or limit action to be taken.

ENVIRONMENTAL PRECAUTIONS

Large Spills: Dike far ahead of liquid spill for later recovery and disposal. Prevent entry into waterways, sewers, basements or confined areas.

SECTION 7	HANDLING AND STORAGE
------------------	-----------------------------

HANDLING

Prevent small spills and leakage to avoid slip hazard.

Static Accumulator: This material is a static accumulator.

STORAGE

Do not store in open or unlabelled containers.

SECTION 8	EXPOSURE CONTROLS / PERSONAL PROTECTION
------------------	--

Exposure limits/standards for materials that can be formed when handling this product: When mists / aerosols can occur, the following are recommended: 5 mg/m³ - ACGIH TLV, 10 mg/m³ - ACGIH STEL, 5 mg/m³ - OSHA PEL.

NOTE: Limits/standards shown for guidance only. Follow applicable regulations.

ENGINEERING CONTROLS

The level of protection and types of controls necessary will vary depending upon potential exposure conditions. Control measures to consider:

No special requirements under ordinary conditions of use and with adequate ventilation.

PERSONAL PROTECTION

Personal protective equipment selections vary based on potential exposure conditions such as applications, handling practices, concentration and ventilation. Information on the selection of protective equipment for use with this material, as provided below, is based upon intended, normal usage.

Product Name: MOBIL DTE 26

Revision Date: 14Apr2008

Page 4 of 8

Respiratory Protection: If engineering controls do not maintain airborne contaminant concentrations at a level which is adequate to protect worker health, an approved respirator may be appropriate. Respirator selection, use, and maintenance must be in accordance with regulatory requirements, if applicable. Types of respirators to be considered for this material include:

No special requirements under ordinary conditions of use and with adequate ventilation.

For high airborne concentrations, use an approved supplied-air respirator, operated in positive pressure mode. Supplied air respirators with an escape bottle may be appropriate when oxygen levels are inadequate, gas/vapor warning properties are poor, or if air purifying filter capacity/rating may be exceeded.

Hand Protection: Any specific glove information provided is based on published literature and glove manufacturer data. Glove suitability and breakthrough time will differ depending on the specific use conditions. Contact the glove manufacturer for specific advice on glove selection and breakthrough times for your use conditions. Inspect and replace worn or damaged gloves. The types of gloves to be considered for this material include:

No protection is ordinarily required under normal conditions of use.

Eye Protection: If contact is likely, safety glasses with side shields are recommended.

Skin and Body Protection: Any specific clothing information provided is based on published literature or manufacturer data. The types of clothing to be considered for this material include:

No skin protection is ordinarily required under normal conditions of use. In accordance with good industrial hygiene practices, precautions should be taken to avoid skin contact.

Specific Hygiene Measures: Always observe good personal hygiene measures, such as washing after handling the material and before eating, drinking, and/or smoking. Routinely wash work clothing and protective equipment to remove contaminants. Discard contaminated clothing and footwear that cannot be cleaned. Practice good housekeeping.

ENVIRONMENTAL CONTROLS

See Sections 6, 7, 12, 13.

SECTION 9

PHYSICAL AND CHEMICAL PROPERTIES

Typical physical and chemical properties are given below. Consult the Supplier in Section 1 for additional data.

GENERAL INFORMATION

Physical State: Liquid

Color: Brown

Odor: Characteristic

Odor Threshold: N/D

IMPORTANT HEALTH, SAFETY, AND ENVIRONMENTAL INFORMATION

Relative Density (at 15 C): 0.881

Flash Point [Method]: >204C (399F) [ASTM D-92]

Flammable Limits (Approximate volume % in air): LEL: 0.9 UEL: 7.0

Autoignition Temperature: N/D

Boiling Point / Range: > 316C (600F)

Vapor Density (Air = 1): > 2 at 101 kPa

Product Name: MOBIL DTE 26

Revision Date: 14Apr2008

Page 5 of 8

Vapor Pressure: < 0.013 kPa (0.1 mm Hg) at 20 C

Evaporation Rate (n-butyl acetate = 1): N/D

pH: N/A

Log Pow (n-Octanol/Water Partition Coefficient): > 3.5

Solubility in Water: Negligible

Viscosity: 71.2 cSt (71.2 mm²/sec) at 40 C | 8.5 cSt (8.5 mm²/sec) at 100C

Oxidizing Properties: See Sections 3, 15, 16.

OTHER INFORMATION

Freezing Point: N/D

Melting Point: N/A

Pour Point: -18°C (0°F)

DMSO Extract (mineral oil only), IP-346: < 3 %wt

SECTION 10	STABILITY AND REACTIVITY
-------------------	---------------------------------

STABILITY: Material is stable under normal conditions.

CONDITIONS TO AVOID: Excessive heat. High energy sources of ignition.

MATERIALS TO AVOID: Strong oxidizers

HAZARDOUS DECOMPOSITION PRODUCTS: Material does not decompose at ambient temperatures.

HAZARDOUS POLYMERIZATION: Will not occur.

SECTION 11	TOXICOLOGICAL INFORMATION
-------------------	----------------------------------

ACUTE TOXICITY

Route of Exposure	Conclusion / Remarks
Inhalation	
Toxicity (Rat): LC50 > 5000 mg/m ³	Minimally Toxic. Based on assessment of the components.
Irritation: No end point data.	Negligible hazard at ambient/normal handling temperatures. Based on assessment of the components.
Ingestion	
Toxicity (Rat): LD50 > 2000 mg/kg	Minimally Toxic. Based on test data for structurally similar materials.
Skin	
Toxicity (Rabbit): LD50 > 2000 mg/kg	Minimally Toxic. Based on test data for structurally similar materials.
Irritation (Rabbit): Data available.	Negligible irritation to skin at ambient temperatures. Based on assessment of the components.
Eye	
Irritation (Rabbit): Data available.	May cause mild, short-lasting discomfort to eyes. Based on assessment of the components.

CHRONIC/OTHER EFFECTS

Contains:

Base oil severely refined: Not carcinogenic in animal studies. Representative material passes IP-346, Modified Ames test, and/or other screening tests. Dermal and inhalation studies showed minimal effects; lung non-

Product Name: MOBIL DTE 26

Revision Date: 14Apr2008

Page 6 of 8

specific infiltration of immune cells, oil deposition and minimal granuloma formation. Not sensitizing in test animals.

Additional information is available by request.

The following ingredients are cited on the lists below: None.

--REGULATORY LISTS SEARCHED--

1 = NTP CARC

3 = IARC 1

5 = IARC 2B

2 = NTP SUS

4 = IARC 2A

6 = OSHA CARC

SECTION 12

ECOLOGICAL INFORMATION

The information given is based on data available for the material, the components of the material, and similar materials.

ECOTOXICITY

Material -- Not expected to be harmful to aquatic organisms.

MOBILITY

Base oil component -- Low solubility and floats and is expected to migrate from water to the land. Expected to partition to sediment and wastewater solids.

PERSISTENCE AND DEGRADABILITY

Biodegradation:

Base oil component -- Expected to be inherently biodegradable

BIOACCUMULATION POTENTIAL

Base oil component -- Has the potential to bioaccumulate, however metabolism or physical properties may reduce the bioconcentration or limit bioavailability.

SECTION 13

DISPOSAL CONSIDERATIONS

Disposal recommendations based on material as supplied. Disposal must be in accordance with current applicable laws and regulations, and material characteristics at time of disposal.

DISPOSAL RECOMMENDATIONS

Product is suitable for burning in an enclosed controlled burner for fuel value or disposal by supervised incineration at very high temperatures to prevent formation of undesirable combustion products.

REGULATORY DISPOSAL INFORMATION

RCRA Information: The unused product, in our opinion, is not specifically listed by the EPA as a hazardous waste (40 CFR, Part 261D), nor is it formulated to contain materials which are listed as hazardous wastes. It does not exhibit the hazardous characteristics of ignitability, corrosivity or reactivity and is not formulated with contaminants as determined by the Toxicity Characteristic Leaching Procedure (TCLP). However, used product may be regulated.

Product Name: MOBIL DTE 26
 Revision Date: 14Apr2008
 Page 7 of 8

Empty Container Warning Empty Container Warning (where applicable): Empty containers may contain residue and can be dangerous. Do not attempt to refill or clean containers without proper instructions. Empty drums should be completely drained and safely stored until appropriately reconditioned or disposed. Empty containers should be taken for recycling, recovery, or disposal through suitably qualified or licensed contractor and in accordance with governmental regulations. DO NOT PRESSURISE, CUT, WELD, BRAZE, SOLDER, DRILL, GRIND, OR EXPOSE SUCH CONTAINERS TO HEAT, FLAME, SPARKS, STATIC ELECTRICITY, OR OTHER SOURCES OF IGNITION. THEY MAY EXPLODE AND CAUSE INJURY OR DEATH.

SECTION 14	TRANSPORT INFORMATION
-------------------	------------------------------

LAND (DOT) : Not Regulated for Land Transport

LAND (TDG) : Not Regulated for Land Transport

SEA (IMDG) : Not Regulated for Sea Transport according to IMDG-Code

AIR (IATA) : Not Regulated for Air Transport

SECTION 15	REGULATORY INFORMATION
-------------------	-------------------------------

OSHA HAZARD COMMUNICATION STANDARD: When used for its intended purposes, this material is not classified as hazardous in accordance with OSHA 29 CFR 1910.1200.

NATIONAL CHEMICAL INVENTORY LISTING: PICCS, TSCA, EINECS, IECSC, AICS, ENCS, KECI, DSL

EPCRA: This material contains no extremely hazardous substances.

SARA (311/312) REPORTABLE HAZARD CATEGORIES: None.

SARA (313) TOXIC RELEASE INVENTORY: This material contains no chemicals subject to the supplier notification requirements of the SARA 313 Toxic Release Program.

The Following Ingredients are Cited on the Lists Below:

Chemical Name	CAS Number	List Citations
ZINC ALKYL DITHIOPHOSPHATE	68649-42-3	15

--REGULATORY LISTS SEARCHED--

- | | | | |
|---------------|------------------|-------------------|-------------|
| 1 = ACGIH ALL | 6 = TSCA 5a2 | 11 = CA P65 REPRO | 16 = MN RTK |
| 2 = ACGIH A1 | 7 = TSCA 5e | 12 = CA RTK | 17 = NJ RTK |
| 3 = ACGIH A2 | 8 = TSCA 6 | 13 = IL RTK | 18 = PA RTK |
| 4 = OSHA Z | 9 = TSCA 12b | 14 = LA RTK | 19 = RI RTK |
| 5 = TSCA 4 | 10 = CA P65 CARC | 15 = MI 293 | |

Code key: CARC=Carcinogen; REPRO=Reproductive

SECTION 16	OTHER INFORMATION
-------------------	--------------------------

Product Name: MOBIL DTE 26

Revision Date: 14Apr2008

Page 8 of 8

N/D = Not determined, N/A = Not applicable

THIS SAFETY DATA SHEET CONTAINS THE FOLLOWING REVISIONS:

Revision Changes:

Section 06: Notification Procedures - Header was modified.

Section 13: Empty Container Warning was modified.

Section 08: Hand Protection was modified.

Section 15: List Citation Table - Header was modified.

Section 15: National Chemical Inventory Listing was modified.

Section 06: Notification Procedures was modified.

Section 15: TSCA Class 2 Statement was deleted.

The information and recommendations contained herein are, to the best of ExxonMobil's knowledge and belief, accurate and reliable as of the date issued. You can contact ExxonMobil to insure that this document is the most current available from ExxonMobil. The information and recommendations are offered for the user's consideration and examination. It is the user's responsibility to satisfy itself that the product is suitable for the intended use. If buyer repackages this product, it is the user's responsibility to insure proper health, safety and other necessary information is included with and/or on the container. Appropriate warnings and safe-handling procedures should be provided to handlers and users. Alteration of this document is strictly prohibited. Except to the extent required by law, republication or retransmission of this document, in whole or in part, is not permitted. The term, "ExxonMobil" is used for convenience, and may include any one or more of ExxonMobil Chemical Company, Exxon Mobil Corporation, or any affiliates in which they directly or indirectly hold any interest.

Internal Use Only

MHC: 0, 0, 0, 0, 0, 0

PPEC: A

DGN: 2007812XUS (546747)

Copyright 2002 Exxon Mobil Corporation, All rights reserved

Material Safety Data Sheet



HYDROCLEAR MULTIPURPOSE R&O OIL 32, 46, 68, 100, 150, 220, 320, 460

1. CHEMICAL PRODUCT/COMPANY IDENTIFICATION

HYDROCLEAR(R) MULTIPURPOSE R&O OIL

MSDS Code: HYDC0009 Revised: 29-July-2002

"HYDROCLEAR" is a registered trademark of Conoco.

ISO Grades: 32, 46, 68 100, 150, 220, 320, 460

Product Use: Industrial Oil

MANUFACTURER/DISTRIBUTOR

Conoco Inc.
PO Box 2197
Houston, TX 77252

PHONE NUMBERS

Product Information: 1-281-293-5550

Transport Emergency: CHEMTREC 1-800-424-9300 or
1-703-527-3887 (call collect)

Medical Emergency: 1-800-342-5119 or 1-281-293-5119

WEB SITE: www.conoco.com

2. COMPOSITION/INFORMATION ON INGREDIENTS

COMPONENTS	CAS NUMBER	%
Highly refined base oils	64742-54-7	0-99.5
Proprietary additives	64742-01-4	0-99.5
		<5

If oil mist is generated, exposure limits apply. See Section 8.

3. HAZARDS IDENTIFICATION

--- EMERGENCY OVERVIEW ---

APPEARANCE / ODOR

Clear and bright liquid / mild petroleum hydrocarbon odor.

OSHA REGULATORY STATUS

This material is classified as non-hazardous under OSHA Regulations.

HMIS RATING Health: 1; Flammability: 1; Physical Hazard: 0.

NFPA RATING Health: 1; Flammability: 1; Instability: 0.

Potential Health Effects

Primary Route of Entry: Skin

The product, as with many petroleum products, may cause minor skin,
 eye, and lung irritation, but good hygienic practices can minimize
 these effects.

Normal use of this product does not result in generation of an oil
 mist. However if an oil mist is generated, overexposure can cause
 minor and reversible irritation to the eyes, skin, and especially
 the lungs. Proper personal protective equipment and sufficient
 ventilation can provide adequate protection.

Carcinogenicity Information

None of the components present in this material at concentrations
 equal to or greater than 0.1% are listed by IARC, NTP, OSHA or ACGIH
 as a carcinogen.

4. FIRST AID MEASURES

Inhalation

If inhaled, remove to fresh air. If not breathing, give artificial
 respiration. If breathing is difficult, give oxygen. Call a
 physician.

Skin Contact

Wash skin thoroughly with soap and water. If irritation develops
 and persists, consult a physician.

If injected under the skin, necrosis could occur. See physician.

Eye Contact

In case of contact, immediately flush eyes with plenty of water for
 at least 15 minutes. Call a physician.

Ingestion

Material poses an aspiration hazard. If swallowed, do not induce
 vomiting. Immediately give 2 glasses of water. Never give anything
 by mouth to an unconscious person. Call a physician.

If vomiting occurs naturally, have victim lean forward to reduce the
 risk of aspiration.

Notes to Physicians

Activated charcoal mixture may be administered. To prepare activated
 charcoal mixture, suspend 50 grams activated charcoal in 400 mL water
 and mix thoroughly. Administer 5 mL/kg, or 350 mL for an average
 adult.

High velocity injection under the skin can cause a bloodless puncture
 wound and result in necrosis. Immediate attention by a surgical
 specialist is recommended.

5. FIRE FIGHTING MEASURES

Flammable Properties

Flash Point (minimum): 365 F (185 C) (Grade 32)
 374 F (190 C) (Grade 46)
 410 F (210 C) (Grade 68)
 428 F (220 C) (Grade 100)
 440 F (227 C) (Grade 150)

460 F (238 C) (Grade 220)
 490 F (254 C) (Grade 320)
 509 F (265 C) (Grade 460)

 Flash Point (typical): 450 F (232 C) (Grade 32)
 460 F (238 C) (Grade 46)
 470 F (243 C) (Grade 68)
 515 F (268 C) (Grade 100)
 530 F (277 C) (Grade 150)
 545 F (285 C) (Grade 220)
 580 F (304 C) (Grade 320)
 585 F (307 C) (Grade 460)

 Method: COC
 Autoignition: Not Available
 Flammable limits in Air, % by Volume
 LEL: Undetermined
 UEL: Undetermined

 Extinguishing Media
 Water Spray, Foam, Dry Chemical, CO2.

 Fire Fighting Instructions
 Water or foam may cause frothing. Use water to keep fire-exposed
 containers cool. Water may be used to flush spills away from
 exposures.

 Products of combustion may contain carbon monoxide, carbon dioxide,
 and other toxic materials. Do not enter enclosed or confined space
 without proper protective equipment including respiratory protection.

6. ACCIDENTAL RELEASE MEASURES

 Safeguards (Personnel)
 NOTE: Review FIRE FIGHTING MEASURES and HANDLING (PERSONNEL) sections
 before proceeding with clean-up. Use appropriate PERSONAL PROTECTIVE
 EQUIPMENT during clean-up.

 Remove source of heat, sparks, and flame.

 Initial Containment
 Dike spill. Prevent material from entering sewers, waterways, or
 low areas.

 Spill Clean Up
 Recover free liquid for reuse or reclamation. Soak up with sawdust,
 sand, oil dry or other absorbent material.

7. HANDLING AND STORAGE

 Handling (Personnel)
 Avoid breathing vapors or mist. Avoid contact with eyes. Avoid
 prolonged or repeated contact with skin. Wash thoroughly after
 handling. Wash contaminated clothing prior to reuse.

 Handling (Physical Aspects)
 Close container after each use. Do not pressurize, cut, weld, braze,
 solder, grind, or drill on or near full or empty container. Empty
 container retains residue (liquid and/or vapor) and may explode in

- heat of a fire.
-
- Storage
- Store in accordance with National Fire Protection Association
- recommendations. Store in a cool, dry, well-ventilated place. Store
- away from oxidizers, heat, sparks and flames.

#8. EXPOSURE CONTROLS/PERSONAL PROTECTION

- Engineering Controls
- VENTILATION
- Normal shop ventilation.
-
- Personal Protective Equipment
-
- RESPIRATORY PROTECTION
- None normally required except in emergencies or when conditions
- cause excessive airborne levels of mists or vapors. Select
- appropriate NIOSH-approved respiratory protective equipment when
- exposed to sprays or mists. Proper respirator selection should be
- determined by adequately trained personnel and based on the
- contaminant(s), the degree of potential exposure, and published
- respirator protection factors.
-
- PROTECTIVE GLOVES
- Should be worn when the potential exists for prolonged or repeated
- skin contact. NBR or neoprene recommended.
-
- EYE PROTECTION
- Safety glasses with side shields.
-
- OTHER PROTECTIVE EQUIPMENT
- Coveralls with long sleeves if splashing is probable.

-
-
- Applicable Exposure Limits
- If oil mist is generated, exposure limits apply.
- PEL (OSHA): 5 mg/m3, 8 Hr. TWA
- TLV (ACGIH): 5 mg/m3, 8 Hr. TWA, STEL 10 mg/m3

9. PHYSICAL AND CHEMICAL PROPERTIES

- Physical Data
- Appearance: Clear and bright
- Odor: Mild petroleum hydrocarbon
- Boiling Point: Not Available
- Vapor Pressure: Nil
- Vapor Density: >1 (Air=1.0)
- % Volatiles: Nil
- Evaporation Rate: Nil
- Solubility in Water: Insoluble
- Specific Gravity: 0.85-0.90 @ 60 F (16 C)
- Pounds Per Gallon: 7.1-7.5 @ 60 F (16 C)
-
-
- Viscosity (typical): cSt @ 40 C cSt @ 100 C
- ISO 32 32.5 5.4
- ISO 46 45 6.7
- ISO 68 68.2 8.77
- ISO 100 101.1 11.3
- ISO 150 149 14.6

<input type="checkbox"/>	ISO 320	318	23.9	<input type="checkbox"/>
<input type="checkbox"/>	ISO 460	464	30.6	<input type="checkbox"/>

<input type="checkbox"/>	10. STABILITY AND REACTIVITY			<input type="checkbox"/>

<input type="checkbox"/>	Chemical Stability			<input type="checkbox"/>
<input type="checkbox"/>	Stable at normal temperatures and storage conditions.			<input type="checkbox"/>
<input type="checkbox"/>	Conditions to Avoid			<input type="checkbox"/>
<input type="checkbox"/>	Heat, sparks, and flames.			<input type="checkbox"/>
<input type="checkbox"/>	Incompatibility with Other Materials			<input type="checkbox"/>
<input type="checkbox"/>	Incompatible or can react with strong oxidizers.			<input type="checkbox"/>
<input type="checkbox"/>	Decomposition			<input type="checkbox"/>
<input type="checkbox"/>	Normal combustion forms carbon dioxide; incomplete combustion may produce carbon monoxide.			<input type="checkbox"/>
<input type="checkbox"/>	Polymerization			<input type="checkbox"/>
<input type="checkbox"/>	Polymerization will not occur.			<input type="checkbox"/>

<input type="checkbox"/>	11. TOXICOLOGICAL INFORMATION			<input type="checkbox"/>

<input type="checkbox"/>	Animal Data			<input type="checkbox"/>
<input type="checkbox"/>	Mouse skin painting studies have shown that highly refined petroleum lube base oils similar to ingredients in this product have not caused skin tumors. <input type="checkbox"/>			<input type="checkbox"/>

<input type="checkbox"/>	12. ECOLOGICAL INFORMATION			<input type="checkbox"/>

<input type="checkbox"/>	Ecotoxicological Information			<input type="checkbox"/>
<input type="checkbox"/>	No specific aquatic data available for this product.			<input type="checkbox"/>

<input type="checkbox"/>	13. DISPOSAL CONSIDERATIONS			<input type="checkbox"/>

<input type="checkbox"/>	Waste Disposal			<input type="checkbox"/>
<input type="checkbox"/>	Treatment, storage, transportation, and disposal must be in accordance with applicable Federal, State/Provincial, and Local regulations. Do not flush to surface water or sanitary sewer system. <input type="checkbox"/>			<input type="checkbox"/>
<input type="checkbox"/>	Container Disposal <input type="checkbox"/>			<input type="checkbox"/>
<input type="checkbox"/>	Empty drums should be completely drained, properly bunged, and promptly shipped to the supplier or a drum reconditioner. All other containers should be disposed of in an environmentally safe manner. <input type="checkbox"/>			<input type="checkbox"/>

<input type="checkbox"/>	14. TRANSPORTATION INFORMATION			<input type="checkbox"/>

<input type="checkbox"/>	Shipping Information			<input type="checkbox"/>
<input type="checkbox"/>	DOT:	Not regulated. <input type="checkbox"/>		<input type="checkbox"/>
<input type="checkbox"/>	IATA/IMDG:	Not restricted. <input type="checkbox"/>		<input type="checkbox"/>
<input type="checkbox"/>	Canada:	Not regulated. <input type="checkbox"/>		<input type="checkbox"/>

<input type="checkbox"/>	15. REGULATORY INFORMATION			<input type="checkbox"/>

<input type="checkbox"/>	U.S. Federal Regulations			<input type="checkbox"/>
<input type="checkbox"/>	OSHA HAZARD DETERMINATION <input type="checkbox"/>			<input type="checkbox"/>
<input type="checkbox"/>	This material is not known to be hazardous as defined by OSHA's Hazard Communication Standard, 29 CFR 1910.1200. <input type="checkbox"/>			<input type="checkbox"/>

CERCLA/SUPERFUND

Not applicable; this material is covered by the CERCLA petroleum

exclusion.

SARA, TITLE III, 302/304

Extremely Hazardous Substance: None

SARA, TITLE III, 311/312 HAZARD CLASSIFICATIONS

Acute: No

Chronic: No

Fire: No

Reactivity: No

Pressure: No

SARA, TITLE III, 313

Toxic Chemical: None

TSCA

Material and/or components are listed in the TSCA Inventory of

Chemical Substances (40 CFR 710).

RCRA

This material has been evaluated for RCRA characteristics and does

not meet hazardous waste criteria if discarded in its purchased

form. Because of product use, transformation, mixing, processing,

etc., which may render the resulting material hazardous, it is the

product user's responsibility to determine at the time of disposal

whether the material meets RCRA hazardous waste criteria.

CLEAN WATER ACT

The material contains the following ingredient(s) which is considered

hazardous if spilled into navigable waters and therefore reportable

to the National Response Center (1-800-424-8802).

Ingredient: Petroleum Hydrocarbons.

Reportable Quantity: Film or sheen upon or discoloration of

any water surface.

State Regulations (U.S.)

CALIFORNIA "PROP 65"

Ingredients subject to the Act: None.

PENNSYLVANIA WORKER & COMMUNITY RIGHT TO KNOW ACT

Ingredients subject to the Act: None.

Canadian Regulations

This is not a WHMIS Controlled Product.

16. OTHER INFORMATION

NOTE: This product or any other hydrocarbon-based lubricant should not be

used in non-diaphragm compressors that produce "breathing air"

unless the outlet is monitored continuously for carbon monoxide.

These lubricants can produce carbon monoxide when subjected to high

temperatures.

The data in this Material Safety Data Sheet relates only to the

specific material designated herein and does not relate to use in

combination with any other material or in any process.

☐				☐
☐	Responsibility for MSDS:	DNA - SHE	☐	
☐	Address:	Conoco Inc.		☐
☐		PO Box 2197		☐
☐		Houston, TX 77252		☐
☐	Telephone:	1-281-293-5550		☐
☐	Web Site:	www.conoco.com☐		
☐			☐	
☐	# Indicates updated section.			☐
☐		End of MSDS		☐
☐☐				
☐☐				



SECTION 1 - PRODUCT AND COMPANY IDENTIFICATION

PRODUCT IDENTIFICATION: . . : GERALYN AW 68

MANUFACTURER IDENTIFICATION

Company Name : FUCHS LUBRICANTS CO.
 Address : 17050 LATHROP AVE.
 HARVEY IL 60426
 Telephone : 708-333-8900
 Emergency Contact : Regulatory Compliance Department
 Emergency Telephone . . . : 708-333-8900 (8am - 5pm CST, M-F)
 800-255-3924 (24 Hours)

MSDS PRINT DATE : 07/26/2007

* EMERGENCY OVERVIEW

This product is a liquid that is insoluble in water.
 Direct eye contact may cause minor, short term irritation. Short term skin exposure is not expected to be irritating. Inhalation and ingestion are not anticipated routes of exposure during normal conditions of use.

* HMIS Rating: Health- 1 Flammability- 1 Reactivity- 0 PPE- X

SECTION 2 - COMPONENT DATA

Components listed in this section may contribute to the potential hazards associated with exposure to the concentrate. The product may contain additional non-hazardous or trade-secret components.

Mineral Oil	Cas#: proprietary	Percent: > 90
Exposure Limit:		
ACGIH TLV:	5 mg/m3 (as mist)	
ACGIH STEL:	10 mg/m3 (as mist)	
OSHA PEL:	5 mg/m3 (as mist)	

- Carcinogenic Components: This product contains no carcinogens.

SECTION 3 - HAZARDS IDENTIFICATION

POTENTIAL HEALTH EFFECTS and SYMPTOMS from SHORT TERM/ACUTE EXPOSURE:

- EYE EXPOSURE -
 This product is not expected to cause eye irritation under normal conditions of use. Symptoms of slight eye irritation may result when direct contact occurs, or when exposed to high mist levels in poorly ventilated areas.
- SKIN EXPOSURE -
 Short term skin contact is not expected to cause skin irritation. Prolonged or repeated direct exposure to the skin may result in



PRODUCT NAME: GERALYN AW 68

symptoms of irritation and redness. In severe cases, prolonged or repeated contact may result in dermatitis accompanied by symptoms of irritation, itching, dryness, cracking and/or inflammation.

- INHALATION -

This product has low volatility and so is not expected to cause respiratory tract irritation during normal conditions of use. Exposure to high mist levels in poorly ventilated areas may cause upper respiratory tract irritation and difficulty breathing.

- INGESTION -

Ingestion may cause slight stomach irritation and discomfort.

POTENTIAL CHRONIC HEALTH EFFECTS:

No further data known.

MEDICAL CONDITIONS AGGRAVATED BY EXPOSURE:

No further data known.

CARCINOGENICITY:

This product is not listed as a known or suspected carcinogen by IARC, OSHA, or the NTP.

SECTION 4 - FIRST AID MEASURES

EYE CONTACT:

Upon direct eye contact, hold eyelids open and flush with a steady, gentle stream of water for at least 15 minutes. If irritation is due to exposure to mist or vapors, remove the individual to fresh air. If irritation persists, flush the eyes with clean water until the irritation subsides. If symptoms persist, contact a physician.

SKIN CONTACT:

Remove product from the skin by washing with a mild soap and water. Contaminated clothing should be removed to prevent prolonged exposure. If symptoms of exposure persist, contact a physician.

INHALATION:

Inhalation is not an expected route of exposure. If respiratory irritation or distress occurs, remove the employee to fresh air. Contact a physician or other medical professional if irritation or distress persists.

INGESTION:

If small amounts are ingested, first aid measures are not likely to be necessary. If larger amounts are ingested or if symptoms of ingestion occur, dilute stomach contents with two glasses of water or milk. (NOTE: Do NOT give anything by mouth to an unconscious person.) Do not induce



PRODUCT NAME: GERALYN AW 68

vomiting without medical supervision. If vomiting occurs spontaneously keep airway clear. If symptoms of ingestion persist, seek medical attention.

NOTE TO PHYSICIAN:
No further data known.

SECTION 5 - FIRE FIGHTING MEASURES

FIRE AND EXPLOSIVE PROPERTIES:

Flashpoint	:	445.0	CF	COC
Flammability Limits	:	LEL		-N/A
		UEL		-N/A

EXTINGUISHING MEDIA:

In accordance with NFPA guidance, dry chemical, foam, or CO2 fire extinguishers are all acceptable. Note that while water fog extinguishers are also acceptable, do NOT apply a direct stream of water onto burning product because it may cause spreading and increase fire intensity.

UNUSUAL FIRE & EXPLOSION HAZARDS:

No further data known.

FIRE-FIGHTING PROCEDURES AND EQUIPMENT:

Emergency responders in the danger area should wear bunker gear and self-contained breathing apparatus for fires beyond the incipient stage. See Section 8 of the MSDS for other PPE to be worn as conditions warrant.

SECTION 6 - ACCIDENTAL RELEASE MEASURES

CLEAN-UP MEASURES:

Important: As with any spill or leak, before responding ensure that you are familiar with the potential hazards and recommendations of the MSDS. Appropriate personal protective equipment must be worn. See Section 8 of this MSDS for PPE recommendations.

If possible, safely contain the spill with dikes or other spill response equipment appropriate for petroleum or organic material releases. Take measures to prevent spreading of product. Note that while product will ignite it will not readily burn. However, as a precaution eliminate ignition sources. Prevent from entering sewers or waterways. Large volumes may be transferred to an appropriate container for proper disposal. Small volumes or residues may be soaked up with absorbents. Spill response materials should be collected for proper disposal.

SECTION 7 - HANDLING AND STORAGE

HANDLING:



PRODUCT NAME: GERALYN AW 68

As with any industrial chemical, handle the product in a manner that minimizes exposure to practicable levels. Prior to handling, consult Section 8 of this MSDS to evaluate personal protective equipment needs. Open containers slowly to relieve any pressure. Follow all other standard industrial hygiene practices.

Empty containers may contain product residue. All safety precautions taken when handling this product should also be taken when handling empty drums and containers. Keep containers closed when not in use.

Product residue in empty containers is combustible but will not readily burn. NOTE however, that excessive heating or cutting of empty containers may create an ignition source sufficient to start a fire and in extreme cases, cause an explosion.

STORAGE:

Protect product quality by storing indoors and away from extreme temperatures. Close all containers when not in use.

SPECIAL COMMENTS:

No further data known.

SECTION 8 - EXPOSURE CONTROLS, PERSONAL PROTECTION

PERSONAL PROTECTIVE EQUIPMENT:

Selection of personal protective equipment should be based upon the anticipated exposure and made in accordance with OSHA's Personal Protective Equipment Standard found in 29 CFR 1910 Subpart I. The following information may be used to assist in PPE selection.

- EYE PROTECTION -

Wear eye protection appropriate to prevent eye exposure. Where splashing is not likely, chemical safety glasses with side shields are recommended. Where splashing may occur, chemical goggles or full face shield is recommended.

- SKIN PROTECTION -

Gloves are not normally needed during normal conditions of use. If health effects are experienced, oil or chemical resistant gloves such as butyl or nitrile are recommended.

Where splashing or soaking is likely, wear oil or chemical resistant clothing to prevent exposure.

- RESPIRATORY PROTECTION -

A respirator may be worn to reduce exposure to vapors, dust, or mist. Select a NIOSH/MSHA approved respirator appropriate for the type and physical character of the airborne material. A self-contained breathing



PRODUCT NAME: GERALYN AW 68

apparatus is recommended in all situations where airborne contaminant concentration has not been confirmed to be below safe levels. Respirator use should comply with the OSHA Respirator Protection Standard found in 29 CFR 1910.134.

ENGINEERING CONTROLS:

Normal general ventilation is expected to be adequate. It is recommended that ventilation be designed in all instances to maintain airborne concentrations at lowest practicable levels. Ventilation should at a minimum, prevent airborne concentrations from exceeding any exposure limits listed in Section 2 of this MSDS.

The user may wish to refer to 29 CFR 1910.1000(d)(2) and the ACGIH "Threshold Limit Values for Chemical Substances and Physical Agents Biological Exposure Indices" (Appendix C) for the determination of exposure limits of mixtures. An industrial hygienist or similar professional may be consulted to confirm that the calculated exposure limits apply.

SECTION 9 - PHYSICAL AND CHEMICAL PROPERTIES

Physical Appearance	: Water white
Odor	: Mild petroleum
Physical State	: Liquid
Water Solubility	: Insoluble
Specific Gravity	: .868

SECTION 10 - STABILITY AND REACTIVITY

INCOMPATIBILITIES:

This product is incompatible with strong oxidizing agents.

DECOMPOSITION PRODUCTS MAY INCLUDE:

Thermal decomposition products are dependent on combustion conditions. A complex mixture of airborne solid, liquid, particulates and gasses may evolve when the material burns. Combustion byproducts may include:
oxides of carbon,
incompletely burned hydrocarbons as fumes and smoke.

CONDITIONS TO AVOID:

Avoid contact with incompatible materials and exposure to extreme temperatures.

POLYMERIZATION:

This product is not expected to polymerize.

STABILITY:



PRODUCT NAME: GERALYN AW 68

This product is stable.

SECTION 11 - TOXICOLOGICAL INFORMATION

EYE EFFECTS:

No further toxicological data known.

SKIN EFFECTS:

No further toxicological data known.

ORAL EFFECTS:

No further toxicological data known.

INHALATION EFFECTS:

No further toxicological data known.

OTHER:

No further data known.

SECTION 12 - ECOLOGICAL INFORMATION

ECOTOXICOLOGICAL INFORMATION:

This product has not been evaluated for ecotoxicity. As with any industrial chemical, exposure to the environment should be prevented and minimized wherever possible.

ENVIRONMENTAL FATE:

The degree of biodegradability and persistence of this product has not been determined.

SECTION 13 - DISPOSAL CONSIDERATIONS

WASTE DISPOSAL:

Ensure that collection, transport, treatment, and disposal of waste product, containers and rinsate complies with all applicable laws and regulations. Note that use, mixture, processing, or contamination of the product may cause the material to be classified as a hazardous waste. It is the responsibility of the product user or owner to determine at the time of disposal, whether the product is regulated as a hazardous waste.

SECTION 14 - TRANSPORT INFORMATION

DOT HAZARDOUS MATERIAL INFORMATION:

* Not otherwise DOT regulated.

SECTION 15 - REGULATORY INFORMATION

FEDERAL REGULATIONS:



PRODUCT NAME: GERALYN AW 68

SARA 313:

This product contains NONE of the substances subject to the reporting requirements of Section 313 of Title III of the Superfund Amendments and Reauthorization Act of 1986 and 40 CFR Part 372.

Clean Water Act / Oil Pollution Act:

This product contains mineral oil and is subject to regulation by Section 311 of the Clean Water Act and the Oil Pollution Act. Releases of the product into or leading to surface waters must be reported to the National Response Center at 1-800-424-8802.

CERCLA Reportable Quantity:

Any components listed below have been assigned a reportable quantity (RQ) by the Federal EPA. Releases of the product into the environment that exceed the RQ for a particular component must be reported to the National Response Center at 1-800-424-8802.

Component	RQ
* - * - * - * - * - * - * - * - * - * - * - * - *	

Toxic Substances Control Act:

The components of this product are listed on the TSCA Inventory.

Ozone Depleting Substances:

This product contains no ozone depleting substances as defined by the Clean Air Act.

Hazardous Air Pollutants:

Any components listed below are defined by the Federal EPA as hazardous air pollutants.

Component
* - * - * - * - * - * - * - * - * - * - * - * - *

STATE REGULATIONS:

This product contains mineral oil, and as used, may be regulated by state used oil regulations. Check with the appropriate state agency to determine whether such a regulation exists.

No further data known.

SECTION 16 - OTHER INFORMATION

Prepared by : Corporate Regulatory Compliance
Date of issue : 07/26/2007
Last Revision Date : 11/01/2006
C4302368

FUCHS LUBRICANTS CO.



PRODUCT NAME: GERALYN AW 68

NOTICE: This MSDS provides a good faith representation of information believed to be accurate as of the last revision date. This document does not create any express or implied product warranties. Since conditions of use are beyond the control of Fuchs Lubricants Co., all risks associated with product use are assumed by the user.



Revision Date: 04/12/2006

Issue date: 04/12/2006

1. CHEMICAL PRODUCT AND COMPANY IDENTIFICATION

Product name: 242® Threadlocker
Product type: Anaerobic Sealant
Company address:
Henkel Corporation
1001 Trout Brook Crossing
Rocky Hill, Connecticut 06067

Item No. : 24231
Region: United States
Contact Information:
Telephone: 860.571.5100
Emergency telephone: 860.571.5100
Internet: www.loctite.com

2. COMPOSITION/INFORMATION ON INGREDIENTS

<u>Hazardous components</u>	<u>%</u>	<u>ACGIH TLV</u>	<u>OSHA PEL</u>	<u>OTHER</u>
Polyglycol dimethacrylate 25852-47-5	60-100	None	None	None
Polyglycol oleate 9004-96-0	10-30	None	None	None
Saccharin 81-07-2	1-5	None	None	None
Silica, amorphous, fumed, crystalline-free 112945-52-5	1-5	6 mg/m ³ TWA	10 mg/m ³ TWA	3 mg/m ³ TWA respirable dust
Cumene hydroperoxide 80-15-9	1-5	None	None	1 ppm (6 mg/m ³) Skin (WEEL), 1ppm, skin TWA, (WEEL)
Propylene glycol 57-55-6	1-5	None	None	10 mg/m ³ TWA, (WEEL)

3. HAZARDS IDENTIFICATION

EMERGENCY OVERVIEW

HMIS:

Physical state: Liquid
Color: Blue
Odor: Mild

HEALTH: 2*
FLAMMABILITY: 1
PHYSICAL HAZARD: 1
Personal Protection: See Section 8

WARNING: CAUSES EYE IRRITATION.
MAY CAUSE SKIN IRRITATION.
MAY CAUSE ALLERGIC SKIN REACTION.
MAY CAUSE RESPIRATORY TRACT IRRITATION.

Relevant routes of exposure: Skin, Inhalation, Eyes

Potential Health Effects

Inhalation: May cause respiratory tract irritation.
Skin contact: May cause allergic skin reaction. May cause skin irritation.
Eye contact: Contact with eyes will cause irritation.
Ingestion: Not expected to be harmful by ingestion.

Item No. : 24231

Product name: 242® Threadlocker

Existing conditions aggravated by exposure:

Eye, skin, and respiratory disorders.

See Section 11 for additional toxicological information.

4. FIRST AID MEASURES

Inhalation: Remove to fresh air. If symptoms develop and persist, get medical attention.

Skin contact: Wash with soap and water. Remove contaminated clothing and shoes. Wash clothing before reuse. Get medical attention if symptoms occur.

Eye contact: Flush with copious amounts of water, preferably, lukewarm water for at least 15 minutes, holding eyelids open all the time. Get medical attention.

Ingestion: Do not induce vomiting. Keep individual calm. Obtain medical attention.

5. FIRE-FIGHTING MEASURES

Flash point: Greater than 93°C (200°F) Tagliabue closed cup

Autoignition temperature: Not available

Flammable/Explosive limits-lower %: 2.6 % (propylene glycol)

Flammable/Explosive limits-upper %: 12.5 % (propylene glycol)

Extinguishing media: Foam, dry chemical or carbon dioxide.

Special fire fighting procedures: None

Unusual fire or explosion hazards: None

Hazardous combustion products: Oxides of carbon. Oxides of sulfur. Oxides of nitrogen. Irritating organic vapors.

6. ACCIDENTAL RELEASE MEASURES

Environmental precautions: Prevent product from entering drains or open waters.

Clean-up methods: Soak up with inert absorbent. Store in a partly filled, closed container until disposal.

7. HANDLING AND STORAGE

Handling: Avoid contact with eyes, skin and clothing. Avoid breathing vapor and mist. Wash thoroughly after handling.

Storage: For safe storage, store at or below 38°C (100°F). Keep in a cool, well ventilated area away from heat, sparks and open flame. Keep container tightly closed until ready for use.

Incompatible products: Refer to Section 10.

For information on product shelf life contact Henkel Customer Service at (800) 243-4874.

8. EXPOSURE CONTROLS / PERSONAL PROTECTION

Engineering controls: No specific ventilation requirements noted, but forced ventilation may still be required if concentrations exceed occupational exposure limits.

Item No. : 24231

Product name: 242® Threadlocker

Respiratory protection: Use NIOSH approved respirator if there is potential to exceed exposure limit(s).

Skin protection: Use impermeable gloves and protective clothing as necessary to prevent skin contact. Neoprene gloves. Butyl rubber gloves. Natural rubber gloves.

Eye/face protection: Safety goggles or safety glasses with side shields.

See Section 2 for exposure limits.

9. PHYSICAL AND CHEMICAL PROPERTIES

Physical state: Liquid
Color: Blue
Odor: Mild
Vapor pressure: Less than 5 mm Hg at 27°C (80°F)
pH: Not applicable
Boiling point/range: Greater than 149°C (300°F)
Melting point/range: Not available
Specific gravity: 1.1 at 23.9°C (75°F)
Vapor density: Not available
Evaporation rate: Not available
Solubility in water: Slight
Partition coefficient (n-octanol/water): Not available
VOC content: 4.48%; 49.3 grams/liter (EPA Method 24)

10. STABILITY AND REACTIVITY

Stability: Stable.

Hazardous polymerization: Will not occur.

Hazardous decomposition products: Oxides of carbon. Oxides of sulfur. Oxides of nitrogen. Irritating organic vapors.

Incompatibility: Strong oxidizers. Free radical initiators. Strong reducing agents. Alkalis. Oxygen scavengers. Other polymerization initiators. Copper. Iron. Zinc. Aluminum. Rust.

Conditions to avoid: See "Handling and Storage" (Section 7) and "Incompatibility" (Section 10).

11. TOXICOLOGICAL INFORMATION

Product toxicity data: Acute oral LD50 greater than 10, 000 mg/kg (rat). Acute dermal LD50 greater than 5000 mg/kg (rabbit).

Carcinogen Status

Hazardous components	NTP Carcinogen	IARC Carcinogen	OSHA Carcinogen
Polyglycol dimethacrylate 25852-47-5	No	No	No
Polyglycol oleate 9004-96-0	No	No	No
Saccharin 81-07-2	No	No	No
Silica, amorphous, fumed, crystalline-free 112945-52-5	No	No	No
Cumene hydroperoxide 80-15-9	No	No	No
Propylene glycol 57-55-6	No	No	No

Literature Referenced Target Organ & Other Health Effects

Item No. : 24231

3 of 5

Product name: 242® Threadlocker

Hazardous components	Health Effects/Target Organs
Polyglycol dimethacrylate 25852-47-5	Allergen, Irritant
Polyglycol oleate 9004-96-0	Irritant
Saccharin 81-07-2	No Target Organs
Silica, amorphous, fumed, crystalline-free 112945-52-5	Nuisance dust
Cumene hydroperoxide 80-15-9	Allergen, Central nervous system, Corrosive, Irritant, Mutagen
Propylene glycol 57-55-6	Irritant

12. ECOLOGICAL INFORMATION

Ecological information: Not available

13. DISPOSAL CONSIDERATIONS

Information provided is for unused product only.

Recommended method of disposal: Dispose of according to Federal, State and local governmental regulations.

EPA hazardous waste number: Not a RCRA hazardous waste.

14. TRANSPORT INFORMATION

U.S. Department of Transportation Ground (49 CFR):

Proper shipping name: Unrestricted
Hazard class or division: None
Identification number: None
Packing group: None

International Air Transportation (ICAO/IATA):

Proper shipping name: Unrestricted
Hazard class or division: None
Identification number: None
Packing group: None

Water Transportation (IMO/IMDG):

Proper shipping name: Unrestricted
Hazard class or division: None
Identification number: None
Packing group: None
Marine pollutant: None

15. REGULATORY INFORMATION

United States Regulatory Information

TSCA 8 (b) Inventory Status:	All components are listed or are exempt from listing on the Toxic Substances Control Act Inventory.
TSCA 12 (b) Export Notification:	4-Methoxyphenol (150-76-5).
CERCLA/SARA Section 302 EHS:	None above reporting de minimus.
CERCLA/SARA Section 311/312:	Immediate Health Hazard, Delayed Health Hazard
CERCLA/SARA 313:	This product contains the following toxic chemicals subject to the reporting requirements of section 313 of the Emergency Planning and Community Right-To-Know Act of 1986 (40 CFR 372). Cumene hydroperoxide (CAS# 80-15-9) .
California Proposition 65:	This product contains a chemical known to the State of California to cause cancer and birth defects or other reproductive harm.

Canada Regulatory Information

CEPA DSL/NDSL Status:	All components are listed on or are exempt from listing on the Domestic Substances List.
WHMIS hazard class:	D.2.B

16. OTHER INFORMATION

This material safety data sheet contains changes from the previous version in sections: 15

Prepared by: Kyra Kozak Woods, Product Safety and Regulatory Affairs Specialist

DISCLAIMER: The data contained herein are furnished for information only and are believed to be reliable. However, Henkel Corporation does not assume responsibility for any results obtained by persons over whose methods Henkel Corporation has no control. It is the user's responsibility to determine the suitability of Henkel's products or any production methods mentioned herein for a particular purpose, and to adopt such precautions as may be advisable for the protection of property and persons against any hazards that may be involved in the handling and use of any of Henkel Corporation's products. In light of the foregoing, Henkel Corporation specifically disclaims all warranties, express or implied, including warranties of merchantability and fitness for a particular purpose, arising from sale or use of Henkel Corporation's products. Henkel Corporation further disclaims any liability for consequential or incidental damages of any kind, including lost profits.



Revision Date: 04/01/2004

Issue date: 04/01/2004

1. CHEMICAL PRODUCT AND COMPANY IDENTIFICATION

Product name: Loctite(R) 7649 Primer N
Product type: Accelerator
Company address:
Henkel Corporation
1001 Trout Brook Crossing
Rocky Hill, Connecticut 06067

Item number: 19269
Region: United States
Contact Information:
Telephone: 860.571.5100
Emergency telephone: 860.571.5100
Internet: www.loctite.com

2. COMPOSITION/INFORMATION ON INGREDIENTS

<u>Hazardous components</u>	<u>%</u>	<u>ACGIH TLV</u>	<u>OSHA PEL</u>	<u>OTHER</u>
Acetone 67-64-1	60-100	500 ppm TWA 750 ppm STEL	1000 ppm TWA 2400 mg/m ³ TWA	None
2-Ethylhexanoic acid 149-57-5	0.1-1	5 mg/m ³ TWA	None	None

3. HAZARDS IDENTIFICATION

EMERGENCY OVERVIEW

HMIS:

Physical state: Liquid
Color: Green
Odor: Acetone

HEALTH: 2*
FLAMMABILITY: 3
PHYSICAL HAZARD: 0
Personal Protection: See Section 8

DANGER: FLAMMABLE LIQUID AND VAPOR.
CAUSES EYE AND SKIN IRRITATION.
MAY CAUSE RESPIRATORY TRACT IRRITATION.

Relevant routes of exposure: Inhalation, Skin contact, Eye contact, Ingestion

Potential Health Effects

Inhalation: Harmful if inhaled. Vapors and mists will irritate nose and throat and possibly eyes. May cause respiratory tract irritation. Headache, dizziness, nausea, and loss of coordination are indications of excessive exposure to vapors or spray mists.

Skin contact: May cause skin irritation. Solvent action can dry and defat the skin, causing the skin to crack, leading to dermatitis.

Eye contact: Vapors may irritate eyes. Contact with eyes will cause irritation.

Ingestion: Harmful if swallowed.

Existing conditions aggravated by exposure: Eye, skin, and respiratory disorders.

See Section 11 for additional toxicological information.

4. FIRST AID MEASURES

Inhalation:	Remove to fresh air. If discomfort persists seek medical attention.
Skin contact:	Wash with soap and water.
Eye contact:	Flush with copious amounts of water, preferably, lukewarm water for at least 15 minutes, holding eyelids open all the time.
Ingestion:	If conscious, drink plenty of water. Do not induce vomiting. Keep individual calm. Obtain medical attention.

5. FIRE-FIGHTING MEASURES

Flash point:	-20°C (-4°F) (estimated)
Autoignition temperature:	465°C (869°F)
Flammable/Explosive limits-lower %:	2.6 %
Flammable/Explosive limits-upper %:	13 %
Extinguishing media:	Foam, dry chemical or carbon dioxide.
Special fire fighting procedures:	None
Unusual fire or explosion hazards:	Vapors may accumulate in low or confined areas, travel considerable distance to source of ignition, and flash back.
Hazardous combustion products:	Oxides of carbon. Oxides of nitrogen. Irritating organic vapors.

6. ACCIDENTAL RELEASE MEASURES

Environmental precautions:	Prevent product from entering drains or open waters.
Clean-up methods:	Remove all ignition sources. Ensure adequate ventilation. Soak up with inert absorbent. Store in a closed container until ready for disposal.

7. HANDLING AND STORAGE

Handling:	Avoid contact with eyes, skin and clothing. Avoid breathing vapor and mist. Wash thoroughly after handling. During use and until all vapors are gone: Keep area ventilated - do not smoke; extinguish all flames, pilot lights, and heaters; turn off stoves, electrical tools and appliances, and any other sources of ignition.
Storage:	Store away from heat, sparks, flames, or other sources of ignition. For safe storage, store at or below 49°C (120°F).
Incompatible products:	Refer to Section 10.

For information on product shelf life contact Henkel Customer Service at (800) 243-4874.

8. EXPOSURE CONTROLS / PERSONAL PROTECTION

Engineering controls:	Use local ventilation if general ventilation is insufficient to maintain vapor concentration below established exposure limits.
Respiratory protection:	Use NIOSH approved respirator if there is potential to exceed exposure limit(s).

Item number: 19269

Product name: Loctite(R) 7649 Primer N

Skin protection: Chemical resistant, impermeable gloves.
Eye/face protection: Safety goggles or safety glasses with side shields.

See Section 2 for exposure limits.

9. PHYSICAL AND CHEMICAL PROPERTIES

Physical state: Liquid
Color: Green
Odor: Acetone
Vapor pressure: 172 mmHg at 20 °C (68 °F)
pH: Not applicable
Boiling point/range: 56°C (133°F)
Melting point/range: Not available
Specific gravity: 0.7936
Vapor density: 2.0
Evaporation rate: 1.9 (Ether = 1)
Solubility in water: Completely miscible
Partition coefficient (n-octanol/water): Not available
VOC content: 1.48%; 11.7 grams/liter (EPA Method 24)

10. STABILITY AND REACTIVITY

Stability: Stable.
Hazardous polymerization: Will not occur.
Hazardous decomposition products: Oxides of carbon. Oxides of nitrogen. Irritating organic vapors.
Incompatibility: Strong oxidizers.
Conditions to avoid: See "Handling and Storage" (Section 7) and "Incompatibility" (Section 10).

11. TOXICOLOGICAL INFORMATION

Carcinogen Status

Hazardous components	NTP Carcinogen	IARC Carcinogen	OSHA Carcinogen
Acetone	No	No	No
2-Ethylhexanoic acid	No	No	No

Literature Referenced Target Organ & Other Health Effects

Hazardous components	Health Effects/Target Organs
Acetone	Blood, Central nervous system, Irritant, Reproductive
2-Ethylhexanoic acid	Developmental, Eyes, Irritant, Liver, Reproductive

12. ECOLOGICAL INFORMATION

Ecological information: Not available

13. DISPOSAL CONSIDERATIONS

Information provided is for unused product only.

Recommended method of disposal: Dispose of according to Federal, State and local governmental regulations.

EPA hazardous waste number: D001: Ignitable.

Item number: 19269

Product name: Loctite(R) 7649 Primer N

14. TRANSPORT INFORMATION

U.S. Department of Transportation Ground (49 CFR):

Proper shipping name: Acetone
Hazard class or division: 3
Identification number: UN 1090
Packing group: II
Exceptions: Consumer Commodity ORM-D (Not more than 1 Liter)

International Air Transportation (ICAO/IATA):

Proper shipping name: Acetone
Hazard class or division: 3
Identification number: UN 1090
Packing group: II
Exceptions: Consumer Commodity ID8000 (Not more than 500 ml)

WaterTransportation (IMO/MDG):

Proper shipping name: Acetone
Hazard class or division: 3
Identification number: UN 1090
Packing group: II
Exceptions: Dangerous goods in limited quantities of class 3 (Not more than 1 liter(s))
Marine pollutant: None

15. REGULATORY INFORMATION

United States Regulatory Information

TSCA 8 (b) Inventory Status: All components are listed or are exempt from listing on the Toxic Substances Control Act Inventory.
TSCA 12 (b) Export Notification: Acetone (CAS# 67-64-1).

CERCLA/SARA Section 302 EHS: None.
CERCLA/SARA Section 311/312: Immediate Health Hazard, Delayed Health Hazard, Fire
CERCLA/SARA 313: None above reporting de minimus.

California Proposition 65: This product contains a chemical known to the State of California to cause cancer and birth defects or other reproductive harm. Nickel (CAS# 7440-02-0). Cobalt (CAS# 7440-48-4). Formaldehyde (CAS# 50-00-0). Acetaldehyde (CAS# 75-07-0). Benzene (CAS# 71-43-2).

Canada Regulatory Information

CEPA DSL/NDSL Status: All components are listed on or are exempt from listing on the Domestic Substances List.
WHMIS hazard class: B.2, D.2.A, D.2.B

16. OTHER INFORMATION

This material safety data sheet contains changes from the previous version in sections: Expanded chemical information in Section 2 and related sections.

Prepared by: Kyra Kozak Woods, Health and Regulatory Affairs Specialist

DISCLAIMER: The data contained herein are furnished for information only and are believed to be reliable. However, Henkel Corporation does not assume responsibility for any results obtained by persons over whose methods Henkel Corporation has no control. It is the user's responsibility to determine the suitability of Henkel's products or any production methods mentioned herein for a particular purpose, and to adopt such precautions as may be advisable for the protection of property and persons against any hazards that may be involved in the handling and use of any of Henkel Corporation's products. In light of the foregoing, Henkel Corporation specifically disclaims all warranties, express or implied, including warranties of merchantability and fitness for a particular purpose, arising from sale or use of Henkel Corporation's products. Henkel Corporation further disclaims any liability for consequential or incidental damages of any kind, including lost profits.

Item number: 19269

Product name: Loctite(R) 7649 Primer N

4 of 4