



STREAMLINE SL-V 75 *PLUS*

WATERJET INTENSIFIER

OPERATION AND MAINTENANCE MANUAL



NOTICE

This document contains subject matter in which KMT Waterjet Systems has proprietary rights. Recipients of this document shall not duplicate, use or disclose information contained herein, in whole or in part, for other than the purpose for which this manual was provided.

KMT Waterjet believes the information described in this manual to be accurate and reliable. Much care has been taken in its preparation; however, the Company cannot accept any responsibility, financial or otherwise, for any consequences arising out of the use of this material. The information contained herein is subject to change, and revisions may be issued advising of such changes and/or additions.

KMT WATERJET SYSTEMS 2012



KMT Waterjet Systems
635 West 12th Street
PO 231
Baxter Springs, KS 66713-0231

Phone: (800) 826-9274
Fax: (620) 856-5050

TABLE OF CONTENTS

Title Page
 Notice
 Table of Contents
 Appendix

<i>Section</i>	<i>Page</i>
1 Introduction.....	1-1
1.1 Overview.....	1-1
1.2 Performance Features and Options.....	1-1
1.3 Operational Overview.....	1-3
Low Pressure Water System.....	1-3
Recirculation System.....	1-3
Hydraulic System.....	1-3
High Pressure Water System.....	1-3
Operating System.....	1-4
1.4 Safety.....	1-5
Lockout/Tagout Procedure.....	1-5
Warning Labels.....	1-6
Emergency Medical Treatment.....	1-8
1.5 Worldwide Product Support.....	1-8
1.6 Spare Parts.....	1-9
1.7 Manual Organization.....	1-9
1.8 Equipment and Service Manual Questionnaire.....	1-10
Terms and Conditions of Sale	
Terms and Conditions, Part Sales	
Terms LD-146, Domestic Service Supervisor	
Terms LD-147, International Service Supervisor	
2 Installation.....	2-1
2.1 Overview.....	2-1
2.2 Installation Summary.....	2-1
2.3 Site Requirements.....	2-2
Transporting.....	2-3
2.4 Power Requirements.....	2-4
2.5 Service Connections.....	2-5
Cooling Water (Oil-to-Water Models).....	2-6
Cutting Water.....	2-7
Drain.....	2-7
Plant Air.....	2-8
Contaminated Waste Drain.....	2-8

2.6	Flow Requirements	2-9
2.7	High Pressure Piping.....	2-9
	Measurements and Dimensions	2-10
	Hand Coning.....	2-11
	Power Coning.....	2-12
	Hand Threading	2-13
	Power Threading.....	2-13
2.8	High Pressure Connections	2-14
	Standard Connections	2-14
	Anti-Vibration Connections.....	2-15
2.9	Commissioning	2-16
2.10	Decommissioning	2-19
3	Maintenance	3-1
3.1	Overview.....	3-1
3.2	Maintenance.....	3-1
	Daily Inspection	3-1
	Periodic Maintenance.....	3-1
	High Pressure System Maintenance.....	3-2
3.3	Maintenance Precautions	3-3
3.4	Tool Kits	3-3
4	Operation	4-1
4.1	Overview.....	4-1
4.2	Startup Sequence.....	4-2
	Startup after Motor Stop	4-2
	Startup after Emergency Stop	4-2
4.3	Display Controls	4-3
4.4	Main Menu.....	4-4
4.5	Run Screens	4-5
4.6	Pressure Control Screen.....	4-6
4.7	Setup Screens	4-7
4.8	Stroke Rate Screens	4-8
4.9	Hours Screens	4-10
4.10	Run Screen Alarms	4-11
4.11	Alarm Banners	4-13
4.12	Alarms Screen.....	4-14
	Installing a New Battery	4-16
4.13	Alarm History	4-16
	Changing the Date and Time	4-17
4.14	Configuration Screen	4-17
4.15	Maintenance Screen	4-17
4.16	Language Screen.....	4-18

5	Low Pressure Water System	5-1
5.1	Overview.....	5-1
5.2	Cutting Water Supply	5-2
5.3	Operation.....	5-2
5.4	Service and Maintenance Procedures	5-4
	Filter Assembly and Strainer Maintenance.....	5-4
	Booster Pump Adjustment	5-5
6	Recirculation System	6-1
6.1	Overview.....	6-1
6.2	Operation (Oil-to-Water Models)	6-1
6.3	Operation (Oil-to-Air Models).....	6-3
6.4	Service and Maintenance Procedures	6-4
	Hydraulic Oil Maintenance.....	6-4
	Electric Motor Bump	6-6
	Oil Filter Maintenance	6-7
	Operating Temperature Adjustment (Oil-to-Water Models)	6-8
7	Hydraulic System	7-1
7.1	Overview.....	7-1
7.2	Optional System Components.....	7-2
7.3	Operation.....	7-2
7.4	Service and Maintenance Procedures	7-4
	Hydraulic Operating Pressure	7-4
	Proportional Valve Maintenance	7-6
	Motor Maintenance.....	7-6
	Flexible Coupling Replacement.....	7-7
	Hydraulic Compensator Maintenance.....	7-9
	Hydraulic Pump or Electric Motor Replacement.....	7-12
	Hydraulic Oil Replacement.....	7-16
	Electric Motor Bump	7-17
8	Electrical System	8-1
8.1	Overview.....	8-1
8.2	Optional System Components.....	8-1
8.3	Operation.....	8-2
	Sensors and Solenoids.....	8-5
	Softstarter	8-9
8.4	Service and Maintenance Procedures	8-10
	Proximity Switch Maintenance.....	8-11
	Optical Relay Maintenance.....	8-12
9	High Pressure Water System	9-1
9.1	Overview.....	9-1
9.2	System Options	9-2
9.3	Operation.....	9-2

	Redundant Intensifiers	9-3
	Dual Intensifiers.....	9-4
9.4	System Components.....	9-5
9.5	Service and Maintenance Overview	9-6
	Torque Specifications	9-7
	Specialized Maintenance Tools	9-9
9.6	High and Low Pressure Water Piping.....	9-10
9.7	High Pressure Cylinder Assembly	9-10
	High Pressure Cylinder Assembly Removal.....	9-11
	High Pressure Cylinder Assembly Installation.....	9-12
	High Pressure Cylinder Maintenance	9-13
9.8	Hard Seal End Caps	9-14
	Hard Seal End Cap Removal	9-14
	Hard Seal End Cap Installation.....	9-15
9.9	Sealing Head.....	9-16
	High Pressure Discharge Check Valve	9-17
	Low Pressure Inlet Check Valve.....	9-18
	Sealing Head Maintenance	9-20
9.10	High Pressure Seal Assembly	9-20
9.11	Hydraulic Cartridge Seal and Plunger Removal.....	9-22
	Plunger Maintenance	9-25
	Plunger Installation	9-25
	Hydraulic Cartridge Seal.....	9-26
9.12	Hydraulic Piston.....	9-27
	Hydraulic Piston Removal	9-28
	Bearing Rings and Seal Assembly.....	9-29
	Plunger Button Sockets, Seals and Retainer Pins	9-29
	Internal Check Valves.....	9-30
	Hydraulic Piston Installation.....	9-31
9.13	Hydraulic Cylinder Maintenance.....	9-32
9.14	High Pressure Attenuator.....	9-32
9.15	High Pressure Dump Valve	9-33
	3-Port Pneumatic Control Dump Valve (SL-V 30, 50 and 60).....	9-33
	2-Port Pneumatic Control Dump Valve (SL-V 75, 100 and 100D).....	9-37
	Pneumatic Actuator.....	9-41
9.16	Weep Holes.....	9-42
10	Troubleshooting	10-1
	10.1 Overview.....	10-1
	10.2 Troubleshooting Guide	10-2
	10.3 Softstarter	10-12
11	Specifications	11-1
	11.1 Overview.....	11-1
	11.2 Installation Specifications.....	11-1
	Environment.....	11-1

	Sound Level	11-2
	Equipment Dimensions and Weights.....	11-2
	Service Connections.....	11-2
	Plant Air	11-3
11.3	Water Specifications	11-3
	Cutting Water Supply	11-3
	Cooling Water Supply.....	11-4
	Water Quality Standards	11-5
11.4	Electrical Specifications.....	11-7
	Electrical System	11-7
	Ampacity and Power Voltage Requirements	11-7
11.5	Hydraulic and High Pressure Water System Specifications	11-8
	Hydraulic System.....	11-8
	High Pressure Water System	11-8
	Orifice Capacity	11-9
11.6	Torque Specifications	11-11
12	Parts List.....	12-1
	12.1 Overview.....	12-1
	12.2 Index	12-2

APPENDIX

Exhibit

System Schematic
Electrical Schematic(s)
Material Safety Data Sheets



SECTION 1

INTRODUCTION

1.1 Overview

The Streamline SL-V Plus series combines all the unique capabilities and advantages of waterjet cutting systems with the reliability, ease of operation and service support that have made KMT Waterjet Systems a leader in waterjet technology.

With 30, 50, 60, 75 and 100 horsepower single and redundant models, as well as a 100 horsepower dual model, the SL-V series accommodates a wide range of applications. From small, single head requirements to high volume production requiring multi-head systems; from intricate detailed cutting, to rapid hole drilling; from titanium to produce, the SL-V series provides the solution.

Table 1-1
Streamline SL-V Plus Models

Model	Motor Horsepower Rating		Maximum Operating Pressure	Maximum Flow Rate (at full pressure)	Maximum Single Orifice Diameter (at fill pressure)
	HP	Kw			
SL-V 30	30	22	60,000 psi (4,137 bar)	0.52 gpm (2.0 L/min)	0.010 inch (0.254 mm)
SL-V 50	50	37		0.90 gpm (3.4 L/min)	0.013 inch (0.330 mm)
SL-V 60	60	45		1.02 gpm (3.9 L/min)	0.014 inch (0.356 mm)
SL-V 75	75	56		1.34 gpm (5.1 L/min)	0.016 inch (0.406 mm)
SL-V 100	100	75		1.88 gpm (7.1 L/min)	0.019 inch (0.483 mm)
SL-V 100D	100	75		1.88 gpm (7.1 L/min)	0.019 inch (0.483 mm)

1.2 Performance Features and Options

The SL-V series is designed with the same convenience and ease of access for maintenance and service you have come to expect from KMT Waterjet. The hydraulic cylinder head simply bolts to the hydraulic cylinder; each high pressure assembly can be removed and serviced independently, and the hydraulic seal cartridge can be quickly replaced as a single unit.

The robust performance and standard features are the result of aggressive development and decades of experience.

- Continuous operation at 60,000 psi (4,137 bar) affords faster cutting speeds, resulting in lower cost per inch.
- The innovative hard seal end cap provides a metal-to-metal seal against the sealing head, totally, eliminating the potential for leaks.
- While dramatically increasing seal life, the unique design of the patented HyperLife™ seal conforms to the cylinder bore as it expands under pressure, creating an absolute seal.



- The quick release design of the ceramic plunger greatly simplifies removal and installation.
- Each long, slow stroke of the plunger moves more water, while reducing seal and component wear.
- Comprehensive fault detection and troubleshooting logic monitor crucial pressure, temperature and fluid levels.
- Warning and shutdown sensors guard against potential equipment damage.

Performance options are available at the time of purchase, or as upgrades for existing equipment.

- The KMT Customer Service Department can provide real time diagnostics, troubleshooting and data analysis through a modem interface for remote monitoring of the programmable logic controller (PLC).
- Proportional pressure control allows the operator to select or vary the operating pressure from the control display or remote console.
- The current operating pressure can be viewed from the control display with an optional pressure transducer.

1.3 Operational Overview

The following provides a brief overview of the function and primary components associated with the individual systems. A detailed discussion of each system is provided in Sections 4 through 9.

Low Pressure Water System

The low pressure water system supplies the cutting water flow to the intensifier. Major system components include the water filter assembly and the booster pump.

Figure 1-1: System Components

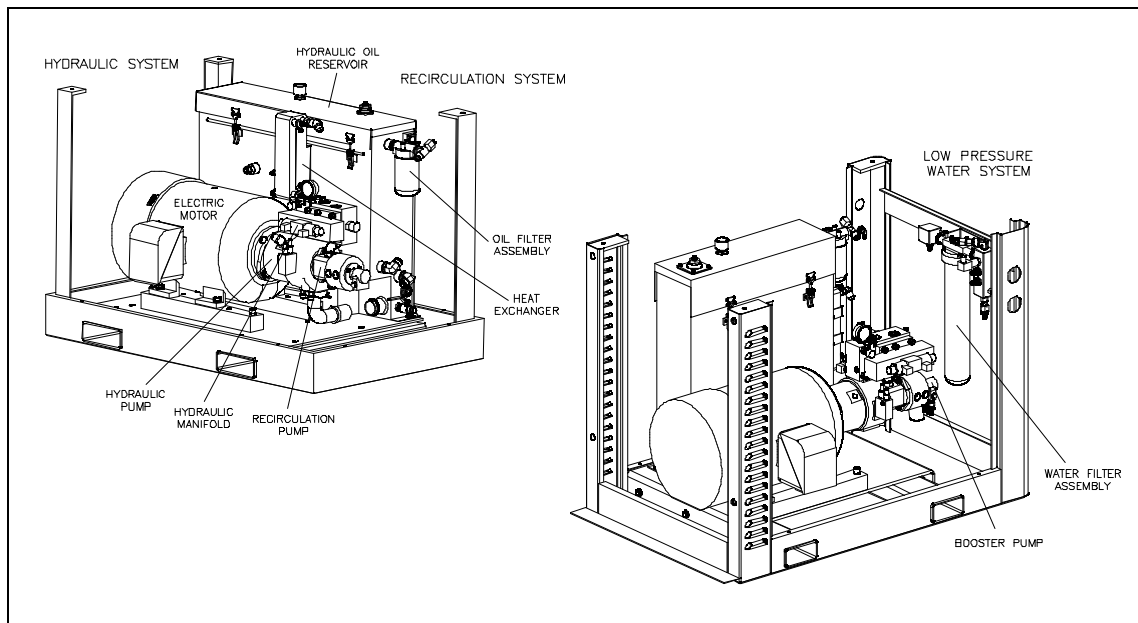

Recirculation System

The recirculation system is a cooling and filtration system that provides properly conditioned oil to the main hydraulic system. Major system components include the recirculation pump, heat exchanger, oil filter assembly and the hydraulic oil reservoir.

Hydraulic System

The hydraulic system supplies the intensifier with the hydraulic oil required to produce high pressure water. Major system components include the electric motor, hydraulic pump and a 4-way directional control valve mounted on the hydraulic manifold.

High Pressure Water System

The high pressure water system is the heart of the waterjet system. Water is pressurized and continuously delivered to the cutting head. As water passes through a tiny hole in the orifice, water pressure is converted to water velocity capable of cutting most any material.

The major components include the high pressure cylinder assemblies, hydraulic cylinder assembly, hydraulic piston, attenuator and the safety dump valve.

Figure 1-2: High Pressure Water System Components

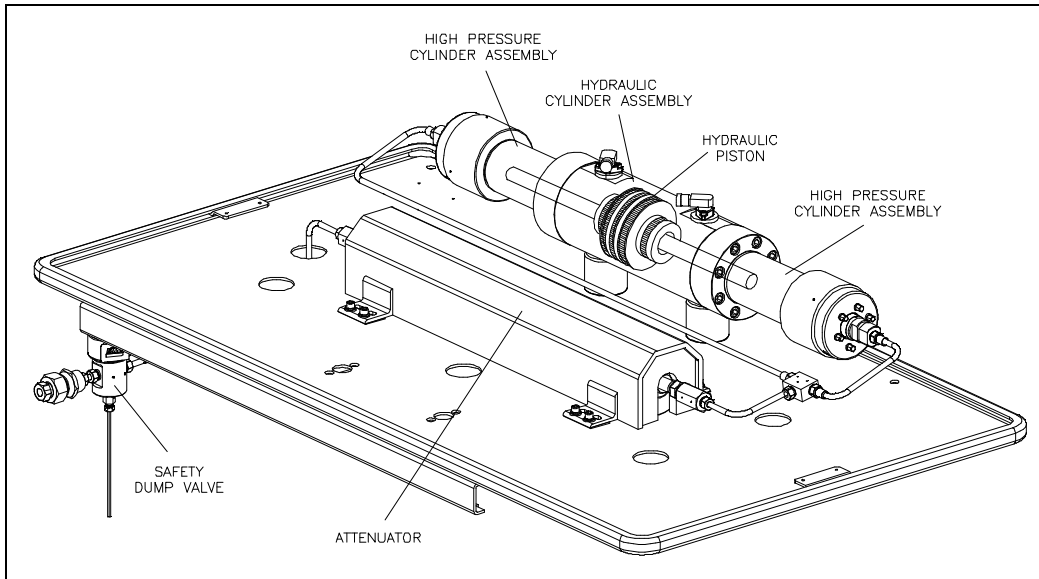

Operating System

A programmable logic controller (PLC) provides basic intensifier shift control and monitors out of limit conditions. Operator interface is through the control panel display where operating parameters are set and monitored.

Figure 1-3: Control Panel Main Menu



1.4 Safety

The high pressure waterjet cutting system is a high energy cutting tool capable of cutting many dense or strong materials. Do not touch or be exposed to high pressure water. High pressure water will penetrate all parts of the human body. The liquid stream and the material ejected by the extreme pressure can result in severe injury.

All personnel operating, servicing or working near the waterjet cutting equipment shall adhere to the following safety precautions, as well as the applicable plant safety precautions.

- Only KMT factory trained, qualified personnel shall service and maintain the equipment.
- The operator shall practice and promote safety at all times to avoid potential injury and unnecessary downtime.
- The work area around the equipment shall be clean and free of debris and oil spills.
- All protective guards, shields or covers shall be in place on the equipment at all times.
-  Safety glasses and ear protection shall be worn when operating or working near the equipment.

Lockout/Tagout Procedure

This lockout/tagout procedure is designed to protect all employees from injuries caused by the unexpected energizing or startup of the machine, or the release of stored energy during service and maintenance.

This is accomplished with energy isolating devices that prevent the transmission or release of energy. An energy source is any source of electrical, mechanical, hydraulic, pneumatic, chemical, thermal, or other energy source that could cause injury to personnel.

A lockout device utilizes a lock and key to hold an energy isolating device in the safe position and prevents the machine from being energized. A tagout device is a prominent warning device that can be securely attached to the machine warning personnel not to operate the energy isolating device. This procedure requires the combination of a lockout device and a tagout device.

The lockout/tagout procedure applies to any employee who operates and/or performs service or maintenance on the machine. Before any maintenance or repairs are performed, the machine shall be isolated, and rendered inoperative as follows.

1. Shut down the machine by pressing the stop button, and open the high pressure cutting water valve to bleed the water and hydraulic pressure from the system.
2. Disconnect, lockout and tag the main, customer supplied, power source.
3. Lockout and tag the circuit breaker/disconnect on the electrical enclosure door.

4. Close, lockout and tag the manual shutoff valves for all service connections: cutting water in, cooling water in and out, and air.

Warning Labels

Warning labels are posted on the machine to indicate potential hazards. The operator and service personnel shall pay particular attention to these warning labels. Table 1-2 describes the necessary precautions and provides the part number required to order replacement labels.

Table 1-2
Warning Label Precautions



1		<p>The electrical enclosure and motor junction box can present an electrical shock hazard. Always disconnect and lockout the main power before opening the enclosure.</p> <p>Always disconnect and lockout the main power and the circuit breaker/disconnect on the electrical enclosure door before performing any type of maintenance.</p>
	P/N 05114962	
2		<p>The surface of high pressure water and hydraulic components becomes hot during normal operation. Failed, or failing components, can become extremely hot during operation.</p>
	P/N 05114970	
3		<p>Ensure that all protective guards, shields or covers are in place on the equipment at all times. Never operate the pump with the guards removed.</p>
	P/N 80082209	

Table 1-2
Warning Label Precautions

4

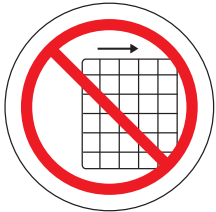

P/N 05098017

High pressure water and/or hydraulic pressure can remain in the system even when the pump has been shut off. All pressure can be safely bled from the system by opening the high pressure cutting water valve for a few seconds after shutting off the pump.

Pressing the emergency stop button turns the control power to the intensifier off, stops the pump and bleeds the high pressure water through the safety dump valve.

Depressurization of the high pressure system creates a loud hissing sound when the dump valve opens. The sound fades quickly as the pressure drops.

5



P/N 20415794

All personnel involved in the installation, operation and/or service of the intensifier must carefully read, understand and follow the procedures in this manual to avoid creating unsafe conditions, risking damage to the equipment, or personal injury.

Safety precautions and warnings for specific procedures are emphasized throughout this manual as illustrated in the following examples. These precautions must be reviewed and understood by operating and maintenance personnel prior to installing, operating or servicing the machine. Adherence to all Warnings, Cautions and Notes is essential to safe and efficient service and operation.



Warnings emphasize operating or service procedures, or conditions that can result in serious personal injury or death.



Cautions emphasize operating or service procedures, or conditions that can result in equipment damage or impairment of system operation.

NOTE

Notes provide additional information that can expedite or improve operating or service procedures.

Emergency Medical Treatment

An emergency medical card is included in the binder of this manual. This information should be used to aid in the treatment of a waterjet injury. Additional cards may be obtained by contacting KMT Waterjet Systems using the address or telephone number shown on the card.

Medical Alert

This card is to be carried by personnel working with high pressure waterjet equipment. Obtain medical treatment immediately for ANY high pressure waterjet injuries.

KMT Waterjet Systems
635 West 12th Street
Baxter Springs, KS 66713
(620) 856-2151

This person has been working with water jetting at pressures to 60,000 psi (374MPa, 4,137 bar, 3867 Kg/cm²) with a jet velocity of 3,000 fps (914 mps). Foreign material (sand) may have been injected with water. Unusual infections with microaerophilic organisms occurring at lower temperatures have been reported, such as gram negative pathogens as are found in sewage. Bacterial swabs and blood cultures may therefore be helpful. This injury must be treated as an acute surgical emergency and be evaluated by a qualified surgeon. Circulation may be compromised, therefore, **DO NOT APPLY HEAT TO INJURED PART**. For first aid: (1) Elevate injured part (2) Antibiotics (3) Keep injured person NPO.

1.5 Worldwide Product Support

The KMT Waterjet Customer Service Department is available to answer your questions regarding equipment installation and service. Technical assistance is available by phone and on-site support is available on request.

On-site technical assistance is available during equipment installation and startup. Additionally, technical support for service and maintenance issues and training of operators and maintenance personnel is available. Periodic training sessions are also conducted at KMT Waterjet and customer facilities.



Contact the KMT Waterjet Customer Service Department for additional information.

USA Customer Service Department

KMT Waterjet Systems
PO Box 231
635 West 12th Street
Baxter Springs, KS 66713
USA

Phone: (800) 826-9274
Fax: (620) 856-2242
Email: wj.service@kmtwaterjet.com
Email: wj.parts@kmtwaterjet.com

Europe Technical Manager

KMT Waterjet Systems GmbH
Wasserstrahl-Schneidetechnik
Auf der Laukert 11
D-61231 Bad Nauheim
Germany

Phone: +49-6032-997-117
Fax: +49-6032-997-270
Email: order.service@kmt-waterjet.com

1.6 Spare Parts

KMT Waterjet maintains a well-stocked Spare Parts Department, staffed by trained, knowledgeable personnel. If required, emergency shipment is available. Contact the Customer Service Department to order spare parts, or for additional information.

1.7 Manual Organization

This manual contains operating and maintenance procedures for the complete SL-V series. Information is organized as follows:

- Section 1, Introduction, provides equipment features and options, a brief operational overview, details regarding safety issues and contact information for product support.
- Section 2, Installation, details installation requirements and procedures. Systematic guidelines for commissioning the intensifier are also provided.
- Section 3, Maintenance, highlights routine and preventive maintenance requirements. Precautions associated with high pressure cutting equipment are also reviewed.
- Section 4, Operation, explains the control functions and the display panel where operating parameters are set and monitored.
- Sections 5 through 9 are specific to each individual system. Each section contains a detailed description of the principles of operation and the function of each system. Routine maintenance procedures associated with the system are also included.
- Section 10, Troubleshooting, is a comprehensive guide containing the information required to diagnose problems and repair the machine.
- Section 11, Specifications, contains a comprehensive list of equipment specifications; a detailed discussion of water quality standards and treatment guidelines; as well as horsepower requirements for various orifice sizes.
- Section 12, Parts List, contains part numbers, descriptions and drawings to facilitate the ordering of replacement parts.



1.8 Equipment and Service Manual Questionnaire

We are interested in your impression of the KMT Waterjet System recently installed at your location. Your comments and recommendations will aid us in our continuing goal to improve our products, and make our technical information more useful to our customers.

At your convenience, please take a few minutes to complete the following questionnaire, and return it to the applicable Customer Service Department listed above.



Equipment and Service Manual Questionnaire

1. General Appearance

Was the unit received in good condition? Yes No

Comments: _____

Is the unit a convenient size? Yes No

2. Controls

Are the controls user friendly? Yes No

Is the unit easy to operate? Yes No

Comments: _____

3. Performance

Does the unit perform smoothly and meet your expectations? Yes No

Does the unit run quietly? Yes No

Comments: _____

4. Did the installation and startup go smoothly? Yes No

Comments: _____

5. What features do you consider the most significant?

Quiet operation _____

Appearance _____

Performance/Operation _____

Repair/Maintenance _____

Other _____

6. What areas could be improved?

Appearance _____

Performance _____

Serviceability _____

Other _____



7. Manual Organization

Does the Table of Contents help you find topics easily? Yes No

Comments: _____

Is the information well organized? Yes No

Comments: _____

Is the page layout suitable for the material being presented? Yes No

Comments: _____

8. Graphics

Are the illustrations suitable for the material being presented? Yes No

Comments: _____

9. Text

Does the information adequately explain how to operate and service the equipment? Yes No

Comments: _____

Are there paragraphs or procedures you feel need clarification? Please identify them by page number and add your comments. Yes No

Comments: _____

Is there anything you would add or delete to make the manual more useful? Yes No

Comments: _____

Is there any information that should receive more emphasis? Yes No

Comments: _____

Name _____ Title _____

Company _____ Date _____

Address _____



Terms and Conditions of Sale

1. General

The Terms and Conditions of Sale outlined herein shall apply to the sale by KMT Waterjet Systems Inc. (hereinafter referred to as Company) of products, equipment and parts relating thereto (hereinafter referred to as Equipment). Unless prior written agreement is reached, it shall be understood that the Company's proceeding with any work shall be in accordance with the terms and conditions outlined herein

The Company will comply with applicable laws and regulations in effect on the date of the Company's proposal as they may apply to the manufacture of the Equipment. Compliance with any local governmental laws or regulations relating to the location, use or operation of the Equipment, or its use in conjunction with other equipment, shall be the sole responsibility of the Purchaser.

2. Title and Risk of Loss

Title and risk of loss or damage to the Equipment shall pass to the Purchaser upon tender of delivery F.O.B. manufacturing facility unless otherwise agreed upon by the parties, except that a security interest in the Equipment shall remain in the Company, regardless of mode of attachment to realty or other property, until full payment has been made therefor. Purchaser agrees upon request to do all things and acts necessary to perfect and maintain said security interest and shall protect Company's interest by adequately insuring the Equipment against loss or damage from any cause wherein the Company shall be named as an additional insured.

3. Assignment

Neither party shall assign or transfer this contract without the prior written consent of the other party. The Company however shall be permitted to assign or transfer, without the prior written consent of the Purchaser, the Company's right to receive all or any portion of the payment due from the Purchaser under this contract.

4. Delivery and Delays

Delivery dates shall be interpreted as estimated and in no event shall dates be construed as falling within the meaning of "time is of the essence".

The Company shall not be liable for any loss or delay due to war, riots, fire, flood, strikes or other labor difficulty, acts of civil or military authority including governmental laws, orders, priorities or regulations, acts of the Purchaser, embargo, car shortage, damage or delay in transportation, inability to obtain necessary labor or materials from usual sources, faulty forgings or castings, or other causes beyond the reasonable control of the Company. In the event of delay in performance due to any such cause, the date of delivery or time for completion will be adjusted to reflect the actual length of time lost by reason of such delay. The Purchaser's receipt of Equipment shall constitute a waiver of any claims for delay.

5. Taxes

The price does not include any present or future Federal, State, or local property, license, privilege, sales, use, excise, gross receipts or other like taxes or assessments which may be applicable to, measured by, imposed upon or result from this transaction or any services performed in connection therewith. Such taxes will be itemized separately to Purchaser, who shall make prompt payment to the Company. The Company will accept a valid exemption certificate from Purchaser, if applicable. If such exemption certificate is not recognized by the governmental taxing authority involved, Purchaser agrees to promptly reimburse the Company for any taxes covered by such exemption certificate which the Company is required to pay.

6. Set Offs

Neither Purchaser nor any affiliated company or assignee shall have the right to claim compensation or to set off against any amounts which become payable to the Company under this contract or otherwise.

7. Patents

The Company shall defend any Suit or proceeding brought against the Purchaser and shall pay any adverse judgment entered therein so far as such suit or proceeding is based upon a claim that the use of the Equipment manufactured by the Company, and furnished under this contract constitutes infringement of any patent of the United States of America, providing the Company is promptly notified in writing and given authority, information and assistance for defense of same; and the Company shall, at its option, procure for the Purchaser the right to continue to use said Equipment, or to modify it so that it becomes non-infringing, or to replace the same with non-infringing equipment, or to remove said Equipment and to refund the purchase price. The foregoing shall not be construed to include any agreement by the Company to accept any liability whatsoever in respect to patents for inventions including more than the Equipment furnished hereunder or in respect of patents for methods and processes to be carried Out with the aid of said Equipment. The foregoing states the entire liability of the Company with regard to patent infringement.

8. Warranty

The Company warrants that the Equipment manufactured by it and delivered hereunder will be free of defects in material and workmanship for a period of twelve months from the date of placing the Equipment in operation or eighteen months from the date of shipment, whichever shall first occur. The Purchaser shall be obligated to promptly report any failure to conform to this warranty, in writing to the Company within said period, whereupon the Company shall, at its option, correct such nonconformity, by suitable repair to such Equipment or, furnish a replacement part in accordance with the following sentence, provided the Purchaser has stored, installed, maintained and operated such Equipment in accordance with good industry practices and has complied with specific recommendations of the Company. The Company shall pay for shipping costs of any such replacement part to the Purchaser's place of business via UPS Ground; provided that should the Purchaser request special shipping instruction such as exclusive use of shipping facilities, including air freight when common carrier has been quoted and before a change to the order is received by the Company, the additional charges will be honored by the Purchaser. Accessories or equipment furnished by the Company, but manufactured by others, shall carry whatever warranty the manufacturers have conveyed to the Company and which can be passed on to the Purchaser. The Company shall not be liable for any repairs, replacements, or adjustments to the Equipment or any costs of labor performed by the Purchaser or others without the Company's prior written approval.

The effects of corrosion, erosion and normal wear and tear are specifically excluded. Performance warranties are limited to those specifically stated within the Company's proposal. Unless responsibility for meeting such performance warranties are limited to specified shop or field tests, the Company's obligation shall be to correct in the manner and for the period of time provided above.

THE COMPANY MAKES NO OTHER WARRANTY OR REPRESENTATION OF ANY KIND WHATSOEVER, EXPRESSED OR IMPLIED, EXCEPT THAT OF TITLE, AND ALL IMPLIED WARRANTIES OF MERCHANTABILITY AND FITNESS FOR A PARTICULAR PURPOSE, ARE HEREBY DISCLAIMED.



Correction by the Company of nonconformities whether patent or latent, in the manner and for the period of time provided above, shall constitute fulfillment of all liabilities of the Company for such nonconformities, whether based on contract warranty, negligence, indemnity, strict liability or otherwise with respect to or arising out of such Equipment.

The Purchaser shall not operate Equipment which is considered to be defective, without first notifying the Company in writing of its intention to do so. Any such use of Equipment will be at the Purchaser's sole risk and liability.

9. Limitation of Liability

THE REMEDIES OF THE PURCHASER SET FORTH HEREIN ARE EXCLUSIVE, AND THE TOTAL LIABILITY OF THE COMPANY WITH RESPECT TO THIS CONTRACT OR THE EQUIPMENT AND SERVICES FURNISHED HEREUNDER, IN CONNECTION WITH THE PERFORMANCE OR BREACH THEREOF, OR FROM THE MANUFACTURE, SALE, DELIVERY, INSTALLATION, REPAIR OR TECHNICAL DIRECTION COVERED BY OR FURNISHED UNDER THIS CONTRACT, WHETHER BASED ON CONTRACT WARRANTY, NEGLIGENCE, INDEMNITY, STRICT LIABILITY OR OTHERWISE, SHALL NOT EXCEED THE PURCHASE PRICE OF THE UNIT OF EQUIPMENT UPON WHICH SUCH LIABILITY IS BASED.

THE COMPANY AND ITS SUPPLIERS SHALL IN NO EVENT BE LIABLE TO THE PURCHASER, ANY SUCCESSORS IN INTEREST OR ANY BENEFICIARY OR ASSIGNEE OF THIS CONTRACT FOR ANY CONSEQUENTIAL, INCIDENTAL, INDIRECT, SPECIAL OR PUNITIVE DAMAGES ARISING OUT OF THIS CONTRACT OR ANY BREACH THEREOF, OR ANY DEFECT IN, OR FAILURE OF, OR MALFUNCTION OF THE EQUIPMENT HEREUNDER, WHETHER BASED UPON LOSS OF USE, LOST PROFITS OR REVENUE, INTEREST, LOST GOODWILL, WORK STOPPAGE, IMPAIRMENT OF OTHER GOODS, LOSS BY REASON OF SHUTDOWN OR NON-OPERATION, INCREASED EXPENSES OF OPERATION, COST OF PURCHASE OF REPLACEMENT POWER OR CLAIMS OF PURCHASER OR CUSTOMERS OF PURCHASER FOR SERVICE INTERRUPTION WHETHER OR NOT SUCH LOSS OR DAMAGE IS BASED ON CONTRACT, WARRANTY, NEGLIGENCE, INDEMNITY, STRICT LIABILITY OR OTHERWISE.

10. Nuclear Liability

In the event that the Equipment sold hereunder is to be used in a nuclear facility, the Purchaser shall, prior to such use, arrange for insurance or governmental indemnity protecting the Company against liability and hereby releases and agrees to indemnify the Company and its suppliers for any nuclear damage, including loss of use, in any manner arising out of a nuclear incident, whether alleged to be due, in whole or in part to the negligence or otherwise of the Company or its suppliers.

11. Governing Law

The rights and obligations of the parties shall be governed by the laws of the State of Delaware excluding any conflicts of law provisions. The United Nations Convention on Contracts for the International Sale of Goods shall not apply to this agreement.

12. Export Control

The Company's products are U.S. origin items and subject to U.S. export control laws, including the Export Administration Regulations. Customer agrees that it will comply with U.S. export control laws and will not export, re-export, transfer, re-transfer, sell, re-sell, otherwise divert Company products contrary to U.S. law. Customer further agrees that it will obtain all required export licenses.

13. Execution

The Company shall not be bound by any contract or any modification thereto until approved in writing by an officer of the Company. The contract, when so approved shall supersede all previous communications, either oral or written.



Terms and Conditions

Part Sales

1. General

The Terms of Conditions outlined herein shall apply to the sales of parts by KMT Waterjet Systems (hereinafter referred to as Company.) No additional or contrary terms shall be binding upon the Company unless agreed to in writing.

2. Schedule Dates and Delays

Schedule dates are approximate and neither party shall be liable for loss, damage, detention, or delay due to war, riots, civil or military authority including governmental laws, orders, priorities or regulations, acts of the other party, embargo, car shortage, wrecks or delay in transportation, inability to obtain necessary labor, materials or manufacturing facilities from usual sources, faulty forgings or castings, or other causes beyond the reasonable control of such party.

3. Taxes

The prices provided for herein do not include any present or future Federal, State, Municipal sales, use, excise, gross receipts, property, or other similar type tax with respect to any material or equipment covered hereby. If the Company is required by applicable law or regulation to pay or collect any such type tax or taxes on account of this transaction or the material or equipment covered hereby, then such amount of tax shall be paid by the Purchaser in addition to the prices herein provided for.

4. Warranty and Shipping

The Company warrants that parts manufactured by it will be as specified and will be free from defects in materials and workmanship. The Company's liability under this warranty shall be limited to the repair or replacement of any part, and the Company shall pay for standard shipping costs of any such replacement part to the Purchaser's place of business via UPS Ground, provided the Purchaser notifies the Company in writing of any such defect promptly upon discovery, but in no event later than six (6) months from the date of shipment of such part by the Company. Should the Purchaser request special shipping instruction such as exclusive use of shipping facilities, including air freight when common carrier has been quoted and before a change to the order is received by the Company, the additional charges will be honored by Purchaser.

Warranties applicable to material and equipment supplied by the Company but wholly manufactured by others shall be limited to the warranties extended to the Company by the manufacturer which are able to be conveyed to the Purchaser.

The Company makes no performance warranty and the effects of corrosion, erosion and normal wear and tear are specifically excluded from the Company's warranty.

THE COMPANY MAKES NO OTHER WARRANTY OR REPRESENTATION OF ANY KIND WHATSOEVER, EXPRESSED OR IMPLIED, EXCEPT THAT OF TITLE, AND ALL IMPLIED WARRANTIES, INCLUDING ANY WARRANTY OF MERCHANTABILITY AND FITNESS FOR A PARTICULAR PURPOSE, ARE HEREBY DISCLAIMED.

5. Limitation of Liability

The remedies of the Purchaser set forth herein are exclusive, and the liability of the Company with respect to this order shall not exceed the purchase price of the part upon which such liability is based.

The Company and its suppliers shall in no event be liable to the Purchaser, any successors in interest or any beneficiary of this order for any consequential, incidental, indirect, special or punitive damages arising out of this order or any breach thereof, whether based upon loss of use, lost profits or revenue interest, lost goodwill, work stoppage, impairment of other goods, loss by reason of shutdown or non-operation, increased expenses of operation, cost of purchase of replacement power or claims of Purchaser or customers of Purchaser for service interruption, whether or not such loss or damage is based on contract, warranty, negligence, indemnity, strict liability or otherwise.

6. Nuclear Liability

In the event that the parts sold hereunder are to be used in a nuclear facility the Purchaser shall, prior to such use, arrange for insurance or governmental indemnity, protecting the Company against liability and hereby suppliers for any nuclear damage, including loss of use, in any manner arising out of a nuclear incident, whether alleged to be due in whole or in part to the negligence or otherwise of the Company or its suppliers.

7. Export Control

The Company's products are U.S. origin items and subject to U.S. export control laws, including the Export Administration Regulations. Customer agrees that it will comply with U.S. export control laws and will not export, re-export, transfer, re-transfer, sell, re-sell, otherwise divert Company products contrary to U.S. law. Customer further agrees that it will obtain all required export licenses.



Terms LD-146 Domestic Service Supervisor

When KMT Waterjet Systems (hereinafter called the Company) provides the Services of a Service Supervisor (hereinafter called the Supervisor) to consult with and advise the Purchaser in the installation, starting up and/or overhaul or maintenance of equipment of KMT Waterjet manufacture, such Supervisor shall not be responsible for the procurement of labor or mechanical work performed by others. The Service Supervisor's services shall be furnished under the following conditions:

1. All necessary workmen (common, semi-skilled and skilled), together with proper labor supervision shall be furnished by the Purchaser, at his expense. Qualified Support labor must be available to the Supervisor at all times during the Supervisor's work hours. **The Supervisor is prohibited by the Company from working alone.**

2. All necessary utilities shall be furnished by the Purchaser, at his expense.

3. The Supervisor will expect to work consecutive days until the contracted work is complete. For any day the Supervisor is available for work and is denied access, with the exception of national holidays, the Purchaser will be invoiced by the Company for eight (8) hours at the KMT rate in effect at the time of service, plus associated living expenses.

4. The Purchaser shall provide all tools and equipment required for any installation or service work. The Company's Supervisor may bring with him, or ship to the jobsite, special tools which are and shall remain Company property. If such tools are too heavy for transport by the Supervisor, the Purchaser shall assist in arranging for their return to a location designated by the Company at the completion of the services.

5. The Company shall be reimbursed by the purchaser for all transportation costs for any required special tools or equipment, plus replacement costs for any of these items which are not returned to the Company at the completion of the services.

6. The Company agrees that the Supervisor will provide Best Efforts in effecting repairs to equipment supplied by the Company, but provides no guarantee that such Best Efforts will result in restoration of proper operation of equipment the Supervisor is contracted to repair.

7. The Supervisor shall be suitably covered with insurance in the areas of Worker's Compensation, Public Liability and Automobile Insurance where the use of a vehicle is required. Certificates confirming this insurance coverage are obtainable upon request. The Company shall in no event be liable for any loss recoverable by the Purchaser under insurance policies covering Purchaser's property.

8. The Company accepts no responsibility for material or the acts of men furnished by the Purchaser. The Company is not responsible for the rate of progress or the date of completion of the work nor for incorrect operation or damage incurred due to improper storage or handling.

9. The Company shall be permitted to assign all or any portion of its performance under this Contract to a selected Professional Service organization, without the prior consent of the Purchaser.

10. The Company and its affiliates or suppliers shall in no event be liable to the Purchaser, any successors in interest or any beneficiary of this Contract for any consequential, incidental, indirect, special or punitive damages arising out of this Contract or any breach thereof, or any defect in, or failure of equipment or machinery, whether based upon loss of use, lost profits or revenue, interest, lost good will, work stoppage, impairment of other goods, loss by reason of shutdown or non-operation, increased expenses of operation, cost of purchase of replacement power or claims of Purchaser or customers of Purchaser for service interruption, whether or not such loss or damage is based on contract, warranty, negligence, indemnity, strict liability, or otherwise. **The total liability of the Company under this Contract in all other respects shall be limited to the purchase price of the services furnished hereunder.**



Terms LD-147 International Service Supervisor

When KMT Waterjet Systems (hereinafter called the Company) provides the Services of a Service Supervisor (hereinafter called the Supervisor) to consult with and advise the Purchaser in the installation, starting up and/or overhaul or maintenance of equipment of KMT Waterjet manufacture, such Supervisor shall not be responsible for the procurement of labor or mechanical work performed by others. The Service Supervisor's services shall be furnished under the following conditions:

1. The Purchaser shall pay the Company for the services of said Supervisor per company service rates and terms in effect at the time the contracted work is complete. Any day the Supervisor is available for work and is denied access, with the exception of national holidays, will be invoiced eight (8) hours at the company service rate in effect on that day plus associated living expenses.

2. The Company shall also be reimbursed by the Purchaser for: (a) The Supervisor's transportation expenses en-route from the Company's facility or equivalent starting point to the jobsite and return thereto; (b) Any processing costs for passports, inoculations, etc., necessarily incurred in preparation for travel, as well as entry or exit fees, required to be paid as a result of such travel; (c) Subsistence and quarters for the Supervisor, comparable to those furnished the Purchaser's Superintendent. In the event the Purchaser shall decide to provide living accommodations to the Supervisor, such accommodations shall be equal to those provided for the Purchaser's Superintendent and shall not be less than the maximum accommodations furnished supervisory personnel of other contractors at Purchaser's jobsite; (d) Local transportation costs to and from the jobsite (taxi, auto rental, etc.); (e) All living expenses as detailed in (c) and (d) above for days where the supervisor has been denied access; (f) Transportation costs for any required special tools or equipment, plus costs for any of these items which are not returned to the Company at the completion of the services.

3. In the event that the Supervisor of the Company becomes obligated to pay any local taxes, levies, imposts, social charges, withholdings or duties of any nature, (hereinafter collectively called Taxes) as a result of services rendered herein, the Purchaser shall assume and pay such Taxes directly to the local tax authorities, or alternatively, immediately reimburse the Company for such Taxes, together with an amount which takes into account any Taxes due on account of a reimbursement including any taxes thereon. Purchaser shall pay any tax penalties or late charges which may be due in connection therewith. In the event the Purchaser pays such Taxes directly to the local tax authorities, it shall immediately furnish the Company with appropriate receipts evidencing such payment.

4. All necessary workmen (common, semi-skilled and skilled), together with proper labor supervision shall be furnished by the Purchaser, at his expense. All necessary utilities shall also be furnished by the Purchaser, at his expense. Qualified support labor must be made available to the Supervisor at all times during the Supervisor's work hours. **The Supervisor is prohibited by the Company from working alone.**

5. The Purchaser shall provide all tools and equipment required for any installation or service work. The Company's Supervisor may bring with him, or ship to the jobsite, special tools which are and shall remain Company property. If such tools are too heavy for transport by the Supervisor, the Purchaser shall assist in arranging for their return to a location designated by the Company at the completion of the services.

6. The Purchaser shall provide suitable office facilities convenient to the jobsite for work assignments exceeding thirty (30) days; facilities to include heat, light, desk, chair, telephone, and safe storage space for drawings and tools.

7. The Supervisor shall be properly covered with insurance in the areas of Worker's Compensation, Public Liability and Automobile Insurance where the use of a vehicle is required. Certificates confirming this insurance coverage are obtainable upon request. The Company shall in no event be liable for any loss recoverable by the Purchaser under insurance policies covering Purchaser's property.

8. The Company agrees that the Service Supervisor will provide Best Efforts in effecting repairs to equipment supplied by the Company, but provides no guarantee that such Best Efforts will result in restoration of proper operation of equipment the Service Supervisor is contracted to repair.

9. The Company accepts no responsibility for material or the acts of men furnished by the Purchaser. The Company is not responsible for the rate of progress or the date of completion of the work nor for incorrect operation or damage incurred due to improper storage or handling.

10. The Company shall be permitted to assign all or any portion of this Contract to a selected Professional Service organization without the prior consent of the Purchaser.

11. The Company reserves the right to replace a Service Supervisor after a 30 day period, in which event the Purchaser will pay to the Company associated expenses for the Supervisor's return trip. The replacement Supervisor will be furnished on the same basis as outlined herein.

12. If the services of a Supervisor are required for a period longer than six (6) months and the Company authorizes such Supervisor to be accompanied by members of his immediate family, the Purchaser will pay the Company for round trip expenses in connection with travel between the jobsite and the respective normal place of residence of such members of the immediate family of the Supervisor.

13. The Purchaser agrees that it will render all assistance to insure the Supervisor will be permitted prompt and safe exit from the country in which the services are performed.

14. The Company shall not be bound by or required to adhere to any term or provision of a purchase order, quotation, bid, letter of credit, or like document, or any provision of law, regulation or custom, which would cause the Company or any of its parents or affiliates to be in violation of the export laws, taxing statutes or regulations of the country of citizenship of the Supervisor or other country having jurisdiction over this contract.

15. The Company and its affiliates or suppliers shall in no event be liable to the Purchaser, any successors in interest or any beneficiary of this Contract for any consequential, incidental, indirect, special or punitive damages arising out of this Contract or any breach thereof, or any defect in, or failure of equipment or machinery, whether based upon loss of use, lost profits or revenue, interest, lost goodwill, work stoppage, impairment of other goods, loss by reason of shutdown or non-operation, increased expenses of operation, cost of purchase of replacement power or claims of Purchaser or customers of Purchaser for service interruption, whether or not such loss or damage is based on contract, warranty, negligence, indemnity, strict liability, or otherwise. **The total liability of the Company under this Contract in all other respects shall be limited to the purchase price of the services furnished hereunder.**



SECTION 2

INSTALLATION

2.1 Overview

Installation and commissioning requirements and procedures are detailed in this section. These procedures require a thorough understanding of the individual components and systems, safety issues, and the overall operation of the intensifier.

All personnel involved in the installation, operation and/or service of the intensifier must carefully review this manual prior to installing and commissioning the machine.

The Technical Service Department at KMT Waterjet Systems is available to assist in the installation and commissioning process. Service and repair training for maintenance personnel is also available.

2.2 Installation Summary

The following summary lists the procedures required for the installation and commissioning of the intensifier system. Details and requirements for each item are discussed in this section.

- Upon receipt, the machine must be uncrated and moved into position on a level surface.
- Properly sized power drops with fused disconnects must be installed.
- A pneumatic drop with a manual shutoff valve and regulator for the air connection must be installed.
- Plumbing and manual shutoff valves for the inlet and outlet cooling water (oil-to-water models), and the inlet and outlet cutting water must be installed.

Incoming source water must meet specific water quality standards, flow rates and pressure requirements. It may be necessary to install water conditioning and/or pressure boosting equipment to meet these water purity and pressure requirements.

- Drain water plumbing must be suitably located and installed for the proper disposal of wastewater.
- High pressure tubing runs from the intensifier to the cutting station must be installed with the appropriate mountings, support brackets and hardware.
- Wiring must be installed and connected between the intensifier and the cutting station control system.
- The machine must be commissioned and tested.

2.3 Site Requirements

The intensifier must be installed indoors where air borne dust and contaminants are minimal. The ambient temperature should be between 40° F (5° C) and 104° F (40° C), with a maximum relative humidity of 95%.

Refer to Table 2-1, Equipment Dimensions and Weight, to establish a suitable installation site. A minimum clearance of 36 inches (914 mm) should be provided on all sides of the machine to facilitate service.

Figure 2-1: Equipment Dimensions

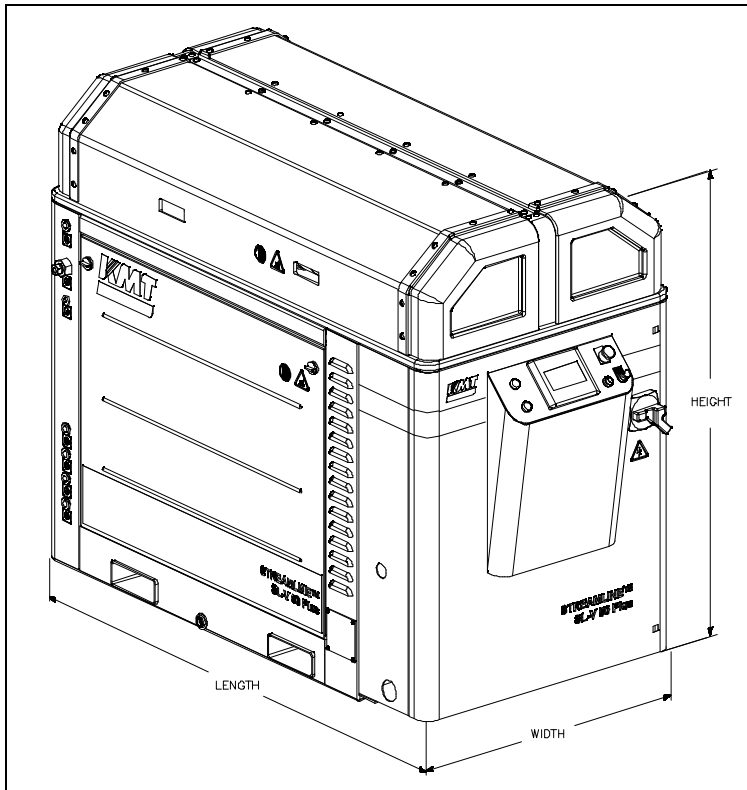

**Table 2-1
Equipment Dimensions and Weight**

Horsepower	Length	Width	Height	Weight
30 HP	67.98" (1,727 mm)	36.00" (914 mm)	57.19" (1,453 mm)	1,920 lbs (870 kg)
50 HP	67.98" (1,727 mm)	36.00" (914 mm)	57.19" (1,453 mm)	2,720 lbs (1,234 kg)
60 HP	67.98" (1,727 mm)	36.00" (914 mm)	57.19" (1,453 mm)	3,220 lbs (1,460 kg)
75 HP	77.75" (1,975 mm)	36.00" (914 mm)	57.19" (1,453 mm)	3,800 lbs (1,724 kg)
100 HP	77.75" (1,975 mm)	36.00" (914 mm)	57.19" (1,453 mm)	4,200 lbs (1,905 kg)
100D	77.75" (1,975 mm)	36.00" (914 mm)	57.19" (1,453 mm)	4,300 lbs (1,950 kg)

**Table 2-1
Equipment Dimensions and Weight**

Horsepower	Length	Width	Height	Weight
Redundant Models (same dimensions as above)				
30 HP				2,200 lbs (998 kg)
50 HP				3,000 lbs (1,360 kg)
60 HP				3,500 lbs (1,588 kg)
75 HP				4,200 lbs (1,905 kg)
100 HP				4,600 lbs (2,087 kg)

Transporting

The weight of the machine is not evenly distributed from one end to the other, particularly on the larger horsepower models. Do not attempt to lift the machine from either end. Note the warnings stamped on the crate. The center of gravity is clearly identified on the sides of the crate. The forklift should be positioned accordingly.

When the machine has been removed from the crate, note the position of the fork pockets on the bottom of the machine. The pockets are positioned in relationship to the center of gravity to balance the weight on the forklift.

Figure 2-2: Fork Pockets

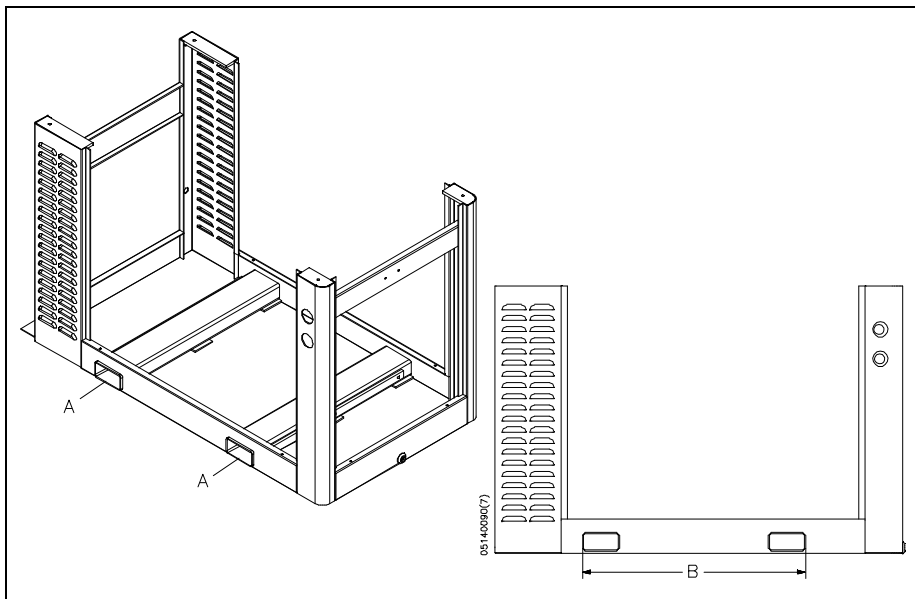

**Table 2-2
Fork Pockets**

A	Fork Pocket Dimensions	
	Height	3.0" (76.2 mm)
	Width	8.0" (203.2 mm)
	Length	36.75" (933.45 mm)
B	Distance Between Pockets	36.0" (914.4 mm)

If the machine will be installed in an overhead location, a forklift or crane can be used to position the pump. Heavy straps or chains, properly rated for the weight requirements, should be placed through each fork pocket, and wrapped around the sides of the machine so they meet on the top. The straps can then be attached to a crane or forklift to lift the machine.



The machine **must** be lifted from the bottom. **Do not** attempt to lift the machine from the intensifier.

2.4 Power Requirements

Power supplied to the pump and wiring for remote control must comply with local, regional and national electrical codes. Service voltage and ampacity must meet the requirements of the specific model. Voltage fluctuations in excess of +/- 10 percent of nominal voltage may damage the machine and void the warranty. Refer to Table 2-3, Ampacity and Power Voltage Requirements.

**Table 2-3
Ampacity and Power Voltage Requirements**

Power Voltage	Motor Horsepower	Full Load Amps	Circuit Breaker Amps
208/3/60	30	80	125
230/3/60	30	76	100
400/3/50	30	43	60
415/3/50	30	43	60
460/3/60	30	38	50
575/3/60	30	32	40
200/3/50-60	50	132	175
200/3/50-60	50	132	175
208/3/50-60	50	128	175

**Table 2-3
Ampacity and Power Voltage Requirements**

Power Voltage	Motor Horsepower	Full Load Amps	Circuit Breaker Amps
230/3/60	50	116	150
380/3/50	50	69	100
400/3/50	50	66	100
415/3/50	50	64	100
460/3/60	50	58	80
575/3/60	50	52	70
230/3/60	60	140	175
380/3/60	60	86	125
460/3/60	60	70	90
200/3/50	75	196	250
230/3/60	75	172	250
400/3/50	75	98	125
460/3/60	75	86	125
200/3/50-60	100	248	350
200-208/3/50-60	100	248/242	350
230/3/60	100	218	300
400/3/50	100	124	175
415/3/50	100	121	175
460/3/60	100	109	175
575/3/60	100	99	125

2.5 Service Connections

The intensifier requires two incoming water sources, cooling water and cutting water; two drain lines, cooling water and wastewater; a high pressure discharge line, and an air supply line. All piping must comply with local, regional and national codes.



Thoroughly purge all supply plumbing prior to connection to remove any residue that could contaminate the system.

All service connections are made on the rear bulkhead of the machine as shown in Figure 2-3, Service Connections. Table 2-4 lists the fittings required and the height of each interface connection.

With the exception of the wastewater and contaminated waste drain lines, manual shutoff valves should be installed for all connections. To facilitate service, the valves should be located as close as practical to the interface connection.

Figure 2-3: Service Connections

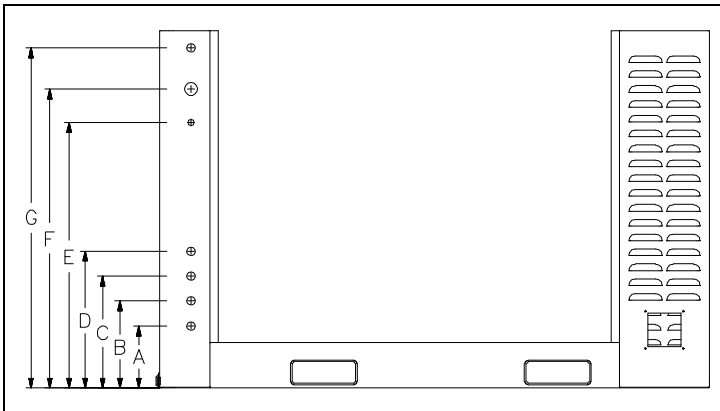

Table 2-4
Service Connections

		Connection	Height
A	Drain	1/2" NPT	7.50" (191 mm)
B	Cutting Water In	1/2" NPT	10.50" (267 mm)
C	Cooling Water In (oil-to-water models)	1/2" NPT	13.50" (343 mm)
	Hydraulic Oil In (air-to-water models)	3/4" JIC	
D	Cooling Water Out (oil-to-water models)	1/2" NPT	16.50" (419 mm)
	Hydraulic Oil Out (air-to-water models)	3/4" JIC	
E	Plant Air In	1/4" NPT	32.00" (813 mm)
F	Cutting Water Out	9/16" HP	36.00" (914 mm)
G	Contaminated Waste Drain	1/2" NPT	41.00" (1,041 mm)

Cooling Water (Oil-to-Water Models)

Inlet cooling water flows through the oil-to-water heat exchanger in the hydraulic system to control heat build-up in the hydraulic oil. The cooling water is then discharged through the cooling water out port to either the drain or routed to a customer supplied water chiller.

Cooling water supply piping must be sized to meet the flow and pressure requirements of the specific equipment. If municipal or well water is used for cooling, ensure the supply flow and pressure meet the requirements in Table 2-7, Service Connection Specifications.



If a facility-wide chilled water system is used for cooling, ensure there is a minimum of 35 psi (2.4 bar) pressure differential between the facility supply and discharge plumbing. Installation of an in-line pressure boosting pump may be necessary to provide adequate cooling flow. Dedicated chilled water systems should be sized according to pump horsepower as illustrated in Table 2-5, Chilled Water Systems.

Table 2-5
Chilled Water Systems
Cooling Requirements at Full Capacity

Horsepower	BTU/HR
30	13,400
50	22,000
60	26,800
75	33,500
100	45,000

Note: Coolant flow to the heat exchanger is regulated by the temperature of the contents in the hydraulic reservoir and will be shut off at times.

Cutting Water

Inlet cutting water is filtered and routed to the intensifier where it is pressurized and delivered to the cutting head. The cutting water supply must meet the minimum water quality standards outlined in Section 11, Specifications. Poor water quality will drastically shorten component life and void the warranty.

Cutting water supply piping must be sized to meet the flow and pressure requirements listed in Table 2-7. Only PVC, copper or rubber hoses should be used between the cutting water source and the machine.

The inlet water must be maintained at a minimum pressure of 35 psi (2.4 bar) at all times. If the facility water pressure is below, or can fall below 35 psi (2.4 bar), a water pressure booster pump is required.

NOTE

The machine will not start if inlet cutting water pressure is below 30 psi (2 bar).

Drain

Cutting water released through the safety dump valve when the emergency stop button is initiated is discharged from the drain port. The discharge is considered wastewater and must be piped to an appropriate location, i.e. a sewer line. The volume of water released will be minimal and does not require high pressure plumbing; however, piping must comply with local, regional and national codes.



Plant Air

The facility compressed air connection should provide clean, dry air regulated to 85 psi (5.9 bar). Air usage is minimal, normally less than 1 scf/m.

The following table provides specifications for each ISO air quality classification. KMT recommends adherence to Quality Class 4.

Table 2-6
ISO Air Quality Classifications

ISO Quality Class	Maximum Particle Size (microns)	Maximum Pressure Dew Point (water @ 100 psi)	Maximum Oil Content (Mg/m ³)
1	0.1	-94° F (-60° C)	0.01
2	1	-40° F (-40° C)	0.1
3	5	-4° F (-20° C)	1
4	15	+38° F (+3° C)	5
5	40	+45° F (+7° C)	25
6	--	+50° F (+10° C)	--

Contaminated Waste Drain

Oil and water that can accumulate on the top pan is disposed of through the contaminated waste drain. This oil and water mixture is considered contaminated and disposal must comply with local, regional and national codes. The volume of waste will be minimal and can be collected in a container of some appropriate type.

Table 2-7
Service Connection Specifications

	30 HP	50 HP	60 HP	75 HP	100 HP	100D
Cooling Water (oil-to-water models)						
Maximum consumption at 75° F (24° C) [gpm (L/min)]	2.5 (9.5)	3.0 (11.4)	3.5 (13.2)	4.0 (15.1)	4.5 (17.0)	4.5 (17.0)
Cutting Water						
Maximum consumption [gpm (L/min)]	2.5 (9.5)	4.0 (15.1)	4.5 (17.0)	6.0 (22.7)	8.0 (30.0)	8.0 (30.0)
Minimum inlet cooling water pressure	35 psi (2.4 bar)					
Minimum inlet cutting water pressure	35 psi (2.4 bar) flowing					
Minimum compressed air pressure	85 psi (5.9 bar)					

2.6 Flow Requirements

Figure 2-4, Pressure Drop Values, illustrates the pressure drop for four different pipe sizes. The graph can be used to calculate the minimum source water pressure.

1. Enter the graph at the required GPM and note the pressure drop figures for the different pipe sizes.
2. Multiply the pressure drop (PSI/FT) by the length in feet of each pipe size used from the water source to the intensifier. Add the values together for a total pressure drop value.
3. Add 30 to the total pressure drop to determine the minimum flowing, source water pressure required to provide adequate supply to the intensifier.

Cutting water and cooling water capacity should be calculated separately. Note that the cutting water requirements represent instantaneous, not average, demand. **The machine will not start if the inlet cutting water pressure drops below 30 psi (2 bar).**

Figure 2-4: Pressure Drop Values

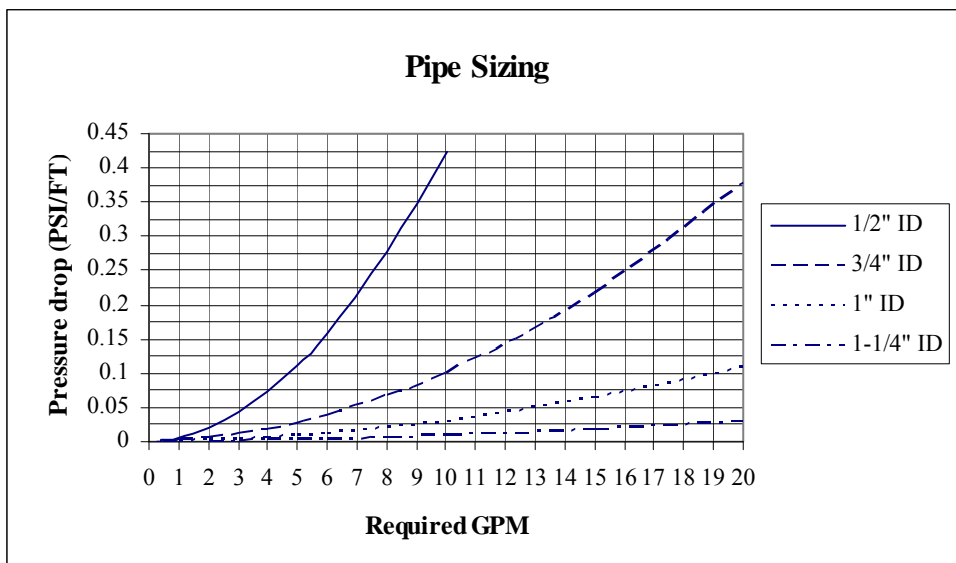

2.7 High Pressure Piping

High pressure piping is used to transport high pressure cutting water from the machine to the cutting station. High pressure piping and fittings must be properly rated and sized. When transporting high pressure water over long distances, tubing and fittings with an outside diameter of 9/16-inch are recommended. The large tubing size reduces vibration, strain and motion; as well as reducing pressure drop and pulsation.



High pressure tubing and fittings must be rated for 60,000 psi (4,136 bar). Failure to use properly rated components may result in component failure causing equipment damage, personal injury or death.

High pressure tubing lengths must be coned and threaded prior to installation. KMT Waterjet provides both hand and power tools for coning and threading high pressure tubing. Tool descriptions and part numbers are provided in Table 2-8.

Table 2-8
Coning and Threading Tools

	Part Number	
	Hand Tools	Power Tools
1/4" Coning Tool	05108832	05109897
3/8" Coning Tool	05108857	05109889
9/16" Coning Tool	05108840	05109871
1/4" Threading Tool	05108865	05122742
3/8" Threading Tool	05108873	05120258
9/16" Threading Tool	05108881	05122759
1/4" Tube Vise	05108782	
3/8" Tube Vise	05108790	
9/16" Tube Vise	05108774	

Measurements and Dimensions

Tubing must be cut to the proper length, both ends of the tubing must then be coned, threaded and deburred.

To determine the tube length, measure the distance between the fittings, and add two times the engagement allowance shown in Table 2-9. Table 2-10 lists the required cone and thread dimensions illustrated in Figure 2-6.

Figure 2-5: Tube Length

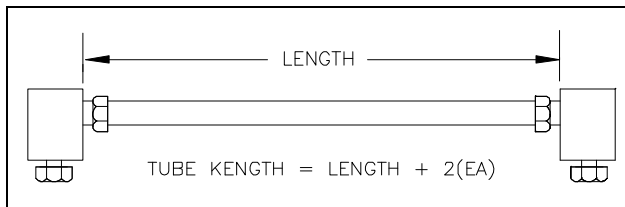
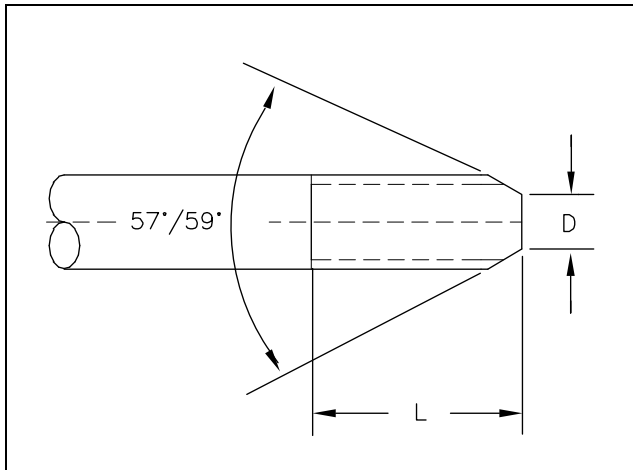

Table 2-9
Engagement Allowance (EA)

1/4" Tubing	0.49" (12.4 mm)
3/8" Tubing	0.68" (17.3 mm)
9/16" Tubing	0.86" (21.8 mm)

Figure 2-6: Cone and Thread Dimensions

Hand Coning

1. Place the body of the coning tool in a vise allowing adequate clearance for the rotation of the cutter handle. Position the tool so the cutter handle is elevated slightly so the lubricant will flow to the cutting blade.

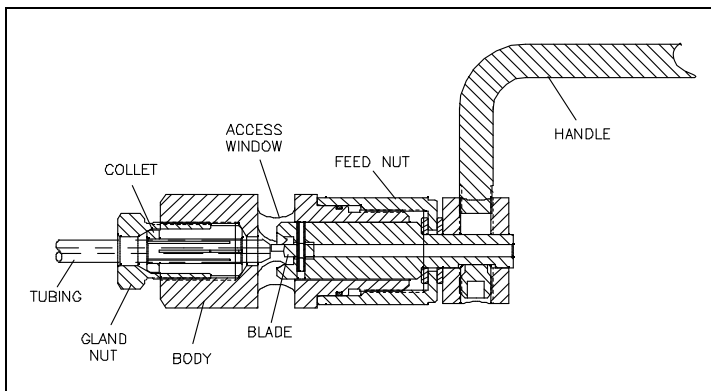
Figure 2-7: Hand Coning Tool

2. Turn the feed nut counter-clockwise to retract the cutting blade past the access window.
3. Loosen the gland nut and insert the tubing through the collet. The end of the tubing should just make contact with the cutting blade. Loosely tighten the gland nut to slightly grip the tubing.
4. Turn the feed nut counter-clockwise 1/4 turn to retract the cutting blade away from the tubing, and tighten the gland nut with a wrench.
5. Apply a liberal amount of cutting oil to the exposed end of the tubing, the cutting blade and through the lubrication channel at the cutter handle.
6. Apply cutting oil frequently and liberally throughout the cutting operation. A medium weight cutting oil with high sulfur content is recommended.
7. Turn the feed nut clockwise until the cutting blade contacts the end of the tubing.

8. In a smooth, continuous motion, turn the cutter handle in a clockwise direction. Simultaneously turn the feed nut in a clockwise direction to establish a constant feed. Do not remove too much material at once; the cutting blade should make light, uninterrupted cuts.

NOTE

Before interrupting the cut, back the cutter blade away from the tubing. Use compressed air or a small brush to remove the accumulation of chips from the blade and the tubing throughout the coning operation.

9. Continue the operation until the feed nut bottoms on the housing. Turn the cutter handle several more rotations to face-off the end of the cone.
10. Retract the cutter blade, loosen the gland nut and remove the tubing. Inspect the cone for surface finish and completeness.

NOTE

Clean the machining chips from the blade and from the collet before coning the next tube.

Power Coning

1. Secure the tubing in a tube vise. No more than the recommended length of tubing should extend beyond the face of the vice. See Table 2-11, Recommended Extension Length.
2. Mount the coning tool in a 3/8-inch or 1/2-inch, variable speed power drill. Apply cutting oil to the end of the tube and slide the coning tool on the tubing.
3. Apply steady pressure against the end of the tubing while the cone is being cut.
4. Apply cutting oil frequently and liberally throughout the cutting operation. A medium weight cutting oil with high sulfur content is recommended.
5. The tool will stop cutting when the tube angle and facing is complete.

NOTE

Clean the machining chips from the blade and body of the tool before coning the next tube.

Table 2-10
Recommended Extension Length

1/4" Tubing	1.25-1.50" (31.8-38.1 mm)
3/8" Tubing	1.25-1.50" (31.8-38.1 mm)
9/16" Tubing	1.75-2.00" (44.5-50.8 mm)

Hand Threading

1. Secure the coned tubing in a tube vise. No more than the recommended length of tubing should extend beyond the face of the vice. See Table 2-11, Recommended Extension Length.
2. Apply cutting oil to the end of the tube and slide the threading tool on the tubing.
3. Grip the handle of the tool firmly, apply steady pressure and turn the tool counter-clockwise. Approximately every half turn, reverse direction to break off and remove the chips.
4. Apply cutting oil frequently and liberally throughout the cutting operation. A medium weight cutting oil with high sulfur content is recommended.
5. Continue threading until the proper thread length is reached, see Table 2-10, Column L. Remove the tool from the end of the tubing.

NOTE

Clean the machining chips from the die and body of the tool before threading the next tube.

Power Threading

1. Secure the coned tubing in a tube vise. No more than the recommended length of tubing should extend beyond the face of the vice. See Table 2-11, Recommended Extension Length.
2. Mount the threading tool in a 3/8-inch or 1/2-inch, variable speed power drill. Apply cutting oil to the end of the tube and slide the threading tool on the tubing.
3. Make sure the drill is set to turn counter-clockwise. Apply steady pressure against the end of the tubing while the threads are being cut.
4. Apply cutting oil frequently and liberally throughout the cutting operation. A medium weight cutting oil with high sulfur content is recommended.
5. Continue threading until the proper thread length is reached, see Table 2-10, Column L. Reverse the direction of the drill and remove the threading tool.

NOTE

Clean the machining chips from the die and body of the tool before threading the next tube.

2.8 High Pressure Connections

When installing high pressure discharge piping it is essential that all burrs are carefully removed and the tubing sections purged with clean compressed air prior to assembly. Lightly spraying the inside of the tube with a carrier fluid, such as WD-40, before purging with air will help carry the burrs.

High pressure piping must be installed without torsional or bending stresses and proper supports and guides must be provided. Torsional stress will cause premature component failure.

Pure Goop anti-seize compound must be applied to the threads and contact surfaces of all stainless steel components prior to assembly. Failure to lubricate components with Pure Goop will result in galling, rendering the components useless.



Do not use any other anti-seize compound. Apply Pure Goop **only to stainless steel** components.

Standard Connections

Standard connections are used for general applications where internal pressure is the only load on the tubing.

Figure 2-8: Standard High Pressure Connections

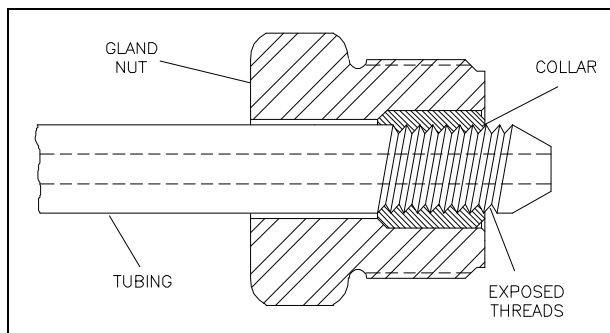

1. Deburr the tubing ID and thoroughly clean the tubing threads.
2. Slip the gland nut onto the tubing.
3. Apply Pure Goop to the threads on the tubing. Screw the collar onto the threaded end of the tubing leaving 1-1/2 to 2-1/2 threads exposed on the tubing between the collar and the coned tubing.

4. Apply Pure Goop to the male threads on the gland nut and insert the tubing into the connection. Engage the gland nut and tighten finger tight.
5. Tighten the gland nut to the torque specifications in Table 2-12.



Proper piping supports and guides must be provided. End connections will not support the tubing load alone.

Anti-Vibration Connections

The bending stresses resulting from excessive vibration or shock on the threaded area of the tubing can cause premature failure at the back of the thread. When tubing will be subjected to vibration, rotation and movement, anti-vibration connections must be used. The anti-vibration collet gland transfers the stress to the unthreaded section of the tubing, and the gripping action of the collet strengthens the entire assembly.

Figure 2-9: Anti-Vibration Connections

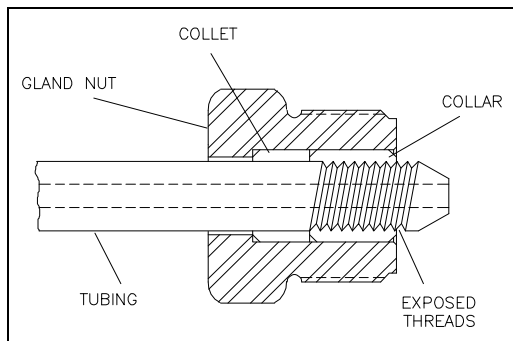

1. Deburr the tubing ID and thoroughly clean the tubing threads.
2. Slip the gland nut and the collet onto the tubing.
3. Apply Pure Goop to the threads on the tubing. Screw the collar onto the threaded end of the tubing leaving 1-1/2 to 2-1/2 threads exposed on the tubing between the collar and the coned tubing.
4. Apply Pure Goop to the male threads on the gland nut and insert the tubing into the connection. Engage the gland nut and tighten finger tight.
5. Tighten the gland nut to the torque specifications in Table 2-12.

When a flexible whip is used to allow cutting nozzle movement, anti-vibration fittings and proper supports and guides must be provided to prevent failures from non-water related stresses. The whip will only flex in a single plane without being subjected to torsional stress. The use of high pressure swivels is strongly recommended.

Table 2-11
Torque Specifications
High Pressure Connections

1/4" Tubing	25 ft-lb (34 Nm)
3/8" Tubing	50 ft-lb (68 Nm)
9/16" Tubing	110 ft-lb (149 Nm)

2.9 Commissioning

When the machine has been positioned, all service connections installed, and the high pressure plumbing has been installed to the cutting area, the machine is ready to be commissioned.

The following procedure is used for the initial startup and testing of the machine.

1. Check all areas in and around the pump for foreign objects and debris. Remove all tools, parts, etc. from the area.
2. Check the hydraulic fluid level. The hydraulic system is pre-filled prior to shipping. If the hydraulic fluid is low or empty due to leakage during transit, the system must be filled. Follow the instructions and specifications in Section 6, Recirculation System.
3. Open the shutoff valves on the service connections and check for leaks.
4. Check the connection between the main power disconnect and the disconnect/circuit break on the enclosure door. Verify the proper voltage supply. Close the enclosure door and turn the control power on.
5. To activate the control panel display, pull the EMERGENCY STOP button out and press the reset button. The control panel will go through a series of diagnostics, and the Run Screen will display. Refer to Section 4, Operation, for additional information regarding control panel functions.

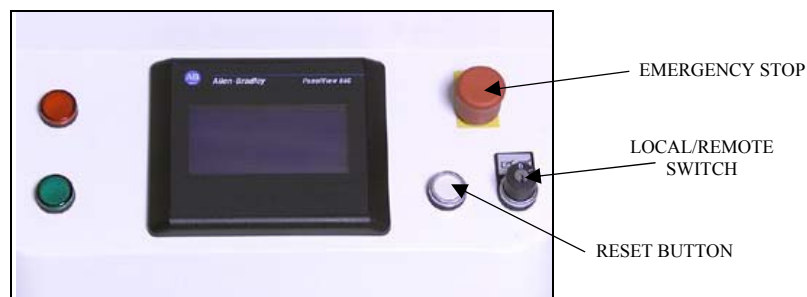

- On the Run Screen, select the ▼ arrow on the PRESSURE switch to select low pressure operation.

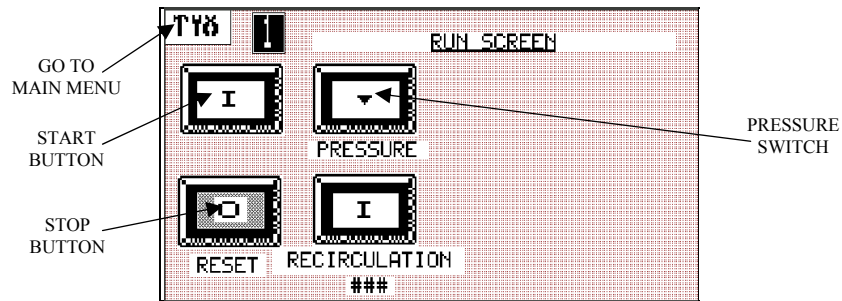

- To avoid a sudden increase in pressure, it is necessary to adjust the high pressure setting. On standard machines, the high pressure adjustment is made at the high pressure control valve on the hydraulic manifold. Refer to Section 7, Hydraulic System, for additional information.

Loosen the locking nut on the high pressure control valve by turning counter-clockwise. Turn the high pressure control valve counter-clockwise, decreasing the pressure to the lowest setting.

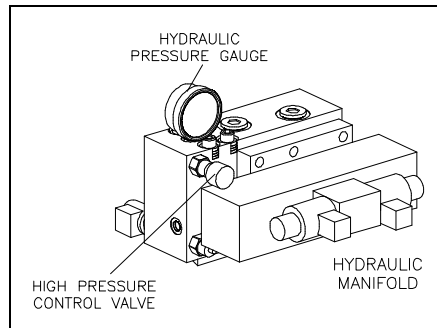

If the machine is equipped with proportional pressure control, the high pressure adjustment is made from the Pressure Control Screen on the control panel. Refer to Section 4, Operation, for additional information.

From the Run Screen, press the tool icon to go to the Main Menu. Select Pressure Control to display the Pressure Control Screen. The dial on the right of the Pressure Control Screen indicates the high pressure setting. Press the ▼ arrow to set the pressure to zero.

Main Menu



Pressure Control Screen

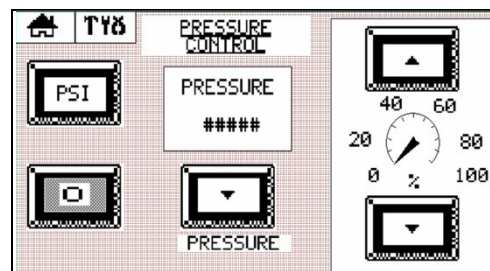

8. Check the motor rotation. Press the START button on the Run Screen and observe the pressure gauge on the hydraulic manifold. If the motor rotation is correct, pressure will begin to build in just a few seconds. If the rotation is not correct, the gauge will not move.

If the motor shaft is rotating in the wrong direction, press the STOP button and turn the control power off by pressing the EMERGENCY STOP button.

The electrical power phase must be reversed to any two motor leads. The leads can be reversed at the disconnect/circuit breaker on the enclosure door, or at the main power disconnect.



Do not allow the motor to run backward. Incorrect motor rotation will result in damage to the hydraulic pump.

9. If the unit is equipped with an oil-to-air heat exchanger, check the fan motor rotation. When viewed from the motor end, the fan should rotate clockwise. If the rotation is not correct, the electrical power phase must be reversed to any two motor leads. The leads can be reversed at the junction box on the fan motor or at the electrical enclosure.
10. Remove the cutting orifice and open the nozzle valve.
11. Activate the control power and press the START button to start the motor. The dump valve will open for a short time to allow trapped air to bleed from the high pressure cylinders. Run the machine in low pressure for approximately five minutes with the orifice removed to purge the system.
12. Check for any leaks in the plumbing, or around the high pressure cylinders. If leaks are detected, stop the machine and correct any problems.
13. Observe the Booster Pressure Gauge on the front of the machine to ensure the inlet cutting water pressure is between 90-120 psi (6-8 bar). If not, the booster pump pressure must be adjusted. Refer to Section 5, Low Pressure Water System, for additional information.

Remove the acorn nut on the side of the booster pump and use a flat blade screwdriver to turn the adjustment screw. Turn the screw clockwise to increase the pressure or counter-clockwise to decrease the pressure.

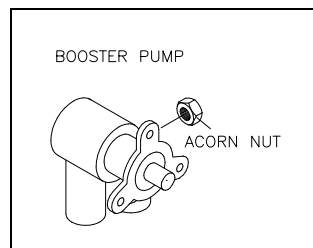

14. Check the safety circuits by pushing the EMERGENCY STOP button in and verifying that the power goes off and high pressure water is drained from the system. If applicable, check all remote start and emergency stop functions.
15. Install a large, inexpensive orifice and start the machine.

16. On the Run Screen, select the ▲ arrow on the PRESSURE switch to select high pressure operation. Increase the high pressure setting in gradual increments, checking for leaks at each interval. Continue increasing the pressure until the operating pressure is reached.

The high pressure setting is increased by turning the high pressure control valve on the hydraulic manifold clockwise, or by pressing the ▲ arrow on the Pressure Control Screen.

NOTE

It is strongly recommended that the high pressure plumbing be purged under high pressure operating conditions, using a large, inexpensive orifice. Contamination can be released when the tubing expands under pressure. Early orifice failures could be experienced if the piping is not adequately purged.

2.10 Decommissioning

All local regulations must be adhered to when the intensifier is decommissioned and taken out of service for any reason.



SECTION 3

MAINTENANCE

3.1 Overview

The entire SL-V series has been designed to fail safely. Systems fail gradually; seals and connections begin to leak slowly or suddenly through specially designed weep holes. Water or oil dripping from a weep hole indicates internal seals or valves are beginning to fail, a warning that maintenance will be required.

The comprehensive fault detection and troubleshooting logic built into the programmable logic controller (PLC) monitors crucial pressure, temperature and fluid levels. Warning and shutdown sensors guard against potential injury and equipment damage.

3.2 Maintenance

The waterjet system has been designed for ease of maintenance and long, reliable operation. In order to keep the equipment in optimum operating condition, routine and preventive maintenance is essential. Detailed maintenance and troubleshooting procedures for specific systems are provided in subsequent sections of this manual.

Daily Inspection

The following inspection procedures should be performed each day. If problems are detected, they should be remedied before placing the machine in service.

- Prior to startup, inspect the area around the machine, the high pressure piping and connections for indications of leaks.
 - Make sure there is no maintenance work in process.
 - Check the hydraulic oil level.
- As the machine is started and water pressure increases, listen for unusual sounds.
 - Check for water or oil leakage.
 - Check the condition of the water filter and the oil filter.

Periodic Maintenance

A number of factors can contribute to component failure; poor water quality, operating conditions, or improper maintenance procedures. Maintaining a service log can be a useful method of tracking component life and maintenance trends. Analyzing service intervals will assist in preparing a preventive maintenance schedule tailored to your specific application and production requirements. Periodic maintenance, at regularly scheduled intervals, will minimize unscheduled downtime and premature component failure.

Improper assembly can lead to the premature failure of components. Maintenance procedures must be followed carefully; components must be properly cleaned prior to assembly and tightened to the correct torque specifications.

- Maintain a clean, dust and dirt free work area for maintenance.
- Use only clean, dry air and clean, filtered solvent when flushing parts.
- Use lint free cloths for cleaning.
- Use extreme care when aligning close tolerance parts for assembly. Do not force the parts together. If parts bind during assembly, they must be disassembled and re-aligned.
- Use only original KMT Waterjet replacement parts for consistent performance and reliability; and to protect equipment warranty.

To avoid unsafe conditions and the risk of equipment damage, operating personnel and service technicians must carefully read and follow the procedures in this manual.

High Pressure System Maintenance

The high pressure system is conveniently mounted on a drip pan. All service components are readily accessible, and can be removed from the unit easily for maintenance and service.

- High pressure fittings, valves and tubing must be rated for 60,000 psi (4,137 bar). Failure to use properly rated components may result in component failure, equipment damage and personal injury.
- Do not over-torque fittings to stop leakage.
- Ensure all components are clean, free of burrs, metal particles, dirt and dust prior to assembly.

After servicing high pressure components the high pressure water system must be thoroughly flushed to remove any debris or contaminants.

1. Operate the intensifier for a short period with the nozzle valve open and the orifice removed.
2. Turn the intensifier off and install an orifice.
3. Turn the machine on and increase the operating pressure in gradual increments. Check all high pressure connections for leaks.

Many components are lubricated prior to assembly. Table 3-1 lists the recommended lubricants and their applications. Substitutions are not recommended.

Table 3-1
Lubrication Specifications

Description	Application	Part Number
Pure Goop, 1 ounce	Stainless steel threads and metal-to-metal joints	10084440
FML-2 Grease, 14-1/2 ounce	O-rings, backup rings, bearing rings, seal components	10087385
JL-M Grease, 16 ounce	Non-stainless steel threads	49832199

3.3 Maintenance Precautions

Make sure all safety devices are operational. Each device should be checked on a specified schedule. If the device does not function, it must be replaced before operating the machine.

Check the EMERGENCY STOP button. The normal operating position is pulled out. Turn the power on and activate the emergency stop button by pushing it in to verify the power goes off and the safety dump valve opens to bleed the high pressure from the system.

Before performing any maintenance on the equipment, take the system out of service and make sure the controls are properly locked and marked. Never perform any maintenance on the equipment without making sure the main control power is locked out in the OFF position.

- **Never** service or maintain the equipment while it is operating.
- Steam or fog inside the top cover is an indication of a high pressure leak. All high pressure leaks must be repaired immediately. Press the EMERGENCY STOP button to turn the control power off and bleed off the high pressure water from the intensifier **before** lifting the cover.
- Never service or maintain any high pressure component, or loosen any high pressure fitting when it is pressurized. Press the EMERGENCY STOP button to turn the control power off and bleed off the high pressure water from the intensifier before servicing.
- If leakage occurs at a sealing surface, high pressure water is released through weep holes. If a pressurized fitting is loosened, a jet of high pressure water will exit the nearest weep hole with **possible hazardous results**.

3.4 Tool Kits

Table 3-2 provides a list of the spare parts and maintenance tools included in standard tool kits for SL-V series pumps. Components can also be ordered individually.

**Table 3-2
Tool Kits**

Part Number	Description	Tool Kit 05072723 7/8" Plunger	Tool Kit 80075930 1-1/8" Plunger
10087385	FM-L Grease, 14-1/2 ounce	1	1
80078330	Seal Removal Tool Stand	1	1
10079986	Strap Wrench	1	1
10081370	Spanner Wrench	1	1
05053871	Combination Wrench, Box/Open	1	1
10084440	Pure Goop, 1 ounce	3	3
10087609	Crescent Wrench	1	1
20484961	Vee Block	1	1
05066139	Cylinder Wrench	1	1
10148674	HP Seal Installation Tool	1	



Table 3-2
Tool Kits

Part Number	Description	Tool Kit 05072723 7/8" Plunger	Tool Kit 80075930 1-1/8" Plunger
05146618	HP Seal Installation Tool		1
10149029	Emery Cloth, 320 Grit	2	2
10149037	Emory Cloth, 400 Grit	4	6
10149045	Emory Cloth, 600 Grit	6	6
10149052	Glass Pane	1	1
20477460	Plunger Removal Tool	1	
20477469	Plunger Removal Tool		1
80078256	Torque Wrench, 5-75 Ft/Lbs	1	1
05103957	Hex Driver, 12MM	1	
20470475	Seal Installation Tool Kit, Pneumatic Valve	1	1
10079523	HP Plug, .38	1	
10078772	HP Plug, .56		1
10078129	HP Gland, .38	1	
10078608	HP Gland, .56		1
80082191	JL-M Grease, 15 milliliter pack	2	2
80079239	End Cap Wrench	1	1
80078249	Socket Wrench, .38	1	1
20487868	Threadlocker 242 Adhesive, .50 milliliter tube	1	1
20494983	Threadlocker Primer, 1-3/4 ounce	1	1
20473684	Hex Socket, .63		1



SECTION 4 OPERATION

4.1 Overview

The SL-V series utilizes a programmable logic controller (PLC) to provide comprehensive fault detection and troubleshooting logic. The operator functions and warnings offer a comprehensive view of operating conditions, impending faults, shutdown faults and suggested remedies.

Remote monitoring of the PLC is available as an option. A modem interface allows KMT Waterjet to access to the machine's PLC program. The KMT Customer Service Department can perform real time diagnostics, remote troubleshooting, data analysis and software updates.

The operator interface is through a touch sensitive control display where operating parameters are set and monitored. Optional proportional pressure control allows the operator to select or vary the operating pressure from the control display or from a remote console. When the machine is equipped with an optional pressure transducer the operating pressure can be viewed from the display. Analog modules for the PLC are required to operate both of these options.

Figure 4-1 identifies the control panel components and functions.

Figure 4-1: Display Panel



4.2 Startup Sequence

The startup sequence varies depending on the previous stop condition, and whether the machine is equipped with the optional pressure transducer.

Startup after Motor Stop

After a normal motor stop the safety dump valve will be closed and high pressure will be present in the intensifier. Press the start button on the Run Screen to start the motor. The machine will be held in low pressure for 5-60 seconds as determined by the operator, it then goes to high pressure or remains in low pressure, depending on the previous pressure setting on the Run Screen.

If the machine is equipped with a pressure transducer and pressure is not allowed to bleed, the startup sequence is the same as above.

If the machine is equipped with a pressure transducer and pressure is allowed to bleed through the orifice to below 1,000 psi (69 bar), the dump valve will open. In this case, the startup sequence is as described below.

Startup after Emergency Stop





After an emergency stop the safety dump valve will be open and high pressure released in the intensifier. The dump valve will close three seconds after the intensifier begins to stroke.

Pull the e-stop button out and push the reset button to activate the control display. Press the start button on the Run Screen to start the motor. The machine will be held in low pressure for for 5-60 seconds as determined by the operator, to allow trapped air to bleed from the high pressure cylinders. It then goes to high pressure or remains in low pressure, depending on the previous pressure setting on the Run Screen.

4.3 Display Controls

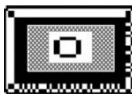
Table 4-1 illustrates controls common to all displays.

Table 4-1
Display Controls

Control	Function	Comments
	START The start button only displays on the Run and Maintenance Screens	The Run Screen is the only location where the machine can be started to create pressure. The machine must be started from the Maintenance Screen to access maintenance functions. The machine will start in recirculation mode.
	STOP The stop button displays on all screens except the Alarm History and Language Screens	Motor stop only, the control power remains on
	Return to Main Menu	
	Return to Run Screen	
	ON position for controls on the Set-Up Screens	Enables function
	OFF position for controls on the Set-Up Screens	Disables function

4.4 Main Menu

The Main Menu provides a list of available setup and monitoring screens. Press the ▲ or ▼ arrow to highlight the desired screen. Press enter (↵) to display the selected screen.

Figure 4-2: Main Menu



4.5 Run Screens

The Run Screen is the only location where the machine can be started to create pressure. After five minutes on any other screen, the display will default to the Run Screen.

Run screens are configured according to equipment options. If machines are connected to a header system that is controlled by the KMT Waterjet Balancing System, a number displays on the top of the Run Screen to indicate the machine's position within the system, as illustrated in Figure 4-3.

Figure 4-3: Run Screen - Standard Machine

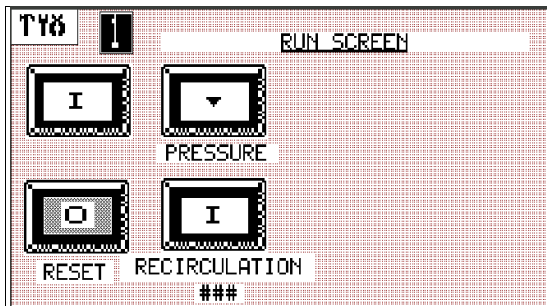

Figure 4-4: Run Screen - Pressure Transducer

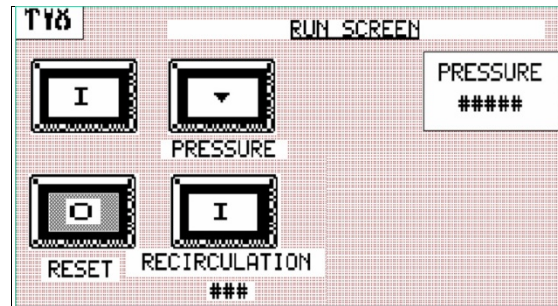

Figure 4-5: Run Screen - Redundant

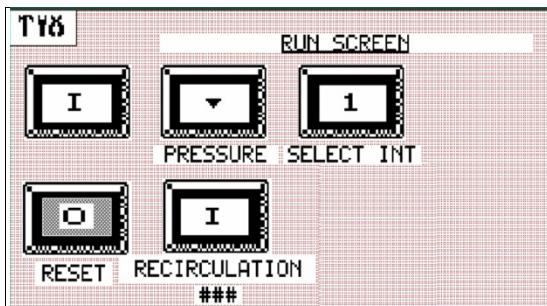
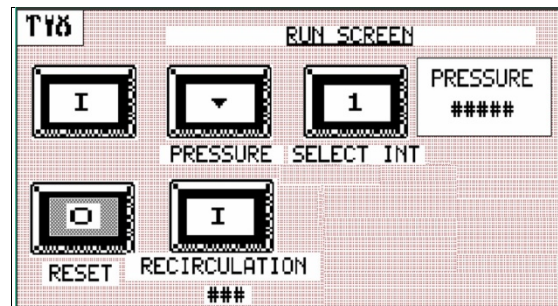

Figure 4-6: Redundant and Pressure Transducer



The Run Screen displays the following functions:

- START button flashes when the machine is ready to start. After the machine has been stopped, there is a five-second delay before startup.
- STOP button flashes to indicate the machine is on and can be stopped by pressing this button
- RESET is the inlet water solenoid indicator. The inlet water solenoid valve is automatically closed five minutes after the machine shuts down. When it flashes, press the STOP button to reset and open the valve. This function can be disabled on the Set-Up Screen
- PRESSURE switch; press the ▲ or ▼ arrow to select high or low pressure. When stopped and restarted the machine will always start in low pressure. After 5-60 seconds, depending on the interval selected by the operator, it will go to high pressure or remain in low pressure, depending on the previous high/low pressure setting.

- RECIRCULATION switch; select the on position to recirculate the machine. The machine will recirculate for 10 minutes before the switch shuts off. Recirculation can be manually stopped by pressing the stop button. Recirculation time is indicated below the switch.

The Run Screen in Figure 4-4 will display if the machine is equipped with a pressure transducer. The PRESSURE indicator displays the output pressure in either psi or bar, depending on the selection made on the Set-Up Screen.

The Run Screen in Figure 4-5 will display if the machine is a redundant model and the REDUNDANT control on the Set-Up Screen is in the ON position. Press the SELECT INT button to activate intensifier one or two.

The Run Screen in Figure 4-6 will display if the machine is redundant and equipped with a pressure transducer. The REDUNDANT and PRESSURE TRANSDUCER controls on the Set-Up Screen should be in the ON position.

4.6 Pressure Control Screen

The Pressure Control Screen displays if the machine is equipped with the optional proportional pressure control. If Pressure Control is selected on the Main Menu and the machine is not equipped with this option, a message screen displays prompting THIS UNIT IS NOT EQUIPPED WITH PROPORTIONAL PRESSURE CONTROL.

Figure 4-7: Pressure Control Screen

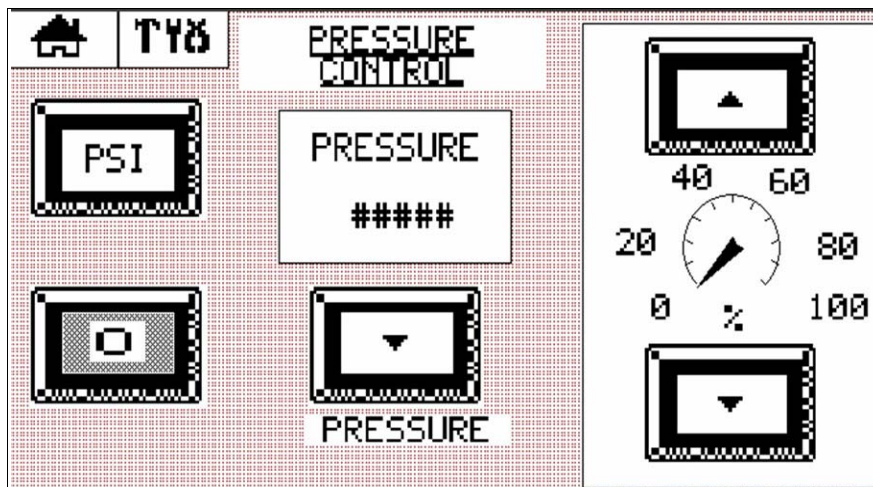

The Pressure Control screen in Figure 4-7 displays the following functions:

- PSI/BAR selector changes the pressure display on the Run Screen and the Pressure Control Screen; press to display output pressure as psi or bar
- STOP button flashes to indicate the machine is on and can be stopped by pressing this button
- PRESSURE indicator displays the output pressure. The PRESSURE indicator will not display if the machine is not equipped with the optional pressure transducer.
- PRESSURE switch; the ▲ or ▼ arrow indicates high or low pressure
- PROPORTIONAL PRESSURE CONTROL; increment/decrement pressure allows the pressure to be set in 1% increments; press the ▲ or ▼ arrow to set the pressure from 0 to 100%

4.7 Setup Screens

Setup screens are configured for the specific machine, displaying only the available functions.

Figure 4-8: Setup Screen - Standard Units

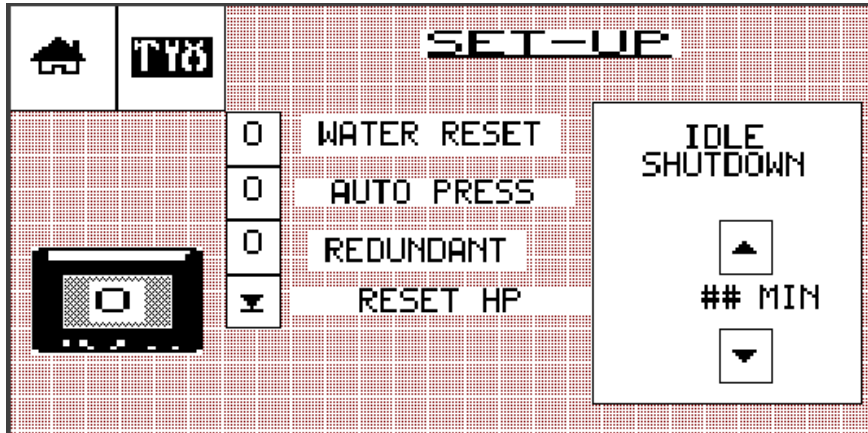

The Setup Screen for a standard machine displays the following functions:

- WATER RESET automatically shuts the inlet water solenoid valve five minutes after the machine shuts down; press the control to turn it ON or OFF
- AUTO PRESS momentarily opens the dump valve on each transition from high to low pressure for rapid pressure relief independent of the cutting orifice; press the control to turn it ON or OFF
- REDUNDANT specifies if the machine is a single or redundant model; press the control to turn it on for redundant or off for single
- RESET HP is only pressed when a new version of the display program is installed
- IDLE SHUTDOWN automatically stops the motor after a deadhead condition occurs; press the ▲ or ▼ arrow to select an idle time from 5-60 minutes

Figure 4-9: Setup Screen - Pressure Transducer and Proportional Pressure Control

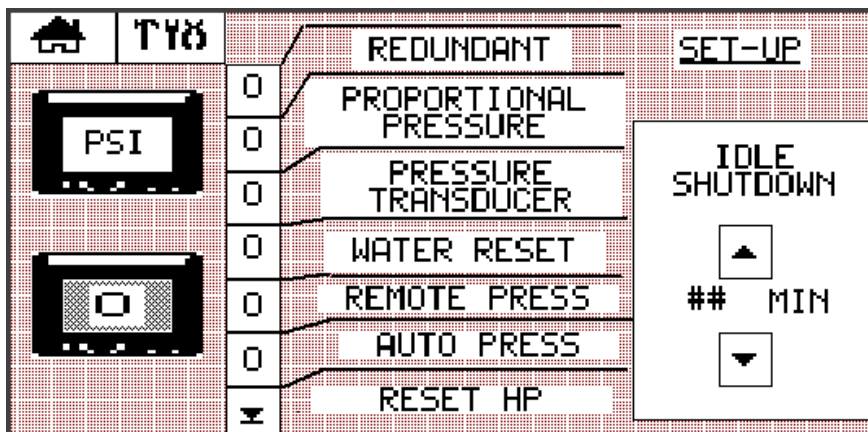

The Setup Screen in Figure 4-9 and the following functions will display if the machine is equipped with analog control modules:

- PSI/BAR selector changes the pressure display on the Run Screen and the Pressure Control Screen, if applicable; press the button to display output pressure as psi or bar. Recalibration of the transducer is automatic and does not require operator input.
- REDUNDANT specifies if the machine is a single or redundant model; press the control to turn it ON for redundant or OFF for single
- PROPORTIONAL PRESSURE allows the output pressure to be set from the Pressure Control Screen; press the control to turn it ON or OFF
- PRESSURE TRANSDUCER displays the output pressure on the Run Screen and the Pressure Control Screen, if applicable; press the control to turn it ON or OFF
- WATER RESET automatically shuts the inlet water solenoid valve five minutes after the machine shuts down; press the control to turn it ON or OFF
- REMOTE PRESSURE allows the output pressure to be set from a remote 0-10V signal; press the control to turn it ON for remote pressure input or OFF to enable default local control features
- AUTO PRESS momentarily opens the dump valve on each transition from high to low pressure for rapid pressure relief independent of the cutting orifice; press the control to turn it ON or OFF
- RESET HP is only pressed when a new version of the display program is installed
- IDLE SHUTDOWN automatically stops the motor after a deadhead condition occurs; press the ▲ or ▼ arrow to select an idle time from 5-60 minutes

4.8 Stroke Rate Screens

The graph on the right side of the Stroke Rate Screen monitors the real time strokes per minute. The Stroke Rate Screen in Figure 4-10 displays for a single intensifier. Figure 4-11 displays on redundant models. Both screens display the following functions:

Figure 4-10: Stroke Rate Screen - Single Intensifier

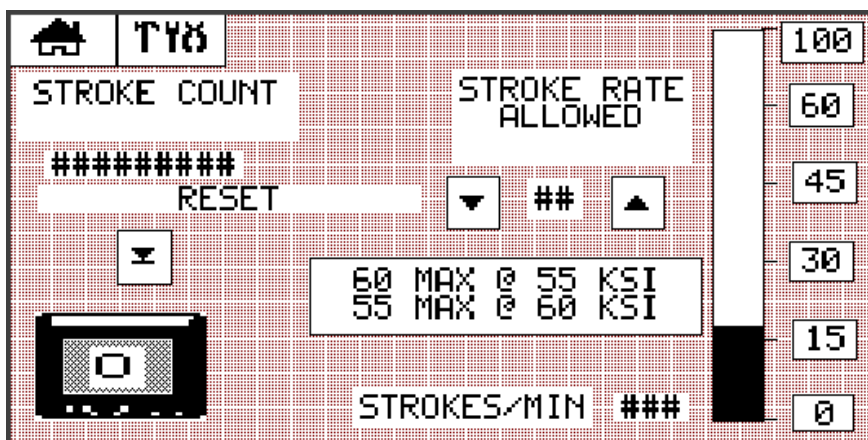

- STROKE COUNT displays the total number of strokes since the count was reset
- RESET the stroke count by pressing the ▼ arrow button
- STROKES/MIN displays the actual strokes per minute

- STROKE RATE ALLOWED increases or decreases the allowed stroke rate; press the ▲ or ▼ arrow to select the rate. Stroke rate should be set slightly higher than the desired operating rate to shutdown the machine quickly in the event of an overstroke condition.

Figure 4-11: Stroke Rate Screen - Redundant

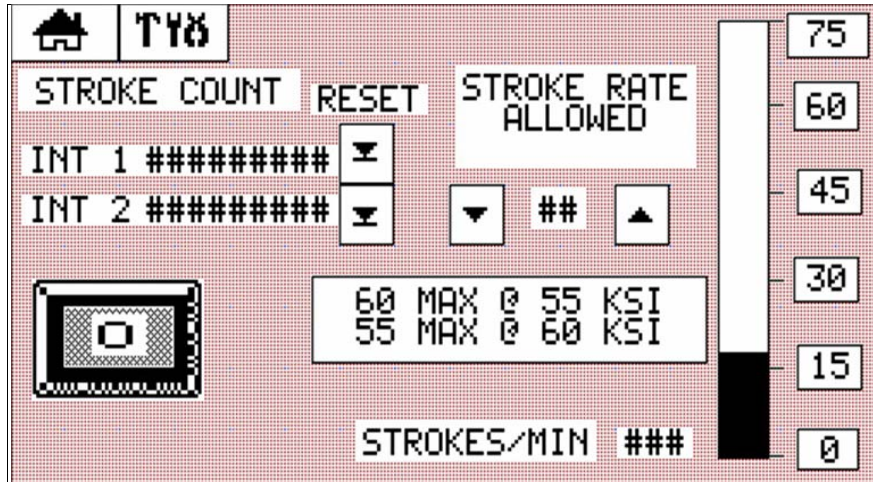

The upper limit points displayed on the Stroke Rate Screen are preset according to the horsepower rating of the machine. Table 4-2, Overstroke Set Points, illustrates the upper limits for the complete SL-V series. It also shows the number of strokes per minute above the setting that will result in a warning or shutdown condition.

Before setting the stroke rate you can monitor the graph to assess the actual stroke rate during normal operation. The stroke rate allowed should then be set 20% above that rate.

Table 4-2
Overstroke Set Points

Horsepower	Maximum Limit		Strokes Per Minute Added to Stroke Rate Allowed	
	55,000 psi	60,000 psi	Warning	Shutdown
30	37	34	2	4
50	60	55	2	4
60	75	71	3	6
75	57	53	2	4
100	79	75	3	6

Example

You are operating a 75 horsepower machine and the allowable stroke rate is set at 40 strokes per minute. If the stroke rate reaches 42, an overstroke warning will be issued after 15 seconds. The warning will continue until the rate returns to normal, or exceeds the overstroke shutdown point.

If the stroke rate reaches 44 an overstroke shutdown pending will be issued. If the condition exists for 30 seconds, an automatic shutdown will occur.

4.9 Hours Screens

The Hours Screen displays total machine operating hours and maintenance hours. Operating hours cannot be reset. Maintenance hours can be reset by pressing the reset maint hours button. The Hours Screen in Figure 4-12 displays when the machine has a single intensifier. The Hours Screen in Figure 4-13 displays when the machine is a redundant model.

Figure 4-12: Hours Screen - Single Intensifier

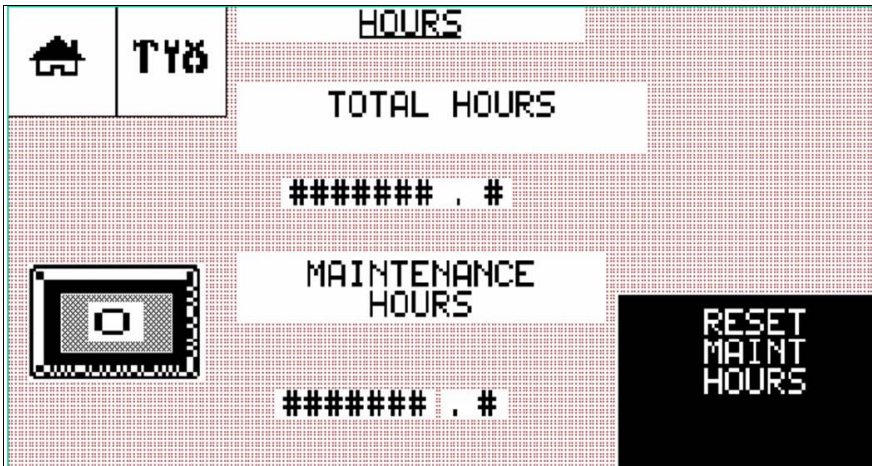
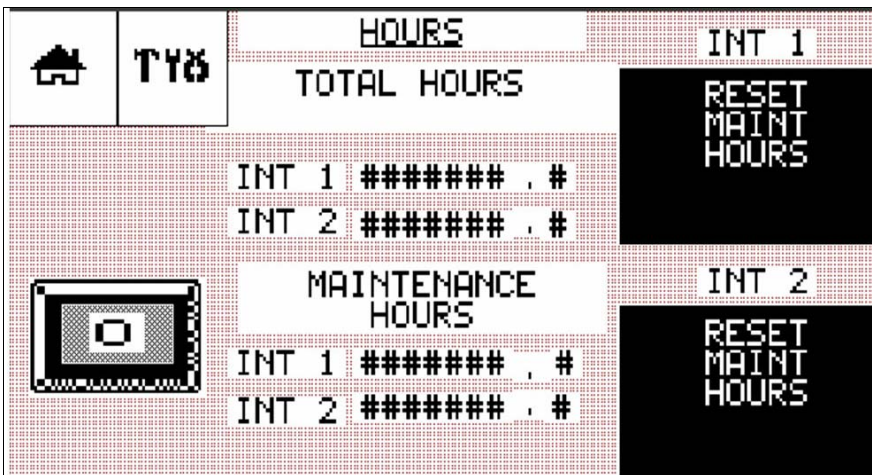

Figure 4-13: Hours Screen - Redundant



4.10 Run Screen Alarms

In an alarm state, the *last* alarm sensed by the machine will be displayed on the Run Screen. If multiple alarm conditions have occurred they can be viewed on the Alarms Screen. Run Screen alarms are listed in Table 4-3.

Figure 4-14: Run Screen Alarm

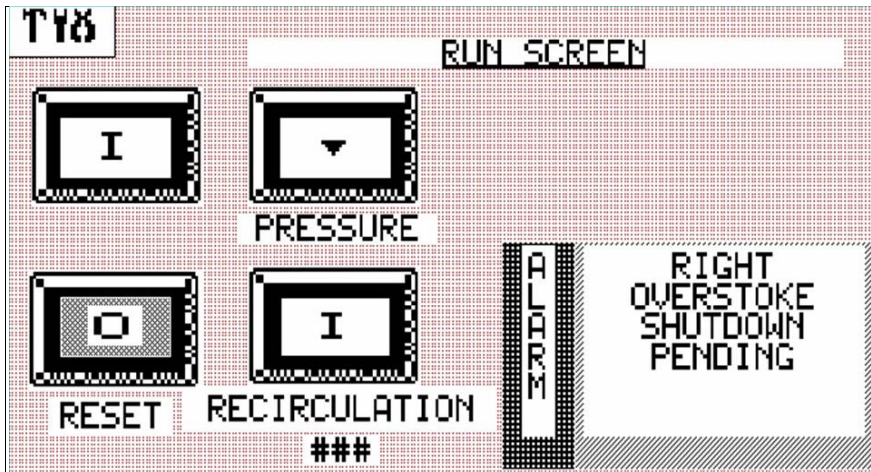

Table 4-3
Run Screen Alarms

Alarm	Indication	Comments
Bleed High Pressure Lines	Intensifier is shut down, high pressure is present in the discharge plumbing and should be bled off to avoid possible injury	Applies only when equipped with optional pressure transducer
Booster Temperature High	Booster pump water temperature is high, in excess of 128° F (53° C).	Shutdown will occur if condition persists.
High Oil Temperature	High hydraulic oil temperature, in excess of 144° F (62° C)	Shutdown will occur if condition persists.
High Pressure Warning	Output pressure is above 64,000 psi (4,413 bar)	Applies only when equipped with optional pressure transducer

Table 4-3
Run Screen Alarms

Alarm	Indication	Comments
Left/Right/Intensifier Overstroke	Abnormally high stroke rate caused by an external or internal leak. Shutdown will occur if condition persists.	Overstroke warnings, pending shutdowns and shutdowns are issued as left, right or intensifier. An intensifier warning or shutdown indicates the intensifier is shifting too fast in both directions. If the machine is running near full capacity it is possible an intensifier shutdown is actually caused by a left or right fault. This can be diagnosed further by reducing the operating pressure and monitoring all alarm occurrences on the Alarms Screen. If the machine is equipped with a pressure transducer, another level of overstroke protection is obtained by shutting down at the warning level if the pressure is less than 3,000 psi (207 bar).
Low Battery	Battery is low. After the alarm occurs, the battery will last for approximately seven days.	Replace with backup/replacement battery.
Low Booster Pressure	Booster pump output pressure is inadequate for proper machine operation, less than 60 psi (4 bar). Shutdown is pending.	Seven seconds after the machine is started, the booster pump output pressure switch is monitored. If the switch opens, a warning is issued. If the condition persists, shutdown will occur after 30 seconds.
Low Inlet Water Pressure	Cutting supply water pressure is inadequate to permit proper machine operation, less than 30 psi (2 bar).	If the inlet cutting watering pressure switch is not closed the machine will not start and a warning is issued. If the switch opens after the machine is started a warning is issued. If the condition persists shutdown occurs after five consecutive seconds.
Reset Inlet Water	Inlet water solenoid valve must be reset. RESET will flash and can be reset by pressing the STOP button	

4.11 Alarm Banners

When a shutdown condition occurs an Alarm Banner will appear over the current screen. The banner displays the type of shutdown and lists possible remedies. Potential remedies are listed in order of most to least probable.

Figure 4-15: Alarm Banner

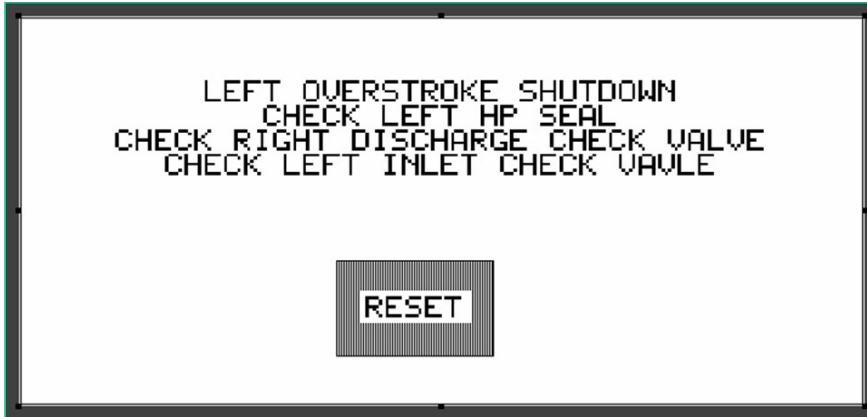

Pressing the RESET button will clear the alarm banner, but it will not clear the fault. The banner will continue to display until the fault is corrected. Shutdowns will appear on the Alarm History Screen. Alarm banner shutdowns are listed in Table 4-4.

Table 4-4
Alarm Banner Shutdowns

Alarm	Indication	Possible Remedies
Booster Temp High	High booster water temperature	Check bleed orifice in low pressure water manifold
		Check for long idle times
		Check the inlet water switch
Left Overstroke Shutdown	A left overstroke condition has occurred	Check left HP seal
		Check right discharge
		Check left inlet check valve
Long Idle Time Shutdown	Intensifier has run in a deadhead condition for the operator adjusted time limit (5 to 60 minutes)	

Table 4-4
Alarm Banner Shutdowns

Alarm	Indication	Possible Remedies
Low Booster Pressure	Low water pressure from booster pump	Check booster adjustment
		Check booster condition
Low Inlet Water Pressure	Low inlet water pressure	Check water supply
		Check water filter
Motor Feedback Failure	Start relay did not close at start-up or opened due to a fault	Check the motor starter relay
Motor Overload	PLC monitors the motor overload relay and displays a message when the overloads trip. Overloads are set on automatic reset.	Check incoming voltage
		Check overload setting
		Check the motor amperage
Oil Level Low	Low oil level	Check level gauge
		Check for hydraulic leaks
		Check the oil level switch
Right Overstroke Shutdown	A right overstroke condition has occurred	Check right high pressure seal
		Check left discharge
		Check right inlet check valve
T/W Overstroke Shutdown	An intensifier overstroke condition has occurred	Check plumbing for leaks
		Check high pressure orifice
		Check incoming water pressure
		Check inlet and discharge check valves

4.12 Alarms Screen

Multiple alarms can be viewed on the Alarms Screen. During normal operation, warning and pending alerts are not visible. If an alarm condition occurs the appropriate warning or pending message will display and flash. Table 4-5 describes these alarm conditions.

Figure 4-16: Alarms Screen

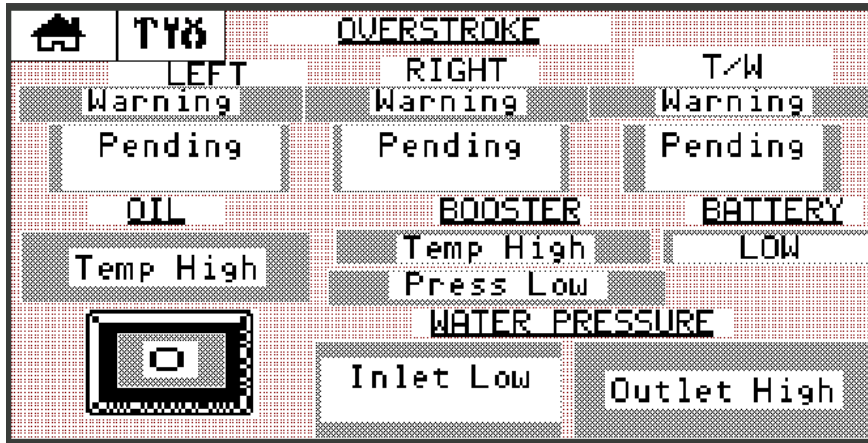

Table 4-5
Alarms Screen

Alarm		Indication	Result
Overstroke		High stroke rate caused by external or internal leak	First a warning, and then a pending shutdown alarm will occur. If the condition persists a shutdown will occur.
Oil		High oil temperature, in excess of 150° F (65° C)	Shutdown will occur 60 seconds after detection.
Booster	Temp High	High booster water temperature, in excess of 128° F (53° C)	Shutdown will occur 30 seconds after detection.
	Press Low	Low water pressure from booster pump, less than 60 psi (4 bar)	Shutdown will occur 20 seconds after detection.
Battery Low		Battery is low and needs to be replaced	The battery will last approximately seven days after the alarm occurs.
Water Pressure	Inlet Low	Low inlet water pressure, less than 30 psi (2 bar)	Shutdown will occur if condition persists for 5 continuous seconds.
	Outlet High	Excessively high outlet water pressure, in excess of 64,000 psi (4,413 bar)	Alarm available only if pressure transducer is installed. Does not result in a shutdown.

Installing a New Battery

The following procedure is used to change the replacement battery.



Do not attempt to remove the permanent battery.

1. Insert the new battery into the replacement battery pocket with the wires facing up.
2. Insert the wire connector for the replacement battery into the connector port.
3. Secure the battery wires under the wire latch as shown in Figure 4-17, Replace Battery.

Figure 4-17: Replacement Battery

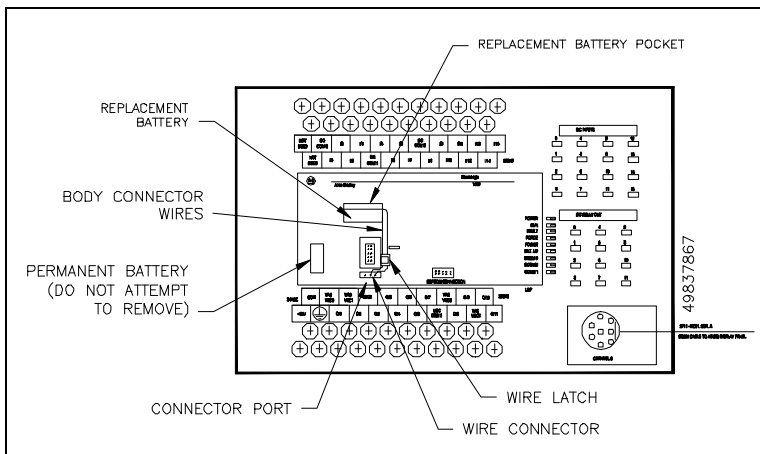

4.13 Alarm History

The Alarm History Screen displays the last 100 shutdown alarms indicating date, time and type of alarm. Use the ▲ or ▼ arrow to view past alarms.

Figure 4-18: Alarm History Screen

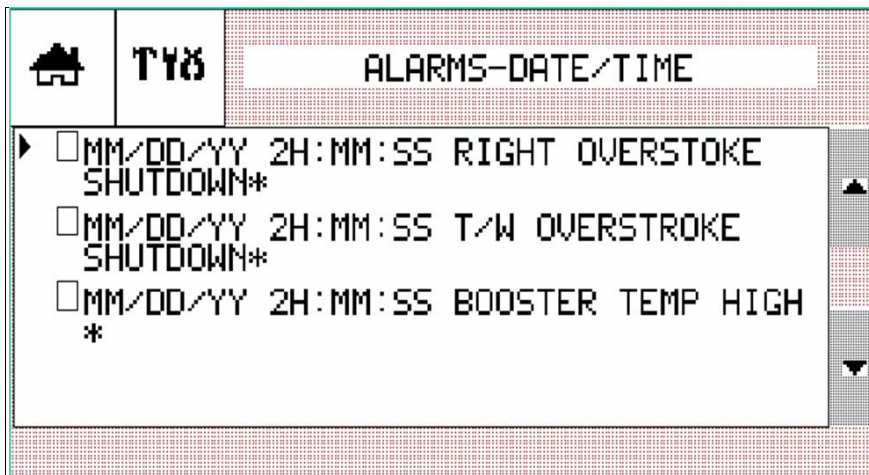

Changing the Date and Time

The following procedure is used to change the date and time.

1. Remove power from the display by pressing the e-stop button.
2. Pull the e-stop button out and press the RESET button to energize the display panel.
3. Shortly, the number 24 will display. Ten seconds later, the number 32 will replace the number 24 and a small blinking square will display on the bottom, right of the screen.
4. Press the blinking square to initialize the Configuration Screen used to set the parameters for the panel display.
5. Select Date/Time and press ENTER. Set the year, month, day, hour, minutes and seconds. Press EXIT to return to the previous screen.
6. Select Run Mode and press ENTER to return to the display panel.

4.14 Configuration Screen

The Configuration Screen is a password protected screen, used only at initial start up to set the horsepower. If a new version of the display program is installed you must press the reset hp button on the Setup Screen to update the displays.

4.15 Maintenance Screen

The Maintenance Screen is used to facilitate maintenance procedures and provides the PLC and display logic part number and revision number. When started from the Maintenance Screen, the machine starts in recirculation mode.



In recirculation mode the 4-way valve will shift to one side or the other, improving cooling efficiency. When the valve shifts it is possible for a small amount of high pressure water, 20,000 psi (1,379 bar), to be created. For this reason, it is suggested that the cutting orifice remain open during recirculation mode.

Figure 4-19: Maintenance Screen

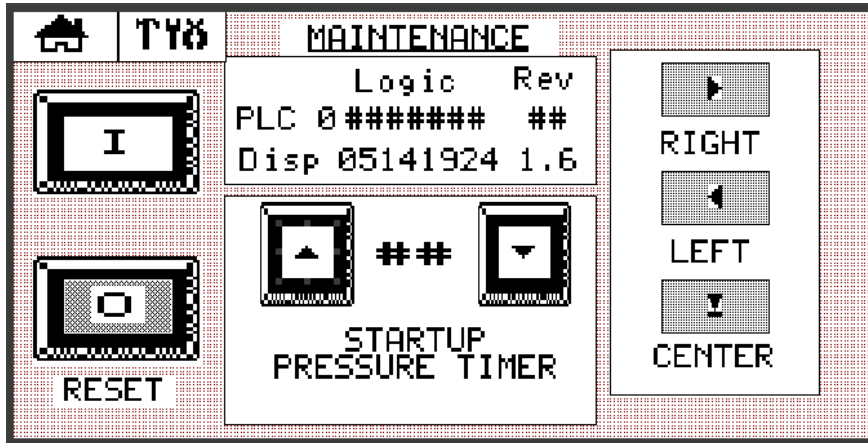

The machine must be started from the Maintenance Screen to access the following functions:

- START button will start the machine in recirculation mode and open the dump valve
- STOP button will stop the machine
- RESET is the inlet water solenoid indicator. The inlet water solenoid valve is automatically closed five minutes after the machine shuts down. When it flashes, press the stop button to reset and open the valve.
- STARTUP PRESSURE TIMER; press the ▲ or ▼ arrow to select a startup time from 5-60 seconds. This will determine the startup time between low and high pressure operation.
- RIGHT arrow will open the dump valve and extend the piston to the right, allowing full exposure to the right plunger when the unit is disassembled. ***The unit must be completely assembled to use this jog function.***
- LEFT arrow will open the dump valve and extend the piston to the left, allowing full exposure to the left plunger when the unit is disassembled. ***The unit must be completely assembled to use this jog function.***
- CENTER symbol will open the dump valve and position the piston in the center of the hydraulic cylinder. To center the piston, first press the right arrow to extend the plunger to the right, and then press the center symbol to center the piston. ***The unit must be completely assembled to use this jog function.***

4.16 Language Screen

The Language Screen lists the available display languages. Press the ▲ or ▼ arrow to highlight the desired language. Press enter (↵) to select.

Figure 4-20: Language Screen

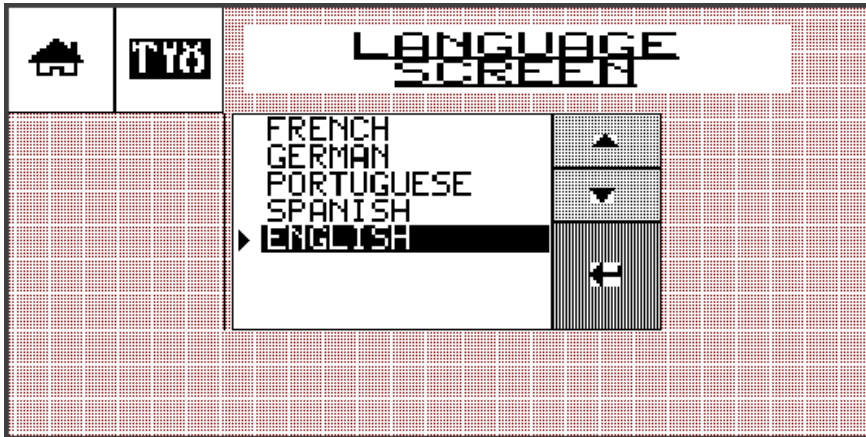



SECTION 5

LOW PRESSURE WATER SYSTEM

5.1 Overview

The SL-V series utilizes two low pressure circuits: cutting water supply and cooling water supply. This section will discuss the cutting water supply circuit. See Section 6, Recirculation System, for a detailed explanation of the cooling water supply circuit.

The cutting water supply circuit supplies the intensifier with the required cutting water flow and pressure. System components include the inlet water solenoid valve, strainer, booster pump, and the low pressure filter assembly. Pressure and temperature switches, connected to the PLC, monitor out of tolerance conditions in the cutting water circuit and provide automatic shutdown protection.

Figure 5-1: Cutting Water Supply Circuit

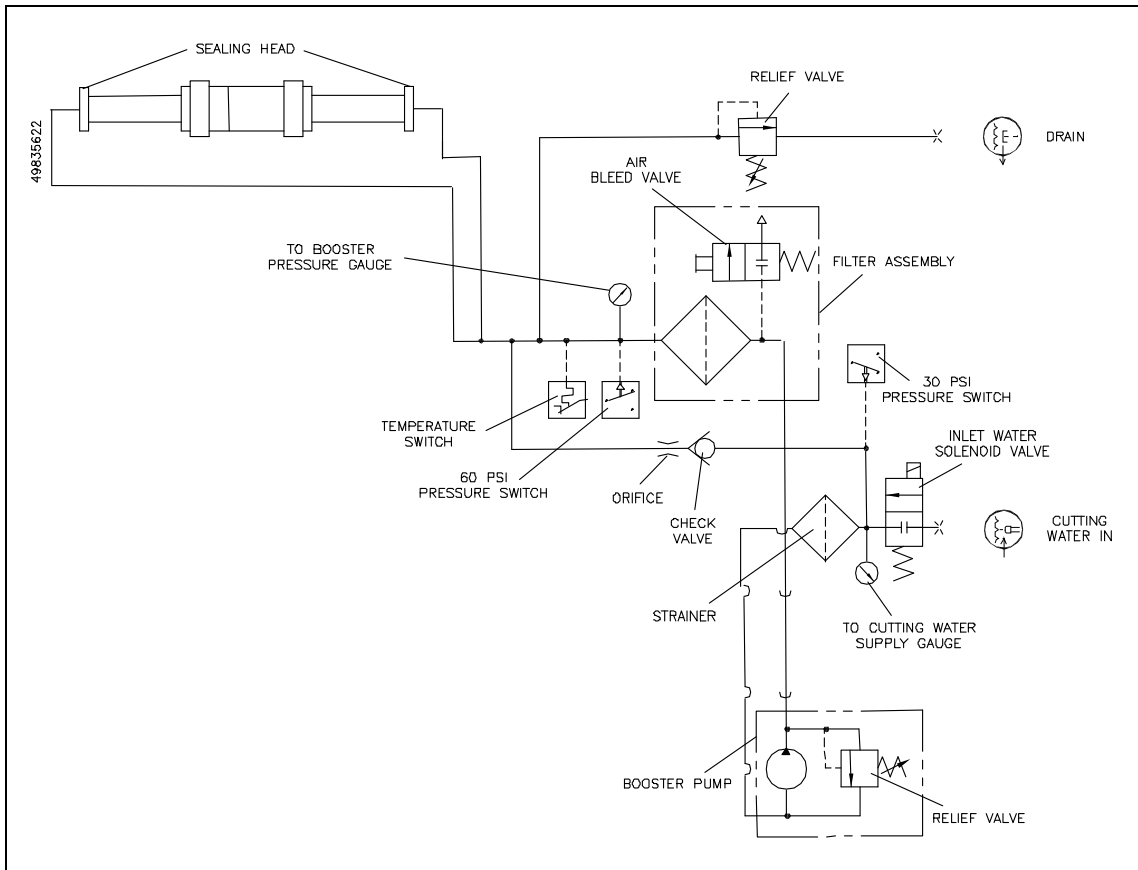

5.2 Cutting Water Supply

The quality of the inlet cutting water supply is one of the most important factors affecting component life and performance. Impurities in the water create grinding and corrosive effects on all components. See Section 11, Specifications, for details regarding water quality standards.

5.3 Operation

Cutting water is introduced through the 1/2-inch NPT connection on the rear bulkhead of the machine. Inlet cutting water pressure should be a minimum of 35 psi (2.4 bar) flowing, and can be monitored from the Cutting Water Supply Gauge on the front of the machine.

Figure 5-2: Low Pressure Water System

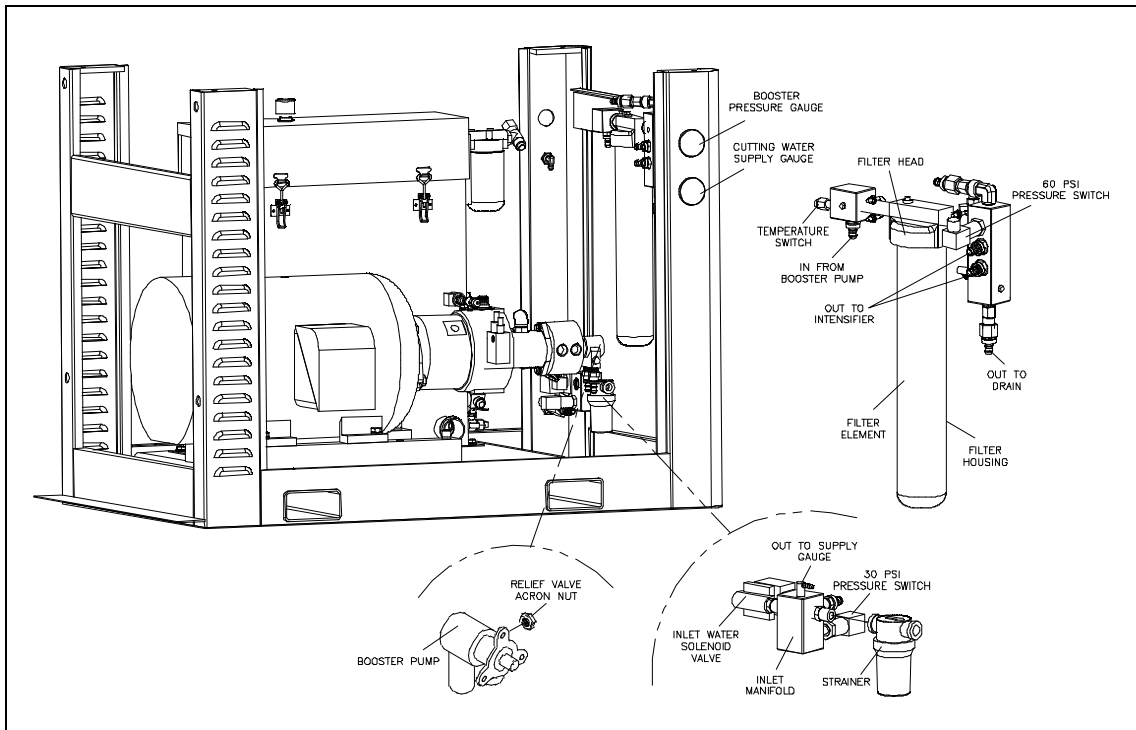

Cutting water enters through the normally closed, inlet water solenoid valve. When the control power is turned on, the solenoid valve opens and allows water to flow through the valve. The inlet water is monitored by a 30 psi pressure switch mounted on the inlet manifold. If the pressure drops below 30 psi (2 bar) the switch activates an automatic shutdown circuit in the PLC and the machine will not start.

NOTE

The machine will not start if inlet cutting water pressure is below 30 psi (2 bar).

If a shutdown occurs due to an overstroke condition, the inlet solenoid valve automatically closes to prevent water waste due to an external leak. Additionally, the valve automatically closes at the idle shutdown interval selected by the operator.

Cutting water then passes through a strainer to remove debris before the water enters the booster pump. The booster pump increases the pressure to the relief valve setting, up to a maximum of 120 psi (8 bar) to ensure proper supply to the intensifier assembly.

Pressurized water passes through the filter assembly where debris is removed to prevent contaminants from damaging the check valves and seals in the intensifier. The filter assembly consists of a filter head, housing and a 10 micron absolute filter. A bleed valve on the top of the filter head is used to release pressure or air inside the housing.

As the water enters the outlet manifold, the discharge pressure is monitored by a 60 psi pressure switch. An automatic shutdown will occur if the pressure is below 60 psi (4 bar).

If the booster pump pressure exceeds 125 psi (8.6 bar) a relief valve opens allowing water to exit through the 1/2-inch drain connection on the rear bulkhead. It is still possible to operate the machine; however, excess water will continue to be released through the drain.

Discharge pressure is displayed on the Booster Pressure Gauge on the front of the machine. The gauge should read approximately 120 psi (8 bar) while the machine is idling. When it strokes, the pressure drop should be no greater than 30 psi (2 bar). The water pressure range should remain between 90-120 psi (6-8 bar) during operation.

NOTE

While the intensifier assembly reverses direction, the boosted pressure will fluctuate slightly above and below the normal setting.

A relief valve built into the filter assembly prevents excessive discharge pressure and typically operates when the machine is in a deadhead condition. The booster pump is factory set to deliver 120 psi (8 bar) with an inlet pressure of 58 psi (4 bar). The pump may require adjustment to satisfy system requirements.

A temperature switch, mounted on the inlet manifold, monitors the discharge temperature. If the temperature exceeds 128° F (53° C), the switch activates an automatic shutdown circuit in the PLC that stops the main motor. The temperature switch prevents booster pump overheating due to lack of water or long deadhead conditions. To reduce overheating during a deadhead condition, water is re-circulated through the orifice and check valve, and routed back through the strainer to the booster pump inlet.

From the outlet manifold, cutting water is routed to the inlet check valves in the sealing heads on each end of the intensifier. If the machine is equipped with redundant intensifiers, the cutting water supply lines are manually connected to the active intensifier and manual hydraulic valves are opened or closed to direct the hydraulic flow to the active intensifier. Control is switched from one intensifier to the other from the control panel.

If the machine is equipped with dual intensifiers, cutting water and hydraulic fluid are routed to both intensifiers.

5.4 Service and Maintenance Procedures

To ensure water quality and supply to the high pressure system, the filter element, strainer and booster pump will require routine servicing and maintenance. The procedures for servicing these components are detailed below.

NOTE

Refer to Section 12, Parts List for a complete listing of replacement parts and part numbers.

Filter Assembly and Strainer Maintenance

The life of the filter element is directly related to the quality of the inlet water. The condition of the filter element can be monitored by observing the Booster Pressure Gauge on the front of the machine. Document the pressure reading when the filter element is new. The element should be replaced when the pressure drops to 15 psi (1 bar) below the original value. When the filter element is replaced, the strainer should also be cleaned.

The following procedure is used to replace the filter element and clean the strainer.

Figure 5-3: Filter Element

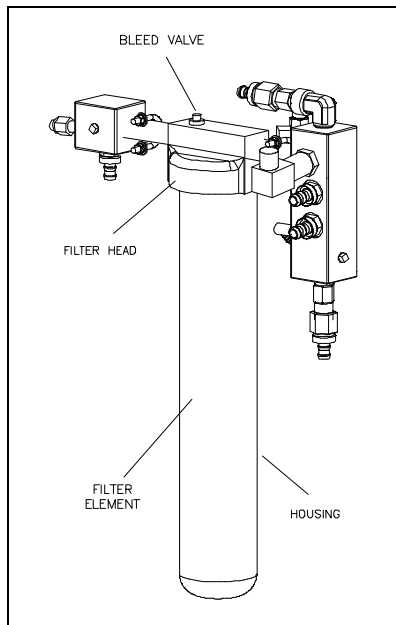

1. Turn the cutting water supply off.
2. Press the red bleed valve on the filter head to release any pressure trapped inside the housing.
3. Use a filter wrench to unscrew the housing and remove the old element.
4. Install the new element. Apply FML-2 grease to the o-ring in the filter housing and use the filter wrench to replace the housing.

NOTE

To ensure proper alignment of the element, fill the filter housing approximately 1/4 to 1/3 full of water. When the element is installed it will float, allowing it to be centered while the housing is installed on the filter head.

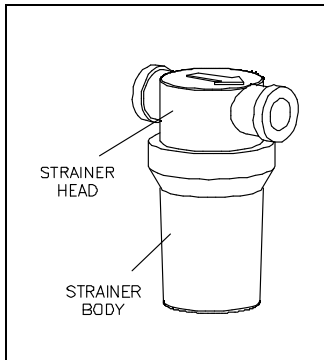
Figure 5-4: Strainer

5. Unscrew and remove the strainer body. Remove and clean the mesh liner.
6. Ensure the gasket is properly positioned in the body, install the liner and screw the strainer body into the strainer head, hand tighten.
7. Turn the cutting water supply on.
8. Press the red bleed valve to remove any air inside the housing.
9. Start the machine and verify satisfactory pressure readings.

Booster Pump Adjustment

If the discharge pressure from the booster pump stays below 90 psi (6 bar) while the intensifier is shifting, the relief valve on the booster pump should be adjusted.

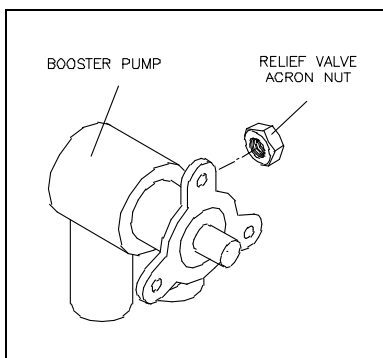
Figure 5-5: Booster Pump

1. Turn the cutting water supply on.
2. Start the machine and initiate normal, shifting operation.

3. Observe the discharge pressure from the booster pump. If the pressure stays below 90 psi (6 bar), continue with Step 4.
4. Stop the intensifier and remove the acorn nut on the side of the pump to access the adjustment screw. It is normal for water to leak out when the acorn nut is removed.
5. Use a flat screwdriver and turn the adjustment screw clockwise to increase the discharge pressure or counter-clockwise to decrease the pressure. Adjust the pressure to the highest desired pressure, within normal booster pump range.



If the adjustment screw is turned too far out (counter-clockwise) an internal spring and relief will fall down inside the pump. If this occurs, the pump must be removed and the parts must be reinstalled to avoid component damage.

6. Replace the acorn nut, resume normal operation and observe the booster discharge pressure. Peak pressure should be in the range of 90 to 120 psi (6 to 8 bar). If it is not, repeat the adjustment procedure.



SECTION 6

RECIRCULATION SYSTEM

6.1 Overview

The oil recirculation circuit is a cooling and filtration system that provides properly conditioned oil to the main hydraulic system. Hydraulic oil is maintained at the proper operating temperature and condition by continuous recirculation.

System components include the water modulating valve (oil-to-water models), recirculation pump, heat exchanger, oil filter assembly and the hydraulic oil reservoir. A temperature/low level switch, connected to the PLC, monitors temperature and oil level conditions in the hydraulic oil reservoir and provides automatic shutdown protection.

Figure 6-1: Oil Recirculation Circuit

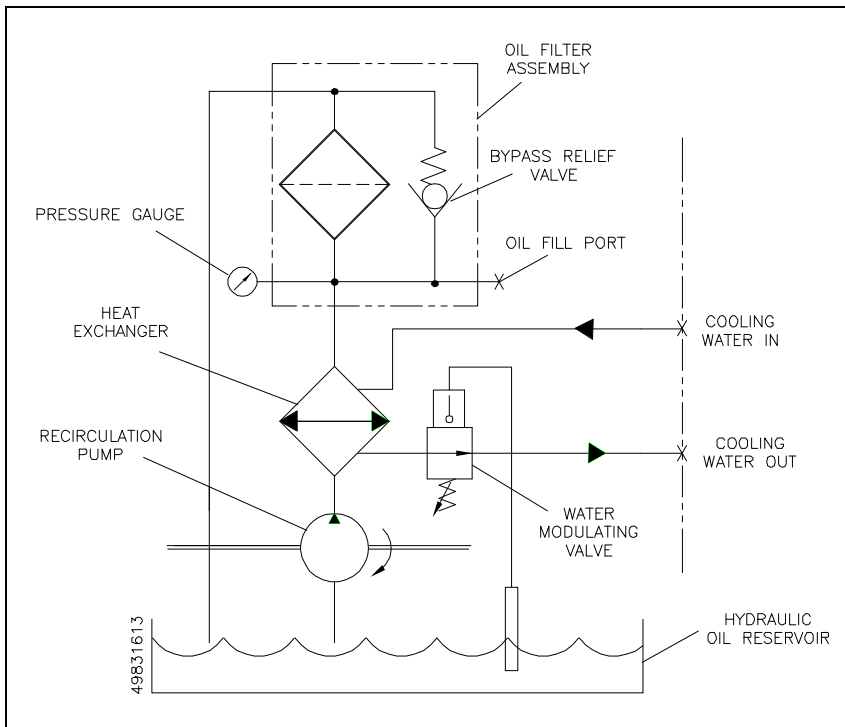

6.2 Operation (Oil-to-Water Models)

Cooling water is introduced through the 1/2-inch NPT connection on the rear bulkhead of the machine. A water modulating valve in the outlet line regulates the cooling flow through the heat exchanger. The valve is factory set, but may require adjustment to maintain the operating oil temperature at 115° F (46° C). Oil temperature can be visually monitored from a dual scale level/temperature sight gauge on the side of the hydraulic oil reservoir.

Figure 6-2: Recirculation System Components (Oil-to-Water)

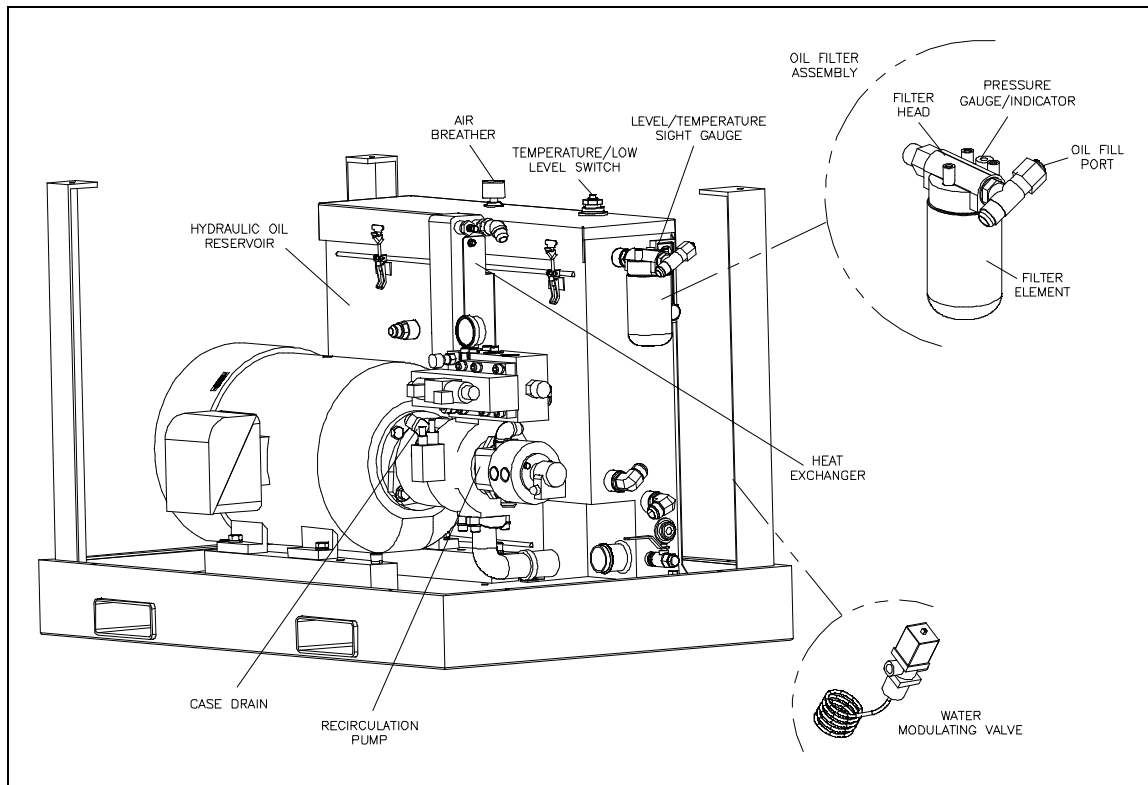

The recirculation pump pulls oil from the reservoir and sends it to the heat exchanger. The oil-to-water heat exchanger controls heat build-up in the hydraulic oil. The plate style design allows cooling water and oil to flow side by side through alternating plates.

The cooled oil then passes through the filter element and returns to the reservoir. The cooling water either is discharged to the 1/2-inch NPT drain on the rear bulkhead or is routed to a customer supplied water chiller.

The hydraulic oil filter assembly consists of the filter head, a filter element, pressure gauge or indicator, bypass relief valve and the oil fill port. All 30, 50 and 60 horsepower machines are equipped with a numeric pressure gauge that indicates inlet pressure. The filter element should be changed when the gauge reads 40 psi (2.8 bar) at normal operating temperature. The 75 and 100 horsepower machines utilize a differential pressure indicator. The filter element on these machines should be changed when the indicator enters the red zone at normal operating temperature.

If the element is not replaced, and fills with debris, the bypass relief in the filter head will open to prevent over pressurization. The relief valve opens at 50 psi (3.4 bar) on 30, 50 and 60 horsepower models, 25 psi (1.7 bar) on 75 and 100 horsepower models. When the valve opens, the oil bypasses the filter and unfiltered oil is allowed to return to the reservoir.

The temperature/low level switch monitors the oil temperature and level in the reservoir. An automatic shutdown will occur if the operating oil temperature exceeds 144° F (62° C). An automatic shutdown will also occur if the oil level on a 30, 50 or 60 horsepower machine falls below 28 gal (106 L). Low oil level shutdown occurs at 37 gal (140 L) on a 75 or 100 horsepower machine.

NOTE

To conserve water usage it is recommended that the cooling water be shut off at the end of the day. A sensor bulb from the modulating valve is submerged in the reservoir. Even when the control power is off, the valve will remain open, allowing water to flow until the oil is cooled.

6.3 Operation (Oil-to-Air Models)

The recirculation pump pulls oil from the hydraulic oil reservoir and sends it to the external heat exchanger. The oil-to-air heat exchanger controls heat build-up in the hydraulic oil. Oil temperature can be visually monitored from a dual scale level/temperature sight gauge on the side of the reservoir.

Figure 6-3: Recirculation System Components (Oil-to-Air)

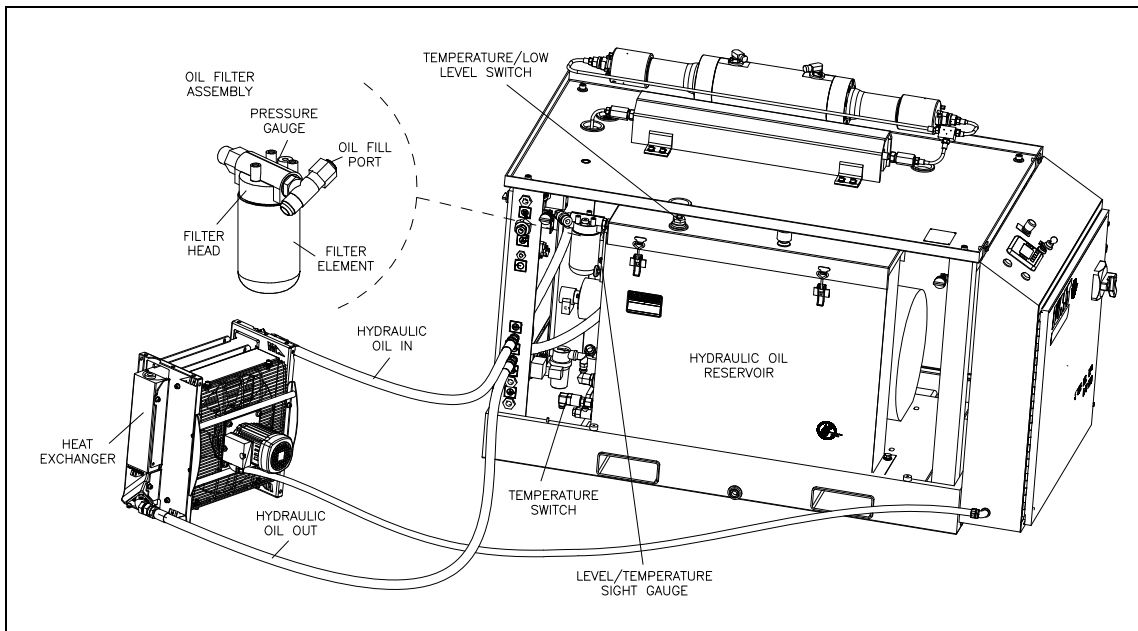

The temperature switch mounted on the reservoir monitors the oil temperature and regulates the air flow to the heat exchanger through a signal to the control panel to initiate power to the fan.

The cooled oil returns through the bulkhead, passes through the filter element and returns to the reservoir.

The hydraulic oil filter assembly consists of the filter head, a filter element, pressure gauge or indicator, bypass relief valve and the oil fill port. All 30, 50 and 60 horsepower machines are equipped with a numeric pressure gauge that indicates inlet pressure. The filter element should be changed when the gauge reads 40 psi (2.8 bar) at normal operating temperature. The 75 and 100 horsepower machines utilize a differential pressure indicator. The filter element on these machines should be changed when the indicator enters the red zone at normal operating temperature.

If the element is not replaced, and fills with debris, the bypass relief in the filter head will open to prevent over pressurization. The relief valve opens at 50 psi (3.4 bar) on 30, 50 and 60 horsepower models, 25 psi (1.7 bar) on 75 and 100 horsepower models. When the valve opens, the oil bypasses the filter and unfiltered oil is allowed to return to the reservoir.

The temperature/low level switch monitors the oil temperature and level in the reservoir. An automatic shutdown will occur if the operating oil temperature exceeds 144° F (62° C). An automatic shutdown will also occur if the oil level on a 30, 50 or 60 horsepower machine falls below 28 gal (106 L). Low oil level shutdown occurs at 37 gal (140 L) on a 75 or 100 horsepower machine.

6.4 Service and Maintenance Procedures

To ensure the supply of properly conditioned oil to the main hydraulic system, the components will require routine servicing and maintenance. The procedures for servicing these components are detailed below.

NOTE

Refer to Section 12, Parts List for a complete listing of replacement parts and part numbers.

Hydraulic Oil Maintenance

The hydraulic oil should be replaced after 3,000 hours or one year of service, whichever comes first. The oil should be replaced sooner if a fluid sample indicates contamination that cannot be rectified by filtering.

An air breather and filter is located on the top of the reservoir. The air breather prevents dirt from being sucked into the reservoir when the oil level drops, and allows air to escape when the level rises. The air breather must not be used as a fill point. Oil **must only** be replaced at the fill port on the filter head.

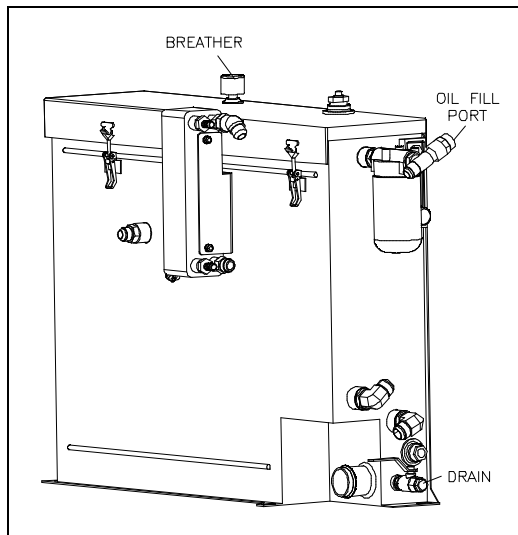

Do not attempt to fill the reservoir from the air breather. The oil will not be filtered and will not conform to the cleanliness requirements of the system.

Figure 6-4: Hydraulic Reservoir

Before proceeding, disconnect and lockout the main power supply and the electrical enclosure; and ensure that all high pressure water and hydraulic pressure has been bled from the system.



Severe injury can result if the machine is not properly locked out. Observe electrical Lockout/Tagout procedures before performing maintenance.

Ensure all pressure is relieved or blocked from the hydraulic and high pressure circuits before performing maintenance.

1. Drain the oil reservoir by connecting the inlet hose from an oil transfer pump to the drain valve on the reservoir.
2. Open the shut off valve on the drain and pump the used oil out to a container.
3. Close the shut off valve and remove the inlet hose from the drain valve.

NOTE

Oil from a new drum does not meet the cleanliness requirements of the hydraulic system. For this reason, it is important to use an oil transfer pump that will force oil through the return filter into the reservoir.

4. Remove the cap from the fill port on the oil filter.



To ensure cleanliness, the oil fill port **must** be used to pump oil into the reservoir. Filling at this point guarantees the hydraulic oil will pass through the oil filter before entering the reservoir.

5. Connect the discharge hose from the oil transfer pump to the fill port and pump the fresh oil into the reservoir.

NOTE

If 3/4-inch BSPP threads are required, install the adapter located on the inside of the frame. When filling is complete, remove the adapter and install the fill port cap.

6. Check the oil sight gauge on the reservoir to ensure proper fill level.
7. Remove the hose from the case drain on the main hydraulic pump to make sure the pump case fills with oil. With the hose removed, head pressure from the reservoir will force oil into the pump case.



Oil in the pump case provides internal lubrication for the main hydraulic pump. Failure to fill the pump case with oil will allow air to become trapped inside, damaging the pump.

8. Disconnect the discharge hose from the fill port and replace the fill port cap.
9. Follow the initial start up sequence in Section 4, Operation, to ensure the system is filled with oil.
10. Check the sight gauge again and follow the same procedure to add additional oil if necessary.

Electric Motor Bump

Bumping is defined as allowing the electric motor to start rotating, but stopping it before the motor gets up to full speed.

Whenever the hydraulic reservoir is emptied or the hydraulic pump has been changed, bumping the electric motor is suggested. This procedure will ensure the hydraulic pump is full of oil and deter cavitation which will cause the hydraulic pump to fail prematurely.

Do not perform this procedure until the correct motor rotation and the presence of hydraulic oil in the hydraulic pump case drain line has been confirmed.

1. Start the pump in recirculation mode, count two seconds and turn the pump off.
2. Repeat this process six times before allowing the hydraulic pump to create pressure.

Oil Filter Maintenance

If the filter element is not properly serviced and fills with debris, the oil will be forced through the relief valve, bypassing the filter. The bypass relief valve on 30, 50 and 60 horsepower models opens at 50 psi (3.4 bar), it opens at 25 psi (1.7 bar) on 75 and 100 horsepower models. The filter element must be replaced when the pressure gauge or indicator meets the criteria listed in Table 6-2.

Table 6-1
Hydraulic Oil Filter Change Criteria

Horsepower	Indicator	Criteria
30 50 60	Numeric pressure gauge	Replace filter element when the pressure reading is 40 psi (2.8 bar) or greater during normal operating conditions.
75 100	Differential pressure indicator	Replace filter element when the indicator is in the yellow zone or entering the red zone during normal operating conditions.

Note: Normal operating conditions indicate the machine is running and the oil temperature has reached 115° F (46° C).

Figure 6-5: Oil Filter Assembly

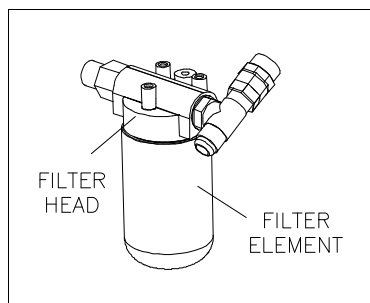

1. Use a filter wrench to unscrew the filter element from the filter head. Make sure the old gasket is removed with the element.
2. Lubricate the gasket on the new element with fresh oil.
3. Use the filter wrench to screw the new element onto the filter head and hand-tighten. Do not over tighten.
4. Start the machine and check for leaks.

NOTE

If the pressure gauge reads 40 psi (2.8 bar) or greater, or the indicator is in the red zone after the filter is changed, check the operating condition of the gauge or indicator. These components may require replacement.

Operating Temperature Adjustment (Oil-to-Water Models)

The cooling water flow through the heat exchanger is regulated by the water modulating valve, a manually adjusted, thermostatic control valve. The valve is factory set to maintain the operating oil temperature at 115° F (46° C). It is adjusted by increasing or decreasing the spring tension on the valve.

NOTE

In most cases, adjustment will be required during commissioning and with seasonal changes to the cooling water temperature.

Figure 6-6: Water Modulating Valve

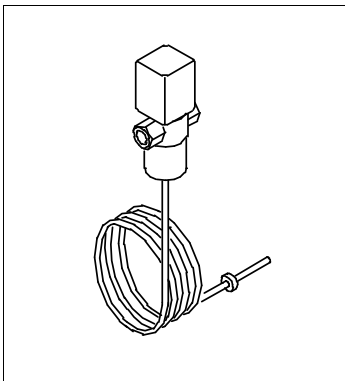

1. Locate the adjusting knob, a screwdriver slot on the top of the valve.
2. Use a flat screwdriver and turn counter-clockwise to compress the spring, slowing water flow and increasing temperature. Or; turn clockwise to reduce spring tension, increasing water flow and decreasing the temperature.
3. Monitor the sight gauge on the side of the reservoir until the adjusted temperature can be determined. It will take some time for the temperature in the oil reservoir to change.
4. Repeat steps 2 and 3 if necessary.



SECTION 7

HYDRAULIC SYSTEM

7.1 Overview

The main hydraulic power circuit supplies the intensifier assembly with the hydraulic oil required to produce high pressure water. High pressure cutting water is generated from the oil pressure in the hydraulic cylinder.

System components include the electric motor, hydraulic pump, 4-way directional control valve and the hydraulic manifold. The manifold houses the high and low pressure control valves, hydraulic gauge, two pressure solenoid valve and the main system relief valve. The system relief valve monitors hydraulic oil pressure and provides system protection by limiting excess pressure.

Figure 7-1: Main Hydraulic Power Circuit

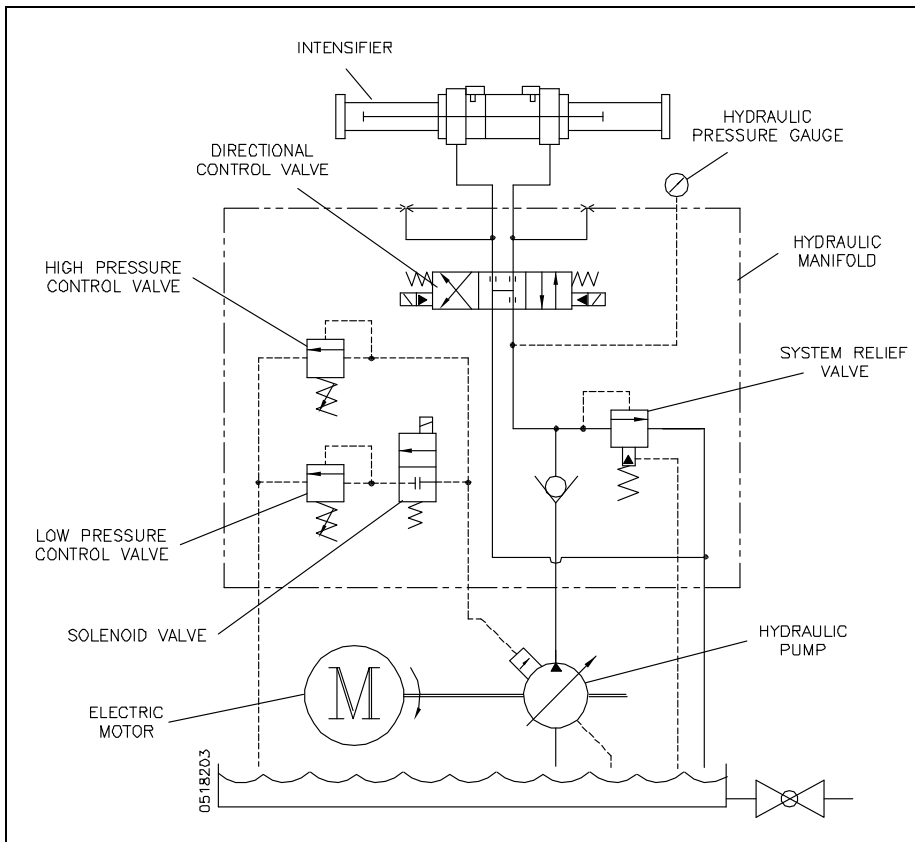

7.2 Optional System Components

Optional proportional pressure control enhances the standard high and low pressure selection by allowing the operator to select or vary the hydraulic operating pressure from the control panel or from a remote console. From the Pressure Control Screen the high pressure can be set as a percentage, from 0% to 100%. An electronically controlled hydraulic cartridge valve receives a signal from the PLC and automatically makes the operator selected adjustments.

As proportional pressure controls hydraulic oil pressure, it also determines cutting water pressure based on the intensification ratio.

7.3 Operation

The electric motor drives three pumps mounted in tandem; the main hydraulic pump, the recirculation pump and the booster pump. The motor drives the variable displacement, pressure compensated hydraulic pump by means of a flexible coupling.

Hydraulic fluid from the reservoir is drawn into the inlet, low pressure side of the hydraulic pump. Oil delivered to the pump should be maintained at 110-115° F (43-46° C). Hydraulic fluid then enters the bottom of the manifold through an internal anti-rotation check valve. After a shutdown, the anti-rotation check valve prevents the pump from running backwards.

Figure 7-2: Hydraulic System Components

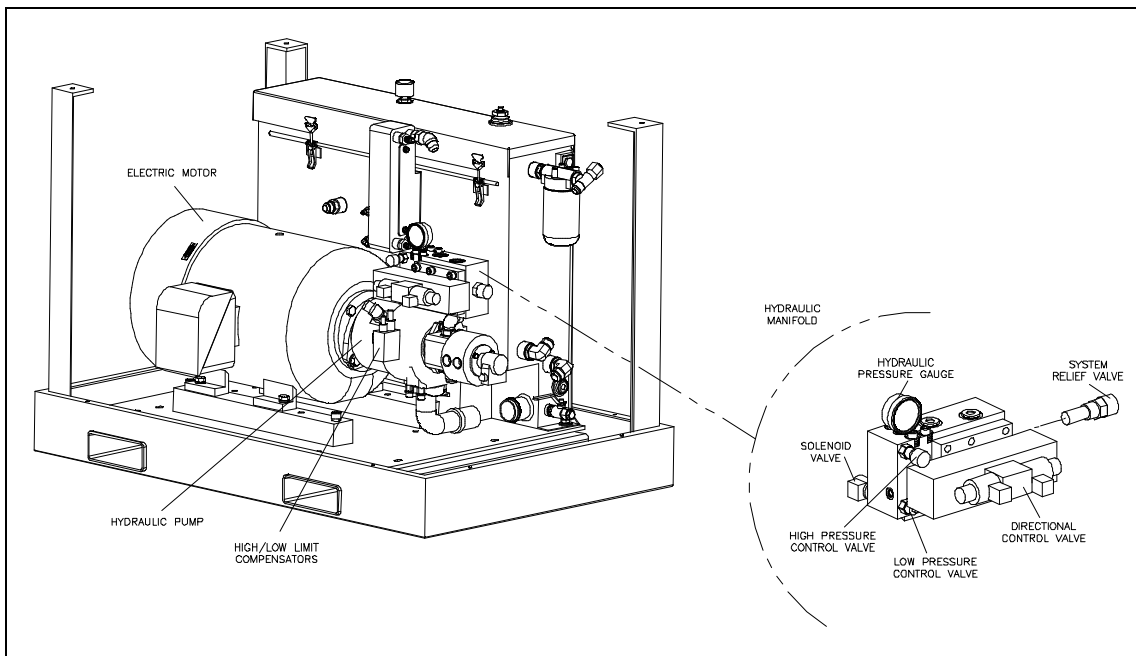

The main system relief valve provides system protection by monitoring the oil pressure entering the manifold. If the hydraulic pressure exceeds 3,400 psi (234 bar), the valve opens to limit the pressure. The valve is factory calibrated and is not serviceable. A drain line from the valve prevents oil from collecting behind the relief valve to ensure a constant pressure under all operating conditions.

The hydraulic system operates at high or low pressure settings up to the maximum flow capacity of the hydraulic pump. The high and low limit compensators mounted on the pump regulate the flow of hydraulic fluid to maintain constant operating pressures. Operating pressures are set and adjusted at the high and low pressure control valves on the manifold.

If the machine is equipped with proportional pressure control, low pressure is adjusted at the manifold, and the high pressure setting is made from the control panel or a remote console.



The high and low limit compensators regulate the flow of hydraulic fluid to the system by controlling the angle of the swashplate. If the oil is not properly maintained, the compensators can become blocked with debris. As a result, pump control will be lost and you will not be able to create hydraulic oil pressure.

The normally closed, two pressure solenoid valve is controlled by the operator's selection of high or low pressure. The valve is closed while operating in high pressure and is open during low pressure operation. A light on the solenoid connector indicates low pressure operation.

At startup, hydraulic pressure is automatically switched to low, limiting torque demand. After 5-60 seconds, depending on the interval selected by the operator, hydraulic pressure automatically returns to the previously selected pressure setting.

A reference gauge on the top of the manifold displays hydraulic pressure to the intensifiers. When the intensifier shifts, it is normal for the pressure to quickly fall and then rise again.

The 4-way directional control valve directs pressurized oil to one end the hydraulic cylinder and returns fluid to the reservoir from the opposite end, causing the intensifier to stroke. The movement is controlled hydraulically by a pilot valve that is electronically operated by two solenoids, energized by the PLC. Indicators light up as each solenoid is energized.

The directional control valve sends flow to the hydraulic cylinder in one direction until the hydraulic piston activates the proximity switch at the end of the stroke. The activated switch sends a signal to the PLC to reverse the direction of flow. The piston then moves in the opposite direction until it activates the proximity switch at the opposite end of the stroke.

If the machine is equipped with redundant intensifiers, manual hydraulic valves are opened or closed to direct the hydraulic flow to either intensifier. If the machine is equipped with dual intensifiers, the directional control valve supplies hydraulic pressure to both intensifiers.

7.4 Service and Maintenance Procedures

The extreme duty cycles demanded of the hydraulic system make routine inspection and maintenance acutely important. Leaks must be detected and remedied as soon as possible.

The operating pressure settings must be checked daily, and the electric motor must be inspected at regular intervals. It is also possible for the flexible coupling to fail and require replacement. The procedures for servicing these components are detailed below.

NOTE

Refer to Section 12, Parts List for a complete listing of replacement parts and part numbers.

Hydraulic Operating Pressure

Hydraulic operating pressure settings should be checked daily and adjusted as necessary. High and low operating pressure on standard machines is adjusted at the high and low pressure control valves per the specifications in Table 7-1.

For machines equipped with proportional pressure control, high pressure adjustments are made from the Pressure Control Screen on the control panel. The following specifications and the Low Pressure Adjustment procedure are used for low pressure adjustments.

NOTE

The pressure switch on the control panel must be set to high pressure to enable the proportional pressure control.

Table 7-1
Hydraulic Operating Pressure Limits

	Adjustment		Pressure Limits		
	Increase	Decrease	Minimum	Maximum	
				30/50/60HP/100D	75/100HP
High Pressure	Clockwise	Counter-clockwise	290 psi (20 bar)	3,000 psi (207 bar)	2,600 psi (179 bar)
Low Pressure	Clockwise	Counter-clockwise	290 psi (20 bar)	1,500 psi (103 bar)	

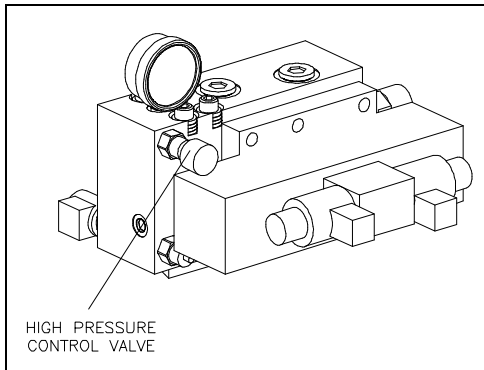
Figure 7-3: High Pressure Control Valve

1. Check the operating pressure to determine if adjustment is necessary.
2. If high pressure adjustment is required, loosen the locking nut on the high pressure control valve by turning counter-clockwise.
3. Turn the knob on the control valve clockwise to increase operating pressure. Turn the knob counter-clockwise to decrease pressure.
4. Tighten the locking nut and verify the high pressure setting.

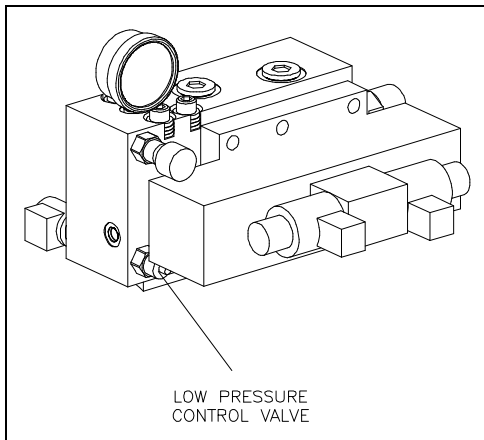
Figure 7-4: Low Pressure Control Valve

1. Check the operating pressure to determine if adjustment is necessary.
2. If low pressure adjustment is required, loosen the locking nut on the low pressure control valve by turning counter-clockwise.
3. Turn the hex clockwise to increase operating pressure. Turn the hex counter-clockwise to decrease pressure.
4. Tighten the locking nut and verify the low pressure setting.

Proportional Pressure Valve Maintenance

The screen in the optional proportional valve can become blocked with debris resulting in erratic pressure fluctuations or the inability to reach or maintain the operating pressure.

Figure 7-5: Proportional Valve

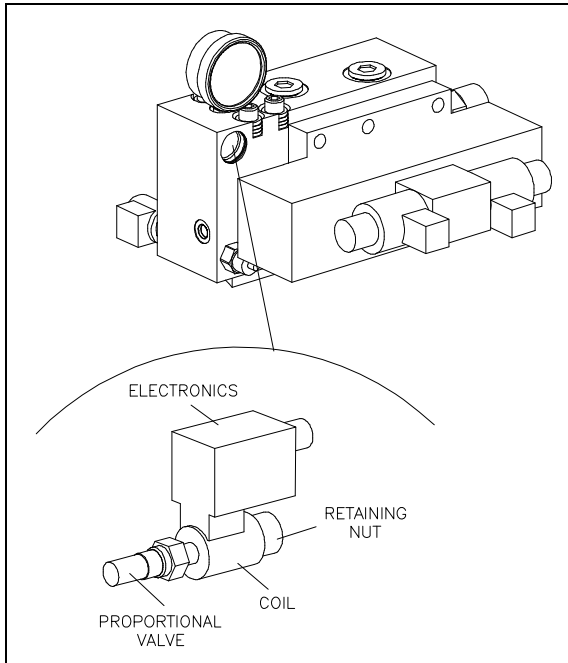

1. Unscrew and remove the retaining nut on the proportional pressure valve.
2. Remove the coil and electronics from the valve.
3. Unscrew and remove the valve from the hydraulic manifold.
4. Use air or alcohol to clean the screen inside the valve.

NOTE

A blocked screen will appear black. Clean the screen until it is clear.

5. Screw the cleaned valve into the hydraulic manifold.
6. Replace the coil and electronics.
7. Replace the retaining nut.

Motor Maintenance

The motor should be inspected at regular intervals, approximately every 500 hours of operation or every three months, whichever occurs first. Keep the motor clean and the ventilation openings clear.

Flexible Coupling Replacement

When the flexible coupling fails, the pump shaft will not turn and pressure will not be created. Typically, failure will be sudden, without any warning signs.

The electric motor and hydraulic pump are mounted in tandem on all SL-V models. Although the configuration is the same, the motor, pump, mountings, connections and components vary slightly according to horsepower. The procedure for replacing the flexible coupling is the same for all models.

Figure 7-6: Flexible Coupling Replacement

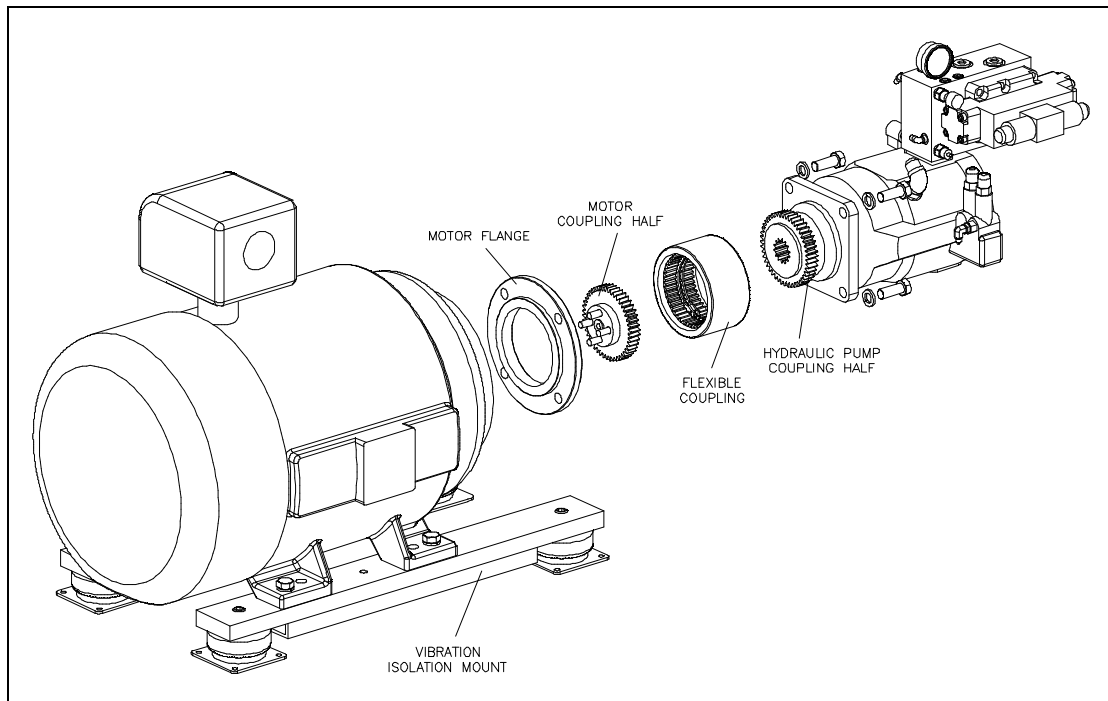

Severe injury can result if the machine is not properly locked out. Observe electrical Lockout/Tagout procedures before performing maintenance on the system components.

Ensure all pressure is relieved or blocked from the hydraulic and high pressure circuits before performing maintenance.

1. Remove the bolts attaching the motor vibration mounts to the frame base plate.
2. Use wooden blocks to support the hydraulic pump and manifold assembly. Leave all hose connections intact.

NOTE

A forklift can also be used by trained, experienced personnel to support the pump and manifold assembly.

3. Remove the bolts attaching the hydraulic pump to the electric motor.
4. Slide the motor away from the pump and manifold assembly to expose the flexible coupling.

NOTE

If additional clearance is required to separate the motor and pump, the electrical panel can be removed from the end of the frame. Remove the hex nuts from the studs holding the electrical panel. Move the panel 4-8 inches away from the frame.

It should not be necessary to disconnect the motor lead wires. However, the wire ties holding the electrical control harness to the top pan will need to be removed in order to move the electrical panel.

5. Remove the failed flexible coupling.
6. Wipe any residue, dirt or oil from the coupling halves on both the motor shaft, and the pump shaft. Avoid damaging the shaft seal on the pump.

NOTE

Additional clearance and access to the motor and pump coupling can be achieved by moving the pump and manifold assembly to the right. The pump suction hose will limit movement to approximately one inch. It should not be necessary to disconnect any hydraulic hoses.

7. Inspect the metal splines on the coupling halves for damage. If damage is detected, replace the coupling half.
8. Inspect the shaft cavity of the hydraulic pump for the presence of hydraulic oil or evidence of hydraulic leaks. If a hydraulic leak is detected, the shaft seal must be replaced.
9. Install the new flexible coupling over the coupling half on the motor shaft, aligning the splines, and push the flexible coupling on as far as it will go. The internal ring or snap ring keeps the coupling centered between the motor and pump shafts.
10. Move the motor and pump assembly together to re-engage the flexible coupling with the coupling half on the pump shaft. You may need to turn the motor shaft to align the splines with the pump shaft. When the motor and pump are rejoined, the coupling will have a small amount of end clearance to allow the coupling to float.
11. Attach the pump to the motor by reinstalling the bolts, and remove the wooden blocks.
12. Reinstall the vibration mounts to the frame base plate.

13. Reinstall the electrical panel to the end of the frame, if necessary.
14. Start the motor and apply full high pressure water pressure. Note any unusual sounds from the motor or pump assembly.

Hydraulic Compensator Maintenance

The high and low limit compensators regulate the flow of hydraulic fluid to the system. The compensators can become blocked with debris resulting in loss of pump control.

Figure 7-7: Hydraulic Compensator Components

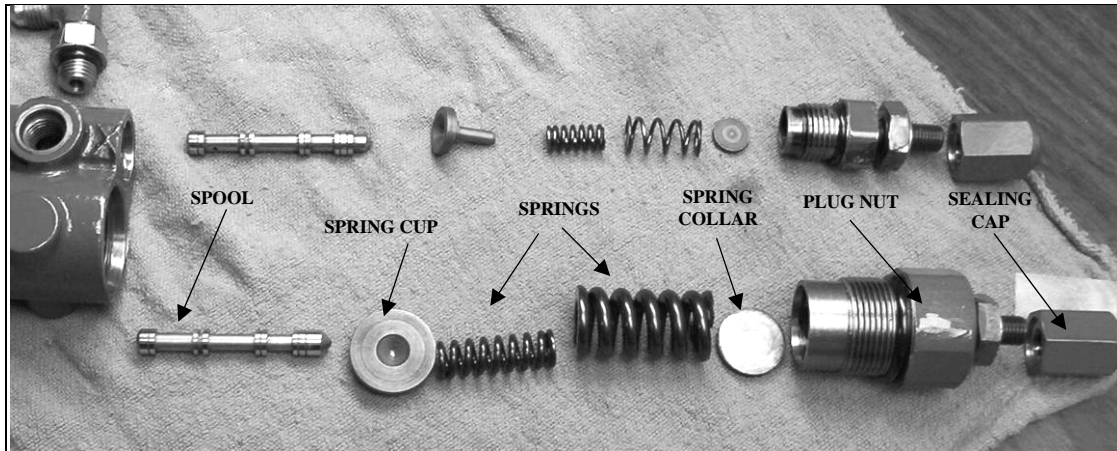

Severe injury can result if the machine is not properly locked out. Observe electrical Lockout/Tagout procedures before performing maintenance on the system components.

Ensure all pressure is relieved or blocked from the hydraulic and high pressure circuits before performing maintenance.

1. Remove the hydraulic hose from the low limit compensator.
2. Remove the four socket screws that attach the compensators to the pump.
3. Remove the compensators and then remove the three plugs and o-rings on the back of the housing.

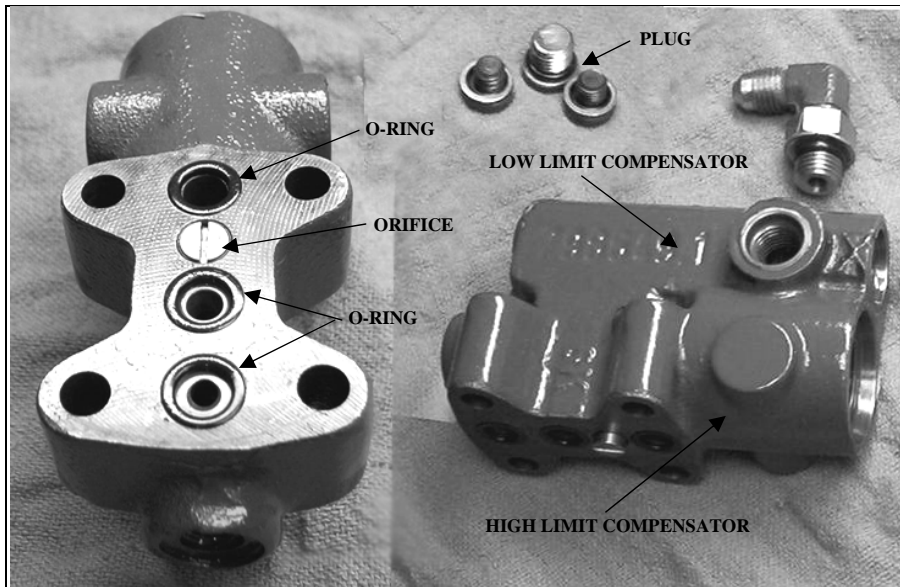

4. Disassemble the compensators one at a time by first removing the hexagon sealing cap.
5. Loosen the lock nut, and then remove the plug nut.
6. Disassemble the plug by removing the spring collar, springs, spring cup and spool.
7. Clean the housing and all components with clean fluid and carefully dry with air.
8. Check and clean the small internal passages in the spools.
9. Check and clean the orifices in both spools.
10. Assemble in the reverse order, ensuring that the screw slot on the orifice is aligned with the long axis of the body.



When the compensators are removed, the machine loses adjustment. The compensators must be reset before operation can begin.

11. Start the machine and select the low pressure operating mode on the display panel.
12. Deadhead the machine.

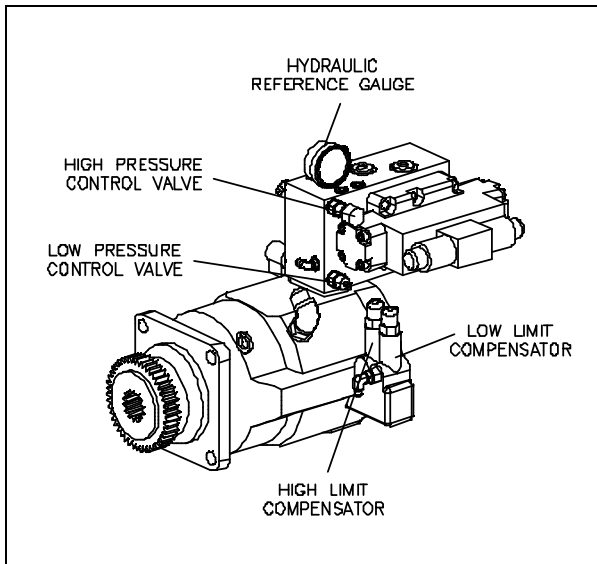

13. Set the high and low pressure control valves on the hydraulic manifold to the minimum setting by turning them counter-clockwise.

If the machine is equipped with proportional pressure control, adjust the high pressure setting on the Pressure Control Screen.

14. Set the compensators to the minimum setting by turning the adjusting screws counter-clockwise.
15. Select high pressure operating mode on the display panel and set the high pressure control valve on the hydraulic manifold to the maximum setting by turning the knob clockwise.
If the machine is equipped with proportional pressure control, adjust the high pressure setting on the Pressure Control Screen.
16. Turn the adjusting screw on the high limit compensator clockwise until the hydraulic reference gauge reads 3,000 psi (207 bar) for 30, 50, 60 and 100D models, or 2,600 psi (179 bar) for 75 and 100 models.
17. Select low pressure operating mode on the display panel and turn the adjusting screw on the low limit compensator clockwise until the reference gauge reads 290 psi (20 bar). Lock the adjustment screw in place.
18. Select high pressure operating mode on the display panel and turn the knob on the high pressure control valve counter-clockwise until the reference gauge reads 2,000 psi (138 bar).

If the machine is equipped with proportional pressure control, adjust the high pressure setting on the Pressure Control Screen.

19. Open the high pressure water control valve, allowing water to flow. Set the desired high operating pressure by adjusting the high pressure control valve.

If the machine is equipped with proportional pressure control, select the high operating pressure on the Pressure Control Screen.

20. While the machine is running and high pressure water is flowing, select low pressure operating mode. Set the desired low operating pressure by adjusting the low pressure control valve.

Hydraulic Pump or Electric Motor Replacement

The following procedures are used to replace the hydraulic pump or the electric motor.

Hydraulic Pump Replacement

1. Turn the machine off and observe the appropriate Lockout/Tagout procedures.



Severe injury can result if the machine is not properly locked out. Observe electrical Lockout/Tagout procedures before proceeding.

Ensure all pressure is relieved or blocked from the hydraulic and high pressure circuits before proceeding.

2. Loosen the hold down screws on the proximity switches to allow the hydraulic oil in the cylinders and hoses to drain back to the reservoir. It will take approximately five minutes for the oil to drain.
3. Drain the oil reservoir by connecting the inlet hose from an oil transfer pump to the drain valve on the reservoir. Open the shut off valve on the drain and pump the used oil out to a container. Close the shut off valve and remove the inlet hose from the drain valve.



The removed oil should not be reused. It is recommended that the empty reservoir be flushed with a few gallons of clean oil to remove settled debris from the bottom of the reservoir.

Figure 7-8: Hydraulic Reservoir

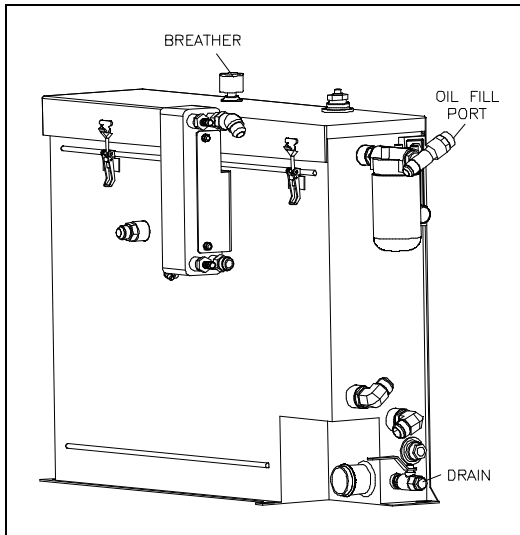

4. Disconnect all hydraulic hoses and connections to the case drain, hydraulic pump, hydraulic manifold and recirculation pump.
5. Loosen the hydraulic gauge and turn it out of the way. Remove all electrical sensors and connections to the hydraulic manifold.
6. Remove the four bolts on the top of the hydraulic manifold and remove the manifold and o-ring.
7. Remove the booster pump, adapter and recirculation pump. These components can be removed individually or as a unit by removing the two bolts that attach the recirculation pump to the hydraulic pump.

Figure 7-9: Component Removal

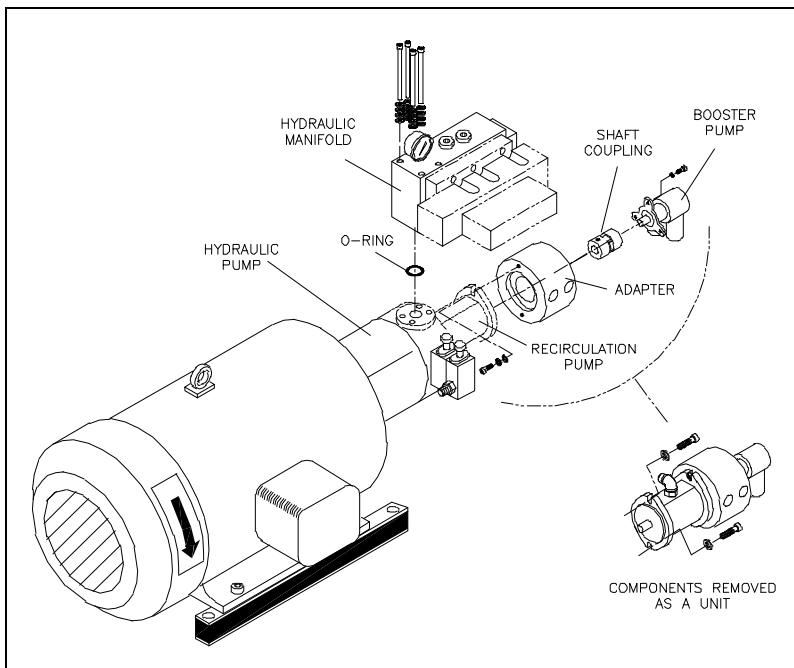

8. Remove the bolts that attach the hydraulic pump to the electric motor.
9. Support the hydraulic pump and slide it away from the motor, disengaging the flexible coupling.
10. Inspect the flexible coupling for damage. If the flexible coupling is damaged it must be replaced.
11. Inspect the metal splines on the motor coupling half. Wipe any residue, dirt or oil from the motor coupling and the flexible coupling. Place the flexible coupling on the motor coupling half, pushing it on as far as it will go.
12. Take a measurement from the front face of the electric motor, the pump mounting interface, to the outer face of the snap ring or solid band on the flexible coupling, dimension A.

Figure 7-10: Pump Coupling Dimensions

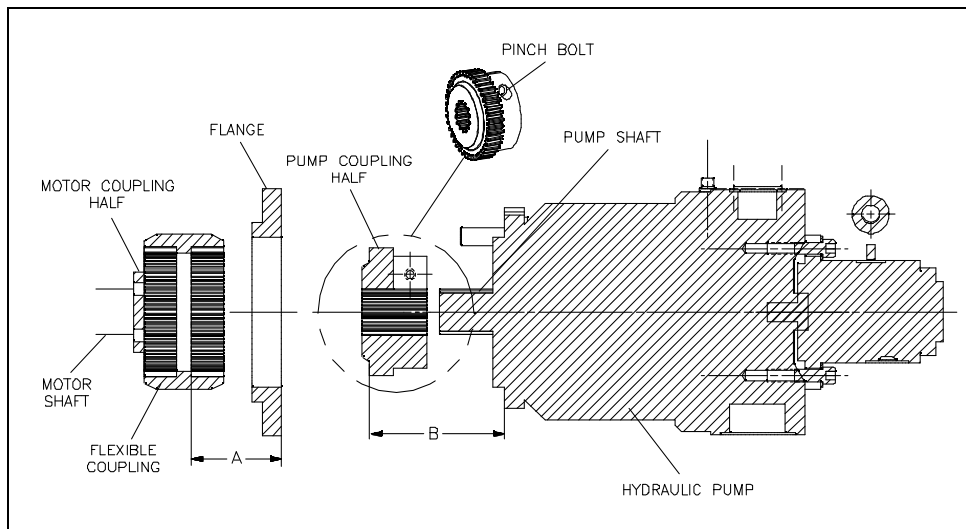

From dimension A, subtract 5/16 inch for 30, 50 and 60 horsepower motors, and 1/4 inch for 75 and 100 horsepower motors.

13. Loosen the pinch bolt in the pump coupling half on the old pump and remove the coupling half. Inspect the metal splines for damage. If the coupling half is not damaged it can be reused on the new pump.
14. Wipe any residue, dirt or oil from the pump coupling half. Slide the existing coupling half, or a new coupling half if necessary, onto the splined shaft of the new pump.
15. Set the position of the pump coupling half by measuring from the pump mounting face to the outer face of the coupling teeth, dimension B. On 30, 50 and 60 horsepower models, $B = (A - 0.313)$, on 75 and 100 horsepower models $B = (A - 0.250)$.
16. Tighten the pinch bolt and torque to 36 ft-lbs (49 Nm) for 30 horsepower models, 63 ft-lbs (86 Nm) for 50 and 60 horsepower models, and 218 ft-lbs (295 Nm) for 75 and 100 horsepower models.
17. Place the hydraulic pump on the motor, ensuring the coupling teeth mesh into the flexible coupling. Force should not be required.

18. Verify that the mating surfaces of the motor and pump meet without resistance from the coupling.
19. Replace the pump mounting bolts and torque to the specifications in Table 7-3, Torque Specifications.
20. Install the recirculation pump, adapter and booster pump.
21. Install the hydraulic manifold ensuring that the o-ring is properly positioned. Torque the mounting bolts to the specifications in Table 7-2.
22. Reconnect all hydraulic hoses, connections and electrical sensors.
23. Tighten the hold down screws on the proximity switches and torque to 140-160 in-lbs (16-18 Nm).



Ensure that the proximity switches are properly installed and secured prior to starting the motor. Failure to tighten the two hold down screws on each switch will result in the spray of hydraulic oil.

24. Refill the hydraulic reservoir following the procedure, Hydraulic Oil Replacement.
25. Start the motor and apply full high pressure water pressure. Inspect for hydraulic leaks and note any unusual sounds from the motor or pump assembly.

Table 7-2
Torque Specifications

	30 HP	50 and 60 HP	75 and 100 HP
Pump mounting bolts	55 ft-lb (75 Nm)	110 ft-lb (149 Nm)	200 ft-lb (271 Nm)
Manifold mounting bolts	35 ft-lb (47 Nm)	35 ft-lb (47 Nm)	45 ft-lb (61 Nm)
Motor coupling half bolts	36 ft-lb (49 Nm)	36 ft-lb (49 Nm)	85 ft-lb (115 Nm)

Electric Motor Replacement

1. Complete Steps 1-10 in the previous procedure.
2. Open the junction box on the motor and remove all electrical leads. Loosen the lock nut, disconnect and remove the flexible electrical cable from the junction box.
3. Remove the bolts attaching the motor to the vibration isolation mounts and remove the old motor from the frame.
4. Stand the new motor on the fan cowl with the shaft pointing upward.

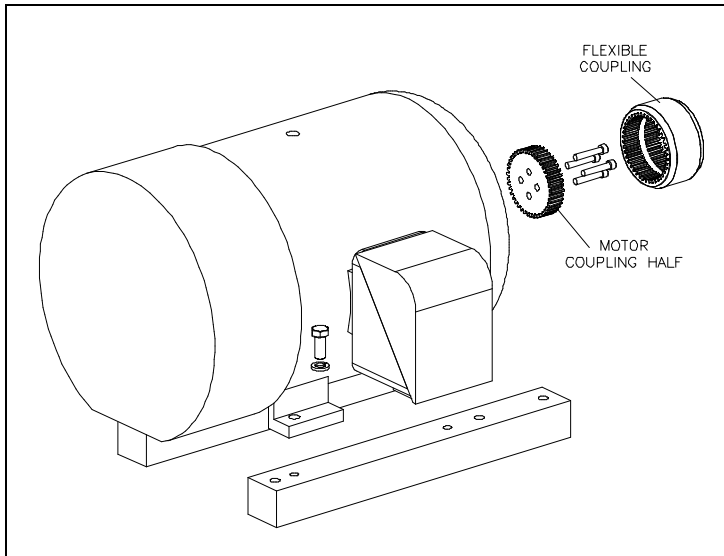
Figure 7-11: Motor Coupling Half

5. Apply Loctite 222 to the bolts and attach a new motor coupling half to the motor shaft. Torque to the specifications in Table 7-3.
6. Place the flexible coupling on the motor coupling half. Follow Step 12 and 14 in the previous procedure to determine if the coupling half on the hydraulic pump is in the proper position. If necessary, adjust the position of the pump coupling half.
7. Place the hydraulic pump on the motor, ensuring the coupling teeth mesh into the flexible coupling. Force should not be required.
8. Verify that the mating surfaces of the motor and pump meet without resistance from the coupling.
9. Replace the pump mounting bolts and torque to the specifications in Table 7-3.
10. Position the motor and hydraulic pump in the frame. Attach the motor to the vibration isolation mounts.
11. Install the flexible electrical cable on the junction box and replace the electrical leads.
12. Complete Steps 19-24 in the previous procedure.

Hydraulic Oil Replacement

Hydraulic oil **must only** be replaced at the fill port on the filter head.

1. Remove the cap from the fill port on the oil filter.



To ensure cleanliness, the oil fill port **must** be used to pump oil into the reservoir. Filling at this point guarantees the hydraulic oil will pass through the oil filter before entering the reservoir.

2. Connect the discharge hose from an oil transfer pump to the fill port and pump the fresh oil into the reservoir.

NOTE

Oil from a new drum does not meet the cleanliness requirements of the hydraulic system. For this reason, it is important to use an oil transfer pump that will force oil through the return filter into the reservoir.

3. Check the oil sight gauge on the reservoir to ensure proper fill level.
4. Remove the hose from the case drain on the main hydraulic pump to make sure the pump case fills with oil. With the hose removed, head pressure from the reservoir will force oil into the pump case.



Oil in the pump case provides internal lubrication for the main hydraulic pump. Failure to fill the pump case with oil will allow air to become trapped inside, damaging the pump.

5. Disconnect the discharge hose from the fill port and replace the fill port cap.
6. Follow the initial startup sequence in Section 4, Operation, to ensure the system fills with oil.
7. Check the sight gauge again and follow the same procedure to add additional oil if necessary.

Electric Motor Bump

Bumping is defined as allowing the electric motor to start rotating, but stopping it before the motor gets up to full speed.

Whenever the hydraulic reservoir is emptied or the hydraulic pump has been changed, bumping the electric motor is suggested. This procedure will ensure the hydraulic pump is full of oil and deter cavitation which will cause the hydraulic pump to fail prematurely.

Do not perform this procedure until the correct motor rotation and the presence of hydraulic oil in the hydraulic pump case drain line has been confirmed.

1. Start the pump in recirculation mode, count two seconds and turn the pump off.
2. Repeat this process six times before allowing the hydraulic pump to create pressure.



SECTION 8

ELECTRICAL SYSTEM

8.1 Overview

All SL-V *Plus* models are equipped with integral motor starter and control circuitry, enclosed in the electrical panel. The operator controls the machine primarily through a touch-screen control panel that communicates with the programmable logic controller (PLC). A series of sensors provide automatic shutdown logic and diagnostics.

Major system components include the electric motor, control panel, high voltage and control components, and the wiring harness that connects the sensors and solenoid valves to the PLC.

8.2 Optional System Components

The following system options are available at the time of purchase, or as upgrade kits for existing equipment.

- A pressure transducer allows the operating pressure to be viewed from the display panel.
- Proportional pressure control allows the operator to select or vary the hydraulic operating pressure from the control panel or from a remote console.
- A modem option permits remote monitoring for troubleshooting and software updates.
- A 37-pin amphenol connector, mounted in the side of the electrical enclosure, is available for all remote connections.

8.3 Operation

Electrical power from the utility grid enters the main circuit breaker/disconnect on the electrical enclosure door as 3-phase alternating current. The power is then distributed in two directions. The 3-phase AC, at the voltage provided from the grid, is routed to the motor starter contactor(s) and then to the main motor. Single phase AC is routed to the transformer.

Figure 8-1: Electrical Control Power

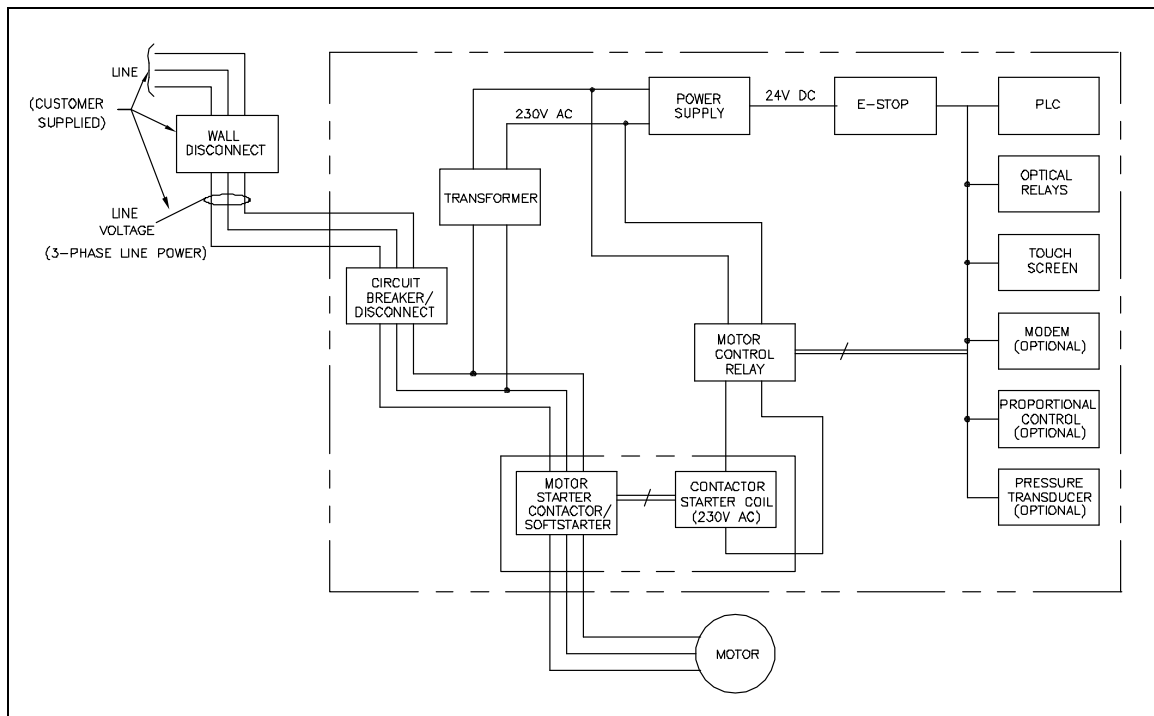

The multi-tap transformer converts the incoming voltage to 230 volt AC that is routed to both the motor starter contactor(s) and to the power supply. The power supply then provides 24 volt direct current to the control circuits, including the emergency stop logic, the Programmable Logic Controller (PLC), optical relays, display screen and optional control functions.

When the start button is pressed on the control panel, the motor control relay closes and 230 volt AC power is sent to the contactor coil(s). The coil(s) close, sending the incoming power to the motor. When the stop button is pressed, the motor control relay opens, disconnecting power to the contactor coil(s), stopping the motor.

The motor is started by either contactors or a softstarter, solenoid operated by 230 volt AC control power.

Contactors are arranged in either a wye-delta or an across-the-line starter circuit. Wye-delta starter circuits are typically installed in all low voltage, high horsepower machines that require high current draw. Three, 3-phase contactors are used to start the motor slowly, minimizing the initial current draw. Across-the-line or full-voltage starting requires a single 3-phase contactor and is used on high voltage machines with low current draw.

Softstarters combine contactors, overload, timers and internal power/control wiring into a single device. They utilize a current limit starting method to greatly reduce mechanical and electrical shock to the system.

Figure 8-2: Wye-Delta Configuration

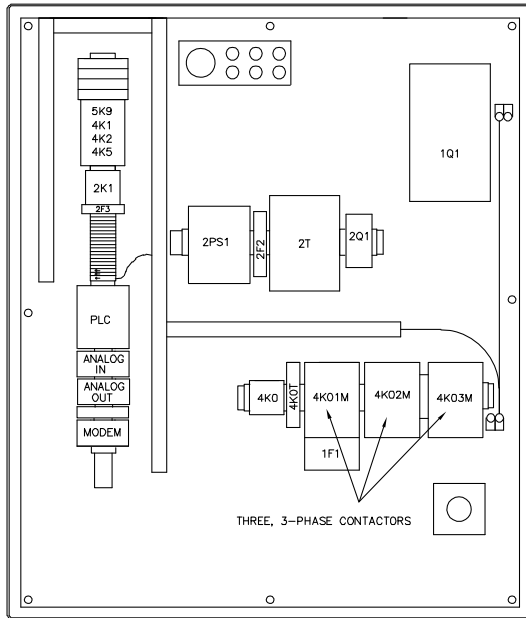

Figure 8-3: Across-the-Line Configuration

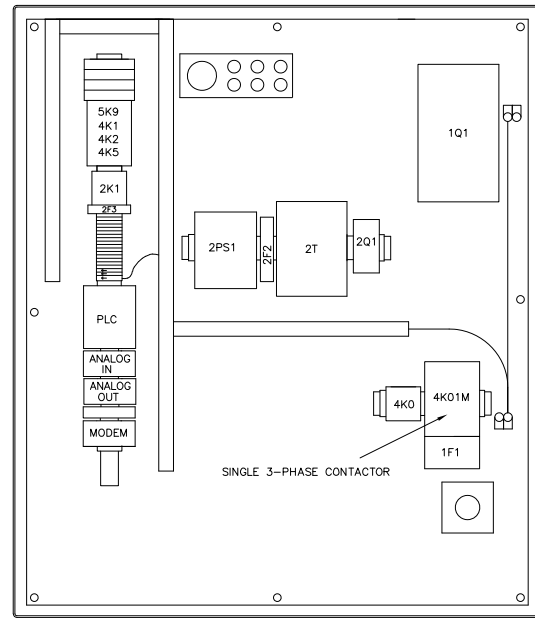
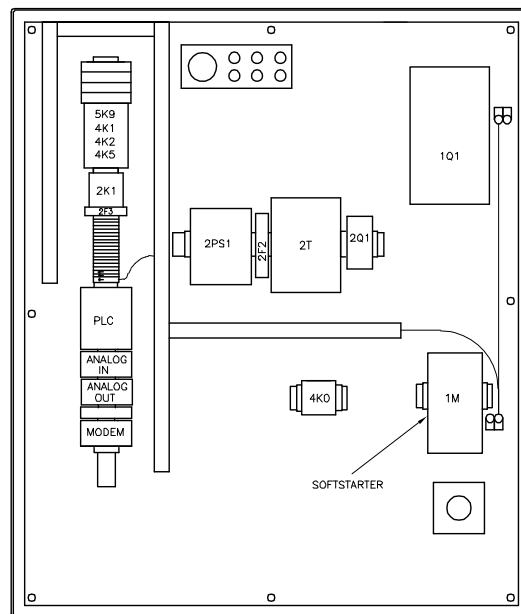
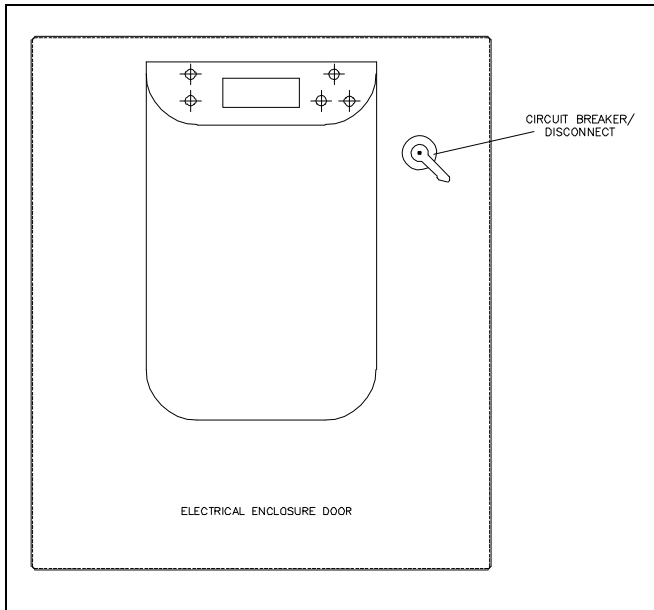

Figure 8-4: Softstart Configuration



The circuit breaker/door disconnect provides the primary over current protection for the machine. All power is automatically disconnected from the machine when the main disconnect on the enclosure door is opened. However, power is still present on the input side of the circuit breaker/door disconnect. The only way to isolate all power to the machine is to turn the customer installed main power disconnect off.

Figure 8-5: Electrical Enclosure Door



NOTE

See Section 2, Installation, regarding specifications for the customer installed main power disconnect.

Sensors and Solenoids

Warning and shutdown sensors monitor operating conditions, and electronically operated solenoids provide basic intensifier shift control. The harness cable connects these sensors and solenoids to the PLC.

Figure 8-6: Sensors and Solenoids

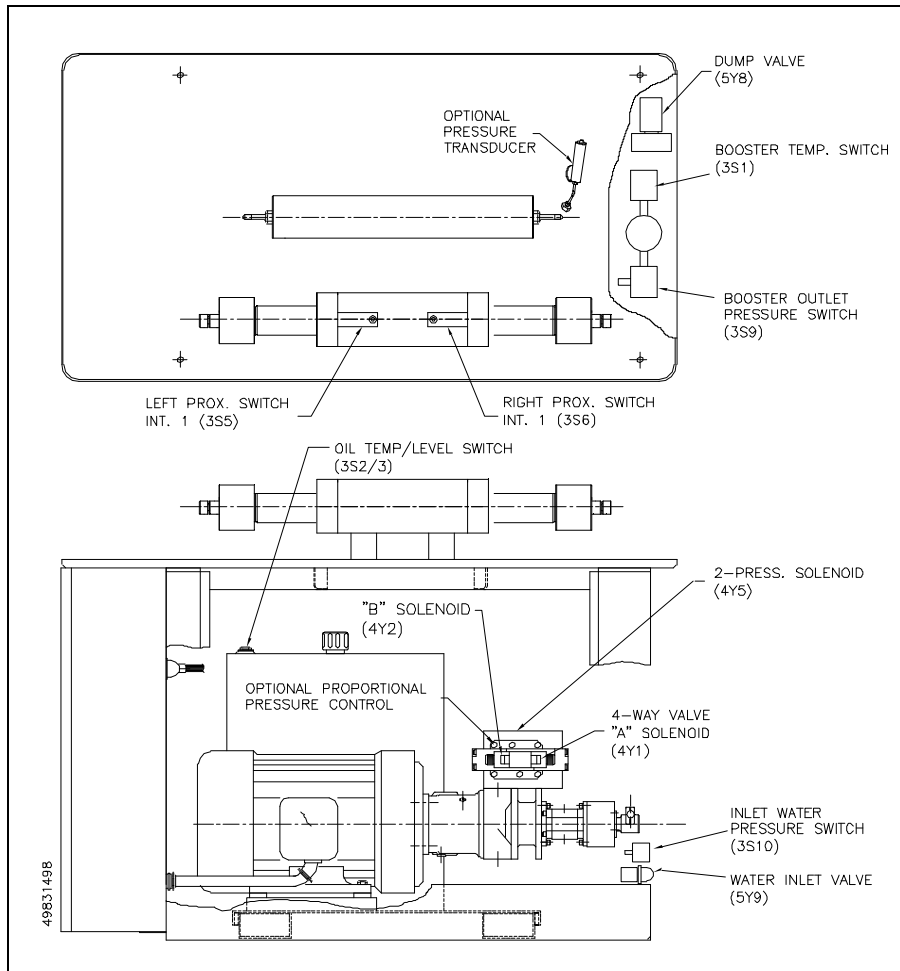

Table 8-1
Sensors and Solenoids

Component	Function
<p>Inlet Water Solenoid Valve</p> 	<p>1 The normally closed, inlet water solenoid valve is located at the service bulkhead. When the control power is turned on, the valve opens and allows low pressure cutting water to enter. The solenoid valve functions as a safeguard by closing if a leak is detected anywhere in the system, or if the system is idle for an extended period.</p> <p>The operator can adjust the idle closing time from 5 to 60 minutes. The function can also be disabled so the valve stays open whenever the control power is on.</p>
<p>Low Pressure Water Filter Assembly</p> 	<p>2 The 30 psi pressure switch, mounted on the inlet manifold, monitors the inlet cutting water. If the pressure drops below 30 psi (2 bar) the switch activates an automatic shutdown circuit, protecting the booster pump from damage due to insufficient water supply pressure.</p> <p>3 A temperature switch monitors the temperature of the cutting water from the booster pump. If the temperature exceeds 128° F (53° C), the switch activates an automatic shutdown circuit in the PLC. The temperature switch prevents booster pump overheating due to lack of water, long deadhead conditions or a blocked orifice.</p> <p>4 To ensure adequate water pressure and supply to the intensifiers, the discharge pressure is monitored by a 60 psi pressure switch. An automatic shutdown occurs if the pressure is below 60 psi (4 bar).</p>

Table 8-1
Sensors and Solenoids

Component	Function
<p>Hydraulic Reservoir</p> 	<p>5 The temperature/low level switch monitors the oil temperature and level in the reservoir. Although the float switch and the temperature switch are combined in a single unit, the two switches function independently.</p> <p>If the operating oil temperature exceeds 144° F (62° C) an automatic shutdown occurs. If the hydraulic fluid level falls below specifications, a low oil level shutdown occurs.</p> <p>6 Models equipped with an air cooler utilize a temperature switch to regulate oil temperature.</p>
<p>Hydraulic Manifold</p> 	<p>7 The 4-way directional control valve shifts the hydraulics back and forth to the intensifier. A shift valve directs pressurized oil to one end of the hydraulic cylinder and returns fluid to the reservoir from the opposite end, causing the intensifier to stroke. The movement is controlled hydraulically by a pilot valve that is electronically operated by two solenoids, energized by the PLC. As power is directed from one solenoid to the other, LEDs are alternately illuminated.</p> <p>8 When low pressure is selected, a normally closed, solenoid valve is activated. The valve remains closed while operating in high pressure and is held open electrically during low pressure operation. An illuminated LED on the solenoid indicates low pressure operation.</p>

Table 8-1
Sensors and Solenoids

Component	Function
<p>Hydraulic Cylinder</p> 	<p>9 As pressurized hydraulic oil is sent to one side of the hydraulic cylinder, it pushes against the piston, moving it in one direction until it activates the proximity switch at the end of the stroke. The hydraulic flow is then sent to the opposite side of the cylinder, and the piston reverses direction until it activates the proximity switch at the opposite end of the stroke.</p> <p>The green light on the proximity switch indicates there is power to the switch. The light turns red when the switch is activated. The proximity switches are magnetically activated by the presence of the metallic surface of the piston. When the switch is activated, it sends a signal to the PLC to change the flow of the directional control valve and reverse direction.</p>
<p>High Pressure Safety Dump Valve</p> 	<p>10 When control power is removed, the safety dump valve releases the stored pressure in the intensifier and high pressure delivery lines. The high pressure dump valve assembly includes a normally open high pressure water valve and a solenoid operated air valve.</p> <p>The normally open pneumatic dump valve is held closed by air pressure. When the air supply is interrupted from an emergency stop, the valve opens and allows water to flow through the valve. Pressure is released in the intensifier and the high pressure water stream exits through the drain.</p>
<p>Proportional Pressure Control</p> 	<p>11 Optional proportional pressure control allows the operator to select or vary the hydraulic operating pressure from the control panel or from a remote console. An electronically controlled hydraulic cartridge valve, mounted on the hydraulic manifold, receives a signal from the PLC and automatically makes the operator selected adjustments.</p>

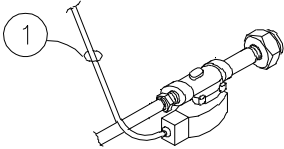
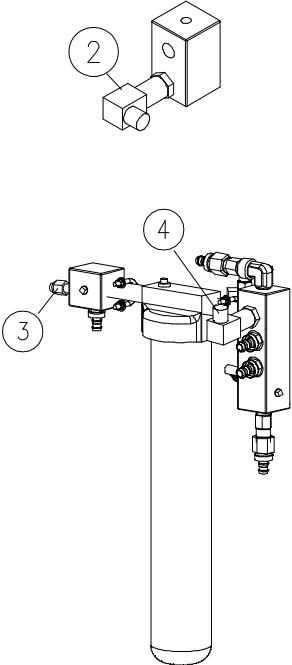
Table 8-1
Sensors and Solenoids

Component	Function
<p>Pressure Transducer</p> 	<p>The optional pressure transducer reads the output pressure from the attenuator in the high pressure system. A signal is sent to the PLC module that allows the operating pressure to be viewed from the control panel.</p>

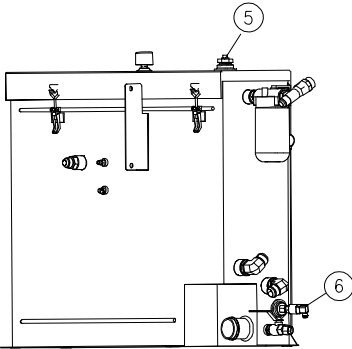
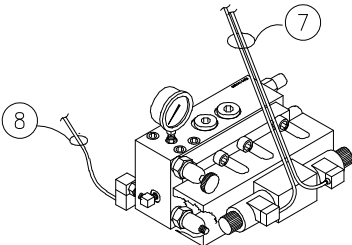
Softstarter

The softstarter is a reduced voltage starter that minimizes system mechanical and electrical stress by reducing current surges. A run/fault LED display relays device status information and fault diagnostics. A flashing red LED indicates a fault, either internal to the softstarter, or with the incoming power or motor. The number of flashes in sequence, indicates the fault, see Section 10, Troubleshooting.

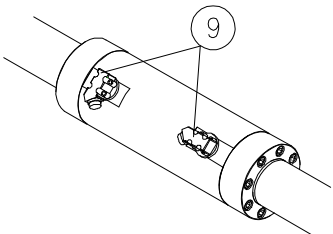
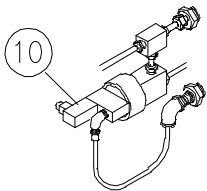
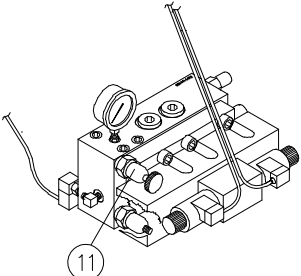
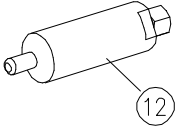
NOTE

The blue arrow selector above the LED display is the setting for full load amps.
The arrow must be set at the FLA for the motor.

Dip Switch Settings

DIP switches are used to set the start/stop profile, overload trip class and auxiliary contact characteristics. Open the tab on the top, right of the softstarter to access the eight DIP switches. Table 8-2 illustrates the switch settings, starting from the left.

Table 8-2
DIP Switch Settings

Number	Setting	Position
1	Start time (2 seconds)	Down
2	Start time (2 seconds)	Down
3	Soft Start	Up
4	Current limit above Full Load Amps (250%)	Down
5	Current limit above Full Load Amps (250%)	Up
6	Soft Stop	Down
7	Soft Stop	Down
8	Start Time	Down
9	Kick Start (450%)	Down
10	Kick Start (450%)	Down
11	Trip Class	Up
12	Trip Class	Down
13	Overload Reset (Auto)	Up
14	Aux (Normal)	Down
15	Lone or Delta (Delta)	Down
16	Phase Rotation (Disabled)	Up

8.4 Service and Maintenance Procedures

Electrical components require minimal service. The proximity switches on the hydraulic cylinder and the optical relay switches in the controls subassembly may require replacement.

NOTE

Refer to Section 12, Parts List for a complete listing of replacement parts and part numbers.

Proximity Switch Maintenance

A proximity switch has failed and needs to be replaced if the LEDs do not change state, indicating they are not sensing the piston, if an LED flashes continuously, or if the appropriate input is not noted on the PLC processor annunciator light panel in the electrical enclosure.

Figure 8-7: Proximity Switch

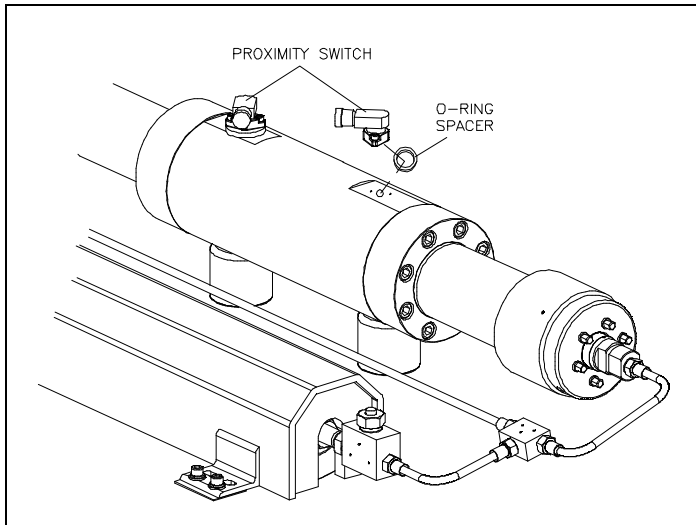

1. Turn the machine off and observe the appropriate Lockout/Tagout procedures.



Severe injury can result if the machine is not properly locked out. Observe electrical Lockout/Tagout procedures before performing maintenance on the system components.

Ensure all pressure is relieved or blocked from the hydraulic and high pressure circuits before performing maintenance.

2. Remove the electrical cable from the failed proximity switch.
3. Remove the two socket head screws, the failed switch and the o-ring spacer.
4. Install a new proximity switch by positioning the o-ring spacer and the switch. Ensure the o-rings are correctly oriented.
5. Apply JL-M grease to the threads on the screws and tighten to 140-160 in-lbs (16-18 Nm).



Ensure that the proximity switch is properly installed and secured prior to starting the machine. Failure to tighten the two hold down screws on each switch will result in the spray of hydraulic oil.

Optical Relay Maintenance

The four optical relays identified in Table 8-3 change the state of the associated solenoid valves. If the relay or the fuse for the relay fails, the state will not change. For example, if the relay controlling the two-pressure solenoid valve fails, the machine will not switch between low and high pressure operation.

Table 8-3
Optical Relays

Label	Component	Function
4K1	Directional Control Valve, Solenoid A	Switches the direction of the hydraulic flow
4K2	Directional Control Valve, Solenoid B	Switches the direction of the hydraulic flow
4K5	Two Pressure Solenoid Valve	Switches to low or high pressure operation
5K9	Water Supply Valve	Opens and closes the inlet water solenoid valve

Figure 8-8: Optical Relays

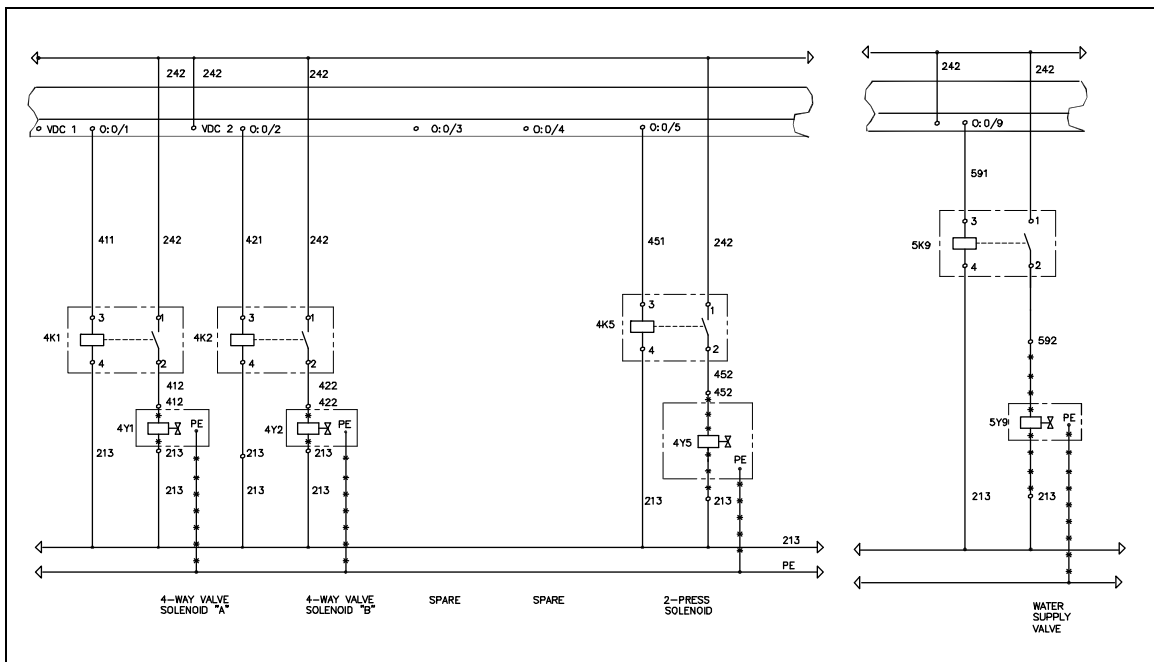

1. Turn the machine off and observe the appropriate Lockout/Tagout procedures.



Severe injury can result if the machine is not properly locked out. Observe electrical Lockout/Tagout procedures before performing maintenance on the system components.

Ensure all pressure is relieved or blocked from the hydraulic and high pressure circuits before performing maintenance.

2. Open the control panel and locate the appropriate optical relay.
3. Remove the screws and the relay.
4. Remove and test the fuse. If the fuse has failed, replace it and re-install the existing optical relay.
5. If the fuse is good, replace the optical relay.



SECTION 9

HIGH PRESSURE WATER SYSTEM

9.1 Overview

The high pressure water system is supported by both the cutting water supply circuit and the hydraulic circuit. Cutting water of sufficient flow and pressure is routed from the cutting water supply circuit to the intensifier where it is pressurized up to 60,000 psi (4,137 bar) and delivered to the cutting head.

The directional control valve in the hydraulic system creates the stroking action of the intensifier by sending pressurized hydraulic oil to one side of the hydraulic cylinder or the other. As the flow is sent to one side, hydraulic fluid is returned to the reservoir from the opposite side.

Figure 9-1: High Pressure Water System Circuit

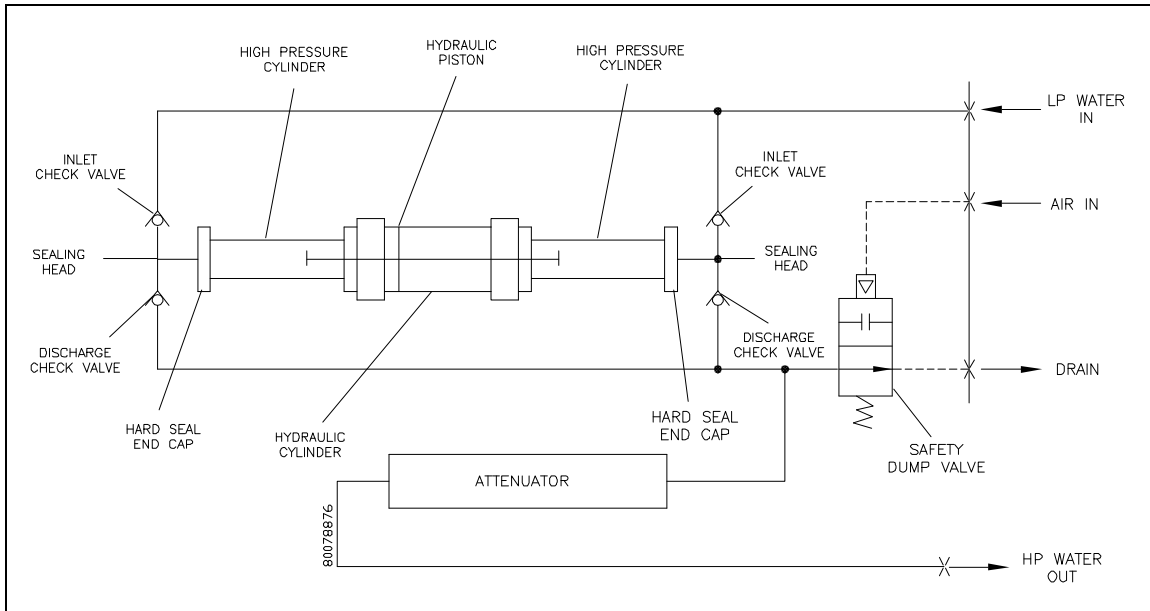

System components include a double-ended hydraulic cylinder; reciprocating piston assembly; high pressure cylinders attached to each end of the hydraulic cylinder; two plungers, sealing heads and hard seal end caps; one or two liter capacity attenuators, and a safety dump valve. Sophisticated check valves and seal assemblies ensure hydraulic oil, and the low pressure and high pressure water travel in the appropriate direction. Warning and shutdown sensors monitor strategic pressure, temperature and fluid levels to safeguard against component damage.

9.2 System Options

The following system options are available at the time of purchase, or as upgrade kits for existing equipment.

- A redundant intensifier allows operation to continue if a problem is detected on the active intensifier. Operation can be switched to the secondary intensifier until the next convenient shutdown, when service can be performed on the primary intensifier.
- A two liter attenuator is available for 30 and 50 horsepower models. Two liter attenuators are standard on 60, 75 and 100 horsepower models.

9.3 Operation

The directional control valve sends pressurized hydraulic oil to one side of the hydraulic cylinder. The pressurized oil pushes against the piston, moving it in one direction until it activates the proximity switch at the end of the stroke. The hydraulic flow is then sent to the opposite side of the cylinder, and the piston reverses direction until it activates the proximity switch at the opposite end of the stroke.

Figure 9-2: High Pressure Water System

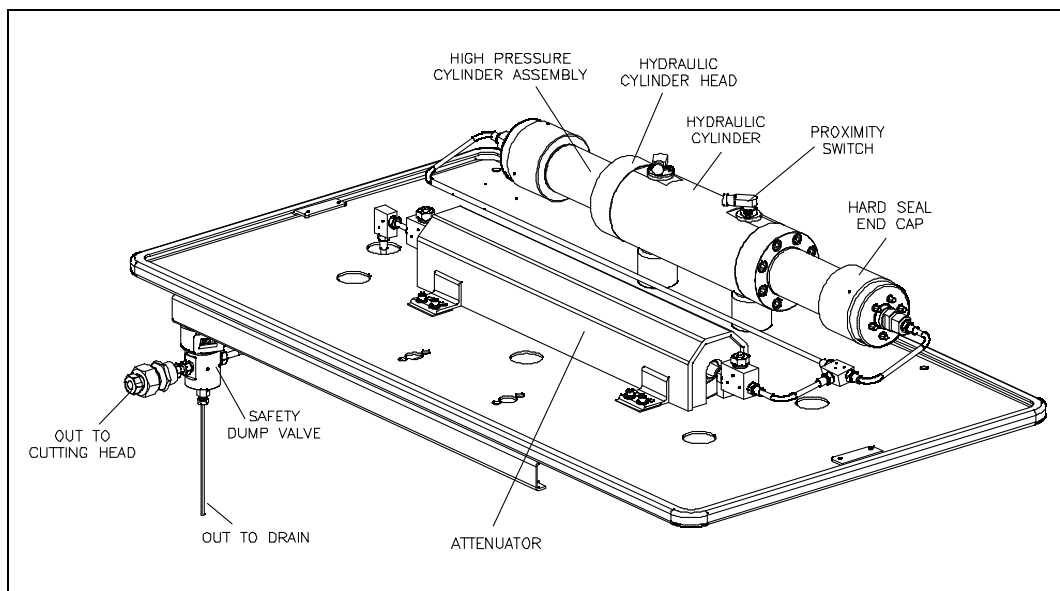

The green light on the proximity switch indicates there is power to the switch. The red light illuminates when the switch is activated. The proximity switches are magnetically activated by the presence of the metallic surface of the piston. When the switch is activated, it sends a signal to the PLC to change the flow of the directional control valve and reverse direction.

As the pressurized oil pushes the piston in one direction, the plunger on that end extends and pushes against the water in the high pressure cylinder, increasing the pressure up to 60,000 psi (4,137 bar). When the piston reverses direction, the plunger retracts and the plunger in the opposite cylinder extends to deliver the high pressure water.

Figure 9-3: High Pressure Cylinder

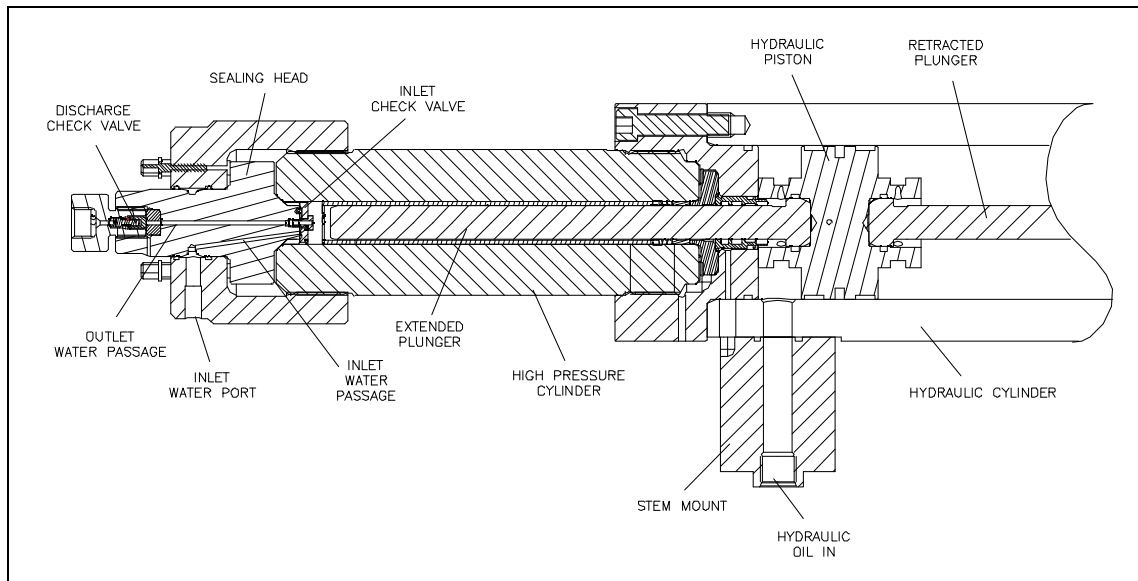

Low pressure water is routed through the inlet water ports to the inlet passages in the sealing heads. When the plunger retracts, the inlet check valve opens to allow water to fill the high pressure cylinder. When the plunger extends to create high pressure water, the inlet valve closes to seal the inlet passage and the discharge check valve opens to allow the high pressure water to exit the cylinder. As the plunger retracts, the discharge check valve closes.

The intensifier is a reciprocating pump. As the piston and plungers move from one side to the other, high pressure water exits one side of the intensifier as low pressure water fills the opposite side.

The high pressure water is then routed to the attenuator. The attenuator acts as a shock absorber to dampen pressure fluctuations and ensure a steady and consistent supply of water. From the attenuator, the high pressure water exits to the cutting head.

The safety dump valve releases the stored pressure in the intensifier and high pressure delivery lines. The high pressure dump valve assembly includes a normally open high pressure water valve and an electrically controlled air valve.

The normally open pneumatic dump valve is held closed by air pressure. When the air supply is interrupted and exhausted from an emergency stop, the valve opens and allows water to flow through the valve. Pressure is released in the intensifier and the high pressure water stream exits through the drain.

Redundant Intensifiers

If the machine is equipped with redundant intensifiers, the cutting water supply lines are manually connected to the inlet water ports on the active intensifier. Manual hydraulic valves are opened or closed to direct the hydraulic flow to the active intensifier. Manual high pressure water valves are also opened or closed to direct the high pressure water flow from the active intensifier. Control is switched from one intensifier to the other from the Run Screen on the control panel.



When a machine is equipped with redundant intensifiers, operation can continue on the secondary unit if the primary unit requires maintenance. However, maintenance **must not** be performed while the machine is in operation.

Maintenance **must never** be performed on any high pressure components while the machine is operating. All pressure must be relieved or blocked from the hydraulic and high pressure circuits and the electrical panel must be locked out before performing maintenance.

The following example describes the procedure for changing from one intensifier to the other. In this example, intensifier 2 will become the active intensifier and intensifier 1 will become inactive.

1. Turn the machine off and make sure the emergency stop button is depressed.
2. Turn the cutting water supply off.
3. Disconnect the low pressure water supply lines from intensifier 1 and connect them to intensifier 2.
4. Remove the side cover to gain access to the hydraulic hand valves and close the two hydraulic shutoff valves to intensifier 1.
5. Close the high pressure water shutoff valve to intensifier 1.
6. Open the two hydraulic shutoff valves, and the high pressure water shutoff valve to intensifier 2.
7. Select intensifier 2 from the Run Screen on the control display.
8. Turn the cutting water supply on and ensure all cooling water, water supply and cutting water valves are open.
9. Ensure all hydraulic and high pressure fittings, and the proximity switches are properly tightened on intensifier 2.
10. Start the machine in low pressure mode and inspect the hydraulic, high pressure fittings, valves and hoses for leaks.

Dual Intensifiers

If the machine is equipped with dual intensifiers, cutting water supply lines are connected to the inlet water ports on both intensifiers, and the directional control valve supplies hydraulic pressure to both intensifiers.

9.4 System Components

The following figures illustrate the individual high pressure water system components.

NOTE

System components, specifications, and some maintenance procedures are determined by the horsepower rating and/or plunger diameter. The information in this section is organized and presented accordingly.

Figure 9-4: High Pressure Cylinder Assembly

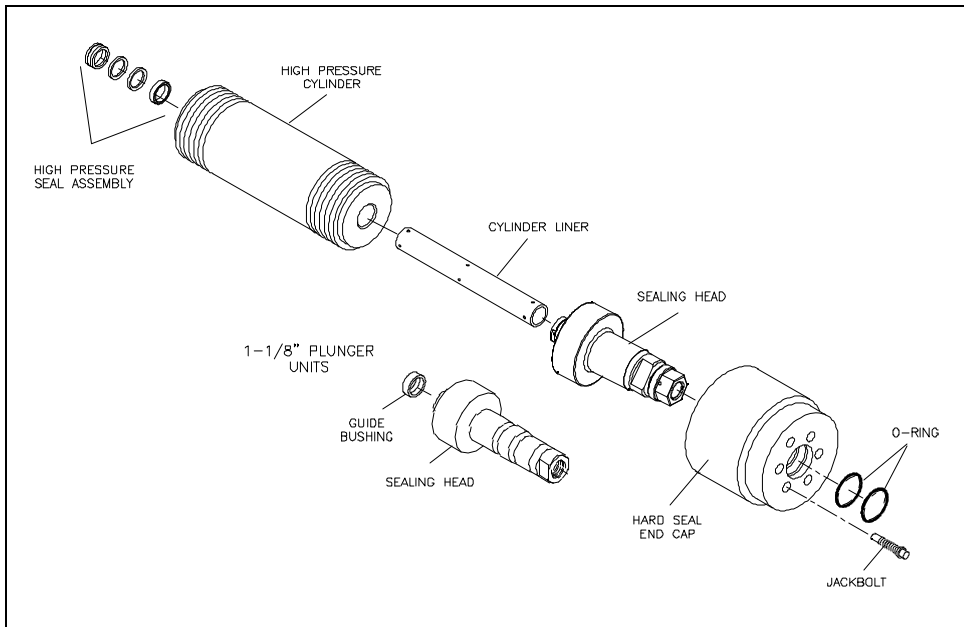

Figure 9-5: Hydraulic Cylinder Assembly

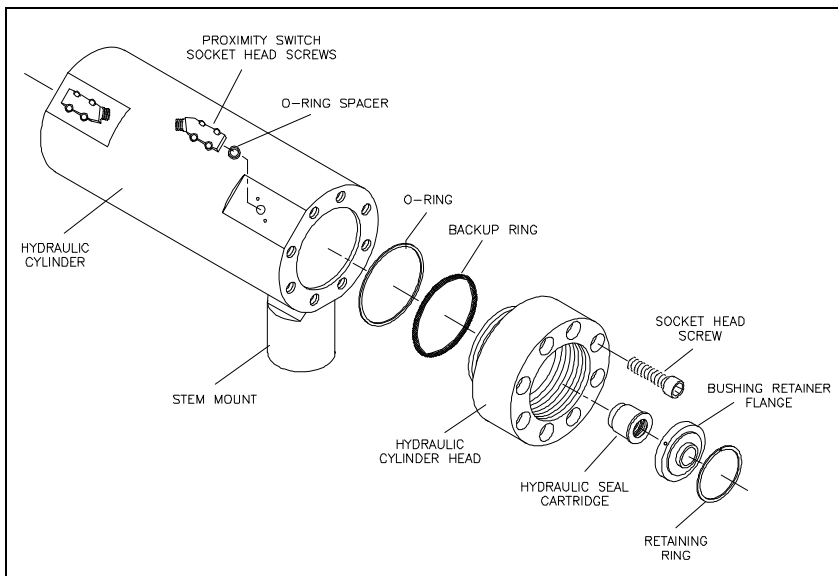
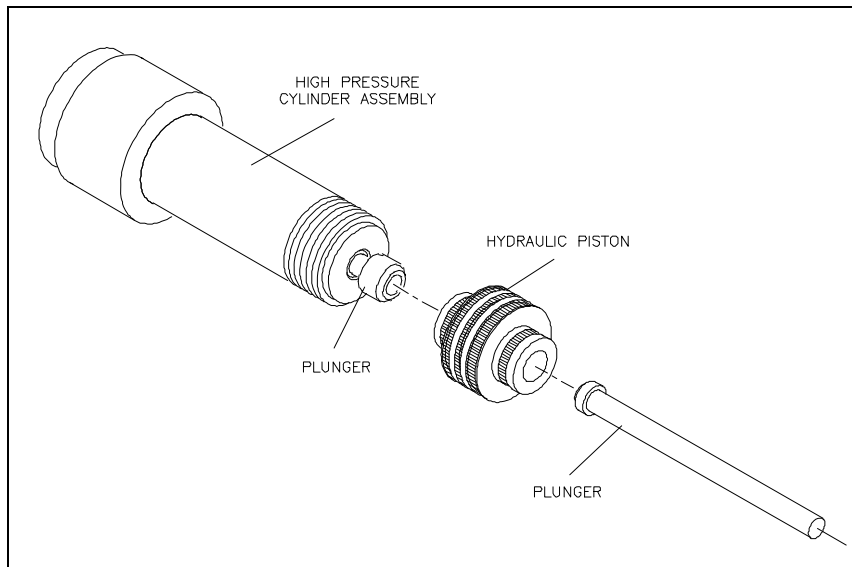

Figure 9-6: Hydraulic Piston

9.5 Service and Maintenance Overview

Never perform any type of maintenance on the high pressure water system while it is pressurized. Always turn the power off and bleed the high pressure water before servicing. Pressing the emergency stop button turns the control power off to the intensifier, and bleeds high pressure water through the dump valve.

Improper assembly can lead to the premature failure of components. Maintenance procedures must be followed carefully; components must be properly cleaned prior to assembly and tightened to the correct torque specifications.

Some high pressure components are not serviceable at the customer level, others require precise refinishing. KMT Waterjet Systems offers maintenance and refinishing services for these components.

NOTE

Refer to Section 12, Parts List for a complete listing of replacement parts and part numbers.

Torque Specifications

Table 9-1, Torque Specifications, details the torque specifications and tightening sequences for the high pressure components and connections.

**Table 9-1
Torque Specifications
High Pressure Water System**

	7/8" Diameter Plunger	1-1/8" Diameter Plunger
Hard Seal End Cap		
Jackbolts	6 (7/16") each	8 (7/16") each
1st Stage	Hand Tight	Hand Tight
2nd Stage	20 ft-lbs (27 Nm) Crossing Pattern*	20 ft-lbs (27 Nm) Crossing Pattern
3rd Stage	32-35 ft-lbs (43-47 Nm)** Crossing Pattern	32-35 ft-lbs (43-47 Nm)* Crossing Pattern
4th Stage	32-35 ft-lbs (43-47 Nm)* Clockwise Pattern From Bolt 1	32-35 ft-lbs (43-47 Nm)* Clockwise Pattern From Bolt 1
Socket Wrench Size	3/8 inch	3/8 inch

6-Bolt Crossing Pattern

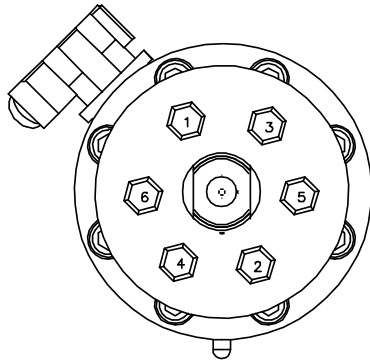

8-Bolt Crossing Pattern

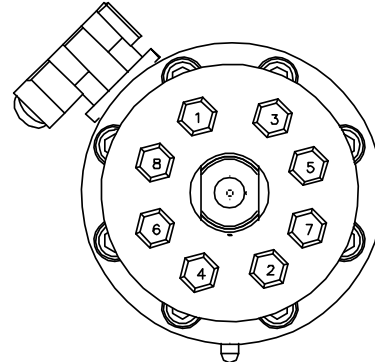

* **Note:** Crossing Pattern: 1, 2, 3, 4, 5, 6 or 1, 2, 3, 4, 5, 6, 7, 8.

** **Note:** A maximum torque of 38 ft-lbs (51 Nm) is etched on the hard seal end cap. This represents the **maximum** allowable torque, not the recommended torque.

Hydraulic Cylinder Head		
Socket Head Screws	8 (M14) each	6 (3/4") each
Torque	75-80 ft-lbs (102-108 Nm)	170-175 ft-lbs (230-237 Nm)
Hex Key	M12	5/8 inch



Table 9-1
Torque Specifications
High Pressure Water System

	7/8" Diameter Plunger	1-1/8" Diameter Plunger
Proximity Switch		
Socket Head Screws	2 (M6) each	2 (1/4") each
Torque	140-160 in-lbs (16-18 Nm)	140-160 in-lbs (16-18 Nm)
Hex Key	M5	3/16 inch
Stem Mount		
Socket Head Screws	4 (M10) each	4 (3/8") each
Torque	60-65 ft-lbs (80-88 Nm)	35-40 ft-lbs (47-54 Nm)
Hex Key	M8	5/16 inch
Sealing Head		
Discharge Gland Nut	130 ft-lbs (176 Nm)	200 ft-lbs (271 Nm)
Poppet Retainer	30 in-lbs (3.4 Nm)	25-30 in-lbs (2.8-3.4 Nm)
3-Port Pneumatic Valve		
HP Adapter	25 ft-lbs (34 Nm)	
1/4-inch Outlet to Drain	25 ft-lbs (34 Nm)	
Pneumatic Actuator	5 ft-lbs (7 Nm)	
3/8-inch HP Gland Nut	50 ft-lbs (68 Nm)	
2-Port Pneumatic Valve		
3/8-inch HP Gland Nut		50 ft-lbs (68 Nm)
1/4-inch HP Gland Nut		25 ft-lbs (34 Nm)
Pneumatic Actuator		5 ft-lbs (7 Nm)
9/16-inch/1/4-inch HP Bushing		50 ft-lbs (68 Nm)
High Pressure Fittings		
1/4-inch HP Gland Nut	25 ft-lbs (34 Nm)	25 ft-lbs (34 Nm)
3/8-inch HP Gland Nut	50 ft-lbs (68 Nm)	50 ft-lbs (68 Nm)
9/16-inch HP Gland Nut	110 ft-lbs (149 Nm)	110 ft-lbs (149 Nm)

Specialized Maintenance Tools

KMT Waterjet has designed tools to facilitate the removal and installation of specialized system components. These tools are illustrated in Figure 9-7, Specialized Maintenance Tools, and part numbers are provided in Table 9-2.

Figure 9-7: Specialized Maintenance Tools

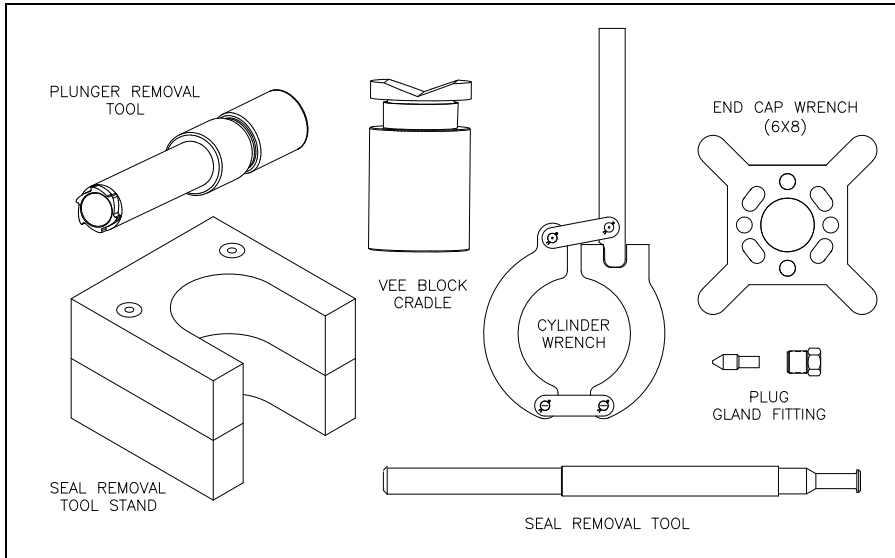

Table 9-2
Specialized Maintenance Tools
High Pressure Water System

	Part Number	
	7/8" Diameter Plunger	1-1/8" Diameter Plunger
Plunger Removal Tool	20477460	20477469
Plug	10079523 (3/8")	10078772 (9/16")
Gland Fitting	10078129 (3/8")	10078608 (9/16")
Seal Removal Tool	10148674	05146618
End Cap Wrench	80079239 (6x 8x)	
Cylinder Wrench	05066139	
Seal Removal Tool Stand	80078330	
Vee Block Cradle	20484961	

9.6 High and Low Pressure Water Piping

Before performing any maintenance on the high pressure components, it is necessary to remove the high and low pressure water piping. The following procedure should be used to remove and install the piping.



Severe injury can result if the machine is not properly locked out. Observe electrical Lockout/Tagout procedures before performing maintenance on the high pressure system components.

Ensure all pressure is relieved or blocked from the hydraulic and high pressure circuits before performing maintenance.

1. Turn the cutting water supply off.
2. Loosen and remove the high pressure gland fitting connected to the discharge high pressure check valve. Move the tubing to clear the work area.
3. Loosen and remove the low pressure piping connected to the inlet water port on the hard seal end cap.
4. When the required maintenance has been completed and the components reassembled, connect the low pressure water piping to the inlet water port on the hard seal end cap.
5. Apply Pure Goop to the threads on the high pressure gland fitting. Before installing the high pressure fitting, ensure proper collar position, 1-1/2 to 2-1/2 threads should be exposed. Install and tighten the fitting to the torque specifications in Table 9-1.
6. Turn the cutting water supply on and check for low pressure leaks.
7. Remove the cutting orifice and start the machine. Operate in low pressure mode to flush the high pressure passages.
8. Install the orifice and operate at high pressure to check for leaks.

9.7 High Pressure Cylinder Assembly

KMT Waterjet recommends removing the high pressure cylinder, sealing head and end cap as an assembly for servicing the plunger, high pressure seals, hydraulic piston and seal cartridge. Removing the jackbolts in the hard seal end cap is not recommended except to service the inlet check valve and cone seat on the sealing head.

High Pressure Cylinder Assembly Removal

Prior to removing electrical power or any high or low pressure piping, start the machine from the Maintenance Screen on the control panel. The machine will start in recirculation mode; the dump valve will open and relieve the high pressure in the system.

Press the right or left arrow to extend the plunger on the end to be serviced. The plunger will extend in the selected direction, allowing full exposure when the unit is disassembled.

1. Turn the machine off and observe the appropriate Lockout/Tagout procedures.



Severe injury can result if the machine is not properly locked out. Observe electrical Lockout/Tagout procedures before proceeding.

Ensure all pressure is relieved or blocked from the hydraulic and high pressure circuits before proceeding.

2. Disconnect the high and low pressure water piping, following the procedure, High and Low Pressure Water Piping.

NOTE

Prior to removal, verify that the alignment marks on the high pressure cylinder and on the hydraulic cylinder head are aligned. If not, check the condition of the retaining ring and the bushing retainer flange after the cylinder assembly is removed.



Due to the weight of the cylinder assembly, adequate support must be provided to prevent damage to the plunger or seals during removal and installation. See Figure 9-7, Specialized Maintenance Tools for tools available to support the high pressure assembly for this procedure.

3. Position the vee block cradle tool under the cylinder assembly. Unthread and remove the assembly from the hydraulic cylinder head and plunger. The assembly can be rotated with the cylinder wrench or by hand.

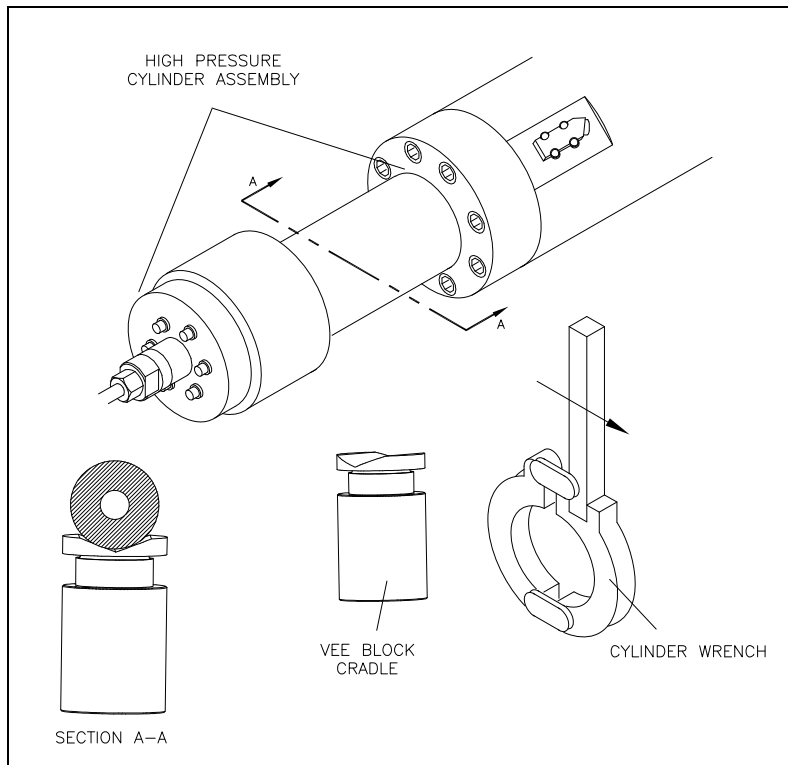
Figure 9-8: High Pressure Cylinder Assembly Removal and Installation**NOTE**

If thread or metal surface galling is detected during removal, galled surfaces and threads must be filed, sanded and lubricated prior to reassembly. See the procedure, High Pressure Cylinder Maintenance.

High Pressure Cylinder Assembly Installation

1. Verify that the high pressure cylinder threads and alignment surfaces are adequately cleaned and lubricated with Pure Goop, and that the threads have been sanded and dressed if galling was encountered during removal.
2. Verify that the high pressure seal assembly, packing follower and cylinder liner are correctly installed. Align the cylinder assembly with the plunger and the hydraulic cylinder head, using the cradle tool to support the weight. Carefully push and lift the assembly into position until the threads are ready to engage.
3. Thread the cylinder assembly into the hydraulic cylinder head.

NOTE

If galling occurs during threading, remove the high pressure cylinder assembly and inspect the mating surfaces and threads. Repair surfaces, thoroughly clean, lubricate and thread the cylinder assembly into the hydraulic cylinder head.

NOTE

An alignment mark is located on the hydraulic cylinder head under the KMT logo. To ensure the high pressure cylinder is properly tightened and fully seated in the hydraulic cylinder head, it is recommended that a corresponding mark be placed on the high pressure cylinder after installation. Periodically inspect the cylinder for movement. If movement is detected, retighten the assembly.

4. Connect the high and low pressure water piping, following the procedure, High and Low Pressure Water Piping.
5. Start the machine in low pressure mode to flush air from the high pressure components and to check for obvious leaks. After 5-10 strokes, switch to high pressure operation and check for leaks.

If leaks are detected, turn the machine off and remedy the problem. When the problem has been remedied, repeat the start up procedure, moving from low to high pressure soon after the intensifier starts pumping water. There is no further need to flush air from the system.

High Pressure Cylinder Maintenance

The plunger seal area in the high pressure cylinder bore should be inspected and cleaned each time the high pressure seal assembly is replaced.

1. Clean the sealing area on the inside diameter of the high pressure cylinder and inspect the bore for rings, scratches, pits, residue or other potential leak paths.
2. Seal material or residue can build up, forming a ring. Running a fingernail across the buildup will cause it to appear as a surface flaw. Grooves or ridges are typically seal debris buildup rather than marks on the inside diameter wall of the cylinder.
3. Polish the inside diameter of the cylinder where the seal will locate with 600-grit wet/dry sandpaper. Hold the sandpaper on the end of your finger and move in a cylindrical wiping motion. Polish in a circumferential motion only. Do not polish or drag the sandpaper along the length of the cylinder.
4. Clean the residue from the inside diameter of the cylinder and re-inspect for surface defects.

9.8 Hard Seal End Caps

KMT Waterjet recommends loosening the jackbolts and removing the hard seal end caps (HSEC) only to service the inlet check valve and the cone seat on the sealing head.

Hard Seal End Cap Removal

Prior to removing electrical power or any high or low pressure piping, start the machine from the Maintenance Screen on the control panel. The machine will start in recirculation mode; the dump valve will open and relieve the high pressure in the system.

Press the RIGHT or LEFT arrow to retract the plunger on the opposite end to be serviced. The plunger will extend in the selected direction, allowing full exposure when the unit is disassembled.

1. Turn the machine off and observe the appropriate Lockout/Tagout procedures.



Severe injury can result if the machine is not properly locked out. Observe electrical Lockout/Tagout procedures before proceeding.

Ensure all pressure is relieved or blocked from the hydraulic and high pressure circuits before proceeding.

2. Disconnect the high and low pressure water piping, following the procedure, High and Low Pressure Water Piping.
3. Loosen the jackbolts in the hard seal end cap.
4. Unscrew and remove the HSEC from the high pressure cylinder.
5. Remove the sealing head. The sealing head may be removed with the HSEC or after the end cap has been removed.
6. On 75 and 100 horsepower units, verify the removal of the white plastic guide bushing used to position the sealing head relative to the high pressure cylinder. The bushing may come out with the sealing head. If not, the bushing must be removed from the cylinder bore prior to reinstalling the sealing head to avoid pushing it farther into the bore.

NOTE

The sealing head on 30, 50 and 60 horsepower units does not utilize a guide bushing.

Figure 9-9: Hard Seal End Cap

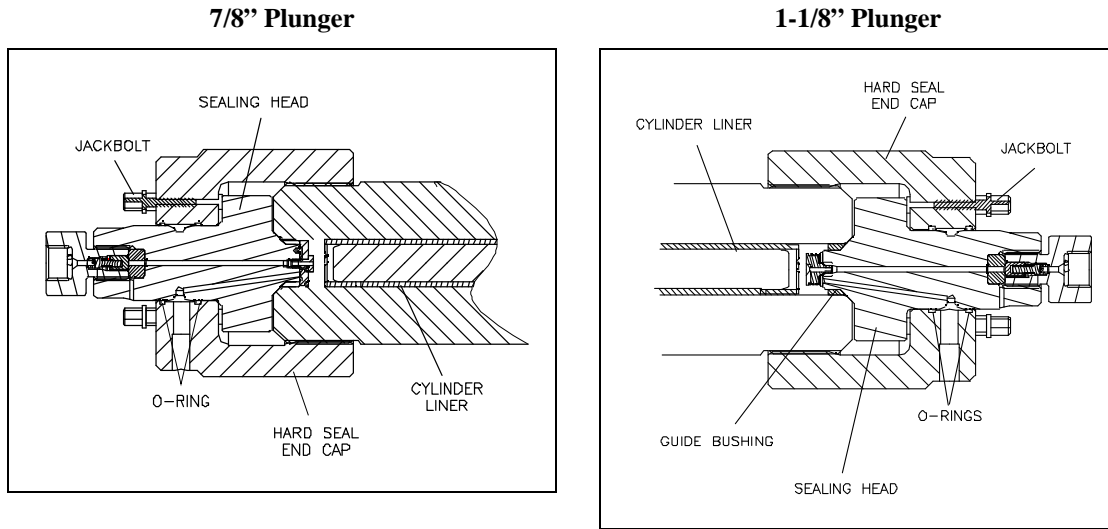

Hard Seal End Cap Installation

7/8" Diameter Plunger

1. Apply FML-2 grease to the two o-rings and verify they are properly installed in the inside diameter grooves of the HSEC. Check the high pressure cylinder bore to verify the presence of the cylinder liner.
2. Apply Pure Goop to the coned sealing surface on the sealing head. Place the sealing head in the end cap and push into position.
3. Apply JL-M grease to the full length of the threads and to the ends of the jackbolts. Apply JL-M grease to the internal threads in the HSEC. Install the jackbolts, ensuring they are slightly less than flush with the inner face of the end cap.

1-1/8" Diameter Plunger

1. Apply FML-2 grease to the two o-rings and verify they are properly installed in the inside diameter grooves of the HSEC. Check the high pressure cylinder bore to verify the presence of the cylinder liner and to ensure the old guide bushing has been removed from the bore.
2. Apply FML-2 grease to the inside and outside diameter of the guide bushing and position the bushing on the inlet end of the sealing head.

Apply Pure Goop to the coned sealing surface on the sealing head. Place the sealing head and the guide bushing in the end of the high pressure cylinder and press the sealing head into the cylinder by hand.
3. Apply JL-M grease to the full length of the threads and to the ends of the jackbolts. Apply JL-M grease to the internal threads in the HSEC. Install the jackbolts, ensuring they are slightly less than flush with the inner face of the end cap.



Make sure the JL-M lube is well mixed and not dried up due to age.

4. Position the end cap on the high pressure cylinder and fully engage the threads on the end cap with the high pressure cylinder. The cone seal on the sealing head should be in contact with the cylinder.
4. Slide the end cap over the sealing head until it makes contact with the sealing head. Fully engage the threads on the end cap with the high pressure cylinder. The cone seal on the sealing head should be in contact with the cylinder.
5. Unscrew the HSEC until the inlet water port is properly oriented to facilitate the low pressure water connection. **Do not** unscrew the HSEC more than one full turn.
6. Hand-tighten the jackbolts until they make contact with the sealing head.
7. Tighten the jackbolts following the tightening sequence and torque specifications in Table 9-1.
8. Connect the high and low pressure water piping and turn the low pressure water supply on.
9. Start the machine in low pressure mode to flush air from the high pressure components and to check for obvious leaks. After 5-10 strokes, switch to high pressure operation and check for leaks.

If leaks are detected, turn the machine off and remedy the problem. When the problem has been remedied, repeat the start up procedure.

9.9 Sealing Head

The sealing head is sealed to the outboard end of the high pressure cylinder by a 45-degree metal-to-metal compression seal. The pre-loading jackbolts in the hard seal end cap hold the sealing head against the end of the cylinder.

The inlet and discharge check valves in the sealing head ensure the low pressure and high pressure water only travels in the appropriate direction.

Figure 9-10: Sealing Head

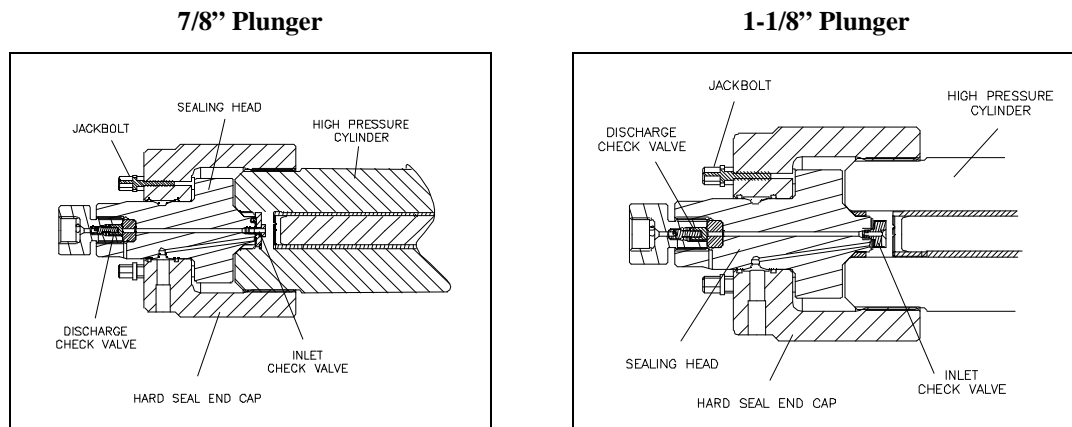

High Pressure Discharge Check Valve

The high pressure discharge check valves should be serviced on a regular, preventive maintenance schedule. Service is recommended every 1,500 hours. The discharge check valve can be serviced with the sealing head either installed or removed from the high pressure cylinder.

1. Turn the machine off and observe the appropriate Lockout/Tagout procedures.



Severe injury can result if the machine is not properly locked out. Observe electrical Lockout/Tagout procedures before proceeding.

Ensure all pressure is relieved or blocked from the hydraulic and high pressure circuits before proceeding.

2. Disconnect the high pressure water piping, following the procedure, High and Low Pressure Water Piping.
3. Use two wrenches to remove the gland nut. The poppet pin, spring and discharge poppet will normally remain in the gland nut when it is removed. Remove the components from the gland nut.
4. Use a magnet to remove the seat from the sealing head.
5. Inspect the poppet pin for wear and replace the pin if worn.
6. Inspect both faces of the seat for damage or cracking. A cracked or damaged seat must be replaced. The seat can be installed with either face toward the discharge poppet. If one face is worn, but the opposite is not, the seat can be reversed, placing the new surface toward the poppet. A slight burr at the hole edge identifies the used side of the seat. If both faces are worn, the seat must be replaced.

NOTE

The seat, spring and discharge poppet should be replaced as a set. If one component requires replacement, replace all components.

Figure 9-11: High Pressure Discharge Check Valve

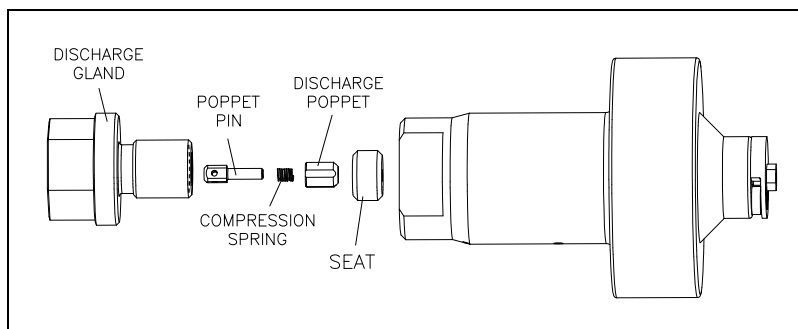

7. Apply a thin film of Pure Goop to the face of the seat opposite the discharge poppet and install the seat into the sealing head. If the existing seat is reused, install the seat with the new surface facing the poppet.
8. Install the poppet pin and the spring, with the larger end of the spring facing the poppet, and then install the poppet into the gland nut.
9. Apply Pure Goop to the sealing face and the threads on the gland nut and thread the gland nut into the sealing head. Hand-tighten until there is a 0.20 inch (5 mm) gap between the gland nut and the sealing head. No threads should show. If the gap exceeds 0.20 inch (5 mm), the poppet or seat has slipped out of position. The parts must be removed, inspected and re-assembled.
10. Use a crowfoot/torque wrench combination and tighten the gland nut to the torque specifications in Table 9-1.

Low Pressure Inlet Check Valve

The inlet check valve components differ, depending on the plunger diameter. See Figure 9-12, Low Pressure Inlet Check Valve.

Figure 9-12: Low Pressure Inlet Check Valve

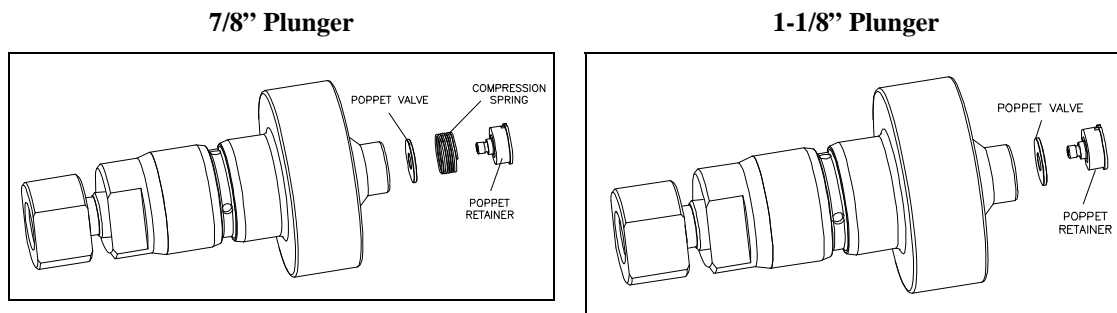

The inlet check valves should be serviced on a regular, preventive maintenance schedule. Service is recommended every 1,000 hours for units with 7/8" diameter plungers and every 1,500 hours for units with 1-1/8" diameter plungers. The hard seal end cap must be removed to service the inlet check valve. Follow the procedure, Hard Seal End Cap Removal. When the end cap has been removed, proceed with Step 1 below.

7/8" Diameter Plunger

1. Use a 5/16-inch wrench or socket to remove the poppet retainer screw. Remove the retainer and the inlet poppet from the sealing head.
2. Inspect the sealing head for scratches or wear on the cone ring contact surface, and on the inlet poppet valve contact surface. If defects are detected, the surfaces must be refinished. See the procedure, Sealing Head Maintenance.

1-1/8" Diameter Plunger

1. Use a 1/2-inch flat blade screwdriver to remove the poppet retainer and the inlet poppet from the sealing head.
2. Inspect the sealing head for scratches or wear on the cone ring contact surface, and on the inlet poppet contact surface. If defects are detected, the surfaces must be refinished. See the procedure, Sealing Head Maintenance.

7/8" Diameter Plunger

3. Place the inlet poppet in the hole in the poppet retainer as shown below. Position the inlet poppet and retainer on the sealing head, placing the dowel pin in the appropriate hole in the sealing head.

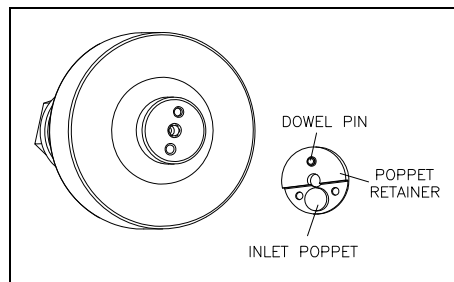
Inlet Poppet Installation

There are two holes in the sealing head. The dowel pin on the poppet retainer is positioned in one and the inlet poppet is positioned over the other. Ensure that the inlet poppet is positioned over the **through** hole in the sealing head.

1-1/8" Diameter Plunger

3. Inspect both faces on the inlet poppet. The poppet can be installed with either face toward the sealing head. If one face is worn, but the opposite is not, the poppet can be reversed, placing the best surface toward the sealing head. If both faces are worn, the poppet must be replaced.
 4. Spray Loctite 7649 on the threads of the poppet retainer and allow to dry. Apply one drop of Loctite 242 on the threads only. **Do not** get any Loctite on the poppet or any other surfaces on the inlet check valve.
 5. Use the flat blade screwdriver to tighten the poppet retainer. Tighten the poppet retainer to the torque specifications in Table 9-1.
 6. Inspect the assembled unit to ensure the poppet moves freely and the poppet retainer is seated against the sealing head.
4. Spray Loctite 7649 on the threads of the retainer screw and allow to dry. Apply one drop of Loctite 242 on the threads only. **Do not** get any Loctite on the poppet or any other surfaces on the inlet check valve.
 5. Use the wrench or socket to tighten the poppet retainer screw. Tighten the poppet retainer screw to the torque specifications in Table 9-1.
 6. Inspect the assembled unit to ensure the poppet moves freely and the poppet retainer screw is seated.

Sealing Head Maintenance

The sealing head should be inspected for scratches, excessive sealing damage or erosion marking on the cone ring contact surface, and on the inlet poppet valve contact surface. If defects are detected, the surfaces must be refinished. The sealing head can be returned to KMT Waterjet for refinishing.

1. Clean the 45-degree surface on the cone ring with 600-grit wet/dry sandpaper, using a radial motion. It will not be possible to fully remove the main sealing marks.
2. Inspect the inlet poppet valve sealing surface for pits, scratches or jetting erosion. If necessary, refinish the surface.

Place a piece of 1/4-1/2" thick plate glass, not window glass, on a sturdy table to provide an absolutely flat surface. Place a piece of 400-grit wet/dry sandpaper on the glass. Use even, deliberate strokes, rotating the sealing head approximately 10-15 degrees after each stroke. Polish the sealing head until it is flat and smooth. Be careful not to cause additional damage by tilting or tipping the part while polishing.

3. When the sealing head is flat and smooth, perform a final polish with 600-grit wet/dry sandpaper.

9.10 High Pressure Seal Assembly

The following procedure should be used to replace the high pressure seal assembly. Seal components differ slightly, depending on the plunger diameter. See Figure 9-13, High Pressure Seal Assembly.

Figure 9-13: High Pressure Seal Assembly

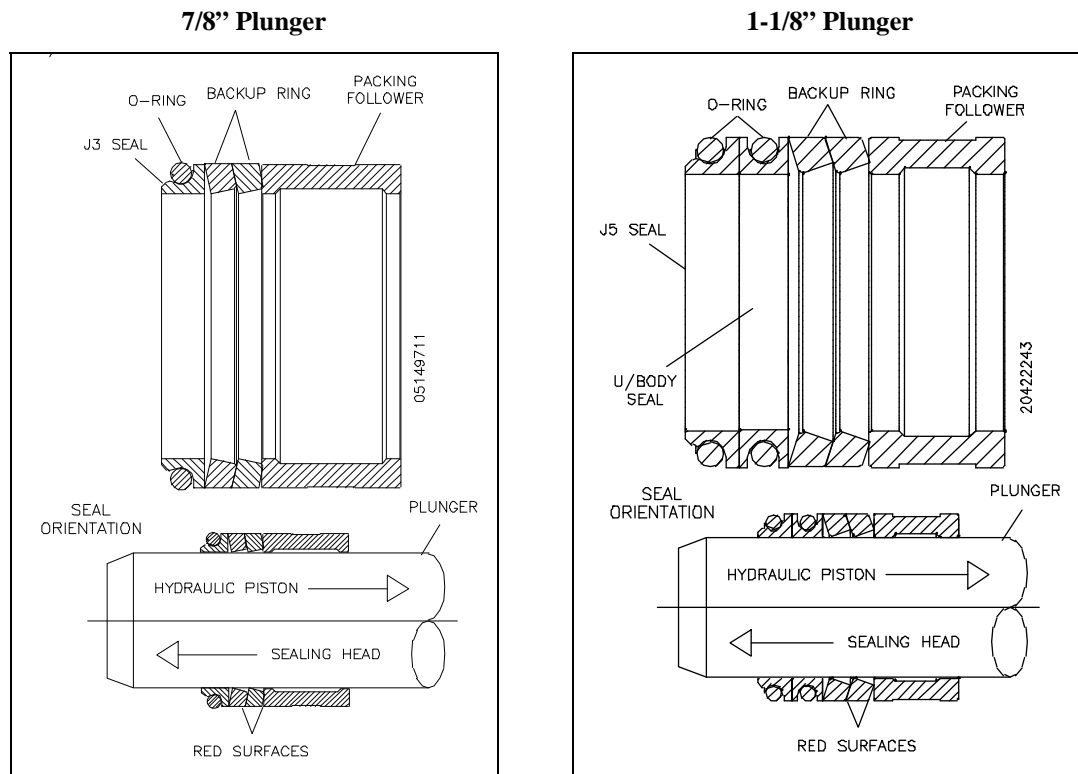

Prior to removing electrical power or any high or low pressure piping, start the machine from the Maintenance Screen on the control panel. The machine will start in recirculation mode; the dump valve will open and relieve the high pressure in the system.

Press the RIGHT or LEFT arrow to extend the plunger on the end to be serviced. The plunger will extend in the selected direction, allowing full exposure when the unit is disassembled.

1. Turn the machine off and observe the appropriate Lockout/Tagout procedures.



Severe injury can result if the machine is not properly locked out. Observe electrical Lockout/Tagout procedures before proceeding.

Ensure all pressure is relieved or blocked from the hydraulic and high pressure circuits before proceeding.

2. Disconnect the high and low pressure water piping, following the procedure, High and Low Pressure Water Piping.
3. Remove the high pressure cylinder assembly, following the procedure, High Pressure Cylinder Assembly Removal.

Figure 9-14: High Pressure Seal Removal

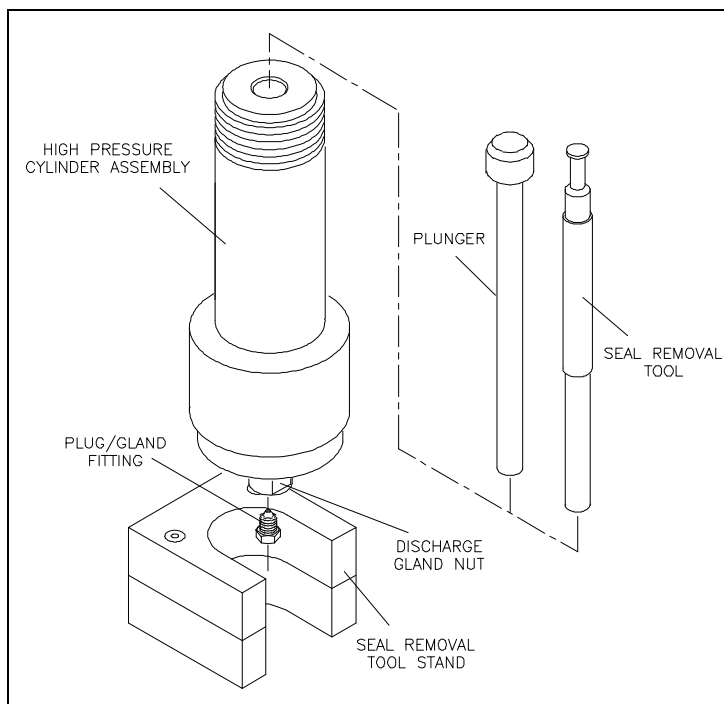

4. Apply Pure Goop to the threads on the high pressure plug and gland fitting. Thread the plug and gland fitting into the discharge gland nut on the sealing head and hand tighten.

5. Position the cylinder assembly upright in the seal removal tool stand. If a tool stand is not available, position the cylinder on a platform of wooden blocks with the jackbolts resting on the platform.



Do not stand the cylinder assembly on the top pan of the machine. The assembly is heavy and must be properly supported to prevent it from falling.

6. Fill the cylinder with water and slide the seal removal tool or a used plunger into the bronze packing follower to ensure a good seal for the removal of the seal assembly.
7. Place a shop towel around the plunger or seal removal tool to avoid splash back. Use a dead blow hammer to drive the removal tool or plunger into the cylinder until the seal components move up and out of the cylinder.
8. Remove the cylinder liner from the bore and inspect for possible heat or wear damage, or for debris. If cracks or brittleness are detected on the tabs on the ends of the liner, the liner must be replaced.
9. Feel approximately one inch into the cylinder bore for obvious ridges or grooves. If seal debris is present, follow the procedure, High Pressure Cylinder Maintenance.
10. Inspect the plunger surface for flaws. Rotate the plunger 360 degrees by hand while viewing light reflection on the surface to detect any dullness, streaks, pits or other defects. Run a fingernail perpendicular to the direction of the suspected flaws to determine the severity of defects. Depending on the seal life achieved with the removed seal assembly, make a judgment regarding plunger and/or cylinder replacement. If seal debris is present on the plunger, polish with 600-grit wet/dry sandpaper, using a radial motion.
11. Lightly coat the new seal components with FML-2 grease and install the new components on the plunger. Ensure the proper orientation of the backup rings as illustrated in Figure 9-13, High Pressure Seal Assembly.
12. Slide the cylinder liner over the plunger.
13. Install the high pressure cylinder assembly into the hydraulic cylinder head, following the procedure, High Pressure Cylinder Assembly Installation.
14. Reconnect the high and low pressure water piping and turn the low pressure water supply on.

9.11 Hydraulic Cartridge Seal and Plunger Removal

The following procedure is used to remove the hydraulic cartridge seal and the plunger.

Prior to removing electrical power or any high or low pressure piping, start the machine from the Maintenance Screen on the control panel. The machine will start in recirculation mode, the dump valve will open and relieve the high pressure in the system.

Press the RIGHT or LEFT arrow to extend the plunger on the end to be serviced. The plunger will extend in the selected direction, allowing full exposure when the unit is disassembled.

1. Turn the machine off and observe the appropriate Lockout/Tagout procedures.



Severe injury can result if the machine is not properly locked out. Observe electrical Lockout/Tagout procedures before proceeding.

Ensure all pressure is relieved or blocked from the hydraulic and high pressure circuits before proceeding.

2. Disconnect the high and low pressure water piping, following the procedure, High and Low Pressure Water Piping.
3. Remove the proximity switch on the end of the hydraulic cylinder to be serviced. This will allow the hydraulic oil to drain back to the reservoir, minimizing oil spillage. It will take approximately five minutes for the oil to drain.
4. Remove the high pressure cylinder assembly, following the procedure, High Pressure Cylinder Assembly Removal.
5. Use a flat screwdriver to remove the retaining ring from the hydraulic cylinder head.
6. Remove the bushing retainer flange and clean the surfaces, weep holes and grooves. Check the retainer flange for cracks.
7. Replace the proximity switch by positioning the o-ring spacer and the switch. Apply JL-M grease to the threads on the socket head screws and tighten, following the torque specifications in Table 9-1.



It is recommended that the proximity switch be reinstalled as soon as practical. Removal of the switch presents the potential of an oil spray hazard.

Ensure that the proximity switch is properly installed and secured prior to starting the machine. Failure to tighten the two hold down screws on each switch will result in the spray of hydraulic oil.

8. Remove the collet from the plunger removal tool and thread the large end of the tool onto the hydraulic cartridge seal and pull the cartridge out, over the plunger.

Figure 9-15: Hydraulic Cartridge Seal Removal

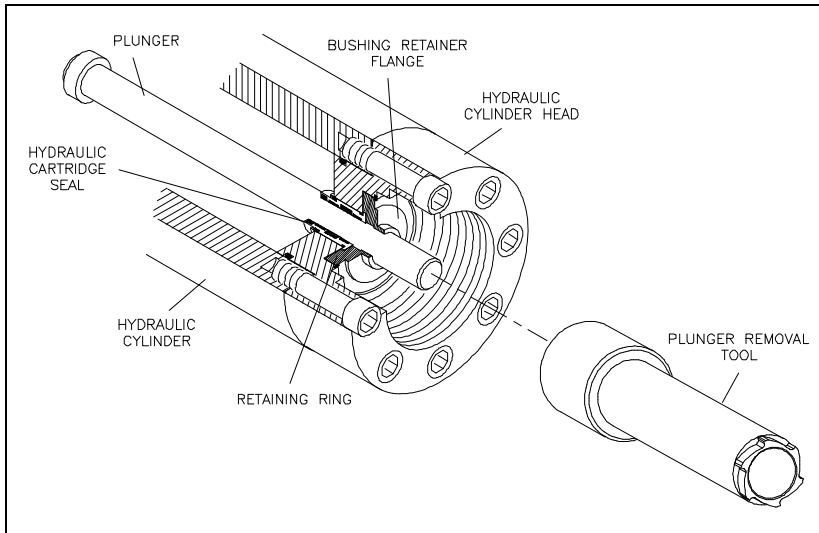

9. With the cartridge removed, the plunger can now be removed with the hydraulic cylinder head in place. The plunger is held in position by six retainer pins. The pins close around the plunger button to retain the plunger, and retract to release the plunger.

Clean the plunger and the ID of the collet with alcohol or a similar solvent. Partially thread the collet into the plunger removal tool and slide the removal tool over the plunger with the lobed end toward the plunger button. Note the orientation of the retainer pins on the plunger button. Align the lobes on the tool with the retainer pins as shown below. Tighten the collet and rotate the tool slightly, causing the pins to retract and release the plunger. Remove the plunger from the hydraulic piston.

Figure 9-16: Plunger Retainer Pins

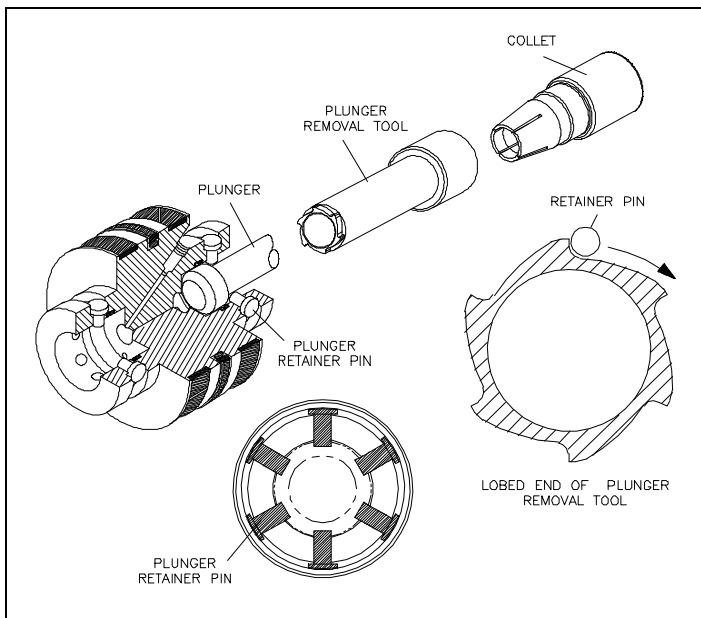

Plunger Maintenance

Plunger surfaces can become streaked with longitudinal scratches or flaws, and discolored or dull in appearance. If any of these conditions become severe, the high pressure seal assembly and possibly the hydraulic cartridge seal will leak.

Accumulation of debris on the surface of the plunger can be removed by polishing in a radial direction with 600-grit sandpaper. However, plunger surface flaws usually cannot be repaired on site. The plunger can be returned to KMT Waterjet for reconditioning.

Figure 9-17: Plunger

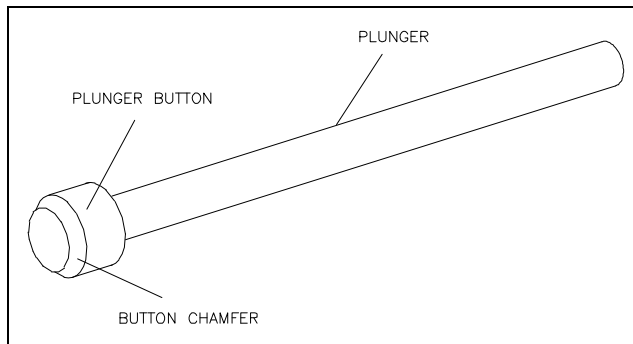

Plunger Installation

To install the plunger, slide the plunger removal tool over the plunger with the lobed end toward the plunger button to help center the plunger in the hydraulic cylinder head. Position the plunger in the button socket of the piston and force the plunger into place by hand. Use a flashlight to verify that all six pins are equally extended to grip the plunger button.

Hydraulic Cartridge Seal Installation

Seals in the hydraulic cartridge can be removed and replaced, or the complete cartridge can be replaced. Seal components differ slightly, depending on the plunger diameter. See Figure 9-18, Hydraulic Cartridge Seal.

Use caution during the removal and installation of the seal components to avoid scratching the surface of the cartridge. The seal removal tool, a plastic or wooden dowel, or similar object can be used for seal removal. **Do not** use screwdrivers, wires or other metal objects that could damage the cartridge. To avoid damaging the new seals, the seal installation tool can be used for installation.

Figure 9-18: Hydraulic Cartridge Seal

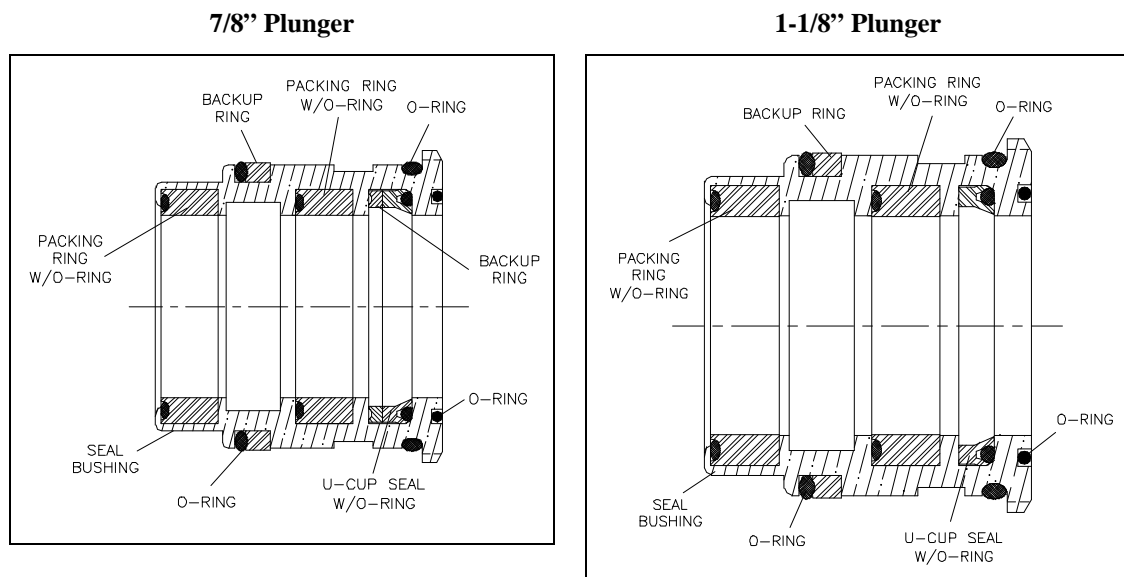

1. Carefully remove the worn seals and o-rings from the cartridge by pushing them with a plastic or wooden dowel, or similar object. Remove the seals closest to the open ends first, and work toward the center.
2. Inspect the seals for unusual wear, deformation or cuts. Note any unusual buildup of solid material or debris creating possible leak paths.
3. Inspect the surface of the cartridge body for scratches, deformation, signs of metal-to-metal contact or other unusual wear. Carefully examine the surface of the grooves on the inside diameter. Note any scratches in the axial direction that could create a leak path.
4. Apply FML-2 grease to the inside and outside diameter of the cartridge body, and to the individual seal components.
5. Install the seals, starting in the center and working toward the ends. See Figure 9-18 for the proper orientation of the u-cup seals. If available, use the seal installation tool to install the u-cup seals. See Figure 9-24, Pneumatic Valve Seal Tools.
6. Verify that the u-cup o-rings are properly positioned after installation.
7. When the seal components are properly installed, apply FML-2 grease to the exposed surfaces of the seals and slide the hydraulic cartridge seal over the plunger, into the cavity of the hydraulic cylinder head.

8. Thoroughly clean the bushing retainer flange, including the cross-drilled weep holes. Install the retainer flange over the plunger.
9. Install the retaining ring, ensuring the retaining ring fully seats inside the groove in the hydraulic cylinder head.

The o-rings on the hydraulic cartridge will take up clearance. Tap lightly on the bushing retainer flange with the plunger removal tool to compress the o-rings enough to start the retaining ring in the groove. Use a flat blade screwdriver to push on the outer edge of the retainer flange while working one end of the retaining ring into the groove. The retainer flange should tilt or tip enough to allow the retaining ring to move into the groove. Continue working the ring into the groove while tilting the retainer flange until the ring is fully seated.

10. Install the high pressure cylinder assembly into the hydraulic cylinder head, following the procedure, High Pressure Cylinder Assembly Installation.
11. Connect the high and low pressure water piping and turn the low pressure water supply on.

9.12 Hydraulic Piston

Two bearing rings provide wear contact between the piston and the inside diameter of the hydraulic cylinder. On each end of the piston, six retainer pins hold the plunger in position. The plunger retainer pins are held in place by a flat snap ring. Two internal check valves vent unwanted hydraulic pressure from one side of the piston to the other, preventing pressure from building behind the plunger button.

Figure 9-19: Hydraulic Piston Components

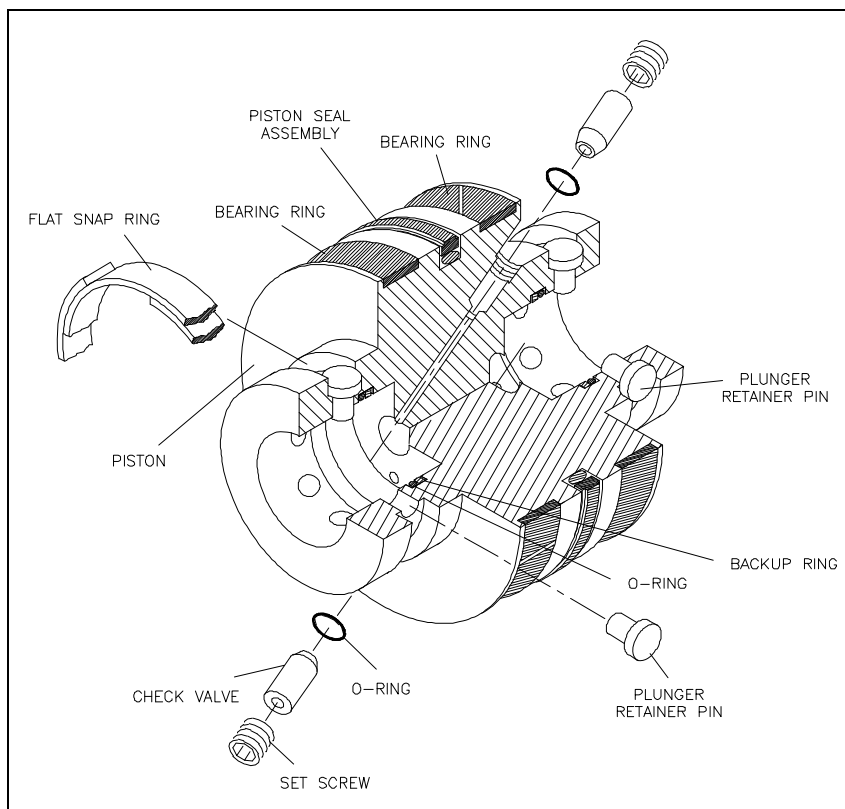

Hydraulic Piston Removal

The following procedure is used to remove the hydraulic piston.

1. Turn the machine off and observe the appropriate Lockout/Tagout procedures.



Severe injury can result if the machine is not properly locked out. Observe electrical Lockout/Tagout procedures before proceeding.

Ensure all pressure is relieved or blocked from the hydraulic and high pressure circuits before proceeding.

2. Disconnect the high and low pressure water piping from both ends of the intensifier, following the procedure, High and Low Pressure Water Piping.
3. Remove the high pressure cylinder assembly on each end of the intensifier, following the procedure, High Pressure Cylinder Assembly Removal.

Figure 9-20: Hydraulic Piston Removal

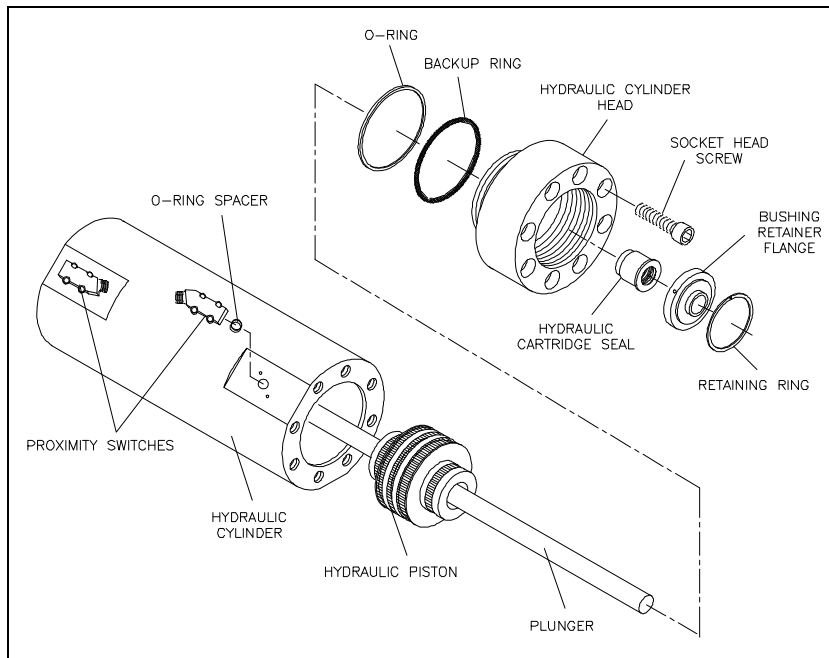

4. Remove both of the proximity switches to prevent interference and to allow the hydraulic oil to drain back to the reservoir, minimizing oil spillage. It will take approximately five minutes for the oil to drain.
5. Remove the retaining ring, bushing retainer flange and the hydraulic cartridge seal from both hydraulic cylinder heads. It is not necessary to remove the plunger.
6. Loosen and remove the socket head screws in one of the hydraulic cylinder heads.

7. Remove the hydraulic cylinder head with the o-ring and backup ring. The mounting flat for the proximity switch provides a small lip for loosening the cylinder head.
8. Grasp the plunger firmly and pull the piston out of the hydraulic cylinder.

Bearing Rings and Seal Assembly

1. Remove the plungers.
2. Use a smooth, dull-edged blade made from brass or similar soft metal material to remove the two bearing rings and the seal assembly.

NOTE

Do not scratch the surfaces of the piston seal groove. Scratches on the sides or bottom of the groove can result in hydraulic leaks.

3. Inspect the bottom of the seal grooves for marks, scratches and residue buildup. Clean and/or repair the groove surfaces as required.
4. Apply FML-2 grease to the new bearing rings and install the rings.
5. The piston seal assembly consists of an inner and an outer seal ring. Apply FML-2 grease to both rings. Use the smooth, dull-edged blade to install the inner ring, ensuring the ring is not twisted after installation. Slide the outer seal ring over the metal edges and ease it into position over the inner ring.

Figure 9-21: Hydraulic Piston

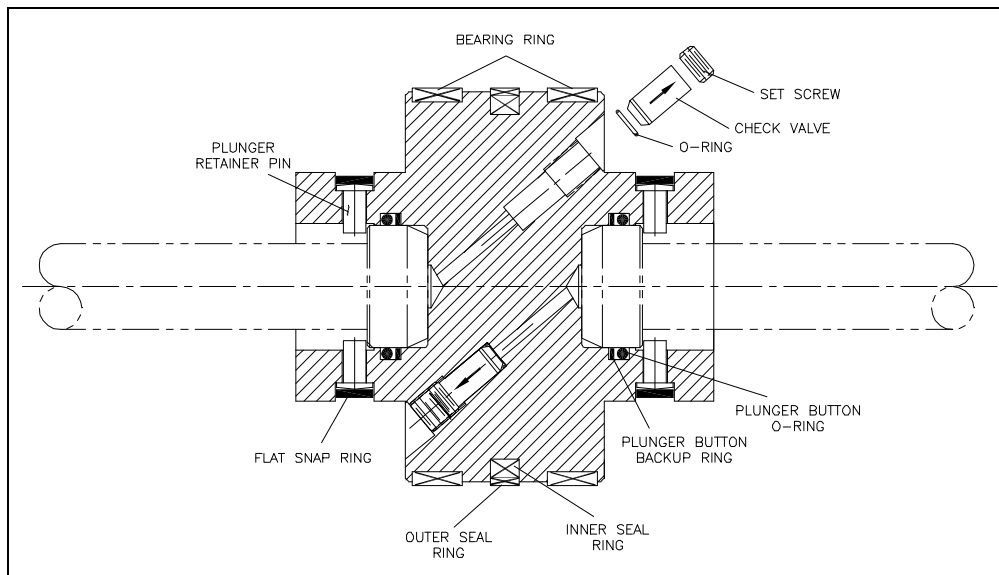

Plunger Button Sockets, Seals and Retainer Pins

1. Remove the flat snap rings and plunger retainer pins on both ends of the piston.
2. Inspect the snap rings and the pins for unusual wear or deformation. Clean and inspect the pin holes for unusual wear, deformation or hole enlargement.

3. Remove the plunger button o-ring and backup ring from each plunger socket. Take care not to scratch or damage the seal groove surfaces.
4. Clean and inspect the seal grooves for residue buildup or surface marks that could cause seal leaks.
5. Inspect the plunger button sockets for unusual wear.

NOTE

Due to the high contact force between the piston and the plunger, the plunger may make an impression in the bottom of the socket. This compression mark or indentation is normal.

6. Apply FML-2 grease to new plunger button backup rings and o-rings. Install the rings in the internal groove in the plunger socket. If the backup ring is not installed the plunger can be forced out of the plunger socket.
7. Install the retainer pins, verifying that each pin moves freely without excess side play in the pin holes.
8. Install the flat snap ring over the pins.
9. Install the plungers and check the snap-in feature of the plunger attachment. Use the plunger removal tool to ensure the pins retract to release the plunger, and close to retain the plunger in a uniform manner.

Internal Check Valves

It is not necessary to service the internal check valves unless a problem is suspected. If the check valves or the internal passages in the piston require service, plunger button, seal and pin servicing is also recommended. See Figure 9-21, Hydraulic Piston.

1. Loosen the set screw and remove the check valves and o-rings. Clean the internal passages.
2. Apply FML-2 grease to a new o-ring and install the new o-ring in the check valve passage. Use a blunt, pencil-like instrument to position it in the bottom of the passage.
3. Clean and install a new check valve with the chamfered end toward the o-ring.
4. Springly apply Loctite, threadlocker adhesive to the set screw. Thread the screw over the check valve cartridge and tighten.

NOTE

Excess threadlocker adhesive can clog the check valve or block the internal passage. To avoid excess adhesive, position the set screw on an Allen wrench and apply the adhesive. Hold the screw horizontal on a paper towel and rotate the screw to remove excess adhesive.

Hydraulic Piston Installation

1. Ensure that the hydraulic cylinder bore is free of grit or contamination.
2. Lubricate the bearing rings and seal assembly, and lightly lubricate 2-3 inches of the cylinder bore with FML-2 grease.

Figure 9-22: Hydraulic Piston Installation

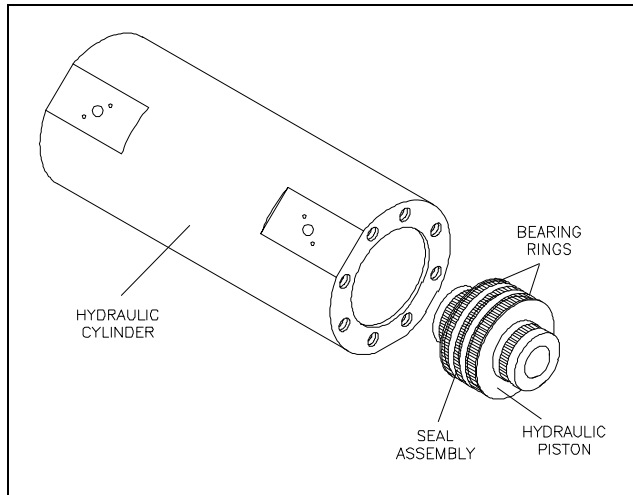

3. Install the piston into the hydraulic cylinder bore. If necessary, use a plastic head hammer to drive the piston into position between the holes for the proximity switches.
4. Install the plungers and check the snap-in feature of the plunger attachment. Use the plunger removal tool to ensure the pins retract to release the plunger, and close to retain the plunger in a uniform manner.
5. Verify that the o-ring and backup ring are properly positioned in the groove on both hydraulic cylinder heads, and that they are sufficiently lubricated with FML-2 grease.
6. Position the cylinder heads in the ends of the hydraulic cylinder. Apply JL-M grease to the threads on the socket head screws. Install the screws in each hydraulic cylinder head and tighten, following the torque specifications in Table 9-1.
7. Replace the hydraulic cartridge seal, bushing retainer flange and retaining ring in both hydraulic cylinder heads.
8. Replace the proximity switches by positioning the o-ring spacers and the switches. Apply JL-M grease to the threads on the socket head screws and tighten, following the torque specifications in Table 9-1.



Ensure that the proximity switches are properly installed and secured prior to starting the motor. Failure to tighten the two hold down screws on each switch will result in the spray of hydraulic oil.



9. Install the high pressure cylinder assemblies into the hydraulic cylinder heads, following the procedure, High Pressure Cylinder Assembly Installation.
10. Connect the high and low pressure water piping. And turn the low pressure water supply on.

9.13 Hydraulic Piston Maintenance

The inside diameter surface of the hydraulic cylinder should be inspected for wear grooves and surface finish whenever the hydraulic cylinder heads are removed. Excessive grooving is indicative of piston seal wear.

9.14 High Pressure Attenuator

The high pressure attenuator is not serviceable at the customer level. KMT Waterjet Systems tests the seals in the attenuator at pressures exceeding normal operating pressure, making disassembly difficult. If the attenuator develops a high pressure water leak, it should be replaced.

9.15 High Pressure Dump Valve

The high pressure dump valve assembly includes a normally open high pressure water valve and a solenoid operated air valve. The SL-V 30, 50 and 60 are equipped with a round, three port dump valve assembly. A square, two port dump valve assembly is installed on SL-V 75, 100 and 100D models. The following procedures are recommended for servicing each high pressure dump valve. Failure to follow these procedures will cause damage to the stem, valve seat, or both.



The high pressure dump valve is a safety device designed to instantly release high pressure from the system. **Proper maintenance is imperative** to prevent potential personal injury.

Figure 9-23, Pneumatic Valve Seal Tools, illustrates the special tools recommended for this procedure.

Figure 9-23: Pneumatic Valve Seal Tools

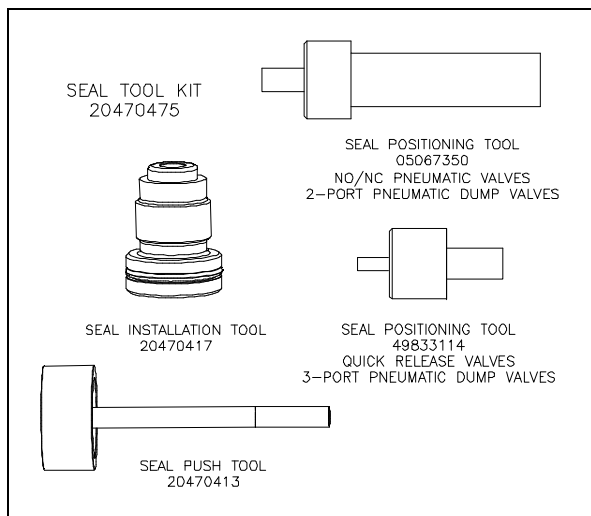

3-Port Pneumatic Control Dump Valve (SL-V 30, 50 and 60)

For reliable operation the valve seat, seal assembly, brass backup ring and stem shall always be replaced at the same time. The SST backup ring can be reused.

Before proceeding, disconnect and lockout the main power supply and the electrical enclosure; and ensure that all high pressure water and hydraulic pressure has been bled from the system.



Severe injury can result if the machine is not properly locked out. Observe electrical Lock Out/Tag Out procedures before proceeding.

Ensure all pressure is relieved or blocked from the hydraulic and high pressure circuits before proceeding.

1. Turn the air supply off.
2. Remove the air supply hose, and the electrical connection to the solenoid valve.

Figure 9-24: 3-Port High Pressure Dump Valve

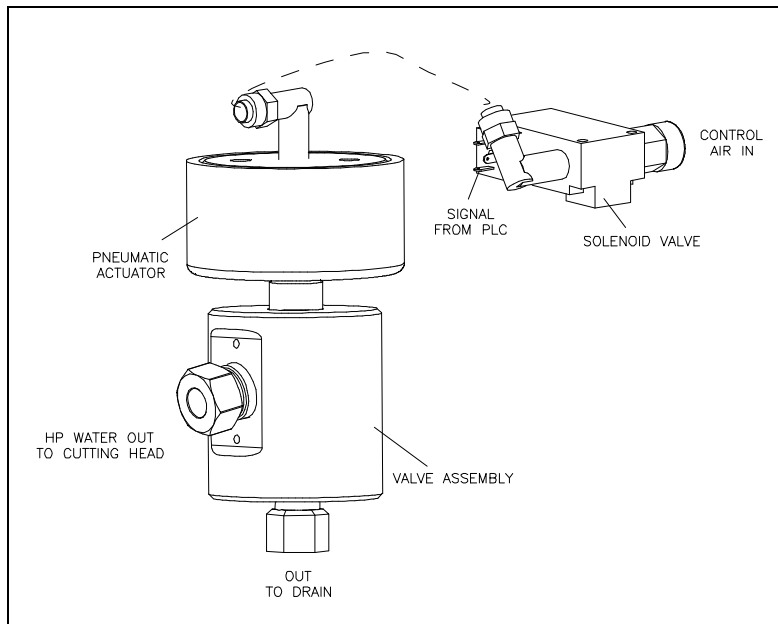

3. Loosen and remove the high pressure gland connections and the drain connection.
4. Remove the valve and actuator assembly from the machine.

Figure 9-25: 3-Port Dump Valve Components

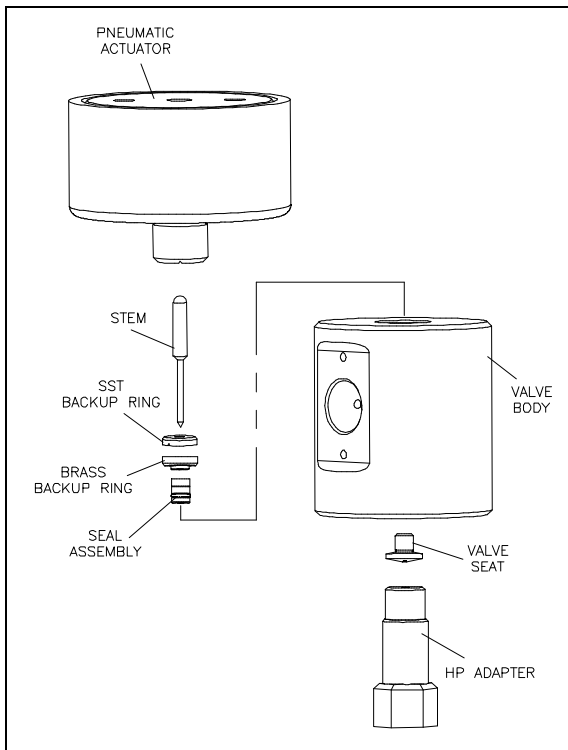

5. Loosen the cylinder head on the actuator. Unscrew and remove the actuator from the valve body.
6. Unscrew the high pressure adapter and remove the adapter and valve seat.
7. Remove the stem, SST backup ring and brass backup ring from the valve body.
8. Remove the seal assembly by pushing it with the seal push tool (P/N 20470413). The assembly must be pushed out through the actuator port in the top of the valve body.
9. Discard the stem, brass backup ring, seal assembly and valve seat.
10. Clean and inspect the valve body, being careful not to damage or scratch the bore.

Figure 9-26: Valve Seal Installation

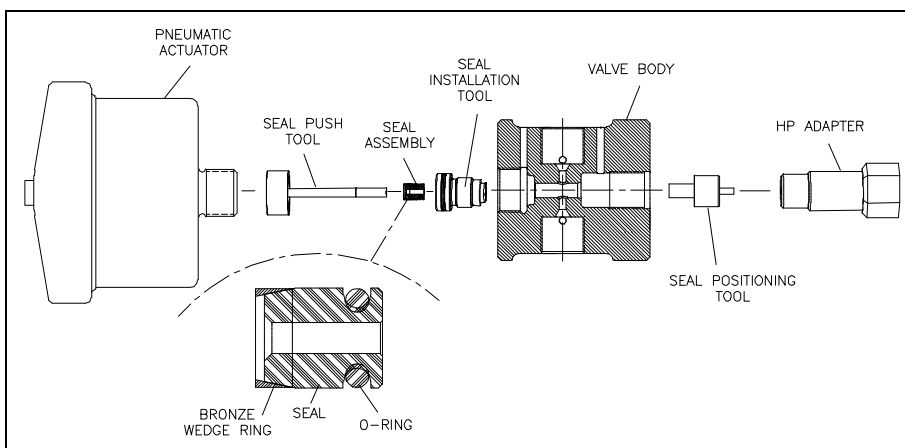

11. Place the seal positioning tool into the opposite end of the valve body as shown in Figure 9-26, Valve Seal Installation. Thread the high pressure adapter into the valve body until light contact is made with the positioning tool. Tighten finger-tight only.
12. Apply Pure Goop anti-seize compound to the threads on the seal installation tool. Screw the seal installation tool into the threads of the valve body. Tighten finger-tight only. See Figure 9-26, Valve Seal Installation.
13. Lubricate the new seal and o-ring with FML-2 food grade grease. Insert the seal, o-ring and bronze wedge ring into the seal installation tool, inserting the o-ring end of the seal first so the tapered end of the seal (wedge ring end) faces the actuator. The tapered end of the seal must face the actuator. See Figure 9-26, Valve Seal Installation.
14. Use the seal push tool to push the seal assembly into the bore of the valve body until the seal makes light contact with the seal positioning tool.
15. Remove the push tool and the installation tool from the valve body.
16. Install the existing SST backup ring and a new brass backup ring on a new stem. The vee groove on the SST backup ring must face toward the brass backup ring. The small OD of the brass backup ring must face toward the seal assembly. See Figure 9-25, 3-Port Dump Valve Components.
17. Apply FML-2 grease to the tip of the stem and insert the stem with the backup rings into the top of the valve body so the stem enters the ID of the seal assembly. **Insert the stem until the chamfer on the stem is seated against the SST backup ring.** See Figure 9-27, Valve Stem Placement.



Do not push the o-ring on the seal assembly past the inlet port on the valve body. This will damage the seal o-ring.

Figure 9-27: Valve Stem Placement

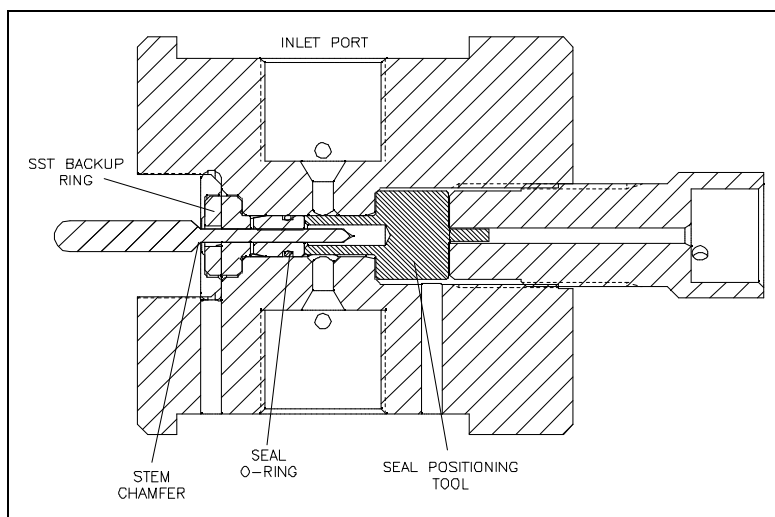

18. Remove the high pressure adapter and the seal positioning tool.
19. Apply Pure Goop anti-seize compound to the threads of the actuator and carefully thread it into the valve body, guiding the stem head into the hole in the actuator. Turn the actuator clockwise until resistance is felt. Reverse the actuator 1/4-turn, and give it a quick spin clockwise to seat it. Hand-tighten only, 5 ft-lbs (7 Nm).
20. Apply Pure Goop anti-seize compound to all surfaces, except the ID, of a new valve seat. Install the seat into the valve body, inserting the small OD first.
21. Apply anti-seize compound to the threads on the high pressure adapter. Install the adapter and torque to 25 ft-lbs (34 Nm).
22. Replace the 1/4-inch drain gland nut and collar and torque to 25 ft-lbs (34 Nm).
23. Apply anti-seize compound to the threads on the 3/8-inch high pressure gland fittings. Install the collar and the gland fittings and torque to 50 ft-lbs (68 Nm).
24. Install the air supply hose and the electrical connection to the solenoid valve. Turn the air pressure to the actuator on and test the valve for leaks and proper operation.

2-Port Pneumatic Control Dump Valve (SL-V 75, 100 and 100D)

For reliable operation the valve seat, seal assembly, brass backup ring and stem shall always be replaced at the same time. The SST backup ring can be reused.

Before proceeding, disconnect and lockout the main power supply and the electrical enclosure; and ensure that all high pressure water and hydraulic pressure has been bled from the system.



Severe injury can result if the machine is not properly locked out. Observe electrical Lock Out/Tag Out procedures before proceeding.

Ensure all pressure is relieved or blocked from the hydraulic and high pressure circuits before proceeding.

1. Turn the air supply off.
2. Remove the air supply hose, and the electrical connection to the solenoid valve.

Figure 9-28: 2-Port High Pressure Dump Valve

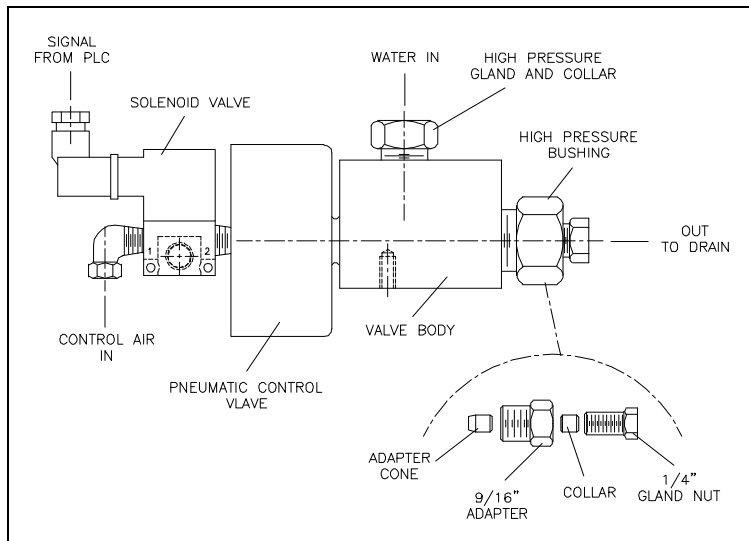

3. Loosen and remove the high pressure gland connection and the drain connection.
4. Remove the valve and actuator assembly from the machine.

Figure 9-29: 2-Port Dump Valve Components

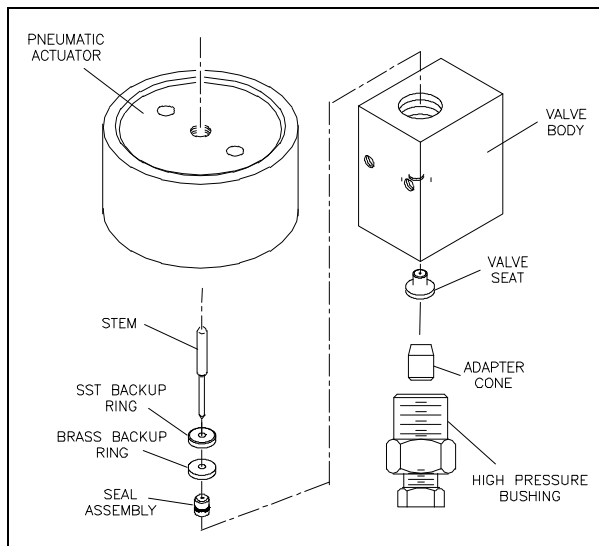

5. Loosen the cylinder head on the actuator. Unscrew and remove the actuator from the valve body.
6. Unscrew the high pressure bushing and remove the bushing, adapter cone and valve seat.
7. Remove the stem, SST backup ring and brass backup ring from the valve body.
8. Remove the seal assembly by pushing it with the seal push tool (P/N 20470413). The assembly must be pushed out through the actuator port in the top of the valve body.
9. Discard the stem, brass backup ring, seal assembly and valve seat.
10. Clean and inspect the valve body, being careful not to damage or scratch the bore.

Figure 9-30: Valve Seal Installation

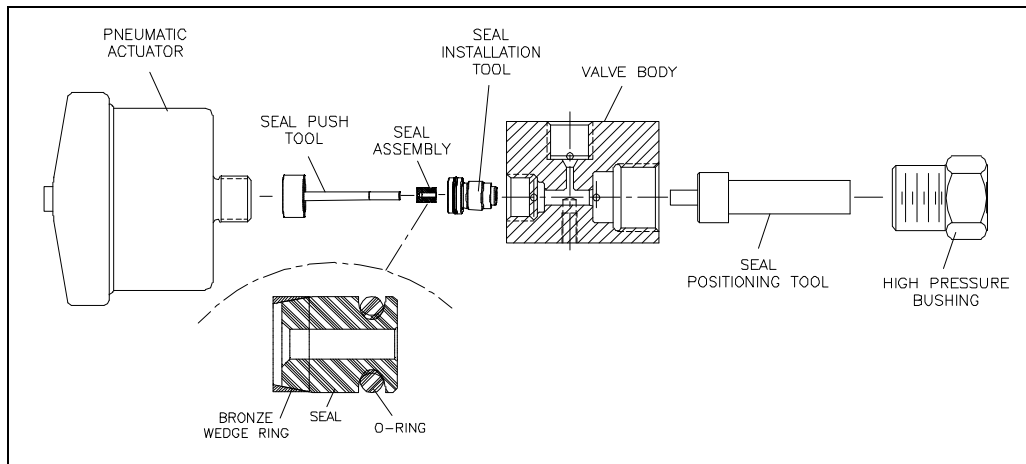

11. Place the seal positioning tool into the end of the valve body as shown above. Thread the high pressure bushing into the valve body until light contact is made with the positioning tool. Tighten finger-tight only. See Figure 9-30, Valve Seal Installation.
12. Apply Pure Goop anti-seize compound to the threads on the seal installation tool. Screw the seal installation tool into the threads of the valve body. Tighten finger-tight only. See Figure 9-30, Valve Seal Installation.
13. Lubricate the seal and the o-ring with FML-2 food grade grease. Insert the seal and o-ring, with the bronze wedge ring, into the seal installation tool. Insert the o-ring end of the seal first so the tapered end of the seal (wedge ring end) faces the actuator. The tapered end of the seal must face the actuator. See Figure 9-30, Valve Seal Installation.
14. Use the seal push tool to push the seal assembly into the bore of the valve body until the seal makes light contact with the positioning tool.
15. Remove the push tool and the installation tool from the valve body.
16. Install the existing SST backup ring and a new brass backup ring on a new stem. The vee groove on the SST backup ring must face toward the brass backup ring. The small OD of the brass backup ring must face toward the seal assembly.
17. Apply FML-2 grease to the tip of the stem and insert the stem with the backup rings into the top of the valve body so the stem enters the ID of the seal assembly. Insert the stem until the chamfer on the stem is seated against the SST backup ring. See Figure 9-31, Valve Stem Placement.

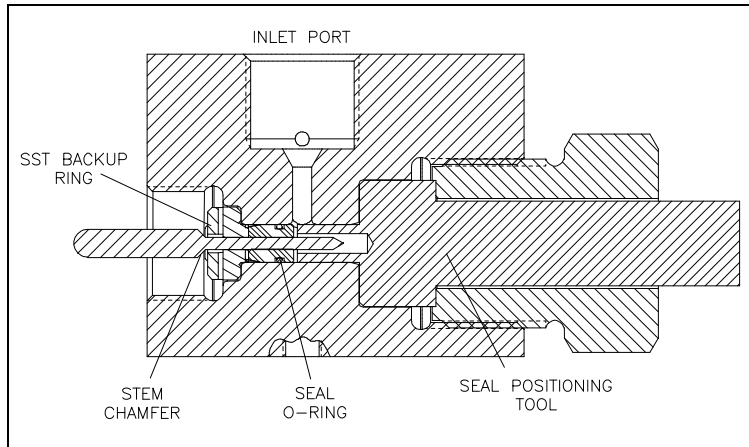

Do not push the o-ring on the seal assembly past the inlet port on the valve body. This will damage the seal o-ring.

Figure 9-31: Valve Stem Placement

18. Remove the high pressure bushing and the seal positioning tool.
19. Apply Pure Goop anti-seize compound to the threads of the actuator and carefully thread it into the valve body, guiding the stem head into the hole in the actuator. Turn the actuator clockwise until resistance is felt. Reverse the actuator 1/4-turn, and give it a quick spin clockwise to seat it. Hand-tighten only, 5 ft-lbs (7 Nm).
20. Apply Pure Goop anti-seize compound to all surfaces, except the ID, of a new valve seat. Install the seat into the opposite end of the valve body, inserting the small OD first.
21. Apply anti-seize compound to the threads on the high pressure bushing, and on the back side of the adapter cone. Position the adapter cone in the bushing, install the bushing and torque to 50 ft-lbs (68 Nm).
22. Replace the 1/4-inch gland nut and collar and torque to 25 ft-lbs (34 Nm).
23. Apply anti-seize compound to the threads on the 3/8-inch high pressure gland fitting. Install the collar and the gland fitting and torque to 50 ft-lbs (68 Nm).
24. Install the air supply hose and the electrical connection to the solenoid valve. Turn the air pressure to the actuator on and test the valve for leaks and proper operation.

Pneumatic Actuator

The following procedure is used to service the pneumatic actuator.

Figure 9-32: Pneumatic Actuator

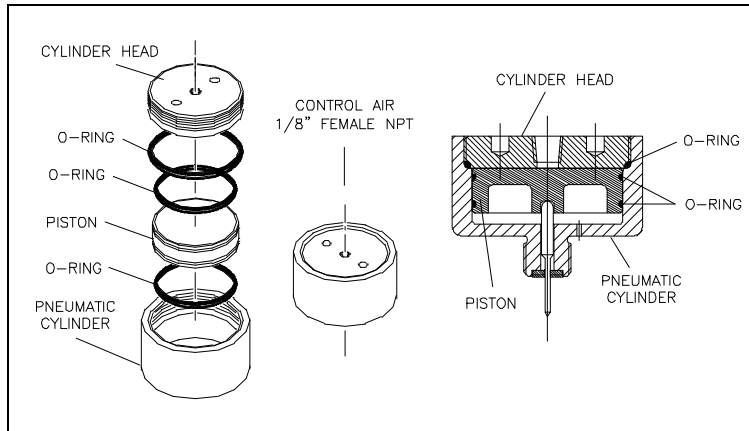

1. Unscrew and remove the cylinder head using a strap wrench and a pin spanner. Remove the piston from the cylinder.



Do not install the pneumatic cylinder in a vise to remove the cylinder head. This may distort the body and seize the piston, preventing proper operation.

2. Remove the o-ring on the cylinder head. Apply FML-2 grease to a new o-ring and install.
3. Remove the two o-rings on the piston. Apply FML-2 grease to two new o-rings and install.
4. Install the piston in the pneumatic cylinder. Apply anti-seize compound to the threads on the cylinder head and screw it into the pneumatic cylinder.

9.16 Weep Holes

High pressure seals and connections fail gradually and begin leaking slowly. Weep holes are located at every threaded high pressure connection to provide a vent for internal leaks. Water or oil dripping from a weep hole indicates one or more internal components are beginning to fail.

Table 9-3 lists the location of the weep hole, the possible source of the leak and the corrective action required.

Table 9-3
Weep Holes
High Pressure Water System

Location	Indication	Comments
Hydraulic Cylinder Head		
Hydraulic oil leaking from the weep hole in the hydraulic cylinder head	Failed hydraulic cartridge seal	Replace the cartridge seal. If the leak persists, check the plunger for linear scratches or scoring.
Water leaking from the weep hole on the hydraulic cylinder head flange	Failed high pressure seal assembly	Replace the high pressure seal assembly.
	Damaged plunger	Check the plunger for longitudinal scratches or flaws. If detected, replace the plunger or return to KMT for evaluation.
	Seal material buildup on plunger	Polish the plunger surface following the procedure, Plunger Maintenance.
	Damaged high pressure cylinder	
Check the inside diameter of the cylinder for expansion where the high pressure seal assembly is located. If detected, replace the cylinder.		



**Table 9-3
Weep Holes
High Pressure Water System**

Location	Indication	Comments
Sealing Head		
Water leaking from the weep hole in the sealing head	Seat in the discharge check valve is not sealing properly	Make sure the gland nut is tightened to the proper torque specification. Inspect the seat, sealing head and gland nut for cracks.
	Internal crack in sealing head	Replace the sealing head. <i>A cracked sealing head can result in water leaking from the high pressure outlet passage to the low pressure inlet passages.</i> <i>The sealing head body can become extremely hot.</i>
	Improper torque on gland nut	Tighten the gland nut to the proper torque specification.
	Erosion or scratches on the contact surface of the sealing head, or on the gland nut where the seat makes contact	Polish the surfaces following the procedure, Sealing Head Maintenance.
Water leaking from the weep hole in the gland nut	High pressure piping gland nut is not tight and is not sealing properly	Tighten the gland nut to the proper torque specification.
	Improper high pressure piping connection	Check the number of exposed threads past the collar on the high pressure piping. Only 1-1/2 to 2-1/2 threads should be exposed.
		Check high pressure piping for damage, cracks or deformation.
		Inspect the gland nut for deformation of the threads.
Damaged sealing head gland nut	Check the gland nut for cracks due to fatigue. If cracks are detected, replace the gland nut.	



Table 9-3
Weep Holes
High Pressure Water System

Location	Indication	Comments
Hard Seal End Cap		
Water leaking from the weep holes in the hard seal end cap	Damaged high pressure cylinder	Check for scratches or grooves on the 45-degree cone seal surface. If detected, polish to remove following the procedure, High Pressure Cylinder Maintenance.
	External crack in sealing head	Replace the sealing head.
	Damaged sealing head	Check for scratches or grooves on the 45-degree surface of the sealing head. If detected, polish the surface following the procedure, Sealing Head Maintenance.
	Improper torque on jackbolts	Re-torque the jackbolts to the proper torque specification.



SECTION 10

TROUBLESHOOTING

10.1 Overview

The troubleshooting guide will help identify the probable cause of a system malfunction and assist in providing corrective action. The following symptoms are discussed in this section:

1. High boosted water temperature
2. Booster pump pressure drop is greater than 30 psi (2 bar) during stroke condition
3. Outlet booster pump pressure is falling below 60 psi (4 bar)
4. Inlet water flow is poor and the filter housing is not filling completely
5. Water is leaking around the bleed valve on the filter head
6. High oil temperature resulting in shutdown
7. Low oil level resulting in shutdown
8. Restricted or no cooling flow
9. Hydraulic pressure but no high pressure water pressure
10. Erratic fluctuations in the operating pressure, or inability to reach or maintain set pressure
11. No hydraulic oil pressure
12. Pump shaft will not turn
13. Pump will not start
14. Console display and lights do not illuminate
15. Pump quits running
16. No control power
17. Red light on operator's console is flashing
18. Abnormal fluctuations in high pressure water signal
19. Hot surfaces on the high pressure cylinder components
20. Low cutting water supply pressure
21. Low cutting water pressure
22. Hydraulic oil leaking from the weep hole in the hydraulic cylinder head
23. Water leaking from the weep hole on the hydraulic cylinder head flange
24. Water leaking from the weep hole in the sealing head
25. Water leaking from the weep hole in the sealing head gland nut
26. Water leaking from the weep holes in the hard seal end cap

10.2 Troubleshooting Guide

Listen to the machine and observe it in operation. Learn to recognize the normal sounds and operating conditions of the system. Carefully define the symptom of the problem. Locate the symptom on the troubleshooting guide that most closely corresponds to the problem.

If the symptoms in the guide do not correspond to the malfunction, or if the problem is not resolved by the recommended corrective action, contact the KMT Customer Service Department for assistance.

Table 10-1
SL-V Series Troubleshooting Guide

	Malfunction	Indication	Comments
1.	High boosted water temperature	Orifice is blocked with debris	
		Long deadhead condition	
		Insufficient water supply	
		Booster pump temperature switch malfunction	
2.	Booster pump pressure drop is greater than 30 psi (2 bar) during stroke condition	Inlet water pressure or flow is low	
		Filter element is dirty and needs to be replaced	
		Booster pump is starting to fail	
3.	Outlet booster pump pressure is falling below 60 psi (4 bar)	Inlet water pressure is low	
		Filter element is dirty and needs to be replaced	
		Booster pump needs to be adjusted, or replaced	
4.	Inlet water flow is poor and the filter housing is not filling completely	Pipe sizing for inlet cutting water should be checked for pressure and flow	Cutting water supply will be lacking capacity or flow.
5.	Water is leaking around the bleed valve on the filter head	O-ring that closes the passage has deteriorated	A small o-ring under the valve can deteriorate causing the passage to remain open. The o-ring can be replaced by removing the screw and spring on the underneath side.

Table 10-1
SL-V Series Troubleshooting Guide

6.	Malfunction	Indication	Comments
6.	High oil temperature resulting in shutdown	Oil-to-Water Models	
		Cooling water flow is restricted	Check cooling water source for proper temperature and flow rate.
		Water modulating valve is stuck open or closed	Replace the valve.
		Scale build up in the heat exchanger has restricted the flow	The heat exchanger will need to be flushed or replaced.
		Oil-to-Air Models	
		Air cooler temperature switch is not operating properly	Replace the switch.
		No power to cooler fan motor	Check power supply to fan motor.
		Restricted air flow to cooler	
		Ambient temperature is greater than 100° F	
		Restricted oil flow to, from or inside the oil cooler	
7.	Low oil level resulting in shutdown		Check the level gauge.
			Check for hydraulic leaks.
			Check the level switch.
8.	Restricted or no cooling flow	Oil-to-Water Models	
		Check cooling water flow to and from the heat exchanger	The water pressure differential across the heat exchanger requires a minimum of 35 psi (2.4 bar) for flow through the exchanger.
		Water modulating valve is stuck or out of adjustment	Replace the valve. Adjust the valve.

Table 10-1
SL-V Series Troubleshooting Guide

Malfunction		Indication	Comments
9.	Hydraulic pressure but no high pressure water pressure	Proximity switch failure	From the Maintenance Screen on the control panel, jog the intensifier left and right and verify that the red light comes on at both proximity switches.
		I/O relay failure	From the Maintenance Screen on the control panel, jog the intensifier left and right and verify that the green light comes on at both directional valve solenoids.
		Coil failure on the directional control valve	Check the coils on the directional valve with a volt meter to verify if they are good or bad.
		PLC failure	If there are inputs from the proximity switches, but no outputs, contact the KMT Customer Service Department for a logic review and verification of PLC failure.
10.	Erratic fluctuations in the operating pressure, or inability to reach or maintain set pressure	The screen in the proportional pressure valve is blocked with debris	Remove the valve and clean the screen following the maintenance procedure in Section 7, Hydraulic System.
11.	No hydraulic oil pressure	The high and low limit compensators on the hydraulic pump are blocked with debris and are not controlling the swashplate	Disassemble the compensators, clean and inspect the components following the maintenance procedure in Section 7, Hydraulic System.
		Incorrect motor rotation	Check the motor rotation.
12.	Pump shaft will not turn	The flexible coupling has failed	Replace the flexible coupling.
		The hydraulic pump has seized	Replace the hydraulic pump.

Table 10-1
SL-V Series Troubleshooting Guide

	Malfunction	Indication	Comments	
13.	Pump will not start	Emergency stop button is depressed	Pull the e-stop button out.	
		Check all remote e-stop buttons.		
		Main power is disconnected	Check the main power and verify that the main power disconnect is on.	
		Control power has been interrupted	Check the power supply circuit for a tripped breaker.	
			Check the input and output of the 24 volt DC power supply.	
			Check the 2K1 relay.	
		A protection fault has been activated	Check the display panel for fault messages.	
Motor overload relay has been tripped	Identify the source of the overload and remedy the problem. Reset the overload relay.			
Inlet water valve is turned off	Press the reset button on the Run Screen to reset the water valve.			
14.	Console display and lights do not illuminate	Emergency stop button is depressed	Pull the e-stop button out.	
			Check all remote e-stop buttons.	
		Main power is disconnected	Check the main power and verify that the main power disconnect is on.	
			Control power is not available	Check the power supply circuit for a tripped breaker.
				Check the input and output of the 24 volt DC power supply.
				Check the 2K1 relay.

Table 10-1
SL-V Series Troubleshooting Guide

Malfunction		Indication	Comments
15.	Pump quits running	Unsafe operation has been detected	Check the display panel for fault messages.
		Electrical power has been interrupted	Check the power supply circuit for a tripped breaker.
			Check the input and output of the 24 volt DC power supply.
			Verify that power is available at the main power source.
			Check the 2K1 relay coil.
		Check the 4K0 relay.	
Motor overload relay has been tripped	Identify the source of the overload and remedy the problem. Reset the overload relay.		
16.	No control power	Circuit breaker has been tripped	Check the input and output of all circuit breakers.
		Power supply fault	Check the input and output voltages at the power supply.
		Emergency stop button is depressed	Pull the e-stop button out.
			Check all remote e-stop buttons.
		Master control relay is not energized	Verify that the contactor coil is pulling in on the master control relay.
Contact set failure on the master control relay	Verify that the contact sets on the master control relay are changing states when the relay is energized.		

Table 10-1
SL-V Series Troubleshooting Guide

	Malfunction	Indication	Comments
17.	Red light on operator's console is flashing	An alarm condition has occurred	<p>Check the display panel for fault messages.</p> <p><i>Refer to Section 4, Operation, for additional information regarding warning and alarm conditions and recovery procedures.</i></p>
18.	Abnormal fluctuations in high pressure water signal	Large, worn or damaged orifice	<p>Make sure the orifice does not exceed the capacity of the pump.</p> <p>Make sure the orifice is in good working condition. Verify that the jewel is installed in the orifice mount.</p>
		Check valve leakage	Inspect the discharge check valves in the sealing heads.
			Inspect the inlet check valves in the sealing heads.
		Seal leakage	Inspect the high pressure seal on the plunger.
			Inspect the sealing head-to-cylinder sealing surfaces.
		Hydraulic control malfunction	<p>Check the operation of the hydraulic relief valve.</p> <p>Verify that the directional control valve is shifting properly.</p> <p>Check the operation of the proximity switches.</p>

Table 10-1
SL-V Series Troubleshooting Guide

Malfunction		Indication	Comments
19.	Hot surfaces on the high pressure cylinder components	Leaking discharge check valve	Inspect the condition of the seat, poppet valve, spring, poppet pin and sealing head surface on the discharge end of the sealing heads.
		Leaking inlet check valve	Inspect the condition of the poppet valve, poppet retainer and the spring, if applicable, on the inlet end of the sealing heads.
		Damaged sealing head	Check the cone flange surface of the sealing head for scratches or mechanical damage and replace if necessary.
		Damaged high pressure cylinder	Check the high pressure cylinder for cracks.
20.	Low cutting water supply pressure	Restricted water supply	Check cutting water supply flow and pressure.
		Clogged water filter	Check the condition of the low pressure water filter and replace the filter element if necessary.
		Trapped air	Bleed the air from the cutting water plumbing.
21.	Low cutting water pressure	Low hydraulic pressure setting	If operating in low pressure, switch to high pressure operation and check the hydraulic pressure setting. <i>Not applicable when the machine is equipped with the optional proportional pressure control.</i>
			Clean the high pressure adjustment valve.
			Clean the compensators on the hydraulic pump.
		Collapsed element in the high pressure line filter	Check the element in the high pressure line filter.

Table 10-1
SL-V Series Troubleshooting Guide

Malfunction		Indication	Comments
22.	Hydraulic oil leaking from the weep hole in the hydraulic cylinder head	Failed hydraulic cartridge seal	Replace the cartridge seal. If the leak persists, check the plunger for linear scratches or scoring.
23.	Water leaking from the weep hole on the hydraulic cylinder head flange	Failed high pressure seal assembly	Replace the high pressure seal assembly.
		Damaged plunger	Check the plunger for longitudinal scratches or flaws. If detected, replace the plunger or return to KMT Waterjet for evaluation and rework.
		Seal material buildup on plunger	Polish the plunger surface following the procedure, Plunger Maintenance, detailed in Section 9, High Pressure Water System.
		Damaged high pressure cylinder	Check for scratches, grooves or material buildup on the inside diameter of the cylinder. If detected, polish the bore following the procedure, High Pressure Cylinder Maintenance, detailed in Section 9, High Pressure Water System.
			Check the inside diameter of the cylinder for expansion where the high pressure seal assembly is located. If detected, replace the cylinder.

Table 10-1
SL-V Series Troubleshooting Guide

	Malfunction	Indication	Comments
24.	Water leaking from the weep hole in the sealing head	Seat in the discharge check valve is not sealing properly	Make sure the gland nut is tightened to the proper torque specification.
			Inspect the seat, sealing head and gland nut for scratches, erosion or cracks.
		Improper torque on gland nut	Tighten the gland nut to the proper torque specification.
		Internal crack in sealing head	Replace the sealing head. <i>A cracked sealing head can result in water leaking from the high pressure outlet passages to the low pressure inlet passages.</i> <i>The sealing head body can become extremely hot.</i>
		Erosion or scratches on the contact surface of the sealing head, or on the gland nut where the seat makes contact	Polish the surfaces following the procedure, Sealing Head Maintenance, detailed in Section 9, High Pressure Water System.
25.	Water leaking from the weep hole in the sealing head gland nut	High pressure piping gland nut is not tight and is not sealing properly	Tighten the gland nut to the proper torque specification.
		Improper high pressure piping connection	Check the number of exposed threads past the collar on the high pressure piping. Only 1-1/2 to 2-1/2 threads should be exposed.
			Check high pressure piping for damage, cracks or deformation.
		Inspect the gland nut for deformation of the threads.	
Damaged sealing head gland nut	Check the gland nut for cracks due to fatigue. If cracks are detected, replace the gland nut.		

Table 10-1
SL-V Series Troubleshooting Guide

	Malfunction	Indication	Comments
26.	Water leaking from the weep holes in the hard seal end cap	Damaged high pressure cylinder	Check for scratches or grooves on the 45-degree cone seal surface. If detected, polish to remove following the procedure, High Pressure Cylinder Maintenance, detailed in Section 9, High Pressure Water System.
			Replace the high pressure cylinder.
		External crack in sealing head	Replace the sealing head.
		Damaged sealing head	Check for scratches or grooves on the 45-degree surface of the sealing head. If detected, polish the surface following the procedure, Sealing Head Maintenance, detailed in Section 9, High Pressure Water System.
		Improper torque on jackbolts	Re-torque the jackbolts to the proper torque specification.

10.3 Softstarter

A flashing red LED indicates a fault, either internal to the softstarter, or with the incoming power or motor. The number of flashes in sequence indicates the fault.

Table 10-2
Softstarter Troubleshooting Guide

1.	Pre-start Motor fails to start or Motor attempts to start, but aborts before up-to-speed	LED off	Check control power connections and the power source to the softstarter.
		LED on	Check isolation contactor for proper closure.
			Check presence of line power.
		LED flashing one time; overload	Reset overload.
		LED flashing two times; over temperature	Allow time for unit to cool.
		LED flashing four times; phase loss/open load	Check line and load connections to the softstarter, contactors and motor.
			Confirm that 3-phase is present.
LED flashing five times; phase imbalance	Check the line current present in each phase. <i>The unit will trip if imbalance is >50%.</i>		
LED flashing six times; shorted SCR	Perform continuity check across the power poles L1-T1, L2-T2, L3-T3. <i>Remove line power and load connections before taking measurements. Measurements should exceed 10k for good power pole.</i>		

Table 10-2
Softstarter Troubleshooting Guide

2.	Motor stops inadvertently and fails to start	LED off	Check control power connections and the power source to the softstarter.
		LED on	Check isolation contactor for proper closure.
			Check presence of line power.
		LED flashing one time; overload	Reset overload.
		LED flashing two times; over temperature	Allow time for unit to cool.
		LED flashing four times; phase loss/open load	Check line and load connections to the softstarter, contactors and motor.
			Confirm that 3-phase is present.
LED flashing five times; phase imbalance	Check the line current present in each phase. <i>The unit will trip if imbalance is >50%.</i>		
Note: The LED flashing seven times indicates the softstarter is performing a self-test.			



SECTION 11

SPECIFICATIONS

11.1 Overview

A comprehensive listing of specifications for the SL-V *Plus* models listed in Table 11-1 are provided in this section.

Table 11-1
SL-V *Plus* Models

Model	Motor Horsepower Rating	
	HP	Kw
SL-V 30	30	22
SL-V 50	50	37
SL-V 60	60	45
SL-V 75	75	56
SL-V 100	100	75
SL-V 100D	100	75

11.2 Installation Specifications

Environment

Installation location	Indoors
Air borne dust/contaminants	Minimal
Ambient temperature	
Minimum storage	36° F (2° C)
Minimum operating	40° F (5° C)
Maximum operating	104° F (40° C)
Maximum relative humidity* (at maximum operating temperature)	95%

***Note:** When the relative humidity is above 50%, the oil in the reservoir should be checked frequently for water content.



Sound Level

	30 HP	50 HP	60 HP	75 HP	100 HP	100D
Sound level [dB(A)]	72.5	72.5	77.5	77.5	77.5	77.5

Equipment Dimensions and Weights

Horsepower	Length	Width	Height	Weight
30 HP	67.98" (1,727 mm)	36.00" (914 mm)	57.19" (1,453 mm)	1,920 lbs (870 kg)
50 HP	67.98" (1,727 mm)	36.00" (914 mm)	57.19" (1,453 mm)	2,720 lbs (1,234 kg)
60 HP	67.98" (1,727 mm)	36.00" (914 mm)	57.19" (1,453 mm)	3,220 lbs (1,460 kg)
75 HP	77.75" (1,975 mm)	36.00" (914 mm)	57.19" (1,453 mm)	3,800 lbs (1,724 kg)
100 HP	77.75" (1,975 mm)	36.00" (914 mm)	57.19" (1,453 mm)	4,200 lbs (1,905 kg)
100D	77.75" (1,975 mm)	36.00" (914 mm)	57.19" (1,453 mm)	4,300 lbs (1,950 kg)

Redundant Models (*same dimensions as above*)

30 HP				2,200 lbs (998 kg)
50 HP				3,000 lbs (1,360 kg)
60 HP				3,500 lbs (1,588 kg)
75 HP				4,200 lbs (1,905 kg)
100 HP				4,600 lbs (2,087 kg)

Service Connections

	Connection	Height
A Drain	1/2" NPT	7.50" (191 mm)
B Cutting Water In	1/2" NPT	10.50" (267 mm)
C Cooling Water In (oil-to-water models) Hydraulic Oil In (air-to-water models)	1/2" NPT	13.50" (343 mm)
	3/4" JIC	
D Cooling Water Out (oil-to-water models) Hydraulic Oil Out (air-to-water models)	1/2" NPT	16.50" (419 mm)
	3/4" JIC	
E Plant Air In	1/4" NPT	32.00" (813 mm)
F Cutting Water Out	9/16" HP	36.00" (914 mm)
G Contaminated Waste Drain	1/2" NPT	41.00" (1,041 mm)

All service connections are made on the rear bulkhead of the machine. The intensifier requires two incoming water sources, cooling water and cutting water; two drain lines, cooling water and wastewater; a high pressure discharge line, and an air supply line.

Plant Air

The facility compressed air connection should provide clean, dry air regulated to 85 psi (5.9 bar). Air usage is minimal, normally less than 1 scf/m.

The following table provides specifications for each ISO air quality classification. KMT recommends adherence to Quality Class 4.

Table 11-2
ISO Air Quality Classifications

ISO Quality Class	Maximum Particle Size (microns)	Maximum Pressure Dew Point (water @ 100 psi)	Maximum Oil Content (Mg/m ³)
1	0.1	-94° F (-60° C)	0.01
2	1	-40° F (-40° C)	0.1
3	5	-4° F (-20° C)	1
4	15	+38° F (+3° C)	5
5	40	+45° F (+7° C)	25
6	--	+50° F (+10° C)	--

11.3 Water Specifications

Cutting Water Supply (Low Pressure Water System)

	30 HP	50 HP	60 HP	75 HP	100 HP	100D
Maximum consumption [gpm (L/min)]	2.5 (9.5)	4.0 (15.1)	4.5 (17.0)	6.0 (22.7)	8.0 (30.0)	8.0 (30.0)
Minimum inlet water pressure	35 psi (2.4 bar) flowing					
Maximum inlet water pressure	80 psi (5.5 bar)					
Maximum outlet water pressure	120 psi (8.3 bar)					
Booster pump factory set inlet pressure	58 psi (4 bar)					
Booster pump factory set outlet pressure	120 psi (8.3 bar)					
Optimum inlet water temperature	65° F (18° C)					
Maximum inlet water temperature	85° F (29° C)					
Low inlet water pressure	30 psi (2 bar)					
Low booster pressure	60 psi (4 bar)					
Booster pump overheat	128° F (53° C)					



Cooling Water Supply (Recirculation System)

	30 HP	50 HP	60 HP	75 HP	100 HP	100D
Reservoir capacity	40 gal (151 L)	40 gal (151 L)	40 gal (151 L)	48 gal (182 L)	48 gal (182 L)	48 gal (182 L)
Low oil level shutdown	28 gal (106L)	28 gal (106L)	28 gal (106L)	37 gal (140 L)	37 gal (140 L)	37 gal (140 L)
Maximum consumption at 75° F (24° C) [gpm (L/min)]	2.5 (9.5)	3.0 (11.4)	3.5 (13.2)	4.0 (15.1)	4.5 (17.0)	4.5 (17.0)
Total heat rejection	5.3 HP 4.0 kW	8.6 HP 6.4 kW	10.6 HP 7.9 kW	13.7 HP 10.2 kW	17.7 HP 13.2 kW	17.7 HP 13.2 kW

Minimum operating oil temperature	60° F (15° C)
Optimum operating oil temperature	115° F (46° C)
Hot oil shutdown (maximum operating oil temperature)	144° F (62° C)
Minimum inlet cooling water pressure (oil-to-water models)	35 psi (2.4 bar)
Maximum inlet cooling water pressure (oil-to-water models)	100 psi (6.9 bar)
Oil filtration rating (Beta filtration rating)	$\beta_{10} \geq 100^*$
Fluid cleanliness rating (ISO fluid cleanliness rating)	17/14**
Nominal recirculation pressure	30 psi (2 bar)

Recommended oil type

General service

Mobil DTE 26, Grade 68
Conoco Hydroclear™ multi-purpose
R&O

Food service

Fuchs/Geralyn AW68

* **Note:** For each particle per milliliter downstream of the filter greater than 10 microns, there are 100 particles per milliliter larger than 10 microns upstream of the filter.

****Note:** Indicates ISO 4406 range numbers for maximum permissible number of particles per milliliter, greater than 5 and 15 microns.

17 <1,300 particles per milliliter, >5 microns

14 <160 particles per milliliter, >15 microns

Water Quality Standards

The quality of the inlet cutting water supply is one of the most important factors affecting component life and performance. Water treatment requirements can be determined by a water analysis.

The cutting water supply must meet the following standards. A high concentration of dissolved solids, especially calcium, silica and chlorides will affect high pressure component life.

Table 11-3
Water Quality Standards

Constituent (mg/l or ppm)	Minimum Requirement	Better	Best
Alkalinity	50	25	10
Calcium	25	5	0.5
Chloride	100	15	1
Free Chlorine	1	1	0.05
Iron	0.2	0.1	0.01
Magnesium as Mg	0.5	0.1	0.1
Manganese as Mn	0.1	0.1	0.1
Nitrate	25	25	10
Silica	15	10	1
Sodium	50	10	1
Sulfate	25	25	1
TDS*	200	100	35**
Total Hardness	25	10	1
pH	6.5-8.5	6.5-8.5	6.5-8.5
Turbidity (NTU)	5	5	1

* **Note:** Total dissolved solids

****Note:** Do not reduce the TDS beyond this amount or the water will be too aggressive.

Table 11-4
Water Impurities

Constituent	Chemical Formula	Comments
Alkalinity	Bicarbonate (HCO ₃) Carbonate (CO ₃) Hydrate (OH), expressed as CaCO ₃	Acid neutralizing capacity of water. Foaming and carryover of solids, causes embrittlement of steel, can produce CO ₂ , a source of corrosion.
Calcium	Ca	When dissolved makes water hard; contributes to the formation of scale.
Chloride	Cl	Adds to solid content and increases corrosive character of water; in relative percentage presence with oxygen induces stress corrosion cracking.
Free Chlorine	Cl ₂	Oxidizing agent; can attack elastomeric seals and damage reverse osmosis (RO) membranes.
Iron	Fe ⁺⁺ (ferrous) Fe ⁺⁺⁺ (ferric)	Discolors water or precipitation; source of scale and erosion.
Magnesium as Mg		When dissolved makes water hard; contributes to the formation of scale.
Manganese as Mn	Mn ⁺⁺	Discolors water or precipitation; source of scale and erosion.
Nitrate	NO ₃	Adds to solid content; effect is not generally significant industrially.
Silica	SiO ₂	Causes scale
Sodium	Na	Found naturally; introduced to water in the ion exchange water softening process.
Sulfate	SO ₄	Adds to solid content; combines with calcium to form calcium sulfate scale.
TDS		Measure of the total amount of dissolved matter in water.
Total Hardness	CaCO ₃	Sum of all hardness constituents in water; typically expressed as their equivalent concentration of calcium carbonate; primarily due to calcium and magnesium in solution, but may include small amounts of metal. Carbonate hardness is usually due to magnesium and calcium bicarbonate; non-carbonate hardness is due to sulfates and chlorides.
pH		Intensity of the acidic or alkaline solids in water; pH scale runs from 0, highly acidic, to 14, highly alkaline; with 7 being neutral.



11.4 Electrical Specifications

Electrical System

Motor type	TEFC (Totally Enclosed Fan Cooled)
Controls	
Voltage	24 volts DC
Power supply	10 amps DC

Ampacity and Power Voltage Requirements

Power Voltage	Motor Horsepower	Full Load Amps	Circuit Breaker Amps
208/3/60	30	80	125
230/3/60	30	76	100
400/3/50	30	43	60
415/3/50	30	43	60
460/3/60	30	38	50
575/3/60	30	32	40
200/3/50-60	50	132	175
200/3/50-60	50	132	175
208/3/50-60	50	128	175
230/3/60	50	116	150
380/3/50	50	69	100
400/3/50	50	66	100
415/3/50	50	64	100
460/3/60	50	58	80
575/3/60	50	52	70
230/3/60	60	140	175
380/3/60	60	86	125
460/3/60	60	70	90
200/3/50	75	196	250
230/3/60	75	172	250
400/3/50	75	98	125
460/3/60	75	86	125
200/3/50-60	100	248	350



Ampacity and Power Voltage Requirements

Power Voltage	Motor Horsepower	Full Load Amps	Circuit Breaker Amps
200-208/3/50-60	100	248/242	350
230/3/60	100	218	300
400/3/50	100	124	175
415/3/50	100	121	175
460/3/60	100	109	175
575/3/60	100	99	125

11.5 Hydraulic and High Pressure Water System Specifications

Hydraulic System

	30 HP	50 HP	60 HP	75 HP	100 HP	100D
Maximum operating pressure	3,000 psi (207 bar)			2,600 psi (179 bar)		
Main system relief valve	3,408 psi (235 bar)			2,973 psi (205 bar)		

High Pressure Water System

	30 HP	50 HP	60 HP	75 HP	100 HP	100D
Plunger diameter [inches (mm)]	0.875 (22)	0.875 (22)	0.875 (22)	1.125 (29)	1.125 (29)	0.875 (22)
Piston diameter [inches (mm)]	4.03 (102.4)	4.03 (102.4)	4.03 (102.4)	5.50 (139.7)	5.50 (139.7)	4.03 (102.4)
Intensification ratio	20:1	20:1	20:1	23:1	23:1	20:1
Maximum flow rate						
55,000 psi (3,792 bar) [gpm (L/min)]	0.60 (2.27)	1.00 (3.79)	1.12 (4.24)	1.44 (5.45)	2.00 (7.57)	2.00 (7.57)
60,000 psi (4,137 bar) [gpm (L/min)]	0.52 (1.97)	0.90 (3.41)	1.02 (3.86)	1.34 (5.07)	1.88 (7.12)	1.88 (7.12)
Minimum outlet pressure	5,800 psi (400 bar)	5,800 psi (400 bar)	5,800 psi (400 bar)	6,700 psi (462 bar)	6,700 psi (462 bar)	5,800 psi (400 bar)
Maximum outlet pressure	60,000 psi (4,137 bar)					



High Pressure Water System

	30 HP	50 HP	60 HP	75 HP	100 HP	100D
Pneumatic Control Valve						
Maximum water pressure						60,000 psi (4,137 bar)
Minimum air pressure						85 psi (5.9 bar)
Maximum air pressure						100 psi (6.9 bar)
Maximum flow rate						1.0 cfm (0.028) m ³ /min

Orifice Capacity

The following tables provide horsepower requirements for some of the more popular orifices.

Table 11-5
Single Orifice Diameter

Model	Motor Horsepower Rating		Maximum Operating Pressure	Maximum Single Orifice Diameter (at full pressure)
	HP	Kw		
SL-V 30	30	22	60,000 psi (4,137 bar)	0.010 inch (0.254 mm)
SL-V 50	50	37		0.013 inch (0.330 mm)
SL-V 60	60	45		0.014 inch (0.356 mm)
SL-V 75	75	56		0.016 inch (0.406 mm)
SL-V 100	100	75		0.019 inch (0.483 mm)
SL-V 100D	100	75		0.019 inch (0.483 mm)



**Table 11-6
Horsepower Requirements**

Orifice Size inches (mm)	45,000 psi (3,103 bar)	50,000 psi (3,447 bar)	55,000 psi (3,792 bar)	60,000 psi (4,137 bar)
0.003 (0.076)	1.7	2.0	2.3	2.6
0.004 (0.102)	3.0	3.5	4.0	4.6
0.005 (0.127)	4.6	5.4	6.2	7.1
0.006 (0.152)	6.7	7.8	9.0	10.2
0.007 (0.178)	9.1	10.6	12.2	13.9
0.008 (0.203)	11.8	13.9	16.0	18.2
0.009 (0.229)	15.0	17.5	20.2	23.0
0.010 (0.254)	18.5	21.6	25.0	28.5
0.011 (0.279)	22.4	26.2	30.2	34.4
0.012 (0.305)	26.6	31.2	36.0	41.0
0.013 (0.330)	31.2	36.6	42.2	48.1
0.014 (0.356)	36.2	42.4	48.9	55.8
0.015 (0.381)	41.6	48.7	56.2	64.0
0.016 (0.406)	47.3	55.4	63.9	77.8
0.017 (0.432)	53.4	62.6	72.2	82.2
0.018 (0.457)	59.9	70.1	80.9	92.2
0.019 (0.483)	66.7	78.1	90.1	102.7
0.020 (0.508)	73.9	86.6	99.9	113.8
0.021 (0.533)	81.5	95.4	110.1	125.5
0.022 (0.559)	89.4	104.8	120.9	137.7
0.023 (0.584)	97.8	114.5	132.1	150.5

The horsepower requirements for operating multiple orifices are determined by adding the requirements in Table 11-6 for each orifice. Examples are shown below.

Orifice Size inches (mm)	Number of Orifices	Operating Pressure	Calculation	Total Horsepower
0.009 (0.229)	3	55,000	3 x 20.2	60.6
0.015 (0.381)	1	50,000	48.7 + 21.6	70.3
0.010 (0.254)	1			

11.6 Torque Specifications

Measurements are made with lubricated components and a certified, calibrated torque wrench. Inconsistencies in wrench settings, lubrication and technique may not produce a leak free seal. If leakage occurs, the torque can be increased to seal the components. However, **do not exceed the recommended torque value by more than 15 percent**. If leakage persists, there is a component problem.



Excessive torque can cause component damage or failure, resulting in potential hazards to equipment and personnel.

Torque Specifications

	7/8 inch (22 mm) Diameter Plunger	1-1/8 inch (29 mm) Diameter Plunger
Hard Seal End Cap		
Jackbolts	6 (7/16") each	8 (7/16") each
1st Stage	Hand Tight	Hand Tight
2nd Stage	20 ft-lbs (27 Nm) Crossing Pattern	20 ft-lbs (27 Nm) Crossing Pattern
3rd Stage	32-35 ft-lbs (43-47 Nm)* Crossing Pattern	32-35 ft-lbs (43-47 Nm)* Crossing Pattern
4th Stage	32-35 ft-lbs (43-47 Nm)* Clockwise Pattern From Bolt 1	32-35 ft-lbs (43-47 Nm)* Clockwise Pattern From Bolt 1
Socket Wrench Size	3/8 inch	3/8 inch

6-Bolt Crossing Pattern

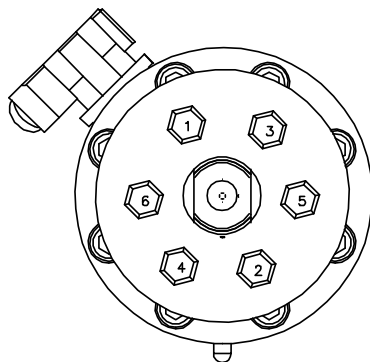

8-Bolt Crossing Pattern

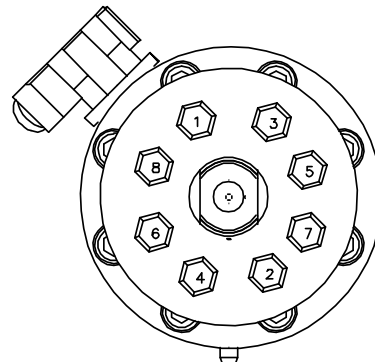

* **Note:** A maximum torque of 38 ft-lbs (51 Nm) is etched on the hard seal end cap. This represents the **maximum** allowable torque, not the recommended torque.



Torque Specifications

	7/8 inch (22 mm) Diameter Plunger	1-1/8 inch (29 mm) Diameter Plunger
Hydraulic Cylinder Head		
Socket Head Screws	8 (14M) each	6 (3/4") each
Torque	75-80 ft-lbs (102-108 Nm)	170-175 ft-lbs (230-237 Nm)
Hex Key	M12	5/8 inch
Proximity Switch		
Socket Head Screws	2 (M6) each	2 (1/4") each
Torque	140-160 in-lbs (16-18 Nm)	140-160 in-lbs (16-18 Nm)
Hex Key	M5	3/16 inch
Stem Mount		
Socket Head Screws	4 (M10) each	4 (3/8") each
Torque	60-65 ft-lbs (80-88 Nm)	35-40 ft-lbs (47-54 Nm)
Hex Key	M8	5/16 inch
Sealing Head		
Discharge Gland Nut	130 ft-lbs (176 Nm)	200 ft-lbs (271 Nm)
Poppet Retainer	30 in-lbs (3.4 Nm)	25-30 in-lbs (2.8-3.4 Nm)
3-Port Pneumatic Valve		
HP Adapter		25 ft-lbs (34 Nm)
1/4-inch Outlet to Drain		25 ft-lbs (34 Nm)
Pneumatic Actuator		5 ft-lbs (7 Nm)
3/8-inch HP Gland Nut		50 ft-lbs (68 Nm)
2-Port Pneumatic Valve		
3/8-inch HP Gland Nut		50 ft-lbs (68 Nm)
1/4-inch HP Gland Nut		25 ft-lbs (34 Nm)
Pneumatic Actuator		5 ft-lbs (7 Nm)
9/16"-1/4" HP Bushing		50 ft-lbs (68 Nm)
High Pressure Fittings		
1/4-inch Gland Nut		25 ft-lb (34 Nm)
3/8-inch Gland Nut		50 ft-lb (68 Nm)
9/16-inch Gland Nut		110 ft-lb (149 Nm)



SECTION 12 PARTS LIST

12.1 Overview

This section contains a comprehensive list of all standard and optional parts for the 75 horsepower SL-V *Plus*, maintenance tools, installation and equipment accessories. To facilitate the ordering of replacement parts, item numbers in each table correspond to the identifying numbers in the accompanying figures.

Use the following information to contact the Customer Service Department at KMT Waterjet Systems.

USA

Customer Service Department
KMT Waterjet Systems
PO Box 231
635 West 12th Street
Baxter Springs, KS 66713-0231
USA

Phone (800) 826-9274
Fax (620) 856-2242
Email wj.service@kmtwaterjet.com
wj.parts@kmtwaterjet.com

Europe

Spare Parts Manager
KMT Waterjet Systems GmbH
Wasserstrahl Schneidetechnik
Auf der Laukert 11
D-61231 Bad Nauheim
Germany

Phone +49-6032-997-119
Fax +49-6032-997-271
Email order.spares@kmt-waterjet.com



12.2 Index

Part lists are arranged in the following sequence:

Parts List Index

Table	Description	Part Number	Page	Table	Description	Part Number	Page
12-1	75 HP Intensifier Unit		12-4	12-13	Reservoir Assembly	05104153	12-26
12-2	Intensifier Assembly	72122493	12-6	12-14	Bulkhead Pipe Assembly	80079668	12-28
12-3	Hydraulic Cartridge Seal	05146584	12-8	12-15	Cover Assembly	80074768	12-31
12-4	Sealing Head Assembly	80072341	12-9	12-16	Electrical Assembly	80077936	12-33
12-5	Pneumatic Valve/Actuator Assembly	10184760	12-10	12-17	Controls Subassembly	80077845	12-35
12-6	Hydraulic Piston Assembly	05146576	12-12	12-18	Control Panel Configuration	80077944	12-38
12-7	High Pressure Piping	20429831	12-14	12-19	Control Panel Configuration	20471164	12-40
12-8	Low Pressure Water Filter Assembly	80087976	12-16	12-20	Proportional Pressure Control	80075732	12-42
12-9	Hydraulic Power Package	80077225	12-18	12-21	High Pressure Transducer	20431959	12-44
12-10	Motor/Pump Assembly	20412666	12-20	12-22	Redundant Kit	20431316	12-46
12-11	Hydraulic Manifold Assembly	49835796	12-22				
12-12	Hydraulic Hose Connections	05142351	12-24				



Parts List Index

Table	Description	Part Number	Page	Table	Description	Part Number	Page
12-23	High Pressure Tube Coning Tools		12-48	12-32	Autoline™ Abrasive Nozzle Assembly		12-65
12-24	High Pressure Tube Threading Tools		12-49	12-33	Autoline II™ Abrasive Nozzle Assembly		12-66
12-25	Maintenance Tools and Lubricants		12-50	12-34	Autoline™ Sapphire Orifice		12-67
12-26	Focusing Tubes		12-52	12-35	Autoline™ Diamond Orifice		12-67
12-27	Standard Sapphire Orifice		12-54	12-36	Pneumatic Control Valve, NC	10138824	12-68
12-28	Standard Diamond Orifice		12-54	12-37	Pneumatic Cylinder Assembly, NC	10177855	12-69
12-29	High Pressure Filter Assemblies		12-55	12-38	Pneumatic Control Valve, NO	10184760	12-70
12-30	High Pressure Swivel Joints		12-57	12-39	Pneumatic Cylinder Assembly, NO	10189553	12-71
12-31	Nozzle Tubes		12-63	12-40	Bulk High Pressure Tubing		12-72
				12-41	High Pressure Fitting and Valve Assemblies		12-73



Table 12-1
SL-V 75 Horsepower Intensifier Unit

Item	Part Number	Description	Quantity
1	20429831	High Pressure Piping Assembly	1
2	80077936	Electrical Assembly	1
3	20431316	Redundant Kit (Optional)	1
4	20461194	Decal Package, 75 Horsepower Single	1
5	05128087	Startup Tag	1
6	80079668	Bulkhead Pipe Assembly	1
7	05141569	Frame Assembly	1
8	05104153	Reservoir Assembly	1
9	80074768	Cover Assembly	1
10	80077225	Hydraulic Power Package	1
11	05142351	Hydraulic Hose Connections	1
12	20461257	Striping, Red	45.0"
13	10097657	Button Head Screw, 1/4-20 x 3/4	4
14	95391322	Flat Washer, .25	4
15	95838314	Lock Washer, .25	4

Figure 12-1: SL-V 75 Horsepower Intensifier Unit

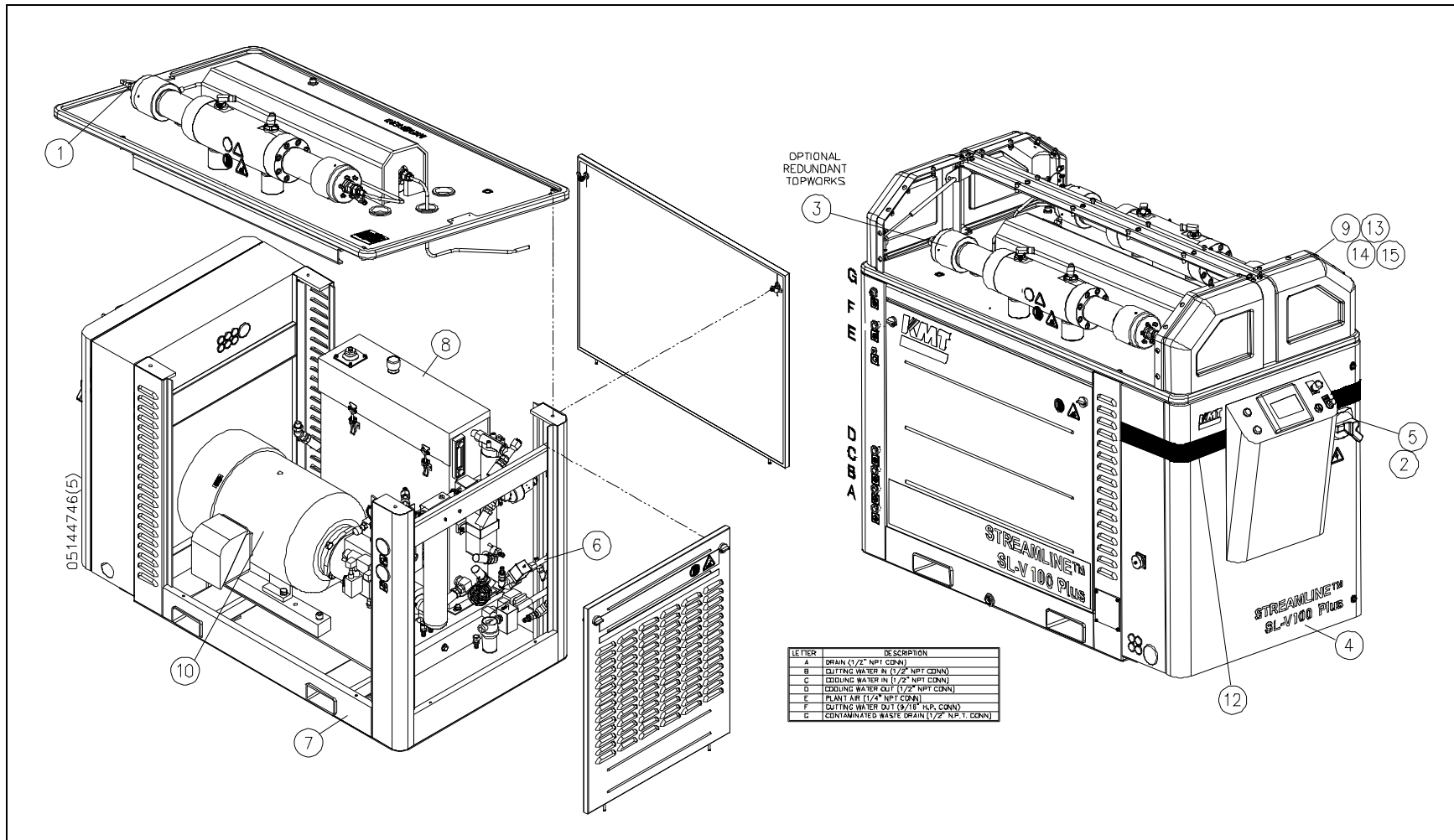



Table 12-2
Intensifier Assembly
72122493

Item	Part Number	Description	Quantity	Item	Part Number	Description	Quantity
1	72119536	HP Cylinder	2	15	05144514	Hydraulic Cylinder	1
2	05144506	Ceramic Plunger	2	16	05120092	Backup Ring, 5.25 x 5.50	2
3	80072341	Sealing Head Assembly	2	17	10074771	O-Ring, 5.25 x 5.50 x .13	2
4	20416445	Hydraulic Cylinder Head	2	18	20413955	Socket Head Screw, 3/4-16 x 3-1/4	12
5	05149711	HP Seal Assembly	2	19	05130224	Proximity Switch, 20-250V AC/DC	2
6	05144597	Spacer, Sealing Head	2	20	95119012	Socket Head Screw, 1/4 x 20 x 1	4
7	49838220	HP Cylinder Nut, HSEC	2	21	05146576	Piston Assembly	1
8	05146584	Hydraulic Cartridge Seal Assembly	2	23	05144522	Stem	2
9	05145099	Bushing Retainer Flange	2	25	05041058	Socket Head Screw, 3/8-16 x 2-1/4	8
11	05144555	Liner, HP Cylinder	2	26	95688743	Lock Washer, .38	8
12	10074920	O-Ring, 1.75 x .94 x .09	4	27	10118206	O-Ring, 1.31 x 1.56 x .13	2
13	80070352	Jackbolt, 7/16-20 x 2.31	16	28	05144183	Spacer, Proximity Switch	2
14	05034798	Retaining Ring	2	29	05146592	Gasket, Topworks Support	2

Figure 12-2: Intensifier Assembly

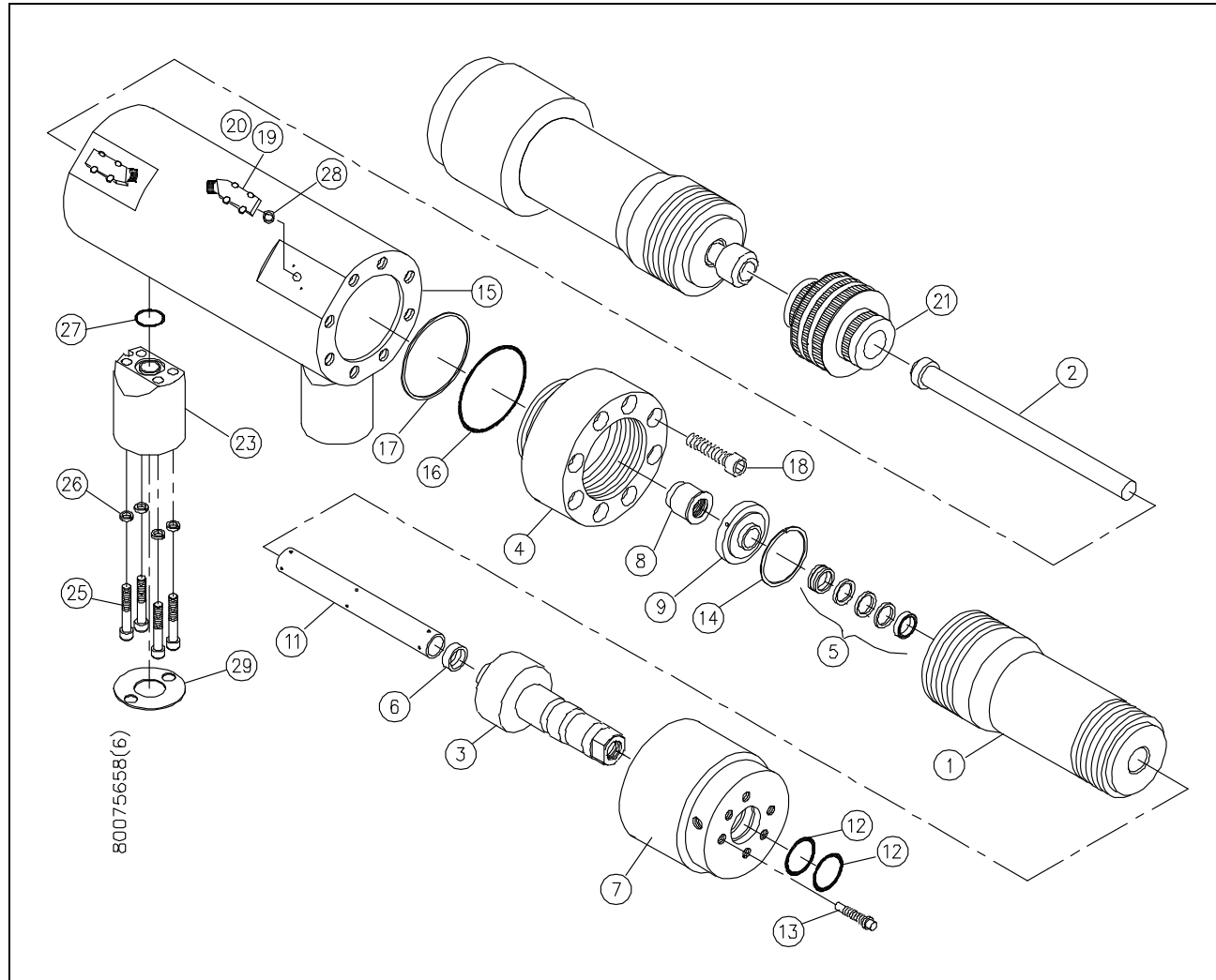

Table 12-3
Hydraulic Cartridge Seal
05146584

Item	Part Number	Description	Quantity	Item	Part Number	Description	Quantity
1	05144530	Seal Bushing	1	5	10168912	O-Ring, 1.25 x 1.38 x .06	1
2	10142032	Packing Ring, 1.38 x 1.13 x .25	2	6	05116124	O-Ring, 1.50 x 1.63 x .06	1
3	10145431	O-Ring, 1.44 x 1.63 x .09	1	7	05116132	U-Cup Seal, 1.13 x 1.38 x .13	1
4	05116140	Backup Ring, 1.44 x 1.63	1				
	80085061	Rebuild Kit					
		Includes Items 2-7					

Figure 12-3: Hydraulic Cartridge Seal

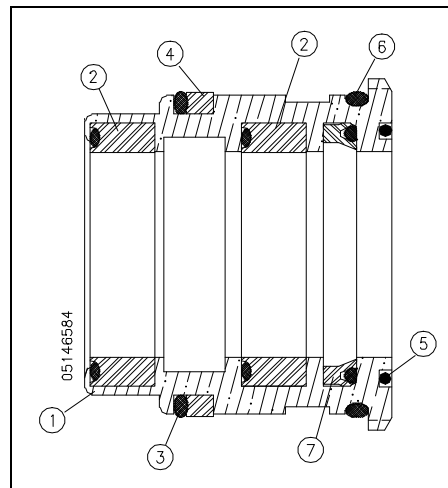

Table 12-4
Sealing Head Assembly
80072341

Item	Part Number	Description	Quantity	Item	Part Number	Description	Quantity
1	80071293	Sealing Head Body	1	5	05116603	Discharge Poppet Valve	1
2	05119680	Inlet Poppet Valve	1	6	05119698	Poppet Retainer	1
3	05116595	Gland Nut	1	7	05147863	Compression Spring	1
4	05116579	Seat	1	8	05119839	Poppet Pin	1
	80084403	Rebuild Kit					
		Includes Items 4, 5, 7 and 8					

Figure 12-4: Sealing Head Assembly

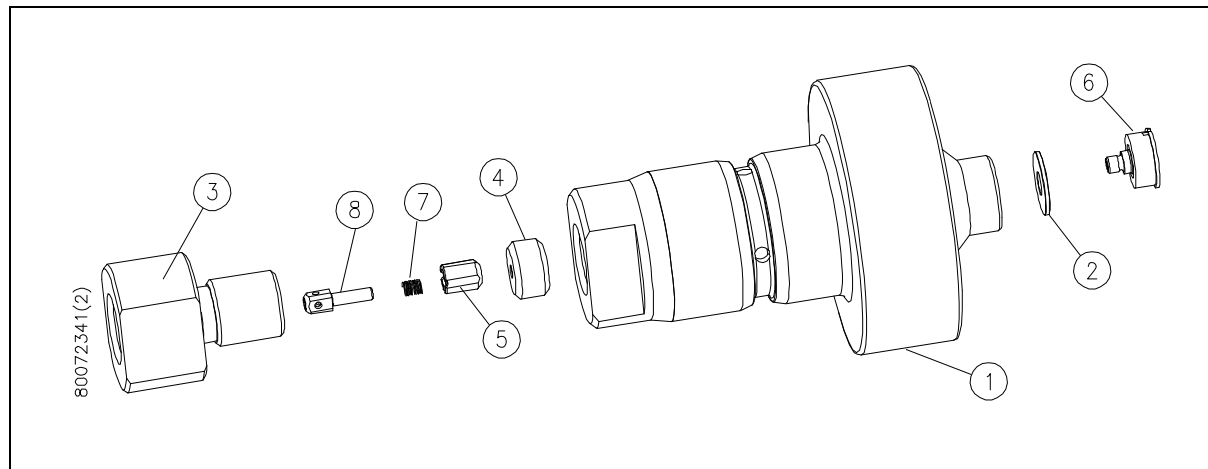



Table 12-5
Pneumatic Valve/Actuator Assembly, Normally Open
10184760

Item	Part Number	Description	Quantity	Item	Part Number	Description	Quantity
1	10189181	Valve Body	1		10189553	Actuator Assembly, Normally Open	
2	10178697	Valve Seat	1	6	BV401184	Pneumatic Cylinder	1
3	20435636	Valve Stem	1	7	BV601184	Cylinder Head	1
4	10188233	Backup Ring, Brass	1	8	BV501184	Piston	1
5	20428052	Seal Assembly	1	9	10187250	Backup Ring, SST	1
				10	10074714	O-Ring, 2.44 x 2.63 x .09	1
				11	10074565	O-Ring, 2.25 x 2.38 x .06	2
	05116017	Rebuild Kit					
		Includes Items 2, 3, 4, 5, 10 and 11					

Figure 12-5: Pneumatic Valve/Actuator Assembly, Normally Open

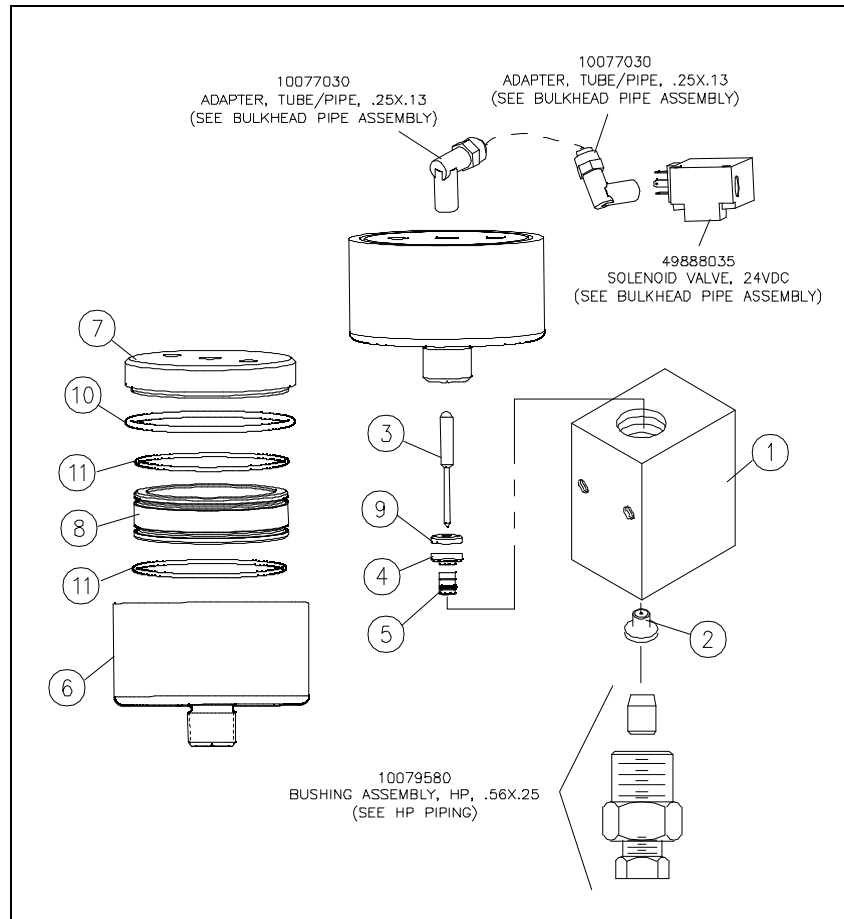



Table 12-6
Hydraulic Piston Assembly
05146576

Item	Part Number	Description	Quantity
1	05144589	Hydraulic Ram Piston	1
2	05074380	Plunger Retainer Pin, Clevis	12
3	05049887	Set Screw, Socket, 3/8-16 x 3/8	2
4	10148757	Check Valve	2
5	49877509	Adhesive, Thread Locker	--
6	05130216	Flat Snap Ring, .032 x .375 x 2.20	2
7	05146568	Backup Ring, 1.50 x 1.75 x .125	2
8	10074821	O-Ring, 1.50 x 1.75 x .13	2
9	05120118	Seal Assembly	1
10	05120100	Bearing Ring	2

80085079 Rebuild Kit

Includes Items 4, 6, 7, 8, 9 and 10

Figure 12-6: Hydraulic Piston Assembly

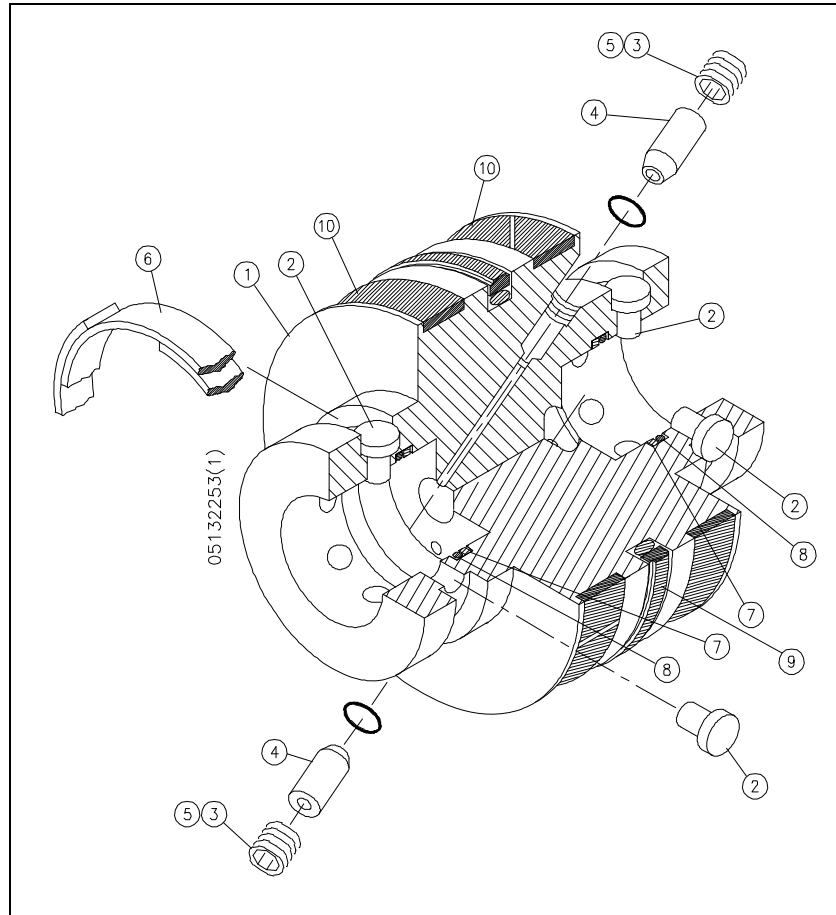



Table 12-7
High Pressure Piping
20429831

Item	Part Number	Description	Quantity	Item	Part Number	Description	Quantity
1	72122493	Intensifier Assembly	1	18	10184760	Pneumatic Valve/Actuator Assembly	1
2	20413237	Attenuator Assembly	1	19	10078608	HP Gland, .56	3
3	20417180	SST Tube	1	20	10079580	Bushing, HP, .56 x .25	1
4	05144837	Spacer, Attenuator Bracket	4	21	05086905	Conduit, .63	180.0"
5	10079465	Tee, HP, .56	2	22	10078913	HP Gland, Anti-Vibration, .38	1
6	05131347	Ferrule, .50 Hose	10	24	05112552	HP Tube, .25 x 34.0	1
7	05112057	HP Tube, .56 x 4.97	1	25	10079705	Coupling, HP Bulkhead, .56 x .56	1
8	10078525	Elbow, HP, .56 x .56	7	26	95413696	Lock Washer, .50	4
9	49895642	HP Tube, .56 x 9.25	1	27	95383790	Socket Head Screw, 1/2-13 x 1	4
10	10069326	HP Tube, .56 x 4.0	5	28	10079119	HP Collar, .56	3
11	05145271	HP Tube, .56 x 55.19	1	29	20424324	Attenuator Housing	1
12	05145297	HP Tube, .56 x 4.18	1	30	95375473	Socket Head Screw, 3/8-16 x 1	8
13	20429847	HP Tube, .56 x 16.34	1	31	95670972	Lock Washer, .38	8
14	05074661	HP Tube, .56 x 4.59	1	32	95660957	Flat Washer, .38	8
15	05109939	HP Tube, .56 x 10.7	1	33	05103023	PED Decal	1
16	10079457	Bushing, HP, .56 x .38	1	34	10078715	HP Collar, .38	1
17	10094704	HP Tube, .38 x 3.0	1	35	49898729	Flat Washer, M12	4

Figure 12-7: High Pressure Piping

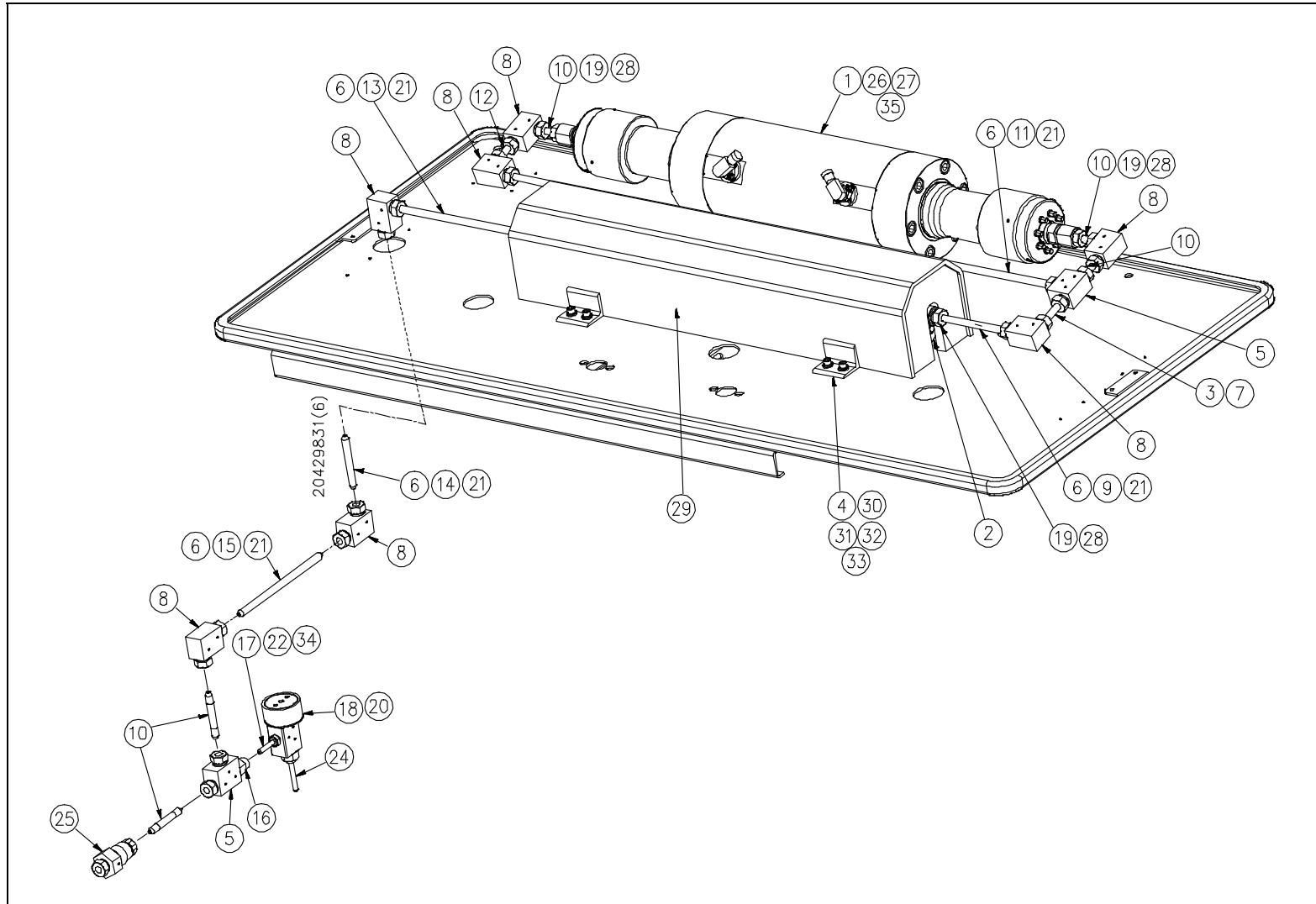



Table 12-8
Low Pressure Water Filter Assembly
80087976

Item	Part Number	Description	Quantity	Item	Part Number	Description	Quantity
3	05070982	Relief Valve, 50-150 psi	1	11	05135652	Check Valve	1
4	49838386	Pipe Nipple, .75 x 4.0	2	12	49833882	Adapter, Hose/ORB, .50 x .50	3
5	10119253	Elbow, Pipe, .50 x .50	1	13	95838314	Lock Washer, .25	4
6	20413848	Low Pressure Manifold, Outlet	1	14	49834716	Filter Element, 10 Micron	1
7	49833924	Low Pressure Manifold, Left	1	15	95391322	Flat Washer, .25	4
9	49835804	Adapter, Hose/Pipe, .50 x .50	2	16	10083384	U-Bolt, .75	2
10	72118339	Filter Housing Assembly	1	Ref 1	05073630	Mounting Bracket	--

Figure 12-8: Low Pressure Water Filter Assembly

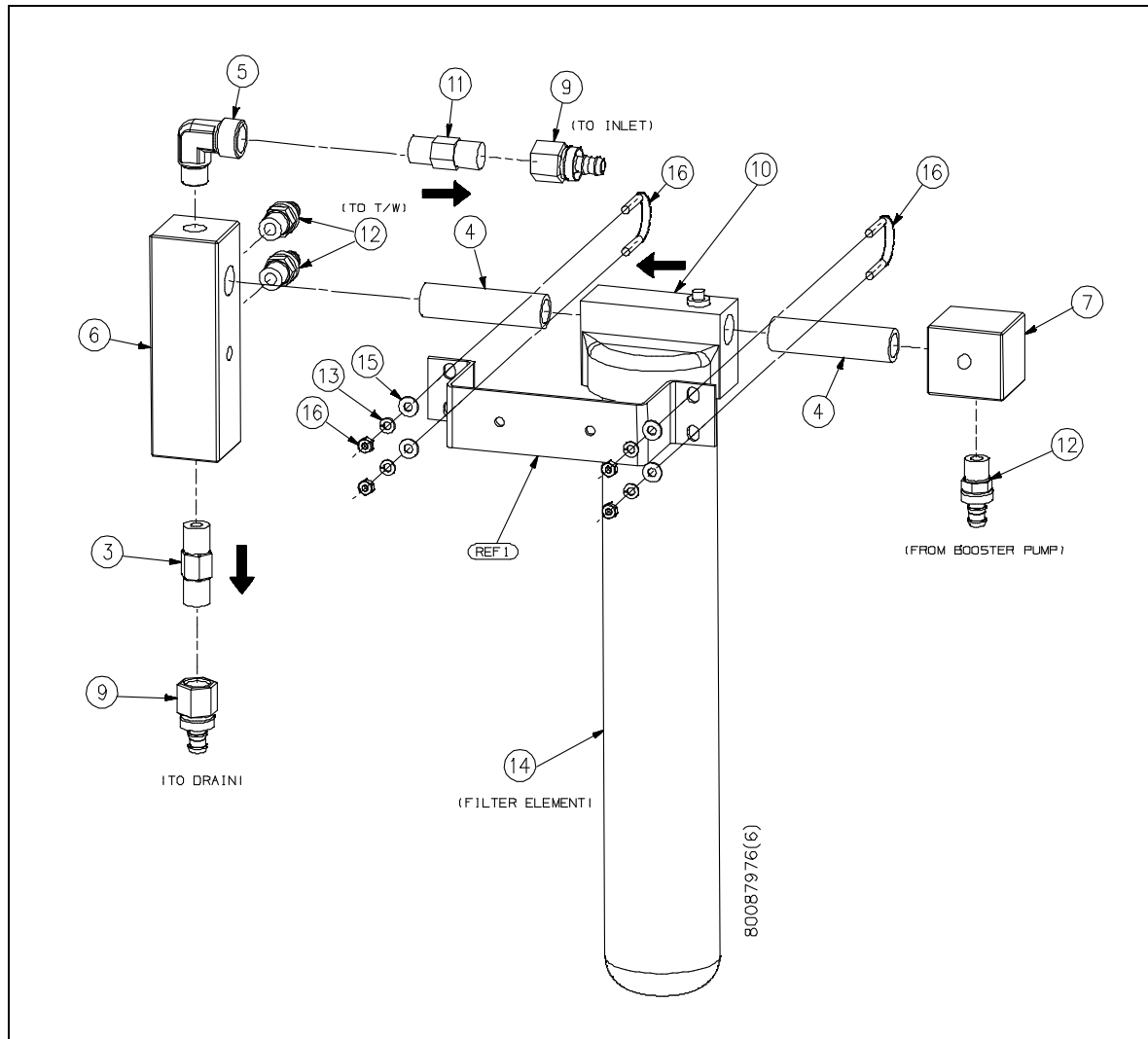
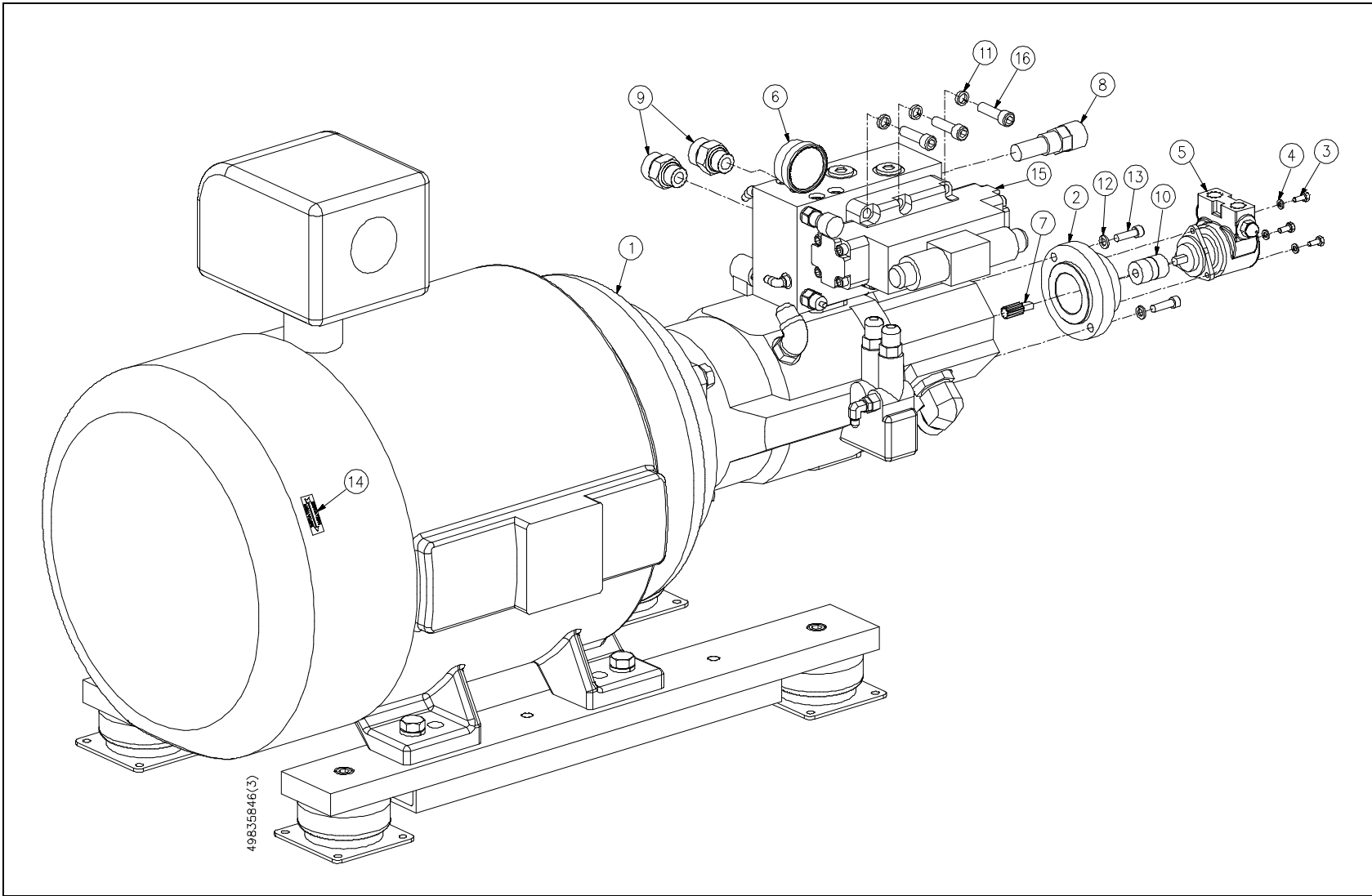



Table 12-9
Hydraulic Power Package
80077225

Item	Part Number	Description	Quantity
1	20412666	Motor/Pump Assembly, 75 HP	1
2	05103411	Adapter, Water Pump	1
3	95572897	Hex Head Screw, 1/4-20 x 5/8	3
4	95838314	Lock Washer, .25	3
5	49836778	Water Pump, Vane	1
6	49835754	Pressure Gauge, 0-5000 psi	1
7	05103429	Shaft Spline	1
8	80081733	Relief Valve, 205 Bar	1
9	80079684	Adapter, FSOR/ORB, 1.0 x .75	2
10	05103395	Shaft Coupling	1
11	95688750	Lock Washer, .50	6
12	95750394	Lock Washer, .38	2
13	05041033	Socket Head Screw, 3/8-16/3 x 1-1/4	2
14	10091510	Arrow Decal	1
15	20437206	Directional Control Valve, 24V DC	1
16	95055059	Socket Head Screw, 1/2-13 x 2-1/2	6

Figure 12-9: Hydraulic Power Package



49835846(3)



Table 12-10
Motor/Pump Assembly
20412666

Item	Part Number	Description	Quantity	Item	Part Number	Description	Quantity
1	10066207	Hex Head Screw, 5/8-11 x 2-3/4	4	15	05103247	Socket Head Screw, 1/2-13 x 6	4
2	95688735	Lock Washer, .75	4	16	95688750	Lock Washer, .50	4
3	05103205	Motor Mount	2	17	49882087	O-Ring, 1.88 x 2.13 x .13	1
4	80076607	Electric Motor, 75 HP	1	18	05112727	O-Ring, Pump Seal	1
5	95423679	Hex Head Screw, 5/8-11 x 1-3/4	4	19	05085758	Adapter, ORB/JIC, .38 x .25	1
6	80076656	Flange, Motor/Pump Adapter	1	20	10091163	Adapter, JIC/ORB, .75 x .75	1
7	80077076	Piston Pump	1	21	10118057	Plug, ORB, .75	1
8	10192961	Socket Head Screw, M12 x 1.75 x 30 mm	2	22	10099760	Adapter, JIC/ORB, 1.25 x 1.25	1
9	10069763	Flat Washer, .50	2	23	05139639	Bushing, ORB, M14 x .25	1
10	49835796	Manifold Assembly	1	24	20413599	Coupling, Pump Shaft	1
11	10151470	Adapter, ORB/JIC, 1.0 x .75	1	25	20413617	Flexible Drive Insert	1
12	05091301	Gear Pump	1	26	80085483	Spacer Block	4
13	05084371	Socket Head Screw, 5/8-11 x 3-1/2	4	27	95055281	Socket Head Screw, 3/8-16 x 1-1/2	4
14	05103254	Vibration Isolation Mount	4	28	80076573	Coupling, Motor Shaft	1

Figure 12-10: Motor/Pump Assembly

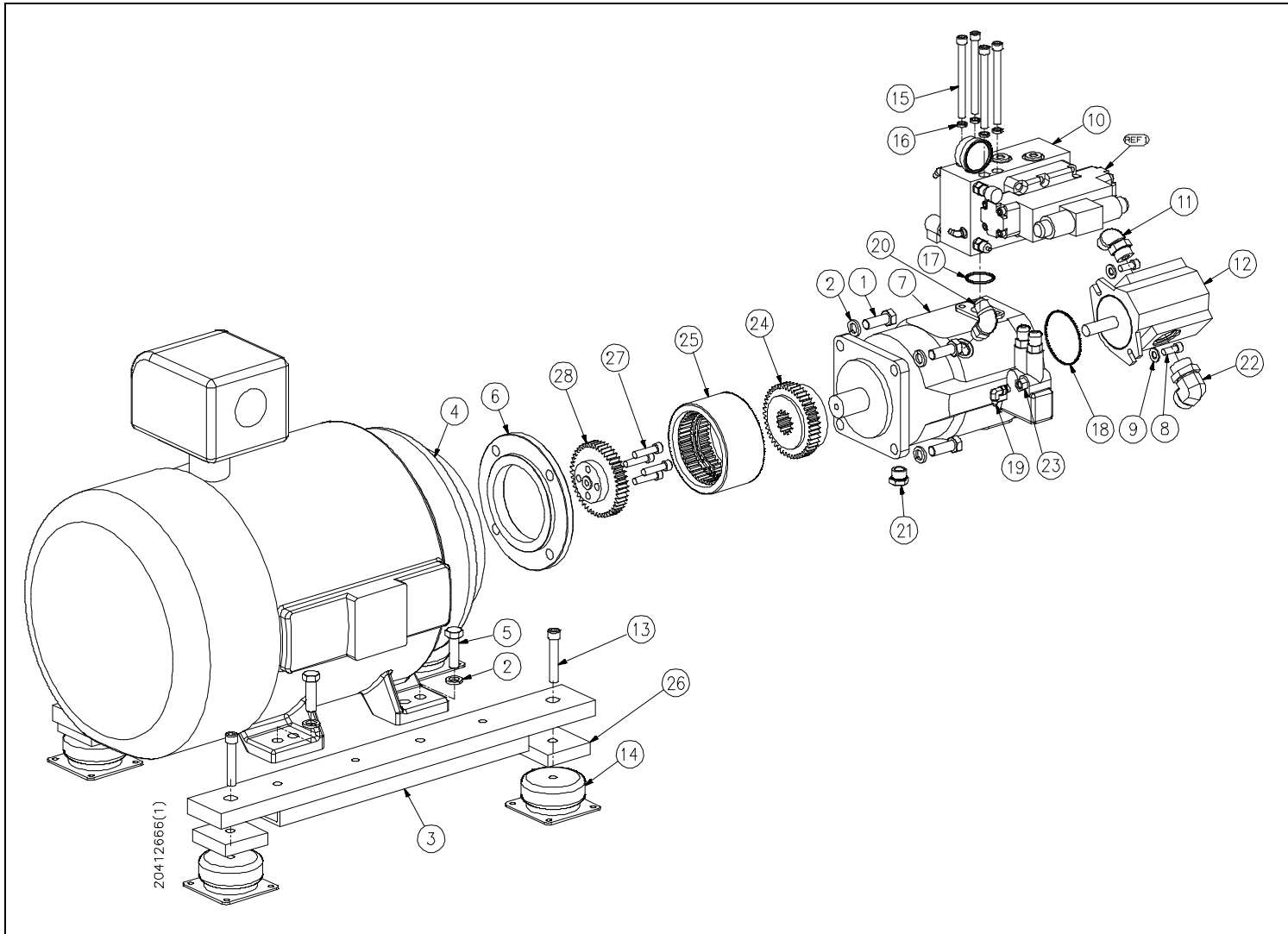



Table 12-11
Hydraulic Manifold Assembly
49835796

Item	Part Number	Description	Quantity
1	05103197	Hydraulic Manifold	1
2	10187417	O-Ring, 1.50 x 1.69 x .09	1
3	05071055	Plug, ORB, .75	3
4	05103189	Check Valve	1
5	10187060	Relief Valve, 25-1500 psi	1
6	10187052	Relief Valve, 25-3000 psi	1
7	05055017	Plug, ORB, .13	2
8	10185585	Solenoid Valve, 24V DC	1
9	05064407	Adapter, JIC/ORB, 1.0 x .75	1
10	10144749	Adapter, JIC/ORB, .25 x .25	1
11	49876089	Adapter, JIC/ORB, .25 x .25	1
12	10142644	Adapter, JIC/ORB, .25 x .25	1
13	49889769	Plug, ORB, .25	1

Figure 12-11: Hydraulic Manifold Assembly

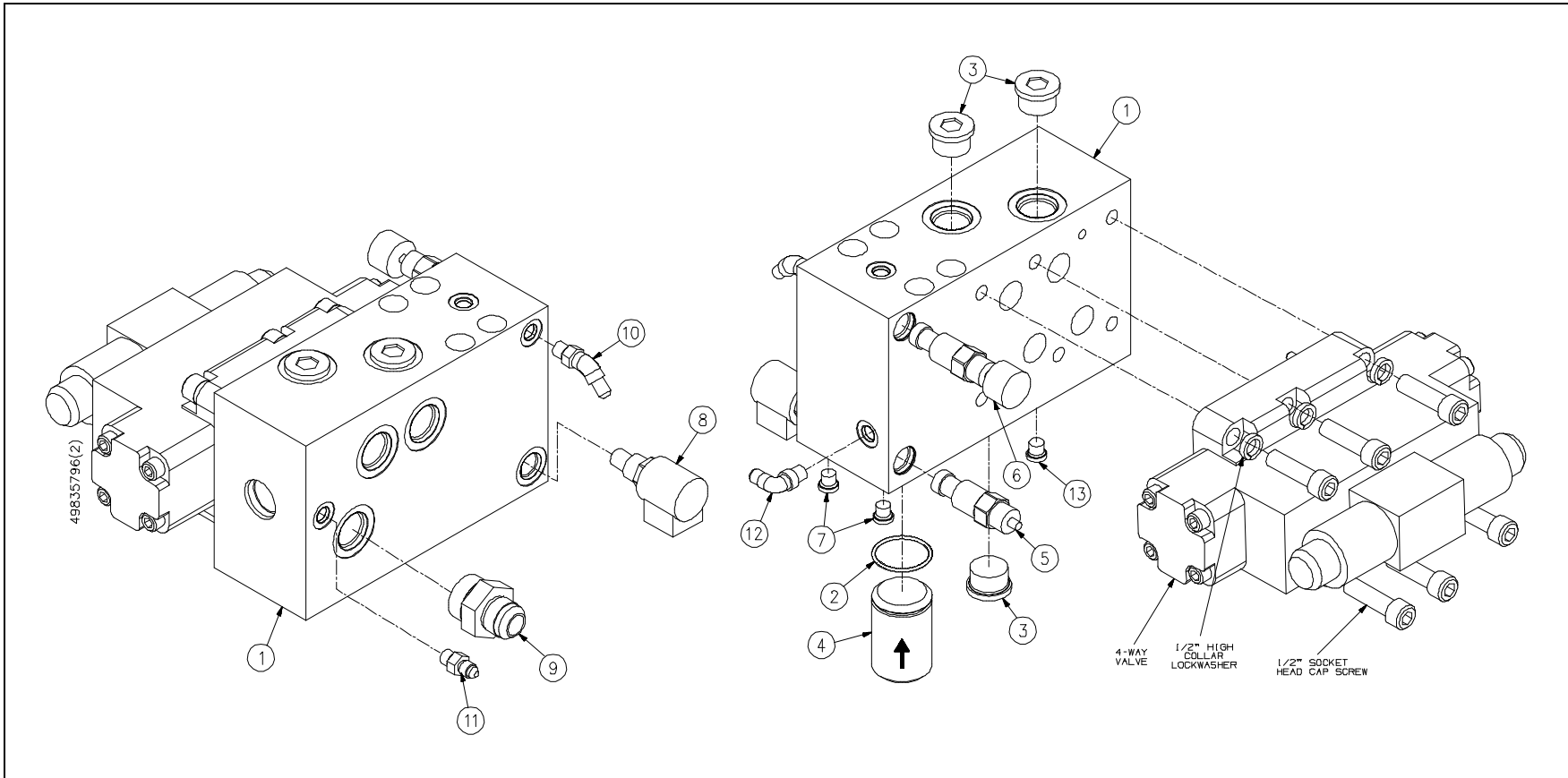



Table 12-12
Hydraulic Hose Connections
05142351

Item	Part Number	Description	Quantity	Item	Part Number	Description	Quantity
1	05106950	Hydraulic Hose Assembly, .75 x 19.0	1	8	05112750	Hydraulic Hose Assembly, .25 x 26.0	1
2	05106968	Hydraulic Hose Assembly, 1.25 x 26.50	1	9	05051214	Hydraulic Hose Assembly, .25 x 39.0	1
3	05106976	Hydraulic Hose Assembly, 1.25 x 24.50	1	10	80079809	Adapter, FSOR/ORB, 1.0 x .75	2
4	20419045	Hose Clamp, 3.0	4	11	80079536	Hydraulic Hose Assembly, 1.0 x 36.0	2
5	10079754	Radiator Hose, 2.50	10.5"	12	80085889	Hydraulic Hose Assembly, .25 x 20.0	1
6	49872245	Split Flange, 2.50	1	13	05061163	Hydraulic Hose Assembly, .75 x 31.0	1
7	05106984	Adapter, Flange/Hose, 2.50 x 2.50	1	14	05049713	Hydraulic Hose Assembly, .75 x 27.0	1

Figure 12-12: Hydraulic Hose Connections

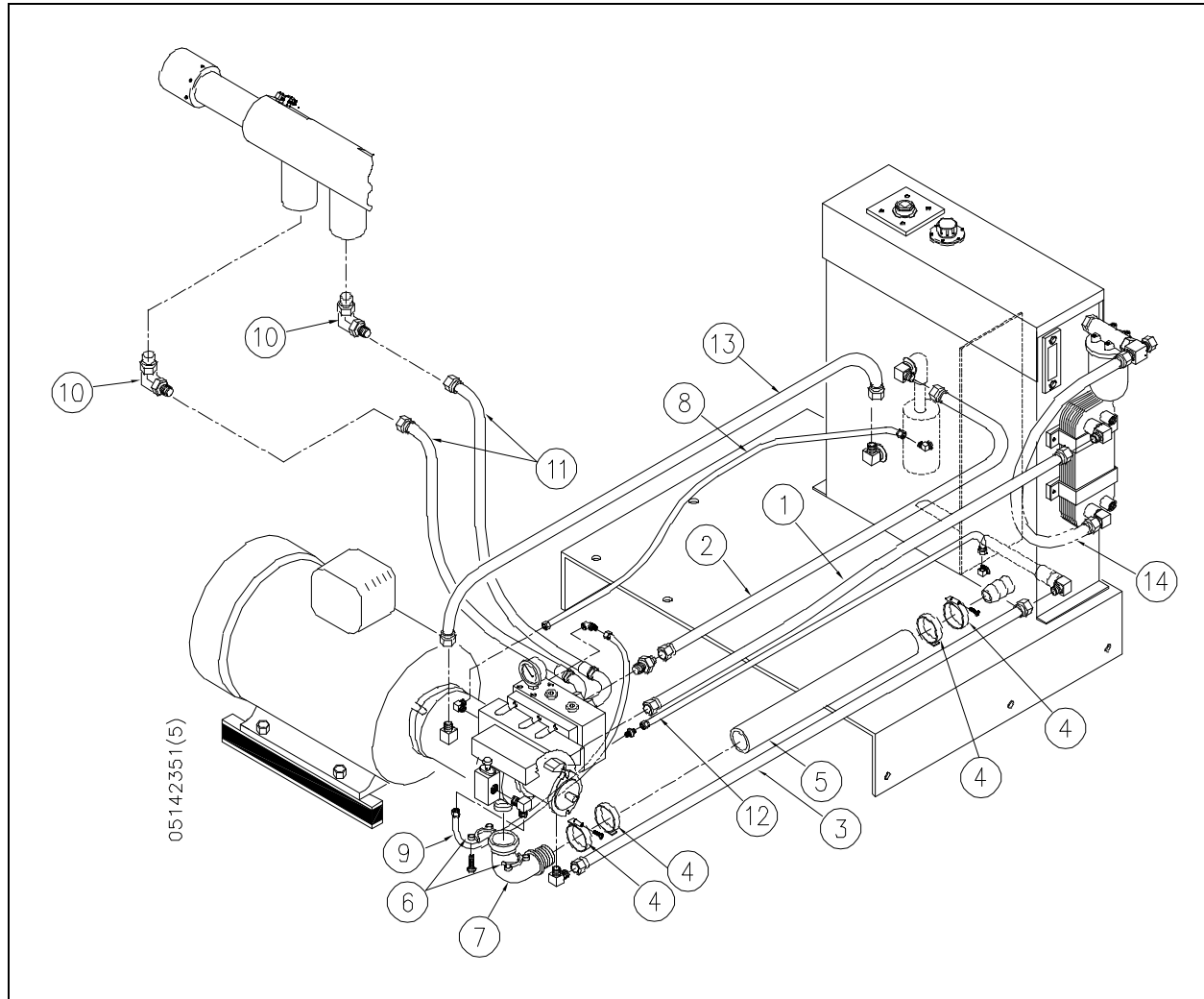



Table 12-13
Reservoir Assembly
05104153

Item	Part Number	Description	Quantity	Item	Part Number	Description	Quantity
1	20444146	Reservoir Weldment	1	15	95829248	Hex Head Screw, 5/16-18 x 1	4
2	05104179	Gasket, Reservoir	1	16	20424011	Adapter, JIC/ORB, 1.25 x 1.25	2
3	05050026	Temperature/Level Switch	1	17	05079967	Gasket, Oil Sensor	1
4	05092739	Air Breather	1	18	10170645	Adapter, ORB/Pipe, 1.0 x .75	1
5	20451474	Level/Temperature Gauge	1	19	05079371	Adapter, BSPP/JIC, .75 x .75	1
6	05103809	Filter Head	1	20	05006291	Diffuser, Return Line	1
7	05104187	Filter Element	1	21	10142644	Adapter, JIC/ORB, .25 x .25	2
8	10151470	Adapter, ORB/JIC, 1.0 x .75	1	22	10080901	Ball Valve	1
9	05069976	Cap, JIC, .75	1	23	10091163	Adapter, JIC/ORB, .75 x .75	2
10	20455107	Tee, JIC/ORB.75 x 1.0	1	24	95033619	Plug, Pipe, .50	1
11	05145941	Heat Exchanger, Water/Oil	1	25	05145966	Bracket, Heat Exchanger	2
12	05060777	Elbow, JIC, .75 x .75	1	26	95738514	Hex Head Screw, 1/2-13 x 1	6
13	95830766	Lock Washer, .31	4	27	10069763	Flat Washer, .50	6
14	10091858	Bulb, Well	1	28	20438668	Lock Washer, .50	6
				29	10082071	Pipe Plug, .38, not shown	1

Figure 12-13: Reservoir Assembly

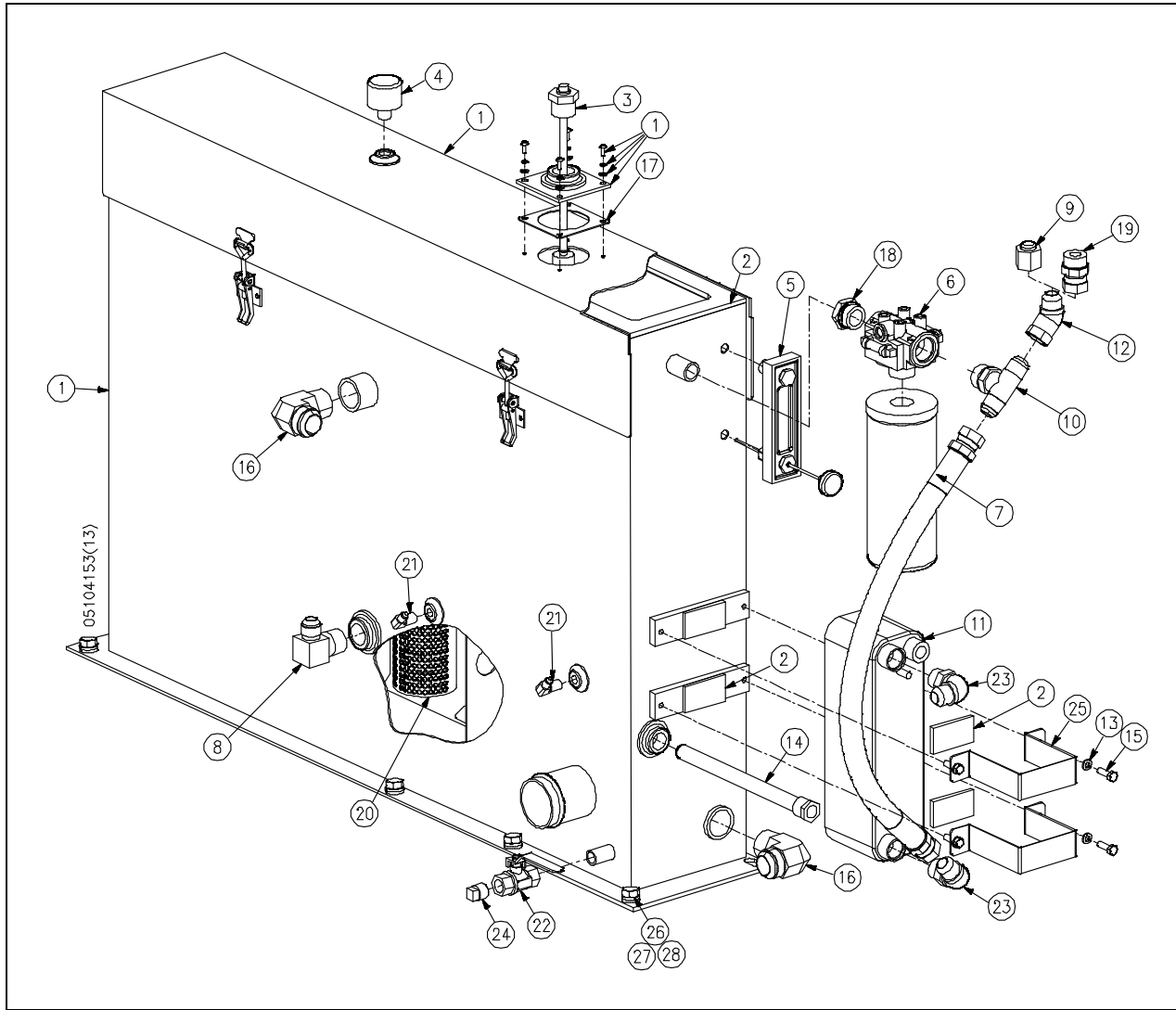



Table 12-14
Bulkhead Pipe Assembly
80079668

Item	Part Number	Description	Quantity	Item	Part Number	Description	Quantity
1	49887011	Adapter, JIC/Pipe, .50 x .50	3	20	49830714	Adapter, Hose/Pipe, .25 x .25	2
2	10091866	Water Modulating Valve	1	21	95157418	Adapter, JIC/Pipe, .50 x .50	1
3	05060207	Pipe Nipple, .50 x 5.0	1	22	49834302	Adapter, Pipe/Tube, .50 x .50	1
4	10100436	Coupling, Pipe, .50 x .50	2	23	10078335	Coupling, Pipe, .25 x .13	1
5	05024815	Solenoid Valve, 24V DC	1	24	95680922	Adapter, JIC/Pipe, .50 x .50	4
6	49886922	Adapter, Bulkhead, .50 x .50	5	25	10189025	Adapter, Hose/JIC, .50 x .50	5
7	20421272	Hose, Push On, .50	230.0"	26	95416319	Hex Head Screw, 3/8-16 x 1	16
8	49888035	Solenoid Valve, 24V DC	1	27	95750394	Lock Washer, .38	16
9	10070092	Jam Nut, 1-14	5	28	49833882	Adapter, Hose/ORB, .50 x .50	1
10	10073823	Tee, .50 x .50	1	29	10077030	Adapter, Tube/Pipe, .25 x .13	2
11	20413789	Manifold, LP Water Inlet	1	30	10079903	Tube, Clear, .25	36.0"
12	80087976	LP Water Filter Assembly	1	31	49834310	Adapter, Pipe/Tube, .50 x .50	1
13	49834328	Adapter, Pipe/Tube, .50 x .25	1	32	05113964	Grommet, 1.75	6
14	10173805	Hose Barb, .50 x .50	5	33	10084523	Pipe Nipple, .50 x 4.0	1
15	10079713	Hose Barb, .50 x .50	2	34	05139506	Pressure Gauge, 0-200 psi	2
16	10077055	Coupling, Bulkhead, .94 x .25	1	35	61126172	Hose, Push-on, .25	72.0"
17	05140751	Pressure Switch, 30 psi	1	36	20412815	Filter, In-Line Strainer	1
18	05111406	Adapter, JIC/Pipe, .50 x .25	2	37	49830722	Adapter, Hose/Pipe, .25 x .25	2
19	10069714	Flat Washer, .38	16	38	95146429	Hex Nut, #8-32	4



Table 12-14
Bulkhead Pipe Assembly
80079668

Item	Part Number	Description	Quantity	Item	Part Number	Description	Quantity
39	49831480	Grommet, Rubber, 3.0	7	41	49868813	Temperature Sensor	1
40	05142062	Pressure Switch, 60 psi	1	42	20453730	Check Valve	1

Figure 12-14: Bulkhead Pipe Assembly

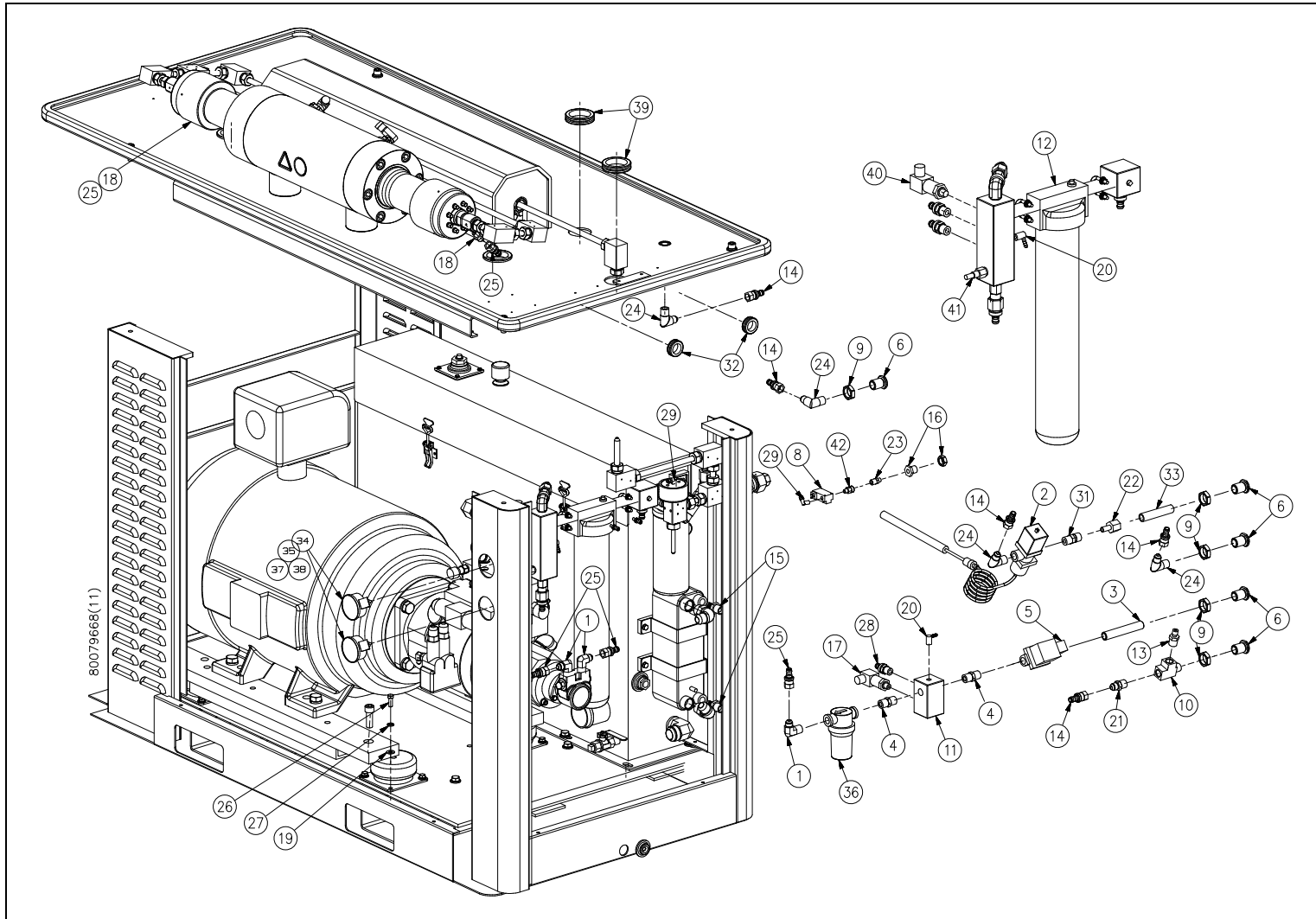



Table 12-15
Cover Assembly
80074768

Item	Part Number	Description	Quantity
1	80074750	Support Assembly	1
2	80074735	Multi-Pin Hinge	1
3	80074727	Cover, Top	2
4	49834708	Cover, Left End	2
5	49834690	Cover, Right End	2
7	49837511	Mounting Bracket	4
8	49837529	Mounting Bracket	4
9	49837503	Spring, Gas	4
10	49837743	Button Head Screw, 3/8-16 x 1.0	32
11	05091988	Flange Nut, 3/8-16	32
12	95897948	Button Head Screw, 10-24 x 1/2	24
13	49832181	Flange Nut, #10-24	24
14	80074719	Gasket, Not Shown	1
15	95670972	Lock Washer, .38	6
16	05091954	Button Head Screw, 3/8-16 x 1.00	6
17	80076748	Cable, Lanyard, 18.75	4
18	49837826	Handle, Pocket Pull, Flush	4

Figure 12-15: Cover Assembly

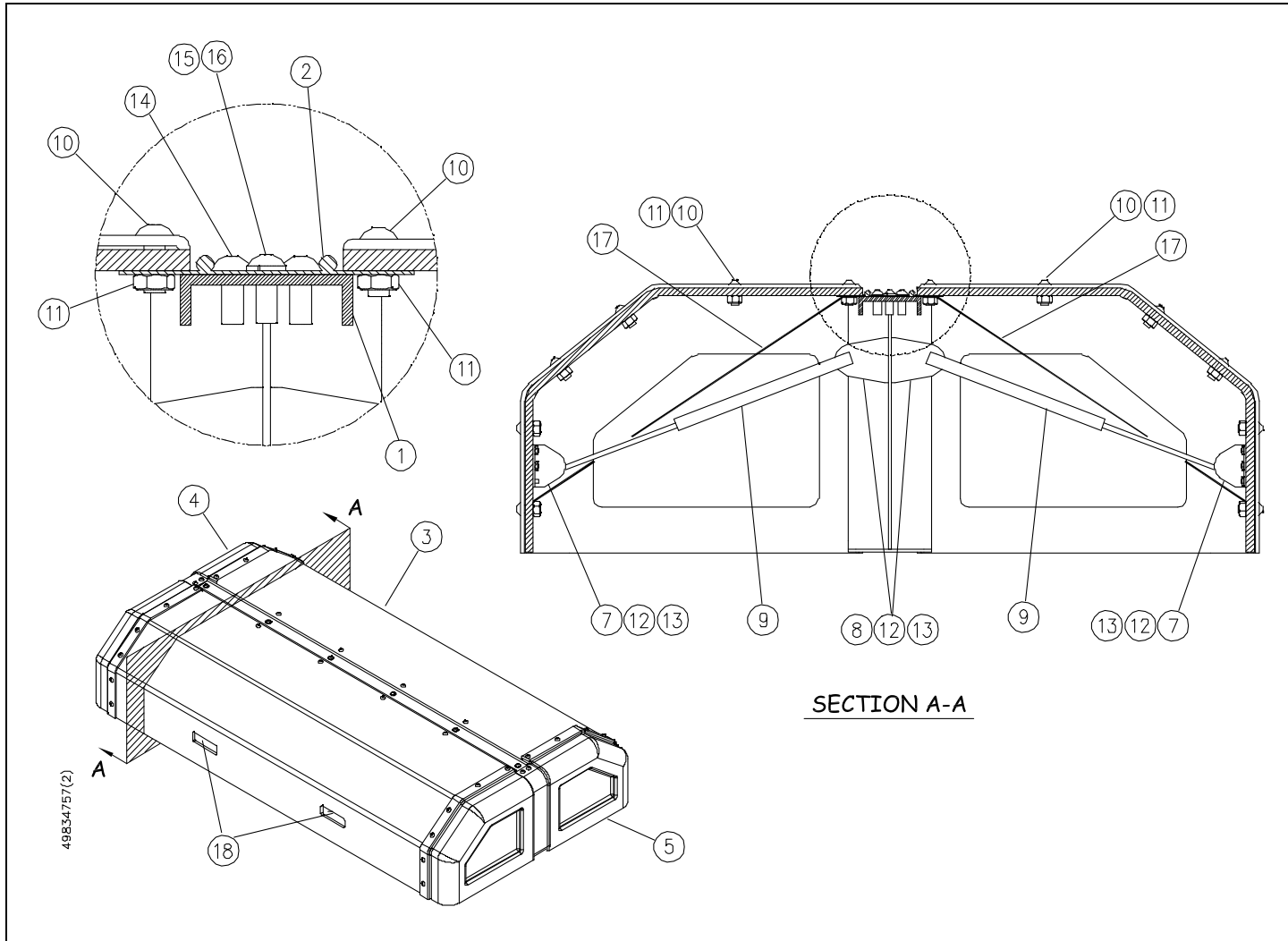
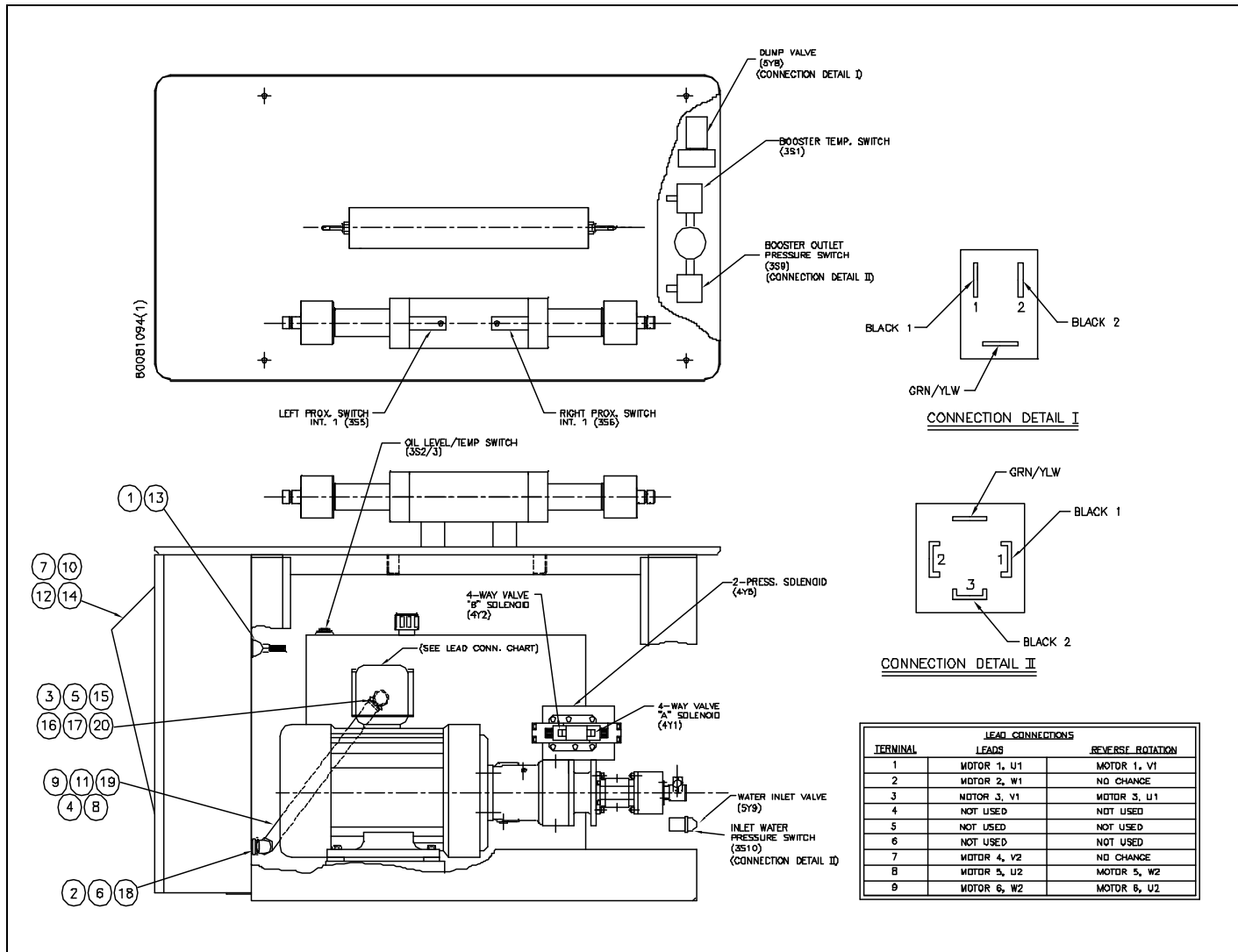



Table 12-16
Electrical Assembly
80077936

Item	Part Number	Description	Quantity	Item	Part Number	Description	Quantity
1	05148531	Harness, Sensor/Solenoid Cable	1	11	05113923	Ring Terminal, #6	1
2	10085520	Flexible Conduit Connector, 1.50	1	12	95716890	Lock Washer, .50	4
3	80080344	Terminal Lug, #10-250	9	13	10125912	Cable Tie, .87	5
4	10086700	Flexible Conduit, 1.50	42.0"	14		Starter/Control Panel Configuration	1
5	10115830	Flexible Conduit Connector, 1.50	1	15	05107339	Conduit Bushing, 2.50 x 1.50	1
6	05081377	Conduit Bushing, 1.50 x 1.50	1	16	05107347	Conduit Locknut, 2.50	1
7	10069763	Flat Washer, .50	4	17	----	Not used on this assembly	--
8	10105674	Wire, #4, Black	504.0"	18	10085405	Gasket Assembly, Flexible Conduit, 1.50	1
9	49886583	Wire, #6, Green	84.0"	19	05149778	Connector, Crimp Pin, #4	12
10	95423695	Hex Nut, 1/2-13	4	20	05141692	Connector, Crimp Ferrule, #8	12

Figure 12-16: Electrical Assembly



LEAD CONNECTIONS		
TERMINAL	LEADS	REVERSE ROTATION
1	MOTOR 1, U1	MOTOR 1, V1
2	MOTOR 2, W1	NO CHANGE
3	MOTOR 3, V1	MOTOR 3, U1
4	NOT USED	NOT USED
5	NOT USED	NOT USED
6	NOT USED	NOT USED
7	MOTOR 4, V2	NO CHANGE
8	MOTOR 5, U2	MOTOR 5, W2
9	MOTOR 6, W2	MOTOR 6, U2



Table 12-17
Controls Subassembly
80077845

Item	Part Number	Description	Quantity	Item	Part Number	Description	Quantity
1	10176410	Wire, #16, Blue	3000.0"	19	20416825	Illuminated Operator	2
2	10170165	Wire, #16/1 MM 2, Green/Yellow	190.0"	20	05140637	Contact Block	1
3	05032420	Terminal Block, #24-#12	5	21	10149094	Pilot Light, Green	1
4	10103034	DIN Mounting Rail	36.0"	22	05113634	Terminal Block, 3 Level	18
5	10157667	Pan Head Screw, 10-32 x 3/4	12	23	05112826	Terminal Block Jumper	1.7
6	49839335	Circuit Breaker	1	24	49830268	Cable, LRP Channel 1 To 550	1
7	20416802	Emergency Stop Switch	1	25	20497660	Lamp Block	2
8	20419143	Contact Block	3	26	05140629	Legend Plate Holder, Black	1
9	05049473	Legend Plate	1	27	05140579	Mounting Adapter, Contact Block	1
10	05032438	Terminal Block, #22-#14	28	28	20414500	Subplate, Electrical Enclosure	1
11	05032362	End Anchor, Terminal Block	4	29	10156859	I/O Rack, 4 Slot	1
12	05032370	End Barrier	1	30	10146363	Single Point Output Module	4
13	05032388	Center Jumper, Terminal Block	1	31	10157659	Lock Washer, .25	2
14	05032396	Terminal Block Marker	0.7	32	05021944	Wiring Duct	1.2
15	05032412	Blank Markers, Terminal Blocks	0.4	33	10170132	Push Rivet	28
16	10186104	Tube Base Relay	1	34	49874191	Hole Seal, .50	10
17	10196012	Relay Base, 11 Pin	1	35	05140926	Wire, #16, Orange	192.0"
18	10170504	Push Button Switch, Illuminated	1	36	10185395	Connector, Crimp Ferrule, #16	200



Table 12-17
Controls Subassembly
80077845

Item	Part Number	Description	Quantity	Item	Part Number	Description	Quantity
37	---	Not used on this assembly	--	51	05140157	Panelview Display, 550	1
38	20463222	Electrical Enclosure	1	52	05115134	End Barrier, 3 Level Terminal Block	1
39	---	Not used on this assembly	--	53	49833411	Selector Switch, Keyed, 2 Position	1
40	10170157	Wire, #10/4 MM 2, Green/Yellow	36.0"	54	05114889	Legend Plate, Remote Control On/Off	1
41	10094712	Ring Terminal, 14-10, 1/4	3	55	05117601	End Barrier, 3 Level Terminal Block	1
42	95416335	Hex Nut, 1/4-20	4	59	05115704	Terminal Block, #16-#6	1
43	10149086	Pilot Light, Red	1	60	05144308	Programmable Controller	1
44	---	Not used on this assembly	--	61	49874233	Hole Seal, 1.50, Conduit Hole	2
45	10102242	Spiral Wrap, .38	12.0"	62	49874225	Hole Seal, 2.0, Conduit Hole	1
46	20436867	Disconnect Plug	18	65	---	Not used on this assembly	--
48	---	Not used on this assembly	--	66	---	Not used on this assembly	--
49	05144316	Base Controller, 1500, 24V	1				
50	---	Not used on this assembly	--				

Figure 12-17: Controls Subassembly

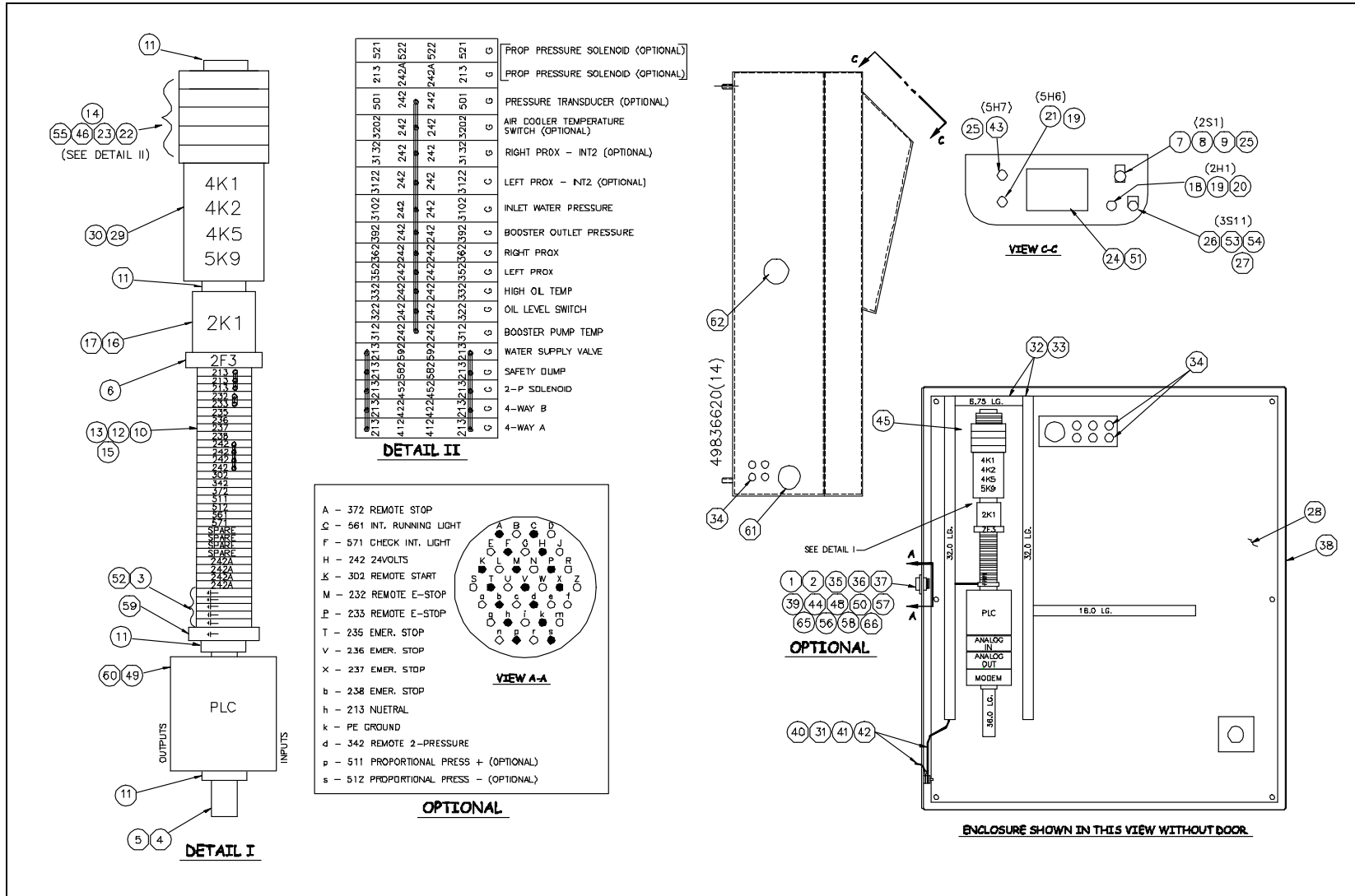



**Table 12-18
Control Panel Configuration
Wye-Delta
80077944**

Item	Part Number	Description	Quantity	Item	Part Number	Description	Quantity
1	80078025	Circuit Breaker, 100A, 600V	1	19	05106398	Wire, #3, Green/Yellow	24.0"
2	05081955	Socket Head Screw, 8-32 x 2	4	20	10170157	Wire, #10/4 MM 2, Green/Yellow	42.0"
3	80077993	Rotary Drive, Circuit Breaker	1	21	05019898	Wire, #14, Black	90.0"
4	80078009	Shaft Extension, Circuit Breaker	1	22	05019617	Connector, Crimp Ferrule, #14	12
5	80078090	Operator Handle, Circuit Breaker	1	23	05140686	Circuit Breaker, 600V	1
6	80078017	Terminal Cover, Breaker	2	24	05032362	End Anchor, Terminal Block	7
7	10105674	Wire, #4, Black	144.0"	25	05140876	Power Supply, 24V DC	1
8	05149778	Crimp Pin Connector, #4	6	26		Controls Subassembly	1
9	49836984	Contactactor, Non-Reversing	2	27	49833429	Timing Relay	1
10	10157667	Pan Head Screw, 10-32 x 3/4	8	28	10185395	Connector, Crimp Ferrule, #16	8
11	10103034	DIN Mounting Rail	29.0"	29	10176410	Wire, #16, Blue	48.0"
12	05111448	Overload Relay, 26-85A	1	30	10170165	Wire, #16/1 MM 2, Green/Yellow	48.0"
13	49833452	Auxiliary Contact	2	31	49836562	Control Transformer	1
14	49833460	Interlock Contactactor	1	32	80074131	Circuit Breaker, 2A	1
15	80077902	Contactactor, Non-Reversing	1	33	10098226	Tube Base Relay	1
16	49830607	Y-Delta Wiring Kit, 72A	1	34	10098242	Screw Terminal, Tube Base Socket	1
17	05095609	Ground Lug, -#6-#350	2	35	10181550	Wire, #16, Red	100.0"
18	95423620	Hex Head Screw, 5/16-18 x 3/4	2				

Figure 12-18: Control Panel Configuration – Wye-Delta

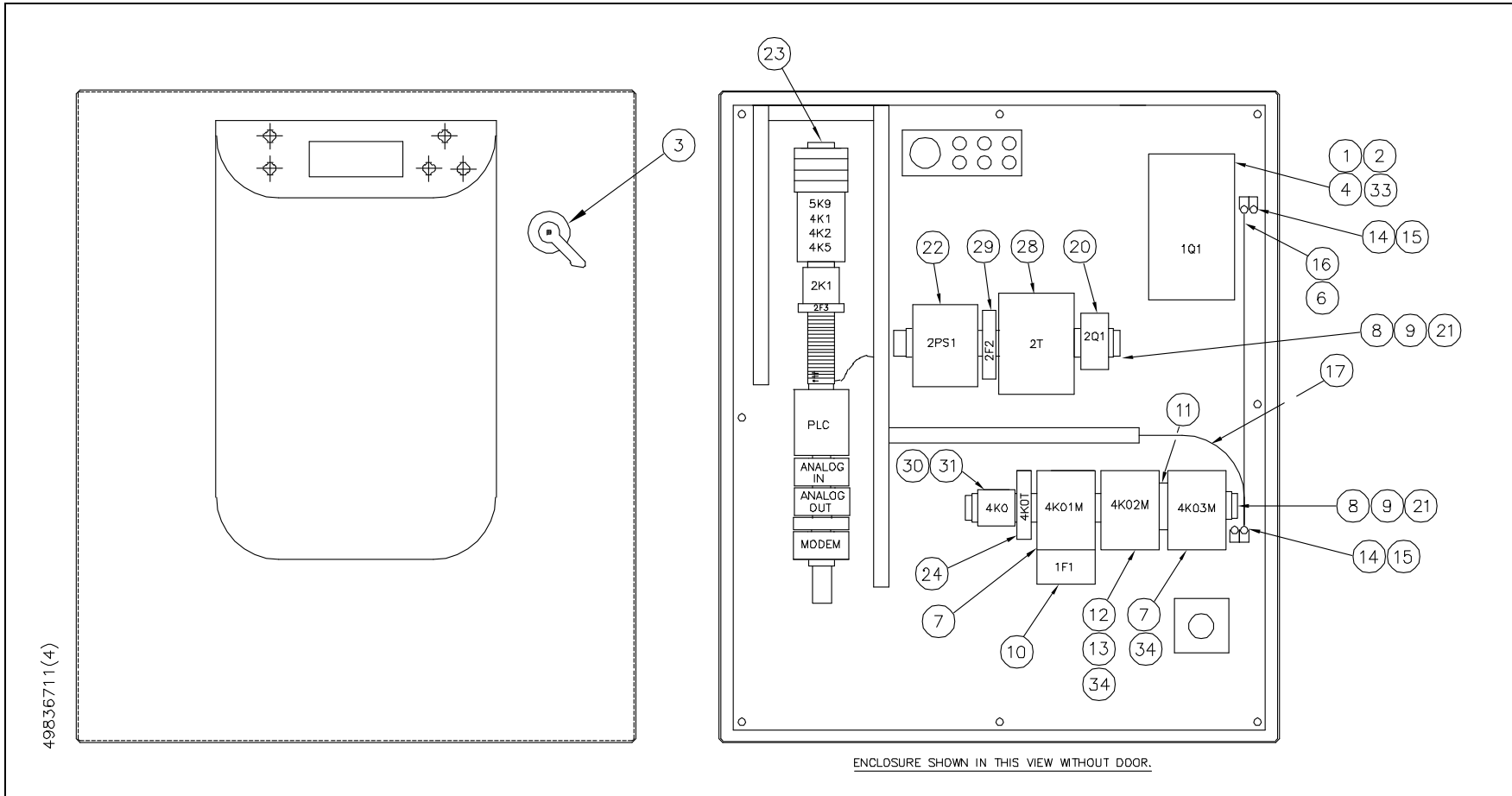



Table 12-19
Control Panel Configuration
Softstart
20471164

Item	Part Number	Description	Quantity	Item	Part Number	Description	Quantity
1	80078025	Circuit Breaker, 100A, 600V	1	17	05140876	Power Supply, 24V DC	1
2	05081955	Socket Head Screw, 8-32 x 2	4	18	05140686	Circuit Breaker, 600V	1
3	80077993	Rotary Drive, Circuit Breaker	1	19	05032362	End Anchor, Terminal Block	7
4	80078009	Shaft Extension, Circuit Breaker	1	20	10170157	Wire, #10/4 MM 2, Green/Yellow	42.0"
5	80078090	Operator Handle, Circuit Breaker	1	21		Controls Subassembly	1
6	80078017	Terminal Cover, Breaker	2	22	10185395	Connector, Crimp Ferrule, #16	8
7	20452887	Weld Cable	72.0"	23	10176410	Wire, #16, Blue	48.0"
8	20453331	Crimp Ferrule Pin Connector, #2	20	24	10170165	Wire, #16/1 MM 2, Green/Yellow	48.0"
9	20471160	Contactora, Softstart	1	25	49836562	Control Transformer	1
10	10157667	Pan Head Screw, 10-32 x 3/4	8	26	80074131	Circuit Breaker, 2A	1
11	10103034	DIN Mounting Rail	25.0"	27	10098226	Tube Base Relay	1
12	05095609	Ground Lug, -#6-#350	2	28	10098242	Screw Terminal, Tube Base Socket	1
13	95423620	Hex Head Screw, 5/16-18 x 3/4	2	29	10181550	Wire, #16, Red	100.0"
14	10170140	Wire, #6, Green/Yellow	24.0"	30	20435759	Protective Module	1
15	05019898	Wire, #14, Black	90.0"	31	20435751	Softstart Filter	2
16	05019617	Connector, Crimp Ferrule, #14	12				

Figure 12-19: Control Panel Configuration – Softstart

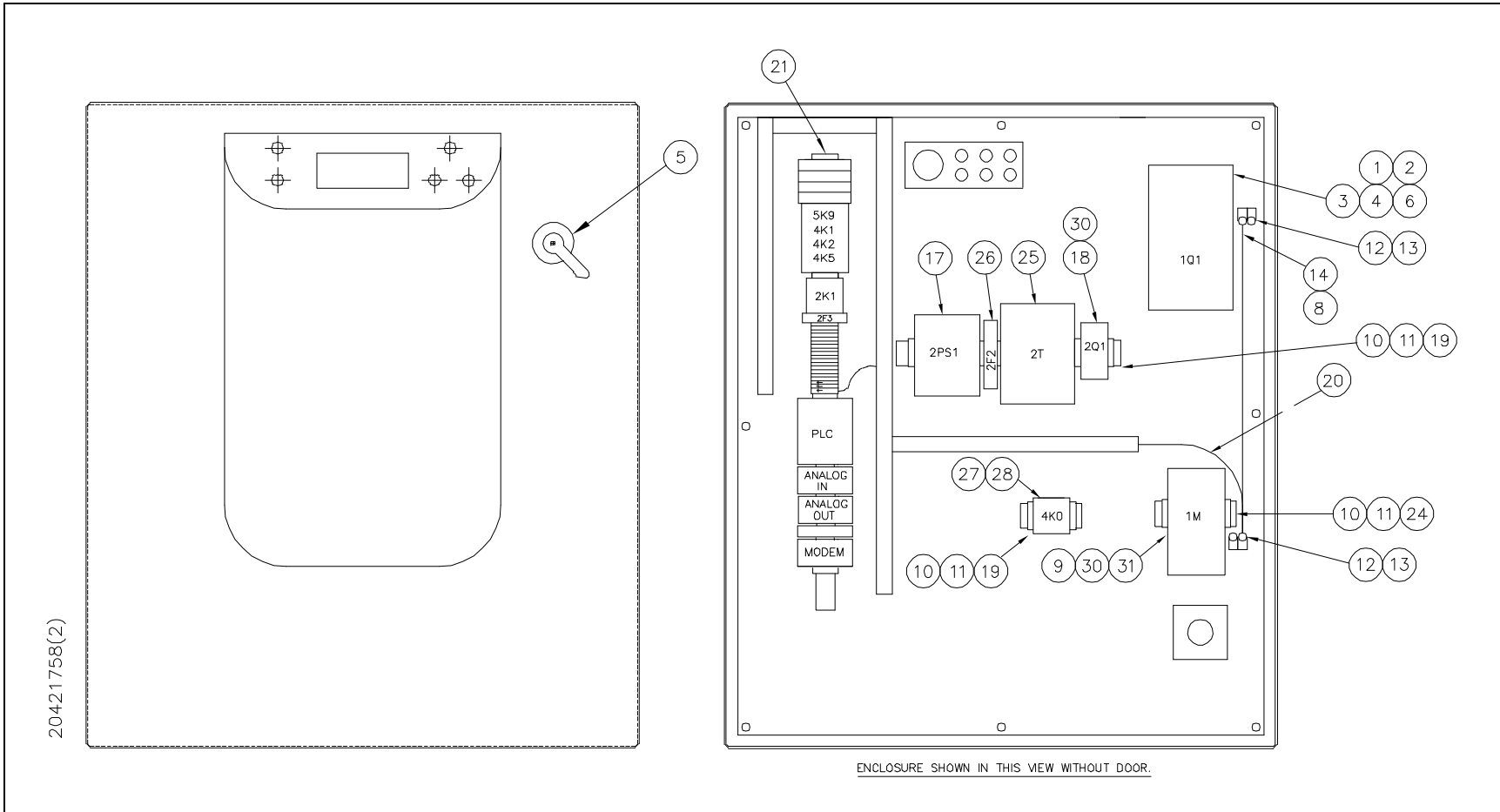



Table 12-20
Proportional Pressure Control
80075732

Item	Part Number	Description	Quantity
1	80071087	Hydraulic Solenoid Valve, 24V, Cartridge	1
2	49867104	Cable, #18, 4 Conductor	96.0"
3	10067205	Cable Connector, .50	1
4	10176410	Wire, #16, Blue	100.0"
5	10185395	Connector, Crimp Ferrule, #16	10



Table 12-21
High Pressure Transducer
20431959

Item	Part Number	Description	Quantity
1	10069326	HP Tube, .56 x 4.0	1
2	10079465	Tee, HP, .56	1
3	20412627	HP Tube, .56 x 11.50	1
4	10079580	Bushing, HP, .56 x .25	1
5	05071782	HP Tube, Bent, .25	1
6	49838478	Pressure Transducer, 0-75,000 psi	1
7	10067205	Cable Connector, .50	1
8	10176410	Wire, #16, Blue	100.0"
9	10185395	Connector, Crimp Ferrule, #16	10
10	10078459	HP Gland, .25	1
11	10078426	HP Collar, .25	1
12	05086905	Flexible Conduit, .63	12.0"
13	05131347	Ferrule, .50	2

Figure 12-21: High Pressure Transducer

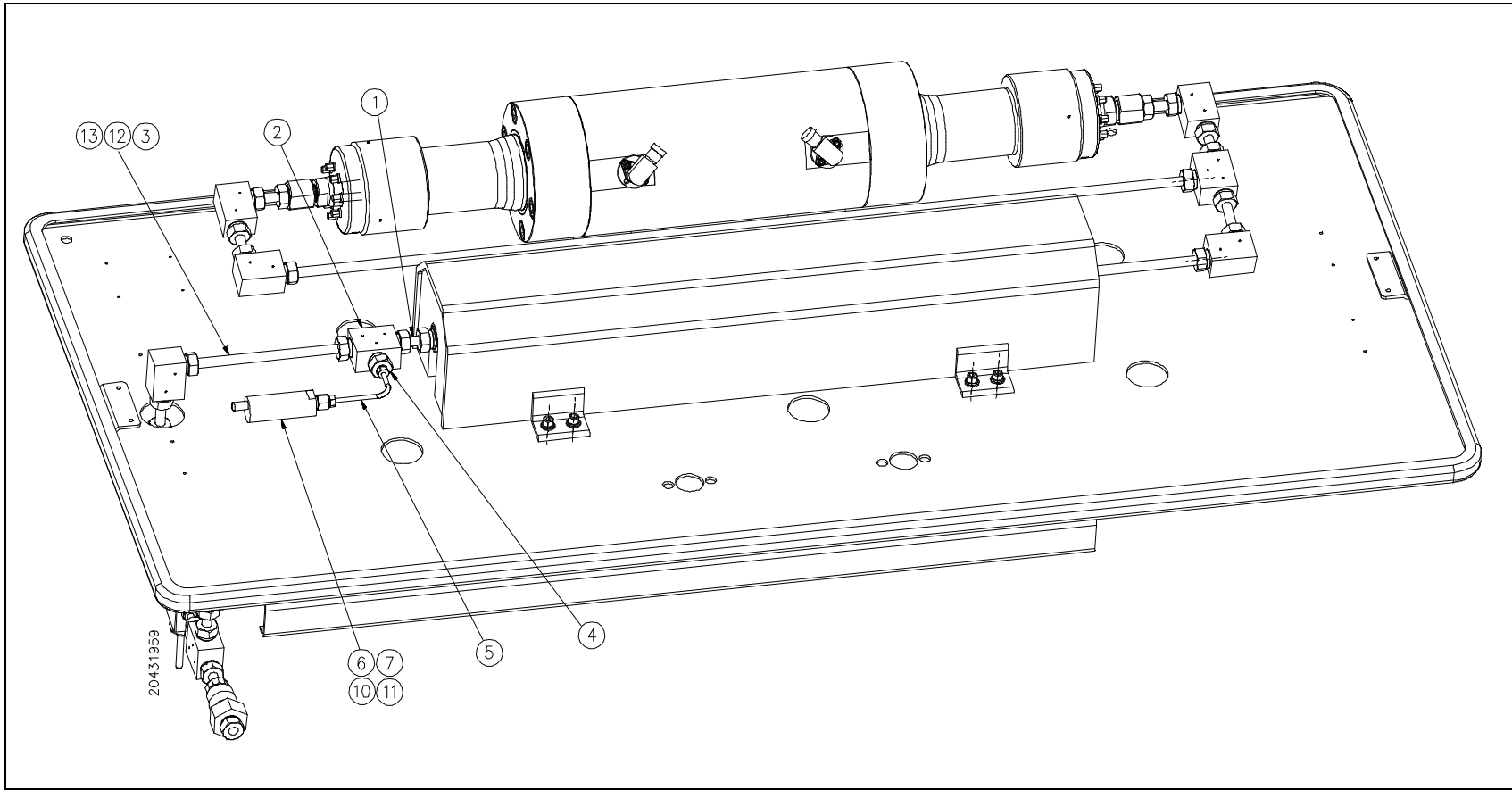



Table 12-22
Redundant Kit
20431316

Item	Part Number	Description	Quantity	Item	Part Number	Description	Quantity
1	72122493	Intensifier Topworks, HSEC	1	16	05112057	HP Tube, .56 x 4.97	2
2	05111406	Adapter, JIC/Pipe, .50 x .25	2	17	10078525	Elbow, HP, .56 x .56	3
3	80079536	Hydraulic Hose Assembly, 1.0 x 36.0	2	18	10079465	Tee, HP, .56	2
4	80079684	Adapter, FSOR/ORB, 1.0 x .75	5	19	10079275	2-Way Valve	2
5	80079817	Adapter, FSOR/ORB, 1.0 x 1.0	4	20	10078608	HP Gland, .56	2
6	80079551	Ball Valve, 2-Way	4	21	10079119	HP Collar, .56	2
7	80079692	Adapter, FSOR/ORB, 1.0 x 1.0	4	22	05086905	Conduit, .63	60.0"
8	20417552	Connector Plug W/Bead	2	23	05131347	Ferrule, .50 Hose	2
9	10067205	Connector Cable, .50	2	24	95413696	Lock Washer, .50	4
10	10083012	Lock Nut, .50	2	25	95383790	Socket Head Screw, 1/2-13 x 1	4
11	10082857	Gasket Assembly	2	27	20417180	SST Tubing	2
12	05145271	HP Tube, .56 x 55.19	1	28	05074661	HP Tube, .56 x 4.59	1
13	10069326	HP Tube, .56 x 4.0	5	29	20413856	Pipe Nipple, .75 x 9.0	1
14	05145297	HP Tube, .56 x 4.18	1	30	20451641	Latch Pin	4
15	80079809	Adapter, FSOR/ORB, 1.0 x .75	1	31	20421272	Hose, Push-On, .50	110.0"
				32	49898729	Flat Washer, M12	4

Figure 12-22: Redundant Kit

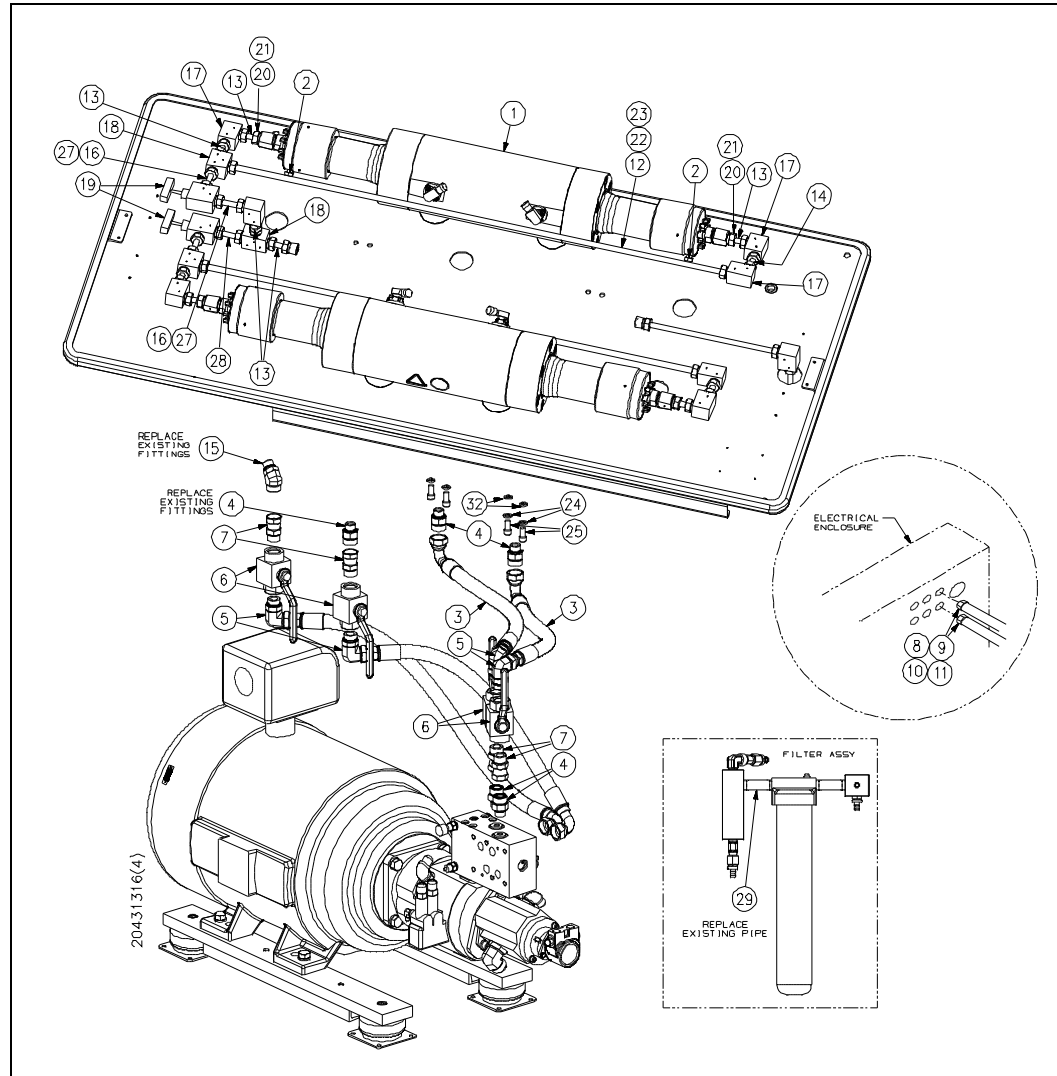
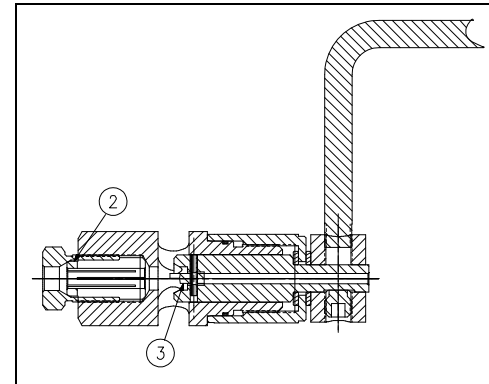

Table 12-23
High Pressure Coning Tools

Item	Part Number	Description
	05108832	Hand Coning Tool Assembly, .25
	05108857	Hand Coning Tool Assembly, .38
	05108840	Hand Coning Tool Assembly, .56
	05109897	Power Coning Tool Assembly, .25
	05109889	Power Coning Tool Assembly, .38
	05109871	Power Coning Tool Assembly, .56
1	05108808	Blade, .25
	05108824	Blade, .38
	05108816	Blade, .56
2	05108972	Collet, .25
	05108964	Collet, .38
	20439964	Collet, .56
3	05109814	Retainer, .25
	05109822	Retainer,.38
	05109830	Retainer, .56
	05120472	Cone and Thread Lubricant, 4 oz.

Figure 12-23: High Pressure Coning Tools

Hand Coning Tool Assembly



Power Coning Tool Assembly

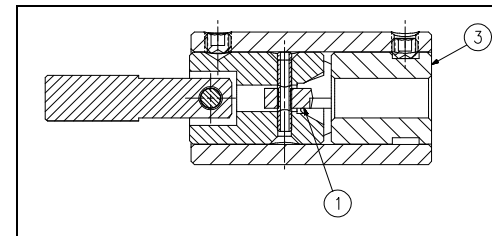
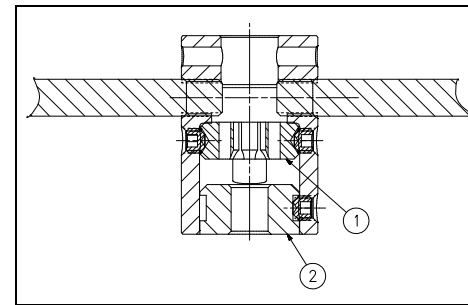

Table 12-24
High Pressure Threading Tools

Item	Part Number	Description
	05108865	Hand Threading Tool Assembly, .25
	05108873	Hand Threading Tool Assembly, .38
	05108881	Hand Threading Tool Assembly, .56
	05122742	Power Threading Tool Assembly, .25
	05120258	Power Threading Tool Assembly, .38
	05122759	Power Threading Tool Assembly .56
1	05108899	1/4-20 Threading Die
	05108915	3/8-16 Threading Die
	10078301	9/16-18 Threading Die
2	05108741	Retainer, .25
	05108758	Retainer, .38
	05108766	Retainer, .56
	05108782	Tube Vise, .25
	05108790	Tube Vise, .38
	05108774	Tube Vise, .56
	20437825	Tube Vise, .75
	20440071	Tube Vise, 1.0

Figure 12-24: High Pressure Threading Tools

Hand Threading Tool Assembly



Power Threading Tool Assembly

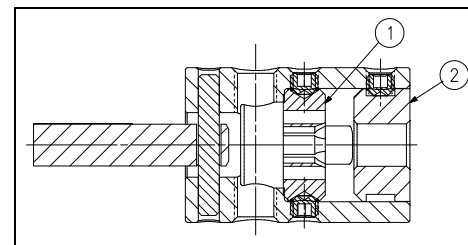
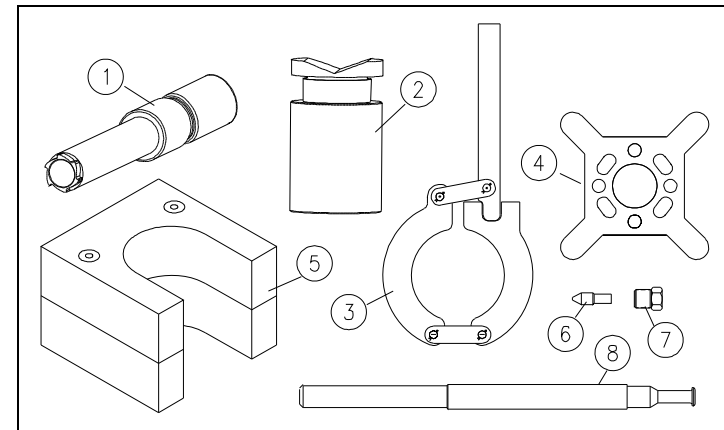

Table 12-25
Maintenance Tools and Lubricants

Item	Part Number	Description
1	20477460	Plunger Removal Tool, .88 Plunger
	20477469	Plunger Removal Tool, 1.13 Plunger
2	20484961	Vee Block Cradle
3	05066139	Cylinder Wrench
4	80079239	End Cap Wrench, HSEC, 6x/8x
5	80078330	HP Seal Removal Tool Stand
6	10079523	HP Plug, .38
	10078772	HP Plug, .56
7	10078129	HP Gland, .38
	10078608	HP Gland, .56
8	10148674	HP Seal Installation Tool, .88 Plunger
	05146618	HP Seal Installation Tool, 1.13 Plunger

Figure 12-25: Maintenance Tools and Lubricants

Maintenance Tools



**Table 12-25
Maintenance Tools and Lubricants**

Item	Part Number	Description
	20470475	Seal Tool Kit, Pneumatic Control Valves
1	20470417	Seal Installation Tool
2	05067350	Seal Positioning Tool, NO/NC Valves, 2-Port Dump Valve
3	49833114	Seal Positioning Tool, Quick Release Valve, 3-Port Dump Valve
4	20470413	Seal Push Tool
		Lubricants
	10084440	Pure Goop Thread Lubricant, 1.0 oz.
	10087385	FML-2 Grease, 14.5 oz.
	49832199	JL-M Thread Lubricant, 16 oz.
	80082191	JL-M Thread Lubricant, 15 ML
	20487868	Threadlocker Adhesive
	20494983	Threadlocker Primer
	10184802	Optimol, Anti-Seize Grease

Seal Tool Kit, Pneumatic Control Valves

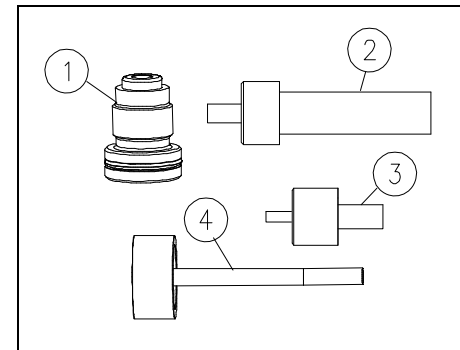

Table 12-26
Focusing Tubes

Part Number	Description
05147889	R-100 0.018" (0.457 mm) x 2.00" (50.8 mm)
10139426	R-100 0.021" (0.533 mm) x 2.00" (50.8 mm)
20451227	R-100 0.021" (0.533 mm) x 3.13" (79.4 mm)
20452309	R-100 0.025" (0.635 mm) x 3.13" (79.4 mm)
10126969	R-100 0.030" (0.762 mm) x 3.13" (79.4 mm)
20428126	R-100 0.030" (0.762 mm) x 4.0" (101.6 mm)
20452161	R-100 0.030" (0.762 mm) x 6.0" (152.4 mm)
80075252	R-100 0.036" (0.914 mm) x 3.13" (79.4 mm)
49833593	R-100 0.039" (0.991 mm) x 3.13" (79.4 mm)
49835390	R-100 0.040" (1.016 mm) x 3.13" (79.4 mm)
20432695	R-100 0.043" (1.092 mm) x 2.0" (50.8 mm)
10126928	R-100 0.043" (1.092 mm) x 3.13" (79.4 mm)
20452135	R-100 0.043" (1.092 mm) x 4.0" (101.6 mm)
20452153	R-100 0.043" (1.092 mm) x 6.0" (152.4 mm)
10186799	R-100 0.050" (1.321 mm) x 3.13" (79.4 mm)
05117528	R-100 0.052" (1.321 mm) x 3.13" (79.4 mm)
05051891	R-100 0.058" (1.473 mm) x 3.13" (79.4 mm)
10126936	R-100 0.063" (1.600 mm) x 3.13" (79.4 mm)
10139418	R-100 0.093" (2.632 mm) x 3.13" (79.4 mm)

Figure 12-26: Focusing Tubes
R-100 Focusing Tubes

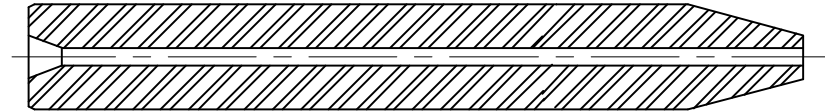

Table 12-26
Focusing Tubes

Part Number	Description		
05097928	R-500	0.021" (0.533 mm) x 2.00" (50.8 mm)	<p style="text-align: center;">R-500 Focusing Tubes</p> 
05105366	R-500	0.043" (1.092 mm) x 2.75" (69.9 mm)	
05097944	R-500	0.030" (0.762 mm) x 3.13" (79.4 mm)	
05116652	R-500	0.036" (0.914 mm) x 3.13" (79.4 mm)	
05097936	R-500	0.043" (1.092 mm) x 3.13" (79.4 mm)	
05130919	R-500	0.063" (1.600 mm) x 3.13" (79.4 mm)	
05130927	R-500	0.093" (2.632 mm) x 3.13" (79.4 mm)	

Table 12-27
Standard Sapphire Orifice

Part Number	Description	Part Number	Description	Part Number	Description
A2260001	0.001" (0.025 mm)	A2260009	0.009" (0.229 mm)	A2260018	0.018" (0.457 mm)
A2260002	0.002" (0.051 mm)	A2260010	0.010" (0.254 mm)	A2260019	0.019" (0.483 mm)
A2260003	0.003" (0.076 mm)	A2260011	0.011" (0.279 mm)	A2260020	0.020" (0.508 mm)
A2260004	0.004" (0.102 mm)	A2260012	0.012" (0.305 mm)	A2260021	0.021" (0.533 mm)
A2260005	0.005" (0.127 mm)	A2260013	0.013" (0.330 mm)	A2260022	0.022" (0.559 mm)
A2260006	0.006" (0.152 mm)	A2260014	0.014" (0.356 mm)	A2260024	0.024" (0.610 mm)
A2260007	0.007" (0.178 mm)	A2260015	0.015" (0.381 mm)	A2260028	0.028" (0.711 mm)
A2260008	0.008" (0.203 mm)	A2260016	0.016" (0.406 mm)	A2260032	0.032" (0.813 mm)

Figure 12-27: Standard Sapphire Orifice

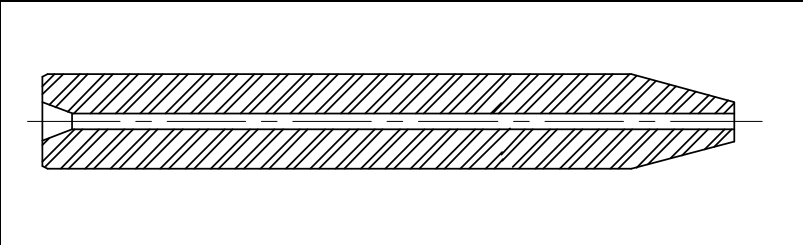
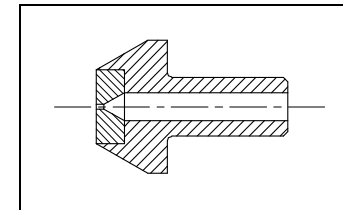

Table 12-28
Standard Diamond Orifice

Part Number	Description	Part Number	Description	Part Number	Description
49888852	0.003" (0.076 mm)	49888910	0.009" (0.229 mm)	49888969	0.016" (0.406 mm)
49888860	0.004" (0.102 mm)	49888928	0.010" (0.254 mm)	49888977	0.018" (0.457 mm)
49888878	0.005" (0.127 mm)	49888936	0.012" (0.305 mm)	20436198	0.019" (0.483 mm)
49888886	0.006" (0.152 mm)	49836786	0.013" (0.330 mm)	49888985	0.020" (0.508 mm)
49888894	0.007" (0.178 mm)	49888944	0.014" (0.356 mm)	49888993	0.022" (0.559 mm)
49888902	0.008" (0.203 mm)	49888951	0.015" (0.381 mm)		

Figure 12-28: Standard Diamond Orifice

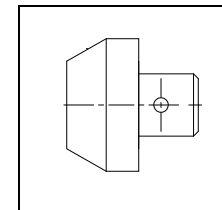
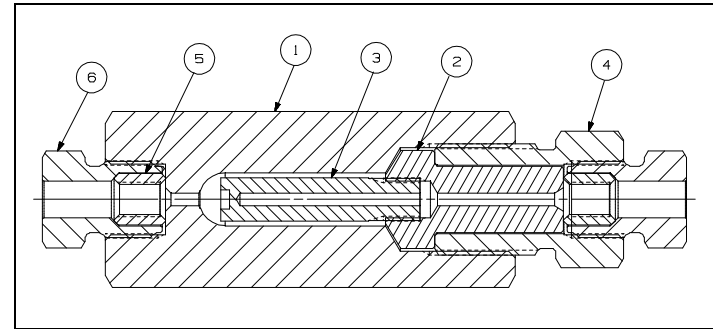

Table 12-29
High Pressure Water Filter Assemblies

Item	Part Number	Description	Quantity
	05114137	Inline Water Filter, .25	
1	05114129	Filter Body	1
2	05114152	Retainer, Filter Element	1
3	05110531	Filter Element	1
4	05114145	Adapter Gland	1
5	10078426	HP Collar	2
6	10078459	HP Gland	2
	CJ200988	Inline Water Filter, .38	
1	10078715	HP Collar	2
2	10078129	HP Gland	2
3	CJ300988	Filter Body	1
4	CJ400988	Adapter Gland	1
5	SKJA266	Filter Element	1
6	SKJA286	Retainer, Filter Element	1
7	SKJA287	Bayonet Nipple	1

Figure 12-29: High Pressure Water Filter Assemblies

HP Inline Water Filter, .25



HP Inline Water Filter, .38

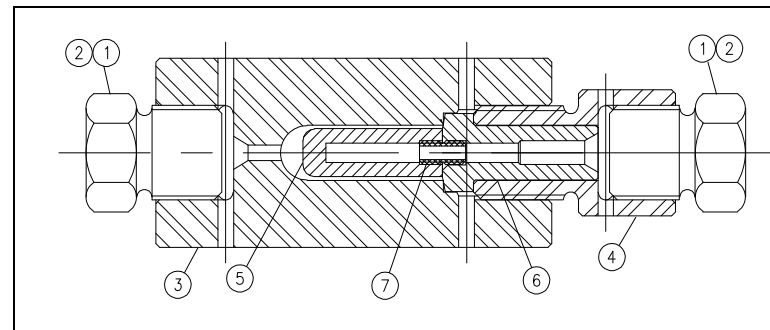



Table 12-29
High Pressure Water Filter Assemblies

Item	Part Number	Description	Quantity
	BF103473	Inline Water Filter, .56	
1	AF413972	HP Gland, Outlet	1
2	AF303473	Seal Head, Outlet	1
3	AF503473	Filter Element	1
4	BF203473	Filter Body	1
5	AF913972	HP Gland, Inlet	1
6	10074599	O-Ring, .38 x .50 x .06	1
7	AF403473	Seal Head, Inlet	1

HP Inline Water Filter, .56

Table 12-30
High Pressure Swivel Joints

Item	Part Number	Description	Quantity
	CJ211388	HP Swivel Joint, Straight, .25, M/F	
1	10084713	Thrust Needle Bearing	1
2	10094647	Thrust Washer	2
3	10103505	Setscrew, 6-32 x 1/8	1
4	CJ311388	Swivel Body	1
5	CJ401288	Swivel Bushing	1
6	CJ501288	Spindle, .25	1
7	BJ701288	Cap Assembly	1
8	BJ201388	Seal Assembly	1
	BJ701288	Cap Assembly	
1	CJ801288	Cap, .25/.38, M/F	1
2	10144442	Swivel Bushing	1

Figure 12-30: High Pressure Swivel Joints
HP Swivel Joint, Straight, M/F Connection, .25

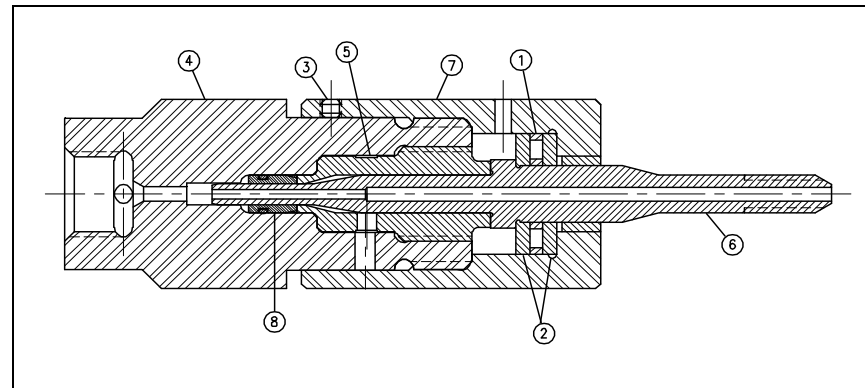

Table 12-30
High Pressure Swivel Joints

Item	Part Number	Description	Quantity
	CJ218088	HP Swivel Joint, Straight, .25, F/F	
1	10084713	Thrust Needle Bearing	1
2	10094647	Thrust Washer	2
3	10103505	Setscrew, 6-32 x 1/8	1
4	10154680	Clamp Collar	1
5	CJ318088	Spindle, .56	1
6	CJ418088	Cap, .25	1
7	CJ311388	Swivel Body	1
8	CJ401288	Swivel Bushing	1
9	BJ201388	Seal Assembly	1

HP Swivel Joint, Straight, F/F Connection, .25

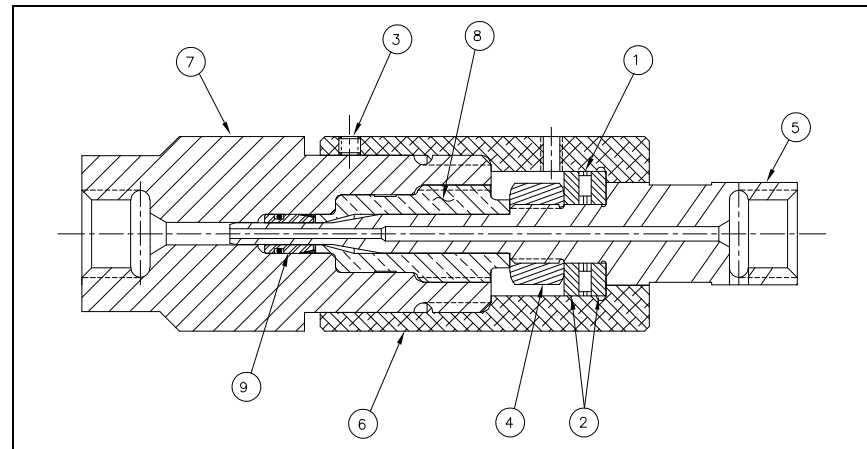

Table 12-30
High Pressure Swivel Joints

Item	Part Number	Description	Quantity
	10134708	HP Swivel Joint, Straight, .38, M/F	
1	10084713	Thrust Needle Bearing	1
2	10094647	Thrust Washer	2
3	10103505	Setscrew, 6-32 x 1/8	1
4	10134716	Swivel Body	1
5	CJ401288	Swivel Bushing	1
6	49899602	Spindle, .38	1
7	BJ701288	Cap Assembly	1
8	BJ201388	Seal Assembly	1
9	10078913	HP Gland, Anti-Vibration	2
10	10078715	HP Collar	2

HP Swivel Joint, Straight, M/F Connection, .38

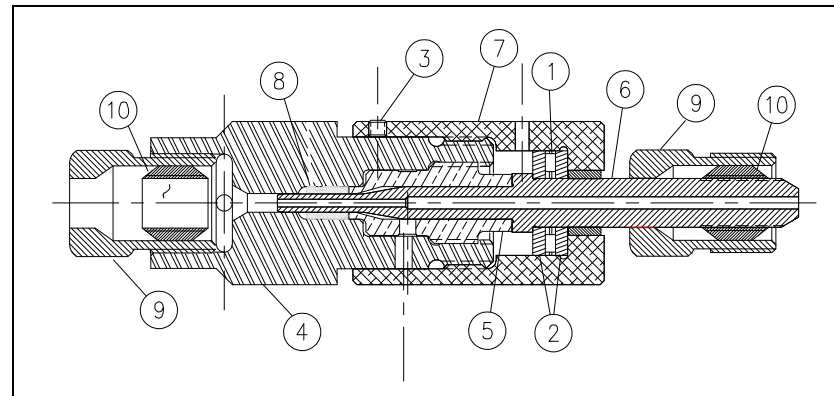

Table 12-30
High Pressure Swivel Joints

Item	Part Number	Description	Quantity
	CJ201288	HP Swivel Joint, 90D, .25, M/F	
1	10084713	Thrust Needle Bearing	1
2	10094647	Thrust Washer	2
3	10103505	Setscrew, 6-32 x 1/8	1
4	DJ301288	Swivel Body	1
5	CJ401288	Swivel Bushing	1
6	CJ501288	Spindle, .25	1
7	BJ701288	Cap Assembly	1
8	BJ201388	Seal Assembly	1

HP Swivel Joint, 90D, M/F Connection, .25

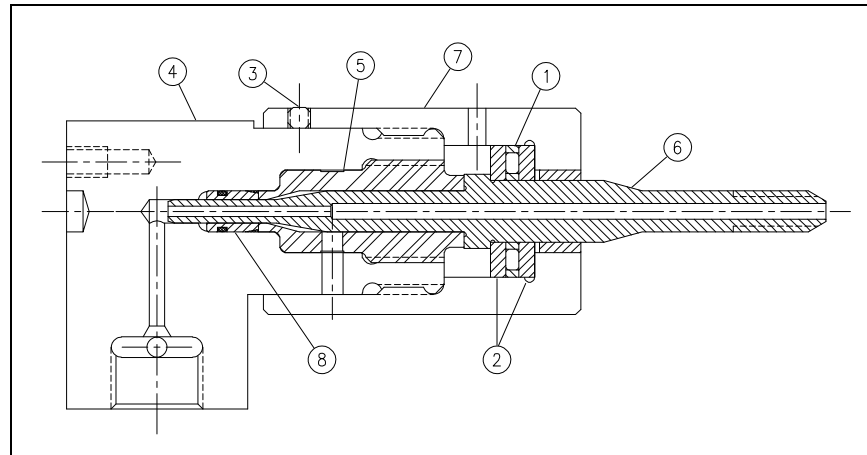

Table 12-30
High Pressure Swivel Joints

Item	Part Number	Description	Quantity
	CJ218188	HP Swivel Joint, 90D, .25, F/F	
1	10084713	Thrust Needle Bearing	1
2	10094647	Thrust Washer	2
3	10103505	Setscrew, 6-32 x 1/8	1
4	10154680	Clamp Collar	1
5	CJ318088	Spindle, .56	1
6	CJ418088	Cap, .25	1
7	DJ301288	Swivel Body	1
8	CJ401288	Swivel Bushing	1
9	BJ201388	Seal Assembly	1

HP Swivel Joint, 90D, F/F Connection, .25

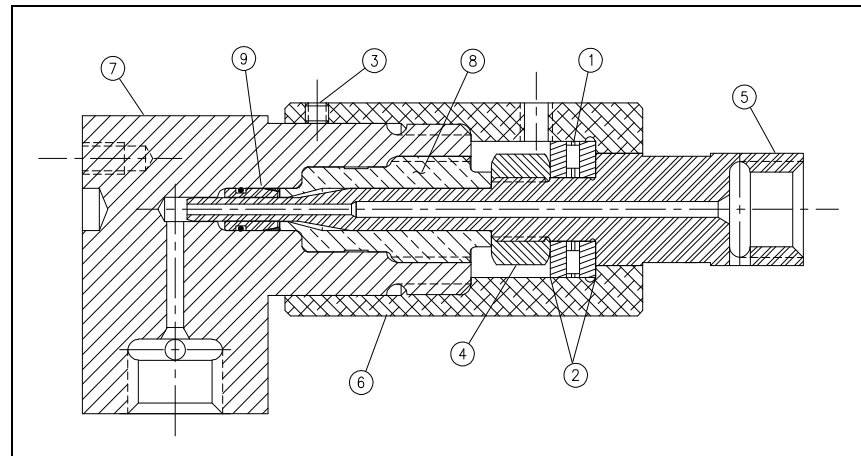
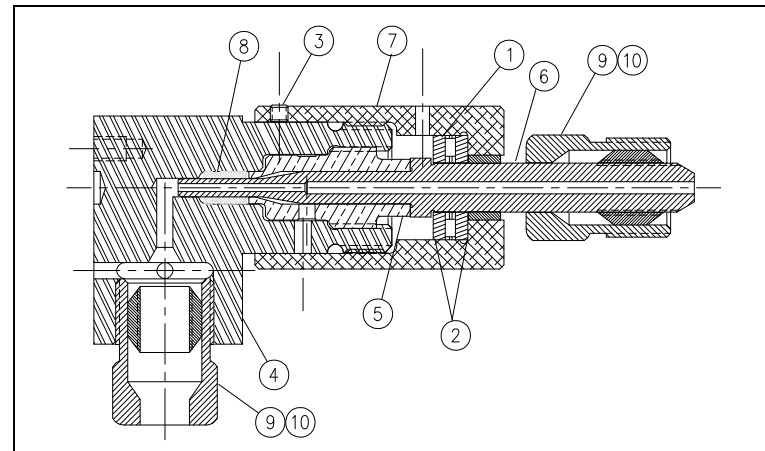

Table 12-30
High Pressure Swivel Joints

Item	Part Number	Description	Quantity
	10134682	HP Swivel Joint, 90D, .38, M/F	
1	10084713	Thrust Needle Bearing	1
2	10094647	Thrust Washer	2
3	10103505	Setscrew, 6-32 x 1/8	1
4	10134690	Swivel Body	1
5	CJ401288	Swivel Bushing	1
6	49899602	Spindle, .38	1
7	BJ701288	Cap Assembly	1
8	BJ201388	Seal Assembly	1
9	10078913	HP Gland, Anti-Vibration	2
10	10078715	HP Collar	2

HP Swivel Joint, 90D, M/F Connection, .38

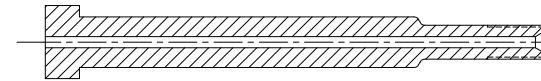

**Table 12-31
Nozzle Tubes**

Part Number	Description		Part Number	Description	
	Actual in (mm)	Nominal in (mm)		Actual in (mm)	Nominal in (mm)
10181113	2.65 (67.31)	3.00 (76.20)	10138451	8.65 (219.71)	9.00 (228.60)
10138402	3.65 (92.91)	4.00 (101.60)	05136023	9.15 (232.41)	9.50 (241.30)
10138410	4.65 (118.11)	5.00 (127.0)	10138469	9.65 (245.11)	10.00 (254.0)
10138428	5.65 (143.51)	6.00 (152.40)	05106224	10.15 (257.81)	10.50 (266.70)
05131784	5.91 (150.11)	6.25 (158.75)	05136031	10.65 (270.51)	11.00 (279.40)
10138436	6.65 (168.91)	7.00 (177.80)	05013735	11.65 (295.91)	12.00 (304.80)
10138444	7.65 (194.31)	8.00 (203.20)	05086913	14.65 (372.11)	15.00 (381.0)
05106224	8.10 (205.74)	8.45 (214.63)			
10138584	3.64 (92.46)	4.00 (101.60)	10138634	7.64 (194.06)	8.00 (203.20)
10138592	4.64 (117.86)	5.00 (127.0)	10138642	8.64 (219.46)	9.00 (228.60)
10138600	5.64 (143.26)	6.00 (152.40)	10138659	9.64 (244.86)	10.00 (254.0)
10138618	6.64 (168.66)	7.00 (177.80)	20432414	13.64 (346.46)	14.00 (355.60)

Figure 12-31: Nozzle Tubes

.38 Nozzle Tube, Nozzle Nut Connection



.38 Nozzle Tube, HP Connection

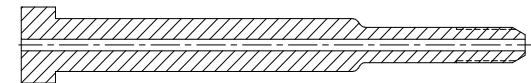

**Table 12-31
Nozzle Tubes**

Part Number	Description		Part Number	Description		
	Actual in (mm)	Nominal in (mm)		Actual in (mm)	Nominal in (mm)	
10138477	2.65 (67.31)	3.00 (76.20)	10138527	7.65 (194.31)	8.00 (203.20)	.56 Nozzle Tube, Nozzle Nut Connection 
10138485	3.65 (92.91)	4.00 (101.60)	10138535	8.65 (219.71)	9.00 (228.60)	
10138493	4.65 (118.11)	5.00 (127.0)	10181105	9.65 (245.11)	10.00 (254.0)	
10138501	5.65 (143.51)	6.00 (152.40)	10193100	11.65 (295.91)	12.00 (304.80)	
10138519	6.65 (168.91)	7.00 (177.80)				
10138667	3.65 (92.91)	4.00 (101.60)	10138709	7.65 (194.31)	8.00 (203.20)	.56 Nozzle Tube, HP Connection 
10138675	4.65 (118.11)	5.00 (127.0)	10138717	8.65 (219.71)	9.00 (228.60)	
10138683	5.65 (143.51)	6.00 (152.40)	10138725	9.65 (245.11)	10.00 (254.0)	
10138691	6.65 (168.91)	7.00 (177.80)	80074446	10.65 (270.51)	11.00 (279.40)	

Table 12-32
Autoline™ Abrasive Nozzle Assembly

Item	Part Number	Description	Quantity
	05078530	Autoline™ Nozzle Assembly, .030 Wear Insert	
	05147970	Autoline™ Nozzle Assembly, .043 Wear Insert	
1	05076971	Nozzle Cap	1
2	05073820	Nozzle Body	1
3	05076955	Wear Insert, .030 x .156	1
	05135827	Wear Insert, .043 x .156	
4	05076989	Feed Tube Adapter	1
5	05077292	Setscrew, 1/4-28	1
6	05081518	O-Ring, .38 x .50 x .06	1
7	05104930	O-Ring, .50 x .63 x .06	2
8	05092887	O-Ring, .75 x .63 x .06	1
9	05078712	Retainer Knob	1
10	05087168	Guard	1
	49885361	Poly Tube, .38	

Figure 12-32: Autoline™ Abrasive Nozzle Assembly

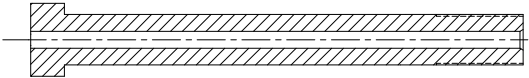
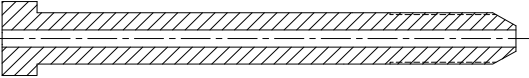
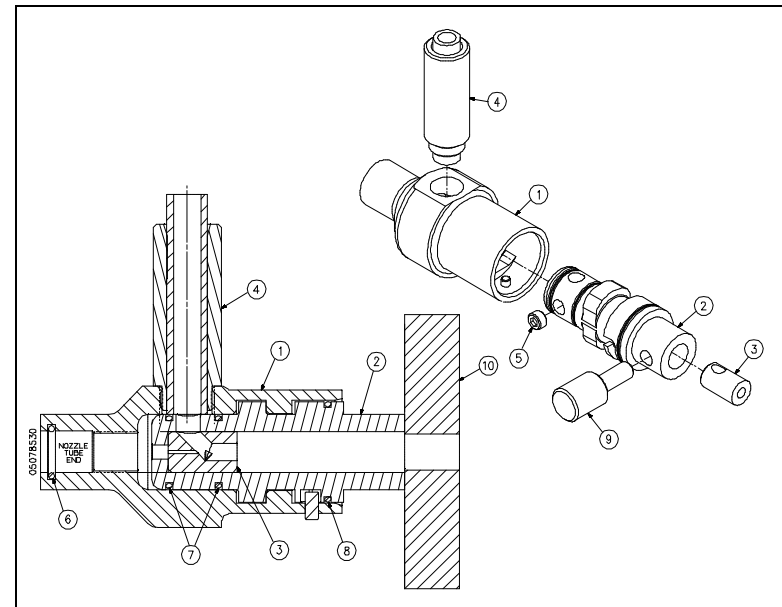

Table 12-33
Autoline™ II Abrasive Nozzle Assembly

Item	Part Number	Description	Quantity
	20453949	Autoline II™ Nozzle Assembly, .030 Wear Insert	
	20454108	Autoline II™ Nozzle Assembly, .043 Wear Insert	
1	20453952	Nozzle Cap	1
2	20453958	Nozzle Body	1
3	20453064	Wear Insert, .030 x .156	1
	20453082	Wear Insert, .043 x .156	
4	20453964	Feed Tube Assembly	1
5	20453973	Handle	1
6	20433398	Setscrew, 8-32	1
7	20453976	T-Knob	1
8	05138821	O-Ring, .69 x .81 x .06	1
9	20445476	O-Ring, .31 x .44 x .06	1
10	05087168	Guard	1
11	05081518	O-Ring, .38 x .50 x .06	1
12	05077078	O-Ring, .38 x .50 x .06	1
	49885361	Poly Tube, .38	

Figure 12-33: Autoline™ II Abrasive Nozzle Assembly

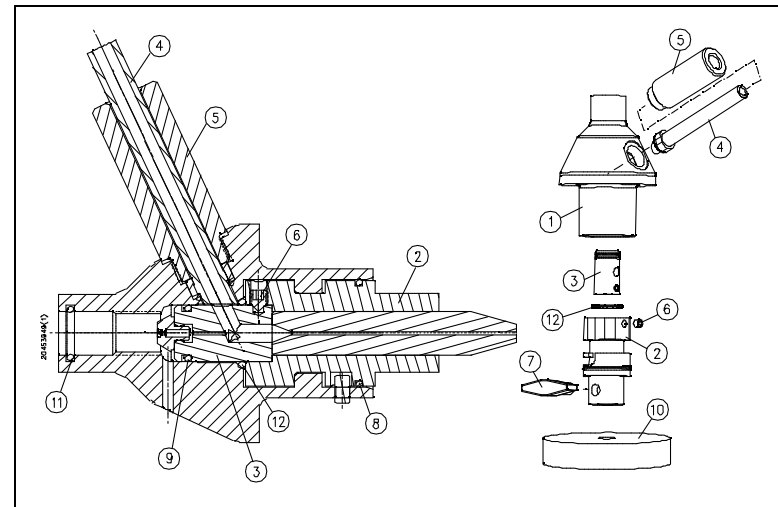

Table 12-34
Autoline™ Sapphire Orifice

Part Number	Description	Part Number	Description
05109079	0.007" (0.178 mm)	20412569	0.013" (0.330 mm)
05109087	0.008" (0.203 mm)	05109137	0.014" (0.356 mm)
05109095	0.009" (0.229 mm)	20448541	0.016" (0.406 mm)
05109103	0.010" (0.254 mm)	05114913	0.018" (0.457 mm)
05109111	0.011" (0.279 mm)	80086671	0.019" (0.482 mm)
05109129	0.012" (0.305 mm)	05114921	0.020" (0.508 mm)

Figure 12-34: Autoline™ Sapphire Orifice

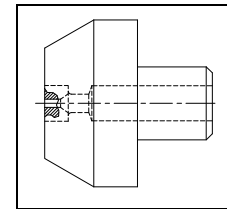

Table 12-35
Autoline™ Diamond Orifice

Part Number	Description	Part Number	Description
20448625	0.004" (0.102 mm)	05136098	0.013" (0.330 mm)
05063847	0.007" (0.178 mm)	05077037	0.014" (0.356 mm)
05112537	0.008" (0.203 mm)	80075781	0.015" (0.381 mm)
05084504	0.009" (0.229 mm)	05121512	0.016" (0.406 mm)
05077029	0.010" (0.254 mm)	05114905	0.018" (0.457 mm)
05101753	0.011" (0.279 mm)	80086663	0.019" (0.482 mm)
05077300	0.012" (0.305 mm)	05114897	0.020" (0.508 mm)

Figure 12-35: Autoline™ Diamond Orifice

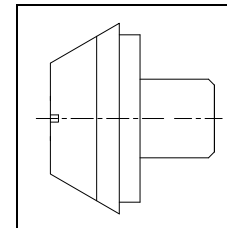

Table 12-36
Pneumatic Control Valve, Normally Closed
10138824

Item	Part Number	Description	Quantity
1	10177855	Pneumatic Actuator Assembly, NC	1
2	10189181	Valve Body	1
3	BV701184	HP Gland	1
4	10188233	Brass Backup Ring	1
5	20428052	Seal Assembly	1
6	20435636	Valve Stem	1
7	10178697	Valve Seat	1

Figure 12-36: Pneumatic Control Valve, NC

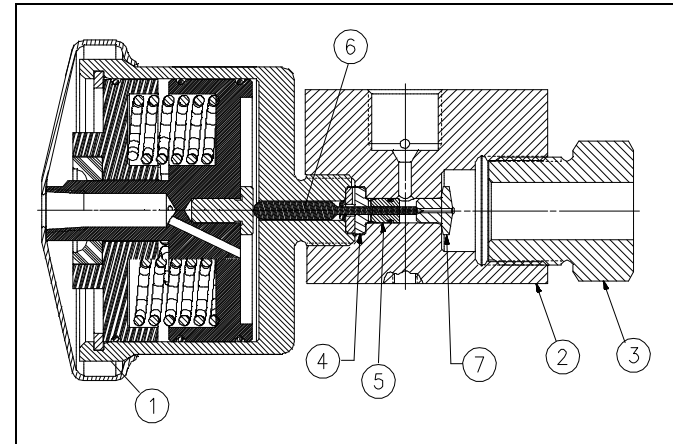

Table 12-37
Pneumatic Actuator Assembly, Normally Closed
10177855

Item	Part Number	Description	Quantity
1	05145990	Piston	1
2	20411554	Cylinder Cap	1
3	10177780	Wiper Seal	1
4	10177772	Retaining Ring	1
5	10176543	Pneumatic Cylinder	1
6	10177806	O-Ring, 2.63 x 2.75 x .06	3
7	05054119	Compression Spring, .72 x .105 x 1.50	6
8	49895584	O-Ring, .08 x .20 x .06	1
9	10187250	SST Backup Ring	1
10	00080028	Cover	1
	10178291	Warning Decal	

Figure 12-37: Pneumatic Actuator Assembly, NC

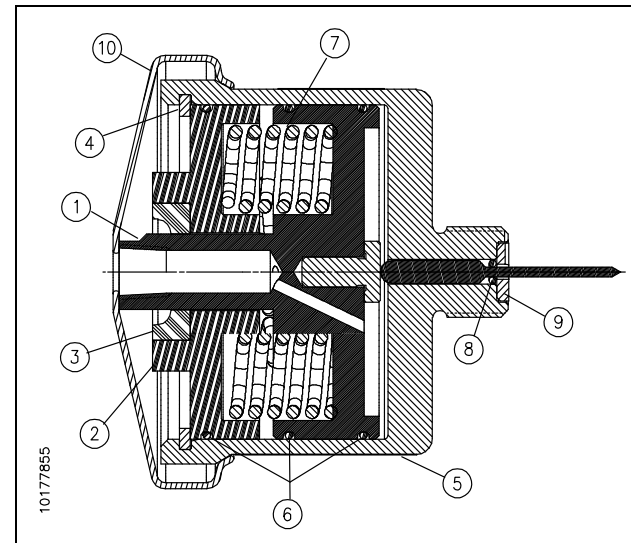

Table 12-38
Pneumatic Control Valve, Normally Open
10184760

Item	Part Number	Description	Quantity
1	10189553	Pneumatic Actuator Assembly	1
2	10189181	Valve Body	1
3	BV701184	HP Gland Fitting	1
4	10188233	Brass Backup Ring	1
5	20428052	Seal Assembly	1
6	20435636	Valve Stem	1
7	10178697	Valve Seat	1

Figure 12-38: Pneumatic Control Valve, NO

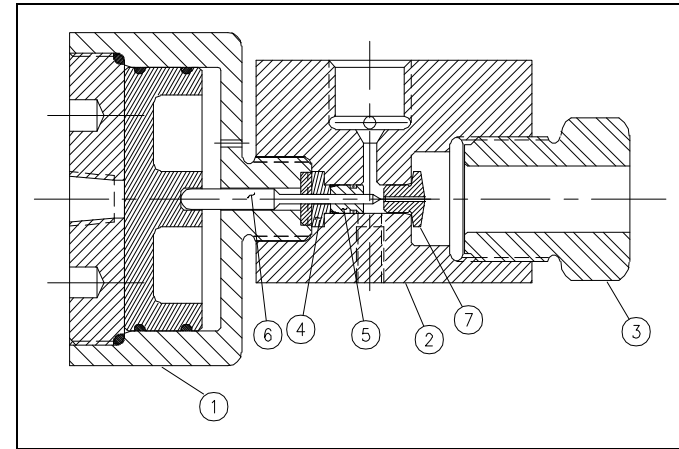

Table 12-39
Pneumatic Actuator Assembly, Normally Open
10189553

Item	Part Number	Description	Quantity
1	BV401184	Pneumatic Cylinder	1
2	BV601184	Cylinder Head	1
3	BV501184	Piston	1
4	10187250	SST Backup Ring	1
5	10074714	O-Ring, 2.44 x 2.63 x .09	1
6	10074565	O-Ring, 2.25 x 2.38 x .06	2

Figure 12-39: Pneumatic Actuator Assembly, NO

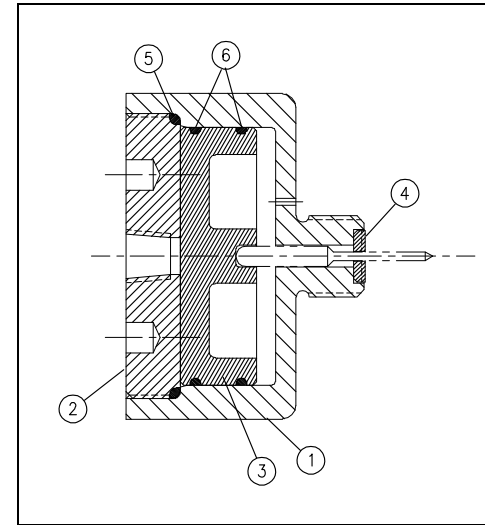



Table 12-40
Bulk High Pressure Tubing

Part Number	Description
10064376	.25 x .083, 20 ft (6.10 m)
10184810	.25 x .083, up to 40 ft (12.19 m)
10064665	.38 x .125, 20 ft (6.10 m)
10061190	.56 x .188, 20 ft (6.10 m)

High Pressure Tubing also available coned, threaded and/or autofrettaged

Figure 12-40: Bulk High Pressure Tubing Coned/Threaded Both Ends

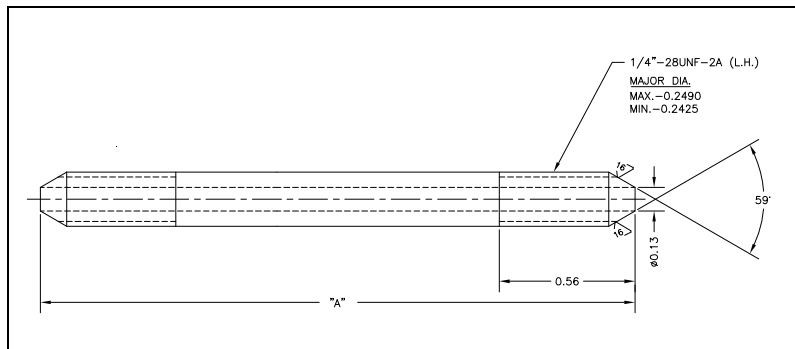

Table 12-41
High Pressure Fitting and Valve Assemblies

Part Number	Description		Part Number	Description	
10079028	Coupling, .25 x .25, F/F	<p>HP Coupling</p> 	10079473	Bushing, .38 x .25, F/M	<p>HP Bushing</p> 
10079614	Coupling, .38 x .25, F/F		10079432	Bushing, .38 x .25, M/F	
10078905	Coupling, .38 x .38, F/F		10079424	Bushing, .56 x .25, F/M	
10078145	Coupling, .56 x .25, F/F		10079580	Bushing, .56 x .25, M/F	
10079531	Coupling, .56 x .38, F/F		10079655	Bushing, .56 x .38, F/M	
10078640	Coupling, .56 x .56, F/F		10079457	Bushing, .56 x .38, M/F	
10078160	Bulkhead Coupling, .38 x .38, F/F	<p>HP Bulkhead Coupling</p> 	49832801	Bushing, .75 x .56, F/M	<p>HP Cross</p> 
49830581	Bulkhead Coupling, .56 x .38, F/F		10097228	Cross, .25	
10079705	Bulkhead Coupling, .56 x .56, F/F		10078038	Cross, .38	
20424785	Bulkhead Coupling, .75 x .75, F/F		10079168	Cross, .56	
10079051	Elbow, .25 x .25, 90D	<p>HP Elbow</p> 	49832652	Cross, .75	
10078780	Elbow, .38 x .38, 90D		10079481	Tee, .25	
10078525	Elbow, .56 x .56, 90D		10078590	Tee, .38	
49832645	Elbow, .75 x .75, 90D		10079465	Tee, .56	
			49832660	Tee, .75	



Table 12-41
High Pressure Fitting and Valve Assemblies

Part Number	Description		Part Number	Description	
10078426	Collar, .25	HP Collar 	10116333	Adapter Cone, .25	HP Cone Adapter 
10078715	Collar, .38		10078509	Adapter Cone, .38	
10079119	Collar, .56		10079291	Adapter Cone, .56	
49832686	Collar, .75		20448815	Adapter Cone, .75	
10078459	Gland, .25	HP Gland 	10078244	Plug, .25	HP Plug 
10078129	Gland, .38		10079523	Plug, .38	
10078608	Gland, .56		10078772	Plug, .56	
49832678	Gland, .75				
10078699	Anti-Vibration Gland, .25	Anti-Vibration Gland 			
10078913	Anti-Vibration Gland, .38				
10093573	Anti-Vibration Gland, .56				

Table 12-41
High Pressure Fitting and Valve Assemblies

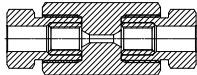
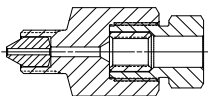
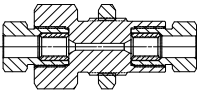
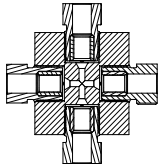
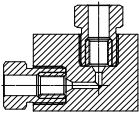
Part Number	Description		Part Number	Description	
10079259	2 Way Straight, .25	<p>2-Way Straight Valve</p>	10079002	2 Way Angle, .25	<p>2-Way Angle Valve</p>
10078863	2 Way Straight, .35		10078749	2 Way Angle, .38	
10078889	2 Way Straight, .56		10079275	2 Way Angle, .56	
20432554	2 Way Straight, .75				
10097533	3 Way/1 Pressure Valve, .38	<p>3-Way Valve</p>	05137724	3 Way/2 Pressure Valve, .38	<p>3-Way Valve</p>
10097541	3 Way/1 Pressure Valve, .56		10153500	3 Way/2 Pressure Valve, .56	

NO.	DESCRIPTION	DATE	APPROVED
1	REVISED PER JOS	5/13/03	BR
2	REVISED LP WATER CIRCUIT REF ECR REV02572	7/27/04	JOS
3	ADDED PROPORTIONAL PRESSURE OPTION REF ECR REV03288	10/24/05	SAGE A.
4	ADDED EXTERNAL OIL/AIR HT EXCH OPTION REF ECR REV05101	7/20/09	JOS
5	MOVED WATER VALVE FROM INLET TO OUTLET REF ECR REV05465	7/16/10	JAM/HR

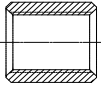
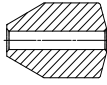
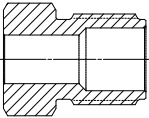
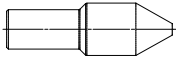
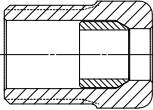
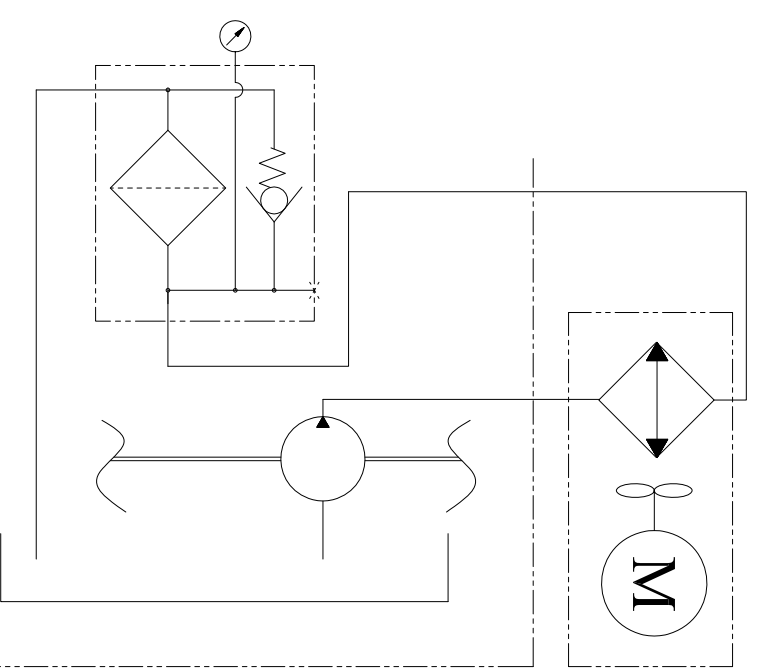
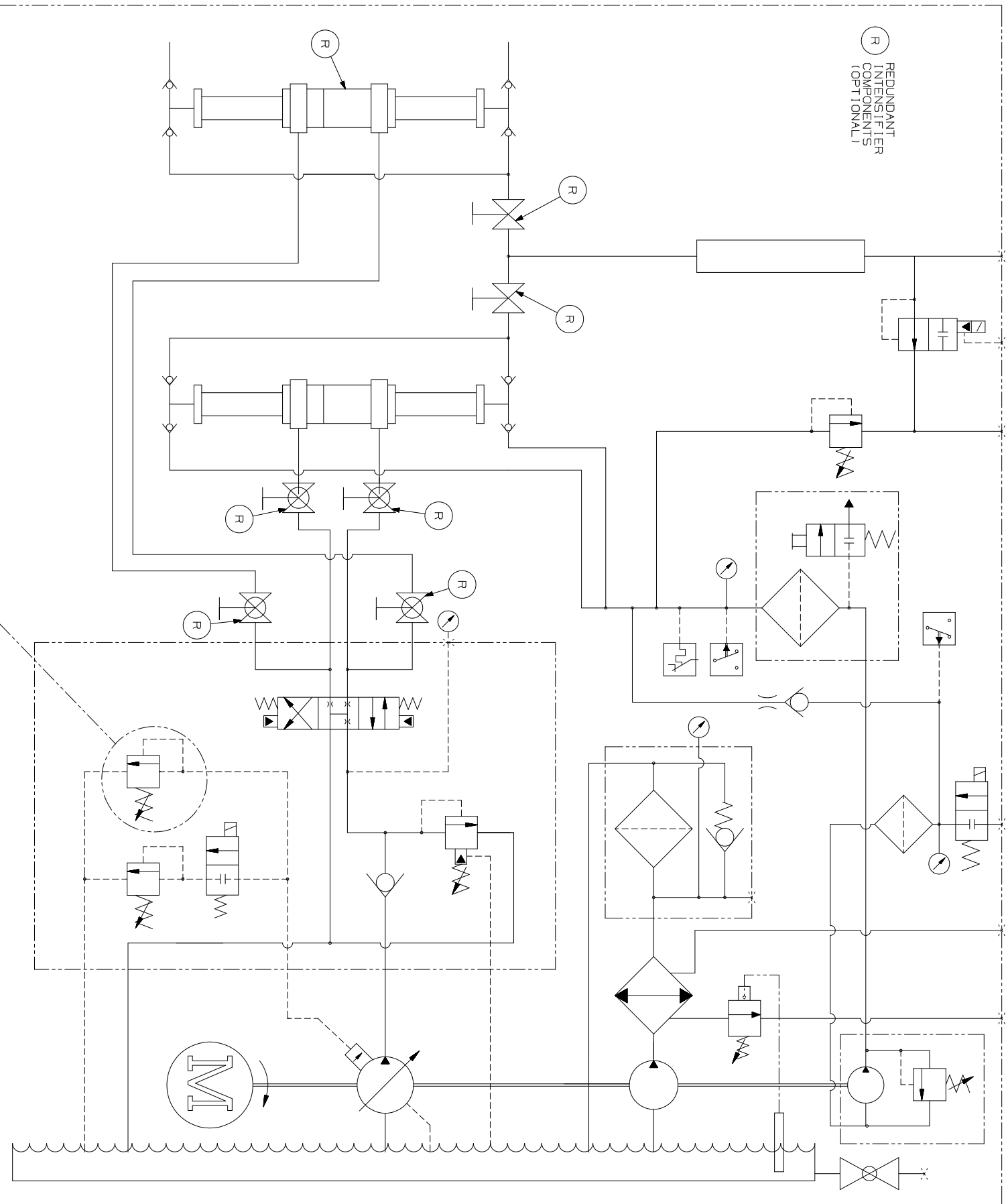

OPTIONAL
EXTERNAL OIL/AIR COOLER

Copyright © 2003 KMT Waterjet Systems All Rights Reserved		PROPRIETARY NOTICE		STANDARD TOLERANCES UNLESS OTHERWISE NOTED: ALL DIMENSIONS ON COMMON CENTRELINE COARDE TO .005 BREAK SHARP EDGES AND CORNERS .015 SURFACE FINISH 6.3 STANDARD TOLERANCES: XX = ±.015 XXX = ±.005 ANGLE = ±2°		GD&T TO ASME Y14.5M 1994		KMT Waterjet SHEETS			
WARNING ! The export or reexport of this drawing or a product produced by KMT Waterjet Systems, Inc. without the prior written consent of KMT Waterjet Systems, Inc. is prohibited. Export Administration regulations and other applicable governmental restrictions or regulations.		This document contains confidential and trade secret information and retention of the document accepts the document in confidence and agrees that, except as authorized in writing, the recipient shall not disclose the confidential or trade secret information therein; (2) not copy the document; (3) not disclose to others either the document, or the confidential or trade secret information therein; and (4) upon demand return the document, all copies thereof, and all material copied therefrom.		REF: DWS 05075510 DRAWN BY & DATE BONNIE RUMBEL CHECKED BY H. SHIELDS DATE 5/02		HARDNESS —		ENC. ASSEMBLY H. SHIELDS 5/02		TITLE SCHEMATIC - SYSTEM SLV/SLV REDUNDANT	
NEXT ASSEMBLY		SCALE		THIRD ANGLE PROJECTION		TITLE BLOCK REGION 2		SHEET 1 OF 1		REV. 5	

NO	DESCRIPTION	DATE	APPROVED
14	ADDED OIL/AIR COOLER FAN (OPTIONAL) REF. ESK. REV.05258.	7/9/10 J.M.H.	7/9/10 J.S.

DWG. NO. 49836604D
SHEET 1 OF 14

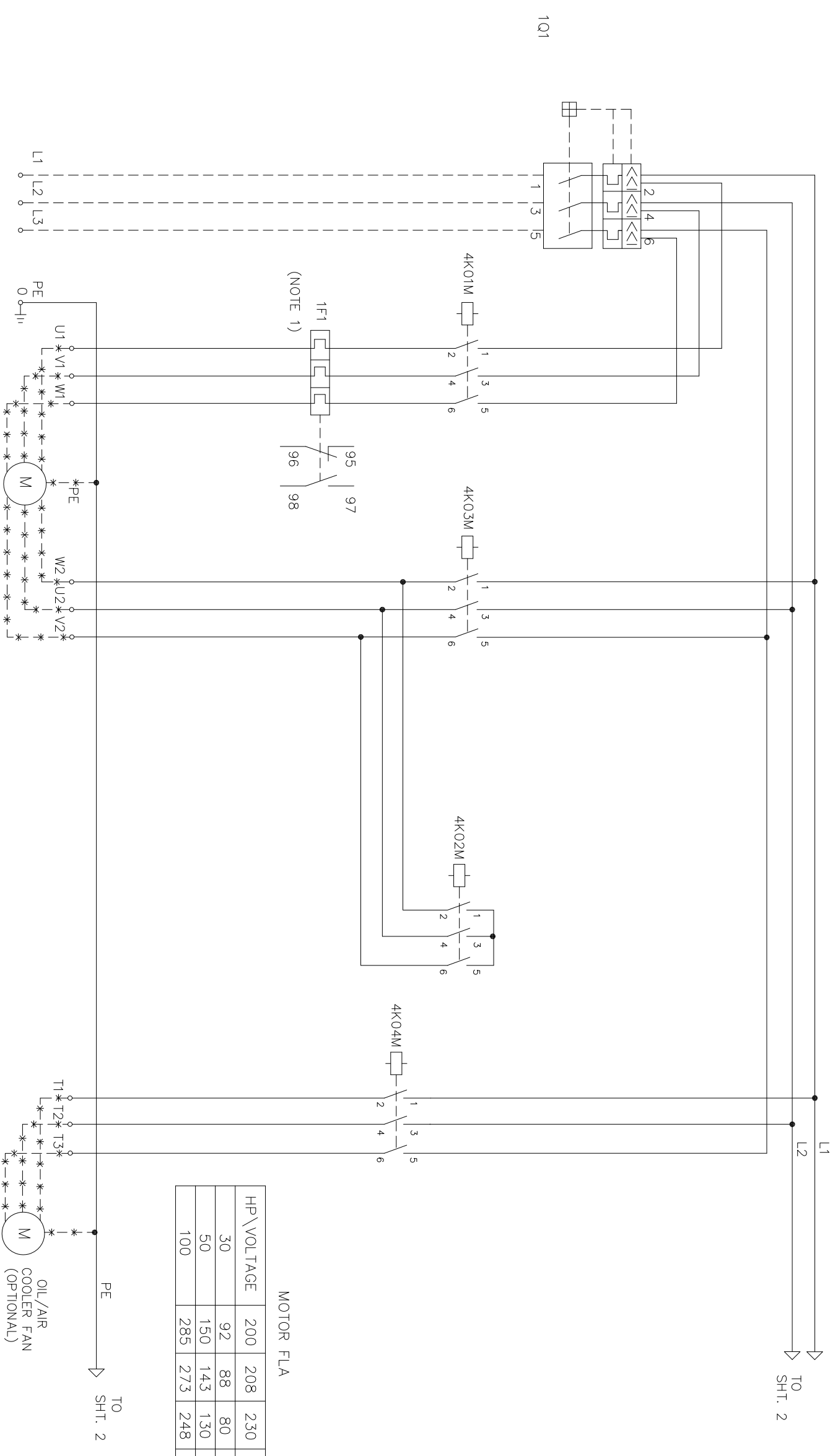

MOTOR FLA

HP \ VOLTAGE	200	208	230	400	415	460
30	92	88	80	46	44	40
50	150	143	130	75	72	65
100	285	273	248	143	138	124

- NOTE:
- FOR UNITS WITH ELECTRONIC OVERLOAD SET CLASS 10 AND SET OVERLOAD TO 57% OF FLA

NOTE: WIRING BY CUSTOMER IN ACCORDANCE WITH LOCAL REGULATIONS. WIRING BY KMT EXTERNAL TO PANEL ALL AC CONTROL VOLTAGE WIRES MUST BE RED IN COLOR



Copyright ©2003 KMT Waterjet Systems All Rights Reserved		PROPRIETARY NOTICE		STANDARD TOLERANCES UNLESS OTHERWISE NOTED: ALL DIMENSIONS IN INCHES [mm]		GD&T TO ASME Y14.5M 1994		KMT Waterjet			
WARNING ! The export or reexport of this drawing is subject to U.S. Export Administration regulations and other applicable governmental restrictions or regulations.		This document contains confidential and trade secret information, is the property of KMT Waterjet Systems, and is loaned and retention of the document occurs in confidence and agrees that, except as authorized in writing by KMT Waterjet Systems, it will not use the information for any other purpose, will not disclose the trade secret information therein, (2) not copy the document or its contents, and (3) not disclose to others either the document or its contents. Upon completion of the need to retain the document, it will be destroyed and all copies thereof, and all material copied therefrom.		HEAT TREAT SURFACE FINISH STANDARD TOLERANCES: XX = ±.003 XXX = ±.015 X.XXX = ±.02		DRAWN BY & DATE B. RUMBEL 7/7/02		CHECKED BY DATE 7/10/02		KMT Waterjet	
				HARDNESS				SCALE: THIRD ANGLE PROJECTION		DWG. NO. 49836604D	
								TITLE BLOCK REVISION 2		SHEET 1 OF 5	



REV. NO.		DESCRIPTION		DATE	APPROVED
7	ADDED 210 AND 211 NUMBERS	01/12/04	02/14		
8	CHANGED E-STOP PER FOR REV02797	10/12/04	10	G.F.N.	
11	ADDED FUSE DETAIL AND NOTE 1 PER FOR REV04437	4/28/08	4/28/08	JOS	
12	TRANSFORMER CONNECTIONS MODIFIED PER FOR REV04900	5/22/08	5/22/08	JOS	

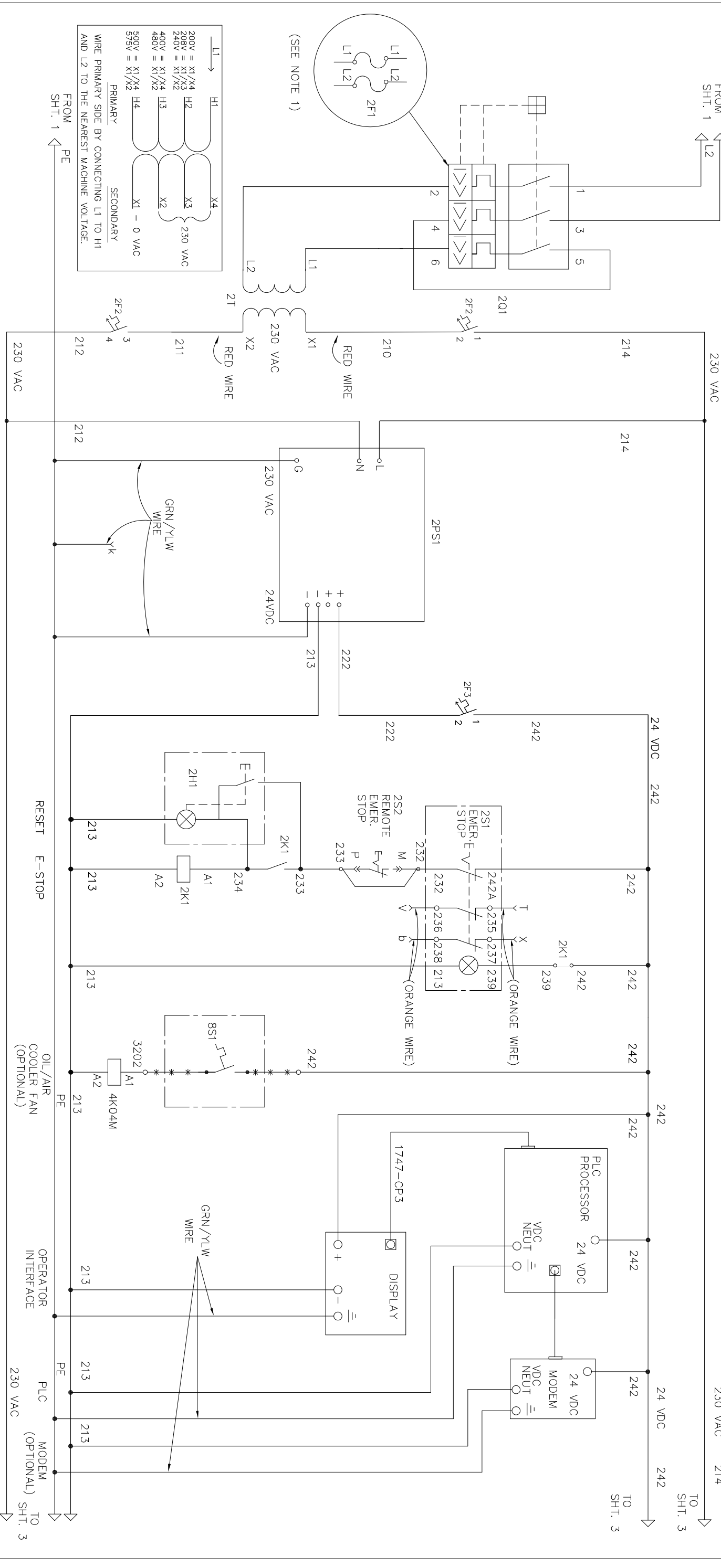

NOTE 1: REPLACE BREAKER WITH FUSES ON CSA PANELS ONLY.

--- WIRING BY CUSTOMER IN ACCORDANCE WITH LOCAL REGULATIONS.
 --* WIRING BY KMT EXTERNAL TO PANEL
 ALL AC CONTROL VOLTAGE WIRES MUST BE RED IN COLOR

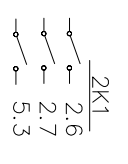

Copyright ©2003 KMT Waterjet Systems All Rights Reserved	PROPRIETARY NOTICE	STANDARD TOLERANCES UNLESS OTHERWISE NOTED: ALL DIMENSIONS IN INCHES [mm] COMMON CENTRELINE COAXIAL TO .005 BREAK SHARP EDGES AND CORNERS 015 SURFACE FINISH X.XX = ±.003 X.XX = ±.015 X.XX = ±.020 ANGLE = .42°	GD&T TO ASME Y14.5M 1994 REF. DIM 051485490 B. RUMBEL CHECKED BY: GPN DATE: 7/02	HEAT TREAT HARDNESS	ENC. APPROVAL & DATE	SCALE: -	THIRD ANGLE PROJECTION	REV. NO. 49836604D	REV. 14
<p>WARNING !</p> <p>The export or reexport of this drawing is prohibited without the prior written approval of KMT Waterjet Systems. This drawing is subject to U.S. Export Administration regulations and other applicable governmental restrictions or regulations.</p>		<p>PROPRIETARY NOTICE</p> <p>This document contains confidential and trade secret information, is the property of KMT Waterjet Systems, and is loaned and retention of the document exceeds the document in confidence and agrees that, except as authorized in writing by KMT Waterjet Systems, it will not use the information contained herein for any other purpose. (3) not disclose to others either the document or the trade secret information therein; (2) not copy the document or the trade secret information therein; (1) not disclose the document or other applicable governmental restrictions or regulations.</p>		<p>HEAT TREAT</p> <p>HARDNESS</p>		<p>SCALE: -</p> <p>THIRD ANGLE PROJECTION</p>		<p>REV. NO. 49836604D</p> <p>REV. 14</p>	



SCHEM-ELECTRICAL
SLV, Y-DELTA

REVISIONS		DATE	APPROVED
NO	DESCRIPTION	DATE	APPROVED
1	REVISED PER REV01787	10/21/02	BR
		10/21/02	GH

FROM SHT. 2 230 VAC 214

230 VAC TO SHT 4 214

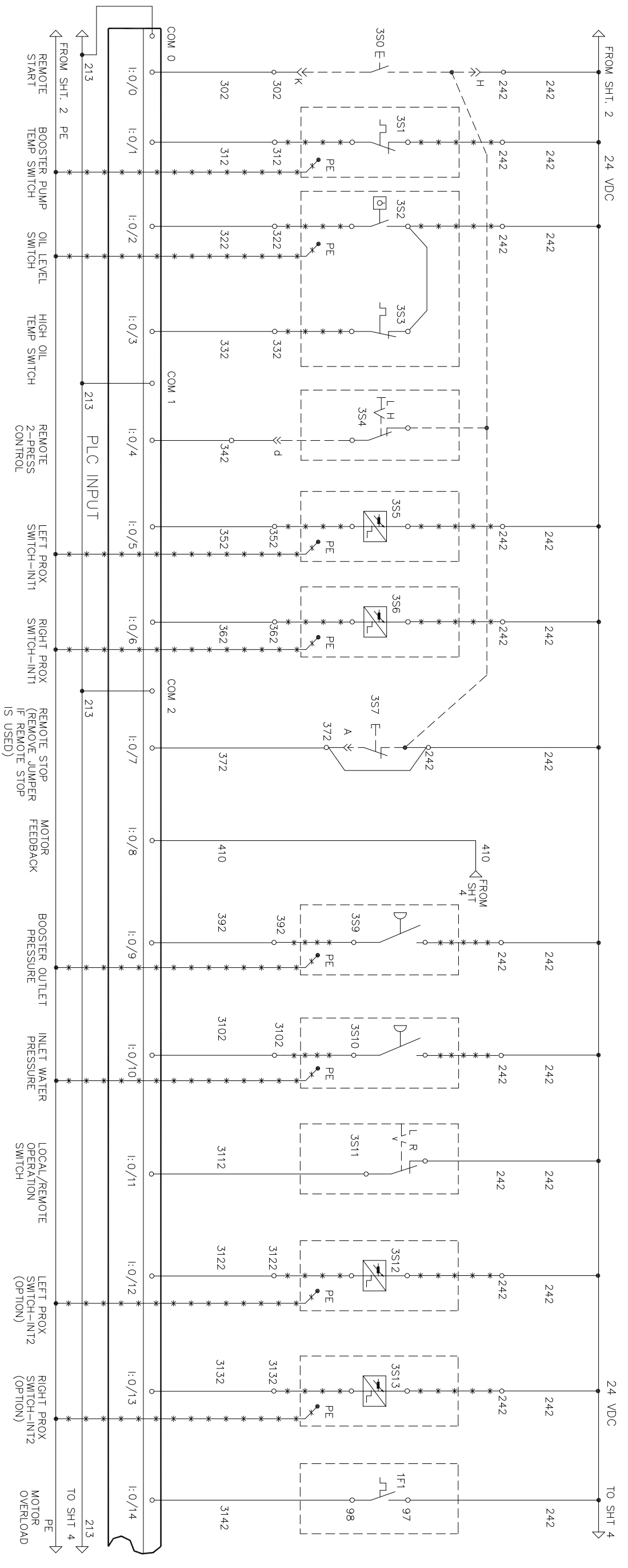

----- WIRING BY CUSTOMER IN ACCORDANCE WITH LOCAL REGULATIONS

--* WIRING BY KMT EXTERNAL TO PANEL

ALL AC CONTROL VOLTAGE WIRES MUST BE RED IN COLOR

TO SHT. 3 212

FROM SHT. 2 230 VAC 212

230 VAC TO SHT 4 212

Copyright ©2003 KMT Waterjet Systems All Rights Reserved		PROPRIETARY NOTICE		STANDARD TOLERANCES		GD&T TO ASME Y14.5M 1994				TITLE			
WARNING ! The export or reexport of this drawing is subject to U.S. Export Administration regulations and other applicable governmental restrictions or regulations.		This document contains confidential and trade secret information, is the property of KMT Waterjet Systems, and is loaned and retention of the document exceeds the document in confidence and agrees that, except as authorized in writing by KMT Waterjet Systems, it will not use the information for any other purpose, will not disclose the document to others either the document or the information contained therein, (2) not copy the document, (3) not disclose to others either the document or the information contained therein, and will return the document upon demand return the document, all copies thereof, and all material copied therefrom.		UNLESS OTHERWISE NOTED: COMMON CENTRILINE COAXIAL TO .005 BREAK SHARP EDGES AND CORNERS 015		ALL DIMENSIONS IN INCHES [mm]		REF. DIM. 051485490				TITLE	
				SURFACE FINISH -				B. RUMBEL 051485490				SCHEM-ELECTRICAL SLV, Y-DELTA	
				HEAT TREAT -				CHECKED BY DATE 7/02				49836604D	
				HARDNESS -				ENG. APPROVAL & DATE				REV. 14	
				DRAWING APPROVAL & DATE				SCALE: THIRD ANGLE PROJECTION				SHEET 3 OF 5	

REVISIONS		
NO	DESCRIPTION	DATE
2	REVISED PER REV01825	11/27/02
6	ADDED 5 AMP FUSE TO SOLENOID. PER REV02308	12/01/03
9	REVISED PER REV02963	2/3/05
10	POWER FOR ELEC OVAL PER REV03650	7/14/06

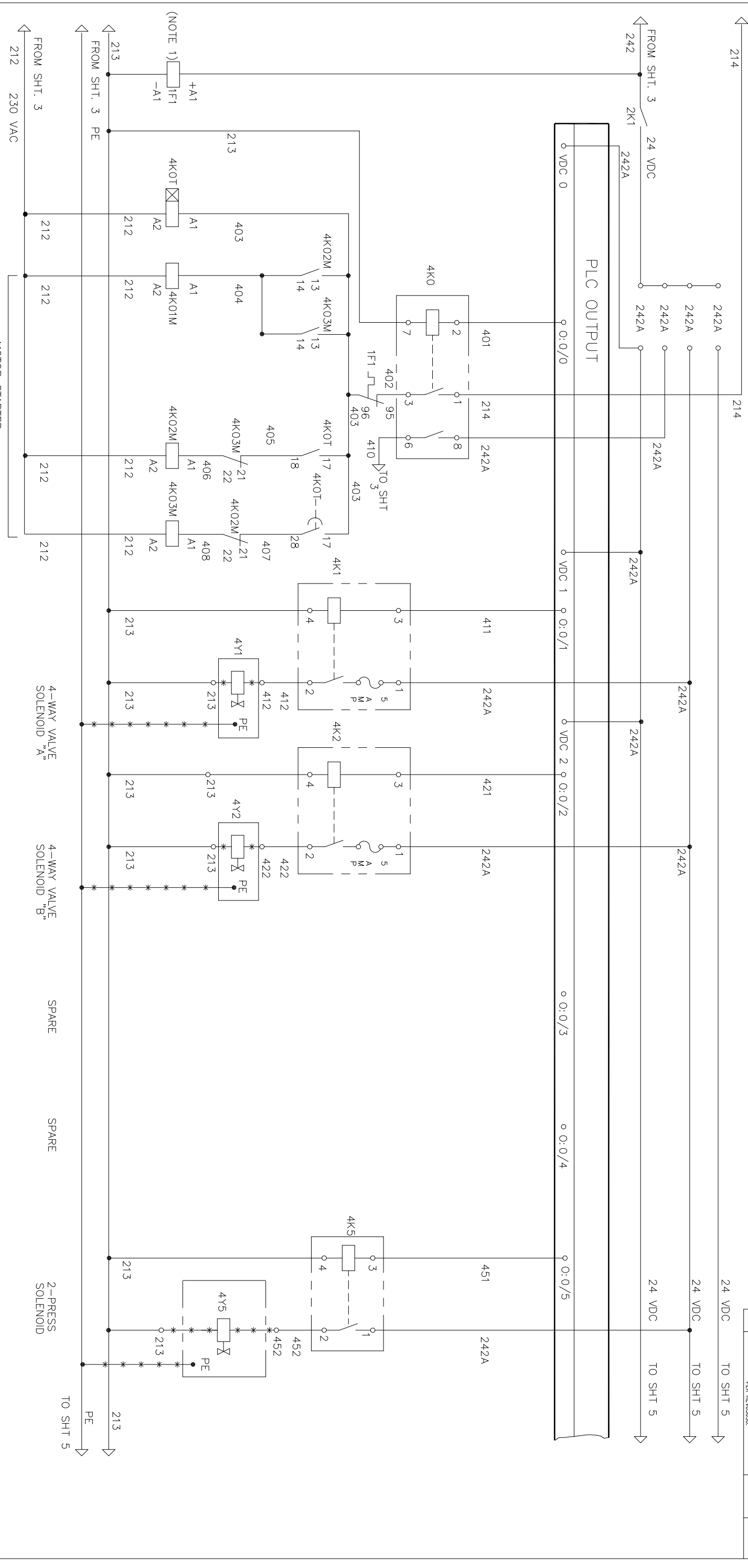

NOTE: 1. FOR USE ONLY WITH ELECTRONIC OVERLOADS THAT REQUIRE 24V POWER.
 WIRING BY CUSTOMER IN ACCORDANCE WITH LOCAL REGULATIONS.
 WIRING BY KMT EXTERNAL TO PANEL
 ALL AC CONTROL VOLTAGE WIRES MUST BE RED IN COLOR

Copyright ©2003 KMT Waterjet Systems All Rights Reserved	PROPRIETARY NOTICE	STANDARD TOLERANCES UNLESS OTHERWISE NOTED: ALL DIMENSIONS IN INCHES [mm] COMMON CENTERLINE COAXIAL TO .005 BREAK SHARP EDGES AND CORNERS 015 SURFACE FINISH HEAT TREAT X.XX = ±.003 X.XXX = ±.015 X.XXXX = ±.020 ANGLE = .25	GD&T TO ASME Y14.5M 1994 REF. DIM 051485490 DRAWN BY & DATE B. RUMBEL 7/1/02 CHECKED BY 7/1/02 ENG. APPROVAL & DATE		TITLE SCHEM-ELECTRICAL SLV, Y-DELTA 49836604D REV. 14
--	--------------------	---	--	--	---

REVISIONS			
NO	DESCRIPTION	DATE	APPROVED
2	REVISED PER REV01826	11/7/02	GRN
3	A & B WERE 1 & 2, REV01931.	1/21/03	BR
4	ON VLV, 4 WAS 3 & 5 WAS 4, PER REV02116.	05/29/03	K.A.L.
5	REVISED PER REV02169	7/11/03	BR
6	CHANGED VALVE CONFIGURATION, PER REV02308.	12/01/03	K.A.L.
9	REVISED PER REV02963	2/3/05	J.Milner
13	CHANGED WIRING ON PRESS. TRANSDUCER REF. FOR REV02586	3/20/10	J.Milner

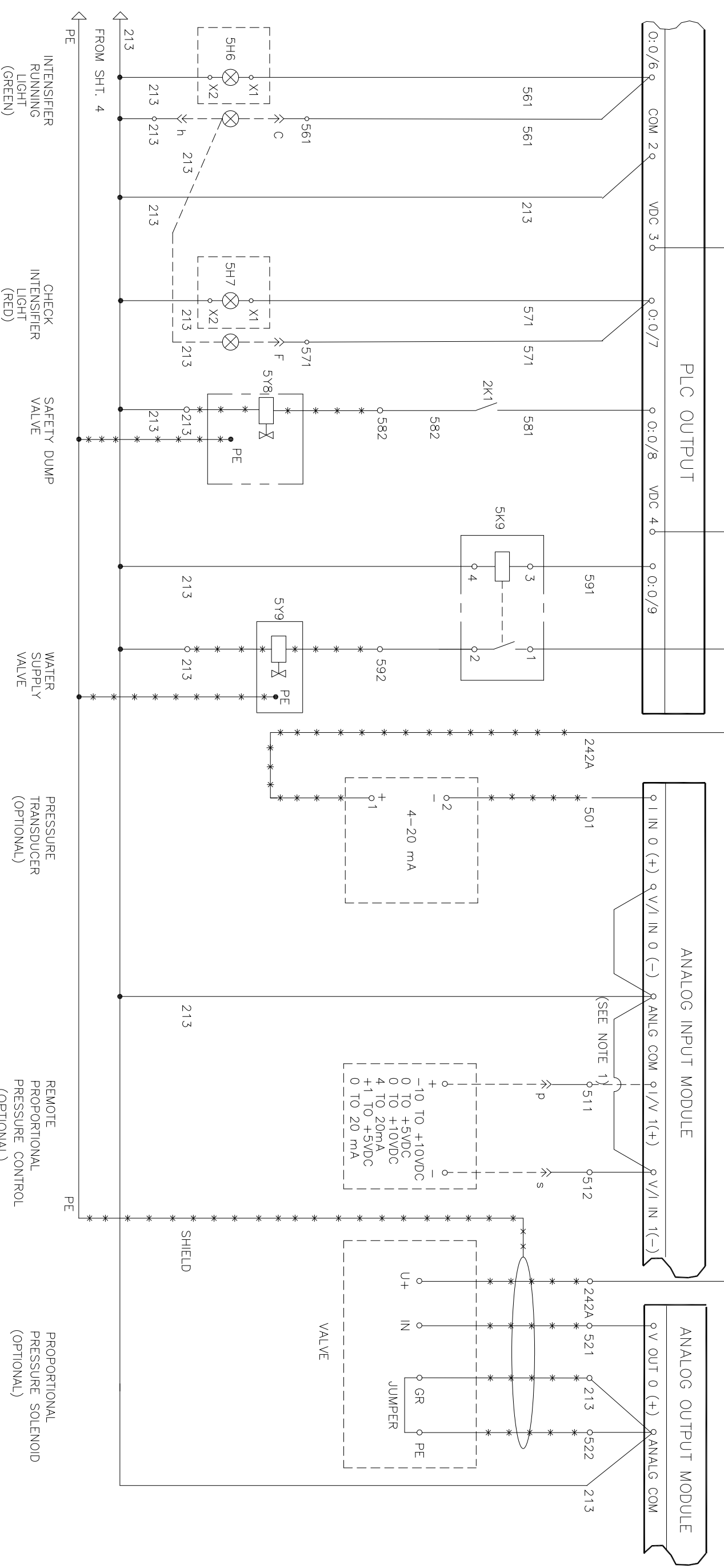

NOTE: VOLTAGE OR CURRENT CONTROL SPECIFIED BY CUSTOMER.
 USE I IN 1(+), FOR CURRENT OR V IN 1(+), FOR
 VOLTAGE CONTROL ON ANALOG MODULE.

----- WIRING BY CUSTOMER IN ACCORDANCE WITH LOCAL REGULATIONS
 --*- WIRING BY KMT EXTERNAL TO PANEL
 ALL AC CONTROL VOLTAGE WIRES MUST BE RED IN COLOR

Copyright ©2003 KMT Waterjet Systems All Rights Reserved		PROPRIETARY NOTICE		STANDARD TOLERANCES UNLESS OTHERWISE NOTED: ALL DIMENSIONS IN INCHES [mm] WATERJET BREAK SHARP EDGES AND CORNERS 015 HEAT TREAT ORDERED BY DATE CHECKED BY DPN 7/02 ENG. APPROVAL & DATE		REF. DWG 051485490		DRAWN BY & DATE B. RUMBEL 7/02		KMT Waterjet		TITLE SCHEM-ELECTRICAL SLV, Y-DELTA			
WARNING ! The export or reexport of this drawing is prohibited without the prior written approval of KMT Waterjet Systems. This drawing is subject to U.S. Export Administration regulations and other applicable governmental restrictions or regulations.		This document contains confidential and trade secret information, is the property of KMT Waterjet Systems, and its use, reproduction, distribution, or release of the document without the written consent of KMT Waterjet Systems is prohibited. The information contained herein is confidential and proprietary to KMT Waterjet Systems. It is not to be used, copied, or disseminated in any manner without the prior written consent of KMT Waterjet Systems. (1) not disclose to others either the document or the information contained herein; (2) not copy the document or the information contained herein; (3) not disclose the need to retain the document or the information contained herein; (4) upon demand return the document, all copies thereof, and all material copied therefrom.		GD&T TO ASME Y14.5M 1994		HARDNESS		SCALE		THIRD ANGLE PROJECTION		TITLE BLOCK REVISION 2		SHEET 5 OF 5	

NO	DESCRIPTION	DATE	APPROVED
2	CHANGED SOFTSTARTER SETTINGS	5/18/08	J.O.G./08
4	REVISED DRAWING	5/21/08	J.O.G./08
5	REVISED WMS 21001, L1 AND D05 PER ECR RE006643	2/21/11	J.O.G./11

DWG. NO. 20431430D SH. 1 OF 5

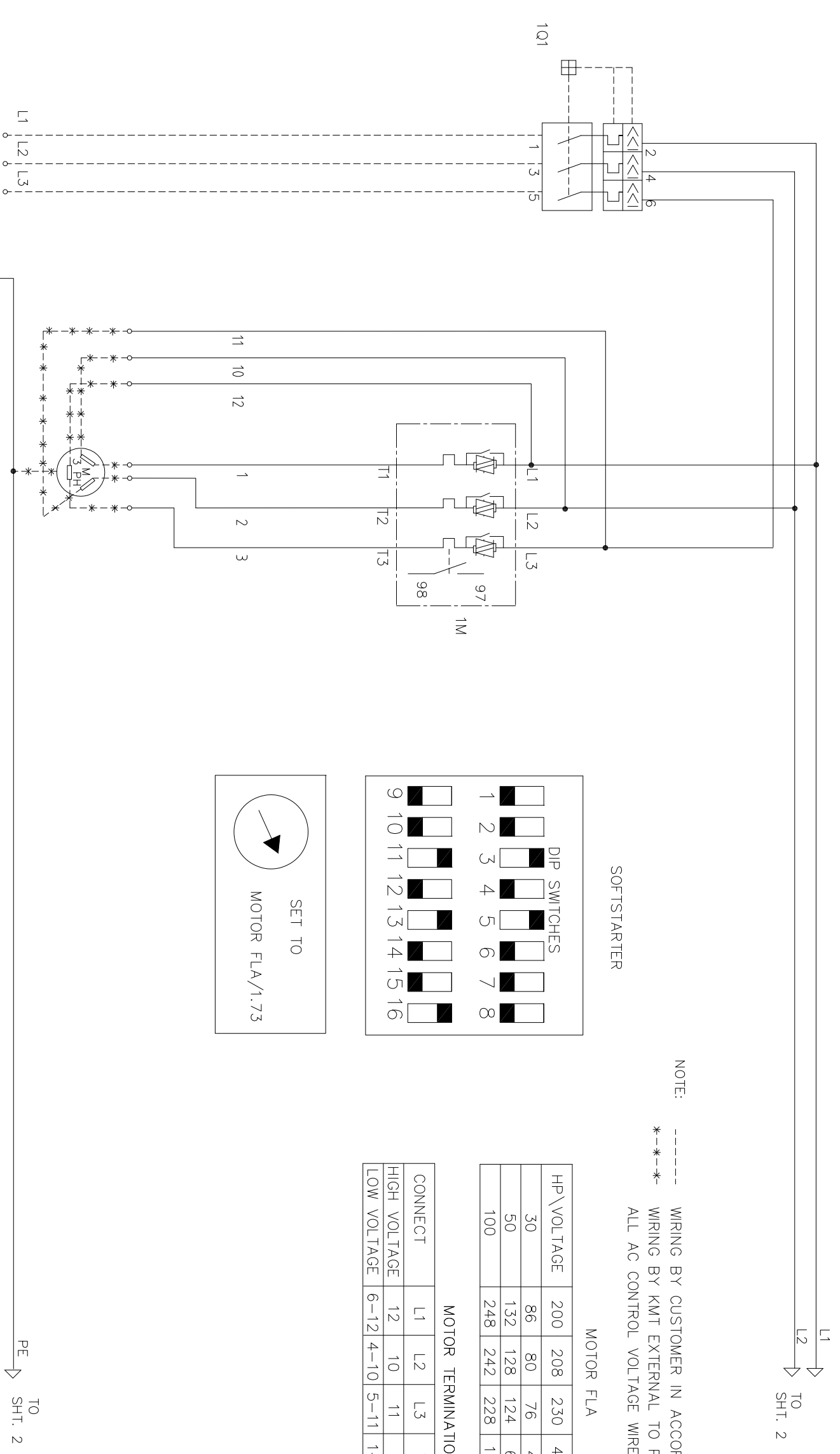

NOTE: -----
 --* WIRING BY CUSTOMER IN ACCORDANCE WITH LOCAL REGULATIONS.
 ALL AC CONTROL VOLTAGE WIRES MUST BE RED IN COLOR

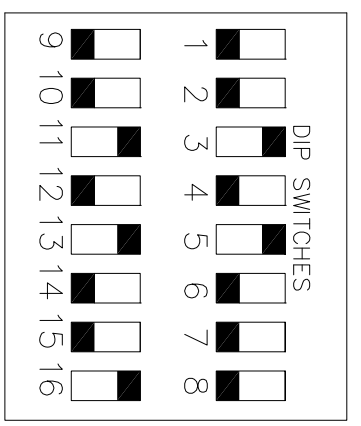

SET TO
 MOTOR FLA/1.73

HP \ VOLTAGE	200	208	230	400	415	460
30	86	80	76	42	43	38
50	132	128	124	66	64	58
100	248	242	228	124	120	109

CONNECT	MOTOR TERMINATION		
	L1	L2	L3
HIGH VOLTAGE	12	10	11
LOW VOLTAGE	6-12	4-10	5-11

Copyright ©2003 KMT Waterjet Systems All Rights Reserved		PROPRIETARY NOTICE		STANDARD TOLERANCES UNLESS OTHERWISE NOTED: GD&T TO ASME Y14.5M 1994		HEAT TREAT —		DRAWN BY & DATE GPN 9/05		CHECKED BY & DATE GPN 9/05		ENGR. APPROVAL & DATE —		SCALE: —		TITLE: ELEC. SCHEMATIC SLV, SOFT START		REV. 5			
WARNING ! The export or reexport of this drawing is prohibited without the prior written consent of KMT Waterjet Systems. This drawing is subject to U.S. Export Administration regulations and other applicable governmental restrictions or regulations.		This document contains confidential and trade secret information, is the property of KMT Waterjet Systems, and is loaned and retention of the document accepts the document in confidence and agrees that, except as authorized in writing by KMT Waterjet Systems, it will not use the information contained herein for any other purpose, and will not disclose to others either the document or the trade secret information therein; (2) not copy the document; (3) not disclose to others either the document or the trade secret information therein; (4) upon completion of the work upon which the document was prepared, return the document, all copies thereof, and all material copied therefrom.		ALL DIMENSIONS IN INCHES [mm]		BREAK SHARP EDGES AND CORNERS 015		—		—		—		—		—		—		—	



—
NEXT ASSEMBLY

REVISONS		DATE	APPROVED
NO	DESCRIPTION	DATE	APPROVED
3	TRANSFORMER CONNECTIONS MODIFIED PER ECR REV046606.	5/22/08	JOS

DRW. NO. 20431430D SHEET 2 OF 5

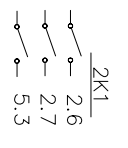
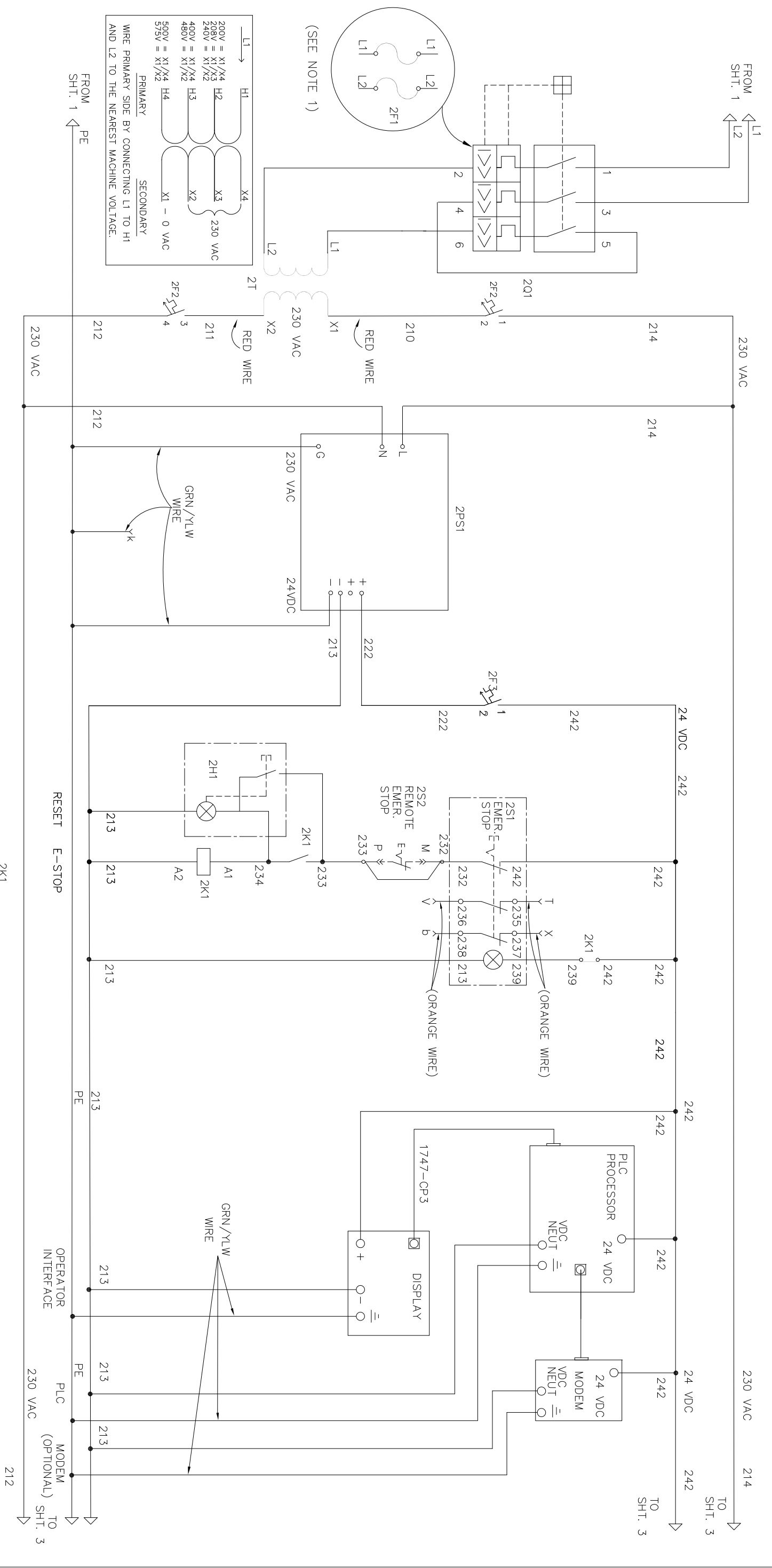

NOTE: 1. REPLACE BREAKER WITH FUSES ON CSA PANELS ONLY.

----- WIRING BY CUSTOMER IN ACCORDANCE WITH LOCAL REGULATIONS.
 ----*-- WIRING BY KMT EXTERNAL TO PANEL
 ALL AC CONTROL VOLTAGE WIRES MUST BE RED IN COLOR

Copyright ©2003 KMT Waterjet Systems All Rights Reserved	PROPRIETARY NOTICE	STANDARD TOLERANCES UNLESS OTHERWISE NOTED: GD&T TO ASME Y14.5M 1994	HEAT TREAT —	DRG. APPROVAL & DATE 9/05	SCALE: —	TITLE ELEC. SCHEMATIC SLV, SOFT START	DRW. NO. 20431430D	DATE 5/22/08	APPROVED JOS
WARNING ! The export or reexport of this drawing is prohibited under U.S. Export Administration regulations and other applicable governmental restrictions or regulations.	This document contains confidential and trade secret information, is the property of KMT Waterjet Systems, and is loaned and retention of the document occurs the document in confidence and agrees that, except as authorized in writing by KMT Waterjet Systems, it will not use the information contained herein for any other purpose. (3) not disclose to others either the document or the trade secret information therein; (2) not copy the document or other information contained herein; (1) not disseminate the document or other information contained herein; upon demand return the document, all copies thereof, and all material copied therefrom.	HEAT TREAT —	DRG. APPROVAL & DATE 9/05	SCALE: —	TITLE ELEC. SCHEMATIC SLV, SOFT START	DRW. NO. 20431430D	DATE 5/22/08	APPROVED JOS	

DRW. NO.	20431430D	SHT.	5	REV.	5
NO.		DESCRIPTION		DATE	APPROVED

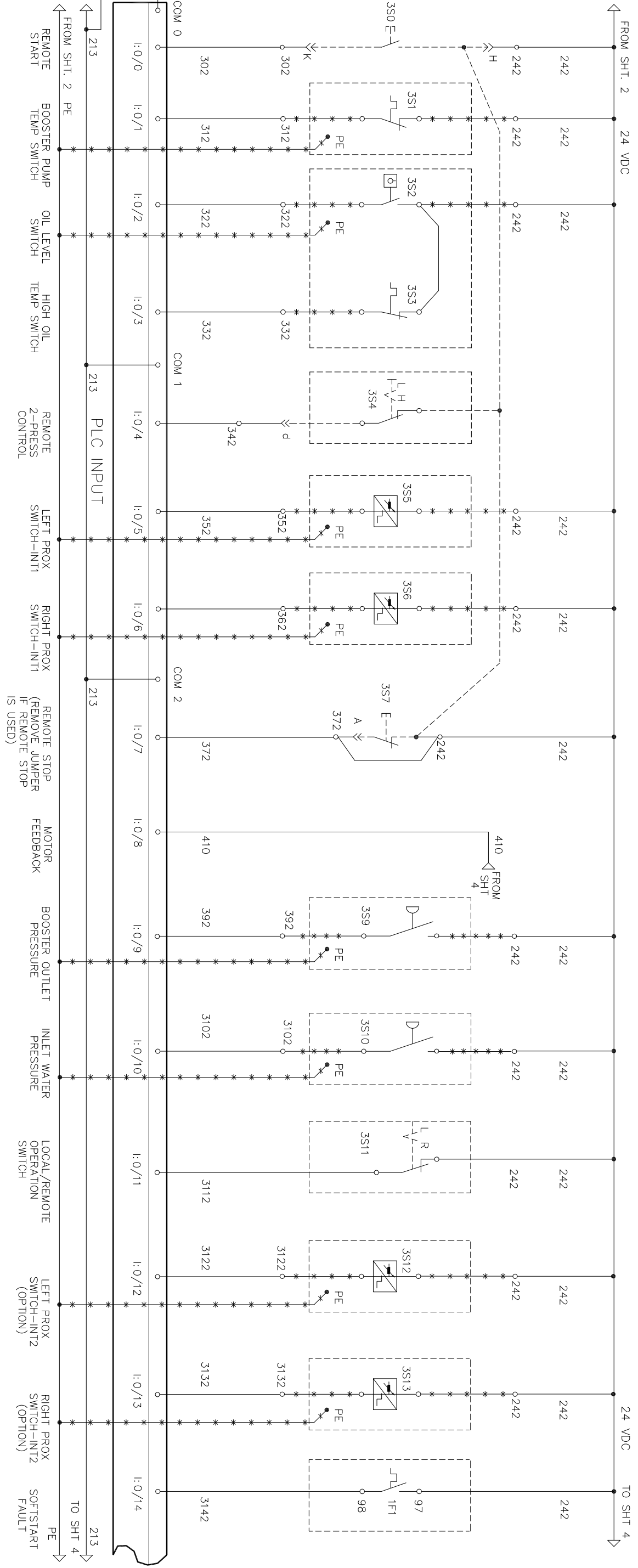

 --*
 WIRING BY CUSTOMER IN ACCORDANCE WITH LOCAL REGULATIONS
 WIRING BY KMT EXTERNAL TO PANEL

ALL AC CONTROL VOLTAGE WIRES MUST BE RED IN COLOR

Copyright ©2003 KMT Waterjet Systems All Rights Reserved		PROPRIETARY NOTICE		STANDARD TOLERANCES UNLESS OTHERWISE NOTED: COMMON CENTERLINE COAXIAL TO .005 BREAK SHARP EDGES AND CORNERS .015 SURFACE FINISH 6.3 STANDARD TOLERANCES: XX = ±.063 XXX = ±.015 ANGLE = .42°		GD&T TO ASME Y14.5M 1994 REF. DWG 05148507 DRAWN BY & DATE GPN 9/05 CHECKED BY DATE 9/05				TITLE ELEC. SCHEMATIC SLV, SOFT START		4300	
<p>WARNING !</p> <p>The export or reexport of this drawing is prohibited by U.S. Export Administration regulations and other applicable governmental restrictions or regulations.</p>				<p>(1) not disclose to others either the document or the information contained therein; (2) not copy the document; (3) not disseminate the document, all copies thereof, and all material copied therefrom.</p>				HARDNESS				SCALE: -	
NEXT ASSEMBLY				DRW. NO.		20431430D		SHEET		3		OF 5	

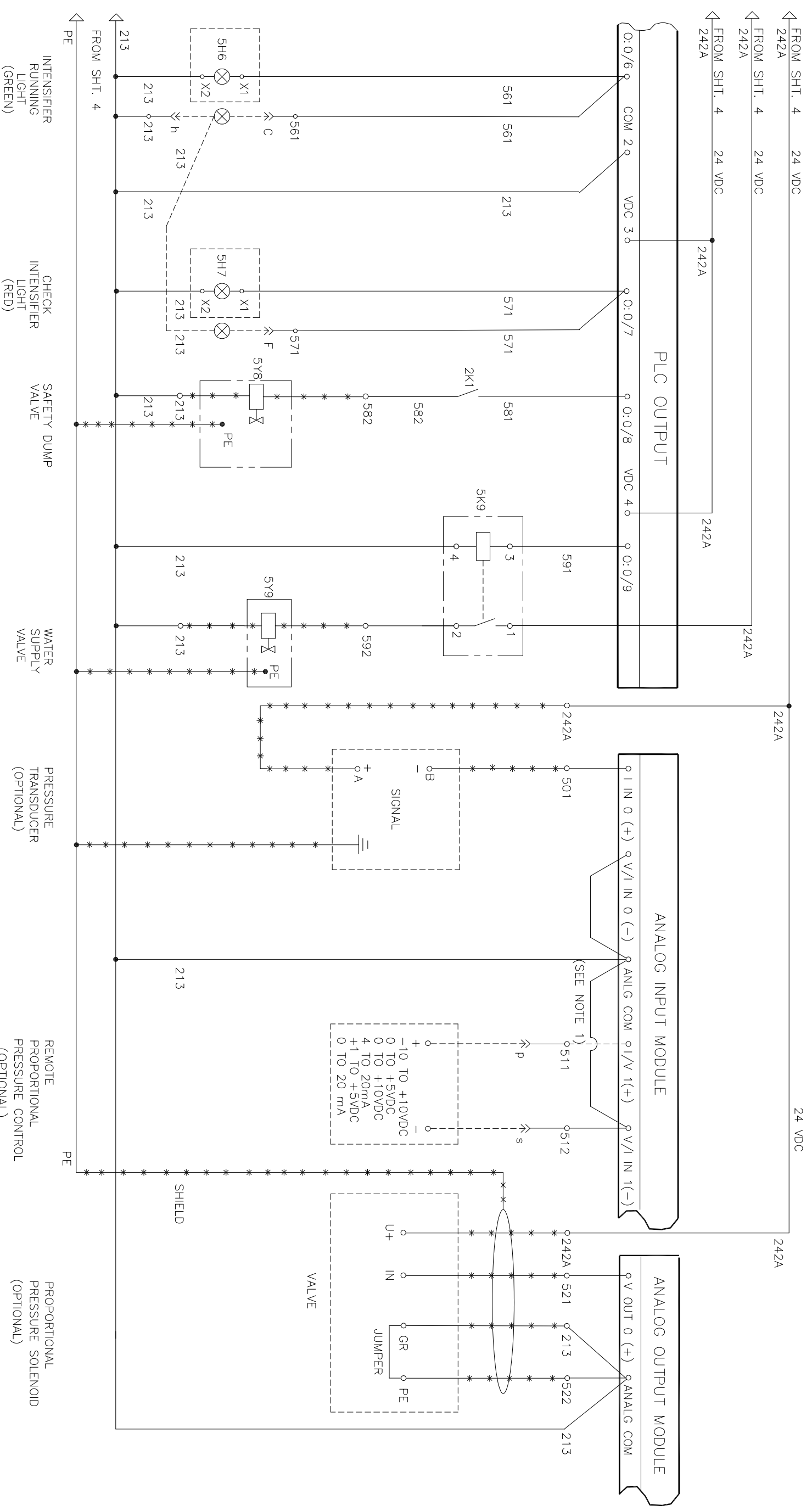

NOTE: VOLTAGE OR CURRENT CONTROL SPECIFIED BY CUSTOMER.
 USE I IN 1(+) FOR CURRENT OR V IN 1(+) FOR
 VOLTAGE CONTROL ON ANALOG MODULE.

----- WIRING BY CUSTOMER IN ACCORDANCE WITH LOCAL REGULATIONS
 --*-*- WIRING BY KMT EXTERNAL TO PANEL
 ALL AC CONTROL VOLTAGE WIRES MUST BE RED IN COLOR

Copyright ©2003 KMT Waterjet Systems All Rights Reserved	PROPRIETARY NOTICE	STANDARD TOLERANCES UNLESS OTHERWISE NOTED: ALL DIMENSIONS IN INCHES [mm] WATERJET BREAK SHARP EDGES AND CORNERS 015 HEAT TREAT ORDERED BY DATE 9/05 DWG. APPROVAL & DATE	REF. DWG 05148507	DRW. NO. KMT Waterjet	TITLE ELEC. SCHEMATIC SLV, SOFT START
WARNING ! The export or reexport of this drawing is prohibited without the prior written consent of KMT Waterjet Systems. This drawing is subject to U.S. Export Administration regulations and other applicable governmental restrictions or regulations.	This document contains confidential and trade secret information, is the property of KMT Waterjet Systems, and is loaned and retention of the document exceeds the document in confidence and agrees that, except as authorized in writing by KMT Waterjet Systems, it will not use the information contained herein for any other purpose. (1) not disclose to others either the document or the trade secret information therein; (2) not copy the document or the trade secret information therein; (3) not disclose the need to retain the document; and upon demand return the document, all copies thereof, and all material copied therefrom.	HEAT TREAT STANDARD TOLERANCES: XX = ±.063 XXX = ±.015 ANGLE = .42°		DRW. NO. 20431430D	TITLE ELEC. SCHEMATIC SLV, SOFT START
Copyright ©2003 KMT Waterjet Systems All Rights Reserved	PROPRIETARY NOTICE	STANDARD TOLERANCES UNLESS OTHERWISE NOTED: ALL DIMENSIONS IN INCHES [mm] WATERJET BREAK SHARP EDGES AND CORNERS 015 HEAT TREAT ORDERED BY DATE 9/05 DWG. APPROVAL & DATE	REF. DWG 05148507	DRW. NO. KMT Waterjet	TITLE ELEC. SCHEMATIC SLV, SOFT START
WARNING ! The export or reexport of this drawing is prohibited without the prior written consent of KMT Waterjet Systems. This drawing is subject to U.S. Export Administration regulations and other applicable governmental restrictions or regulations.	This document contains confidential and trade secret information, is the property of KMT Waterjet Systems, and is loaned and retention of the document exceeds the document in confidence and agrees that, except as authorized in writing by KMT Waterjet Systems, it will not use the information contained herein for any other purpose. (1) not disclose to others either the document or the trade secret information therein; (2) not copy the document or the trade secret information therein; (3) not disclose the need to retain the document; and upon demand return the document, all copies thereof, and all material copied therefrom.	HEAT TREAT STANDARD TOLERANCES: XX = ±.063 XXX = ±.015 ANGLE = .42°		DRW. NO. 20431430D	TITLE ELEC. SCHEMATIC SLV, SOFT START
Copyright ©2003 KMT Waterjet Systems All Rights Reserved	PROPRIETARY NOTICE	STANDARD TOLERANCES UNLESS OTHERWISE NOTED: ALL DIMENSIONS IN INCHES [mm] WATERJET BREAK SHARP EDGES AND CORNERS 015 HEAT TREAT ORDERED BY DATE 9/05 DWG. APPROVAL & DATE	REF. DWG 05148507	DRW. NO. KMT Waterjet	TITLE ELEC. SCHEMATIC SLV, SOFT START
WARNING ! The export or reexport of this drawing is prohibited without the prior written consent of KMT Waterjet Systems. This drawing is subject to U.S. Export Administration regulations and other applicable governmental restrictions or regulations.	This document contains confidential and trade secret information, is the property of KMT Waterjet Systems, and is loaned and retention of the document exceeds the document in confidence and agrees that, except as authorized in writing by KMT Waterjet Systems, it will not use the information contained herein for any other purpose. (1) not disclose to others either the document or the trade secret information therein; (2) not copy the document or the trade secret information therein; (3) not disclose the need to retain the document; and upon demand return the document, all copies thereof, and all material copied therefrom.	HEAT TREAT STANDARD TOLERANCES: XX = ±.063 XXX = ±.015 ANGLE = .42°		DRW. NO. 20431430D	TITLE ELEC. SCHEMATIC SLV, SOFT START



MATERIAL SAFETY DATA SHEET

PURE GOOP™

November 2003

1. PRODUCT IDENTIFICATION

PURE GOOP: Thread lubricant

Manufactured by:
Swagelok Company
29500 Solon Road
Solon, Ohio USA 44139
Tel: (440) 248-4600
Fax: (440) 349-5970

Emergency Contact:
Chemtrec (800) 424-9300

2. INGREDIENTS

Ingredients	CAS #	WT%	PEL
Polychlorotrifluoroethylene	9002-83-9	75-85	Not Available
Polytetrafluoroethylene	9002-84-0	15-20	Not Available
Amorphous Silica	7631-86-9	1-5	Not Available

3. HEALTH HAZARD INFORMATION

- European Community Danger Group:..... None
- Special Hazards for man or environment: None
- LD₅₀/LC₅₀ Not Available

Routes of Entry

Skin Contact	Skin Absorption	Eye Contact	Inhalation	Ingestion
No	No	Yes	Yes	Yes

4. FIRST AID MEASURES

- If inhaled (Overexposure): If person is affected by fumes, remove person to fresh air. Seek medical attention.
- After contact with skin (Overexposure): Wash thoroughly with soap and water. If severe irritation develops, seek medical attention.
- After contact with eyes: Rinse thoroughly with water for 15 minutes, seek medical attention. Do not rub eyes.
- If swallowed: Seek medical attention.
- Medical information: Unlikely to cause ill effects. Inhaling fumes of decomposition products can cause temporary influenza-like symptoms which are described as "polymer fume fever". Symptoms include fever, cough, and malaise.

5. FIRE FIGHTING MEASURES



MATERIAL SAFETY DATA SHEET

PURE GOOP™

November 2003

- Suitable extinguishing agents: Carbon dioxide, foam, agent suitable for environment.
- Not suitable for safety reasons: None known.
- Special dangers caused by substance preparation itself, by combustion products or gases formed: May decompose above 500°F/260°C to produce organo-chlorine compounds, organo-fluorine compounds, hydrogen fluoride, and chlorine gas.
- Additional information: None.

Auto ignition	UEL	LEL	Sensitivities
Not Applicable	Not Available	Not Available	Not Available

6. ACCIDENTAL RELEASE MEASURES

- Measures for protection of people: Put on necessary protective equipment. Eye and hand protection as needed.
- Measures for protection of the environment: None required.
- Cleaning measures: Use absorbent material and suitable cleaner.
- Additional information: None.

7. HANDLING AND STORAGE

- Safety information: None.
- Information on protection from fire: May decompose above 500°F/260°C to produce organo-chlorine compounds, organo-fluorine compounds, hydrogen fluoride, and chlorine gas.
- Additional information: Store in a cool, dry place for optimal product performance.

8. EXPOSURE CONTROLS AND PERSONAL PROTECTION

- Precautionary measures to protect employees: None required.
- Respiratory protection: None required.
- Hand protection: Rubber gloves are recommended to minimize exposure.
- Eye protection: Safety glasses or goggles are recommended to minimize exposure.
- Skin protection: Wash hands after use.



MATERIAL SAFETY DATA SHEET

PURE GOOP™

November 2003

9. PHYSICAL AND CHEMICAL PROPERTIES

Appearance Opaque-white	Odor Neutral	pH Not Applicable	Density 2.1 gm/cm ³	Vapor Pressure <0.01mm Hg
Boiling Point Not Available	Melting Point Not Available	Flash Point Not Available	Flammability Not Available	Explosive Not Applicable

10. STABILITY AND REACTIVITY

- Conditions to avoid: May decompose above 500°F/260°C to produce organo-chlorine or compounds, organo-fluorine compounds, hydrogen fluoride, and chlorine gas.
- Materials to avoid: Sodium, potassium, barium, calcium, finely divided zinc, aluminum, magnesium, and beryllium. Avoid aluminum-threaded connections where galling and seizure may initiate a reaction. Reacts with amines, liquid fluorine, and liquid chlorine trifluoride.
- Hazardous decomposition products: See Sections 4 and 5.

11. TOXICOLOGICAL INFORMATION

- Acute toxic properties: None known.
- Health effects: See Sections 4 and 5.
- Additional health effects: None known.

Sensitization	Teratogenicity	Reproductive Toxicity	Mutagenicity	Synergistic Products	Carcinogenicity
Not Available	Not Available	Not Available	Not Available	Not Available	Listed ingredients are not suspected carcinogens according to NTP, and IARC

12. ECOLOGICAL INFORMATION

- Mobility: Paste-like viscosity.
- Degradability: Not established.
- Accumulation: No known adverse bioaccumulation or biomagnification effects.
- Short / Long term effects on ecotoxicity: No known ecological effects.



MATERIAL SAFETY DATA SHEET

PURE GOOP™

November 2003

13. DISPOSAL CONSIDERATIONS

- Appropriate methods of disposal: Unused product not considered a hazardous waste in the United States. Dispose of in a responsible manner.
- European Community(EC) considerations: Use appropriate waste codes based on ingredients.

14. TRANSPORT INFORMATION

- Transport precautions: Consult applicable regulations when transporting this product
- Additional information: None.

15. REGULATORY INFORMATION

- EC regulations: This product has been classified under CHIP-96 guidelines based on chemical content.
- US/Canadian regulation listings: SARA 313 - NO, TSCA - YES, Canada's Controlled Products - NO
- EC Relevant risk: None.
- EC Relevant safety: S: 37/39 - Wear suitable gloves and eye/face protection.
S:20 - When using do not eat or drink.
- Additional information: Consult country codes for specific requirements.

16. OTHER INFORMATION

- Further information contact: Your Swagelok Distributor or the contacts listed in Section 1 of this sheet.
- Sources of information used to compile document: Properties of individual ingredients were used to compile this document. This Material Safety Data Sheet was designed to give the distributors and users of PURE GOOP information to handle and use the product in a responsible manner.

Preparation Data		
Environmental and Safety Department	(440) 349-5955	November 2003

Revision Date: 12/10/2004

Issue date: 12/13/2004

1. CHEMICAL PRODUCT AND COMPANY IDENTIFICATION

Product name: Loctite(R) 222 Threadlocker Low Strength
Product Use: Sealant
Company address:
Henkel Canada, Inc.
2255 Meadowpine Boulevard
Mississauga, Ontario L5N 7P2

Item No. : 21464
Region: Canada
Contact Information:
Telephone: 905.814.6511
Emergency telephone: 905.814.6511
Internet: www.loctite.com

2. COMPOSITION/INFORMATION ON INGREDIENTS

<u>Hazardous components</u>	<u>%</u>	<u>ACGIH TLV</u>	<u>OSHA PEL</u>	<u>OTHER</u>
Polyglycol dimethacrylate 25852-47-5	30-60	None	None	None
Polyglycol oleate 9004-96-0	30-60	None	None	None
Silica, amorphous, treated 68909-20-6	5-10	10 mg/m ³ (Inhal)	20mppcf	6 mg/m ³
Saccharin 81-07-2	1-5	None	None	None
Propylene glycol 57-55-6	1-5	None	None	None
Cumene hydroperoxide 80-15-9	1-5	None	None	1 ppm (6 mg/m ³) Skin (WEEL)

3. HAZARDS IDENTIFICATION**EMERGENCY OVERVIEW**

Physical state: Liquid
Color: Purple
Odor: Mild
WHMIS hazard class: D.2.B

WARNING: CAUSES EYE IRRITATION.
MAY CAUSE ALLERGIC SKIN REACTION.
MAY CAUSE SKIN IRRITATION.
MAY CAUSE RESPIRATORY TRACT IRRITATION.

Relevant routes of exposure: Skin, Inhalation, Eyes

Potential Health Effects

Inhalation: May cause respiratory tract irritation.
Skin contact: May cause allergic skin reaction. May cause skin irritation.
Eye contact: Contact with eyes will cause irritation.
Ingestion: Not expected to be harmful by ingestion.

Existing conditions aggravated by exposure: Eye, skin, and respiratory disorders.

See Section 11 for additional toxicological information.

Item No. : 21464

Product name: Loctite(R) 222 Threadlocker Low Strength

4. FIRST AID MEASURES

Inhalation:	Remove to fresh air. If symptoms develop and persist, get medical attention.
Skin contact:	Wash with soap and water. Remove contaminated clothing and shoes. Wash clothing before reuse. Get medical attention if symptoms occur.
Eye contact:	Flush with copious amounts of water, preferably, lukewarm water for at least 15 minutes, holding eyelids open all the time. Get medical attention.
Ingestion:	Do not induce vomiting. Keep individual calm. Obtain medical attention.

5. FIRE-FIGHTING MEASURES

Flash point:	Greater than 93°C (200°F) Tagliabue closed cup
Autoignition temperature:	Not available
Flammable/Explosive limits-lower %:	Not available
Flammable/Explosive limits-upper %:	Not available
Extinguishing media:	Foam, dry chemical or carbon dioxide.
Special fire fighting procedures:	Wear self-contained breathing apparatus and full protective clothing, such as turn-out gear.
Unusual fire or explosion hazards:	None
Hazardous combustion products:	Oxides of carbon. Oxides of sulfur. Oxides of nitrogen. Irritating organic vapors.
Sensitivity to mechanical impact:	Not available.
Sensitivity to static discharge:	Not available.

6. ACCIDENTAL RELEASE MEASURES

Environmental precautions:	Prevent product from entering drains or open waters.
Clean-up methods:	Soak up with inert absorbent. Store in a partly filled, closed container until disposal.

7. HANDLING AND STORAGE

Handling:	Avoid contact with eyes, skin and clothing. Avoid breathing vapor and mist. Wash thoroughly after handling. Use only with adequate ventilation.
Storage:	For safe storage, store at or below 38°C (100°F). Keep in a cool, well ventilated area away from heat, sparks and open flame. Keep container tightly closed until ready for use.
Incompatible products:	Refer to Section 10.

For information on product shelf life contact Loctite Canada Customer Service at (905) 814-6511.

8. EXPOSURE CONTROLS / PERSONAL PROTECTION

Engineering controls:	No specific ventilation requirements noted, but forced ventilation may still be required if concentrations exceed occupational exposure limits.
Respiratory protection:	Use NIOSH approved respirator if there is potential to exceed exposure limit(s).

Item No. : 21464

Product name: Loctite(R) 222 Threadlocker Low Strength

Skin protection: Use impermeable gloves and protective clothing as necessary to prevent skin contact. Neoprene gloves. Butyl rubber gloves. Natural rubber gloves.

Eye/face protection: Safety goggles or safety glasses with side shields.

See Section 2 for exposure limits.

9. PHYSICAL AND CHEMICAL PROPERTIES

Physical state: Liquid
Color: Purple
Odor: Mild
Odor Threshold: Not available
Vapor pressure: Less than 5 mm Hg at 27°C (80°F)
pH: Not applicable
Boiling point/range: Greater than 149°C (300°F)
Melting point/range: Not available
Specific gravity: 1.08 at 20°C (68°F)
Vapor density: Not available
Evaporation rate: Not available
Solubility in water: Slight
Partition coefficient (n-octanol/water): Not available
VOC content: 11.8%; 127 grams/liter (EPA Method 24)

10. STABILITY AND REACTIVITY

Stability: Stable.

Hazardous polymerization: Will not occur.

Hazardous decomposition products: Oxides of carbon. Oxides of sulfur. Oxides of nitrogen. Irritating organic vapors.

Incompatibility: Strong oxidizers.

Conditions to avoid: See "Handling and Storage" (Section 7) and "Incompatibility" (Section 10).

11. TOXICOLOGICAL INFORMATION

Product toxicity data: Acute oral LD50 greater than 10,000 mg/kg (rat). Acute dermal LD50 greater than 5000 mg/kg (rabbit).

Toxicologically synergistic products: Not available.

Refer to the following for Irritancy of Product, Sensitization to Product, Carcinogenicity, Reproductive Toxicity, Teratogenicity, and Mutagenicity.

Ingredient Toxicity Data & Carcinogen Status

Hazardous components	LD50s & LC50s (NIOSH) :	Other LD50s and LC50s:	NTP Carcinogen	IARC Carcinogen	OSHA Carcinogen	ACGIH - Carcinogens
Polyglycol dimethacrylate 25852-47-5	None	None	No	No	No	No
Polyglycol oleate 9004-96-0	Oral LD50 (Mouse) > 25 g/kg	None	No	No	No	No
Silica, amorphous, treated 68909-20-6	None	None	No	No	No	No
Saccharin 81-07-2	Oral LD50 (Mouse) = 17 g/kg	None	No	No	No	No

Item No. : 21464

3 of 5

Product name: Loctite(R) 222 Threadlocker Low Strength

Propylene glycol 57-55-6	Oral LD50 (Rat) = 20 g/kg Dermal LD50 (Rabbit) = 20800 mg/kg Oral LD50 (Mouse) = 22 g/kg	None	No	No	No	No
Cumene hydroperoxide 80-15-9	Inhalation LC50 (Mouse) = 200 ppm Inhalation LC50 (Rat) = 220 ppm Oral LD50 (Rat) = 382 mg/kg	None	No	No	No	No

Literature Referenced Target Organ & Other Health Effects

Hazardous components	Health Effects/Target Organs
Polyglycol dimethacrylate 25852-47-5	Allergen, Irritant
Polyglycol oleate 9004-96-0	Irritant
Silica, amorphous, treated 68909-20-6	No Target Organs
Saccharin 81-07-2	No Target Organs
Propylene glycol 57-55-6	Irritant
Cumene hydroperoxide 80-15-9	Allergen, Central nervous system, Corrosive, Irritant, Mutagen

12. ECOLOGICAL INFORMATION

Ecological information: Not available

13. DISPOSAL CONSIDERATIONS

Information provided is for unused product only.

Recommended method of disposal: Dispose of in accordance with federal and local regulations.

14. TRANSPORT INFORMATION

Canada Transportation of Dangerous Goods - Ground:

Proper shipping name: Unrestricted
Hazard class or division: None
Identification number: None
Packing group: None

International Air Transportation (ICAO/IATA):

Proper shipping name: Unrestricted
Hazard class or division: None
Identification number: None
Packing group: None

WaterTransportation (IMO/IMDG):

Proper shipping name: Unrestricted
Hazard class or division: None
Identification number: None
Packing group: None
Marine pollutant: None

Item No. : 21464

Product name: Loctite(R) 222 Threadlocker Low Strength

15. REGULATORY INFORMATION

Canada Regulatory Information

CEPA DSL/NDSL Status: All components are listed on or are exempt from listing on the Domestic Substances List.

United States Regulatory Information

TSCA 8 (b) Inventory Status: All components are listed or are exempt from listing on the Toxic Substances Control Act Inventory.

16. OTHER INFORMATION

This material safety data sheet contains changes from the previous version in sections: New Material Safety Data Sheet format.

This product has been classified in accordance with the hazard criteria of the Controlled Products Regulations and the MSDS contains all the information required by the Controlled Product Regulations.

Prepared by: Kyra Kozak Woods, Health and Regulatory Affairs Specialist

DISCLAIMER: The data contained herein are furnished for information only and are believed to be reliable. However, Henkel Corporation does not assume responsibility for any results obtained by persons over whose methods Henkel Corporation has no control. It is the user's responsibility to determine the suitability of Henkel's products or any production methods mentioned herein for a particular purpose, and to adopt such precautions as may be advisable for the protection of property and persons against any hazards that may be involved in the handling and use of any of Henkel Corporation's products. In light of the foregoing, Henkel Corporation specifically disclaims all warranties, express or implied, including warranties of merchantability and fitness for a particular purpose, arising from sale or use of Henkel Corporation's products. Henkel Corporation further disclaims any liability for consequential or incidental damages of any kind, including lost profits.

JL-M MATERIAL SAFETY DATA SHEET

SECTION 1 – PRODUCT IDENTIFICATION				
Product Name: JL-M Lubricant Revised: 03/07/03 Supercedes: 03/17/00 Prepared by: C. Semerod Emergency Information: (412) 279-1149	Manufacturer's Name: Superbolt, Inc. Manufacturer's Address: 1000 Gregg Street Carnegie, PA 15106 Manufacturer's Phone #: (412) 279-1149			
SECTION 2 – HAZARDOUS INGREDIENTS				
CHEMICAL NAME:	CAS NO.:	OSHA PEL:	ACGIH TLV:	(STEL)
Molybdenum Disulfide	1317-33-5	10 mg/m3	10 mg/m3	N/A
Silica, Fused	60676-86-0	0.1 mg/m3	0.1 mg/m3	N/A
Graphite	7782-42-5		2 mg/m3	N/A
Silica, Crystalline	14808-60-7		0.1 mg/m3	N/A
Lubricating Oils, Petroleum, Hydrotreated, Spent	64742-58-1	5 mg/m3*	5 mg/m3*	10mg/m3*
Residual Oils (Petroleum), Solvent Dewaxed	64742-62-7	5 mg/m3*	5 mg/m3*	10 mg/m3*
Solvent-Refined Heavy Paraffinic Distillate (Petroleum)	64741-88-4	5 mg/m3*	5 mg/m3*	10 mg/m3*
Solvent –Dewaxed Hydrotreated Heavy Paraffinic Distillate (Petroleum)	64742-65-0	5 mg/m3*	5 mg/m3*	10 mg/m3*
Hydrotreated Heavy Paraffinic Distillate (Petroleum)	64742-54-7	5 mg/m3*	5 mg/m3*	10 mg/m3*
Proprietary Additives Mixture (<1%)				
(*) Designates limits set by OSHA and the ACGIH for oil mist. This product is sold in a paste form so misting should not occur.				
SECTION 3 – PHYSICAL DATA		SECTION 4 – FIRE AND EXPLOSION DATA		
Appearance and Odor: Dark Grey Paste, Mild Petroleum Boiling Point: > 500 degrees F % Volatile: 0% Vapor Density: > 1 (Air = 1) Evaporation Rate: < 1 (Ether = 1) Specific Gravity: 4.8 (Water = 1) Vapor Pressure: Essentially 0 (mm Hg) Solubility in Water: Insoluble pH: N/A		Flash Point: 338 degrees F Lower Explosive Limit: N/A Upper Explosive Limit: N/A Extinguishing Media: Carbon Dioxide, Regular Foam, Dry Chemical Special Fire Fighting Procedures: Fire may produce dense smoke, firefighters should wear self contained breathing apparatus. Use water to cool fire exposed containers. Unusual Fire & Explosion Hazards: Decomposition and combustion by-products may be toxic. Heated containers may rupture or explode.		
SECTION 5 – REACTIVITY DATA		SECTION 6 – STORAGE & HANDLING		
Stability: Stable Hazardous Polymerization: Will not occur. Incompatibility: Avoid contact with oxidizing agents, heat, sparks or flame. Hazardous Combustion By-Products: Carbon Monoxide, Sulfur Dioxide, Aldehydes, and Nitrogen Oxides Hazardous Decomposition: Thermal decomposition may yield methacrylate monomers.		Handling Precautions: Use good personal hygiene practices. Clean contaminated clothing and protective equipment before reuse. Storage Precautions: Store in a cool dry location. Keep container tightly closed when not in use and during transport. Keep away from open sparks or flames.		
SECTION 7 – HEALTH HAZARDS				
Effects of Overexposure: Skin: May Cause Irritation Eyes: Eye Irritant. May cause redness and Blurred vision. Ingestion: Not Expected Inhalation: Not Expected (Chronic respiratory diseases may be aggravated by dust exposure.) NFPA CODES: Health: 1 Flammability: 1 Reactivity: 0 Carcinogenicity: Silica is a suspected carcinogen in a respirable form by the IARC and NTP however, not by the ACIGH or OSHA.		First Aid Procedures: Skin: Remove contaminated clothing from irritated area. Flush exposed area with mild soap and water. Seek medical attention if irritation persists. Eyes: Flush eyes with large quantities of water, holding eyelids open. Seek medical attention if irritation persists. Ingestion: Do not induce vomiting. If spontaneous vomiting occurs, keep head below hips to avoid aspiration into the lungs. Seek immediate medical attention. Inhalation: Remove to fresh air. Obtain medical attention if necessary.		
SECTION 8 – SPECIAL PROTECTION		SECTION 9 – SPILL AND DISPOSAL PROCEDURES		
Eye Protection: Safety Glasses or Face Shield Protective Gloves: Recommended Respiratory Protection: Avoid breathing dust, use an approved respirator if levels exceed OSHA limits. Ventilation: Local ventilation to maintain levels within OSHA limits.		Spill Procedures: Scrape or wipe up any spilled material. Wear proper protective equipment when cleaning up a spill. Disposal Procedures: Dispose of in accordance with any applicable federal, state, or local laws.		

The information in this MSDS was obtained from sources which we believe are reliable. However, the information is provided without any representation or warranty, expressed or implied, regarding the accuracy or correctness. The conditions or methods of handling, storage, use and disposal of the product are beyond our control. For this and other reasons, we do not assume responsibility and expressly disclaim liability for loss, damage, or expense arising out of or in any way connected with the handling, storage, use or disposal of the product.



LUBRIPLATE®

MATERIAL SAFETY DATA SHEET

Section 1

PRODUCT NAME OR NUMBER:

LUBRIPLATE Super FML-0, FML-1, FML-2

FORMULA:

Calcium Soap, USP Mineral Oil and Additives

GENERIC/CHEMICAL NAME:

Petroleum Lubricating Grease

NSF Registration No's:

125742, 125740, 125741

Manufacturer's Name:

Fiske Brothers Refining Co.

Emergency Telephone Number:

1-800-255-3924 - CHEM-TEL (24 hour)

Address:

1500 Oakdale Ave., Toledo, Ohio 43605 - 129 Lockwood St., Newark, NJ 07105

Telephone Number for Information:

419-691-2491 - Toledo Office

Section 2 - Hazardous Ingredients/Identity Information

<u>Hazardous Components</u>	<u>OSHA PEL</u>	<u>ACGIH TLV</u>	<u>Other Limits Recommended</u>	<u>% (optional)</u>
-----------------------------	-----------------	------------------	---------------------------------	---------------------

Non-hazardous

Hazardous Material Identification System (HMIS): Health - 1, Flammability - 1, Reactivity - 0**Not a Controlled Product under (WHMIS) - Canada****Special Protection: See Section 9**

Section 3 - Health Hazard Data

Threshold Limit Value: 5 mg/m³ for oil mist in air. OSHA Regulation 29 CFR 1910.1000**Effects of Overexposure:** Prolonged or repeated skin contact may cause skin irritation. Product contacting the eyes may cause eye irritation. Human health risks vary from person to person. As a precaution, exposure to liquids, vapors, mists and fumes should be minimized. This product has a low order of acute oral toxicity, but minute amounts aspirated into the lungs during ingestion may cause mild to severe pulmonary injury.**Carcinogenicity:** NTP? No IARC Monographs? No OSHA Regulated? No

Section 4 - Emergency and First Aid Procedures

EYE CONTACT: Flush with clear water for 15 minutes or until irritation subsides. If irritation persists, consult a physician.**SKIN CONTACT:** Remove any contaminated clothing and wash with soap and warm water. If injected by high pressure under skin, regardless of the appearance or its size, contact a physician IMMEDIATELY. Delay may cause loss of affected part of the body.**INHALATION:** Vapor pressure is very low and inhalation at room temperature is not a problem. If overcome by vapor from hot product, immediately remove from exposure and call a physician.**INGESTION:** If ingested, call a physician immediately. Do not induce vomiting.

Section 5 - Fire and Explosion Hazard Data

Flash Point (Method Used): COC - 435°F **Flammable Limits:** LEL 0.9% UEL 7.0%**Extinguishing Media:** Foam, Dry Chemical, Carbon Dioxide or Water Spray (Fog)**Special Fire Fighting Procedures:** Cool exposed containers with water. Use air-supplied breathing equipment for enclosed or confined spaces.**Unusual Fire and Explosion Hazards:** Do not store or mix with strong oxidants. Empty containers retain residue. Do not cut, drill, grind, or weld, as they may explode.

Section 6 - Physical/Chemical Characteristics

Boiling Point:	>550°F	Specific Gravity (H₂O = 1):	0.90 - 0.91
Vapor Pressure (mm Hg.):	<0.01	Melting Point:	Semi-solid
Vapor Density (AIR = 1):	>5	Evaporation Rate: (Butyl Acetate = 1)	<0.01
Solubility in Water:	Negligible		
Appearance and Odor:	Smooth, white grease with mineral oil odor.		

Section 7 - Reactivity Data

Stability:	Unstable Stable X	Conditions to Avoid:	N/A
Incompatibility (Materials to Avoid):	Avoid contact with strong oxidants like liquid chlorine, concentrated oxygen.		
Hazardous Decomposition or Byproducts:	May form SO ₂ . If incomplete combustion, Carbon Monoxide.		
Hazardous Polymerization:	May Occur Will Not Occur X	Conditions to Avoid:	N/A

Section 8 - Spill or Leak Procedures

Steps to be taken in case material is released or spilled:

Scrape up grease, wash remainder with suitable petroleum solvent or add absorbent. Keep petroleum products out of sewers and watercourses. Advise authorities if product has entered or may enter sewers and watercourses.

Waste disposal method:

Assure conformity with applicable disposal regulations. Dispose of absorbed material at an approved waste disposal facility or site.

SARA/TITLE III, Section 313 Status - Zinc Compounds - <6%

Section 9 - Special Protection Information

Respiratory Protection (Specify type):	Normally not needed		
Ventilation	Local Exhaust:	Used to capture fumes and vapors	Special: N/A
	Mechanical (General)		Other: N/A
Protective Gloves:	Use oil-resistant gloves, if needed.	Eye Protection:	If chance of eye contact, wear goggles.
Other Protective Equipment:	Use oil-resistant apron, if needed.		

Section 10 - Special Precautions

Precautions to be taken in handling and storing:

Keep containers closed when not in use. Do not handle or store near heat, sparks, flame, or strong oxidants.

Other Precautions:

Remove oil-soaked clothing and laundry before reuse. Cleanse skin thoroughly after contact.

The above information is furnished without warranty, expressed or implied, except that it is accurate to the best knowledge of Fiske Brothers Refining Company. The data on these sheets relates only to the specific material designated herein. Fiske Brothers Refining Company assumes no legal responsibility for use or reliance upon this data.

MATERIAL SAFETY DATA SHEET

SECTION 1 PRODUCT AND COMPANY IDENTIFICATION

PRODUCT

Product Name: MOBIL DTE 26
Product Description: Base Oil and Additives
Product Code: 201560102030, 602649-00, 970101
Intended Use: Hydraulic fluid

COMPANY IDENTIFICATION

Supplier: EXXON MOBIL CORPORATION
3225 GALLOWS RD.
FAIRFAX, VA. 22037 USA

24 Hour Health Emergency 609-737-4411
Transportation Emergency Phone 800-424-9300
ExxonMobil Transportation No. 281-834-3296
MSDS Requests 713-613-3661
Product Technical Information 800-662-4525, 800-947-9147
MSDS Internet Address <http://www.exxon.com>, <http://www.mobil.com>

SECTION 2 COMPOSITION / INFORMATION ON INGREDIENTS

No Reportable Hazardous Substance(s) or Complex Substance(s).

SECTION 3 HAZARDS IDENTIFICATION

This material is not considered to be hazardous according to regulatory guidelines (see (M)SDS Section 15).

POTENTIAL HEALTH EFFECTS

Low order of toxicity. Excessive exposure may result in eye, skin, or respiratory irritation. High-pressure injection under skin may cause serious damage.

NFPA Hazard ID:	Health: 0	Flammability: 1	Reactivity: 0
HMIS Hazard ID:	Health: 0	Flammability: 1	Reactivity: 0

NOTE: This material should not be used for any other purpose than the intended use in Section 1 without expert advice. Health studies have shown that chemical exposure may cause potential human health risks which may vary from person to person.

SECTION 4 FIRST AID MEASURES

INHALATION

Remove from further exposure. For those providing assistance, avoid exposure to yourself or others. Use adequate respiratory protection. If respiratory irritation, dizziness, nausea, or unconsciousness occurs, seek immediate medical assistance. If breathing has stopped, assist ventilation with a mechanical device or use

Product Name: MOBIL DTE 26

Revision Date: 14Apr2008

Page 2 of 8

mouth-to-mouth resuscitation.

SKIN CONTACT

Wash contact areas with soap and water. If product is injected into or under the skin, or into any part of the body, regardless of the appearance of the wound or its size, the individual should be evaluated immediately by a physician as a surgical emergency. Even though initial symptoms from high pressure injection may be minimal or absent, early surgical treatment within the first few hours may significantly reduce the ultimate extent of injury.

EYE CONTACT

Flush thoroughly with water. If irritation occurs, get medical assistance.

INGESTION

First aid is normally not required. Seek medical attention if discomfort occurs.

SECTION 5

FIRE FIGHTING MEASURES

EXTINGUISHING MEDIA

Appropriate Extinguishing Media: Use water fog, foam, dry chemical or carbon dioxide (CO₂) to extinguish flames.

Inappropriate Extinguishing Media: Straight Streams of Water

FIRE FIGHTING

Fire Fighting Instructions: Evacuate area. Prevent runoff from fire control or dilution from entering streams, sewers, or drinking water supply. Firefighters should use standard protective equipment and in enclosed spaces, self-contained breathing apparatus (SCBA). Use water spray to cool fire exposed surfaces and to protect personnel.

Unusual Fire Hazards: Pressurized mists may form a flammable mixture.

Hazardous Combustion Products: Aldehydes, Smoke, Fume, Sulfur oxides, Incomplete combustion products, Oxides of carbon

FLAMMABILITY PROPERTIES

Flash Point [Method]: >204C (399F) [ASTM D-92]

Flammable Limits (Approximate volume % in air): LEL: 0.9 UEL: 7.0

Autoignition Temperature: N/D

SECTION 6

ACCIDENTAL RELEASE MEASURES

NOTIFICATION PROCEDURES

In the event of a spill or accidental release, notify relevant authorities in accordance with all applicable regulations. In the event of a spill or accidental release, notify relevant authorities in accordance with all applicable regulations. US regulations require reporting releases of this material to the environment which exceed the applicable reportable quantity or oil spills which could reach any waterway including intermittent dry creeks. The National Response Center can be reached at (800)424-8802.

Product Name: MOBIL DTE 26

Revision Date: 14Apr2008

Page 3 of 8

SPILL MANAGEMENT

Land Spill: Stop leak if you can do it without risk. Recover by pumping or with suitable absorbent.

Water Spill: Stop leak if you can do it without risk. Confine the spill immediately with booms. Warn other shipping. Remove from the surface by skimming or with suitable absorbents. Seek the advice of a specialist before using dispersants.

Water spill and land spill recommendations are based on the most likely spill scenario for this material; however, geographic conditions, wind, temperature, (and in the case of a water spill) wave and current direction and speed may greatly influence the appropriate action to be taken. For this reason, local experts should be consulted. Note: Local regulations may prescribe or limit action to be taken.

ENVIRONMENTAL PRECAUTIONS

Large Spills: Dike far ahead of liquid spill for later recovery and disposal. Prevent entry into waterways, sewers, basements or confined areas.

SECTION 7

HANDLING AND STORAGE

HANDLING

Prevent small spills and leakage to avoid slip hazard.

Static Accumulator: This material is a static accumulator.

STORAGE

Do not store in open or unlabelled containers.

SECTION 8

EXPOSURE CONTROLS / PERSONAL PROTECTION

Exposure limits/standards for materials that can be formed when handling this product: When mists / aerosols can occur, the following are recommended: 5 mg/m³ - ACGIH TLV, 10 mg/m³ - ACGIH STEL, 5 mg/m³ - OSHA PEL.

NOTE: Limits/standards shown for guidance only. Follow applicable regulations.

ENGINEERING CONTROLS

The level of protection and types of controls necessary will vary depending upon potential exposure conditions. Control measures to consider:

No special requirements under ordinary conditions of use and with adequate ventilation.

PERSONAL PROTECTION

Personal protective equipment selections vary based on potential exposure conditions such as applications, handling practices, concentration and ventilation. Information on the selection of protective equipment for use with this material, as provided below, is based upon intended, normal usage.

Product Name: MOBIL DTE 26

Revision Date: 14Apr2008

Page 4 of 8

Respiratory Protection: If engineering controls do not maintain airborne contaminant concentrations at a level which is adequate to protect worker health, an approved respirator may be appropriate. Respirator selection, use, and maintenance must be in accordance with regulatory requirements, if applicable. Types of respirators to be considered for this material include:

No special requirements under ordinary conditions of use and with adequate ventilation.

For high airborne concentrations, use an approved supplied-air respirator, operated in positive pressure mode. Supplied air respirators with an escape bottle may be appropriate when oxygen levels are inadequate, gas/vapor warning properties are poor, or if air purifying filter capacity/rating may be exceeded.

Hand Protection: Any specific glove information provided is based on published literature and glove manufacturer data. Glove suitability and breakthrough time will differ depending on the specific use conditions. Contact the glove manufacturer for specific advice on glove selection and breakthrough times for your use conditions. Inspect and replace worn or damaged gloves. The types of gloves to be considered for this material include:

No protection is ordinarily required under normal conditions of use.

Eye Protection: If contact is likely, safety glasses with side shields are recommended.

Skin and Body Protection: Any specific clothing information provided is based on published literature or manufacturer data. The types of clothing to be considered for this material include:

No skin protection is ordinarily required under normal conditions of use. In accordance with good industrial hygiene practices, precautions should be taken to avoid skin contact.

Specific Hygiene Measures: Always observe good personal hygiene measures, such as washing after handling the material and before eating, drinking, and/or smoking. Routinely wash work clothing and protective equipment to remove contaminants. Discard contaminated clothing and footwear that cannot be cleaned. Practice good housekeeping.

ENVIRONMENTAL CONTROLS

See Sections 6, 7, 12, 13.

SECTION 9

PHYSICAL AND CHEMICAL PROPERTIES

Typical physical and chemical properties are given below. Consult the Supplier in Section 1 for additional data.

GENERAL INFORMATION

Physical State: Liquid

Color: Brown

Odor: Characteristic

Odor Threshold: N/D

IMPORTANT HEALTH, SAFETY, AND ENVIRONMENTAL INFORMATION

Relative Density (at 15 C): 0.881

Flash Point [Method]: >204C (399F) [ASTM D-92]

Flammable Limits (Approximate volume % in air): LEL: 0.9 UEL: 7.0

Autoignition Temperature: N/D

Boiling Point / Range: > 316C (600F)

Vapor Density (Air = 1): > 2 at 101 kPa

Product Name: MOBIL DTE 26

Revision Date: 14Apr2008

Page 5 of 8

Vapor Pressure: < 0.013 kPa (0.1 mm Hg) at 20 C

Evaporation Rate (n-butyl acetate = 1): N/D

pH: N/A

Log Pow (n-Octanol/Water Partition Coefficient): > 3.5

Solubility in Water: Negligible

Viscosity: 71.2 cSt (71.2 mm²/sec) at 40 C | 8.5 cSt (8.5 mm²/sec) at 100C

Oxidizing Properties: See Sections 3, 15, 16.

OTHER INFORMATION

Freezing Point: N/D

Melting Point: N/A

Pour Point: -18°C (0°F)

DMSO Extract (mineral oil only), IP-346: < 3 %wt

SECTION 10	STABILITY AND REACTIVITY
-------------------	---------------------------------

STABILITY: Material is stable under normal conditions.

CONDITIONS TO AVOID: Excessive heat. High energy sources of ignition.

MATERIALS TO AVOID: Strong oxidizers

HAZARDOUS DECOMPOSITION PRODUCTS: Material does not decompose at ambient temperatures.

HAZARDOUS POLYMERIZATION: Will not occur.

SECTION 11	TOXICOLOGICAL INFORMATION
-------------------	----------------------------------

ACUTE TOXICITY

Route of Exposure	Conclusion / Remarks
Inhalation	
Toxicity (Rat): LC50 > 5000 mg/m ³	Minimally Toxic. Based on assessment of the components.
Irritation: No end point data.	Negligible hazard at ambient/normal handling temperatures. Based on assessment of the components.
Ingestion	
Toxicity (Rat): LD50 > 2000 mg/kg	Minimally Toxic. Based on test data for structurally similar materials.
Skin	
Toxicity (Rabbit): LD50 > 2000 mg/kg	Minimally Toxic. Based on test data for structurally similar materials.
Irritation (Rabbit): Data available.	Negligible irritation to skin at ambient temperatures. Based on assessment of the components.
Eye	
Irritation (Rabbit): Data available.	May cause mild, short-lasting discomfort to eyes. Based on assessment of the components.

CHRONIC/OTHER EFFECTS

Contains:

Base oil severely refined: Not carcinogenic in animal studies. Representative material passes IP-346, Modified Ames test, and/or other screening tests. Dermal and inhalation studies showed minimal effects; lung non-

Product Name: MOBIL DTE 26

Revision Date: 14Apr2008

Page 6 of 8

specific infiltration of immune cells, oil deposition and minimal granuloma formation. Not sensitizing in test animals.

Additional information is available by request.

The following ingredients are cited on the lists below: None.

--REGULATORY LISTS SEARCHED--

1 = NTP CARC

3 = IARC 1

5 = IARC 2B

2 = NTP SUS

4 = IARC 2A

6 = OSHA CARC

SECTION 12

ECOLOGICAL INFORMATION

The information given is based on data available for the material, the components of the material, and similar materials.

ECOTOXICITY

Material -- Not expected to be harmful to aquatic organisms.

MOBILITY

Base oil component -- Low solubility and floats and is expected to migrate from water to the land. Expected to partition to sediment and wastewater solids.

PERSISTENCE AND DEGRADABILITY

Biodegradation:

Base oil component -- Expected to be inherently biodegradable

BIOACCUMULATION POTENTIAL

Base oil component -- Has the potential to bioaccumulate, however metabolism or physical properties may reduce the bioconcentration or limit bioavailability.

SECTION 13

DISPOSAL CONSIDERATIONS

Disposal recommendations based on material as supplied. Disposal must be in accordance with current applicable laws and regulations, and material characteristics at time of disposal.

DISPOSAL RECOMMENDATIONS

Product is suitable for burning in an enclosed controlled burner for fuel value or disposal by supervised incineration at very high temperatures to prevent formation of undesirable combustion products.

REGULATORY DISPOSAL INFORMATION

RCRA Information: The unused product, in our opinion, is not specifically listed by the EPA as a hazardous waste (40 CFR, Part 261D), nor is it formulated to contain materials which are listed as hazardous wastes. It does not exhibit the hazardous characteristics of ignitability, corrosivity or reactivity and is not formulated with contaminants as determined by the Toxicity Characteristic Leaching Procedure (TCLP). However, used product may be regulated.

Product Name: MOBIL DTE 26
 Revision Date: 14Apr2008
 Page 7 of 8

Empty Container Warning Empty Container Warning (where applicable): Empty containers may contain residue and can be dangerous. Do not attempt to refill or clean containers without proper instructions. Empty drums should be completely drained and safely stored until appropriately reconditioned or disposed. Empty containers should be taken for recycling, recovery, or disposal through suitably qualified or licensed contractor and in accordance with governmental regulations. DO NOT PRESSURISE, CUT, WELD, BRAZE, SOLDER, DRILL, GRIND, OR EXPOSE SUCH CONTAINERS TO HEAT, FLAME, SPARKS, STATIC ELECTRICITY, OR OTHER SOURCES OF IGNITION. THEY MAY EXPLODE AND CAUSE INJURY OR DEATH.

SECTION 14	TRANSPORT INFORMATION
-------------------	------------------------------

LAND (DOT) : Not Regulated for Land Transport

LAND (TDG) : Not Regulated for Land Transport

SEA (IMDG) : Not Regulated for Sea Transport according to IMDG-Code

AIR (IATA) : Not Regulated for Air Transport

SECTION 15	REGULATORY INFORMATION
-------------------	-------------------------------

OSHA HAZARD COMMUNICATION STANDARD: When used for its intended purposes, this material is not classified as hazardous in accordance with OSHA 29 CFR 1910.1200.

NATIONAL CHEMICAL INVENTORY LISTING: PICCS, TSCA, EINECS, IECSC, AICS, ENCS, KECI, DSL

EPCRA: This material contains no extremely hazardous substances.

SARA (311/312) REPORTABLE HAZARD CATEGORIES: None.

SARA (313) TOXIC RELEASE INVENTORY: This material contains no chemicals subject to the supplier notification requirements of the SARA 313 Toxic Release Program.

The Following Ingredients are Cited on the Lists Below:

Chemical Name	CAS Number	List Citations
ZINC ALKYL DITHIOPHOSPHATE	68649-42-3	15

--REGULATORY LISTS SEARCHED--

- | | | | |
|---------------|------------------|-------------------|-------------|
| 1 = ACGIH ALL | 6 = TSCA 5a2 | 11 = CA P65 REPRO | 16 = MN RTK |
| 2 = ACGIH A1 | 7 = TSCA 5e | 12 = CA RTK | 17 = NJ RTK |
| 3 = ACGIH A2 | 8 = TSCA 6 | 13 = IL RTK | 18 = PA RTK |
| 4 = OSHA Z | 9 = TSCA 12b | 14 = LA RTK | 19 = RI RTK |
| 5 = TSCA 4 | 10 = CA P65 CARC | 15 = MI 293 | |

Code key: CARC=Carcinogen; REPRO=Reproductive

SECTION 16	OTHER INFORMATION
-------------------	--------------------------

Product Name: MOBIL DTE 26

Revision Date: 14Apr2008

Page 8 of 8

N/D = Not determined, N/A = Not applicable

THIS SAFETY DATA SHEET CONTAINS THE FOLLOWING REVISIONS:

Revision Changes:

Section 06: Notification Procedures - Header was modified.

Section 13: Empty Container Warning was modified.

Section 08: Hand Protection was modified.

Section 15: List Citation Table - Header was modified.

Section 15: National Chemical Inventory Listing was modified.

Section 06: Notification Procedures was modified.

Section 15: TSCA Class 2 Statement was deleted.

The information and recommendations contained herein are, to the best of ExxonMobil's knowledge and belief, accurate and reliable as of the date issued. You can contact ExxonMobil to insure that this document is the most current available from ExxonMobil. The information and recommendations are offered for the user's consideration and examination. It is the user's responsibility to satisfy itself that the product is suitable for the intended use. If buyer repackages this product, it is the user's responsibility to insure proper health, safety and other necessary information is included with and/or on the container. Appropriate warnings and safe-handling procedures should be provided to handlers and users. Alteration of this document is strictly prohibited. Except to the extent required by law, republication or retransmission of this document, in whole or in part, is not permitted. The term, "ExxonMobil" is used for convenience, and may include any one or more of ExxonMobil Chemical Company, Exxon Mobil Corporation, or any affiliates in which they directly or indirectly hold any interest.

Internal Use Only

MHC: 0, 0, 0, 0, 0, 0

PPEC: A

DGN: 2007812XUS (546747)

Copyright 2002 Exxon Mobil Corporation, All rights reserved

Material Safety Data Sheet



HYDROCLEAR MULTIPURPOSE R&O OIL 32, 46, 68, 100, 150, 220, 320, 460

1. CHEMICAL PRODUCT/COMPANY IDENTIFICATION

HYDROCLEAR(R) MULTIPURPOSE R&O OIL

MSDS Code: HYDC0009 Revised: 29-July-2002

"HYDROCLEAR" is a registered trademark of Conoco.

ISO Grades: 32, 46, 68 100, 150, 220, 320, 460

Product Use: Industrial Oil

MANUFACTURER/DISTRIBUTOR

Conoco Inc.
PO Box 2197
Houston, TX 77252

PHONE NUMBERS

Product Information: 1-281-293-5550

Transport Emergency: CHEMTREC 1-800-424-9300 or
1-703-527-3887 (call collect)

Medical Emergency: 1-800-342-5119 or 1-281-293-5119

WEB SITE: www.conoco.com

2. COMPOSITION/INFORMATION ON INGREDIENTS

COMPONENTS	CAS NUMBER	%
Highly refined base oils	64742-54-7	0-99.5
Proprietary additives	64742-01-4	0-99.5
		<5

If oil mist is generated, exposure limits apply. See Section 8.

3. HAZARDS IDENTIFICATION

--- EMERGENCY OVERVIEW ---

APPEARANCE / ODOR

Clear and bright liquid / mild petroleum hydrocarbon odor.

OSHA REGULATORY STATUS

This material is classified as non-hazardous under OSHA Regulations.

HMIS RATING Health: 1; Flammability: 1; Physical Hazard: 0.

NFPA RATING Health: 1; Flammability: 1; Instability: 0.

Potential Health Effects

Primary Route of Entry: Skin

The product, as with many petroleum products, may cause minor skin,
 eye, and lung irritation, but good hygienic practices can minimize
 these effects.

Normal use of this product does not result in generation of an oil
 mist. However if an oil mist is generated, overexposure can cause
 minor and reversible irritation to the eyes, skin, and especially
 the lungs. Proper personal protective equipment and sufficient
 ventilation can provide adequate protection.

Carcinogenicity Information

None of the components present in this material at concentrations
 equal to or greater than 0.1% are listed by IARC, NTP, OSHA or ACGIH
 as a carcinogen.

4. FIRST AID MEASURES

Inhalation

If inhaled, remove to fresh air. If not breathing, give artificial
 respiration. If breathing is difficult, give oxygen. Call a
 physician.

Skin Contact

Wash skin thoroughly with soap and water. If irritation develops
 and persists, consult a physician.

If injected under the skin, necrosis could occur. See physician.

Eye Contact

In case of contact, immediately flush eyes with plenty of water for
 at least 15 minutes. Call a physician.

Ingestion

Material poses an aspiration hazard. If swallowed, do not induce
 vomiting. Immediately give 2 glasses of water. Never give anything
 by mouth to an unconscious person. Call a physician.

If vomiting occurs naturally, have victim lean forward to reduce the
 risk of aspiration.

Notes to Physicians

Activated charcoal mixture may be administered. To prepare activated
 charcoal mixture, suspend 50 grams activated charcoal in 400 mL water
 and mix thoroughly. Administer 5 mL/kg, or 350 mL for an average
 adult.

High velocity injection under the skin can cause a bloodless puncture
 wound and result in necrosis. Immediate attention by a surgical
 specialist is recommended.

5. FIRE FIGHTING MEASURES

Flammable Properties

Flash Point (minimum): 365 F (185 C) (Grade 32)
 374 F (190 C) (Grade 46)
 410 F (210 C) (Grade 68)
 428 F (220 C) (Grade 100)
 440 F (227 C) (Grade 150)

460 F (238 C) (Grade 220)
 490 F (254 C) (Grade 320)
 509 F (265 C) (Grade 460)

 Flash Point (typical): 450 F (232 C) (Grade 32)
 460 F (238 C) (Grade 46)
 470 F (243 C) (Grade 68)
 515 F (268 C) (Grade 100)
 530 F (277 C) (Grade 150)
 545 F (285 C) (Grade 220)
 580 F (304 C) (Grade 320)
 585 F (307 C) (Grade 460)

 Method: COC
 Autoignition: Not Available
 Flammable limits in Air, % by Volume
 LEL: Undetermined
 UEL: Undetermined

 Extinguishing Media
 Water Spray, Foam, Dry Chemical, CO2.

 Fire Fighting Instructions
 Water or foam may cause frothing. Use water to keep fire-exposed
 containers cool. Water may be used to flush spills away from
 exposures.

 Products of combustion may contain carbon monoxide, carbon dioxide,
 and other toxic materials. Do not enter enclosed or confined space
 without proper protective equipment including respiratory protection.

6. ACCIDENTAL RELEASE MEASURES

 Safeguards (Personnel)
 NOTE: Review FIRE FIGHTING MEASURES and HANDLING (PERSONNEL) sections
 before proceeding with clean-up. Use appropriate PERSONAL PROTECTIVE
 EQUIPMENT during clean-up.

 Remove source of heat, sparks, and flame.

 Initial Containment
 Dike spill. Prevent material from entering sewers, waterways, or
 low areas.

 Spill Clean Up
 Recover free liquid for reuse or reclamation. Soak up with sawdust,
 sand, oil dry or other absorbent material.

7. HANDLING AND STORAGE

 Handling (Personnel)
 Avoid breathing vapors or mist. Avoid contact with eyes. Avoid
 prolonged or repeated contact with skin. Wash thoroughly after
 handling. Wash contaminated clothing prior to reuse.

 Handling (Physical Aspects)
 Close container after each use. Do not pressurize, cut, weld, braze,
 solder, grind, or drill on or near full or empty container. Empty
 container retains residue (liquid and/or vapor) and may explode in

<input type="checkbox"/>	ISO 320	318	23.9	<input type="checkbox"/>
<input type="checkbox"/>	ISO 460	464	30.6	<input type="checkbox"/>

<input type="checkbox"/>	10. STABILITY AND REACTIVITY			<input type="checkbox"/>

<input type="checkbox"/>	Chemical Stability			<input type="checkbox"/>
<input type="checkbox"/>	Stable at normal temperatures and storage conditions.			<input type="checkbox"/>
<input type="checkbox"/>	Conditions to Avoid			<input type="checkbox"/>
<input type="checkbox"/>	Heat, sparks, and flames.			<input type="checkbox"/>
<input type="checkbox"/>	Incompatibility with Other Materials			<input type="checkbox"/>
<input type="checkbox"/>	Incompatible or can react with strong oxidizers.			<input type="checkbox"/>
<input type="checkbox"/>	Decomposition			<input type="checkbox"/>
<input type="checkbox"/>	Normal combustion forms carbon dioxide; incomplete combustion may produce carbon monoxide.			<input type="checkbox"/>
<input type="checkbox"/>	Polymerization			<input type="checkbox"/>
<input type="checkbox"/>	Polymerization will not occur.			<input type="checkbox"/>

<input type="checkbox"/>	11. TOXICOLOGICAL INFORMATION			<input type="checkbox"/>

<input type="checkbox"/>	Animal Data			<input type="checkbox"/>
<input type="checkbox"/>	Mouse skin painting studies have shown that highly refined petroleum lube base oils similar to ingredients in this product have not caused skin tumors. <input type="checkbox"/>			<input type="checkbox"/>

<input type="checkbox"/>	12. ECOLOGICAL INFORMATION			<input type="checkbox"/>

<input type="checkbox"/>	Ecotoxicological Information			<input type="checkbox"/>
<input type="checkbox"/>	No specific aquatic data available for this product.			<input type="checkbox"/>

<input type="checkbox"/>	13. DISPOSAL CONSIDERATIONS			<input type="checkbox"/>

<input type="checkbox"/>	Waste Disposal			<input type="checkbox"/>
<input type="checkbox"/>	Treatment, storage, transportation, and disposal must be in accordance with applicable Federal, State/Provincial, and Local regulations. Do not flush to surface water or sanitary sewer system. <input type="checkbox"/>			<input type="checkbox"/>
<input type="checkbox"/>	Container Disposal <input type="checkbox"/>			<input type="checkbox"/>
<input type="checkbox"/>	Empty drums should be completely drained, properly bunged, and promptly shipped to the supplier or a drum reconditioner. All other containers should be disposed of in an environmentally safe manner. <input type="checkbox"/>			<input type="checkbox"/>

<input type="checkbox"/>	14. TRANSPORTATION INFORMATION			<input type="checkbox"/>

<input type="checkbox"/>	Shipping Information			<input type="checkbox"/>
<input type="checkbox"/>	DOT:	Not regulated. <input type="checkbox"/>		<input type="checkbox"/>
<input type="checkbox"/>	IATA/IMDG:	Not restricted. <input type="checkbox"/>		<input type="checkbox"/>
<input type="checkbox"/>	Canada:	Not regulated. <input type="checkbox"/>		<input type="checkbox"/>

<input type="checkbox"/>	15. REGULATORY INFORMATION			<input type="checkbox"/>

<input type="checkbox"/>	U.S. Federal Regulations			<input type="checkbox"/>
<input type="checkbox"/>	OSHA HAZARD DETERMINATION <input type="checkbox"/>			<input type="checkbox"/>
<input type="checkbox"/>	This material is not known to be hazardous as defined by OSHA's Hazard Communication Standard, 29 CFR 1910.1200. <input type="checkbox"/>			<input type="checkbox"/>

CERCLA/SUPERFUND

Not applicable; this material is covered by the CERCLA petroleum

exclusion.

SARA, TITLE III, 302/304

Extremely Hazardous Substance: None

SARA, TITLE III, 311/312 HAZARD CLASSIFICATIONS

Acute: No

Chronic: No

Fire: No

Reactivity: No

Pressure: No

SARA, TITLE III, 313

Toxic Chemical: None

TSCA

Material and/or components are listed in the TSCA Inventory of

Chemical Substances (40 CFR 710).

RCRA

This material has been evaluated for RCRA characteristics and does

not meet hazardous waste criteria if discarded in its purchased

form. Because of product use, transformation, mixing, processing,

etc., which may render the resulting material hazardous, it is the

product user's responsibility to determine at the time of disposal

whether the material meets RCRA hazardous waste criteria.

CLEAN WATER ACT

The material contains the following ingredient(s) which is considered

hazardous if spilled into navigable waters and therefore reportable

to the National Response Center (1-800-424-8802).

Ingredient: Petroleum Hydrocarbons.

Reportable Quantity: Film or sheen upon or discoloration of

any water surface.

State Regulations (U.S.)

CALIFORNIA "PROP 65"

Ingredients subject to the Act: None.

PENNSYLVANIA WORKER & COMMUNITY RIGHT TO KNOW ACT

Ingredients subject to the Act: None.

Canadian Regulations

This is not a WHMIS Controlled Product.

16. OTHER INFORMATION

NOTE: This product or any other hydrocarbon-based lubricant should not be

used in non-diaphragm compressors that produce "breathing air"

unless the outlet is monitored continuously for carbon monoxide.

These lubricants can produce carbon monoxide when subjected to high

temperatures.

The data in this Material Safety Data Sheet relates only to the

specific material designated herein and does not relate to use in

combination with any other material or in any process.

☐				☐
☐	Responsibility for MSDS:	DNA - SHE	☐	
☐	Address:	Conoco Inc.		☐
☐		PO Box 2197		☐
☐		Houston, TX 77252		☐
☐	Telephone:	1-281-293-5550		☐
☐	Web Site:	www.conoco.com☐		
☐			☐	
☐	# Indicates updated section.			☐
☐		End of MSDS		☐
☐☐				
☐☐				



SECTION 1 - PRODUCT AND COMPANY IDENTIFICATION

PRODUCT IDENTIFICATION: . . : GERALYN AW 68

MANUFACTURER IDENTIFICATION

Company Name : FUCHS LUBRICANTS CO.
 Address : 17050 LATHROP AVE.
 HARVEY IL 60426
 Telephone : 708-333-8900
 Emergency Contact : Regulatory Compliance Department
 Emergency Telephone . . . : 708-333-8900 (8am - 5pm CST, M-F)
 800-255-3924 (24 Hours)

MSDS PRINT DATE : 07/26/2007

* EMERGENCY OVERVIEW

This product is a liquid that is insoluble in water.
 Direct eye contact may cause minor, short term irritation. Short term skin exposure is not expected to be irritating. Inhalation and ingestion are not anticipated routes of exposure during normal conditions of use.

* HMIS Rating: Health- 1 Flammability- 1 Reactivity- 0 PPE- X

SECTION 2 - COMPONENT DATA

Components listed in this section may contribute to the potential hazards associated with exposure to the concentrate. The product may contain additional non-hazardous or trade-secret components.

Mineral Oil	Cas#: proprietary	Percent: > 90
Exposure Limit:		
ACGIH TLV:	5 mg/m3 (as mist)	
ACGIH STEL:	10 mg/m3 (as mist)	
OSHA PEL:	5 mg/m3 (as mist)	

- Carcinogenic Components: This product contains no carcinogens.

SECTION 3 - HAZARDS IDENTIFICATION

POTENTIAL HEALTH EFFECTS and SYMPTOMS from SHORT TERM/ACUTE EXPOSURE:

- EYE EXPOSURE -
 This product is not expected to cause eye irritation under normal conditions of use. Symptoms of slight eye irritation may result when direct contact occurs, or when exposed to high mist levels in poorly ventilated areas.
- SKIN EXPOSURE -
 Short term skin contact is not expected to cause skin irritation. Prolonged or repeated direct exposure to the skin may result in



PRODUCT NAME: GERALYN AW 68

symptoms of irritation and redness. In severe cases, prolonged or repeated contact may result in dermatitis accompanied by symptoms of irritation, itching, dryness, cracking and/or inflammation.

- INHALATION -

This product has low volatility and so is not expected to cause respiratory tract irritation during normal conditions of use. Exposure to high mist levels in poorly ventilated areas may cause upper respiratory tract irritation and difficulty breathing.

- INGESTION -

Ingestion may cause slight stomach irritation and discomfort.

POTENTIAL CHRONIC HEALTH EFFECTS:

No further data known.

MEDICAL CONDITIONS AGGRAVATED BY EXPOSURE:

No further data known.

CARCINOGENICITY:

This product is not listed as a known or suspected carcinogen by IARC, OSHA, or the NTP.

SECTION 4 - FIRST AID MEASURES

EYE CONTACT:

Upon direct eye contact, hold eyelids open and flush with a steady, gentle stream of water for at least 15 minutes. If irritation is due to exposure to mist or vapors, remove the individual to fresh air. If irritation persists, flush the eyes with clean water until the irritation subsides. If symptoms persist, contact a physician.

SKIN CONTACT:

Remove product from the skin by washing with a mild soap and water. Contaminated clothing should be removed to prevent prolonged exposure. If symptoms of exposure persist, contact a physician.

INHALATION:

Inhalation is not an expected route of exposure. If respiratory irritation or distress occurs, remove the employee to fresh air. Contact a physician or other medical professional if irritation or distress persists.

INGESTION:

If small amounts are ingested, first aid measures are not likely to be necessary. If larger amounts are ingested or if symptoms of ingestion occur, dilute stomach contents with two glasses of water or milk. (NOTE: Do NOT give anything by mouth to an unconscious person.) Do not induce



PRODUCT NAME: GERALYN AW 68

vomiting without medical supervision. If vomiting occurs spontaneously keep airway clear. If symptoms of ingestion persist, seek medical attention.

NOTE TO PHYSICIAN:
No further data known.

SECTION 5 - FIRE FIGHTING MEASURES

FIRE AND EXPLOSIVE PROPERTIES:

Flashpoint	:	445.0	CF	COC
Flammability Limits	:	LEL		-N/A
		UEL		-N/A

EXTINGUISHING MEDIA:

In accordance with NFPA guidance, dry chemical, foam, or CO2 fire extinguishers are all acceptable. Note that while water fog extinguishers are also acceptable, do NOT apply a direct stream of water onto burning product because it may cause spreading and increase fire intensity.

UNUSUAL FIRE & EXPLOSION HAZARDS:

No further data known.

FIRE-FIGHTING PROCEDURES AND EQUIPMENT:

Emergency responders in the danger area should wear bunker gear and self-contained breathing apparatus for fires beyond the incipient stage. See Section 8 of the MSDS for other PPE to be worn as conditions warrant.

SECTION 6 - ACCIDENTAL RELEASE MEASURES

CLEAN-UP MEASURES:

Important: As with any spill or leak, before responding ensure that you are familiar with the potential hazards and recommendations of the MSDS. Appropriate personal protective equipment must be worn. See Section 8 of this MSDS for PPE recommendations.

If possible, safely contain the spill with dikes or other spill response equipment appropriate for petroleum or organic material releases. Take measures to prevent spreading of product. Note that while product will ignite it will not readily burn. However, as a precaution eliminate ignition sources. Prevent from entering sewers or waterways. Large volumes may be transferred to an appropriate container for proper disposal. Small volumes or residues may be soaked up with absorbents. Spill response materials should be collected for proper disposal.

SECTION 7 - HANDLING AND STORAGE

HANDLING:



PRODUCT NAME: GERALYN AW 68

As with any industrial chemical, handle the product in a manner that minimizes exposure to practicable levels. Prior to handling, consult Section 8 of this MSDS to evaluate personal protective equipment needs. Open containers slowly to relieve any pressure. Follow all other standard industrial hygiene practices.

Empty containers may contain product residue. All safety precautions taken when handling this product should also be taken when handling empty drums and containers. Keep containers closed when not in use.

Product residue in empty containers is combustible but will not readily burn. NOTE however, that excessive heating or cutting of empty containers may create an ignition source sufficient to start a fire and in extreme cases, cause an explosion.

STORAGE:

Protect product quality by storing indoors and away from extreme temperatures. Close all containers when not in use.

SPECIAL COMMENTS:

No further data known.

SECTION 8 - EXPOSURE CONTROLS, PERSONAL PROTECTION

PERSONAL PROTECTIVE EQUIPMENT:

Selection of personal protective equipment should be based upon the anticipated exposure and made in accordance with OSHA's Personal Protective Equipment Standard found in 29 CFR 1910 Subpart I. The following information may be used to assist in PPE selection.

- EYE PROTECTION -

Wear eye protection appropriate to prevent eye exposure. Where splashing is not likely, chemical safety glasses with side shields are recommended. Where splashing may occur, chemical goggles or full face shield is recommended.

- SKIN PROTECTION -

Gloves are not normally needed during normal conditions of use. If health effects are experienced, oil or chemical resistant gloves such as butyl or nitrile are recommended.

Where splashing or soaking is likely, wear oil or chemical resistant clothing to prevent exposure.

- RESPIRATORY PROTECTION -

A respirator may be worn to reduce exposure to vapors, dust, or mist. Select a NIOSH/MSHA approved respirator appropriate for the type and physical character of the airborne material. A self-contained breathing



PRODUCT NAME: GERALYN AW 68

apparatus is recommended in all situations where airborne contaminant concentration has not been confirmed to be below safe levels. Respirator use should comply with the OSHA Respirator Protection Standard found in 29 CFR 1910.134.

ENGINEERING CONTROLS:

Normal general ventilation is expected to be adequate. It is recommended that ventilation be designed in all instances to maintain airborne concentrations at lowest practicable levels. Ventilation should at a minimum, prevent airborne concentrations from exceeding any exposure limits listed in Section 2 of this MSDS.

The user may wish to refer to 29 CFR 1910.1000(d)(2) and the ACGIH "Threshold Limit Values for Chemical Substances and Physical Agents Biological Exposure Indices" (Appendix C) for the determination of exposure limits of mixtures. An industrial hygienist or similar professional may be consulted to confirm that the calculated exposure limits apply.

SECTION 9 - PHYSICAL AND CHEMICAL PROPERTIES

Physical Appearance : Water white
Odor : Mild petroleum
Physical State : Liquid
Water Solubility : Insoluble
Specific Gravity : .868

SECTION 10 - STABILITY AND REACTIVITY

INCOMPATIBILITIES:

This product is incompatible with strong oxidizing agents.

DECOMPOSITION PRODUCTS MAY INCLUDE:

Thermal decomposition products are dependent on combustion conditions. A complex mixture of airborne solid, liquid, particulates and gasses may evolve when the material burns. Combustion byproducts may include:
oxides of carbon,
incompletely burned hydrocarbons as fumes and smoke.

CONDITIONS TO AVOID:

Avoid contact with incompatible materials and exposure to extreme temperatures.

POLYMERIZATION:

This product is not expected to polymerize.

STABILITY:



PRODUCT NAME: GERALYN AW 68

This product is stable.

SECTION 11 - TOXICOLOGICAL INFORMATION

EYE EFFECTS:

No further toxicological data known.

SKIN EFFECTS:

No further toxicological data known.

ORAL EFFECTS:

No further toxicological data known.

INHALATION EFFECTS:

No further toxicological data known.

OTHER:

No further data known.

SECTION 12 - ECOLOGICAL INFORMATION

ECOTOXICOLOGICAL INFORMATION:

This product has not been evaluated for ecotoxicity. As with any industrial chemical, exposure to the environment should be prevented and minimized wherever possible.

ENVIRONMENTAL FATE:

The degree of biodegradability and persistence of this product has not been determined.

SECTION 13 - DISPOSAL CONSIDERATIONS

WASTE DISPOSAL:

Ensure that collection, transport, treatment, and disposal of waste product, containers and rinsate complies with all applicable laws and regulations. Note that use, mixture, processing, or contamination of the product may cause the material to be classified as a hazardous waste. It is the responsibility of the product user or owner to determine at the time of disposal, whether the product is regulated as a hazardous waste.

SECTION 14 - TRANSPORT INFORMATION

DOT HAZARDOUS MATERIAL INFORMATION:

* Not otherwise DOT regulated.

SECTION 15 - REGULATORY INFORMATION

FEDERAL REGULATIONS:



PRODUCT NAME: GERALYN AW 68

SARA 313:

This product contains NONE of the substances subject to the reporting requirements of Section 313 of Title III of the Superfund Amendments and Reauthorization Act of 1986 and 40 CFR Part 372.

Clean Water Act / Oil Pollution Act:

This product contains mineral oil and is subject to regulation by Section 311 of the Clean Water Act and the Oil Pollution Act. Releases of the product into or leading to surface waters must be reported to the National Response Center at 1-800-424-8802.

CERCLA Reportable Quantity:

Any components listed below have been assigned a reportable quantity (RQ) by the Federal EPA. Releases of the product into the environment that exceed the RQ for a particular component must be reported to the National Response Center at 1-800-424-8802.

Component	RQ
* - * - * - * - * - * - * - * - * - * - * - * - * - *	

Toxic Substances Control Act:

The components of this product are listed on the TSCA Inventory.

Ozone Depleting Substances:

This product contains no ozone depleting substances as defined by the Clean Air Act.

Hazardous Air Pollutants:

Any components listed below are defined by the Federal EPA as hazardous air pollutants.

Component
* - * - * - * - * - * - * - * - * - * - * - * - * - *

STATE REGULATIONS:

This product contains mineral oil, and as used, may be regulated by state used oil regulations. Check with the appropriate state agency to determine whether such a regulation exists.

No further data known.

SECTION 16 - OTHER INFORMATION

Prepared by : Corporate Regulatory Compliance
Date of issue : 07/26/2007
Last Revision Date : 11/01/2006
C4302368

FUCHS LUBRICANTS CO.



PRODUCT NAME: GERALYN AW 68

NOTICE: This MSDS provides a good faith representation of information believed to be accurate as of the last revision date. This document does not create any express or implied product warranties. Since conditions of use are beyond the control of Fuchs Lubricants Co., all risks associated with product use are assumed by the user.



Revision Date: 04/12/2006

Issue date: 04/12/2006

1. CHEMICAL PRODUCT AND COMPANY IDENTIFICATION

Product name: 242® Threadlocker
Product type: Anaerobic Sealant
Company address:
Henkel Corporation
1001 Trout Brook Crossing
Rocky Hill, Connecticut 06067

Item No. : 24231
Region: United States
Contact Information:
Telephone: 860.571.5100
Emergency telephone: 860.571.5100
Internet: www.loctite.com

2. COMPOSITION/INFORMATION ON INGREDIENTS

<u>Hazardous components</u>	<u>%</u>	<u>ACGIH TLV</u>	<u>OSHA PEL</u>	<u>OTHER</u>
Polyglycol dimethacrylate 25852-47-5	60-100	None	None	None
Polyglycol oleate 9004-96-0	10-30	None	None	None
Saccharin 81-07-2	1-5	None	None	None
Silica, amorphous, fumed, crystalline-free 112945-52-5	1-5	6 mg/m ³ TWA	10 mg/m ³ TWA	3 mg/m ³ TWA respirable dust
Cumene hydroperoxide 80-15-9	1-5	None	None	1 ppm (6 mg/m ³) Skin (WEEL), 1ppm, skin TWA, (WEEL)
Propylene glycol 57-55-6	1-5	None	None	10 mg/m ³ TWA, (WEEL)

3. HAZARDS IDENTIFICATION

EMERGENCY OVERVIEW

HMIS:

Physical state: Liquid
Color: Blue
Odor: Mild

HEALTH: 2*
FLAMMABILITY: 1
PHYSICAL HAZARD: 1
Personal Protection: See Section 8

WARNING: CAUSES EYE IRRITATION.
MAY CAUSE SKIN IRRITATION.
MAY CAUSE ALLERGIC SKIN REACTION.
MAY CAUSE RESPIRATORY TRACT IRRITATION.

Relevant routes of exposure: Skin, Inhalation, Eyes

Potential Health Effects

Inhalation: May cause respiratory tract irritation.
Skin contact: May cause allergic skin reaction. May cause skin irritation.
Eye contact: Contact with eyes will cause irritation.
Ingestion: Not expected to be harmful by ingestion.

Item No. : 24231

Product name: 242® Threadlocker

Existing conditions aggravated by exposure:

Eye, skin, and respiratory disorders.

See Section 11 for additional toxicological information.

4. FIRST AID MEASURES

Inhalation: Remove to fresh air. If symptoms develop and persist, get medical attention.

Skin contact: Wash with soap and water. Remove contaminated clothing and shoes. Wash clothing before reuse. Get medical attention if symptoms occur.

Eye contact: Flush with copious amounts of water, preferably, lukewarm water for at least 15 minutes, holding eyelids open all the time. Get medical attention.

Ingestion: Do not induce vomiting. Keep individual calm. Obtain medical attention.

5. FIRE-FIGHTING MEASURES

Flash point: Greater than 93°C (200°F) Tagliabue closed cup

Autoignition temperature: Not available

Flammable/Explosive limits-lower %: 2.6 % (propylene glycol)

Flammable/Explosive limits-upper %: 12.5 % (propylene glycol)

Extinguishing media: Foam, dry chemical or carbon dioxide.

Special fire fighting procedures: None

Unusual fire or explosion hazards: None

Hazardous combustion products: Oxides of carbon. Oxides of sulfur. Oxides of nitrogen. Irritating organic vapors.

6. ACCIDENTAL RELEASE MEASURES

Environmental precautions: Prevent product from entering drains or open waters.

Clean-up methods: Soak up with inert absorbent. Store in a partly filled, closed container until disposal.

7. HANDLING AND STORAGE

Handling: Avoid contact with eyes, skin and clothing. Avoid breathing vapor and mist. Wash thoroughly after handling.

Storage: For safe storage, store at or below 38°C (100°F). Keep in a cool, well ventilated area away from heat, sparks and open flame. Keep container tightly closed until ready for use.

Incompatible products: Refer to Section 10.

For information on product shelf life contact Henkel Customer Service at (800) 243-4874.

8. EXPOSURE CONTROLS / PERSONAL PROTECTION

Engineering controls: No specific ventilation requirements noted, but forced ventilation may still be required if concentrations exceed occupational exposure limits.

Item No. : 24231

Product name: 242® Threadlocker

Respiratory protection: Use NIOSH approved respirator if there is potential to exceed exposure limit(s).

Skin protection: Use impermeable gloves and protective clothing as necessary to prevent skin contact. Neoprene gloves. Butyl rubber gloves. Natural rubber gloves.

Eye/face protection: Safety goggles or safety glasses with side shields.

See Section 2 for exposure limits.

9. PHYSICAL AND CHEMICAL PROPERTIES

Physical state: Liquid
Color: Blue
Odor: Mild
Vapor pressure: Less than 5 mm Hg at 27°C (80°F)
pH: Not applicable
Boiling point/range: Greater than 149°C (300°F)
Melting point/range: Not available
Specific gravity: 1.1 at 23.9°C (75°F)
Vapor density: Not available
Evaporation rate: Not available
Solubility in water: Slight
Partition coefficient (n-octanol/water): Not available
VOC content: 4.48%; 49.3 grams/liter (EPA Method 24)

10. STABILITY AND REACTIVITY

Stability: Stable.

Hazardous polymerization: Will not occur.

Hazardous decomposition products: Oxides of carbon. Oxides of sulfur. Oxides of nitrogen. Irritating organic vapors.

Incompatibility: Strong oxidizers. Free radical initiators. Strong reducing agents. Alkalis. Oxygen scavengers. Other polymerization initiators. Copper. Iron. Zinc. Aluminum. Rust.

Conditions to avoid: See "Handling and Storage" (Section 7) and "Incompatibility" (Section 10).

11. TOXICOLOGICAL INFORMATION

Product toxicity data: Acute oral LD50 greater than 10,000 mg/kg (rat). Acute dermal LD50 greater than 5000 mg/kg (rabbit).

Carcinogen Status

Hazardous components	NTP Carcinogen	IARC Carcinogen	OSHA Carcinogen
Polyglycol dimethacrylate 25852-47-5	No	No	No
Polyglycol oleate 9004-96-0	No	No	No
Saccharin 81-07-2	No	No	No
Silica, amorphous, fumed, crystalline-free 112945-52-5	No	No	No
Cumene hydroperoxide 80-15-9	No	No	No
Propylene glycol 57-55-6	No	No	No

Literature Referenced Target Organ & Other Health Effects

Item No. : 24231

3 of 5

Product name: 242® Threadlocker

Hazardous components	Health Effects/Target Organs
Polyglycol dimethacrylate 25852-47-5	Allergen, Irritant
Polyglycol oleate 9004-96-0	Irritant
Saccharin 81-07-2	No Target Organs
Silica, amorphous, fumed, crystalline-free 112945-52-5	Nuisance dust
Cumene hydroperoxide 80-15-9	Allergen, Central nervous system, Corrosive, Irritant, Mutagen
Propylene glycol 57-55-6	Irritant

12. ECOLOGICAL INFORMATION

Ecological information: Not available

13. DISPOSAL CONSIDERATIONS

Information provided is for unused product only.

Recommended method of disposal: Dispose of according to Federal, State and local governmental regulations.

EPA hazardous waste number: Not a RCRA hazardous waste.

14. TRANSPORT INFORMATION

U.S. Department of Transportation Ground (49 CFR):

Proper shipping name: Unrestricted
Hazard class or division: None
Identification number: None
Packing group: None

International Air Transportation (ICAO/IATA):

Proper shipping name: Unrestricted
Hazard class or division: None
Identification number: None
Packing group: None

WaterTransportation (IMO/IMDG):

Proper shipping name: Unrestricted
Hazard class or division: None
Identification number: None
Packing group: None
Marine pollutant: None

15. REGULATORY INFORMATION

United States Regulatory Information

TSCA 8 (b) Inventory Status:	All components are listed or are exempt from listing on the Toxic Substances Control Act Inventory.
TSCA 12 (b) Export Notification:	4-Methoxyphenol (150-76-5).
CERCLA/SARA Section 302 EHS:	None above reporting de minimus.
CERCLA/SARA Section 311/312:	Immediate Health Hazard, Delayed Health Hazard
CERCLA/SARA 313:	This product contains the following toxic chemicals subject to the reporting requirements of section 313 of the Emergency Planning and Community Right-To-Know Act of 1986 (40 CFR 372). Cumene hydroperoxide (CAS# 80-15-9) .
California Proposition 65:	This product contains a chemical known to the State of California to cause cancer and birth defects or other reproductive harm.

Canada Regulatory Information

CEPA DSL/NDSL Status:	All components are listed on or are exempt from listing on the Domestic Substances List.
WHMIS hazard class:	D.2.B

16. OTHER INFORMATION

This material safety data sheet contains changes from the previous version in sections: 15

Prepared by: Kyra Kozak Woods, Product Safety and Regulatory Affairs Specialist

DISCLAIMER: The data contained herein are furnished for information only and are believed to be reliable. However, Henkel Corporation does not assume responsibility for any results obtained by persons over whose methods Henkel Corporation has no control. It is the user's responsibility to determine the suitability of Henkel's products or any production methods mentioned herein for a particular purpose, and to adopt such precautions as may be advisable for the protection of property and persons against any hazards that may be involved in the handling and use of any of Henkel Corporation's products. In light of the foregoing, Henkel Corporation specifically disclaims all warranties, express or implied, including warranties of merchantability and fitness for a particular purpose, arising from sale or use of Henkel Corporation's products. Henkel Corporation further disclaims any liability for consequential or incidental damages of any kind, including lost profits.



Revision Date: 04/01/2004

Issue date: 04/01/2004

1. CHEMICAL PRODUCT AND COMPANY IDENTIFICATION

Product name: Loctite(R) 7649 Primer N
Product type: Accelerator
Company address:
Henkel Corporation
1001 Trout Brook Crossing
Rocky Hill, Connecticut 06067

Item number: 19269
Region: United States
Contact Information:
Telephone: 860.571.5100
Emergency telephone: 860.571.5100
Internet: www.loctite.com

2. COMPOSITION/INFORMATION ON INGREDIENTS

<u>Hazardous components</u>	<u>%</u>	<u>ACGIH TLV</u>	<u>OSHA PEL</u>	<u>OTHER</u>
Acetone 67-64-1	60-100	500 ppm TWA 750 ppm STEL	1000 ppm TWA 2400 mg/m ³ TWA	None
2-Ethylhexanoic acid 149-57-5	0.1-1	5 mg/m ³ TWA	None	None

3. HAZARDS IDENTIFICATION

EMERGENCY OVERVIEW

HMIS:

Physical state: Liquid
Color: Green
Odor: Acetone

HEALTH: 2*
FLAMMABILITY: 3
PHYSICAL HAZARD: 0
Personal Protection: See Section 8

DANGER: FLAMMABLE LIQUID AND VAPOR.
CAUSES EYE AND SKIN IRRITATION.
MAY CAUSE RESPIRATORY TRACT IRRITATION.

Relevant routes of exposure: Inhalation, Skin contact, Eye contact, Ingestion

Potential Health Effects

Inhalation: Harmful if inhaled. Vapors and mists will irritate nose and throat and possibly eyes. May cause respiratory tract irritation. Headache, dizziness, nausea, and loss of coordination are indications of excessive exposure to vapors or spray mists.

Skin contact: May cause skin irritation. Solvent action can dry and defat the skin, causing the skin to crack, leading to dermatitis.

Eye contact: Vapors may irritate eyes. Contact with eyes will cause irritation.

Ingestion: Harmful if swallowed.

Existing conditions aggravated by exposure: Eye, skin, and respiratory disorders.

See Section 11 for additional toxicological information.

4. FIRST AID MEASURES

Inhalation:	Remove to fresh air. If discomfort persists seek medical attention.
Skin contact:	Wash with soap and water.
Eye contact:	Flush with copious amounts of water, preferably, lukewarm water for at least 15 minutes, holding eyelids open all the time.
Ingestion:	If conscious, drink plenty of water. Do not induce vomiting. Keep individual calm. Obtain medical attention.

5. FIRE-FIGHTING MEASURES

Flash point:	-20°C (-4°F) (estimated)
Autoignition temperature:	465°C (869°F)
Flammable/Explosive limits-lower %:	2.6 %
Flammable/Explosive limits-upper %:	13 %
Extinguishing media:	Foam, dry chemical or carbon dioxide.
Special fire fighting procedures:	None
Unusual fire or explosion hazards:	Vapors may accumulate in low or confined areas, travel considerable distance to source of ignition, and flash back.
Hazardous combustion products:	Oxides of carbon. Oxides of nitrogen. Irritating organic vapors.

6. ACCIDENTAL RELEASE MEASURES

Environmental precautions:	Prevent product from entering drains or open waters.
Clean-up methods:	Remove all ignition sources. Ensure adequate ventilation. Soak up with inert absorbent. Store in a closed container until ready for disposal.

7. HANDLING AND STORAGE

Handling:	Avoid contact with eyes, skin and clothing. Avoid breathing vapor and mist. Wash thoroughly after handling. During use and until all vapors are gone: Keep area ventilated - do not smoke; extinguish all flames, pilot lights, and heaters; turn off stoves, electrical tools and appliances, and any other sources of ignition.
Storage:	Store away from heat, sparks, flames, or other sources of ignition. For safe storage, store at or below 49°C (120°F).
Incompatible products:	Refer to Section 10.

For information on product shelf life contact Henkel Customer Service at (800) 243-4874.

8. EXPOSURE CONTROLS / PERSONAL PROTECTION

Engineering controls:	Use local ventilation if general ventilation is insufficient to maintain vapor concentration below established exposure limits.
Respiratory protection:	Use NIOSH approved respirator if there is potential to exceed exposure limit(s).

Item number: 19269

Product name: Loctite(R) 7649 Primer N

Skin protection: Chemical resistant, impermeable gloves.
Eye/face protection: Safety goggles or safety glasses with side shields.

See Section 2 for exposure limits.

9. PHYSICAL AND CHEMICAL PROPERTIES

Physical state: Liquid
Color: Green
Odor: Acetone
Vapor pressure: 172 mmHg at 20 °C (68 °F)
pH: Not applicable
Boiling point/range: 56°C (133°F)
Melting point/range: Not available
Specific gravity: 0.7936
Vapor density: 2.0
Evaporation rate: 1.9 (Ether = 1)
Solubility in water: Completely miscible
Partition coefficient (n-octanol/water): Not available
VOC content: 1.48%; 11.7 grams/liter (EPA Method 24)

10. STABILITY AND REACTIVITY

Stability: Stable.
Hazardous polymerization: Will not occur.
Hazardous decomposition products: Oxides of carbon. Oxides of nitrogen. Irritating organic vapors.
Incompatibility: Strong oxidizers.
Conditions to avoid: See "Handling and Storage" (Section 7) and "Incompatibility" (Section 10).

11. TOXICOLOGICAL INFORMATION

Carcinogen Status

Hazardous components	NTP Carcinogen	IARC Carcinogen	OSHA Carcinogen
Acetone	No	No	No
2-Ethylhexanoic acid	No	No	No

Literature Referenced Target Organ & Other Health Effects

Hazardous components	Health Effects/Target Organs
Acetone	Blood, Central nervous system, Irritant, Reproductive
2-Ethylhexanoic acid	Developmental, Eyes, Irritant, Liver, Reproductive

12. ECOLOGICAL INFORMATION

Ecological information: Not available

13. DISPOSAL CONSIDERATIONS

Information provided is for unused product only.

Recommended method of disposal: Dispose of according to Federal, State and local governmental regulations.

EPA hazardous waste number: D001: Ignitable.

Item number: 19269

Product name: Loctite(R) 7649 Primer N

14. TRANSPORT INFORMATION

U.S. Department of Transportation Ground (49 CFR):

Proper shipping name: Acetone
Hazard class or division: 3
Identification number: UN 1090
Packing group: II
Exceptions: Consumer Commodity ORM-D (Not more than 1 Liter)

International Air Transportation (ICAO/IATA):

Proper shipping name: Acetone
Hazard class or division: 3
Identification number: UN 1090
Packing group: II
Exceptions: Consumer Commodity ID8000 (Not more than 500 ml)

WaterTransportation (IMO/MDG):

Proper shipping name: Acetone
Hazard class or division: 3
Identification number: UN 1090
Packing group: II
Exceptions: Dangerous goods in limited quantities of class 3 (Not more than 1 liter(s))
Marine pollutant: None

15. REGULATORY INFORMATION

United States Regulatory Information

TSCA 8 (b) Inventory Status: All components are listed or are exempt from listing on the Toxic Substances Control Act Inventory.
TSCA 12 (b) Export Notification: Acetone (CAS# 67-64-1).

CERCLA/SARA Section 302 EHS: None.
CERCLA/SARA Section 311/312: Immediate Health Hazard, Delayed Health Hazard, Fire
CERCLA/SARA 313: None above reporting de minimus.

California Proposition 65: This product contains a chemical known to the State of California to cause cancer and birth defects or other reproductive harm. Nickel (CAS# 7440-02-0). Cobalt (CAS# 7440-48-4). Formaldehyde (CAS# 50-00-0). Acetaldehyde (CAS# 75-07-0). Benzene (CAS# 71-43-2).

Canada Regulatory Information

CEPA DSL/NDSL Status: All components are listed on or are exempt from listing on the Domestic Substances List.
WHMIS hazard class: B.2, D.2.A, D.2.B

16. OTHER INFORMATION

This material safety data sheet contains changes from the previous version in sections: Expanded chemical information in Section 2 and related sections.

Prepared by: Kyra Kozak Woods, Health and Regulatory Affairs Specialist

DISCLAIMER: The data contained herein are furnished for information only and are believed to be reliable. However, Henkel Corporation does not assume responsibility for any results obtained by persons over whose methods Henkel Corporation has no control. It is the user's responsibility to determine the suitability of Henkel's products or any production methods mentioned herein for a particular purpose, and to adopt such precautions as may be advisable for the protection of property and persons against any hazards that may be involved in the handling and use of any of Henkel Corporation's products. In light of the foregoing, Henkel Corporation specifically disclaims all warranties, express or implied, including warranties of merchantability and fitness for a particular purpose, arising from sale or use of Henkel Corporation's products. Henkel Corporation further disclaims any liability for consequential or incidental damages of any kind, including lost profits.

Item number: 19269

Product name: Loctite(R) 7649 Primer N

4 of 4