



# **STREAMLINE SL-V SRP 100 WATERJET INTENSIFIER**

## **OPERATION AND MAINTENANCE MANUAL**



## **NOTICE**

This document contains subject matter in which KMT Waterjet Systems has proprietary rights. Recipients of this document shall not duplicate, use or disclose information contained herein, in whole or in part, for other than the purpose for which this manual was provided.

KMT Waterjet believes the information described in this manual to be accurate and reliable. Much care has been taken in its preparation; however, the Company cannot accept any responsibility, financial or otherwise, for any consequences arising out of the use of this material. The information contained herein is subject to change, and revisions may be issued advising of such changes and/or additions.

## **KMT WATERJET SYSTEMS 2007**



KMT Waterjet Systems  
635 West 12<sup>th</sup> Street  
POB 231  
Baxter Springs, KS 66713-0231

Phone: (800) 826-9274  
Fax: (620) 856-5050

# TABLE OF CONTENTS

Title Page  
Notice  
Table of Contents  
Appendix

<i>Section</i>	<i>Page</i>
<b>1 Introduction .....</b>	<b>1-1</b>
1.1 Overview .....	1-1
1.2 Performance Features and Options .....	1-1
1.3 Operational Overview .....	1-3
Low Pressure Water System .....	1-3
Recirculation System .....	1-3
Hydraulic System .....	1-3
High Pressure Water System .....	1-4
Operating System .....	1-4
1.4 Safety .....	1-5
Lockout/Tagout Procedure .....	1-5
Warning Labels .....	1-6
Emergency Medical Treatment .....	1-8
1.5 Worldwide Product Support .....	1-9
1.6 Spare Parts .....	1-9
1.7 Manual Organization .....	1-9
1.8 Equipment and Service Manual Questionnaire .....	1-10
Terms and Conditions of Sale	
Terms and Conditions, Part Sales	
Terms LD-146, Domestic Service Supervisor	
Terms LD-147, International Service Supervisor	
<b>2 Installation .....</b>	<b>2-1</b>
2.1 Overview .....	2-1
2.2 Installation Summary .....	2-1
2.3 Site Requirements .....	2-2
Transporting .....	2-2
2.4 Power Requirements .....	2-4
2.5 Service Connections .....	2-4
Cooling Water .....	2-5
Cutting Water .....	2-6
Drain .....	2-6
Plant Air .....	2-6

	Contaminated Waste Drain .....	2-6
2.6	Flow Requirements .....	2-7
2.7	High Pressure Piping.....	2-8
	Measurements and Dimensions .....	2-9
	Hand Coning .....	2-10
	Power Coning.....	2-11
	Hand Threading .....	2-12
	Power Threading.....	2-12
2.8	High Pressure Connections .....	2-13
	Standard Connections .....	2-13
	Anti-Vibration Connections.....	2-14
2.9	Commissioning .....	2-15
2.10	Decommissioning .....	2-19
<b>3</b>	<b>Maintenance .....</b>	<b>3-1</b>
3.1	Overview.....	3-1
3.2	Maintenance.....	3-1
	Daily Inspection.....	3-1
	Periodic Maintenance.....	3-1
	High Pressure System Maintenance.....	3-2
3.3	Maintenance Precautions .....	3-3
<b>4</b>	<b>Operation .....</b>	<b>4-1</b>
4.1	Overview.....	4-1
4.2	Startup Sequence.....	4-2
	Startup after Motor Stop .....	4-2
	Startup after Emergency Stop .....	4-2
4.3	Display Controls .....	4-3
4.4	Main Menu.....	4-4
4.5	Run Screens .....	4-4
4.6	Pressure Control Screen.....	4-5
4.7	Setup Screens .....	4-6
4.8	Stroke Rate Screen.....	4-8
4.9	Hours Screen.....	4-9
4.10	Run Screen Alarms .....	4-10
4.11	Alarm Banners .....	4-12
4.12	Alarms Screen.....	4-13
	Installing a New Battery .....	4-15
4.13	Alarm History .....	4-16
	Changing the Date and Time .....	4-16
4.14	Configuration Screen .....	4-16
4.15	Maintenance Screen.....	4-17
4.16	Language Screen.....	4-18
4.17	Configuration II Screen.....	4-18



<b>5</b>	<b>Low Pressure Water System .....</b>	<b>5-1</b>
5.1	Overview.....	5-1
5.2	Cutting Water Supply .....	5-2
5.3	Operation.....	5-2
5.4	Service and Maintenance Procedures .....	5-4
	Filter Assembly and Strainer Maintenance.....	5-4
	Booster Pump Adjustment .....	5-5
<b>6</b>	<b>Recirculation System .....</b>	<b>6-1</b>
6.1	Overview.....	6-1
6.2	Operation.....	6-2
6.3	Service and Maintenance Procedures .....	6-3
	Hydraulic Oil Maintenance.....	6-3
	Oil Filter Maintenance .....	6-6
	Operating Temperature Adjustment .....	6-7
<b>7</b>	<b>Hydraulic System .....</b>	<b>7-1</b>
7.1	Overview.....	7-1
7.2	Optional System Components.....	7-2
7.3	Operation.....	7-2
7.4	Service and Maintenance Procedures .....	7-4
	Hydraulic Operating Pressure .....	7-4
	Motor Maintenance.....	7-6
	Flexible Coupling Replacement.....	7-6
	Hydraulic Compensator Maintenance.....	7-8
	Hydraulic Pump or Electric Motor Replacement.....	7-11
	Hydraulic Oil Replacement.....	7-17
<b>8</b>	<b>Electrical System .....</b>	<b>8-1</b>
8.1	Overview.....	8-1
8.2	Optional System Components.....	8-1
8.3	Operation.....	8-2
	Sensors and Solenoids.....	8-4
8.4	Service and Maintenance Procedures .....	8-9
	Proximity Switch Maintenance.....	8-9
	Optical Relay Maintenance.....	8-10
<b>9</b>	<b>High Pressure Water System .....</b>	<b>9-1</b>
9.1	Overview.....	9-1
9.2	Operation.....	9-2
9.3	System Components.....	9-4
9.4	Service and Maintenance Overview .....	9-5
	Torque Specifications .....	9-6
	Specialized Maintenance Tools .....	9-8
9.5	High and Low Pressure Water Piping.....	9-9
9.6	High Pressure Cylinder Assembly .....	9-9

	High Pressure Cylinder Assembly Removal.....	9-10
	High Pressure Cylinder Assembly Installation.....	9-11
	High Pressure Cylinder Maintenance .....	9-12
9.7	Hard Seal End Caps .....	9-13
	Hard Seal End Cap Removal .....	9-13
	Hard Seal End Cap Installation.....	9-14
9.8	Sealing Head.....	9-15
	High Pressure Discharge Check Valve.....	9-15
	Low Pressure Inlet Check Valve.....	9-17
	Sealing Head Maintenance .....	9-18
9.9	High Pressure Seal Assembly .....	9-19
9.10	Hydraulic Cartridge Seal and Plunger Removal.....	9-21
	Plunger Maintenance .....	9-24
	Plunger Installation.....	9-24
	Hydraulic Cartridge Seal.....	9-25
9.11	Hydraulic Piston.....	9-26
	Hydraulic Piston Removal .....	9-27
	Bearing Rings and Seal Assembly.....	9-29
	Plunger Button Sockets, Seals and Retainer Pins .....	9-30
	Internal Check Valves.....	9-30
	Hydraulic Piston Installation.....	9-31
9.12	Hydraulic Cylinder Maintenance.....	9-32
9.13	High Pressure Attenuator.....	9-32
9.14	High Pressure Dump Valve .....	9-33
	Pneumatic Control Valve.....	9-34
	Pneumatic Actuator.....	9-38
9.15	Weep Holes.....	9-39
<b>10</b>	<b>Troubleshooting .....</b>	<b>10-1</b>
	10.1 Overview.....	10-1
	10.2 Troubleshooting Guide .....	10-2
<b>11</b>	<b>Specifications .....</b>	<b>11-1</b>
	11.1 Overview.....	11-1
	11.2 Installation Specifications.....	11-1
	Environment.....	11-1
	Sound Level .....	11-1
	Equipment Dimensions and Weights.....	11-2
	Service Connections.....	11-2
11.3	Water Specifications .....	11-2
	Cutting Water Supply .....	11-2
	Cooling Water Supply.....	11-3
	Water Quality Standards.....	11-3
11.4	Electrical Specifications.....	11-6
	Electrical System .....	11-6
	Ampacity and Power Voltage Requirements.....	11-6

11.5	Hydraulic and High Pressure Water System Specifications .....	11-6
	Hydraulic System.....	11-6
	High Pressure Water System .....	11-7
	Orifice Capacity .....	11-7
	Torque Specifications .....	11-9
<b>12</b>	<b>Parts List.....</b>	<b>12-1</b>
12.1	Overview.....	12-1
12.2	Part Nomenclature .....	12-2
12.3	Index .....	12-3

## APPENDIX

### *Exhibit*

---

System Schematic  
Electrical Schematics  
Material Safety Data Sheets



## SECTION 1

### INTRODUCTION

#### 1.1 Overview

The SL-V SRP 100 intensifier combines all the unique capabilities and advantages of waterjet cutting systems with the reliability, ease of operation and service support that have made KMT Waterjet Systems a leader in waterjet technology.

**Table 1-1**  
**SL-V SRP 100**

Motor Horsepower Rating		Maximum Operating Pressure	Maximum Flow Rate ( <i>at full pressure</i> )	Maximum Single Orifice Diameter ( <i>at full pressure</i> )
HP	Kw			
100	75	35,000 psi (2,413 bar)	2.8 gpm (10.6 L/min)	0.026 inch (0.66 mm)

#### 1.2 Performance Features and Options

The SL-V SRP 100 intensifier is designed with the same convenience and ease of access for maintenance and service you have come to expect from KMT Waterjet. The hydraulic cylinder head simply bolts to the hydraulic cylinder; each high pressure assembly can be removed and serviced independently, and the hydraulic seal cartridge can be quickly replaced as a single unit.

The robust performance and standard features are the result of aggressive development and decades of experience.

- Continuous operation at 35,000 psi (2,413 bar).
- The innovative hard seal end cap provides a metal-to-metal seal against the sealing head, totally, eliminating the potential for leaks.
- While dramatically increasing seal life, the unique design of the patented HyperLife™ seal conforms to the cylinder bore as it expands under pressure, creating an absolute seal.
- The quick release design of the plunger greatly simplifies removal and installation.
- Comprehensive fault detection and troubleshooting logic monitor crucial pressure, temperature and fluid levels.
- Warning and shutdown sensors guard against potential equipment damage.



Performance options are available at the time of purchase, or as upgrades for existing equipment.

- The KMT Customer Service Department can provide real time diagnostics, troubleshooting and data analysis through a modem interface for remote monitoring of the programmable logic controller (PLC).
- Proportional pressure control allows the operator to select or vary the operating pressure from the control display or remote console.
- The current operating pressure can be viewed from the control display with an optional pressure transducer.

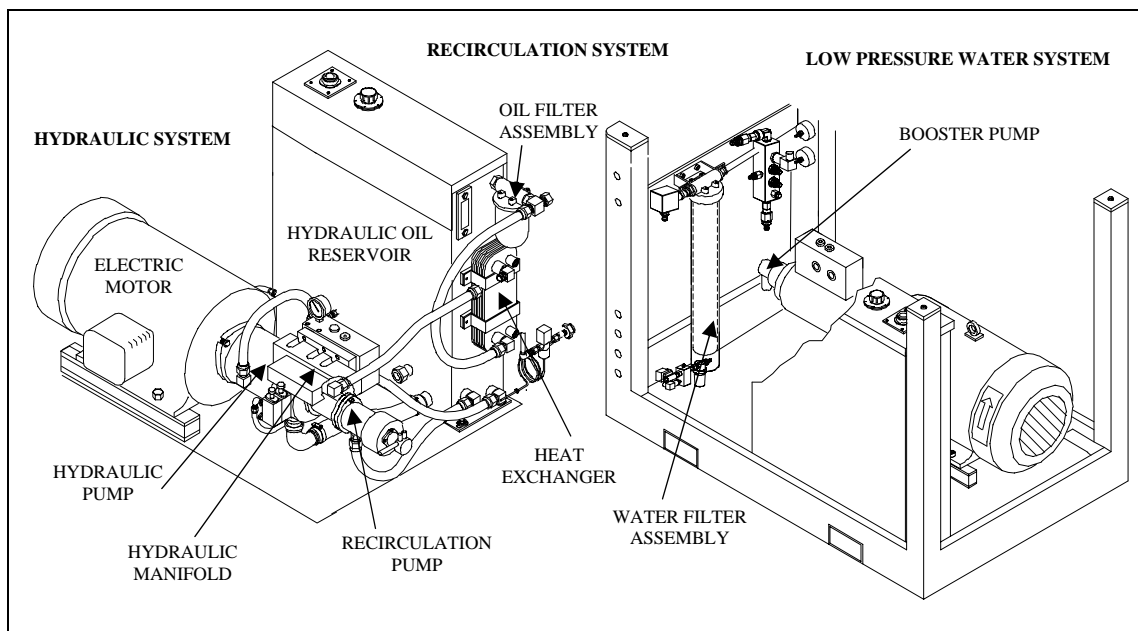
### 1.3 Operational Overview

The following provides a brief overview of the function and primary components associated with the individual systems. A detailed discussion of each system is provided in Sections 4 through 9.

#### Low Pressure Water System

The low pressure water system supplies the cutting water flow to the intensifier. Major system components include the water filter assembly and the booster pump.

*Figure 1-1: System Components*



#### Recirculation System

The recirculation system is a cooling and filtration system that provides properly conditioned oil to the main hydraulic system. Major system components include the recirculation pump, heat exchanger, oil filter assembly and the hydraulic oil reservoir.

#### Hydraulic System

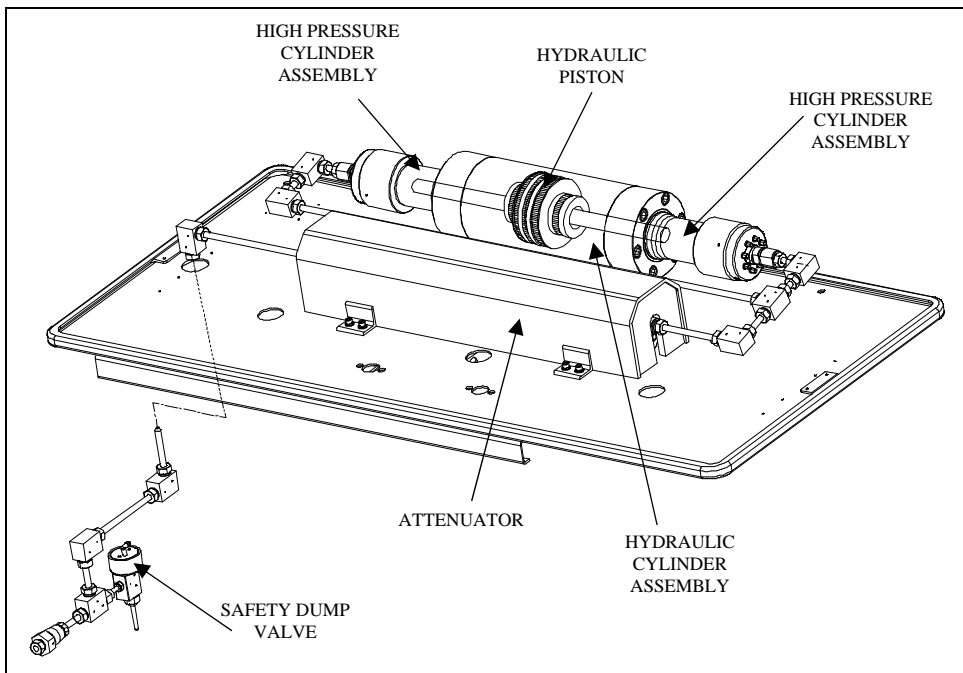
The hydraulic system supplies the intensifier with the hydraulic oil required to produce high pressure water. Major system components include the electric motor, hydraulic pump, 4-way directional control valve mounted on the hydraulic manifold.

## High Pressure Water System

The high pressure water system is the heart of the waterjet system. Water is pressurized and continuously delivered to the cutting head. As water passes through a tiny hole in the orifice, water pressure is converted to water velocity capable of cutting most any material.

The major components include the high pressure cylinder assemblies, hydraulic cylinder assembly, hydraulic piston, attenuator and the safety dump valve.

*Figure 1-2: High Pressure System Components*



## Operating System

A programmable logic controller (PLC) provides basic intensifier shift control and monitors out of limit conditions. Operator interface is through the control panel display where operating parameters are set and monitored.


*Figure 1-3: Control Panel Main Menu*



## 1.4 Safety

The high pressure waterjet cutting system is a high energy cutting tool capable of cutting many dense or strong materials. Do not touch or be exposed to high pressure water. High pressure water will penetrate all parts of the human body. The liquid stream and the material ejected by the extreme pressure can result in severe injury.

All personnel operating, servicing or working near the waterjet cutting equipment shall adhere to the following safety precautions, as well as the applicable plant safety precautions.

- Only KMT factory trained, qualified personnel shall service and maintain the equipment.
- The operator shall practice and promote safety at all times to avoid potential injury and unnecessary downtime.
- The work area around the equipment shall be clean and free of debris and oil spills.
- All protective guards, shields or covers shall be in place on the equipment at all times.
-  Safety glasses and ear protection shall be worn when operating or working near the equipment.

### Lockout/Tagout Procedure

This lockout/tagout procedure is designed to protect all employees from injuries caused by the unexpected energizing or startup of the machine, or the release of stored energy during service and maintenance.

This is accomplished with energy isolating devices that prevent the transmission or release of energy. An energy source is any source of electrical, mechanical, hydraulic, pneumatic, chemical, thermal, or other energy source that could cause injury to personnel.

A lockout device utilizes a lock and key to hold an energy isolating device in the safe position and prevents the machine from being energized. A tagout device is a prominent warning device that can be securely attached to the machine warning personnel not to operate the energy isolating device. This procedure requires the combination of a lockout device and a tagout device.

The lockout/tagout procedure applies to any employee who operates and/or performs service or maintenance on the machine. Before any maintenance or repairs are performed, the machine shall be isolated, and rendered inoperative as follows.

1. Shut down the machine by pressing the STOP button, and open the high pressure cutting water valve to bleed the water and hydraulic pressure from the system.
2. Disconnect, lockout and tag the main, customer supplied, power source.



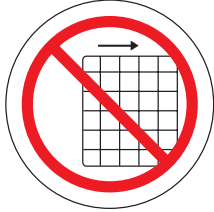


3. Lockout and tag the circuit breaker/disconnect on the electrical enclosure door.
4. Close, lockout and tag the manual shutoff valves for all service connections: cutting water in, cooling water in and out, and air.

### Warning Labels

Warning labels are posted on the machine to indicate potential hazards. The operator and service personnel shall pay particular attention to these warning labels. Table 1-2 describes the necessary precautions and provides the part number required to order replacement labels.

**Table 1-2**  
**Warning Label Precautions**

1	 P/N 05114962	<p>The electrical enclosure and motor junction box can present an electrical shock hazard. Always disconnect and lockout the main power before opening the enclosure.</p> <p>Always disconnect and lockout the main power and the circuit breaker/disconnect on the electrical enclosure door before performing any type of maintenance</p>
2	 P/N 05114970	<p>The surface of high pressure water and hydraulic components becomes hot during normal operation. Failed, or failing components, can become extremely hot during operation.</p>
3	 P/N 80082209	<p>Ensure that all protective guards, shields or covers are in place on the equipment at all times. Never operate the pump with the guards removed.</p>

**Table 1-2**  
**Warning Label Precautions**

4		<p>High pressure water and/or hydraulic pressure can remain in the system even when the pump has been shut off. All pressure can be safely bled from the system by opening the high pressure cutting water valve for a few seconds after shutting off the pump.</p>
	P/N 05098017	<p>Pressing the EMERGENCY STOP button turns the control power to the intensifier off, stops the pump and bleeds the high pressure water through the safety dump valve.</p>
		<p>Depressurization of the high pressure system creates a loud hissing sound when the dump valve opens. The sound fades quickly as the pressure drops.</p>
5		<p>All personnel involved in the installation, operation and/or service of the intensifier must carefully read, understand and follow the procedures in this manual to avoid creating unsafe conditions, risking damage to the equipment, or personal injury.</p>
	P/N 20415794	

Safety precautions and warnings for specific procedures are emphasized throughout this manual as illustrated in the following examples. These precautions must be reviewed and understood by operating and maintenance personnel prior to installing, operating or servicing the machine. Adherence to all Warnings, Cautions and Notes is essential to safe and efficient service and operation.



Warnings emphasize operating or service procedures, or conditions that can result in serious personal injury or death.



Cautions emphasize operating or service procedures, or conditions that can result in equipment damage or impairment of system operation.



**NOTE**

Notes provide additional information that can expedite or improve operating or service procedures.

**Emergency Medical Treatment**

An emergency medical card is included in the binder of this manual. This information should be used to aid in the treatment of a waterjet injury. Additional cards may be obtained by contacting KMT Waterjet Systems using the address or telephone number shown on the card.

**Medical Alert**

This card is to be carried by personnel working with high pressure waterjet equipment. Obtain medical treatment immediately for ANY high pressure waterjet injuries.

**KMT Waterjet Systems  
635 West 12th Street  
Baxter Springs, KS 66713  
(620) 856-2151**

This person has been working with water jetting at pressures to 60,000 psi (374MPa, 4,137 bar, 3867 Kg/cm<sup>2</sup>) with a jet velocity of 3,000 fps (914 mps). Foreign material (sand) may have been injected with water. Unusual infections with microaerophilic organisms occurring at lower temperatures have been reported, such as gram negative pathogens as are found in sewage. Bacterial swabs and blood cultures may therefore be helpful. This injury must be treated as an acute surgical emergency and be evaluated by a qualified surgeon. Circulation may be compromised, therefore, **DO NOT APPLY HEAT TO INJURED PART**. For first aid: (1) Elevate injured part (2) Antibiotics (3) Keep injured person NPO.



## 1.5 Worldwide Product Support

The KMT Waterjet Customer Service Department is available to answer your questions regarding equipment installation and service. Technical assistance is available by phone and on-site support is available on request.

On-site technical assistance is available during equipment installation and startup. Additionally, technical support for service and maintenance issues and training of operators and maintenance personnel is available. Periodic training sessions are also conducted at KMT Waterjet and customer facilities.

Contact the KMT Waterjet Customer Service Department for additional information.

### *USA* Customer Service Department

KMT Waterjet Systems  
PO Box 231  
635 West 12th Street  
Baxter Springs, KS 66713  
USA

Phone: (800) 826-9274  
Fax: (620) 856-2242  
Email: [wj.service@kmtgroup.com](mailto:wj.service@kmtgroup.com)  
Email: [wj.parts@kmtgroup.com](mailto:wj.parts@kmtgroup.com)

### *Europe* Technical Manager

KMT Waterjet Systems GmbH  
Wasserstrahl-Schneidetechnik  
Auf der Laukert 11  
D-61231 Bad Nauheim  
Germany

Phone: +49-6032-997-117  
Fax: +49-6032-997-270  
Email: [order.service@kmt-waterjet.com](mailto:order.service@kmt-waterjet.com)

## 1.6 Spare Parts

KMT Waterjet maintains a well-stocked Spare Parts Department, staffed by trained, knowledgeable personnel. If required, emergency shipment is available. Contact the Customer Service Department to order spare parts, or for additional information.

## 1.7 Manual Organization

This manual contains operating and maintenance procedures for the complete SL-V series. Information is organized as follows:

- Section 1, Introduction, provides an overview of equipment features and options, a brief operational overview, details regarding safety issues and contact information for product support.
- Section 2, Installation, details installation requirements and procedures, and provides systematic guidelines for commissioning the intensifier are also provided.
- Section 3, Maintenance, highlights routine and preventive maintenance requirements. Precautions associated with high pressure cutting equipment are also reviewed.



- Section 4, Operation, explains the control functions and the display panel where operating parameters are set and monitored.
- Sections 5 through 9 are specific to each individual system. Each section contains a detailed description of the principles of operation and the function of each system. Routine maintenance procedures associated with the system are also provided.
- Section 10, Troubleshooting, is a comprehensive guide containing the information required to diagnose problems and repair the machine.
- Section 11, Specifications, contains a comprehensive list of equipment specifications; a detailed discussion of water quality standards and treatment guidelines; as well as flow requirements for various orifice sizes.
- Section 12, Parts List, contains part numbers, descriptions and drawings to facilitate the ordering of replacement parts.

## **1.8 Equipment and Service Manual Questionnaire**

We are interested in your impression of the KMT Waterjet System recently installed at your location. Your comments and recommendations will aid us in our continuing goal to improve our products, and make our technical information more useful to our customers.

At your convenience, please take a few minutes to complete the following questionnaire, and return it to the applicable Customer Service Department listed above.



## Equipment and Service Manual Questionnaire

### 1. General Appearance

Was the unit received in good condition?  Yes  No

Comments: \_\_\_\_\_

Is the unit a convenient size?  Yes  No

### 2. Controls

Are the controls user friendly?  Yes  No

Is the unit easy to operate?  Yes  No

Comments: \_\_\_\_\_

### 3. Performance

Does the unit perform smoothly and meet your expectations?  Yes  No

Does the unit run quietly?  Yes  No

Comments: \_\_\_\_\_

### 4. Did the installation and startup go smoothly?

Yes  No

Comments: \_\_\_\_\_

### 5. What features do you consider the most significant?

Quiet operation \_\_\_\_\_

Appearance \_\_\_\_\_

Performance/Operation \_\_\_\_\_

Repair/Maintenance \_\_\_\_\_

Other \_\_\_\_\_

### 6. What areas could be improved?

Appearance \_\_\_\_\_

Performance \_\_\_\_\_

Serviceability \_\_\_\_\_

Other \_\_\_\_\_



**7. Manual Organization**

Does the Table of Contents help you find topics easily?  Yes  No

Comments: \_\_\_\_\_

Is the information well organized?  Yes  No

Comments: \_\_\_\_\_

Is the page layout suitable for the material being presented?  Yes  No

Comments: \_\_\_\_\_

**8. Graphics**

Are the illustrations suitable for the material being presented?  Yes  No

Comments: \_\_\_\_\_

**9. Text**

Does the information adequately explain how to operate and service the equipment?  Yes  No

Comments: \_\_\_\_\_

Are there paragraphs or procedures you feel need clarification? Please identify them by page number and add your comments.  Yes  No

Comments: \_\_\_\_\_

\_\_\_\_\_

Is there anything you would add or delete to make the manual more useful?  Yes  No

Comments: \_\_\_\_\_

\_\_\_\_\_

Is there any information that should receive more emphasis?  Yes  No

Comments: \_\_\_\_\_

\_\_\_\_\_

---

Name \_\_\_\_\_ Title \_\_\_\_\_

Company \_\_\_\_\_ Date \_\_\_\_\_

Address \_\_\_\_\_

\_\_\_\_\_

\_\_\_\_\_



## Terms and Conditions of Sale

### 1. General

The Terms and Conditions of Sale outlined herein shall apply to the sale by KMT Waterjet Systems Inc. (hereinafter referred to as Company) of products, equipment and parts relating thereto (hereinafter referred to as Equipment). Unless prior written agreement is reached, it shall be understood that the Company's proceeding with any work shall be in accordance with the terms and conditions outlined herein

The Company will comply with applicable laws and regulations in effect on the date of the Company's proposal as they may apply to the manufacture of the Equipment. Compliance with any local governmental laws or regulations relating to the location, use or operation of the Equipment, or its use in conjunction with other equipment, shall be the sole responsibility of the Purchaser.

### 2. Title and Risk of Loss

Title and risk of loss or damage to the Equipment shall pass to the Purchaser upon tender of delivery F.O.B. manufacturing facility unless otherwise agreed upon by the parties, except that a security interest in the Equipment shall remain in the Company, regardless of mode of attachment to realty or other property, until full payment has been made therefor. Purchaser agrees upon request to do all things and acts necessary to perfect and maintain said security interest and shall protect Company's interest by adequately insuring the Equipment against loss or damage from any cause wherein the Company shall be named as an additional insured.

### 3. Assignment

Neither party shall assign or transfer this contract without the prior written consent of the other party. The Company however shall be permitted to assign or transfer, without the prior written consent of the Purchaser, the Company's right to receive all or any portion of the payment due from the Purchaser under this contract.

### 4. Delivery and Delays

Delivery dates shall be interpreted as estimated and in no event shall dates be construed as falling within the meaning of "time is of the essence".

The Company shall not be liable for any loss or delay due to war, riots, fire, flood, strikes or other labor difficulty, acts of civil or military authority including governmental laws, orders, priorities or regulations, acts of the Purchaser, embargo, car shortage, damage or delay in transportation, inability to obtain necessary labor or materials from usual sources, faulty forgings or castings, or other causes beyond the reasonable control of the Company. In the event of delay in performance due to any such cause, the date of delivery or time for completion will be adjusted to reflect the actual length of time lost by reason of such delay. The Purchaser's receipt of Equipment shall constitute a waiver of any claims for delay.

### 5. Taxes

The price does not include any present or future Federal, State, or local property, license, privilege, sales, use, excise, gross receipts or other like taxes or assessments which may be applicable to, measured by, imposed upon or result from this transaction or any services performed in connection therewith. Such taxes will be itemized separately to Purchaser, who shall make prompt payment to the Company. The Company will accept a valid exemption certificate from Purchaser, if applicable. If such exemption certificate is not recognized by the governmental taxing authority involved, Purchaser agrees to promptly reimburse the Company for any taxes covered by such exemption certificate which the Company is required to pay.

### 6. Set Offs

Neither Purchaser nor any affiliated company or assignee shall have the right to claim compensation or to set off against any amounts which become payable to the Company under this contract or otherwise.

### 7. Patents

The Company shall defend any Suit or proceeding brought against the Purchaser and shall pay any adverse judgment entered therein so far as such suit or proceeding is based upon a claim that the use of the Equipment manufactured by the Company, and furnished under this contract constitutes infringement of any patent of the United States of America, providing the Company is promptly notified in writing and given authority, information and assistance for defense of same; and the Company shall, at its option, procure for the Purchaser the right to continue to use said Equipment, or to modify it so that it becomes non-infringing, or to replace the same with non-infringing equipment, or to remove said Equipment and to refund the purchase price. The foregoing shall not be construed to include any agreement by the Company to accept any liability whatsoever in respect to patents for inventions including more than the Equipment furnished hereunder or in respect of patents for methods and processes to be carried out with the aid of said Equipment. The foregoing states the entire liability of the Company with regard to patent infringement.

### 8. Warranty

The Company warrants that the Equipment manufactured by it and delivered hereunder will be free of defects in material and workmanship for a period of twelve months from the date of placing the Equipment in operation or eighteen months from the date of shipment, whichever shall first occur. The Purchaser shall be obligated to promptly report any failure to conform to this warranty, in writing to the company within said period, whereupon the Company shall, at its option, correct such nonconformity, by suitable repair to such Equipment or, furnish a replacement part F.O.B. point of shipment, provided the Purchaser has stored, installed, maintained and operated such Equipment in accordance with good industry practices and has complied with specific recommendations of the Company. Accessories or equipment furnished by the Company, but manufactured by others, shall carry whatever warranty the manufacturers have conveyed to the Company and which can be passed on to the Purchaser. The Company shall not be liable for any repairs, replacements, or adjustments to the Equipment or any costs of labor performed by the Purchaser or others without the Company's prior written approval.

The effects of corrosion, erosion and normal wear and tear are specifically excluded. Performance warranties are limited to those specifically stated within the Company's proposal. Unless responsibility for meeting such performance warranties are limited to specified shop or field tests, the Company's obligation shall be to correct in the manner and for the period of time provided above.

THE COMPANY MAKES NO OTHER WARRANTY OR REPRESENTATION OF ANY KIND WHATSOEVER, EXPRESSED OR IMPLIED, EXCEPT THAT OF TITLE, AND ALL IMPLIED WARRANTIES OF MERCHANTABILITY AND FITNESS FOR A PARTICULAR PURPOSE, ARE HEREBY DISCLAIMED.

Correction by the Company of nonconformities whether patent or latent, in the manner and for the period of time provided above, shall constitute fulfillment of all liabilities of the Company for such nonconformities, whether based on contract warranty, negligence, indemnity, strict liability or otherwise with respect to or arising out of such Equipment.





The Purchaser shall not operate Equipment which is considered to be defective, without first notifying the Company in writing of its intention to do so. Any such use of Equipment will be at the Purchaser's sole risk and liability.

#### **9. Limitation of Liability**

THE REMEDIES OF THE PURCHASER SET FORTH HEREIN ARE EXCLUSIVE, AND THE TOTAL LIABILITY OF THE COMPANY WITH RESPECT TO THIS CONTRACT OR THE EQUIPMENT AND SERVICES FURNISHED HEREUNDER, IN CONNECTION WITH THE PERFORMANCE OR BREACH THEREOF, OR FROM THE MANUFACTURE, SALE, DELIVERY, INSTALLATION, REPAIR OR TECHNICAL DIRECTION COVERED BY OR FURNISHED UNDER THIS CONTRACT, WHETHER BASED ON CONTRACT WARRANTY, NEGLIGENCE, INDEMNITY, STRICT LIABILITY OR OTHERWISE, SHALL NOT EXCEED THE PURCHASE PRICE OF THE UNIT OF EQUIPMENT UPON WHICH SUCH LIABILITY IS BASED.

THE COMPANY AND ITS SUPPLIERS SHALL IN NO EVENT BE LIABLE TO THE PURCHASER, ANY SUCCESSORS IN INTEREST OR ANY BENEFICIARY OR ASSIGNEE OF THIS CONTRACT FOR ANY CONSEQUENTIAL, INCIDENTAL, INDIRECT, SPECIAL OR PUNITIVE DAMAGES ARISING OUT OF THIS CONTRACT OR ANY BREACH THEREOF, OR ANY DEFECT IN, OR FAILURE OF, OR MALFUNCTION OF THE EQUIPMENT HEREUNDER, WHETHER BASED UPON LOSS OF USE, LOST PROFITS OR REVENUE, INTEREST, LOST GOODWILL, WORK STOPPAGE, IMPAIRMENT OF OTHER GOODS, LOSS BY REASON OF SHUTDOWN OR NON-OPERATION, INCREASED EXPENSES OF OPERATION, COST OF PURCHASE OF REPLACEMENT POWER OR CLAIMS OF PURCHASER OR CUSTOMERS OF PURCHASER FOR SERVICE INTERRUPTION WHETHER OR NOT SUCH LOSS OR DAMAGE IS BASED ON CONTRACT, WARRANTY, NEGLIGENCE, INDEMNITY, STRICT LIABILITY OR OTHERWISE.

#### **10. Nuclear Liability**

In the event that the Equipment sold hereunder is to be used in a nuclear facility, the Purchaser shall, prior to such use, arrange for insurance or governmental indemnity protecting the Company against liability and hereby releases and agrees to indemnify the Company and its suppliers for any nuclear damage, including loss of use, in any manner arising out of a nuclear incident, whether alleged to be due, in whole or in part to the negligence or otherwise of the Company or its suppliers.

#### **11. Governing Law**

The rights and obligations of the parties shall be governed by the laws of the State of Delaware excluding any conflicts of law provisions. The United Nations Convention on Contracts for the International Sale of Goods shall not apply to this agreement.

#### **12. Execution**

The Company shall not be bound by any contract or any modification thereto until approved in writing by an officer of the Company. The contract, when so approved shall supersede all previous communications, either oral or written.



## Terms and Conditions

### Part Sales

#### 1. General

The Terms of Conditions outlined herein shall apply to the sales of parts by KMT Waterjet Systems (hereinafter referred to as Company.) No additional or contrary terms shall be binding upon the Company unless agreed to in writing.

#### 2. Schedule Dates and Delays

Schedule dates are approximate and neither party shall be liable for loss, damage, detention, or delay due to war, riots, civil or military authority including governmental laws, orders, priorities or regulations, acts of the other party, embargo, car shortage, wrecks or delay in transportation, inability to obtain necessary labor, materials or manufacturing facilities from usual sources, faulty forgings or castings, or other causes beyond the reasonable control of such party.

Should the Purchaser request special shipping instruction such as exclusive use of shipping facilities, including air freight when common carrier has been quoted and before a change to the order is received by the Company, the additional charges will be honored by Purchaser.

#### 3. Taxes

The prices provided for herein do not include any present or future Federal, State, Municipal sales, use, excise, gross receipts, property, or other similar type tax with respect to any material or equipment covered hereby. If the Company is required by applicable law or regulation to pay or collect any such type tax or taxes on account of this transaction or the material or equipment covered hereby, then such amount of tax shall be paid by the Purchaser in addition to the prices herein provided for.

#### 4. Warranty

The Company warrants that parts manufactured by it will be as specified and will be free from defects in materials and workmanship, the Company's liability under this warranty shall be limited to the repair or replacement of any part F.O.B. point of shipment which was defective at the time of shipment, provided the Purchaser notifies the Company in writing of any such defect promptly upon discovery, but in no event later than six (6) months from the date of shipment of such part by the Company.

Warranties applicable to material and equipment supplied by the Company but wholly manufactured by others shall be limited to the warranties extended to the Company by the manufacturer which are able to be conveyed to the Purchaser.

The Company makes no performance warranty and the effects of corrosion, erosion and normal wear and tear are specifically excluded from the Company's warranty.

THE COMPANY MAKES NO OTHER WARRANTY OR REPRESENTATION OF ANY KIND WHATSOEVER, EXPRESSED OR IMPLIED, EXCEPT THAT OF TITLE, AND ALL IMPLIED WARRANTIES, INCLUDING ANY WARRANTY OF MERCHANTABILITY AND FITNESS FOR A PARTICULAR PURPOSE, ARE HEREBY DISCLAIMED.

#### 5. Limitation of Liability

The remedies of the Purchaser set forth herein are exclusive, and the liability of the Company with respect to this order shall not exceed the purchase price of the part upon which such liability is based.

The Company and its suppliers shall in no event be liable to the Purchaser, any successors in interest or any beneficiary of this order for any consequential, incidental, indirect, special or punitive damages arising out of this order or any breach thereof, whether based upon loss of use, lost profits or revenue interest, lost goodwill, work stoppage, impairment of other goods, loss by reason of shutdown or non-operation, increased expenses of operation, cost of purchase of replacement power or claims of Purchaser or customers of Purchaser for service interruption, whether or not such loss or damage is based on contract, warranty, negligence, indemnity, strict liability or otherwise.

#### 6. Nuclear Liability

In the event that the parts sold hereunder are to be used in a nuclear facility the Purchaser shall, prior to such use, arrange for insurance or governmental indemnity, protecting the Company against liability and hereby suppliers for any nuclear damage, including loss of use, in any manner arising out of a nuclear incident, whether alleged to be due in whole or in part to the negligence or otherwise of the Company or its suppliers.





## Terms LD-146 Domestic Service Supervisor

When KMT Waterjet Systems (hereinafter called the Company) provides the Services of a Service Supervisor (hereinafter called the Supervisor) to consult with and advise the Purchaser in the installation, starting up and/or overhaul or maintenance of equipment of KMT Waterjet manufacture, such Supervisor shall not be responsible for the procurement of labor or mechanical work performed by others. The Service Supervisor's services shall be furnished under the following conditions:

1. All necessary workmen (common, semi-skilled and skilled), together with proper labor supervision shall be furnished by the Purchaser, at his expense. Qualified Support labor must be available to the Supervisor at all times during the Supervisor's work hours. **The Supervisor is prohibited by the Company from working alone.**

2. All necessary utilities shall be furnished by the Purchaser, at his expense.

3. The Supervisor will expect to work consecutive days until the contracted work is complete. For any day the Supervisor is available for work and is denied access, with the exception of national holidays, the Purchaser will be invoiced by the Company for eight (8) hours at the KMT rate in effect at the time of service, plus associated living expenses.

4. The Purchaser shall provide all tools and equipment required for any installation or service work. The Company's Supervisor may bring with him, or ship to the jobsite, special tools which are and shall remain Company property. If such tools are too heavy for transport by the Supervisor, the Purchaser shall assist in arranging for their return to a location designated by the Company at the completion of the services.

5. The Company shall be reimbursed by the purchaser for all transportation costs for any required special tools or equipment, plus replacement costs for any of these items which are not returned to the Company at the completion of the services.

6. The Company agrees that the Supervisor will provide Best Efforts in effecting repairs to equipment supplied by the Company, but provides no guarantee that such Best Efforts will result in restoration of proper operation of equipment the Supervisor is contracted to repair.

7. The Supervisor shall be suitably covered with insurance in the areas of Worker's Compensation, Public Liability and Automobile Insurance where the use of a vehicle is required. Certificates confirming this insurance coverage are obtainable upon request. The Company shall in no event be liable for any loss recoverable by the Purchaser under insurance policies covering Purchaser's property.

8. The Company accepts no responsibility for material or the acts of men furnished by the Purchaser. The Company is not responsible for the rate of progress or the date of completion of the work nor for incorrect operation or damage incurred due to improper storage or handling.

9. The Company shall be permitted to assign all or any portion of its performance under this Contract to a selected Professional Service organization, without the prior consent of the Purchaser.

10. The Company and its affiliates or suppliers shall in no event be liable to the Purchaser, any successors in interest or any beneficiary of this Contract for any consequential, incidental, indirect, special or punitive damages arising out of this Contract or any breach thereof, or any defect in, or failure of equipment or machinery, whether based upon loss of use, lost profits or revenue, interest, lost good will, work stoppage, impairment of other goods, loss by reason of shutdown or non-operation, increased expenses of operation, cost of purchase of replacement power or claims of Purchaser or customers of Purchaser for service interruption, whether or not such loss or damage is based on contract, warranty, negligence, indemnity, strict liability, or otherwise. **The total liability of the Company under this Contract in all other respects shall be limited to the purchase price of the services furnished hereunder.**





## Terms LD-147 International Service Supervisor

When KMT Waterjet Systems (hereinafter called the Company) provides the Services of a Service Supervisor (hereinafter called the Supervisor) to consult with and advise the Purchaser in the installation, starting up and/or overhaul or maintenance of equipment of KMT Waterjet manufacture, such Supervisor shall not be responsible for the procurement of labor or mechanical work performed by others. The Service Supervisor's services shall be furnished under the following conditions:

1. The Purchaser shall pay the Company for the services of said Supervisor per company service rates and terms in effect at the time the contracted work is complete. Any day the Supervisor is available for work and is denied access, with the exception of national holidays, will be invoiced eight (8) hours at the company service rate in effect on that day plus associated living expenses.

2. The Company shall also be reimbursed by the Purchaser for: (a) The Supervisor's transportation expenses en-route from the Company's facility or equivalent starting point to the jobsite and return thereto; (b) Any processing costs for passports, inoculations, etc., necessarily incurred in preparation for travel, as well as entry or exit fees, required to be paid as a result of such travel; (c) Subsistence and quarters for the Supervisor, comparable to those furnished the Purchaser's Superintendent. In the event the Purchaser shall decide to provide living accommodations to the Supervisor, such accommodations shall be equal to those provided for the Purchaser's Superintendent and shall not be less than the maximum accommodations furnished supervisory personnel of other contractors at Purchaser's jobsite; (d) Local transportation costs to and from the jobsite (taxi, auto rental, etc.); (e) All living expenses as detailed in (c) and (d) above for days where the supervisor has been denied access; (f) Transportation costs for any required special tools or equipment, plus costs for any of these items which are not returned to the Company at the completion of the services.

3. In the event that the Supervisor of the Company becomes obligated to pay any local taxes, levies, imposts, social charges, withholdings or duties of any nature, (hereinafter collectively called Taxes) as a result of services rendered herein, the Purchaser shall assume and pay such Taxes directly to the local tax authorities, or alternatively, immediately reimburse the Company for such Taxes, together with an amount which takes into account any Taxes due on account of a reimbursement including any taxes thereon. Purchaser shall pay any tax penalties or late charges which may be due in connection therewith. In the event the Purchaser pays such Taxes directly to the local tax authorities, it shall immediately furnish the Company with appropriate receipts evidencing such payment.

4. All necessary workmen (common, semi-skilled and skilled), together with proper labor supervision shall be furnished by the Purchaser, at his expense. All necessary utilities shall also be furnished by the Purchaser, at his expense. Qualified support labor must be made available to the Supervisor at all times during the Supervisor's work hours. **The Supervisor is prohibited by the Company from working alone.**

5. The Purchaser shall provide all tools and equipment required for any installation or service work. The Company's Supervisor may bring with him, or ship to the jobsite, special tools which are and shall remain Company property. If such tools are too heavy for transport by the Supervisor, the Purchaser shall assist in arranging for their return to a location designated by the Company at the completion of the services.

6. The Purchaser shall provide suitable office facilities convenient to the jobsite for work assignments exceeding thirty (30) days; facilities to include heat, light, desk, chair, telephone, and safe storage space for drawings and tools.

7. The Supervisor shall be properly covered with insurance in the areas of Worker's Compensation, Public Liability and Automobile Insurance where the use of a vehicle is required. Certificates confirming this insurance coverage are obtainable upon request. The Company shall in no event be liable for any loss recoverable by the Purchaser under insurance policies covering Purchaser's property.

8. The Company agrees that the Service Supervisor will provide Best Efforts in effecting repairs to equipment supplied by the Company, but provides no guarantee that such Best Efforts will result in restoration of proper operation of equipment the Service Supervisor is contracted to repair.

9. The Company accepts no responsibility for material or the acts of men furnished by the Purchaser. The Company is not responsible for the rate of progress or the date of completion of the work nor for incorrect operation or damage incurred due to improper storage or handling.

10. The Company shall be permitted to assign all or any portion of this Contract to a selected Professional Service organization without the prior consent of the Purchaser.

11. The Company reserves the right to replace a Service Supervisor after a 30 day period, in which event the Purchaser will pay to the Company associated expenses for the Supervisor's return trip. The replacement Supervisor will be furnished on the same basis as outlined herein.

12. If the services of a Supervisor are required for a period longer than six (6) months and the Company authorizes such Supervisor to be accompanied by members of his immediate family, the Purchaser will pay the Company for round trip expenses in connection with travel between the jobsite and the respective normal place of residence of such members of the immediate family of the Supervisor.

13. The Purchaser agrees that it will render all assistance to insure the Supervisor will be permitted prompt and safe exit from the country in which the services are performed.

14. The Company shall not be bound by or required to adhere to any term or provision of a purchase order, quotation, bid, letter of credit, or like document, or any provision of law, regulation or custom, which would cause the Company or any of its parents or affiliates to be in violation of the export laws, taxing statutes or regulations of the country of citizenship of the Supervisor or other country having jurisdiction over this contract.

15. The Company and its affiliates or suppliers shall in no event be liable to the Purchaser, any successors in interest or any beneficiary of this Contract for any consequential, incidental, indirect, special or punitive damages arising out of this Contract or any breach thereof, or any defect in, or failure of equipment or machinery, whether based upon loss of use, lost profits or revenue, interest, lost goodwill, work stoppage, impairment of other goods, loss by reason of shutdown or non-operation, increased expenses of operation, cost of purchase of replacement power or claims of Purchaser or customers of Purchaser for service interruption, whether or not such loss or damage is based on contract, warranty, negligence, indemnity, strict liability, or otherwise. **The total liability of the Company under this Contract in all other respects shall be limited to the purchase price of the services furnished hereunder.**



## SECTION 2

### INSTALLATION

#### 2.1 Overview

Installation and commissioning requirements and procedures are detailed in this section. These procedures require a thorough understanding of the individual components and systems, safety issues, and the overall operation of the intensifier.

All personnel involved in the installation, operation and/or service of the intensifier must carefully review this manual prior to installing and commissioning the machine.

The Technical Service Department at KMT Waterjet Systems is available to assist in the installation and commissioning process. Service and repair training for maintenance personnel is also available.

#### 2.2 Installation Summary

The following summary lists the procedures required for the installation and commissioning of the intensifier system. Details and requirements for each item are discussed in this section.

- Upon receipt, the machine must be uncrated and moved into position on a level surface.
- Properly sized power drops with fused disconnects must be installed.
- A pneumatic drop with a manual shutoff valve and regulator for the air connection must be installed.
- Plumbing and manual shutoff valves for the inlet and outlet cooling water, and the inlet and outlet cutting water must be installed.

Incoming source water must meet specific water quality standards, flow rates and pressure requirements. It may be necessary to install water conditioning and/or pressure boosting equipment to meet these water purity and pressure requirements.

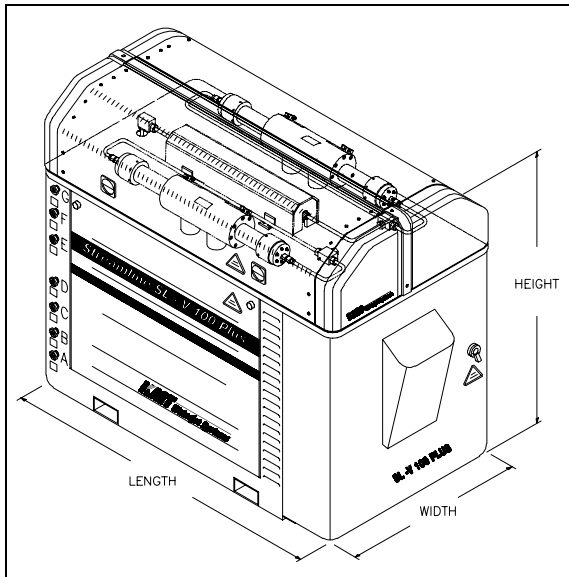
- Drain water plumbing must be suitably located and installed for the proper disposal of wastewater.
- High pressure tubing runs from the intensifier to the cutting station must be installed with the appropriate mountings, support brackets and hardware.
- Wiring must be installed and connected between the intensifier and the cutting station control system.
- The machine must be commissioned and tested.

### 2.3 Site Requirements

The intensifier must be installed indoors where air borne dust and contaminants are minimal. The ambient temperature should be between 40° F (5° C) and 104° F (40° C), with a maximum relative humidity of 95%.

Refer to Table 2-1, Equipment Dimensions and Weight, to establish a suitable installation site. A minimum clearance of 36 inches (914 mm) should be provided on all sides of the machine to facilitate service.

**Figure 2-1: Equipment Dimensions**



**Table 2-1  
Equipment Dimensions and Weight**

Horsepower	Length	Width	Height	Weight
100 HP	77.75" (1,975 mm)	36.00" (914 mm)	57.19" (1,453 mm)	4,200 lbs (1,905 kg)

### Transporting

The weight of the machine is not evenly distributed from one end to the other, particularly on the larger horsepower models. Do not attempt to lift the machine from either end. Note the warnings stamped on the crate. The center of gravity is clearly identified on the sides of the crate. The forklift should be positioned accordingly.

When the machine has been removed from the crate, note the position of the fork pockets on the bottom of the machine. The pockets are positioned in relationship to the center of gravity to balance the weight on the forklift.



Figure 2-2: Fork Pockets

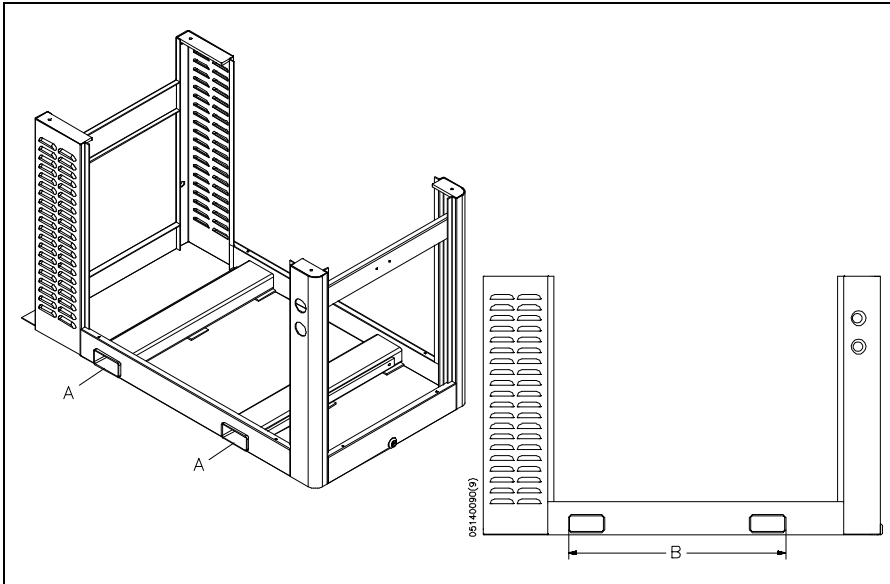


Table 2-2  
Fork Pockets

A	Fork Pocket Dimensions	
	Height	3.0" (76.2 mm)
	Width	8.0" (203.2 mm)
	Length	36.75" (933.45 mm)
B	Distance Between Pockets	36.0" (914.4 mm)

If the machine will be installed in an overhead location, a forklift or crane can be used to position the pump. Heavy straps or chains, properly rated for the weight requirements, should be placed through each fork pocket, and wrapped around the sides of the machine so they meet on the top. The straps can then be attached to a crane or forklift to lift the machine.



The machine **must** be lifted from the bottom. **Do not** attempt to lift the machine from the intensifier.

## 2.4 Power Requirements

Power supplied to the pump and wiring for remote control must comply with local, regional and national electrical codes. Service voltage and ampacity must meet the requirements of the specific model. Voltage fluctuations in excess of +/- 10 percent of nominal voltage may damage the machine and void the warranty. Refer to Table 2-3, Ampacity and Power Voltage Requirements.

**Table 2-3**  
**Ampacity and Power Voltage Requirements**

<b>Power Voltage</b>	<b>Motor Horsepower</b>	<b>Full Load Amps</b>	<b>Circuit Breaker Amps</b>
200/3/50	100	248	350
200/3/60	100	236	350
208/3/50	100	242	350
208/3/60	100	231	350
230/3/60	100	218	300
380/3/60	100	130	175
400/3/50	100	124	175
415/3/50	100	121	175
460/3/50	100	114	175
480/3/60	100	106	175
575/3/60	100	91	125

## 2.5 Service Connections

The intensifier requires two incoming water sources, cooling water and cutting water; three drain lines, cooling water, wastewater and contaminated waste; a high pressure discharge line, and an air supply line. All piping must comply with local, regional and national codes.

All service connections are made on the rear bulkhead of the machine as shown in Figure 2-3, Service Connections. Table 2-4 lists the fittings required and the height of each interface connection.

With the exception of the wastewater and contaminated waste drain lines, manual shutoff valves should be installed for all connections. To facilitate service, the valves should be located as close as practical to the interface connection.



Thoroughly purge all supply plumbing prior to connection to remove any residue that could contaminate the system.

Figure 2-3: Service Connections

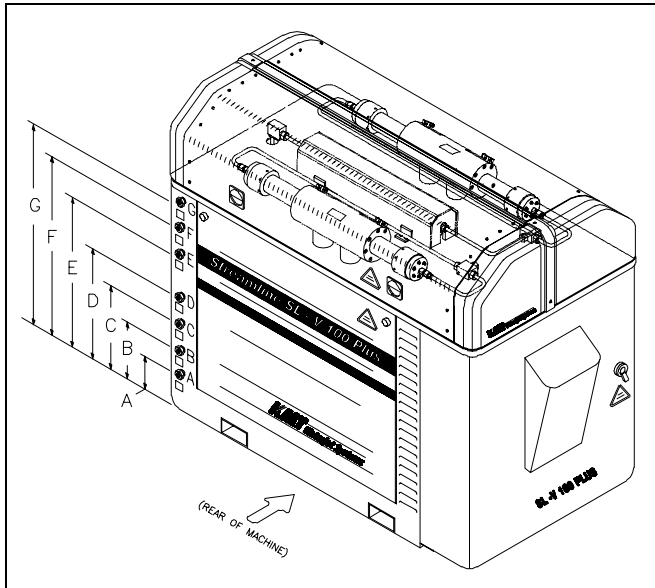


Table 2-4  
Service Connections

		Connection	Height
A	Drain	1/2" NPT	7.50" (191 mm)
B	Cutting Water In	1/2" NPT	10.50" (267 mm)
C	Cooling Water Out	1/2" NPT	13.50" (343 mm)
D	Cooling Water In	1/2" NPT	16.50" (419 mm)
E	Plant Air In	1/4" NPT	32.00" (813 mm)
F	Cutting Water Out	9/16" HP	36.00" (914 mm)
G	Contaminated Waste Drain	1/2" NPT	41.00" (1,041 mm)

### Cooling Water

Inlet cooling water flows through the oil-to-water heat exchanger in the hydraulic system to control heat build-up in the hydraulic oil. The cooling water is then discharged through the cooling water out port to either the drain or routed to a customer supplied water chiller.



Cooling water supply piping must be sized to meet the flow and pressure requirements of the specific equipment. If municipal or well water is used for cooling, ensure the supply flow and pressure meet the requirements provided in Section 11, Specifications.

If a facility-wide chilled water system is used for cooling, ensure there is a minimum of 35 psi (2.4 bar) pressure differential between the facility supply and discharge plumbing. Installation of an in-line pressure boosting pump may be necessary to provide adequate cooling flow.

### **Cutting Water**

Inlet cutting water is filtered and routed to the intensifier where it is pressurized and delivered to the cutting head. The cutting water supply must meet the minimum water quality standards outlined in Section 11, Specifications. Poor water quality will drastically shorten component life and void the warranty.

Cutting water supply piping must be sized to meet the flow and pressure requirements provided in Section 11, Specifications. Only PVC, copper or rubber hoses should be used between the cutting water source and the machine.

The inlet water must be maintained at a minimum pressure of 35 psi (2.4 bar) at all times. If the facility water pressure is below, or can fall below 35 psi (2.4 bar), a water pressure booster pump is required.

#### **NOTE**

The machine will not start if inlet cutting water pressure is below 30 psi (2 bar).

### **Drain**

Cutting water released through the safety dump valve when the emergency stop button is initiated is discharged from the drain port. The discharge is considered wastewater and must be piped to an appropriate location, i.e. a sewer line. The volume of water released will be minimal and does not require high pressure plumbing, however, piping must comply with local, regional and national codes.

### **Plant Air**

The facility compressed air connection should provide clean, dry air regulated to 85 psi (5.9 bar). Air usage is minimal, normally less than 1 scf/m. An inline check valve prevents equipment damage if the air supply to the pump is interrupted.

### **Contaminated Waste Drain**

Oil and water that can accumulate on the top pan is disposed of through the contaminated waste drain port. This oil and water mixture is considered contaminated and disposal must comply with local, regional and national codes. The volume of waste will be minimal and can be collected in a container of some appropriate type.

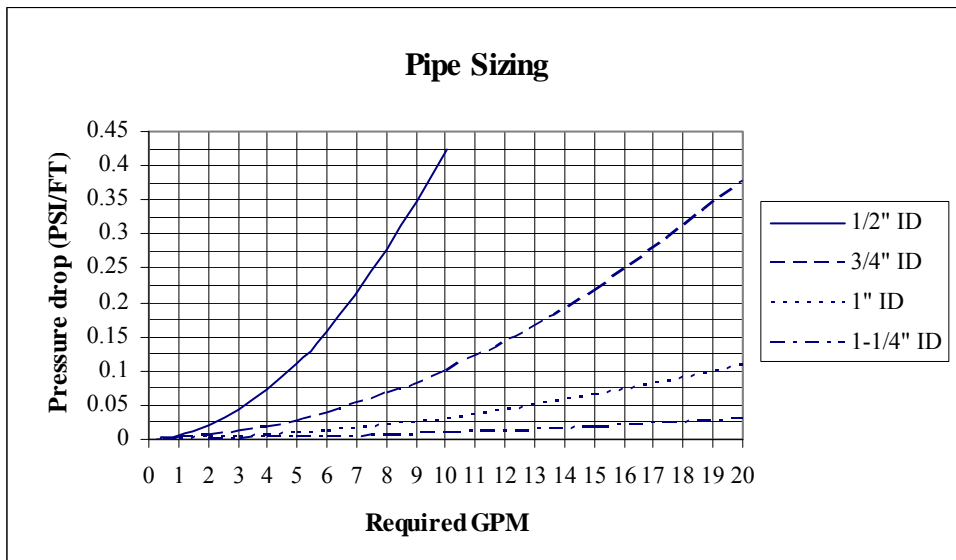
## 2.6 Flow Requirements

Figure 2-4, Pressure Drop Values, illustrates the pressure drop for four different pipe sizes. The graph can be used to calculate the minimum source water pressure.

1. Enter the graph at the required GPM and note the pressure drop figures for the different pipe sizes.
2. Multiply the pressure drop (PSI/FT) by the length in feet of each pipe size used from the water source to the intensifier. Add the values together for a total pressure drop value.
3. Add 30 to the total pressure drop to determine the minimum flowing, source water pressure required to provide adequate supply to the intensifier.

Cutting water and cooling water capacity should be calculated separately. Note that the cutting water requirements represent instantaneous, not average, demand. **The machine will not start if the inlet cutting water pressure drops below 30 psi (2 bar).**

Figure 2-4: Pressure Drop Values



## 2.7 High Pressure Piping

High pressure piping is used to transport high pressure cutting water from the machine to the cutting station. High pressure piping and fittings must be properly rated and sized. When transporting high pressure water over long distances, tubing and fittings with an outside diameter of 9/16-inch are recommended. The large tubing size reduces vibration, strain and motion; as well as reducing pressure drop and pulsation.



High pressure tubing and fittings must be rated for 60,000 psi (4,136 bar). Failure to use properly rated components may result in component failure causing equipment damage, personal injury or death.

High pressure tubing lengths must be coned and threaded prior to installation. KMT Waterjet provides both hand and power tools for coning and threading high pressure tubing. Tool descriptions and part numbers are provided in Table 2-5.

**Table 2-5**  
**Coning and Threading Tools**

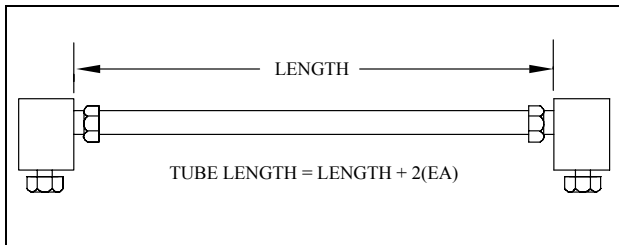
	Part Number	
	Hand Tools	Power Tools
1/4" Coning Tool	05108832	05109897
3/8" Coning Tool	05108857	05109889
9/16" Coning Tool	05108840	05109871
1/4" Threading Tool	05108865	05122742
3/8" Threading Tool	05108873	05120258
9/16" Threading Tool	05108881	05122759
1/4" Tube Vise	05108782	
3/8" Tube Vise	05108790	
9/16" Tube Vise	05108774	

### Measurements and Dimensions

Tubing must be cut to the proper length, both ends of the tubing must then be coned, threaded and deburred.

To determine the tube length, measure the distance between the fittings, and add two times the engagement allowance shown in Table 2-6. Table 2-7 lists the required cone and thread dimensions illustrated in Figure 2-6.

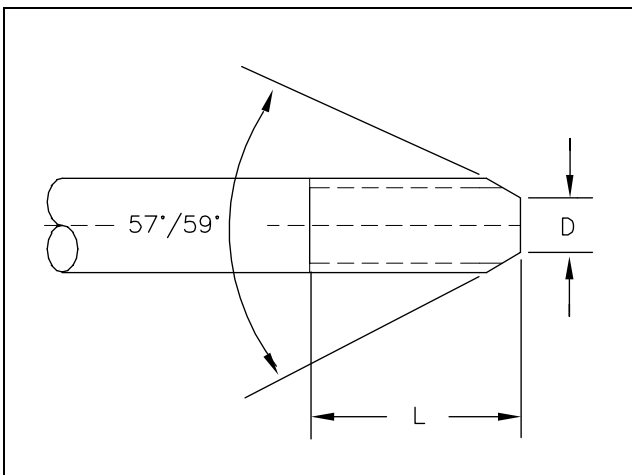
**Figure 2-5: Tube Length**



**Table 2-6  
Engagement Allowance (EA)**

1/4" Tubing	0.49" (12.4 mm)
3/8" Tubing	0.68" (17.3 mm)
9/16" Tubing	0.86" (21.8 mm)

**Figure 2-6: Cone and Thread Dimensions**

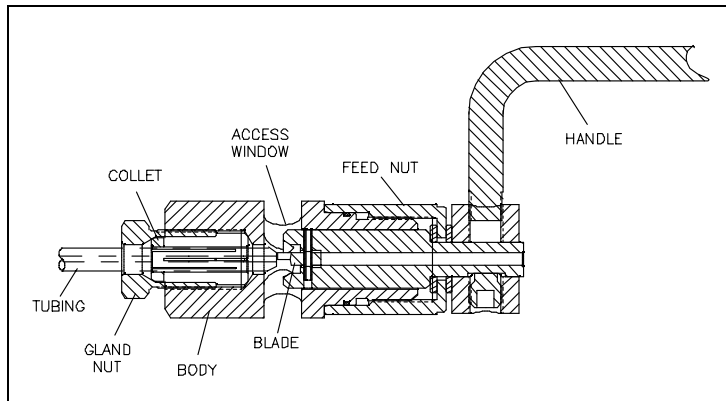


**Table 2-7  
Cone and Thread Dimensions**

Tube OD	Tube ID	D (Maximum)	L (Maximum)	Thread UNF-LH
1/4" (6.35 mm)	0.083" (2.11 mm)	0.125" (3.2 mm)	0.562" (14.3 mm)	1/4" - 28
3/8" (9.52 mm)	0.125" (3.18 mm)	0.219" (5.6 mm)	0.750" (19.1 mm)	3/8" - 24
9/16" (14.29 mm)	0.188" (4.78 mm)	0.281" (7.1 mm)	0.938" (23.8 mm)	9/16" - 18

## Hand Coning

**Figure 2-7: Hand Coning Tool**



1. Place the body of the coning tool in a vise allowing adequate clearance for the rotation of the cutter handle. Position the tool so the cutter handle is elevated slightly so the lubricant will flow to the cutting blade.
2. Turn the feed nut counter-clockwise to retract the cutting blade past the access window.
3. Loosen the gland nut and insert the tubing through the collet. The end of the tubing should just make contact with the cutting blade. Loosely tighten the gland nut to slightly grip the tubing.
4. Turn the feed nut counter-clockwise 1/4 turn to retract the cutting blade away from the tubing, and tighten the gland nut with a wrench.
5. Apply a liberal amount of cutting oil to the exposed end of the tubing, the cutting blade and through the lubrication channel at the cutter handle.

Apply cutting oil frequently and liberally throughout the cutting operation. A medium weight cutting oil with high sulfur content is recommended.

6. Turn the feed nut clockwise until the cutting blade contacts the end of the tubing.
7. In a smooth, continuous motion, turn the cutter handle in a clockwise direction. Simultaneously turn the feed nut in a clockwise direction to establish a constant feed. Do not remove too much material at once; the cutting blade should make light, uninterrupted cuts.



**NOTE**

Before interrupting the cut, back the cutter blade away from the tubing. Use compressed air or a small brush to remove the accumulation of chips from the blades and the tubing throughout the coning operation.

8. Continue the operation until the feed nut bottoms on the housing. Turn the cutter handle several more rotations to face-off the end of the cone.
9. Retract the cutter blade, loosen the gland nut and remove the tubing. Inspect the cone for surface finish and completeness.

**NOTE**

Clean the machining chips from the blade and from the collet before coning the next tube.

### Power Coning

1. Secure the tubing in a tube vise. No more than the recommended length of tubing should extend beyond the face of the vice. See Table 2-8, Recommended Extension Length.
2. Mount the coning tool in a 3/8-inch or 1/2-inch, variable speed power drill. Apply cutting oil to the end of the tube and slide the coning tool on the tubing.
3. Apply steady pressure against the end of the tubing while the cone is being cut.

Apply cutting oil frequently and liberally throughout the cutting operation. A medium weight cutting oil with high sulfur content is recommended.

4. The tool will stop cutting when the tube angle and facing is complete.

**NOTE**

Clean the machining chips from the blade and body of the tool before coning the next tube.

**Table 2-8**  
**Recommended Extension Length**

1/4" Tubing	1.25-1.50" (31.8-38.1 mm)
3/8" Tubing	1.25-1.50" (31.8-38.1 mm)
9/16" Tubing	1.75-2.00" (44.5-50.8 mm)

### Hand Threading

1. Secure the coned tubing in a tube vise. No more than the recommended length of tubing should extend beyond the face of the vice. See Table 2-8, Recommended Extension Length.
2. Apply cutting oil to the end of the tube and slide the threading tool on the tubing.
3. Grip the handle of the tool firmly, apply steady pressure and turn the tool counter-clockwise. Approximately every half turn, reverse direction to break off and remove the chips.

Apply cutting oil frequently and liberally throughout the cutting operation. A medium weight cutting oil with high sulfur content is recommended.

4. Continue threading until the proper thread length is reached, see Table 2-7, Column L. Remove the tool from the end of the tubing.

#### NOTE

Clean the machining chips from the die and body of the tool before threading the next tube.

### Power Threading

1. Secure the coned tubing in a tube vise. No more than the recommended length of tubing should extend beyond the face of the vice. See Table 2-8, Recommended Extension Length.
2. Mount the threading tool in a 3/8-inch or 1/2-inch, variable speed power drill. Apply cutting oil to the end of the tube and slide the threading tool on the tubing.
3. Make sure the drill is set to turn counter-clockwise. Apply steady pressure against the end of the tubing while the threads are being cut.

Apply cutting oil frequently and liberally throughout the cutting operation. A medium weight cutting oil with high sulfur content is recommended.

- Continue threading until the proper thread length is reached, see Table 2-7, Column L. Reverse the direction of the drill and remove the threading tool.

**NOTE**

Clean the machining chips from the die and body of the tool before threading the next tube.

## 2.8 High Pressure Connections

When installing high pressure discharge piping it is essential that all burrs be carefully removed and the tubing sections purged with clean compressed air prior to assembly. Lightly spraying the inside of the tube with a carrier fluid, such as WD-40, before purging with air will help carry the burrs.

High pressure piping must be installed without torsional or bending stresses and proper supports and guides must be provided. Torsional stress will cause premature component failure.

Pure Goop anti-seize compound must be applied to the threads and contact surfaces of all stainless steel components prior to assembly. Failure to lubricate components with Pure Goop will result in galling, rendering the components useless.

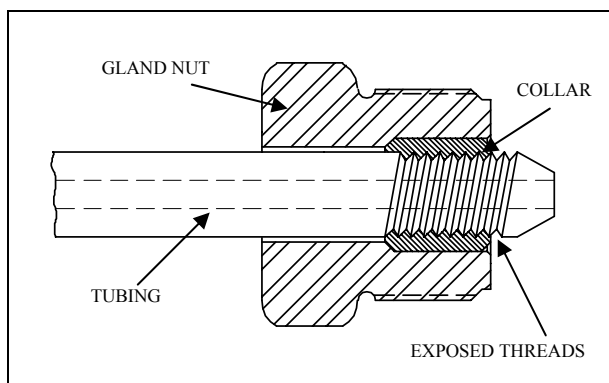


**Do not** use any other anti-seize compound. Apply Pure Goop **only to stainless steel** components.

### Standard Connections

Standard connections are used for general applications where internal pressure is the only load on the tubing.

*Figure 2-8: Standard High Pressure Connections*



1. Deburr the tubing ID and thoroughly clean the tubing threads.
2. Slip the gland nut onto the tubing.
3. Apply Pure Goop to the threads on the tubing. Screw the collar onto the threaded end of the tubing leaving 1-1/2 to 2-1/2 threads exposed on the tubing between the collar and the coned tubing.
4. Apply Pure Goop to the male threads on the gland nut and insert the tubing into the connection. Engage the gland nut and tighten finger tight.
5. Tighten the gland nut to the torque specifications in Table 2-9.



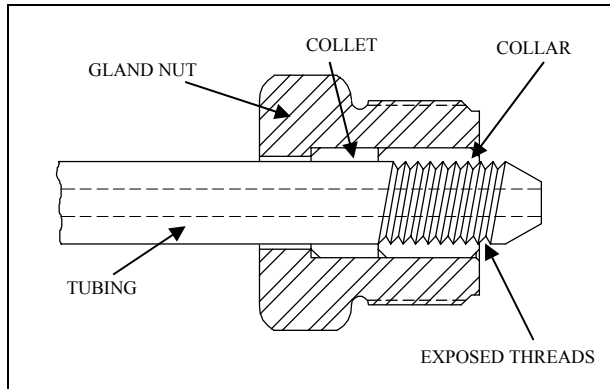
Proper piping supports and guides must be provided. End connections will not support the tubing load alone.

**Table 2-9**  
**Torque Specifications**  
**High Pressure Connections**

1/4" Tubing	25 ft-lb (34 Nm)
3/8" Tubing	50 ft-lb (68 Nm)
9/16" Tubing	110 ft-lb (149 Nm)

### **Anti-Vibration Connections**

The bending stresses resulting from excessive vibration or shock on the threaded area of the tubing can cause premature failure at the back of the thread. When tubing will be subjected to vibration, rotation and movement, anti-vibration connections must be used. The anti-vibration collet gland transfers the stress to the unthreaded section of the tubing, and the gripping action of the collet strengthens the entire assembly.

**Figure 2-9: Anti-Vibration Connections**

1. Deburr the tubing ID and thoroughly clean the tubing threads.
2. Slip the gland nut and the collet onto the tubing.
3. Apply Pure Goop to the threads on the tubing. Screw the collar onto the threaded end of the tubing leaving 1-1/2 to 2-1/2 threads exposed on the tubing between the collar and the coned tubing.
4. Apply Pure Goop to the male threads on the gland nut and insert the tubing into the connection. Engage the gland nut and tighten finger tight.
5. Tighten the gland nut to the torque specifications in Table 2-9.

When a flexible whip is used to allow cutting nozzle movement, anti-vibration fittings and proper supports and guides must be provided to prevent failures from non-water related stresses. The whip will only flex in a single plane without being subjected to torsional stress. The use of high pressure swivels is strongly recommended.

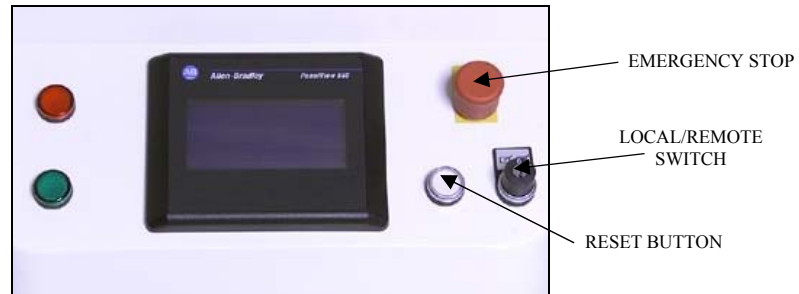
## 2.9 Commissioning

When the machine has been positioned, all service connections installed, and the high pressure plumbing has been installed to the cutting area, the machine is ready to be commissioned.

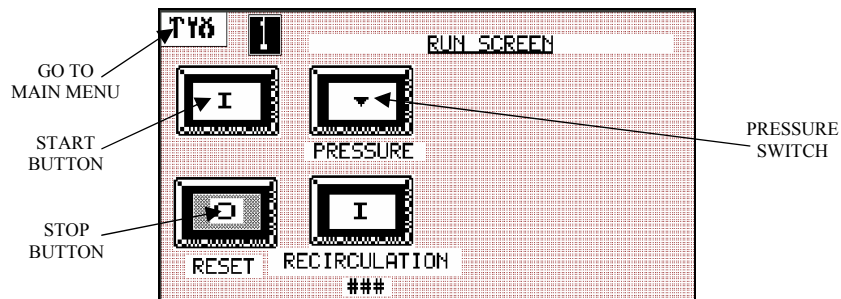
The following procedure is used for the initial startup and testing of the machine.

1. Check all areas in and around the pump for foreign objects and debris. Remove all tools, parts, etc. from the area.
2. Check the hydraulic fluid level. The hydraulic system is pre-filled prior to shipping. If the hydraulic fluid is low or empty due to leakage during transit, the system must be filled. Follow the instructions and specifications in Section 6, Recirculation System.
3. Open the shutoff valves on the service connections and check for leaks.

4. Check the connection between the main power disconnect and the disconnect/circuit break on the enclosure door. Verify the proper voltage supply. Close the enclosure door and turn the control power on.
5. To activate the control panel display, pull the EMERGENCY STOP button out and press the RESET button. The control panel will go through a series of diagnostics, and the Run Screen will display. Refer to Section 4, Operation, for additional information regarding control panel functions.

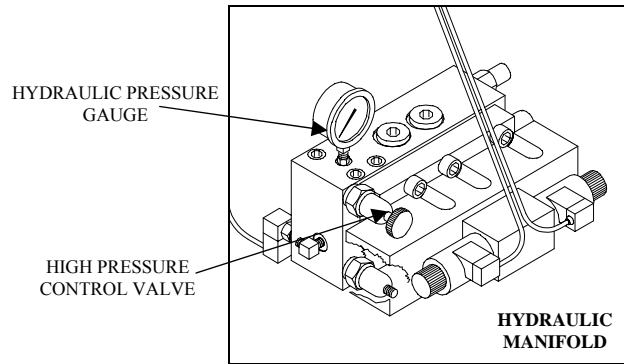


6. On the Run Screen, select the ▼ arrow on the PRESSURE switch to select low pressure operation.



7. To avoid a sudden increase in pressure, it is necessary to adjust the high pressure setting. On standard machines, the high pressure adjustment is made at the high pressure control valve on the hydraulic manifold. Refer to Section 7, Hydraulic System, for additional information.

Loosen the locking nut on the high pressure control valve by turning counter-clockwise. Turn the high pressure control valve counter-clockwise, decreasing the pressure to the lowest setting.



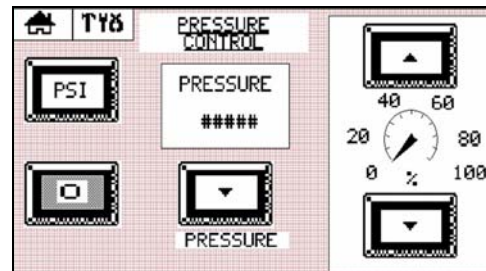
If the machine is equipped with proportional pressure control, the high pressure adjustment is made from the Pressure Control Screen on the control panel. Refer to Section 4, Operation, for additional information.

From the Run Screen, press the tool icon to go to the Main Menu. Select Pressure Control to display the Pressure Control Screen. The dial on the right of the Pressure Control Screen indicates the high pressure setting. Press the ▼ arrow to set the pressure to zero.

*Main Menu*



*Pressure Control Screen*



8. Check the motor rotation. Press the START button on the Run Screen and observe the pressure gauge on the hydraulic manifold. If the motor rotation is correct, pressure will begin to build in just a few seconds. If the rotation is not correct, the gauge will not move.

If the motor shaft is rotating in the wrong direction, press the STOP button and turn the control power off by pressing the EMERGENCY STOP button.

The electrical power phase must be reversed to any two motor leads. The leads can be reversed at the disconnect/circuit breaker on the enclosure door, or at the main power disconnect.

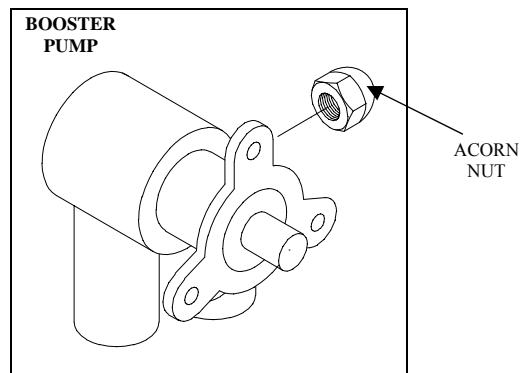


**Do not** allow the motor to run backward. Incorrect motor rotation will result in damage to the hydraulic pump.

9. Remove the cutting orifice and open the nozzle valve.

10. Activate the control power and press the START button to start the motor. The dump valve will open for a short time to allow trapped air to bleed from the high pressure cylinders. Run the machine in low pressure for approximately five minutes with the orifice removed to purge the system.
11. Check for any leaks in the plumbing, or around the high pressure cylinders. If leaks are detected, stop the machine and correct any problems.
12. Observe the Booster Pressure Gauge on the front of the machine to ensure the boosted water pressure peaks between 90-120 psi (6-8 bar) while the intensifier is stroking. If not, the booster pump pressure must be adjusted. Refer to Section 5, Low Pressure Water System, for additional information.

Remove the acorn nut on the side of the booster pump and use a flat blade screwdriver to turn the adjustment screw. Turn the screw clockwise to increase the pressure or counter-clockwise to decrease the pressure.



13. Check the safety circuits by pushing the EMERGENCY STOP button in and verifying that the power goes off and high pressure water is drained from the system. If applicable, check all remote start and emergency stop functions.
14. Install a large, inexpensive orifice and start the machine.
15. On the Run Screen, select the ▲ arrow on the PRESSURE switch to select high pressure operation. Increase the high pressure setting in gradual increments, checking for leaks at each interval. Continue increasing the pressure until the operating pressure is reached.

The high pressure setting is increased by turning the high pressure control valve on the hydraulic manifold clockwise, or by pressing the ▲ arrow on the Pressure Control Screen.

#### **NOTE**

It is strongly recommended that the high pressure plumbing be purged under high pressure operating conditions, using a large, inexpensive orifice. Contamination can be released when the tubing expands under pressure. Early orifice failures could be experienced if the piping is not adequately purged





## **2.10 Decommissioning**

All local regulations must be adhered to when the intensifier is decommissioned and taken out of service for any reason.



## SECTION 3

### MAINTENANCE

#### 3.1 Overview

The SL-V SRP 100 intensifier has been designed to fail safely. Systems fail gradually; seals and connections begin to leak slowly or suddenly through specially designed weep holes. Water or oil dripping from a weep hole indicates internal seals or valves are beginning to fail, a warning that maintenance will be required.

The comprehensive fault detection and troubleshooting logic built into the programmable logic controller (PLC) monitors crucial pressure, temperature and fluid levels. Warning and shutdown sensors guard against potential injury and equipment damage.

#### 3.2 Maintenance

The waterjet system has been designed for ease of maintenance and long, reliable operation. In order to keep the equipment in optimum operating condition, routine and preventive maintenance is essential. Detailed maintenance and troubleshooting procedures for specific systems are provided in subsequent sections of this manual.

##### Daily Inspection

The following inspection procedures should be performed each day. If problems are detected, they should be remedied before placing the machine in service.

- Prior to startup, inspect the area around the machine, the high pressure piping and connections for indications of leaks.
  - Make sure there is no maintenance work in process.
  - Check the hydraulic oil level.
- As the machine is started and water pressure increases, listen for unusual sounds.
  - Check for water or oil leakage.
  - Check the condition of the water filter and the oil filter.

##### Periodic Maintenance

A number of factors can contribute to component failure; poor water quality, operating conditions, or improper maintenance procedures. Maintaining a service log can be a useful method of tracking component life and maintenance trends. Analyzing service intervals will assist in preparing a preventive maintenance schedule tailored to your specific application and



production requirements. Periodic maintenance, at regularly scheduled intervals, will minimize unscheduled downtime and premature component failure.

Improper assembly can lead to the premature failure of components. Maintenance procedures must be followed carefully; components must be properly cleaned prior to assembly and tightened to the correct torque specifications.

- Maintain a clean, dust and dirt free work area for maintenance.
- Use only clean, dry air and clean, filtered solvent when flushing parts.
- Use lint free cloths for cleaning.
- Use extreme care when aligning close tolerance parts for assembly. Do not force the parts together. If parts bind during assembly, they must be disassembled and re-aligned.
- Use only original KMT Waterjet replacement parts for consistent performance and reliability; and to protect equipment warranty.

To avoid unsafe conditions and the risk of equipment damage, operating personnel and service technicians must carefully read and follow the procedures in this manual.

### **High Pressure System Maintenance**

The high pressure system is conveniently mounted on a drip pan. All service components are readily accessible, and can be removed from the unit easily for maintenance and service.

- High pressure fittings, valves and tubing must be rated for 60,000 psi (4,137 bar). Failure to use properly rated components may result in component failure, equipment damage and personal injury.
- Do not over-torque fittings to stop leakage.
- Ensure all components are clean, free of burrs, metal particles, dirt and dust prior to assembly.

After servicing high pressure components the high pressure water system must be thoroughly flushed to remove any debris or contaminants.

1. Operate the intensifier for a short period with the nozzle valve open and the orifice removed.
2. Turn the intensifier off and install an orifice.
3. Turn the machine on and increase the operating pressure in gradual increments. Check all high pressure connections for leaks.

Many components are lubricated prior to assembly. Table 3-1 lists the recommended lubricants and their applications. Substitutions are not recommended.

**Table 3-1**  
**Lubrication Specifications**

<b>Description</b>	<b>Application</b>	<b>Part Number</b>
Pure Goop	Stainless steel threads	10084440
FML-2 Grease	O-rings, backup rings, bearing rings, seal components	10087385
JL-M Grease	Non-stainless steel threads	49832199

### 3.3 Maintenance Precautions

Make sure all safety devices are operational. Each device should be checked on a specified schedule. If the device does not function, it must be replaced before operating the machine.

Check the EMERGENCY STOP button. The normal operating position is pulled out. Turn the power on and activate the emergency stop button by pushing it in to verify the power goes off and the safety dump valve opens to bleed the high pressure from the system.

Before performing any maintenance on the equipment, take the system out of service and make sure the controls are properly locked and marked. Never perform any maintenance on the equipment without making sure the main control power is locked out in the OFF position.

- **Never** service or maintain the equipment while it is operating.
- Steam or fog inside the top cover is an indication of a high pressure leak. All high pressure leaks must be repaired immediately. Press the EMERGENCY STOP button to turn the control power off and bleed off the high pressure water from the intensifier **before** lifting the cover.
- Never service or maintain any high pressure component, or loosen any high pressure fitting when it is pressurized. Press the EMERGENCY STOP button to turn the control power off and bleed off the high pressure water from the intensifier before servicing.
- If leakage occurs at a sealing surface, high pressure water is released through weep holes. If a pressurized fitting is loosened, a jet of high pressure water will exit the nearest weep hole with **possible hazardous results**.



## SECTION 4 OPERATION

### 4.1 Overview

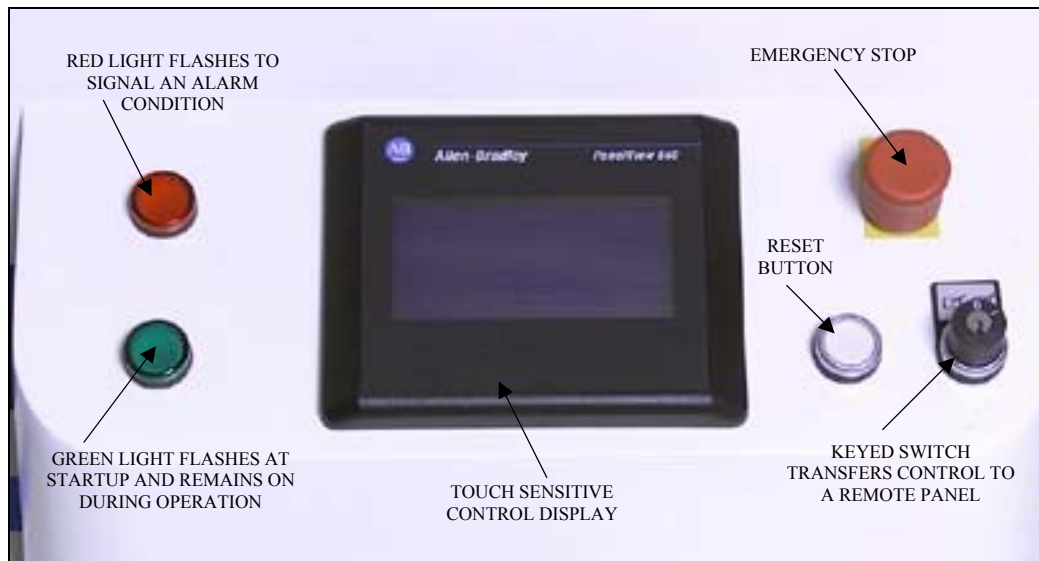
The SL-V SRP 100 intensifier utilizes a programmable logic controller (PLC) to provide comprehensive fault detection and troubleshooting logic. The operator functions and warnings offer a comprehensive view of operating conditions, impending faults, shutdown faults and suggested remedies.

Remote monitoring of the PLC is available as an option. A modem interface allows KMT Waterjet to access to the machine's PLC program. The KMT Customer Service Department can perform real time diagnostics, remote troubleshooting, data analysis and software updates.

The operator interface is through a touch sensitive control display where operating parameters are set and monitored. Optional proportional pressure control allows the operator to select or vary the operating pressure from the control display or from a remote console. When the machine is equipped with an optional pressure transducer the operating pressure can be viewed from the display. Analog modules for the PLC are required to operate both of these options.

Figure 4-1 identifies the control panel components and functions.

**Figure 4-1: Control Panel**



## **4.2 Startup Sequence**

The startup sequence varies depending on the previous stop condition, and whether the machine is equipped with the optional pressure transducer.

### **Startup after Motor Stop**

After a normal motor stop the safety dump valve will be closed and high pressure will be present in the intensifier. Press the **START** button on the Run Screen to start the motor. The machine will be held in low pressure for 5-60 seconds as determined by the operator, it then goes to high pressure or remains in low pressure, depending on the previous pressure setting on the Run Screen.

If the machine is equipped with a pressure transducer and pressure is not allowed to bleed, the startup sequence is the same as above.

If the machine is equipped with a pressure transducer and pressure is allowed to bleed through the orifice to below 1,000 psi (69 bar), the dump valve will open. In this case, the startup sequence is as described below.

### **Startup after Emergency Stop**


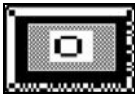




After an emergency stop the safety dump valve will be open and high pressure released in the intensifier. The dump valve will close three seconds after the intensifier begins to stroke.

Pull the **E-STOP** button out and push the **RESET** button to activate the control display. Press the **START** button on the Run Screen to start the motor. The machine will be held in low pressure for 5-60 seconds as determined by the operator, to allow trapped air to bleed from the high pressure cylinders. It then goes to high pressure or remains in low pressure, depending on the previous pressure setting on the Run Screen.

### 4.3 Display Controls

Table 4-1 illustrates controls common to all displays.

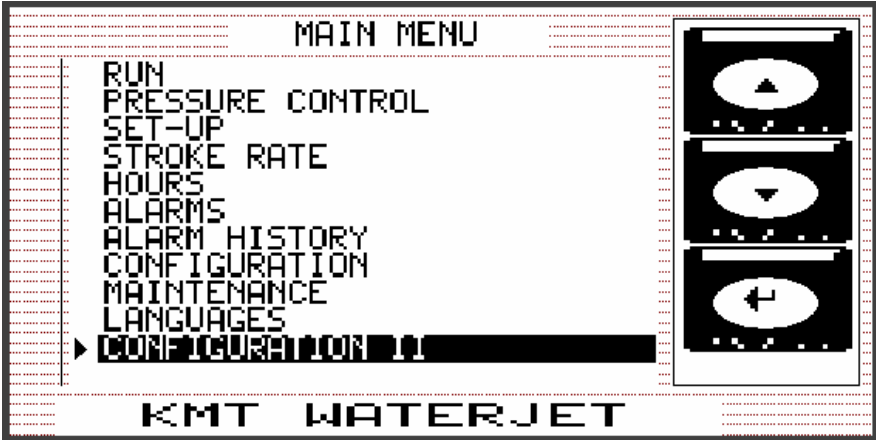
**Table 4-1**  
**Display Controls**

<b>Control</b>	<b>Function</b>	<b>Comments</b>
	START The START button only displays on the Run and Maintenance Screens	The Run Screen is the only location where the machine can be started to create pressure.  The machine must be started from the Maintenance Screen to access maintenance functions. The machine will start in recirculation mode.
	STOP The STOP button displays on all screens except the Alarm History and Language Screens	Motor stop only, the control power remains on
	Return to Main Menu	
	Return to Run Screen	
	ON position for controls on the Set-Up Screens	Enables function
	OFF position for controls on the Set-Up Screens	Disables function

### 4.4 Main Menu

The Main Menu provides a list of available setup and monitoring screens. Press the ▲ or ▼ arrow to highlight the desired screen. Press ENTER (↵) to display the selected screen.

Figure 4-2: Main Menu



### 4.5 Run Screens

The Run Screen is the only location where the machine can be started to create pressure. After five minutes on any other screen, the display will default to the Run Screen.

Run screens are configured according to equipment options. If machines are connected to a header system that is controlled by the KMT Waterjet Balancing System, a number displays in the black box on the top of the Run Screen to indicate the machine's position within the system.

Figure 4-3: Run Screen - Standard Machine

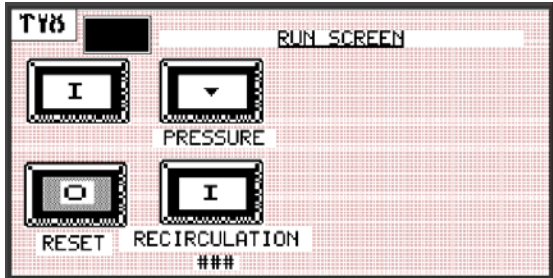
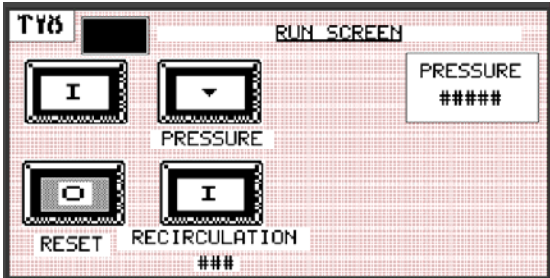


Figure 4-4: Run Screen - Pressure Transducer





The Run Screen displays the following functions:

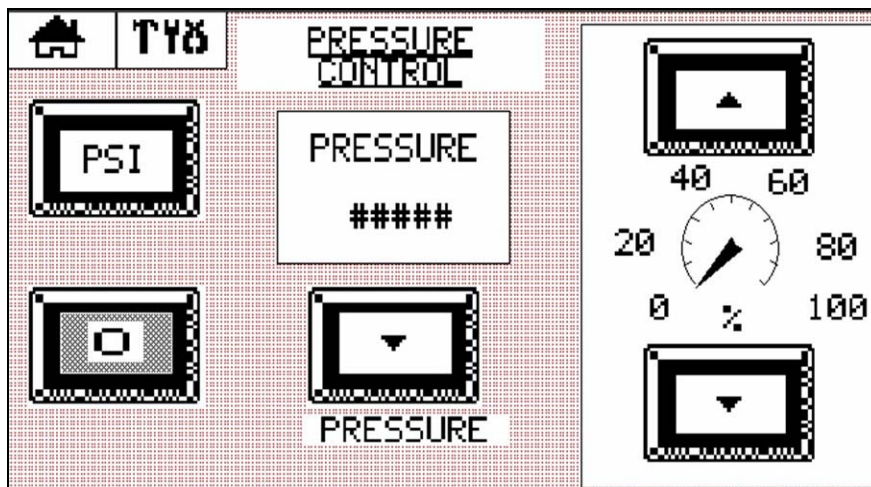
- START button flashes when the machine is ready to start. After the machine has been stopped, there is a five-second delay before startup.
- STOP button flashes to indicate the machine is on and can be stopped by pressing this button
- RESET is the inlet water solenoid indicator. The inlet water solenoid valve is automatically closed five minutes after the machine shuts down. When it flashes, press the STOP button to reset and open the valve. This function can be disabled on the Set-Up Screen
- PRESSURE switch; press the ▲ or ▼ arrow to select high or low pressure. When stopped and restarted the machine will always start in low pressure. After 5-60 seconds, depending on the interval selected by the operator, it will go to high pressure or remain in low pressure, depending on the previous high/low pressure setting.
- RECIRCULATION switch; select the ON position to recirculate the machine. The machine will recirculate for 10 minutes before the switch shuts off. Recirculation can be manually stopped by pressing the STOP button. Recirculation time is indicated below the switch.

The Run Screen in Figure 4-4 will display if the machine is equipped with a pressure transducer. The PRESSURE indicator displays the output pressure in either psi or bar, depending on the selection made on the Setup Screen.

## 4.6 Pressure Control Screen

The Pressure Control Screen displays if the machine is equipped with the optional proportional pressure control. If Pressure Control is selected on the Main Menu and the machine is not equipped with this option, a message screen displays prompting THIS UNIT IS NOT EQUIPPED WITH PROPORTIONAL PRESSURE CONTROL.

Figure 4-5: Pressure Control Screen



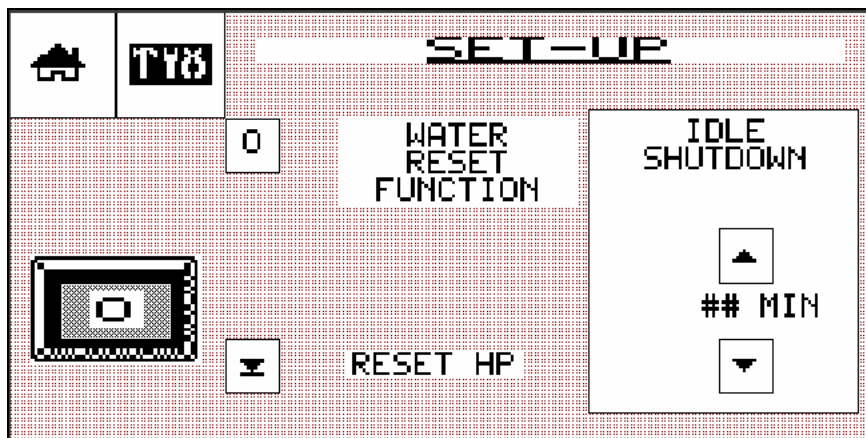
The Pressure Control screen in Figure 4-5 displays the following functions:

- PSI/BAR selector changes the pressure display on the Run Screen and the Pressure Control Screen; press to display output pressure as psi or bar
- STOP button flashes to indicate the machine is on and can be stopped by pressing this button
- PRESSURE indicator displays the output pressure. The PRESSURE indicator will not display if the machine is not equipped with the optional pressure transducer.
- PRESSURE switch; the ▲ or ▼ arrow indicates high or low pressure
- PROPORTIONAL PRESSURE CONTROL; increment/decrement pressure allows the pressure to be set in 1% increments; press the ▲ or ▼ arrow to set the pressure from 0 to 100%

## 4.7 Setup Screens

Setup screens are configured for the specific machine, displaying only the available functions.

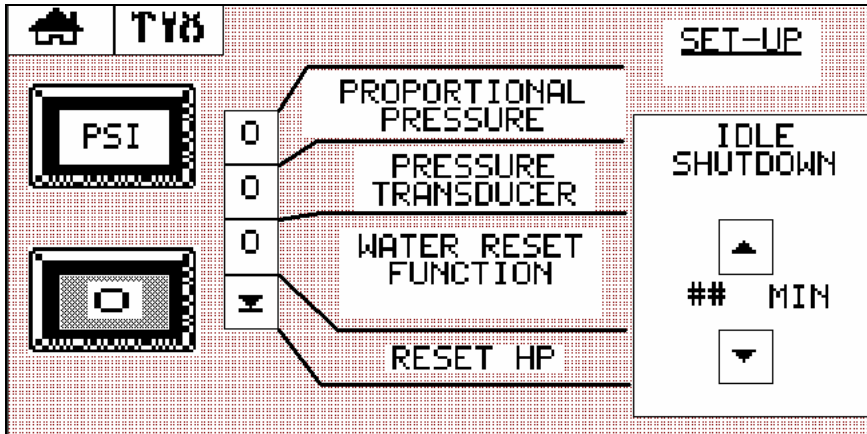
*Figure 4-6: Setup Screen - Standard Machine*



The Setup Screen for a standard machine displays the following functions:

- WATER RESET FUNCTION automatically shuts the inlet water solenoid valve five minutes after the machine shuts down; press the control to turn it ON or OFF
- RESET HP is only pressed when a new version of the display program is installed
- IDLE SHUTDOWN automatically stops the motor after a deadhead condition occurs; press the ▲ or ▼ arrow to select an idle time from 5-60 minutes

Figure 4-7: Setup Screen - Pressure Transducer and Proportional Pressure Control Options



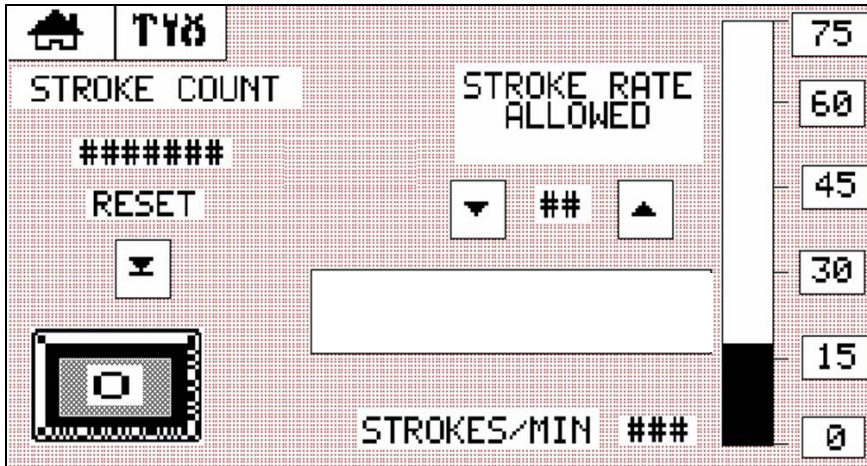
The Setup Screen in Figure 4-7 and the following functions will display if the machine is equipped with analog control modules:

- PSI/BAR selector changes the pressure display on the Run Screen and the Pressure Control Screen, if applicable; press the button to display output pressure as psi or bar. Recalibration of the transducer is automatic and does not require operator input.
- PROPORTIONAL PRESSURE allows the output pressure to be set from the Pressure Control Screen; press the control to turn it ON or OFF
- PRESSURE TRANSDUCER displays the output pressure on the Run Screen and the Pressure Control Screen, if applicable; press the control to turn it ON or OFF
- WATER RESET FUNCTION automatically shuts the inlet water solenoid valve five minutes after the machine shuts down; press the control to turn it ON or OFF
- RESET HP is only pressed when a new version of the display program is installed
- IDLE SHUTDOWN automatically stops the motor after a deadhead condition occurs; press the ▲ or ▼ arrow to select an idle time from 5-60 minutes

## 4.8 Stroke Rate Screen

The graph on the right side of the Stroke Rate Screen monitors the real time strokes per minute.

Figure 4-8: Stroke Rate Screen



- STROKE COUNT displays the total number of strokes since the count was reset
- RESET the stroke count by pressing the ▼ arrow button
- STROKES/MIN displays the actual strokes per minute
- STROKE RATE ALLOWED increases or decreases the allowed stroke rate; press the ▲ or ▼ arrow to select the rate.

Stroke rate should be set slightly higher than the desired operating rate to shutdown the machine quickly in the event of an overstroke condition. The upper limit stroke rate for the SL-V SRP 100 is preset at 61 strokes per minute. Table 4-2, Overstroke Set Points, shows the number of strokes per minute above the setting that will result in a warning or shutdown condition.

Before setting the stroke rate you can monitor the graph to assess the actual stroke rate during normal operation. The stroke rate allowed should then be set 20% above that rate.

**Table 4-2  
Overstroke Set Points**

Horsepower	Maximum Limit	Strokes Per Minute Added to Stroke Rate Allowed	
	35,000 psi	Warning	Shutdown
100	61	3	6

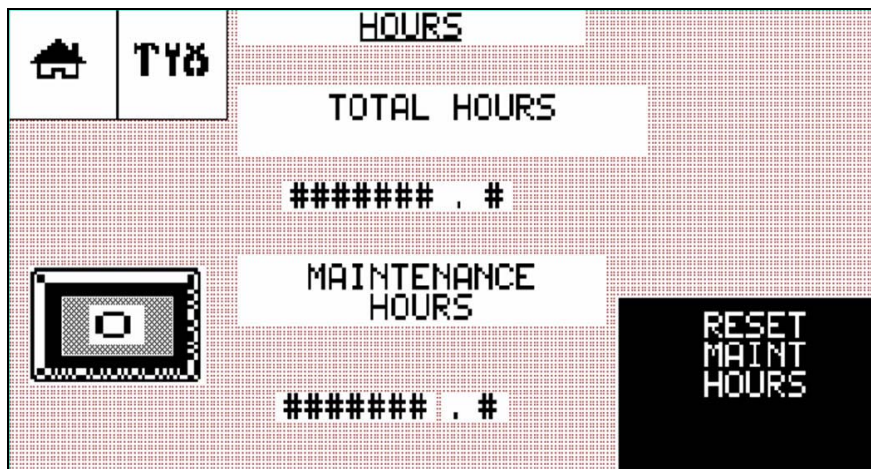
**Example** The allowable stroke rate is set at 40 strokes per minute. If the stroke rate reaches 43, an overstroke warning will be issued after 15 seconds. The warning will continue until the rate returns to normal, or exceeds the overstroke shutdown point.

If the stroke rate reaches 46 an overstroke shutdown pending will be issued. If the condition exists for 30 seconds, an automatic shutdown will occur.

## 4.9 Hours Screen

The Hours Screen displays total machine operating hours and maintenance hours. Operating hours cannot be reset. Maintenance hours can be reset by pressing the RESET MAINT HOURS button.

*Figure 4-9: Hours Screen*

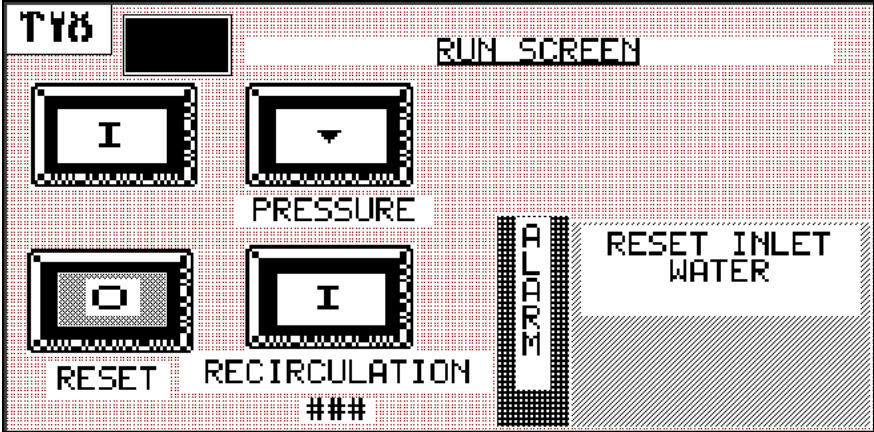




**4.10 Run Screen Alarms**

In an alarm state, the *last* alarm sensed by the machine will be displayed on the Run Screen. If multiple alarm conditions have occurred they can be viewed on the Alarms Screen. Run Screen alarms are listed in Table 4-2.

Figure 4-10: Run Screen Alarm



**Table 4-2  
Run Screen Alarms**

Alarm	Indication	Comments
Bleed High Pressure Lines	Intensifier is shut down, high pressure is present in the discharge plumbing and should be bled off to avoid possible injury.	Applies only when equipped with optional pressure transducer
Booster Temperature High	Booster pump water temperature is high, in excess of 128° F (53° C)	Shutdown will occur if condition persists.
High Oil Temperature	High hydraulic oil temperature, in excess of 144° F (62° C)	Shutdown will occur if condition persists.
High Pressure Warning	Output pressure is above 64,000 psi (4,413 bar)	Applies only when equipped with optional pressure transducer

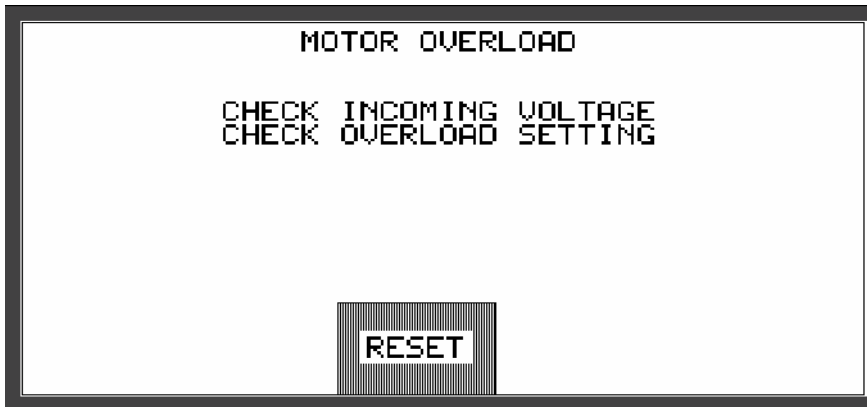
**Table 4-2**  
**Run Screen Alarms**

<b>Alarm</b>	<b>Indication</b>	<b>Comments</b>
Left/Right/Intensifier Overstroke	Abnormally high stroke rate caused by an external or internal leak. Shutdown will occur if condition persists.	<p>Overstroke warnings, pending shutdowns and shutdowns are issued as left, right or intensifier. An intensifier warning or shutdown indicates the intensifier is shifting too fast in both directions. If the machine is running near full capacity it is possible an intensifier shutdown is actually caused by a left or right fault. This can be diagnosed further by reducing the operating pressure and monitoring all alarm occurrences on the Alarms Screen.</p> <p>If the machine is equipped with a pressure transducer, another level of overstroke protection is obtained by shutting down at the warning level if the pressure is less than 3,000 psi (207 bar).</p>
Low Battery	Battery is low. After the alarm occurs, the battery will last for approximately seven days.	Replace with backup/replacement battery.
Low Booster Pressure	Booster pump output pressure is less than 30 psi (2 bar). Shutdown is pending.	Seven seconds after the machine is started, the booster pump output pressure switch is monitored. If the switch opens, a warning is issued. If the condition persists, shutdown will occur after 30 seconds.
Low Inlet Water Pressure	Cutting supply water pressure is inadequate to permit proper machine operation, less than 30 psi (2 bar).	If the inlet cutting watering pressure switch is not closed the machine will not start and a warning is issued. If the switch opens after the machine is started a warning is issued. If the condition persists shutdown occurs after five consecutive seconds.
Reset Inlet Water	Inlet water solenoid valve must be reset. RESET will flash and can be reset by pressing the STOP button.	

## 4.11 Alarm Banners

When a shutdown condition occurs an Alarm Banner will appear over the current screen. The banner displays the type of shutdown and lists possible remedies. Potential remedies are listed in order of most to least probable.

*Figure 4-11: Alarm Banner*



Pressing the RESET button will clear the alarm banner, but it will not clear the fault. The banner will continue to display until the fault is corrected. Shutdowns will appear on the Alarm History Screen. Alarm banner shutdowns are listed in Table 4-3.

**Table 4-3**  
**Alarm Banner Shutdowns**

<b>Alarm</b>	<b>Indication</b>	<b>Possible Remedies</b>
Booster Temp High	High booster water temperature	Check bleed orifice in low pressure water manifold
		Check for long idle times
		Check the inlet water switch
Left Overstroke Shutdown	A left overstroke condition has occurred	Check left HP seal
		Check right discharge
		Check left inlet check valve
Long Idle Time Shutdown	Intensifier has run in a deadhead condition for the operator adjusted time limit (5 to 60 minutes)	
Low Booster Pressure	Low water pressure from booster pump	Check booster adjustment
		Check booster condition



**Table 4-3**  
**Alarm Banner Shutdowns**

<b>Alarm</b>	<b>Indication</b>	<b>Possible Remedies</b>
Low Inlet Water Pressure	Low inlet water pressure	Check water supply
		Check water filter
Motor Feedback Failure	Start relay did not close at start-up or opened due to a fault	Check the motor starter relay
Motor Overload	PLC monitors the motor overload relay and displays a message when the overloads trip. Overloads are set on automatic reset.	Check incoming voltage
		Check overload setting
		Check the motor amperage
Oil Level Low	Low oil level	Check level gauge
		Check for hydraulic leaks
		Check the oil level switch
		Check inlet and discharge check valves
Right Overstroke Shutdown	A right overstroke condition has occurred	Check right high pressure seal
		Check left discharge
		Check right inlet check valve
T/W Overstroke Shutdown	An intensifier overstroke condition has occurred	Check plumbing for leaks
		Check high pressure orifice
		Check incoming water pressure
		Check inlet and discharge check valves

#### **4.12 Alarms Screen**

Multiple alarms can be viewed on the Alarms Screen. During normal operation, warning and pending alerts are not visible. If an alarm condition occurs the appropriate warning or pending message will display and flash. Table 4-4 describes these alarm conditions.

Figure 4-12: Alarms Screen

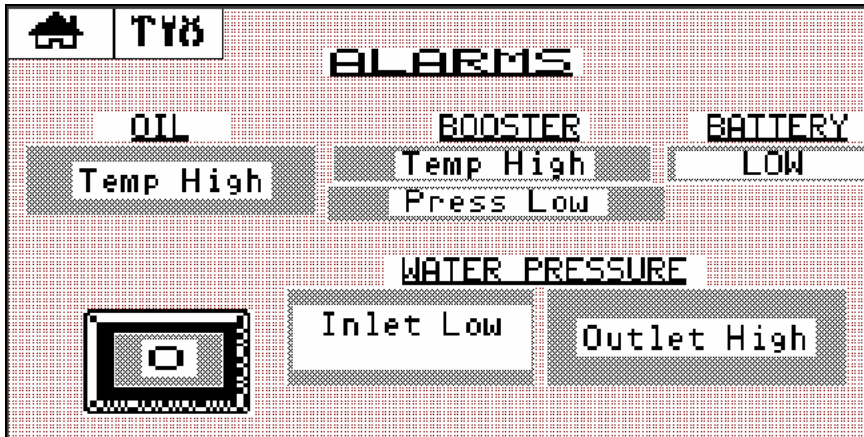


Table 4-4  
Alarms Screen

Alarm		Indication	Result
Overstroke		High stroke rate caused by external or internal leak	First a WARNING, and then a PENDING shutdown alarm will occur. If the condition persists a shutdown will occur.
Oil		High oil temperature, in excess of 150° F (65° C)	Shutdown will occur 60 seconds after detection.
Booster	Temp High	High booster water temperature, in excess of 128° F (53° C)	Shutdown will occur 30 seconds after detection.
	Press Low	Low water pressure from booster pump, less than 30 psi (2 bar)	Shutdown will occur 20 seconds after detection.
Battery Low		Battery is low and needs to be replaced	The battery will last approximately seven days after the alarm occurs.
Water Pressure	Inlet Low	Low inlet water pressure, less than 30 psi (2 bar)	Shutdown will occur if condition persists for 5 continuous seconds.
	Outlet High	Excessively high outlet water pressure, in excess of 64,000 psi (4,413 bar)	Available only when equipped with optional pressure transducer. Does not result in a shutdown.

**Installing a New Battery**

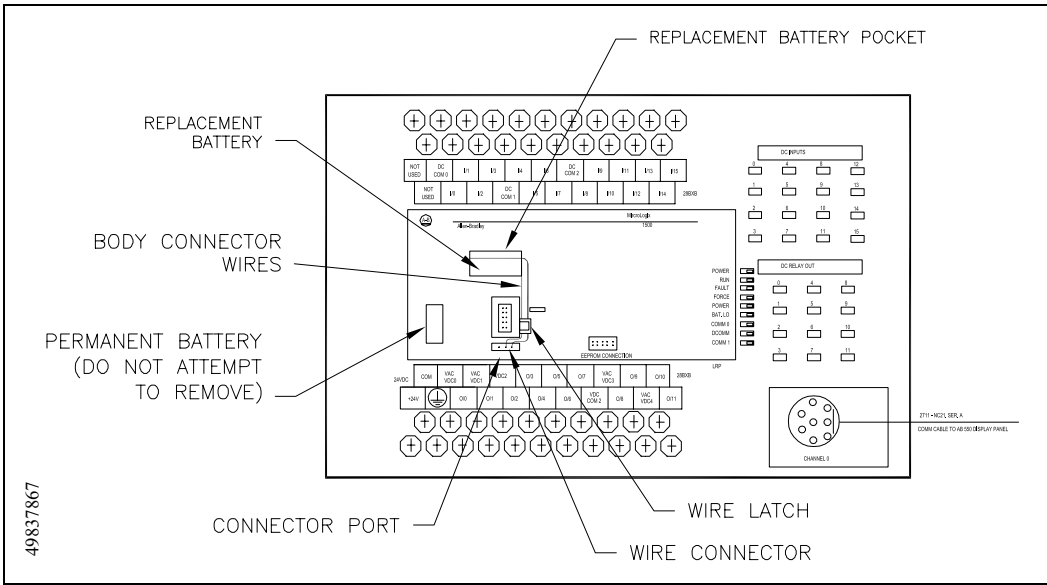
The following procedure is used to change the replacement battery.



**Do not attempt to remove the permanent battery.**

1. Insert the new battery into the replacement battery pocket with the wires facing up.
2. Insert the wire connector for the replacement battery into the connector port.
3. Secure the battery wires under the wire latch as shown in Figure 4-12, Battery Replacement.

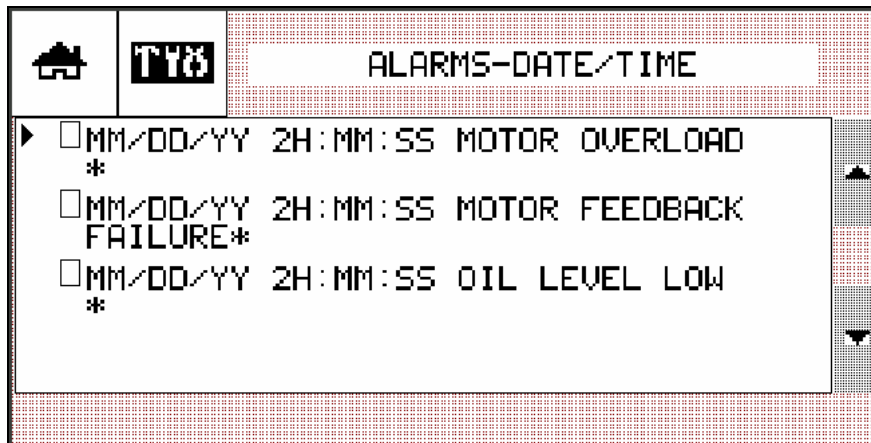
**Figure 4-13: Battery Replacement**



### 4.13 Alarm History

The Alarm History Screen displays the last 100 shutdown alarms indicating date, time and type of alarm. Use the ▲ or ▼ arrow to view past alarms.

Figure 4-14: Alarm History Screen



### Changing the Date and Time

The following procedure is used to change the date and time.

1. Remove power from the display by pressing the E-STOP button.
2. Pull the E-STOP button out and press the RESET button to energize the display panel.
3. Shortly, the number 24 will display. Ten seconds later, the number 32 will replace the number 24 and a small blinking square will display on the bottom, right of the screen.
4. Press the blinking square to initialize the Configuration Screen used to set the parameters for the panel display.
5. Select Date/Time and press ENTER. Set the year, month, day, hour, minutes and seconds. Press EXIT to return to the previous screen.
6. Select Run Mode and press ENTER to return to the display panel.

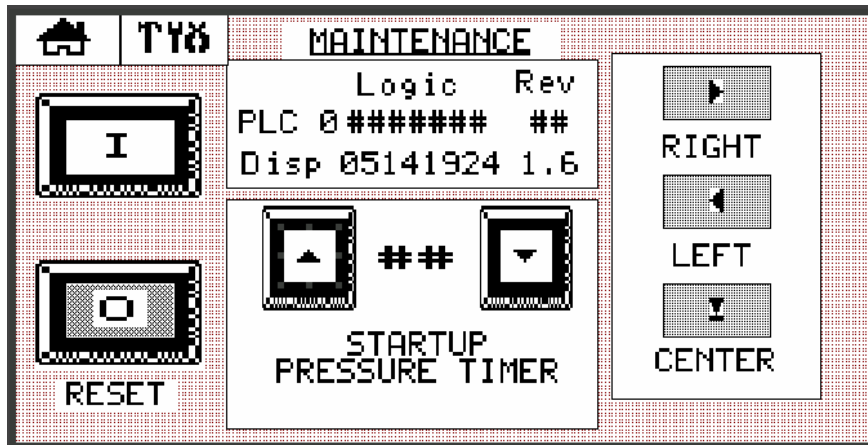
### 4.14 Configuration Screen

The Configuration Screen is a password protected screen, used only at initial startup to set the horsepower. If a new version of the display program is installed you must press the RESET HP button on the Setup Screen to update the displays.

## 4.15 Maintenance Screen

The Maintenance Screen is used to facilitate maintenance procedures and provides the PLC and display logic part number and revision number. When started from the Maintenance Screen, the machine starts in recirculation mode.

Figure 4-15: Maintenance Screen



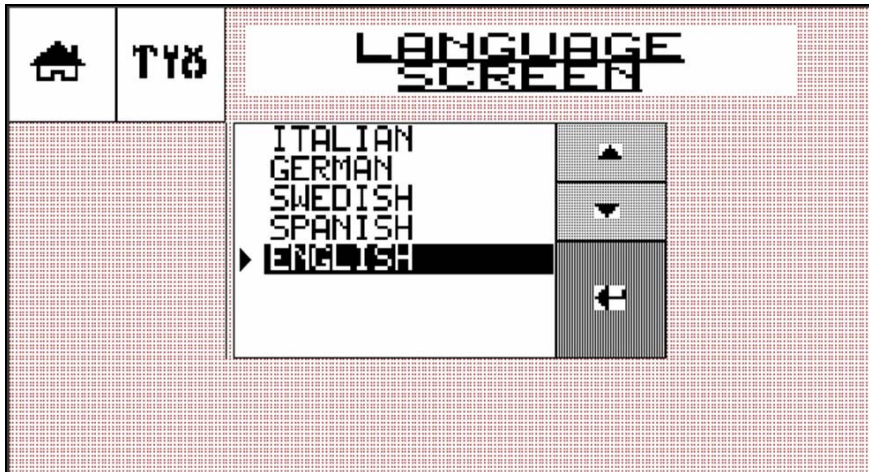
The machine must be started from the Maintenance Screen to access the following functions:

- START button will start the machine in recirculation mode and open the dump valve
- STOP button will stop the machine
- RESET is the inlet water solenoid indicator. The inlet water solenoid valve is automatically closed five minutes after the machine shuts down. When it flashes, press the STOP button to reset and open the valve.
- STARTUP PRESSURE TIMER; press the ▲ or ▼ arrow to select a startup time from 5-60 seconds. This will determine the startup time between low and high pressure operation.
- RIGHT arrow will open the dump valve and extend the piston to the right, allowing full exposure to the right plunger when the unit is disassembled. ***The unit must be completely assembled to use this jog function.***
- LEFT arrow will open the dump valve and extend the piston to the left, allowing full exposure to the left plunger when the unit is disassembled. ***The unit must be completely assembled to use this jog function.***
- CENTER symbol will open the dump valve and position the piston in the center of the hydraulic cylinder. To center the piston, first press the RIGHT arrow to extend the plunger to the right, then press the CENTER symbol to center the piston. ***The unit must be completely assembled to use this jog function.***

### 4.16 Language Screen

The Language Screen lists the available display languages. Press the ▲ or ▼ arrow to highlight the desired language. Press ENTER (↵) to select.

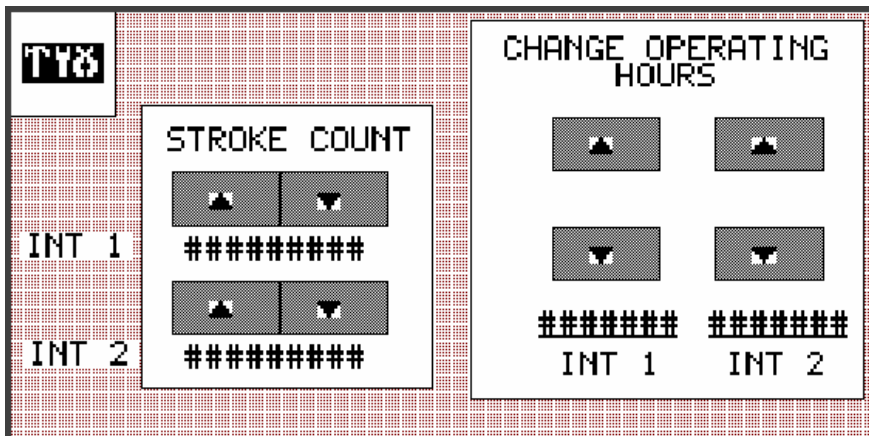
Figure 4-16: Language Screen



### 4.17 Configuration II Screen

The Configuration II Screen is a password protected screen, used to change the stroke count or the operating hours. The password to access the Configuration II Screen is 111320.

Figure 4-17: Configuration II Screen



- STROKE COUNT; press the ▲ or ▼ arrow to increase or decrease the stroke reading in increments of 100 strokes. The stroke count can not be changed if the pump is running.
- CHANGE OPERATING HOURS; press the ▲ or ▼ arrow to increase or decrease the operating hours in increments of one hour.



## SECTION 5

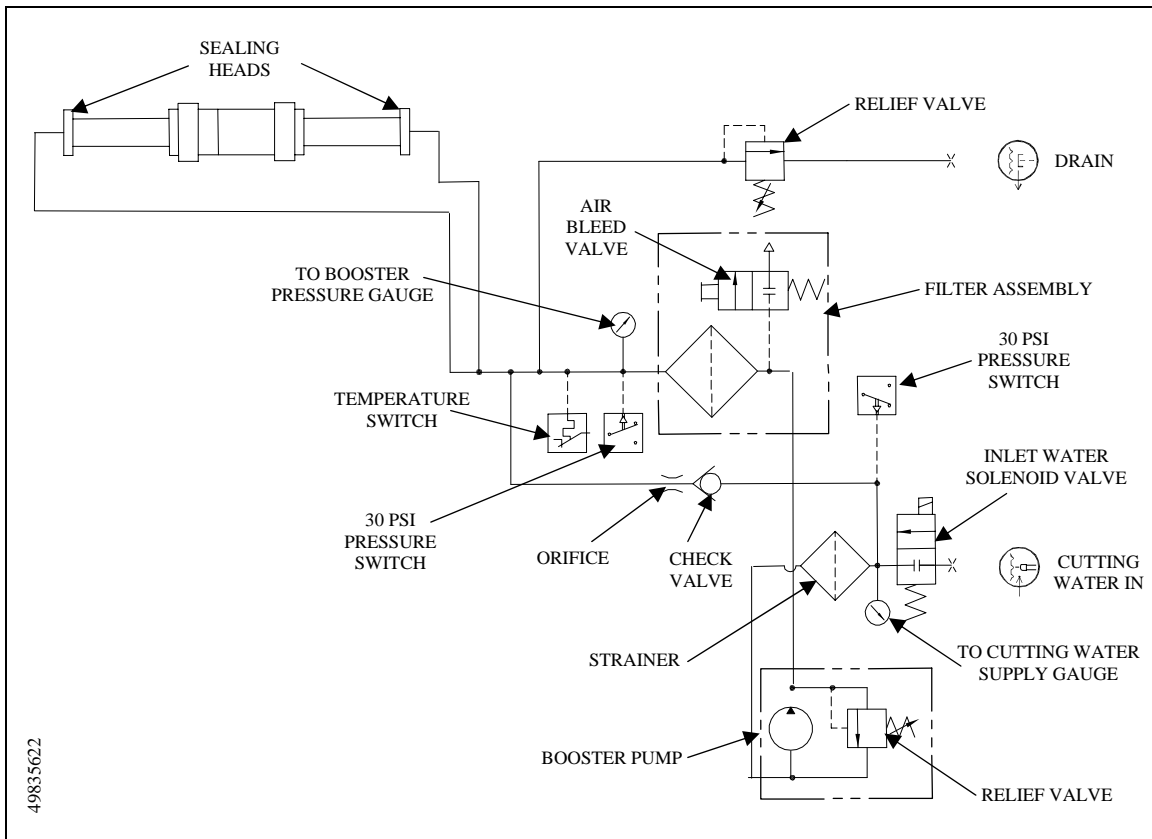
### LOW PRESSURE WATER SYSTEM

#### 5.1 Overview

The SL-V SRP 100 intensifier utilizes two low pressure circuits: cutting water supply and cooling water supply. This section will discuss the cutting water supply circuit. See Section 6, Recirculation System, for a detailed explanation of the cooling water supply circuit.

The cutting water supply circuit supplies the intensifier with the required cutting water flow and pressure. System components include the inlet water solenoid valve, strainer, booster pump, and the low pressure filter assembly. Pressure and temperature switches, connected to the PLC, monitor out of tolerance conditions in the cutting water circuit and provide automatic shutdown protection.

*Figure 5-1: Cutting Water Supply Circuit*





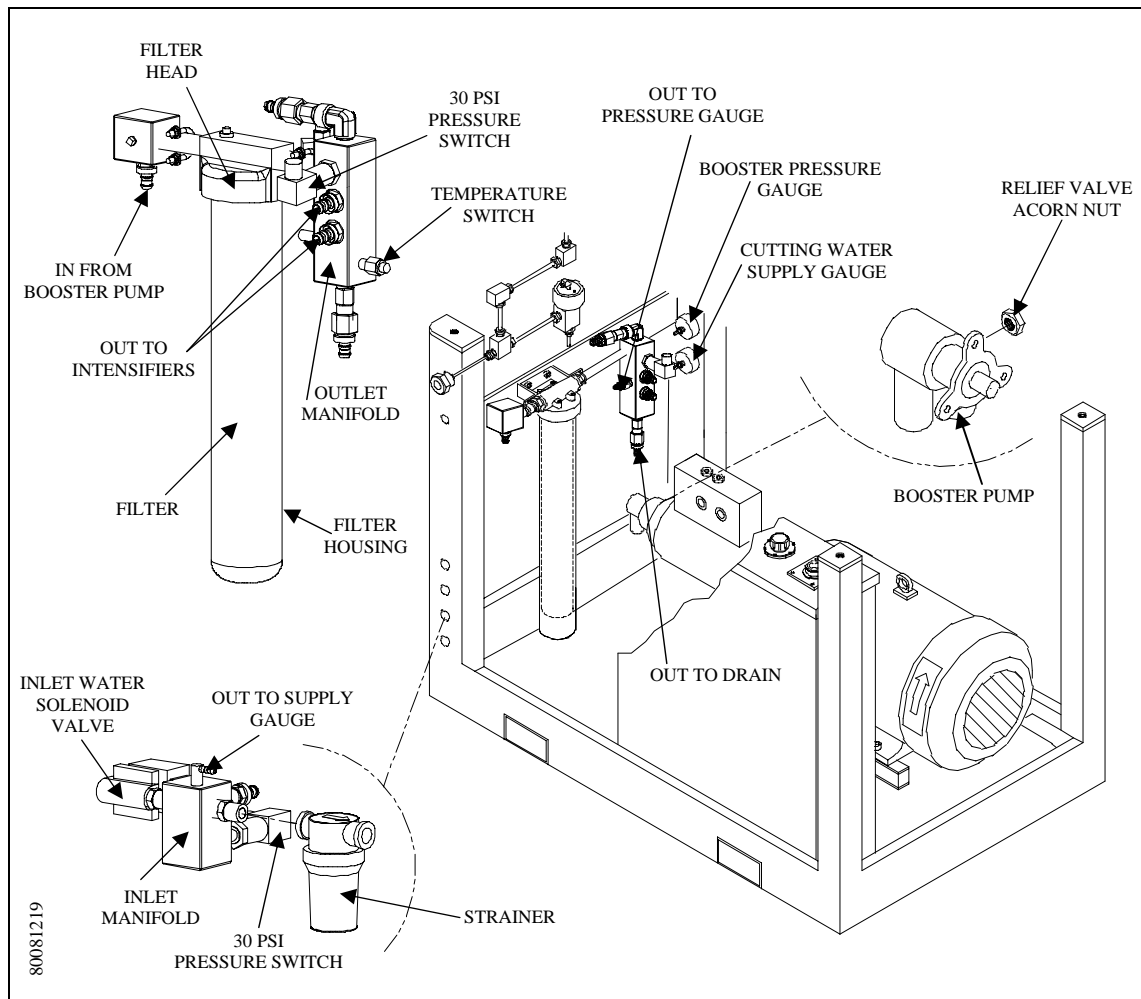
## 5.2 Cutting Water Supply

The quality of the inlet cutting water supply is one of the most important factors affecting component life and performance. Impurities in the water create grinding and corrosive effects on all components. See Section 11, Specifications, for details regarding water quality standards.

## 5.3 Operation

Cutting water is introduced through the 1/2-inch NPT connection on the rear bulkhead of the machine. Inlet cutting water pressure should be a minimum of 35 psi (2.4 bar) flowing, and can be monitored from the Cutting Water Supply Gauge on the front of the machine.

Figure 5-2: Low Pressure Water System



Cutting water enters through the normally closed, inlet water solenoid valve. When the control power is turned on, the solenoid valve opens and allows water to flow through the valve. The inlet water is monitored by a 30 psi pressure switch mounted on the inlet manifold. If the pressure drops below 30 psi (2 bar) the switch activates an automatic shutdown circuit in the PLC





and the machine will not start. Additionally, the valve automatically closes at the idle shutdown interval selected by the operator.

**NOTE**

The machine will not start if inlet cutting water pressure is below 30 psi (2 bar).

Cutting water then passes through a strainer to remove debris before the water enters the booster pump. The booster pump increases the pressure to the relief valve setting, up to a maximum of 120 psi (8 bar) to ensure proper supply to the intensifier assembly.

Pressurized water passes through the filter assembly where debris is removed to prevent contaminants from damaging the check valves and seals in the intensifier. The filter assembly consists of a filter head, housing and a 10 micron absolute filter. A bleed valve on the top of the filter head is used to release pressure or air inside the housing.

As the water enters the outlet manifold, the discharge pressure is monitored by a 30 psi pressure switch. An automatic shutdown will occur if the booster pressure stays below 30 psi (2 bar) for the amount of time programmed into the controller.

If the booster pump pressure exceeds 125 psi (8.6 bar) a relief valve opens allowing water to exit through the 1/2-inch drain connection on the rear bulkhead. It is still possible to operate the machine; however, excess water will continue to be released through the drain.

Discharge pressure is displayed on the Booster Pressure Gauge on the front of the machine. The gauge should read approximately 120 psi (8 bar) while the machine is idling.

**NOTE**

While the intensifier assembly reverses direction, the boosted pressure will fluctuate above and below the normal setting.

A relief valve built into the filter assembly prevents excessive discharge pressure and typically operates when the machine is in a deadhead condition. The booster pump is factory set to deliver 120 psi (8 bar) with an inlet pressure of 58 psi (4 bar). The pump may require adjustment to satisfy system requirements.

A temperature switch, mounted on the outlet manifold, monitors the discharge temperature. If the temperature exceeds 128° F (53° C), the switch activates an automatic shutdown circuit in the PLC that stops the main motor. The temperature switch prevents booster pump overheating due to lack of water or long deadhead conditions. To reduce overheating during a deadhead condition, water is re-circulated through the orifice and check valve, and routed back through the strainer to the booster pump inlet.

From the outlet manifold, cutting water is routed to the inlet check valves in the sealing heads on each end of the intensifier.

## 5.4 Service and Maintenance Procedures

To ensure water quality and supply to the high pressure system, the filter element, strainer and booster pump will require routine servicing and maintenance. The procedures for servicing these components are detailed below.

### NOTE

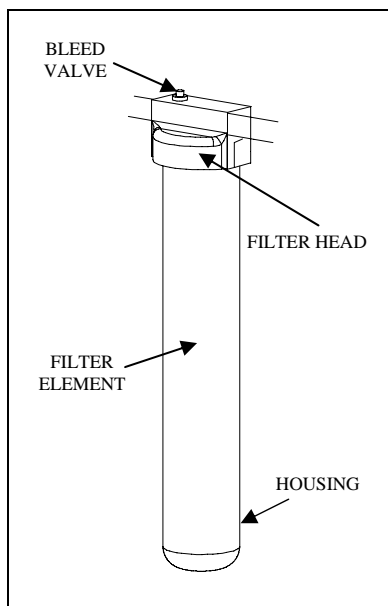
Refer to Section 12, Parts List for a complete listing of replacement parts and part numbers.

### Filter Assembly and Strainer Maintenance

The life of the filter element is directly related to the quality of the inlet water. The condition of the filter element can be monitored by observing the Booster Pressure Gauge on the front of the machine. Document the pressure reading when the filter element is new. The element should be replaced when the pressure drops to 15 psi (1 bar) below the original value. When the filter element is replaced, the strainer should also be cleaned.

The following procedure is used to replace the filter element and clean the strainer.

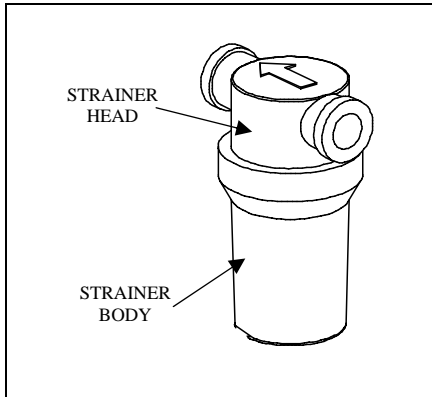
**Figure 5-3: Filter Element**



1. Turn the cutting water supply off.
2. Press the red bleed valve on the filter head to release any pressure trapped inside the housing.
3. Use a filter wrench to unscrew the housing and remove the old element.

4. Install the new element. Apply FML-2 grease to the o-ring in the filter housing and use the filter wrench to replace the housing.

**Figure 5-4: Strainer**

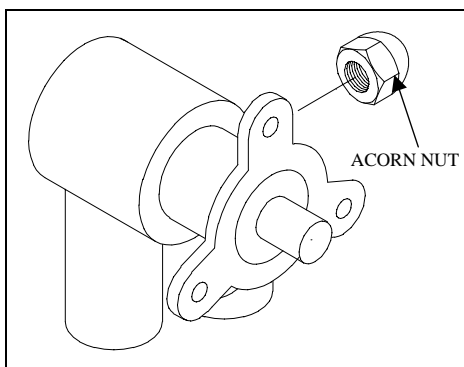


5. Unscrew and remove the strainer body. Remove and clean the mesh liner.
6. Ensure the gasket is properly positioned in the body, install the liner and screw the strainer body into the strainer head, hand tighten.
7. Turn the cutting water supply on.
8. Press the red bleed valve to remove any air inside the housing.
9. Start the machine and verify satisfactory pressure readings.

### **Booster Pump Adjustment**

If the discharge pressure from the booster pump stays below 90 psi (6 bar) while the intensifier is shifting, the relief valve on the booster pump should be adjusted.

**Figure 5-5: Booster Pump**



1. Turn the cutting water supply on.
2. Start the machine and initiate normal, shifting operation.

3. Observe the discharge pressure from the booster pump. If the pressure stays below 90 psi (6 bar), continue with Step 4.
4. Stop the intensifier and remove the acorn nut on the side of the pump to access the adjustment screw. It is normal for water to leak out when the acorn nut is removed.
5. Use a flat screwdriver and turn the adjustment screw clockwise to increase the discharge pressure or counter-clockwise to decrease the pressure. Adjust the pressure to the highest desired pressure, within normal booster pump range.



If the adjustment screw is turned too far out (counter-clockwise) an internal spring and relief will fall down inside the pump. If this occurs, the pump must be removed and the parts must be reinstalled to avoid component damage.

6. Replace the acorn nut, resume normal operation and observe the booster pressure. Peak pressure should be in the range of 90 to 120 psi (6 to 8 bar). If not, repeat the adjustment procedure.



## SECTION 6

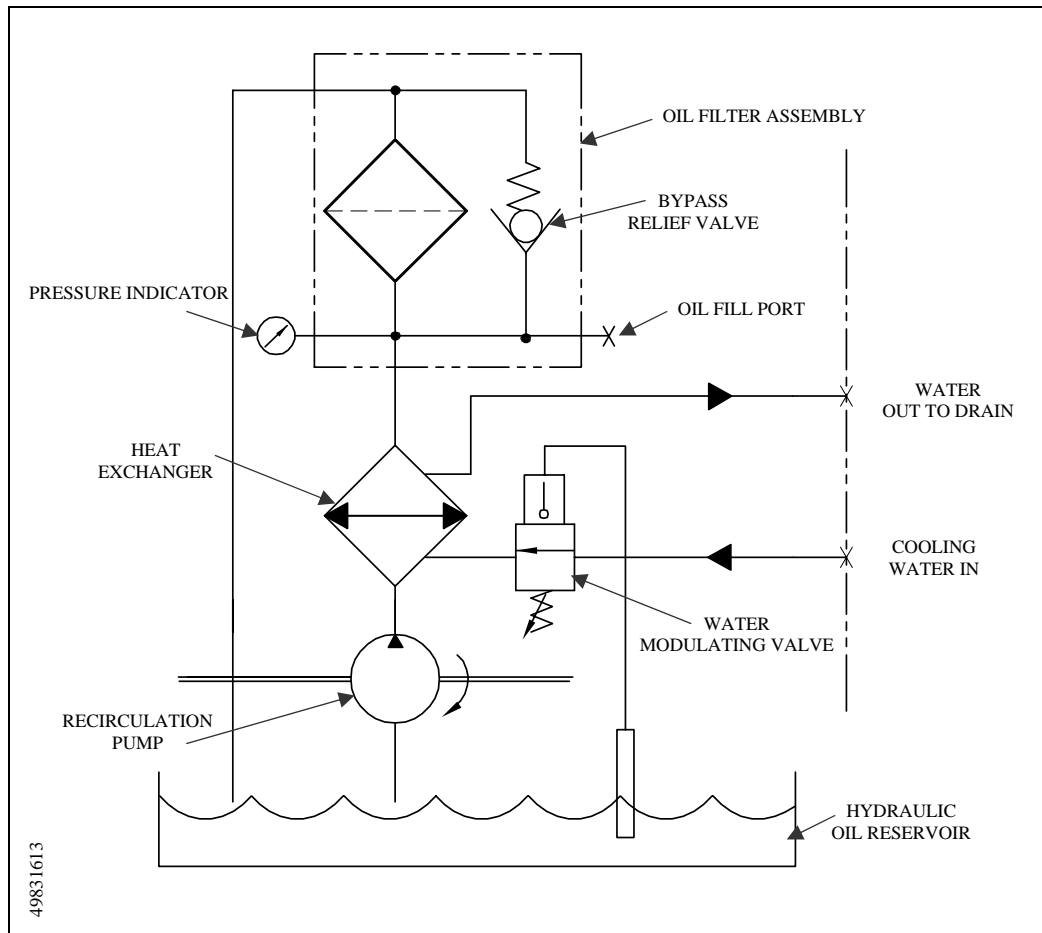
### RECIRCULATION SYSTEM

#### 6.1 Overview

The oil recirculation circuit is a cooling and filtration system that provides properly conditioned oil to the main hydraulic system. Hydraulic oil is maintained at the proper operating temperature and condition by continuous recirculation.

System components include the water modulating valve, recirculation pump, heat exchanger, oil filter assembly and the hydraulic oil reservoir. A temperature/low level switch, connected to the PLC, monitors temperature and oil level conditions in the hydraulic oil reservoir and provides automatic shutdown protection.

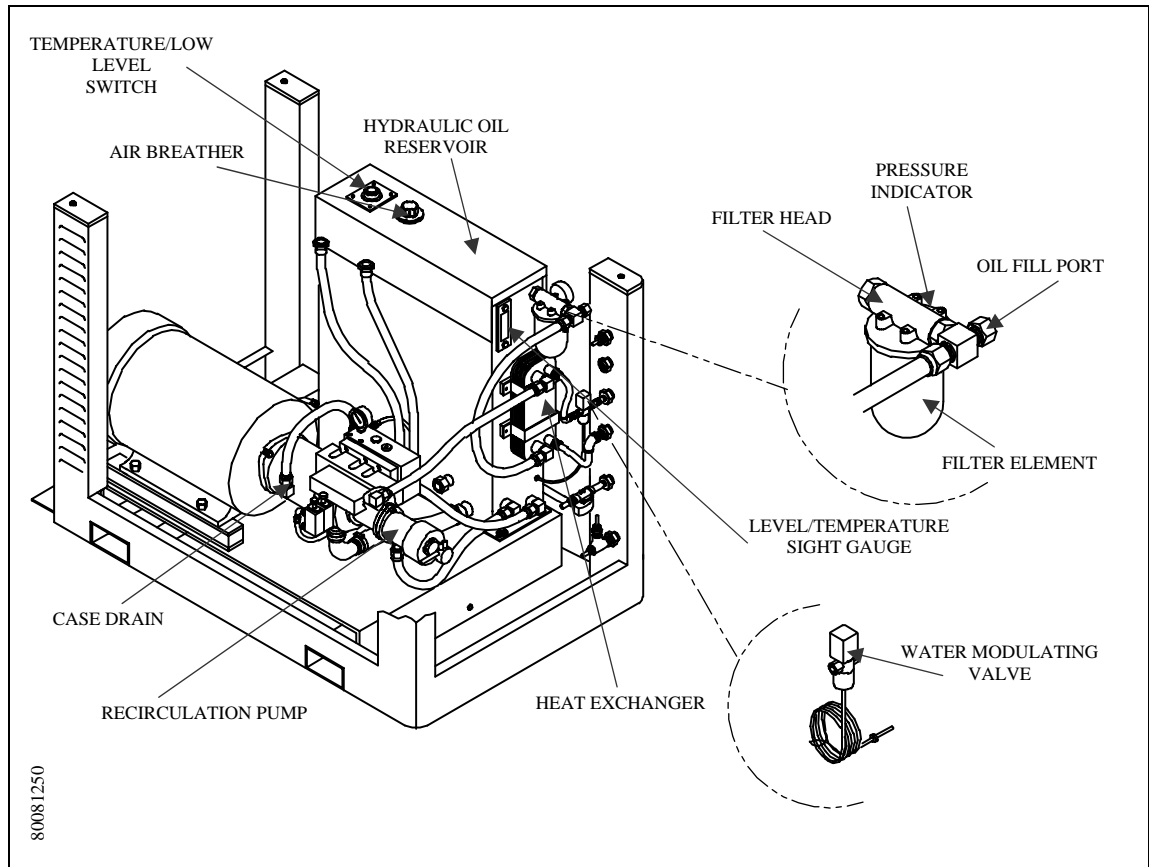
*Figure 6-1: Oil Recirculation Circuit*



## 6.2 Operation

Cooling water is introduced through the 1/2-inch NPT connection on the rear bulkhead of the machine where the water modulating valve regulates the cooling flow to the heat exchanger. The valve is factory set, but may require adjustment to maintain the operating oil temperature at 110-115° F (43-46° C). Oil temperature can be visually monitored from a dual scale level/temperature sight gauge on the side of the hydraulic oil reservoir.

**Figure 6-2: Recirculation System Components**



The recirculation pump pulls oil from the reservoir and sends it to the heat exchanger. The oil-to-water heat exchanger controls heat build-up in the hydraulic oil. The plate style design allows cooling water and oil to flow side by side through alternating plates.

The cooled oil then passes through the filter element and returns to the reservoir. The cooling water either is discharged to the 1/2-inch NPT drain on the rear bulkhead or is routed to a customer supplied water chiller.

The hydraulic oil filter assembly consists of the filter head, a filter element, a differential pressure indicator, bypass relief valve and the oil fill port. The filter element should be changed when the indicator enters the red zone at normal operating temperature.

If the element is not replaced, and fills with debris, the bypass relief in the filter head will open to prevent over pressurization. The relief valve opens at 25 psi (1.7 bar). When the valve opens, the oil bypasses the filter and unfiltered oil is allowed to return to the reservoir.

The temperature/low level switch monitors the oil temperature and level in the reservoir. An automatic shutdown will occur if the operating oil temperature exceeds 144° F (62° C). An automatic shutdown will also occur if the oil level below 37 gal (140 L).

**NOTE**

To conserve water usage it is recommended that the cooling water be shut off at the end of the day. A sensor bulb from the modulating valve is submerged in the reservoir. Even when the control power is off, the valve will remain open, allowing water to flow until the oil is cooled.

### 6.3 Service and Maintenance Procedures

To ensure the supply of properly conditioned oil to the main hydraulic system, the components will require routine servicing and maintenance. The procedures for servicing these components are detailed below.

**NOTE**

Refer to Section 12, Parts List for a complete listing of replacement parts and part numbers.

#### Hydraulic Oil Maintenance

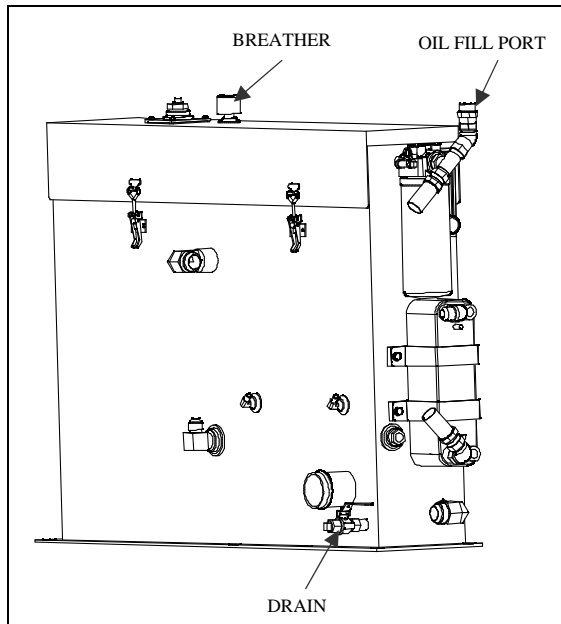
The hydraulic oil should be replaced after 3,000 hours or one year of service, whichever comes first. The oil should be replaced sooner if a fluid sample indicates contamination that cannot be rectified by filtering.

An air breather and filter is located on the top of the reservoir. The air breather prevents dirt from being sucked into the reservoir when the oil level drops, and allows air to escape when the level rises. The air breather must not be used as a fill point. Oil **must only** be replaced at the fill port on the filter head.



**Do not** attempt to fill the reservoir from the air breather. The oil will not be filtered and will not conform to the cleanliness requirements of the system.

**Figure 6-3: Hydraulic Reservoir**



Before proceeding, disconnect and lockout the main power supply and the electrical enclosure; and ensure that all high pressure water and hydraulic pressure has been bled from the system.



Severe injury can result if the machine is not properly locked out. Observe electrical Lockout/Tagout procedures before performing maintenance.

Ensure all pressure is relieved or blocked from the hydraulic and high pressure circuits before performing maintenance.

1. Drain the oil reservoir by connecting the inlet hose from an oil transfer pump to the drain valve on the reservoir.
2. Open the shut off valve on the drain and pump the used oil out to a container.
3. Close the shut off valve and remove the inlet hose from the drain valve.



**NOTE**

Oil from a new drum does not meet the cleanliness requirements of the hydraulic system. For this reason, it is important to use an oil transfer pump that will force oil through the return filter into the reservoir.

4. Remove the cap from the fill port on the oil filter.



To ensure cleanliness, the oil fill port **must** be used to pump oil into the reservoir. Filling at this point guarantees the hydraulic oil will pass through the oil filter before entering the reservoir.

5. Connect the discharge hose from the oil transfer pump to the fill port and pump the fresh oil into the reservoir.

**NOTE**

If 3/4-inch BSPP threads are required, install the adapter located on the inside of the frame. When filling is complete, remove the adapter and install the fill port cap.

6. Check the oil sight gauge on the reservoir to ensure proper fill level.
7. Remove the hose from the case drain on the main hydraulic pump to make sure the pump case fills with oil. With the hose removed, head pressure from the reservoir will force oil into the pump case.



Oil in the pump case provides internal lubrication for the main hydraulic pump. Failure to fill the pump case with oil will allow air to become trapped inside, damaging the pump.

8. Disconnect the discharge hose from the fill port and replace the fill port cap.
9. Follow the initial start up sequence in Section 4, Operation, to ensure the system is filled with oil.
10. Check the sight gauge again and follow the same procedure to add additional oil if necessary.

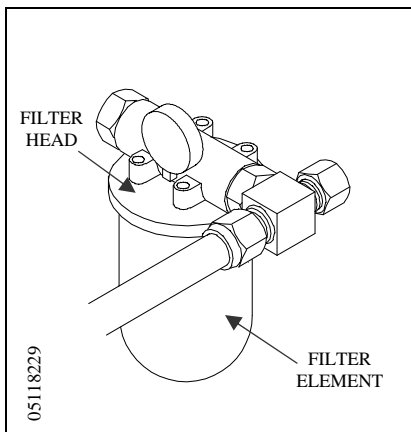
## Oil Filter Maintenance

If the filter element is not properly serviced and fills with debris, the oil will be forced through the relief valve, bypassing the filter. The bypass relief valve opens at 25 psi (1.7 bar). The filter element must be replaced when the pressure indicator meets the criteria listed in Table 6-2.

**Table 6-2**  
**Hydraulic Oil Filter Change Criteria**

Horsepower	Indicator	Criteria
100	Differential pressure indicator	Replace filter element when the indicator is in the yellow zone or entering the red zone during normal operating conditions.
<i>Note</i>		Normal operating conditions indicate the machine is running and the oil temperature has reached 115° F (46° C).

**Figure 6-4: Oil Filter Assembly**



1. Use a filter wrench to unscrew the filter element from the filter head. Make sure the old gasket is removed with the element.
2. Lubricate the gasket on the new element with fresh oil.
3. Use the filter wrench to screw the new element onto the filter head and hand-tighten. Do not over tighten.
4. Start the machine and check for leaks.

### NOTE

If the pressure indicator is in the red zone after the filter is changed, check the operating condition of the indicator. The indicator may require replacement.

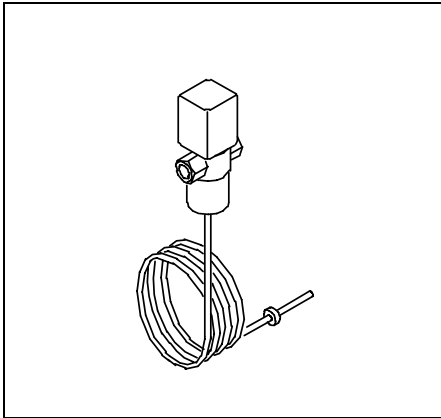
### Operating Temperature Adjustment

The cooling water flow to the heat exchanger is regulated by the water modulating valve, a manually adjusted, thermostatic control valve. The valve is factory set to maintain the operating oil temperature at 110-115° F (43-46° C). It is adjusted by increasing or decreasing the spring tension on the valve.

#### NOTE

In most cases, adjustment will be required during commissioning and with seasonal changes to the cooling water temperature.

**Figure 6-5: Water Modulating Valve**



1. Locate the adjusting knob, a screwdriver slot on the top of the valve.
2. Use a flat screwdriver and turn counter-clockwise to compress the spring, slowing water flow and increasing temperature. Or; turn clockwise to reduce spring tension, increasing water flow and decreasing the temperature.
3. Monitor the sight gauge on the side of the reservoir until the adjusted temperature can be determined. It will take some time for the temperature in the oil reservoir to change.
4. Repeat steps 2 and 3 if necessary.



## SECTION 7

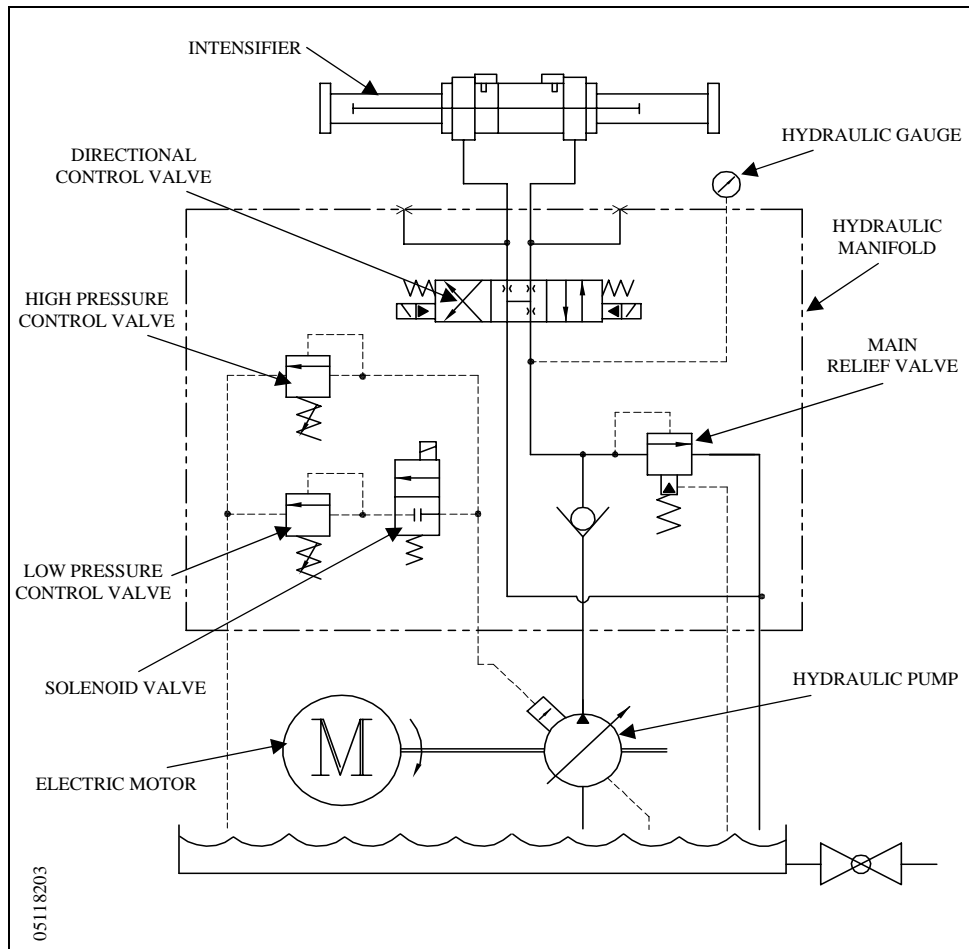
### HYDRAULIC SYSTEM

#### 7.1 Overview

The main hydraulic power circuit supplies the intensifier assembly with the hydraulic oil required to produce high pressure water. High pressure cutting water is generated from the oil pressure in the hydraulic cylinder.

System components include the electric motor, hydraulic pump, 4-way directional control valve and the hydraulic manifold. The manifold houses the high and low pressure control valves, hydraulic gauge, two pressure solenoid valve and the main system relief valve. The system relief valve monitors hydraulic oil pressure and provides system protection by limiting excess pressure.

*Figure 7-1: Main Hydraulic Power Circuit*



## 7.2 Optional System Components

Optional proportional pressure control enhances the standard high and low pressure selection by allowing the operator to select or vary the hydraulic operating pressure from the control panel or from a remote console. From the Pressure Control Screen the high pressure can be set as a percentage, from 0% to 100%. An electronically controlled hydraulic cartridge valve receives a signal from the PLC and automatically makes the operator selected adjustments.

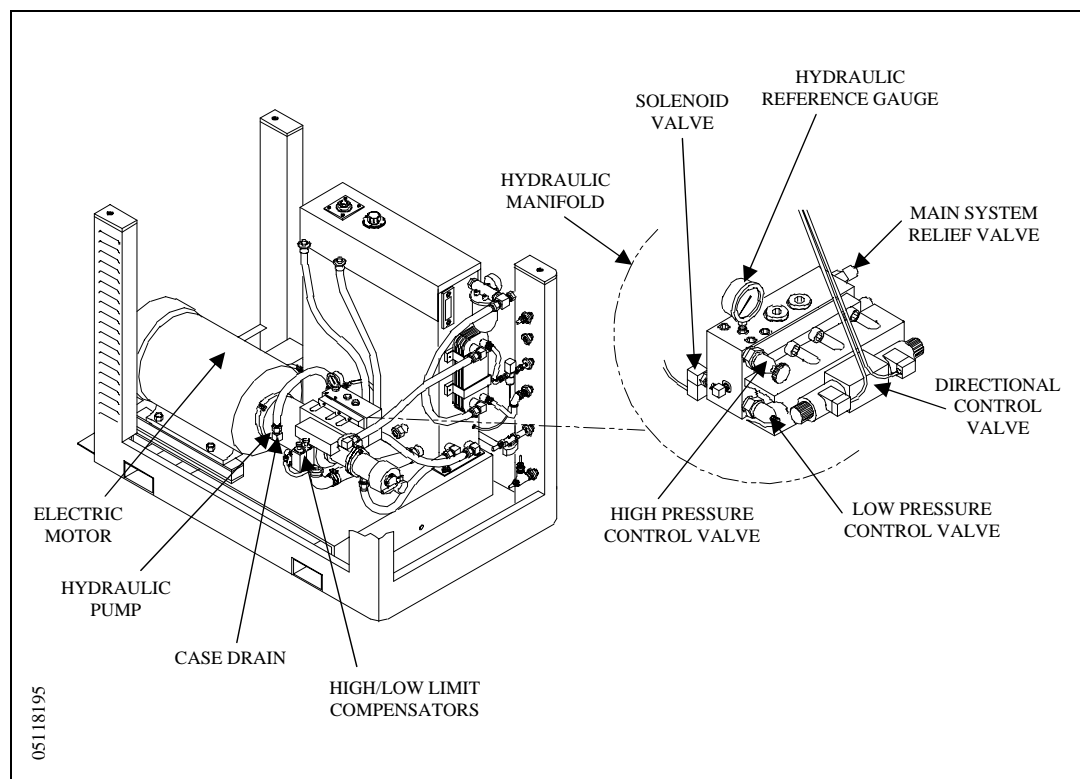
As proportional pressure controls hydraulic oil pressure, it also determines cutting water pressure based on the intensification ratio.

## 7.3 Operation

The electric motor drives three pumps mounted in tandem; the main hydraulic pump, the recirculation pump and the booster pump. The motor drives the variable displacement, pressure compensated hydraulic pump by means of a flexible coupling.

Hydraulic fluid from the reservoir is drawn into the inlet, low pressure side of the hydraulic pump. Oil delivered to the pump should be maintained at 110-115° F (43-46° C). Hydraulic fluid then enters the bottom of the manifold through an internal anti-rotation check valve. After a shutdown, the anti-rotation check valve prevents the pump from running backwards.

*Figure 7-2: Hydraulic System Components*



The main system relief valve provides system protection by monitoring the oil pressure entering the manifold. If the hydraulic pressure exceeds 3,400 psi (235 bar), the valve opens to limit the pressure. The valve is factory calibrated and is not serviceable. A drain line from the valve prevents oil from collecting behind the relief valve to ensure a constant pressure under all operating conditions.

The hydraulic system operates at high or low pressure settings up to the maximum flow capacity of the hydraulic pump. The high and low limit compensators mounted on the pump regulate the flow of hydraulic fluid to maintain constant operating pressures. Operating pressures are set and adjusted at the high and low pressure control valves on the manifold.

If the machine is equipped with proportional pressure control, low pressure is adjusted at the manifold, and the high pressure setting is made from the control panel or a remote console.



The high and low limit compensators regulate the flow of hydraulic fluid to the system by controlling the angle of the swashplate. If the oil is not properly maintained, the compensators can become blocked with debris. As a result, pump control will be lost and you will not be able to create hydraulic oil pressure.

The normally closed, two pressure solenoid valve is controlled by the operator's selection of high or low pressure. The valve is closed while operating in high pressure and is open during low pressure operation. A light on the solenoid connector indicates low pressure operation.

At startup, hydraulic pressure is automatically switched to low, limiting torque demand. After 5-60 seconds, depending on the interval selected by the operator, hydraulic pressure automatically returns to the previously selected pressure setting.

A reference gauge on the top of the manifold displays hydraulic pressure to the intensifiers. When the intensifier shifts, it is normal for the pressure to quickly fall and then rise again.

The 4-way directional control valve directs pressurized oil to one end the hydraulic cylinder and returns fluid to the reservoir from the opposite end, causing the intensifier to stroke. The movement is controlled hydraulically by a pilot valve that is electronically operated by two solenoids, energized by the PLC. Indicators light up as each solenoid is energized.

The directional control valve sends flow to the hydraulic cylinder in one direction until the hydraulic piston activates the proximity switch at the end of the stroke. The activated switch sends a signal to the PLC to reverse the direction of flow. The piston then moves in the opposite direction until it activates the proximity switch at the opposite end of the stroke.

## 7.4 Service and Maintenance Procedures

The extreme duty cycles demanded of the hydraulic system make routine inspection and maintenance acutely important. Leaks must be detected and remedied as soon as possible.

The operating pressure settings must be checked daily, and the electric motor must be inspected at regular intervals. It is also possible for the flexible coupling to fail and require replacement. The procedures for servicing these components are detailed below.

**NOTE**

Refer to Section 12, Parts List for a complete listing of replacement parts and part numbers.

### Hydraulic Operating Pressure

Hydraulic operating pressure settings should be checked daily and adjusted as necessary. High and low operating pressure on standard machines is adjusted at the high and low pressure control valves per the specifications in Table 7-2.

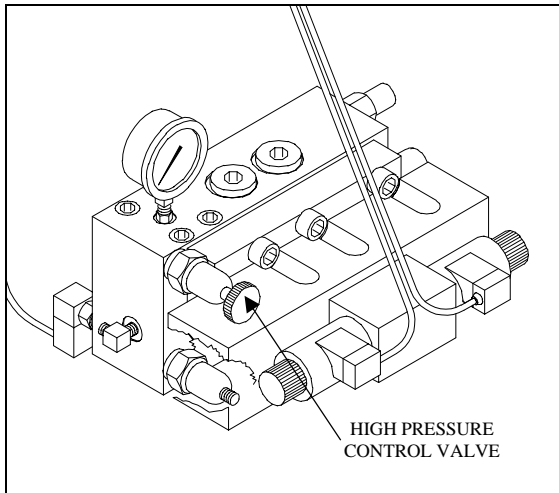
For machines equipped with proportional pressure control, high pressure adjustments are made from the Pressure Control Screen on the control panel. The following specifications and the Low Pressure Adjustment procedure are used for low pressure adjustments.

**NOTE**

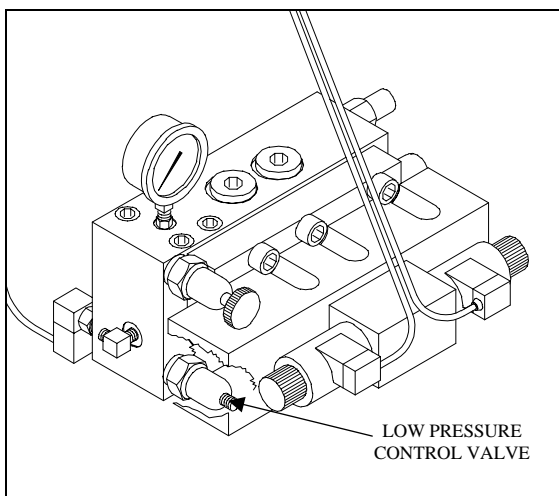
The PRESSURE switch on the control panel must be set to high pressure to enable the PROPORTIONAL PRESSURE control.

**Table 7-2**  
**Hydraulic Operating Pressure Limits**

	Adjustment		Pressure Limits	
	Increase	Decrease	Minimum	Maximum
High Pressure	Clockwise	Counter-clockwise	290 psi (20 bar)	2,815 psi (194 bar)
Low Pressure	Clockwise	Counter-clockwise	290 psi (20 bar)	1,450 psi (100 bar)

**Figure 7-3: High Pressure Control Valve**

1. Check the operating pressure to determine if adjustment is necessary.
2. If high pressure adjustment is required, loosen the locking nut on the high pressure control valve by turning counter-clockwise.
3. Turn the knob on the control valve clockwise to increase operating pressure. Turn the knob counter-clockwise to decrease pressure.
4. Tighten the locking nut and verify the high pressure setting.

**Figure 7-4: Low Pressure Control Valve**

1. Check the operating pressure to determine if adjustment is necessary.
2. If low pressure adjustment is required, loosen the locking nut on the low pressure control valve by turning counter-clockwise.



3. Turn the hex clockwise to increase operating pressure. Turn the hex counter-clockwise to decrease pressure.
4. Tighten the locking nut and verify the low pressure setting.

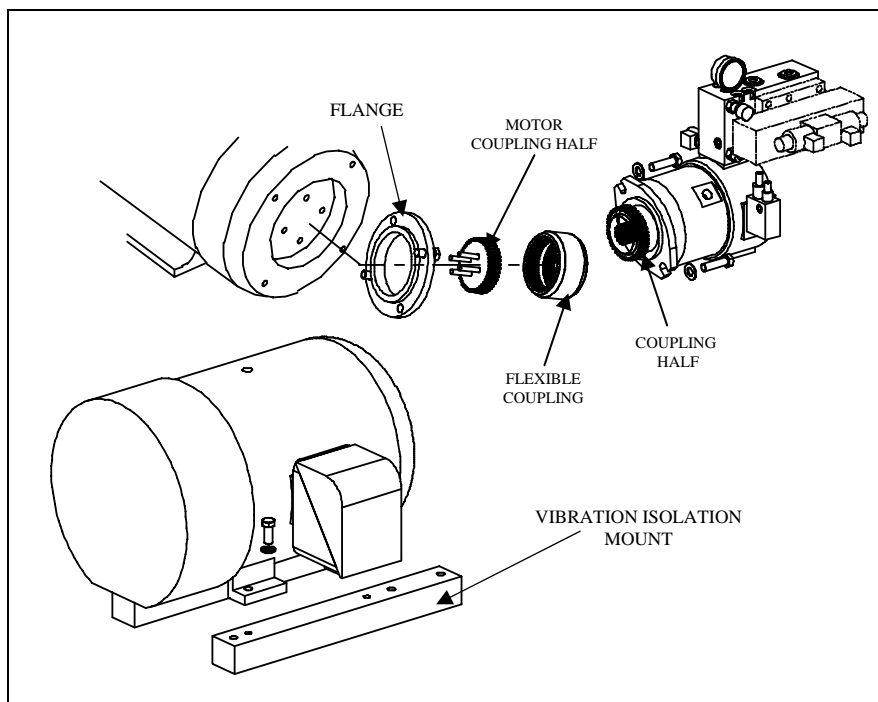
### Motor Maintenance

The motor should be inspected at regular intervals, approximately every 500 hours of operation or every three months, whichever occurs first. Keep the motor clean and the ventilation openings clear.

### Flexible Coupling Replacement

When the flexible coupling fails, the pump shaft will not turn and pressure will not be created. Typically, failure will be sudden, without any warning signs.

**Figure 7-5: Flexible Coupling Replacement**



Severe injury can result if the machine is not properly locked out. Observe electrical Lockout/Tagout procedures before performing maintenance on the system components.

Ensure all pressure is relieved or blocked from the hydraulic and high pressure circuits before performing maintenance.

1. Remove the bolts attaching the motor vibration mounts to the frame base plate.
2. Use wooden blocks to support the hydraulic pump and manifold assembly. Leave all hose connections intact.

**NOTE**

A forklift can also be used by trained, experienced personnel to support the pump and manifold assembly.

3. Remove the bolts attaching the hydraulic pump to the electric motor.
4. Slide the motor away from the pump and manifold assembly to expose the flexible coupling.

**NOTE**

If additional clearance is required to separate the motor and pump, the electrical panel can be removed from the end of the frame. Remove the hex nuts from the studs holding the electrical panel. Move the panel 4-8 inches away from the frame.

It should not be necessary to disconnect the motor lead wires. However, the wire ties holding the electrical control harness to the top pan will need to be removed in order to move the electrical panel.

5. Remove the failed flexible coupling.
6. Wipe any residue, dirt or oil from the coupling halves on both the motor shaft, and the pump shaft. Avoid damaging the shaft seal on the pump.

**NOTE**

Additional clearance and access to the motor and pump coupling can be achieved by moving the pump and manifold assembly to the right. The pump suction hose will limit movement to approximately one inch. It should not be necessary to disconnect any hydraulic hoses.

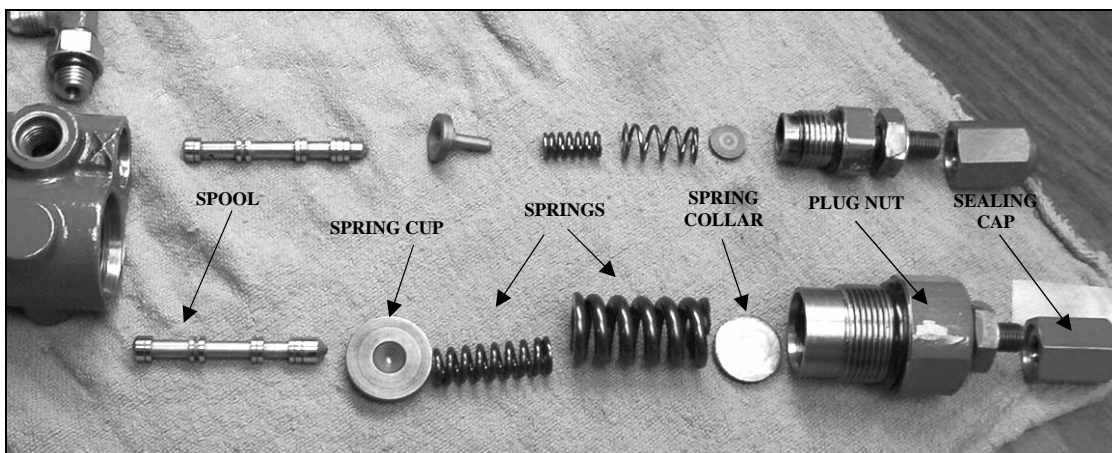
7. Inspect the metal splines on the coupling halves for damage. If damage is detected, replace the coupling half.
8. Inspect the shaft cavity of the hydraulic pump for the presence of hydraulic oil or evidence of hydraulic leaks. If a hydraulic leak is detected, the shaft seal must be replaced.
9. Install the new flexible coupling over the coupling half on the motor shaft, aligning the splines, and push the flexible coupling on as far as it will go. The internal ring or snap ring keeps the coupling centered between the motor and pump shafts.

10. Move the motor and pump assembly together to re-engage the flexible coupling with the coupling half on the pump shaft. You may need to turn the motor shaft to align the splines with the pump shaft. When the motor and pump are rejoined, the coupling will have a small amount of end clearance to allow the coupling to float.
11. Attach the pump to the motor by reinstalling the bolts, and remove the wooden blocks.
12. Reinstall the vibration mounts to the frame base plate.
13. Reinstall the electrical panel to the end of the frame, if necessary.
14. Start the motor and apply full high pressure water pressure. Note any unusual sounds from the motor or pump assembly.

### Hydraulic Compensator Maintenance

The high and low limit compensators regulate the flow of hydraulic fluid to the system. The compensators can become blocked with debris resulting in loss of pump control.

*Figure 7-6: Hydraulic Compensator Components*

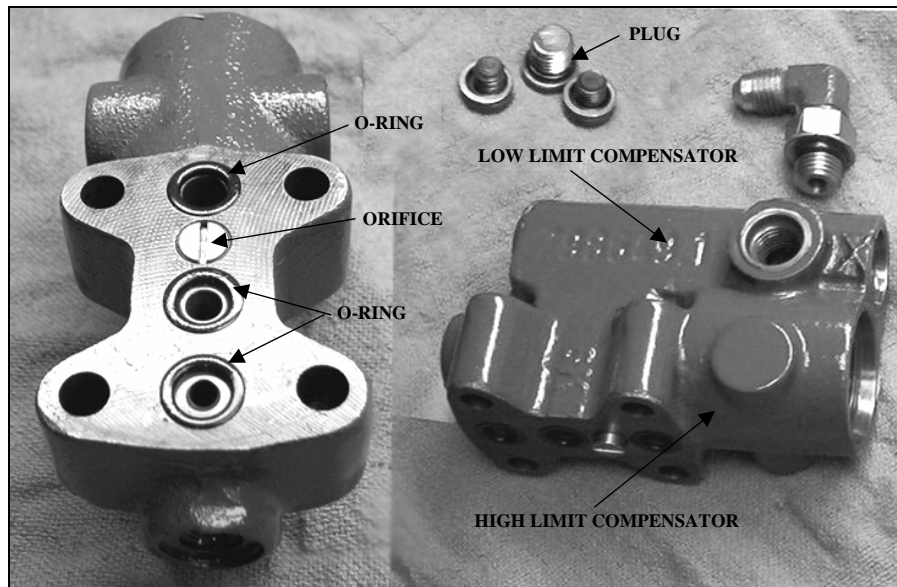


Severe injury can result if the machine is not properly locked out. Observe electrical Lockout/Tagout procedures before performing maintenance on the system components.

Ensure all pressure is relieved or blocked from the hydraulic and high pressure circuits before performing maintenance.

1. Remove the hydraulic hose from the low limit compensator.
2. Remove the four socket screws that attach the compensators to the pump.

3. Remove the compensators and then remove the three plugs and o-rings on the back of the housing.

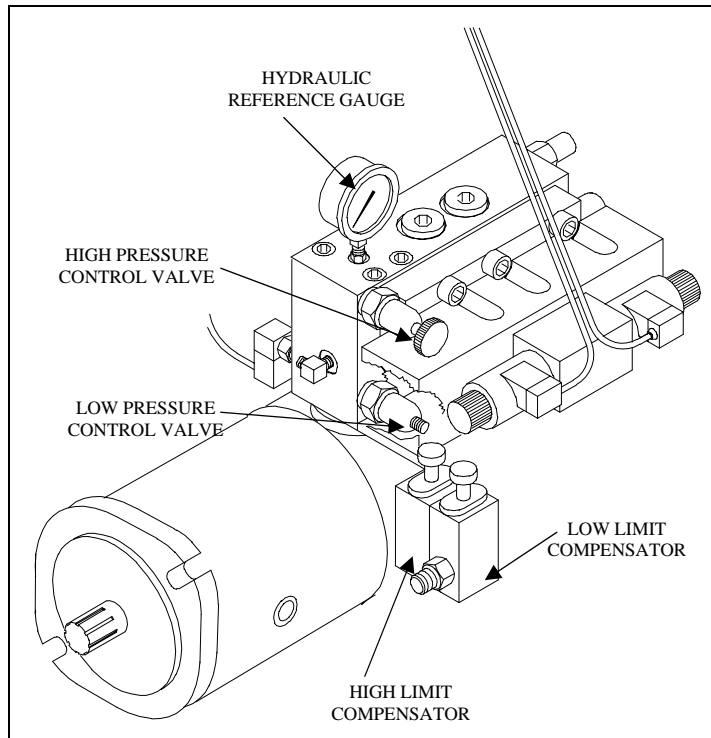


4. Disassemble the compensators one at a time by first removing the hexagon sealing cap.
5. Loosen the lock nut, and then remove the plug nut.
6. Disassemble the plug by removing the spring collar, springs, spring cup and spool.
7. Clean the housing and all components with clean fluid and carefully dry with air.
8. Check and clean the small internal passages in the spools.
9. Check and clean the orifices in both spools.
10. Assemble in the reverse order, ensuring that the screw slot on the orifice is aligned with the long axis of the body.



When the compensators are removed, the machine loses adjustment. The compensators must be reset before operation can begin.

11. Start the machine and select the low pressure operating mode on the display panel.
12. Deadhead the machine.



13. Set the high and low pressure control valves on the hydraulic manifold to the minimum setting by turning them counter-clockwise.

If the machine is equipped with proportional pressure control, adjust the high pressure setting on the Pressure Control Screen.

14. Set the compensators to the minimum setting by turning the adjusting screws counter-clockwise.
15. Select high pressure operating mode on the display panel and set the high pressure control valve on the hydraulic manifold to the maximum setting by turning the knob clockwise.  
  
If the machine is equipped with proportional pressure control, adjust the high pressure setting on the Pressure Control Screen.
16. Turn the adjusting screw on the high limit compensator clockwise until the hydraulic reference gauge reads 2,900 psi (200 bar).
17. Select low pressure operating mode on the display panel and turn the adjusting screw on the low limit compensator clockwise until the reference gauge reads 290 psi (20 bar). Lock the adjustment screw in place.
18. Select high pressure operating mode on the display panel and turn the knob on the high pressure control valve counter-clockwise until the reference gauge reads 2,815 psi (194 bar).

If the machine is equipped with proportional pressure control, adjust the high pressure setting on the Pressure Control Screen.

19. Open the high pressure water control valve, allowing water to flow. Set the desired high operating pressure by adjusting the high pressure control valve.

If the machine is equipped with proportional pressure control, select the high operating pressure on the Pressure Control Screen.

20. While the machine is running and high pressure water is flowing, select low pressure operating mode. Set the desired low operating pressure by adjusting the low pressure control valve.

## **Hydraulic Pump or Electric Motor Replacement**

The following procedures are used to replace the hydraulic pump or the electric motor.

### ***Hydraulic Pump Replacement***

1. Turn the machine off and observe the appropriate Lockout/Tagout procedures.



Severe injury can result if the machine is not properly locked out. Observe electrical Lockout/Tagout procedures before proceeding.

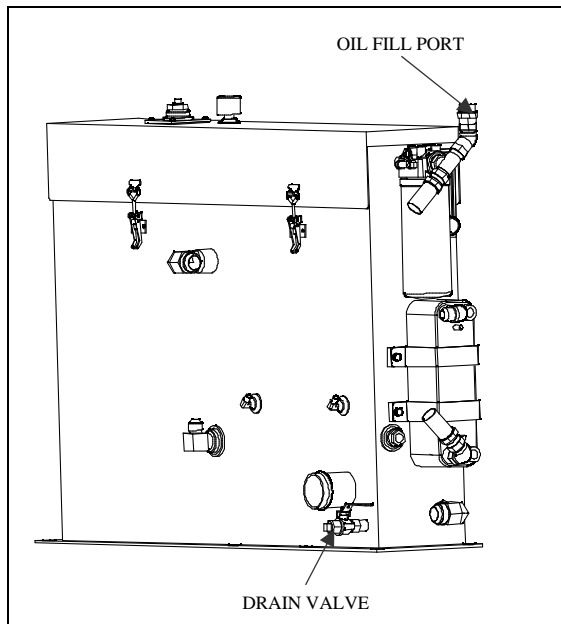
Ensure all pressure is relieved or blocked from the hydraulic and high pressure circuits before proceeding.

2. Loosen the hold down screws on the proximity switches to allow the hydraulic oil in the cylinders and hoses to drain back to the reservoir. It will take approximately five minutes for the oil to drain.
3. Drain the oil reservoir by connecting the inlet hose from an oil transfer pump to the drain valve on the reservoir. Open the shut off valve on the drain and pump the used oil out to a container. Close the shut off valve and remove the inlet hose from the drain valve.



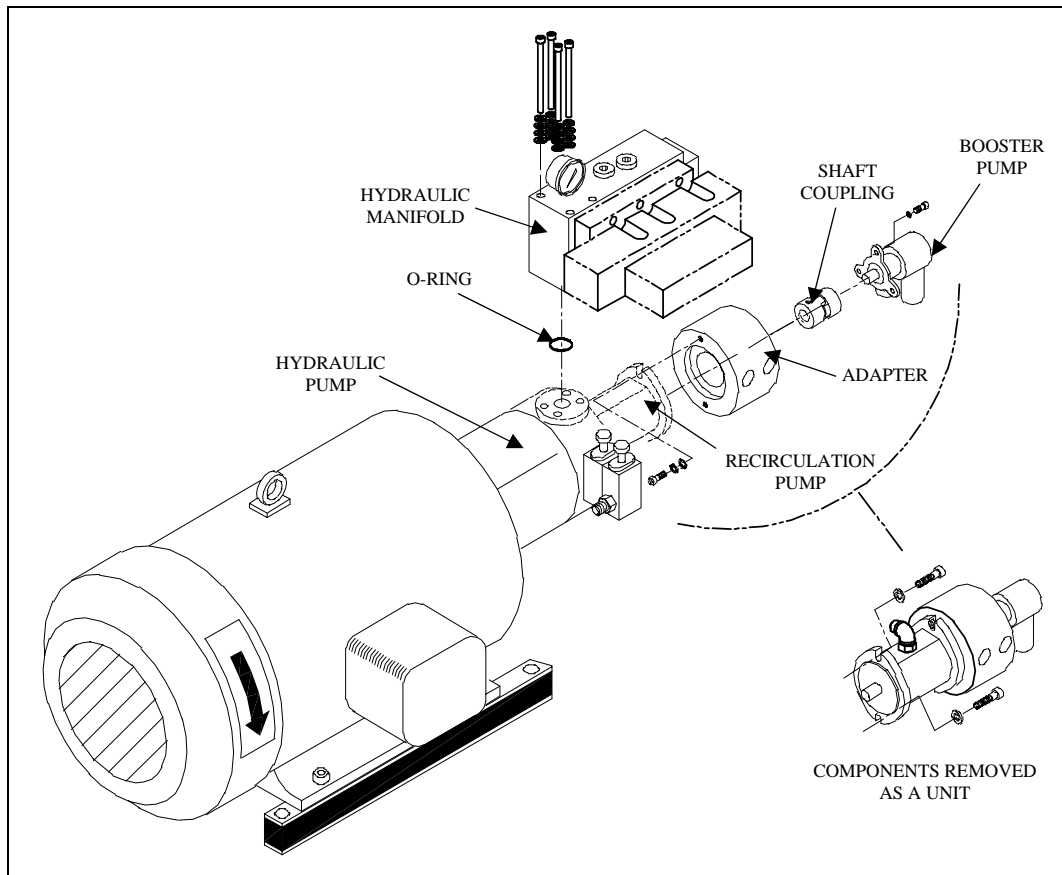
The removed oil should not be reused. It is recommended that the empty reservoir be flushed with a few gallons of clean oil to remove settled debris from the bottom of the reservoir.

**Figure 7-7: Hydraulic Reservoir**



4. Disconnect all hydraulic hoses and connections to the case drain, hydraulic pump, hydraulic manifold and recirculation pump.
5. Loosen the hydraulic gauge and turn it out of the way. Remove all electrical sensors and connections to the hydraulic manifold.
6. Remove the four bolts on the top of the hydraulic manifold and remove the manifold and o-ring.
7. Remove the booster pump, adapter and recirculation pump. These components can be removed individually or as a unit by removing the two bolts that attach the recirculation pump to the hydraulic pump.

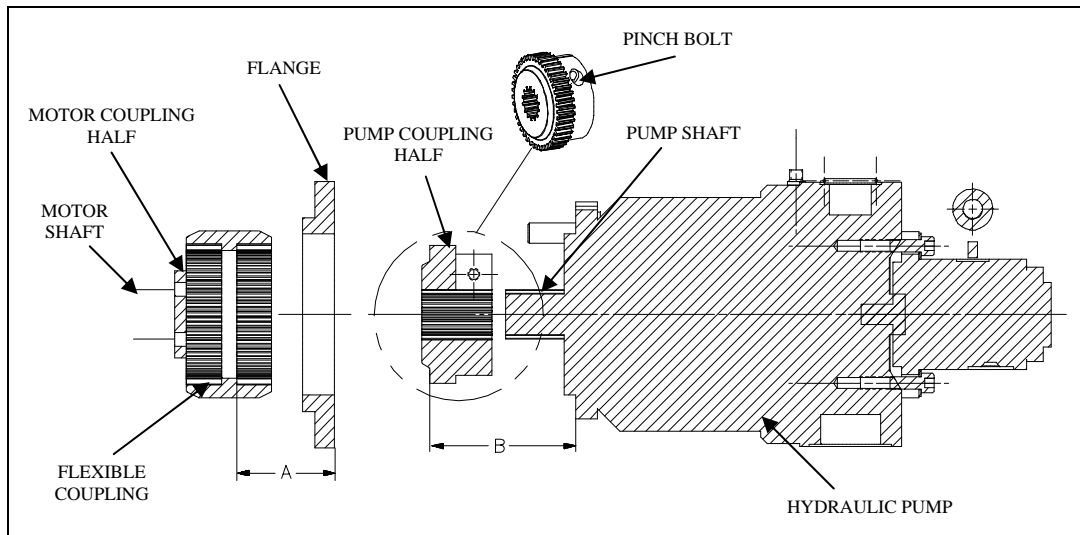
Figure 7-8: Component Removal



8. Remove the bolts that attach the hydraulic pump to the electric motor.
9. Support the hydraulic pump and slide it away from the motor, disengaging the flexible coupling.
10. Inspect the flexible coupling for damage. If the flexible coupling is damaged it must be replaced.
11. Inspect the metal splines on the motor coupling half. Wipe any residue, dirt or oil from the motor coupling and the flexible coupling. Place the flexible coupling on the motor coupling half, pushing it on as far as it will go.
12. Take a measurement from the front face of the electric motor, the pump mounting interface, to the outer face of the snap ring or solid band on the flexible coupling, dimension A.



Figure 7-9: Pump Coupling Dimension



From dimension A, subtract 1/4 inch.

13. Loosen the pinch bolt in the pump coupling half on the old pump and remove the coupling half. Inspect the metal splines for damage. If the coupling half is not damaged it can be reused on the new pump.

14. Wipe any residue, dirt or oil from the pump coupling half. Slide the existing coupling half, or a new coupling half if necessary, onto the splined shaft of the new pump.

Set the position of the pump coupling half by measuring from the pump mounting face to the outer face of the coupling teeth, dimension B. On 100 horsepower models  $B = (A - 0.250)$ .

15. Tighten the pinch bolt and torque to 218 ft-lbs (295 Nm).
16. Place the hydraulic pump on the motor, ensuring the coupling teeth mesh into the flexible coupling. Force should not be required.
17. Verify that the mating surfaces of the motor and pump meet without resistance from the coupling.
18. Replace the pump mounting bolts and torque to the specifications in Table 7-3, Torque Specifications.
19. Install the recirculation pump, adapter and booster pump.
20. Install the hydraulic manifold ensuring that the o-ring is properly positioned. Torque the mounting bolts to the specifications in Table 7-3.
21. Reconnect all hydraulic hoses, connections and electrical sensors.

22. Tighten the hold down screws on the proximity switches and torque to 140-160 in-lbs (16-18 Nm).



Ensure that the proximity switches are properly installed and secured prior to starting the motor. Failure to tighten the two hold down screws on each switch will result in the spray of hydraulic oil.

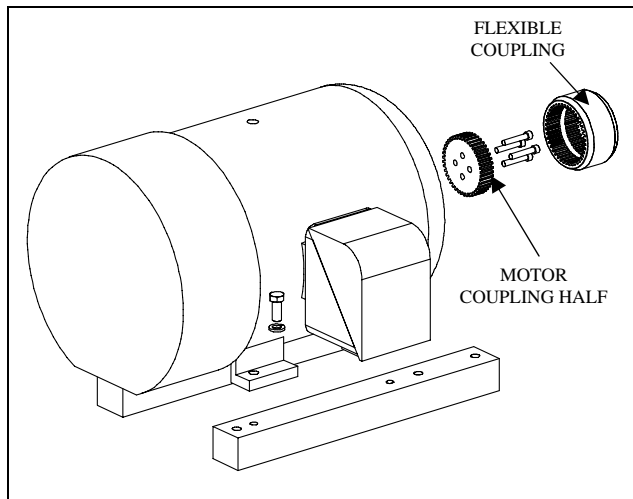
23. Refill the hydraulic reservoir following the procedure, Hydraulic Oil Replacement.
24. Start the motor and apply full high pressure water pressure. Inspect for hydraulic leaks and note any unusual sounds from the motor or pump assembly.

**Table 7-3**  
**Torque Specifications**

Pump mounting bolts	200 ft-lb (271 Nm)
Manifold mounting bolts	45 ft-lb (61 Nm)
Motor coupling half bolts	85 ft-lb (115 Nm)

### ***Electric Motor Replacement***

1. Complete Steps 1-10 in the previous procedure.
2. Open the junction box on the motor and remove all electrical leads. Loosen the lock nut, disconnect and remove the flexible electrical cable from the junction box.
3. Remove the bolts attaching the motor to the vibration isolation mounts and remove the old motor from the frame.
4. Stand the new motor on the fan cowl with the shaft pointing upward.

**Figure 7-10: Motor Coupling Half**

5. Apply Loctite 222 to the bolts and attach a new motor coupling half to the motor shaft. Torque to the specifications in Table 7-3.
6. Place the flexible coupling on the motor coupling half. Follow Step 12 and 14 in the previous procedure to determine if the coupling half on the hydraulic pump is in the proper position. If necessary, adjust the position of the pump coupling half.
7. Place the hydraulic pump on the motor, ensuring the coupling teeth mesh into the flexible coupling. Force should not be required.
8. Verify that the mating surfaces of the motor and pump meet without resistance from the coupling.
9. Replace the pump mounting bolts and torque to the specifications in Table 7-3.
10. Position the motor and hydraulic pump in the frame. Attach the motor to the vibration isolation mounts.
11. Install the flexible electrical cable on the junction box and replace the electrical leads.
12. Complete Steps 19-24 in the previous procedure.

## Hydraulic Oil Replacement

Hydraulic oil **must only** be removed and replaced at the fill port on the filter head.

1. Remove the cap from the fill port on the oil filter.



To ensure cleanliness, the oil fill port **must** be used to pump oil into the reservoir. Filling at this point guarantees the hydraulic oil will pass through the oil filter before entering the reservoir.

2. Connect the discharge hose from an oil transfer pump to the fill port and pump the fresh oil into the reservoir.

### NOTE

Oil from a new drum does not meet the cleanliness requirements of the hydraulic system. For this reason, it is important to use an oil transfer pump that will force oil through the return filter into the reservoir.

3. Check the oil sight gauge on the reservoir to ensure proper fill level.
4. Remove the hose from the case drain on the main hydraulic pump to make sure the pump case fills with oil. With the hose removed, head pressure from the reservoir will force oil into the pump case.



Oil in the pump case provides internal lubrication for the main hydraulic pump. Failure to fill the pump case with oil will allow air to become trapped inside, damaging the pump.

5. Disconnect the discharge hose from the fill port and replace the fill port cap.
6. Follow the initial startup sequence in Section 4, Operation, to ensure the system fills with oil.
7. Check the sight gauge again and follow the same procedure to add additional oil if necessary.



## **SECTION 8**

### **ELECTRICAL SYSTEM**

#### **8.1 Overview**

All SL-V SRP 100 intensifier is equipped with integral motor starter and control circuitry, enclosed in the electrical panel. The operator controls the machine primarily through a touch-screen control panel that communicates with the programmable logic controller (PLC). A series of sensors provide automatic shutdown logic and diagnostics.

Major system components include the electric motor, control panel, high voltage and control components, and the wiring harness that connects the sensors and solenoid valves to the PLC.

#### **8.2 Optional System Components**

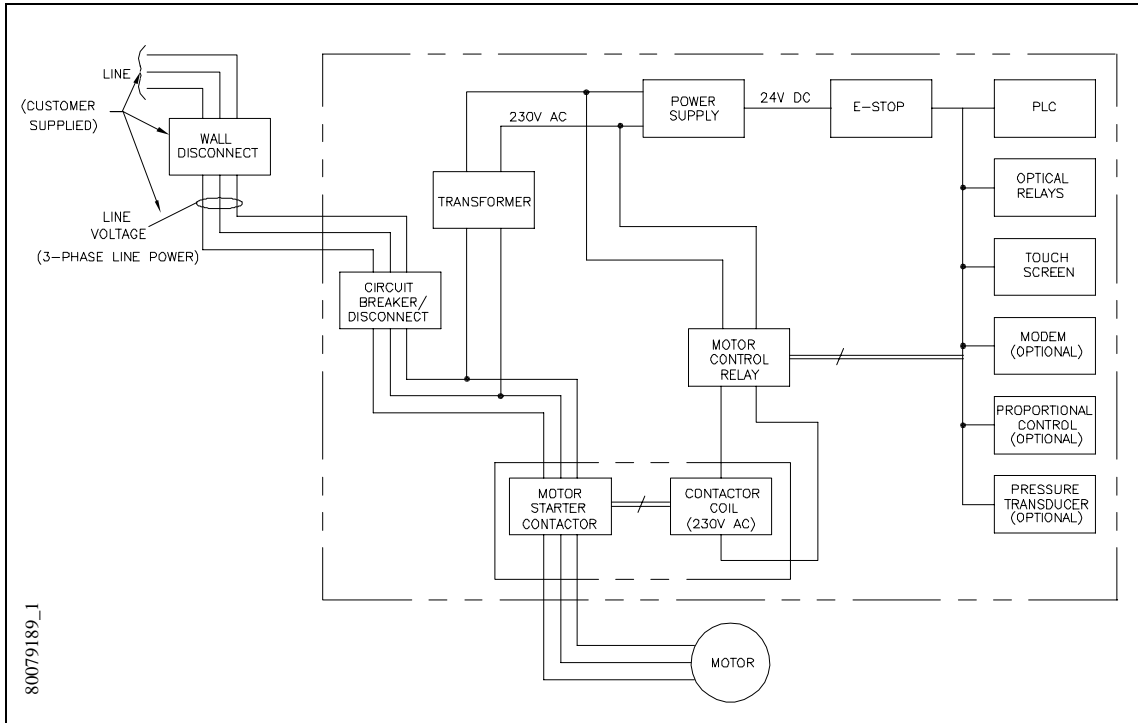
The following system options are available at the time of purchase, or as upgrade kits for existing equipment.

- A pressure transducer allows the operating pressure to be viewed from the display panel.
- Proportional pressure control allows the operator to select or vary the hydraulic operating pressure from the control panel or from a remote console.
- A modem option permits remote monitoring for troubleshooting and software updates.
- A 37-pin amphenol connector, mounted in the side of the electrical enclosure, is available for all remote connections.

### 8.3 Operation

Electrical power from the utility grid enters the main circuit breaker/disconnect on the electrical enclosure door as 3-phase alternating current. The power is then distributed in two directions. The 3-phase AC, at the voltage provided from the grid, is routed to the motor starter contactors and then to the main motor. Single phase AC is routed to the transformer.

**Figure 8-1: Electrical Control Power**

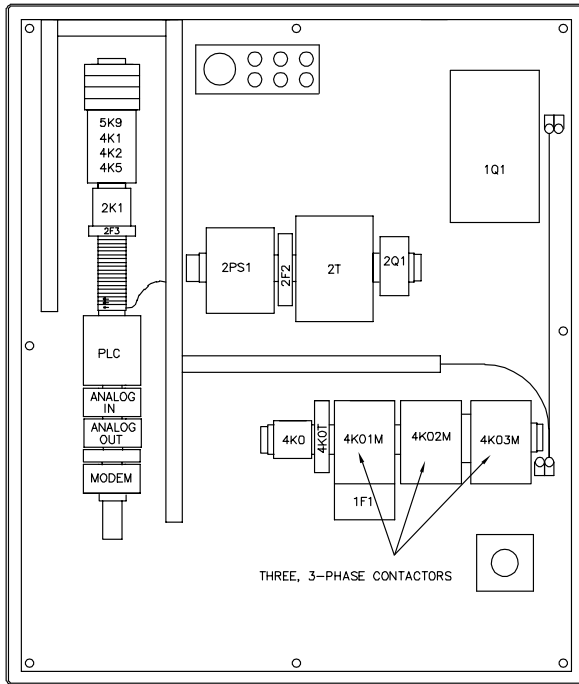


The multi-tap transformer converts the incoming voltage to 230 volt AC that is routed to both the motor starter contactors and to the power supply. The power supply then provides 24 volt direct current to the control circuits, including the emergency stop logic, the programmable logic controller (PLC), optical relays, display screen and optional control functions.

When the START button is pressed on the control panel, the motor control relay closes and 230 volt AC power is sent to the contactor coils. The coils close, sending the incoming power to the motor. When the STOP button is pressed, the motor control relay opens, disconnecting power to the contactor coils, stopping the motor.

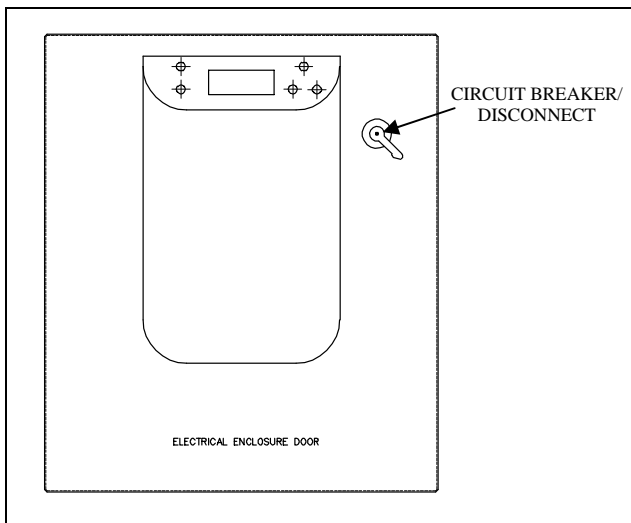
The motor starter contactors are solenoid operated by 230 volt AC control power. The contactors are arranged in a wye-delta starter circuit. Wye-delta starter circuits consist of three, 3-phase contactors used to start the motor slowly, minimizing the initial current draw.

Figure 8-2: Wye-Delta Configuration



The circuit breaker/door disconnect provides the primary over current protection for the machine. All power is automatically disconnected from the machine when the main disconnect on the enclosure door is opened. However, power is still present on the input side of the circuit breaker/door disconnect. The only way to isolate all power to the machine is to turn the customer installed main power disconnect off.

Figure 8-3: Electrical Enclosure Door



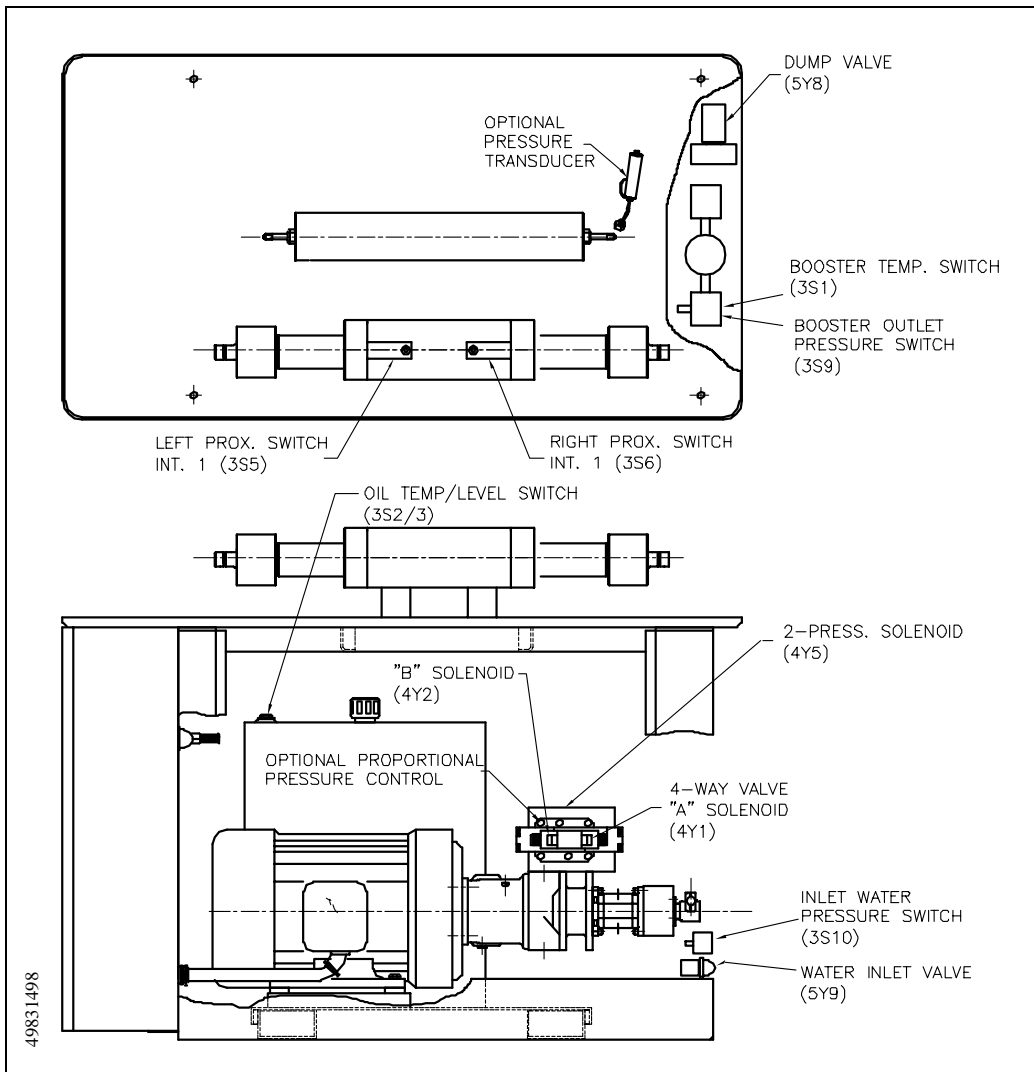
**NOTE**

See Section 2, Installation, regarding specifications for the customer installed main power disconnect.

**Sensors and Solenoids**

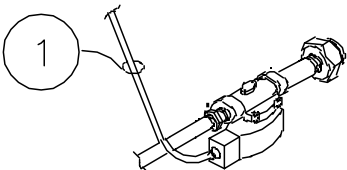
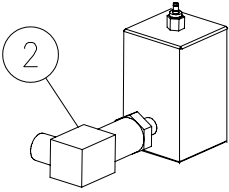
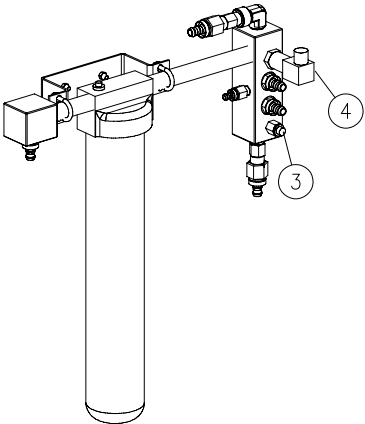
Warning and shutdown sensors monitor operating conditions, and electronically operated solenoids provide basic intensifier shift control. The harness cable connects these sensors and solenoids to the PLC, see Figure 8-5, Electrical Harness.

*Figure 8-4: Sensors and Solenoids*

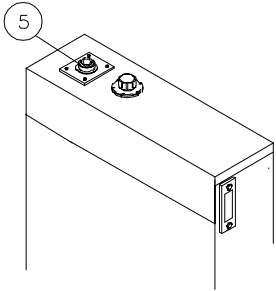
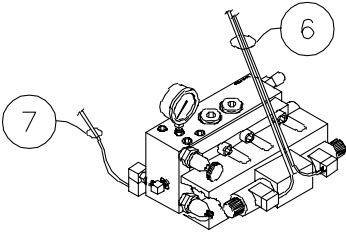




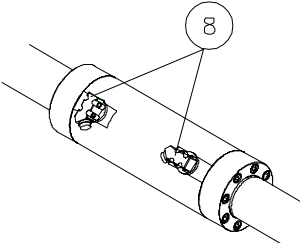
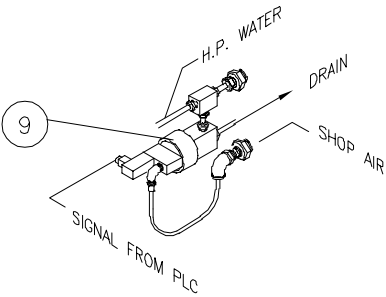
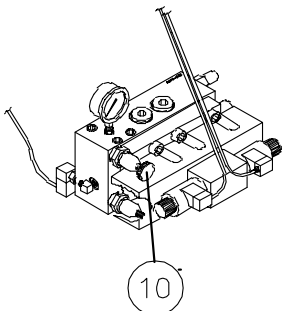
**Table 8-1**  
**Sensors and Solenoids**

Component	Function
<p><i>Inlet Water Solenoid Valve</i></p> 	<p>1 The normally closed, inlet water solenoid valve is located at the service bulkhead. When the control power is turned on, the valve opens and allows low pressure cutting water to enter. The solenoid valve functions as a safeguard by closing if a leak is detected anywhere in the system, or if the system is idle for an extended period.</p> <p>The operator can adjust the idle closing time from 5 to 60 minutes. The function can also be disabled so the valve stays open whenever the control power is on.</p>
<p><i>Low Pressure Water Filter Assembly</i></p> 	<p>2 The 30 psi pressure switch, mounted on the inlet manifold, monitors the inlet cutting water. If the pressure drops below 30 psi (2 bar) the switch activates an automatic shutdown circuit, protecting the booster pump from damage due to insufficient water supply pressure.</p>
	<p>3 A temperature switch monitors the temperature of the cutting water from the booster pump. If the temperature exceeds 128° F (53° C), the switch activates an automatic shutdown circuit in the PLC. The temperature switch prevents booster pump overheating due to lack of water, long deadhead conditions or a blocked orifice.</p> <p>4 The discharge pressure is monitored by a 30 psi pressure switch. An automatic shutdown occurs if the pressure is below 30 psi (2 bar).</p>

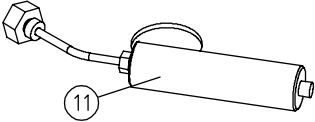
**Table 8-1**  
**Sensors and Solenoids**

Component	Function
<p><i>Hydraulic Reservoir</i></p> 	<p>5 The temperature/low level switch monitors the oil temperature and level in the reservoir. Although the float switch and the temperature switch are combined in a single unit, the two switches function independently.</p> <p>If the operating oil temperature exceeds 144° F (62° C) an automatic shutdown occurs. If the hydraulic fluid level falls below specifications, a low oil level shutdown occurs.</p>
<p><i>Hydraulic Manifold</i></p> 	<p>6 The 4-way directional control valve shifts the hydraulics back and forth to the intensifier. A shift valve directs pressurized oil to one end of the hydraulic cylinder and returns fluid to the reservoir from the opposite end, causing the intensifier to stroke. The movement is controlled hydraulically by a pilot valve that is electronically operated by two solenoids, energized by the PLC. As power is directed from one solenoid to the other, LEDs are alternately illuminated.</p> <p>7 When low pressure is selected, a normally closed, solenoid valve is activated. The valve remains closed while operating in high pressure and is held open electrically during low pressure operation. An illuminated LED on the solenoid indicates low pressure operation.</p>

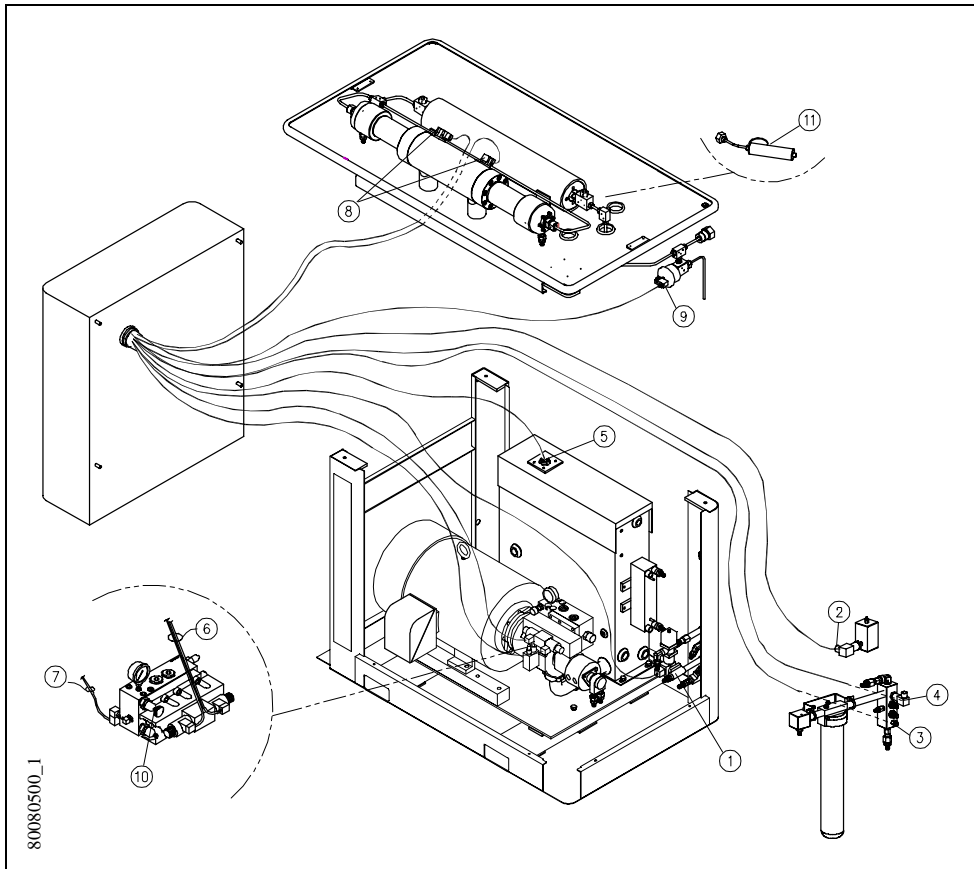
**Table 8-1**  
**Sensors and Solenoids**

Component	Function
<i>Hydraulic Cylinder</i>	<p>8 As pressurized hydraulic oil is sent to one side of the hydraulic cylinder, it pushes against the piston, moving it in one direction until it activates the proximity switch at the end of the stroke. The hydraulic flow is then sent to the opposite side of the cylinder, and the piston reverses direction until it activates the proximity switch at the opposite end of the stroke.</p>
	<p>The green light on the proximity switch indicates there is power to the switch. The light turns red when the switch is activated. The proximity switches are magnetically activated by the presence of the metallic surface of the piston. When the switch is activated, it sends a signal to the PLC to change the flow of the directional control valve and reverse direction.</p>
<i>High Pressure Safety Dump Valve</i>	<p>9 When control power is removed, the safety dump valve releases the stored pressure in the intensifier and high pressure delivery lines. The high pressure dump valve assembly includes a normally open high pressure water valve and a solenoid operated air valve.</p>
	<p>The normally open pneumatic dump valve is held closed by air pressure. When the air supply is interrupted from an emergency stop, the valve opens and allows water to flow through the valve. Pressure is released in the intensifier and the high pressure water stream exits through the drain.</p>
<i>Proportional Pressure Control</i>	<p>10 Optional proportional pressure control allows the operator to select or vary the hydraulic operating pressure from the control panel or from a remote console. An electronically controlled hydraulic cartridge valve, mounted on the hydraulic manifold, receives a signal from the PLC and automatically makes the operator selected adjustments.</p>
	

**Table 8-1**  
**Sensors and Solenoids**

Component	Function
<i>Pressure Transducer</i>	
	<p>11 The optional pressure transducer reads the output pressure from the attenuator in the high pressure system. A signal is sent to the PLC module that allows the operating pressure to be viewed from the control panel.</p>

**Figure 8-5: Electrical Harness**



## 8.4 Service and Maintenance Procedures

Electrical components require minimal service. The proximity switches on the hydraulic cylinder and the optical relay switches in the controls subassembly may require replacement.

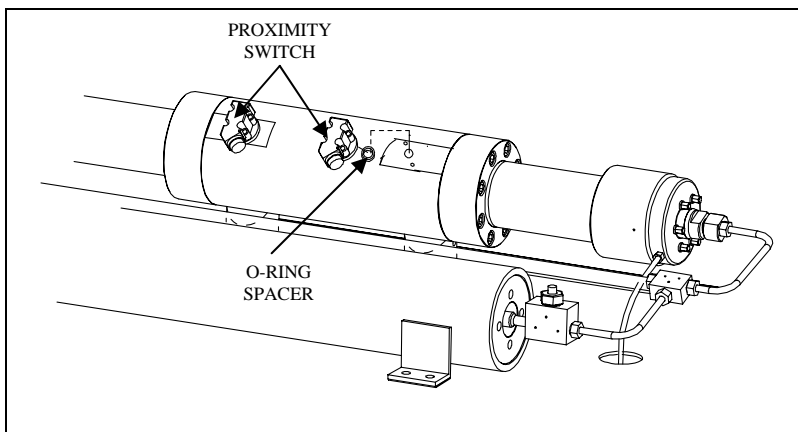
### NOTE

Refer to Section 12, Parts List for a complete listing of replacement parts and part numbers.

### Proximity Switch Maintenance

A proximity switch has failed and needs to be replaced if the LEDs do not change state, indicating they are not sensing the piston, if an LED flashes continuously, or if the appropriate input is not noted on the PLC processor annunciator light panel in the electrical enclosure.

*Figure 8-6: Proximity Switch*



1. Turn the machine off and observe the appropriate Lockout/Tagout procedures.



Severe injury can result if the machine is not properly locked out. Observe electrical Lockout/Tagout procedures before performing maintenance on the system components.

Ensure all pressure is relieved or blocked from the hydraulic and high pressure circuits before performing maintenance.

2. Remove the electrical cable from the failed proximity switch.
3. Remove the two socket head screws, the failed switch and the o-ring spacer.

4. Install a new proximity switch by positioning the o-ring spacer and the switch. Ensure the o-rings are correctly oriented.
5. Apply JL-M grease to the threads on the screws and tighten to 140-160 in-lbs (16-18 Nm).



Ensure that the proximity switch is properly installed and secured prior to starting the machine. Failure to tighten the two hold down screws on each switch will result in the spray of hydraulic oil.

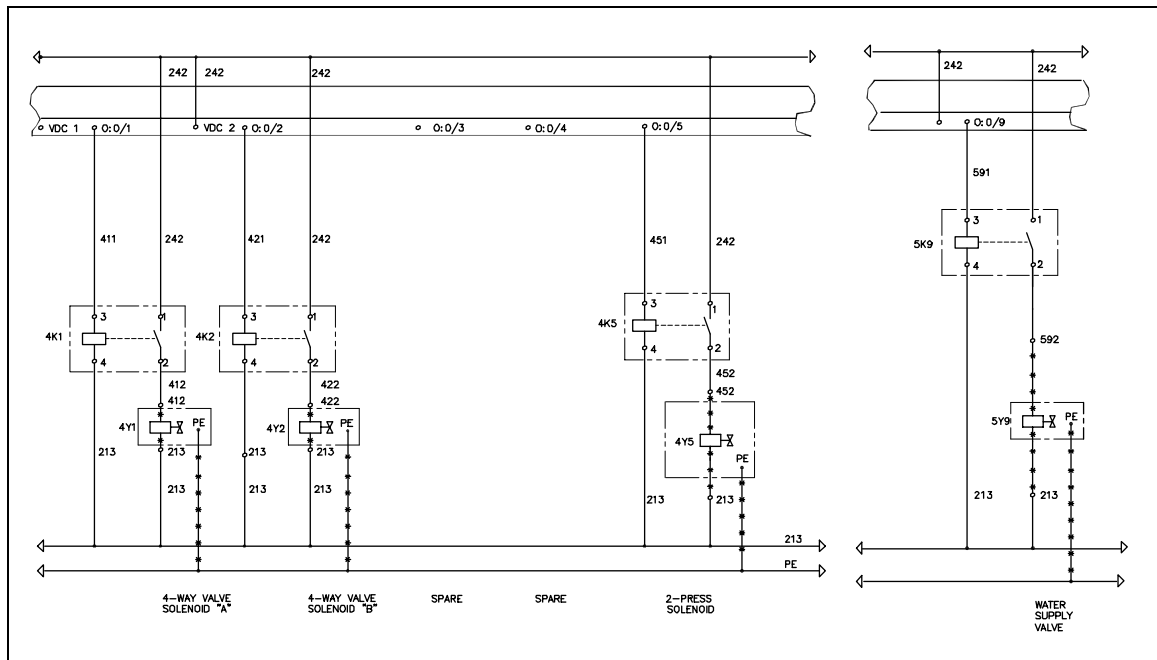
### Optical Relay Maintenance

The four optical relays identified in Table 8-2 change the state of the associated solenoid valves. If the relay or the fuse for the relay fails, the state will not change. For example, if the relay controlling the two-pressure solenoid valve fails, the machine will not switch between low and high pressure operation.

**Table 8-2**  
**Optical Relays**

<b>Label</b>	<b>Component</b>	<b>Function</b>
4K1	Directional Control Valve, Solenoid A	Switches the direction of the hydraulic flow
4K2	Directional Control Valve, Solenoid B	Switches the direction of the hydraulic flow
4K5	Two Pressure Solenoid Valve	Switches to low or high pressure operation
5K9	Water Supply Valve	Opens and closes the inlet water solenoid valve

Figure 8-7: Optical Relays



1. Turn the machine off and observe the appropriate Lockout/Tagout procedures.



Severe injury can result if the machine is not properly locked out. Observe electrical Lockout/Tagout procedures before performing maintenance on the system components.

Ensure all pressure is relieved or blocked from the hydraulic and high pressure circuits before performing maintenance.

2. Open the control panel and locate the appropriate optical relay.
3. Remove the screws and the relay.
4. Remove and test the fuse. If the fuse has failed, replace it and re-install the existing optical relay.
5. If the fuse is good, replace the optical relay.



## SECTION 9

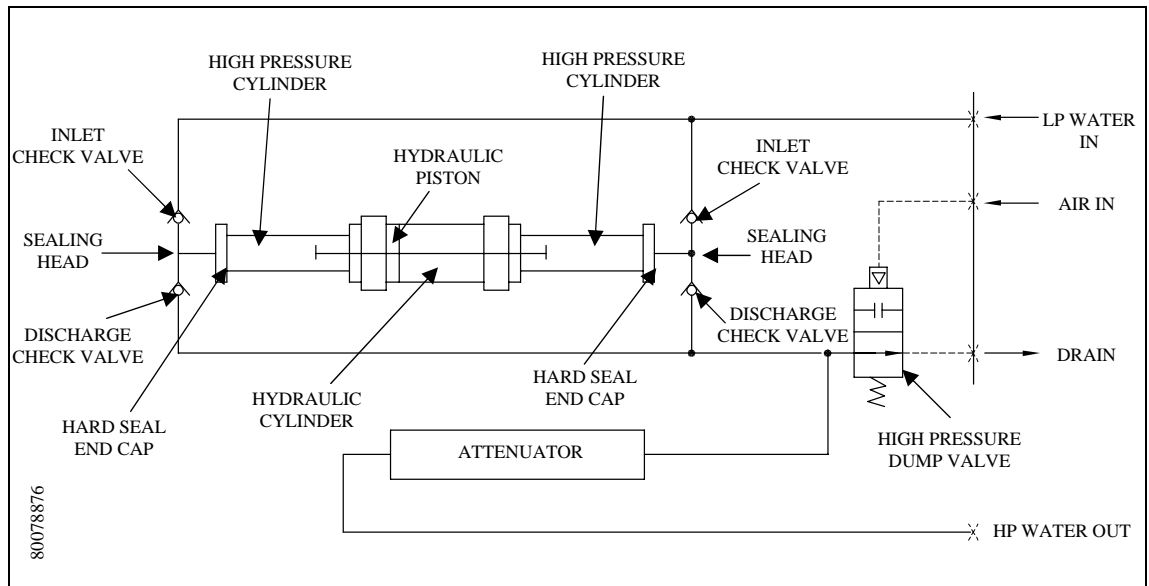
### HIGH PRESSURE WATER SYSTEM

#### 9.1 Overview

The high pressure water system is supported by both the cutting water supply circuit and the hydraulic circuit. Cutting water of sufficient flow and pressure is routed from the cutting water supply circuit to the intensifier where it is pressurized up to 35,000 psi (2,413 bar) and delivered to the cutting head.

The directional control valve in the hydraulic system creates the stroking action of the intensifier by sending pressurized hydraulic oil to one side of the hydraulic cylinder or the other. As the flow is sent to one side, hydraulic fluid is returned to the reservoir from the opposite side.

*Figure 9-1: High Pressure Water System Circuit*



System components include a double-ended hydraulic cylinder; reciprocating piston assembly; high pressure cylinders attached to each end of the hydraulic cylinder; two plungers, sealing heads and hard seal end caps; two liter capacity attenuator, and a safety dump valve. Sophisticated check valves and seal assemblies ensure hydraulic oil, and the low pressure and high pressure water travel in the appropriate direction. Warning and shutdown sensors monitor strategic pressure, temperature and fluid levels to safeguard against component damage.



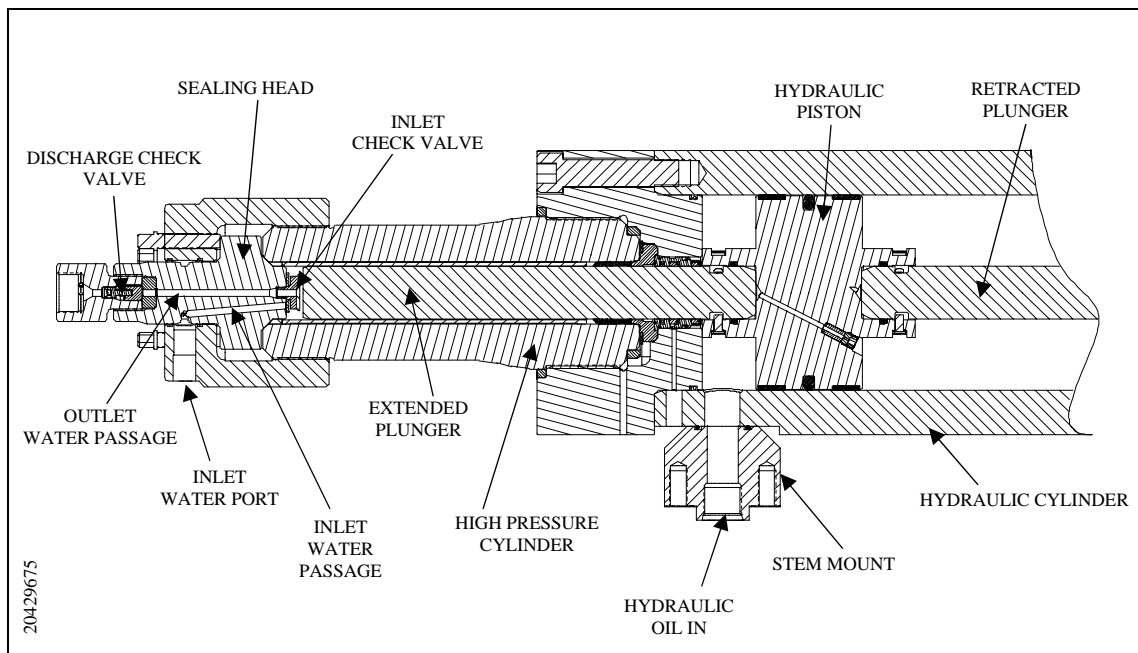
## 9.2 Operation

The directional control valve sends pressurized hydraulic oil to one side of the hydraulic cylinder. The pressurized oil pushes against the piston, moving it in one direction until it activates the proximity switch at the end of the stroke. The hydraulic flow is then sent to the opposite side of the cylinder, and the piston reverses direction until it activates the proximity switch at the opposite end of the stroke.

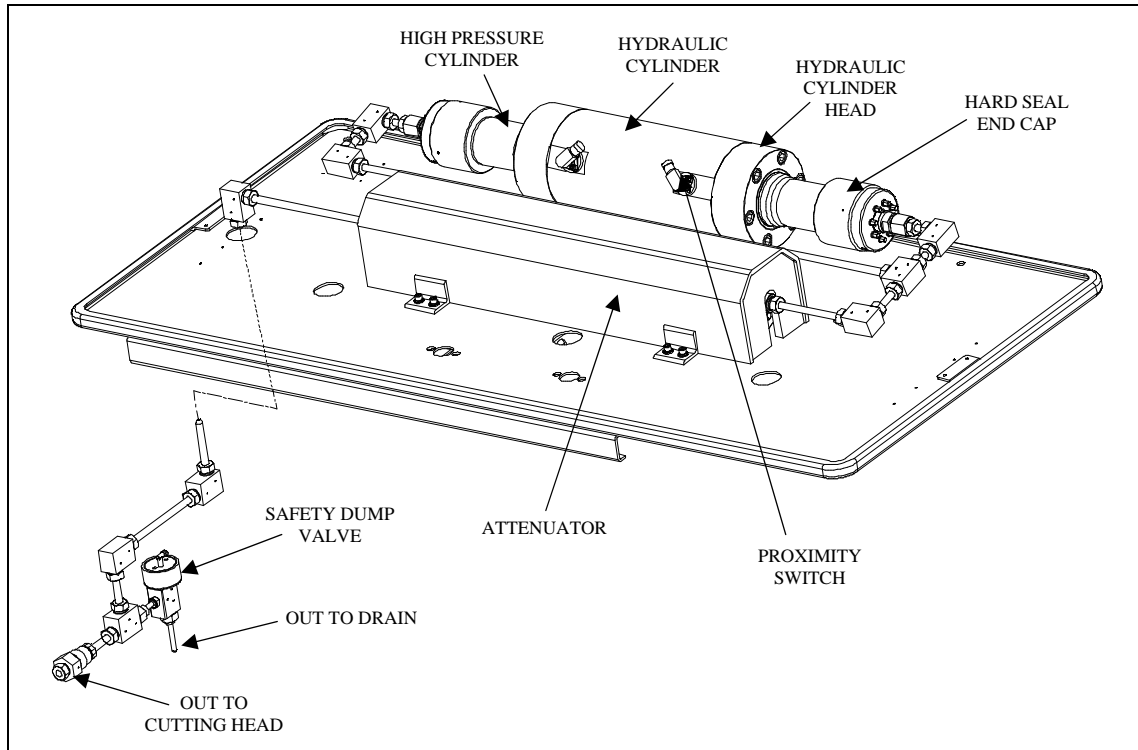
The green light on the proximity switch indicates there is power to the switch. The red light illuminates when the switch is activated. The proximity switches are magnetically activated by the presence of the metallic surface of the piston. When the switch is activated, it sends a signal to the PLC to change the flow of the directional control valve and reverse direction.

As the pressurized oil pushes the piston in one direction, the plunger on that end extends and pushes against the water in the high pressure cylinder, increasing the pressure up to 35,000 psi (2,413 bar). When the piston reverses direction, the plunger retracts and the plunger in the opposite cylinder extends to deliver the high pressure water.

*Figure 9-2: High Pressure Cylinder*



Low pressure water is routed through the inlet water ports to the inlet passages in the sealing heads. When the plunger retracts, the inlet check valve opens to allow water to fill the high pressure cylinder. When the plunger extends to create high pressure water, the inlet valve closes to seal the inlet passage and the discharge check valve opens to allow the high pressure water to exit the cylinder. As the plunger retracts, the discharge check valve closes.

**Figure 9-3: High Pressure Water System**

The intensifier is a reciprocating pump. As the piston and plungers move from one side to the other, high pressure water exits one side of the intensifier as low pressure water fills the opposite side.

The high pressure water is then routed to the attenuator. The attenuator acts as a shock absorber to dampen pressure fluctuations and ensure a steady and consistent supply of water. From the attenuator, the high pressure water exits to the cutting head.

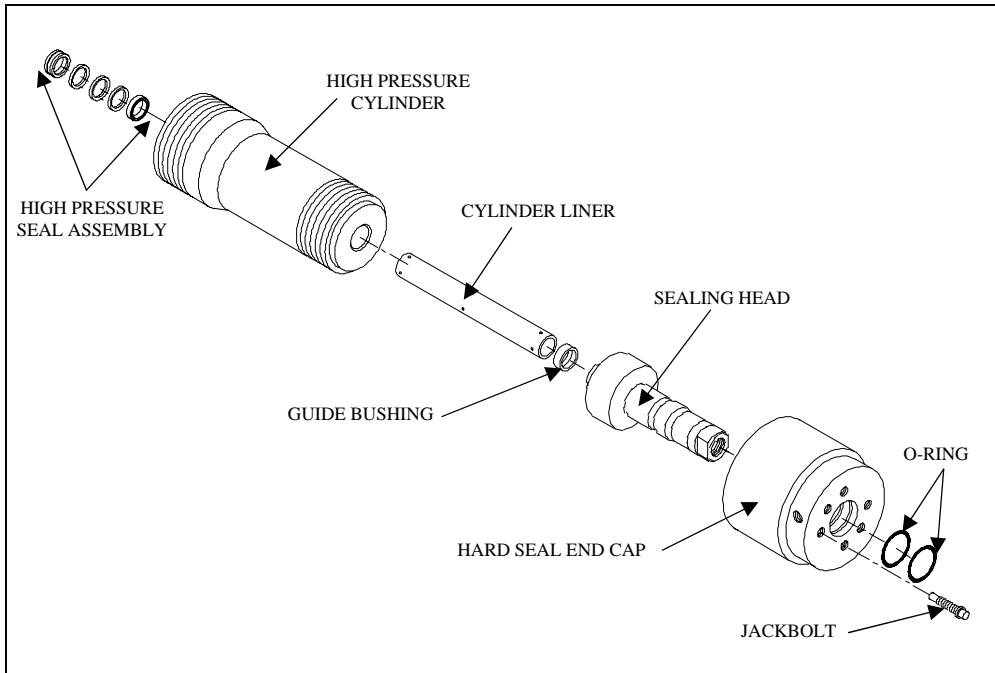
The safety dump valve releases the stored pressure in the intensifier and high pressure delivery lines. The high pressure dump valve assembly includes a normally open high pressure water valve and an electrically controlled air valve.

The normally open pneumatic dump valve is held closed by air pressure. When the air supply is interrupted and exhausted from an emergency stop, the valve opens and allows water to flow through the valve. Pressure is released in the intensifier and the high pressure water stream exits through the drain.

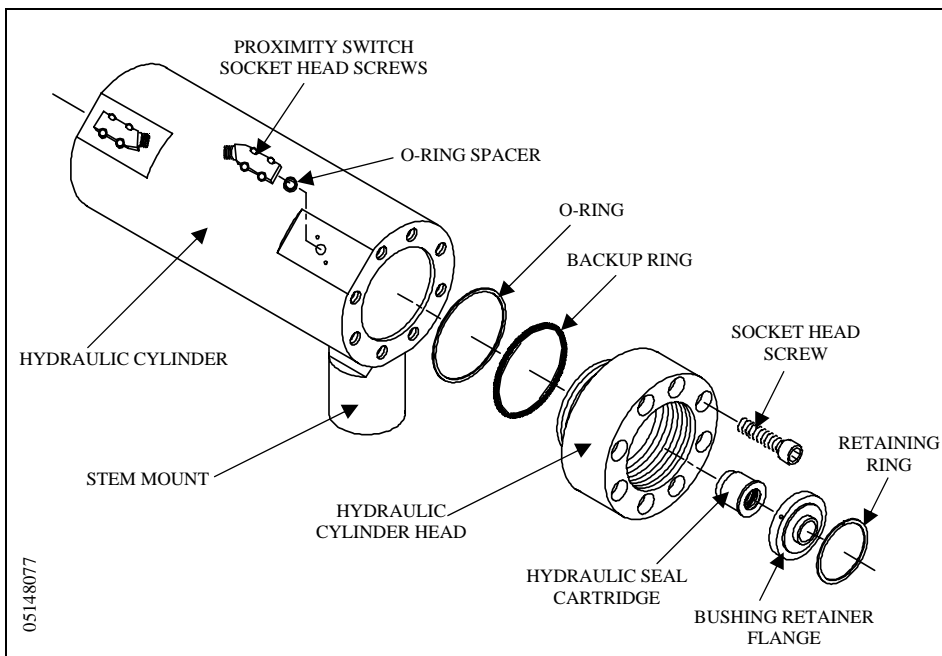
### 9.3 System Components

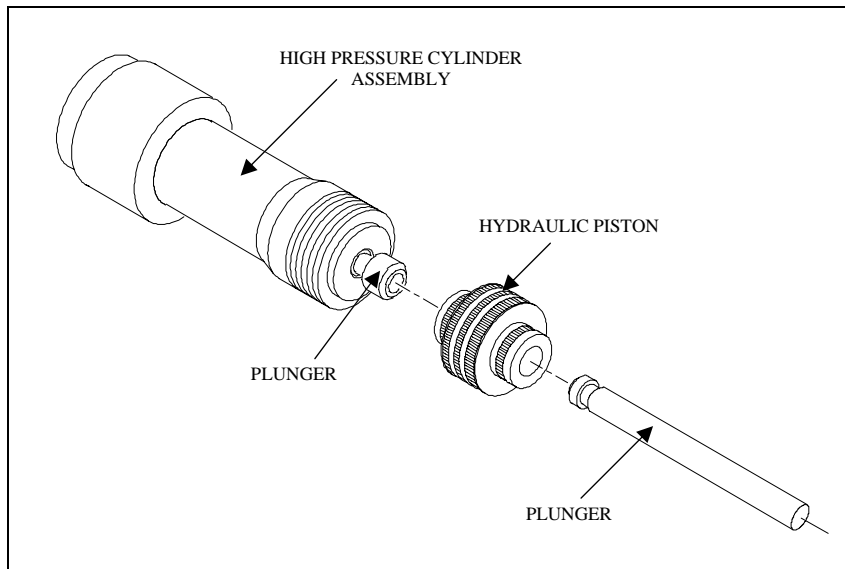
The following figures illustrate the individual high pressure water system components.

**Figure 9-4: High Pressure Cylinder Assembly**



**Figure 9-5: Hydraulic Cylinder Assembly**



**Figure 9-6: Hydraulic Piston**

## 9.4 Service and Maintenance Overview

Never perform any type of maintenance on the high pressure water system while it is pressurized. Always turn the power off and bleed the high pressure water before servicing. Pressing the emergency stop button turns the control power off to the intensifier, and bleeds high pressure water through the dump valve.

Improper assembly can lead to the premature failure of components. Maintenance procedures must be followed carefully; components must be properly cleaned prior to assembly and tightened to the correct torque specifications.

Some high pressure components are not serviceable at the customer level, others require precise refinishing. KMT Waterjet Systems offers maintenance and refinishing services for these components.

### NOTE

Refer to Section 12, Parts List for a complete listing of replacement parts and part numbers.

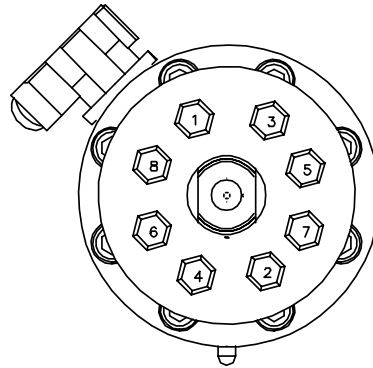
## Torque Specifications

Table 9-2, Torque Specifications, details the torque specifications and tightening sequences for the high pressure components and connections.

**Table 9-2**  
**Torque Specifications**  
**High Pressure Water System**

<b>Hard Seal End Cap</b>	
Jackbolts	8 (7/16") each
1st Stage	Hand Tight
2nd Stage	20 ft-lbs (27 Nm) Crossing Pattern
3rd Stage	32-35 ft-lbs (43-47 Nm)* Crossing Pattern
4th Stage	32-35 ft-lbs (43-47 Nm)* Clockwise Pattern From Bolt 1
Socket Wrench Size	3/8 inch

### 8-Bolt Crossing Pattern



\* **Note:** Crossing Pattern: 1, 2, 3, 4, 5, 6 or 1, 2, 3, 4, 5, 6, 7, 8.

\*\* **Note:** A maximum torque of 38 ft-lbs (51 Nm) is etched on the hard seal end cap. This represents the **maximum** allowable torque, not the recommended torque.

<b>Hydraulic Cylinder Head</b>	
Socket Head Screws	6 (3/4") each
Torque	170-175 ft-lbs (230-237 Nm)
Hex Key	5/8 inch



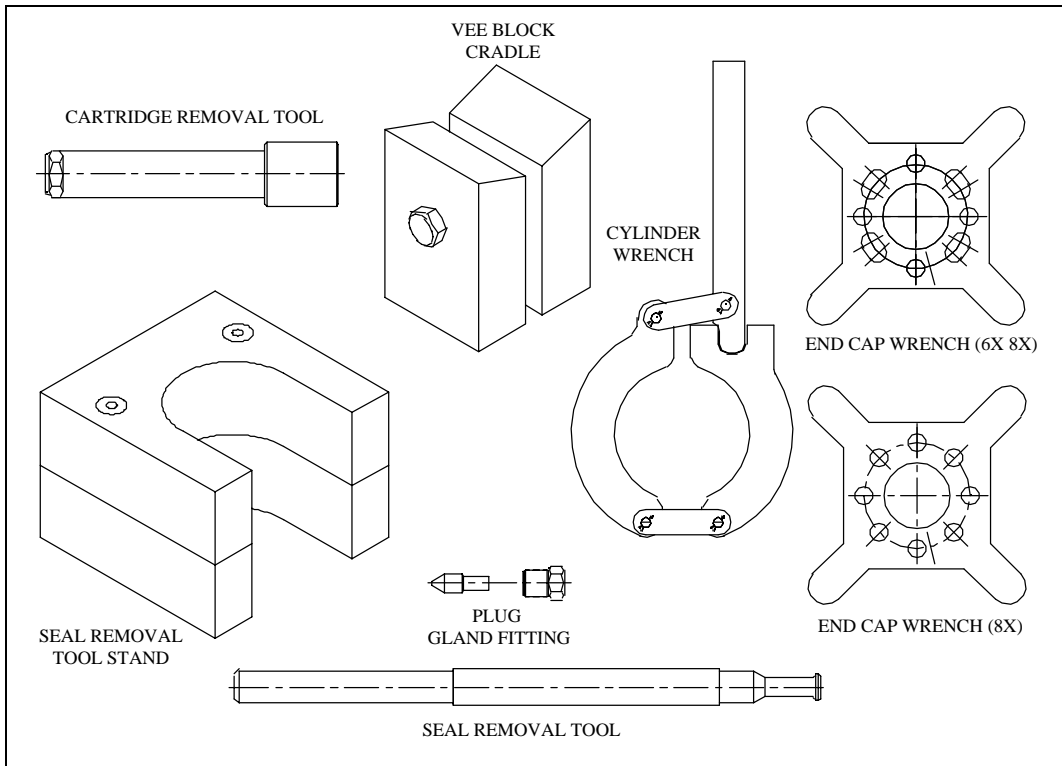
**Table 9-2**  
**Torque Specifications**  
**High Pressure Water System**

<b>Proximity Switch</b>	
Socket Head Screws	2 (1/4") each
Torque	140-160 in-lbs (16-18 Nm)
Hex Key	3/16 inch
<b>Stem Mount</b>	
Socket Head Screws	4 (3/8") each
Torque	35-40 ft-lbs (47-54 Nm)
Hex Key	5/16 inch
<b>Sealing Head</b>	
Discharge Gland Nut	200 ft-lbs (271 Nm)
Poppet Retainer	25-30 in-lbs (2.8-3.4 Nm)
<b>Pneumatic Control Valve</b>	
3/8" HP Inlet Gland Nut	50 ft-lbs (68 Nm)
1/4" Outlet to Drain	25 ft-lbs (34 Nm)
Pneumatic Actuator	5 ft-lbs (7 Nm)
9/16"-1/4" HP Adapter	50 ft-lbs (68 Nm)

### Specialized Maintenance Tools

KMT Waterjet has designed tools to facilitate the removal and installation of specialized system components. These tools are illustrated in Figure 9-7, Specialized Maintenance Tools, and part numbers are provided in Table 9-3.

Figure 9-7: Specialized Maintenance Tools



**Table 9-3**  
**Specialized Maintenance Tools**  
**High Pressure Water System**

	<b>Part Number</b>
Cartridge Removal Tool	20430104
Vee Block Cradle	49830946
Plug	10078772 (9/16")
Gland Fitting	10078608 (9/16")
Seal Removal Tool	20430112
End Cap Wrench	80079247 (8x)
	80079239 (6x 8x)
Cylinder Wrench	05066139
Seal Removal Tool Stand	80078330

## 9.5 High and Low Pressure Water Piping

Before performing any maintenance on the high pressure components, it is necessary to remove the high and low pressure water piping. The following procedure should be used to remove and install the piping.



Severe injury can result if the machine is not properly locked out. Observe electrical Lockout/Tagout procedures before performing maintenance on the high pressure system components.

Ensure all pressure is relieved or blocked from the hydraulic and high pressure circuits before performing maintenance.

1. Turn the cutting water supply off.
2. Loosen and remove the high pressure gland fitting connected to the discharge high pressure check valve. Move the tubing to clear the work area.
3. Loosen and remove the low pressure piping connected to the inlet water port on the hard seal end cap.
4. When the required maintenance has been completed and the components reassembled, connect the low pressure water piping to the inlet water port on the hard seal end cap.
5. Apply Pure Goop to the threads on the high pressure gland fitting. Before installing the high pressure fitting, ensure proper collar position, 1-1/2 to 2-1/2 threads should be exposed. Install and tighten the fitting to the torque specifications in Table 9-2.
6. Turn the cutting water supply on and check for low pressure leaks.
7. Remove the cutting orifice and start the machine. Operate in low pressure mode to flush the high pressure passages.
8. Install the orifice and operate at high pressure to check for leaks.

## 9.6 High Pressure Cylinder Assembly

KMT Waterjet recommends removing the high pressure cylinder, sealing head and end cap as an assembly for servicing the plunger, high pressure seals, hydraulic piston and seal cartridge. Removing the jackbolts in the hard seal end cap is not recommended except to service the inlet check valve and cone seat on the sealing head.



## High Pressure Cylinder Assembly Removal

Prior to removing electrical power or any high or low pressure piping, start the machine from the Maintenance Screen on the control panel. The machine will start in recirculation mode, the dump valve will open and relieve the high pressure in the system.

Press the RIGHT or LEFT arrow to extend the plunger on the end to be serviced. The plunger will extend in the selected direction, allowing full exposure when the unit is disassembled.

1. Turn the machine off and observe the appropriate Lockout/Tagout procedures.



Severe injury can result if the machine is not properly locked out. Observe electrical Lockout/Tagout procedures before proceeding.

Ensure all pressure is relieved or blocked from the hydraulic and high pressure circuits before proceeding.

2. Disconnect the high and low pressure water piping, following the procedure, High and Low Pressure Water Piping.

### NOTE

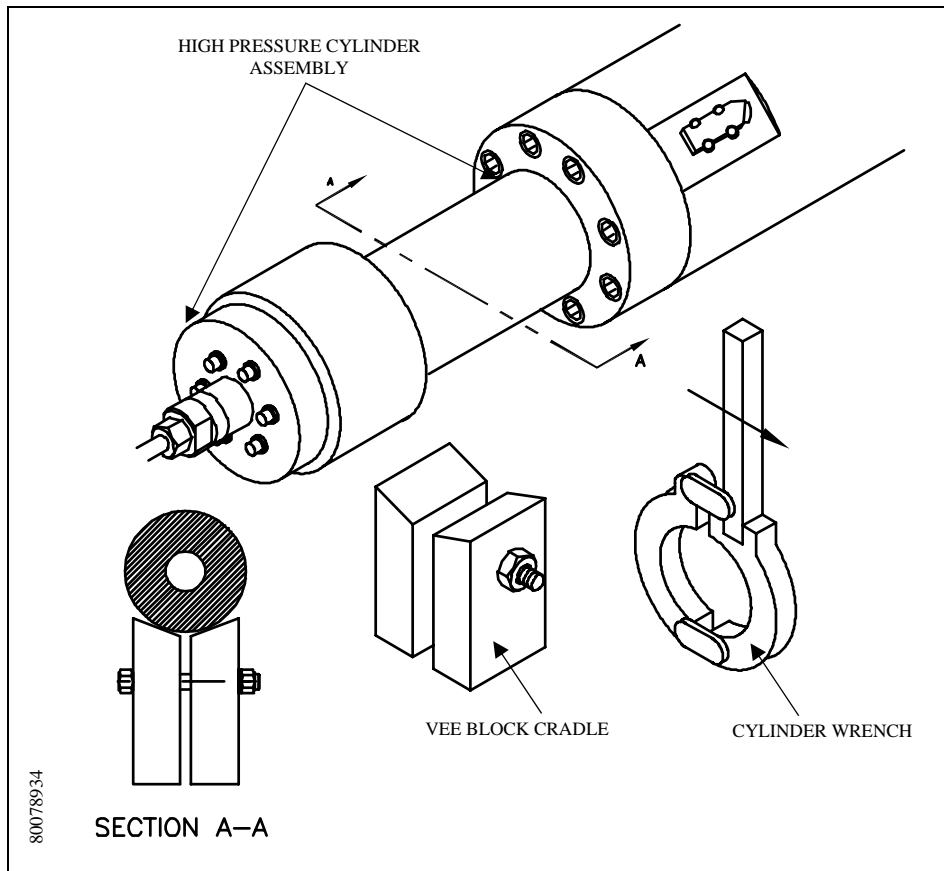
Prior to removal, verify that the alignment marks on the high pressure cylinder and on the hydraulic cylinder head are aligned. If not, check the condition of the retaining ring and the bushing retainer flange after the cylinder assembly is removed.



Due to the weight of the cylinder assembly, adequate support must be provided to prevent damage to the plunger or seals during removal and installation. See Figure 9-7, Specialized Maintenance Tools for tools available to support the high pressure assembly for this procedure.

3. Position the vee block cradle tool under the cylinder assembly. Unthread and remove the assembly from the hydraulic cylinder head and plunger. The assembly can be rotated with the cylinder wrench or by hand.

Figure 9-8: High Pressure Cylinder Assembly Removal and Installation



**NOTE**

If thread or metal surface galling is detected during removal, galled surfaces and threads must be filed, sanded and lubricated prior to reassembly. See the procedure, High Pressure Cylinder Maintenance.

**High Pressure Cylinder Assembly Installation**

1. Verify that the high pressure cylinder threads and alignment surfaces are adequately cleaned and lubricated with Pure Goop, and that the threads have been sanded and dressed if galling was encountered during removal.
2. Verify that the high pressure seal assembly, packing follower and cylinder liner are correctly installed. Align the cylinder assembly with the plunger and the hydraulic cylinder head, using the cradle tool to support the weight. Carefully push and lift the assembly into position until the threads are ready to engage.
3. Thread the cylinder assembly into the hydraulic cylinder head.



**NOTE**

If galling occurs during threading, remove the high pressure cylinder assembly and inspect the mating surfaces and threads. Repair surfaces, thoroughly clean, lubricate and thread the cylinder assembly into the hydraulic cylinder head.

**NOTE**

An alignment mark is located on the hydraulic cylinder head under the KMT logo. To ensure the high pressure cylinder is properly tightened and fully seated in the hydraulic cylinder head, it is recommended that a corresponding mark be placed on the high pressure cylinder after installation. Periodically inspect the cylinder for movement. If movement is detected, retighten the assembly.

4. Connect the high and low pressure water piping, following the procedure, High and Low Pressure Water Piping.
5. Start the machine in low pressure mode to flush air from the high pressure components and to check for obvious leaks. After 5-10 strokes, switch to high pressure operation and check for leaks.

If leaks are detected, turn the machine off and remedy the problem. When the problem has been remedied, repeat the start up procedure, moving from low to high pressure soon after the intensifier starts pumping water. There is no further need to flush air from the system.

## High Pressure Cylinder Maintenance

The plunger seal area in the high pressure cylinder bore should be inspected and cleaned each time the high pressure seal assembly is replaced.

1. Clean the sealing area on the inside diameter of the high pressure cylinder and inspect the bore for rings, scratches, pits, residue or other potential leak paths.

Seal material or residue can build up, forming a ring. Running a fingernail across the buildup will cause it to appear as a surface flaw. Grooves or ridges are typically seal debris buildup rather than marks on the inside diameter wall of the cylinder.

2. Polish the inside diameter of the cylinder where the seal will locate with 600-grit wet/dry sandpaper. Hold the sandpaper on the end of your finger and move in a cylindrical wiping motion. Polish in a circumferential motion only. Do not polish or drag the sandpaper along the length of the cylinder.
3. Clean the residue from the inside diameter of the cylinder and re-inspect for surface defects.

## 9.7 Hard Seal End Caps

KMT Waterjet recommends loosening the jackbolts and removing the hard seal end caps (HSEC) only to service the inlet check valve and the cone seat on the sealing head.

### Hard Seal End Cap Removal

Prior to removing electrical power or any high or low pressure piping, start the machine from the Maintenance Screen on the control panel. The machine will start in recirculation mode, the dump valve will open and relieve the high pressure in the system.

Press the RIGHT or LEFT arrow to retract the plunger on the opposite end to be serviced. The plunger will extend in the selected direction, allowing full exposure when the unit is disassembled.

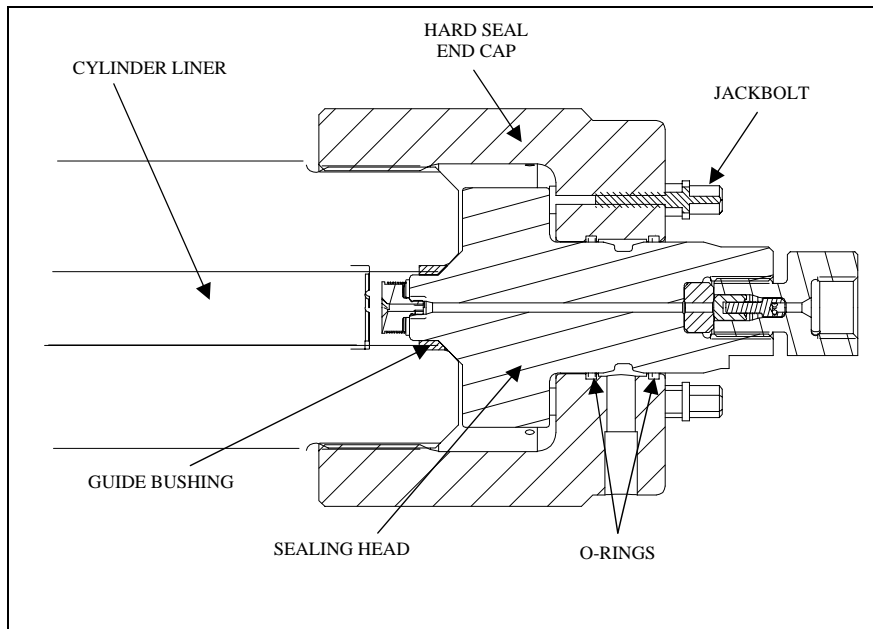
1. Turn the machine off and observe the appropriate Lockout/Tagout procedures.



Severe injury can result if the machine is not properly locked out. Observe electrical Lockout/Tagout procedures before proceeding.

Ensure all pressure is relieved or blocked from the hydraulic and high pressure circuits before proceeding.

2. Disconnect the high and low pressure water piping, following the procedure, High and Low Pressure Water Piping.
3. Loosen the jackbolts in the hard seal end cap.
4. Unscrew and remove the HSEC from the high pressure cylinder.
5. Remove the sealing head. The sealing head may be removed with the HSEC or after the end cap has been removed.
6. Verify the removal of the white plastic guide bushing used to position the sealing head relative to the high pressure cylinder. The bushing may come out with the sealing head. If not, the bushing must be removed from the cylinder bore prior to reinstalling the sealing head to avoid pushing it farther into the bore.

**Figure 9-9: Hard Seal End Cap**

### Hard Seal End Cap Installation

1. Apply FML-2 grease to the two o-rings and verify they are properly installed in the inside diameter grooves of the HSEC. Check the high pressure cylinder bore to verify the presence of the cylinder liner and to ensure the old guide bushing has been removed from the bore.
2. Apply FML-2 grease to the inside and outside diameter of the guide bushing and position the bushing on the inlet end of the sealing head.
3. Place the sealing head and the guide bushing in the end of the high pressure cylinder and press the sealing head into the cylinder by hand.
4. Apply JL-M grease to the threads on the jackbolts. Ensure the jackbolts are slightly less than flush with the inner face of the end cap.
5. Slide the end cap over the sealing head until it makes contact with the sealing head. Fully engage the threads on the end cap with the high pressure cylinder. The cone seal on the sealing head should be in contact with the cylinder.
6. Unscrew the HSEC until the inlet water port is properly oriented to facilitate the low pressure water connection. **Do not** unscrew the HSEC more than one full turn.
7. Hand-tighten the jackbolts until they make contact with the sealing head.
8. Tighten the jackbolts following the tightening sequence and torque specifications in Table 9-2.

9. Connect the high and low pressure water piping and turn the low pressure water supply on.
10. Start the machine in low pressure mode to flush air from the high pressure components and to check for obvious leaks. After 5-10 strokes, switch to high pressure operation and check for leaks.

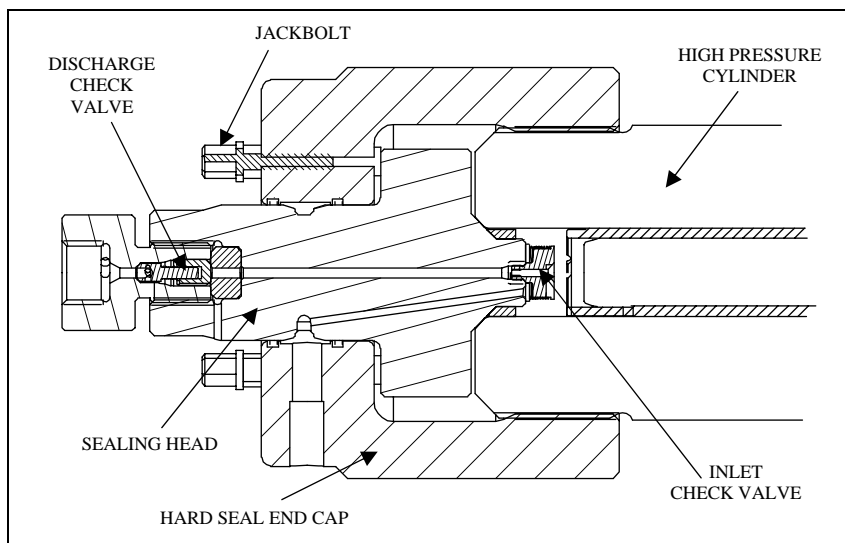
If leaks are detected, turn the machine off and remedy the problem. When the problem has been remedied, repeat the start up procedure.

## 9.8 Sealing Head

The sealing head is sealed to the outboard end of the high pressure cylinder by a 45-degree metal-to-metal compression seal. The pre-loading jackbolts in the hard seal end cap hold the sealing head against the end of the cylinder.

The inlet and discharge check valves in the sealing head ensure the low pressure and high pressure water only travels in the appropriate direction.

*Figure 9-10: Sealing Head*



### High Pressure Discharge Check Valve

The high pressure discharge check valves should be serviced on a regular, preventive maintenance schedule. The discharge check valve can be serviced with the sealing head either installed or removed from the high pressure cylinder.

1. Turn the machine off and observe the appropriate Lockout/Tagout procedures.



Severe injury can result if the machine is not properly locked out. Observe electrical Lockout/Tagout procedures before proceeding.

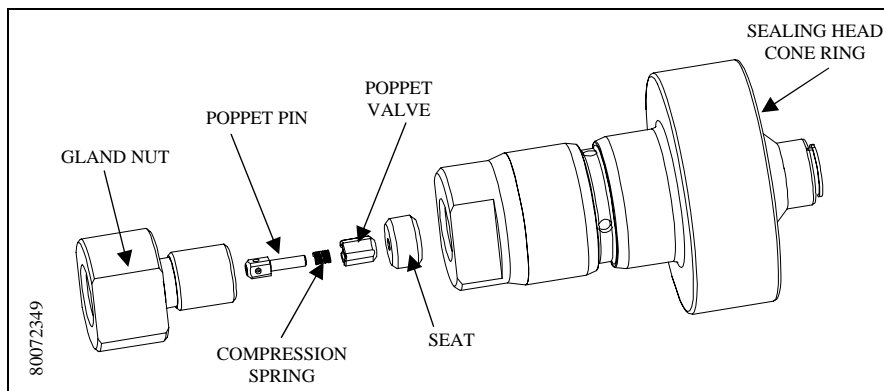
Ensure all pressure is relieved or blocked from the hydraulic and high pressure circuits before proceeding.

2. Disconnect the high pressure water piping, following the procedure, High and Low Pressure Water Piping.
3. Use two wrenches to remove the gland nut. The poppet pin, spring and poppet check valve will normally remain in the gland nut when it is removed. Remove the components from the gland nut.
4. Use a magnet to remove the seat from the sealing head.
5. Inspect the poppet pin for wear and replace the pin if worn.
6. Inspect both faces of the seat for damage or cracking. A cracked or damaged seat must be replaced. The seat can be installed with either face toward the poppet valve. If one face is worn, but the opposite is not, the seat can be reversed, placing the new surface toward the poppet valve. A slight burr at the hole edge identifies the used side of the seat. If both faces are worn, the seat must be replaced.

**NOTE**

The seat, spring and poppet valve should be replaced as a set. If one component requires replacement, replace all components.

**Figure 9-11: High Pressure Discharge Check Valve**

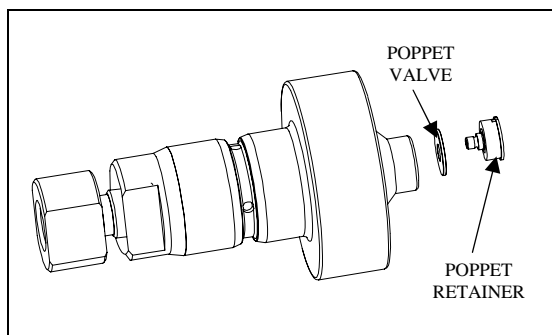


7. Apply a thin film of Pure Goop to the face of the seat opposite the poppet check valve and install the seat into the sealing head. If the existing seat is reused, install the seat with the new surface facing the poppet valve.
8. Install the poppet pin and the spring, with the larger end of the spring facing the poppet valve, and then install the poppet valve into the gland nut.
9. Apply Pure Goop to the sealing face and the threads on the gland nut and thread the gland nut into the sealing head. Hand tighten until there is a 0.20 inch (5 mm) gap between the gland nut and the sealing head. **No threads should show.** If the gap exceeds 0.20 inch (5 mm), the poppet or seat has slipped out of position. The parts must be removed, inspected and re-assembled.
10. Use a crowfoot/torque wrench combination and tighten the gland nut to the torque specifications in Table 9-2.

### Low Pressure Inlet Check Valve

The inlet check valves should be serviced on a regular, preventive maintenance schedule. The hard seal end cap must be removed to service the inlet check valve. Follow the procedure, Hard Seal End Cap Removal. When the end cap has been removed, proceed with Step 1 below.

**Figure 9-12: Low Pressure Inlet Check Valve**



1. Use a 1/2-inch flat blade screwdriver to remove the poppet retainer from the sealing head.
2. Inspect the sealing head for scratches or wear on the cone ring contact surface, and on the inlet poppet valve contact surface. If defects are detected, the surfaces must be refinished. See the procedure, Sealing Head Maintenance.
3. Inspect both faces on the inlet poppet valve. The poppet valve can be installed with either face toward the sealing head. If one face is worn, but the opposite is not, the poppet can be reversed, placing the best surface toward the sealing head. If both faces are worn, the poppet valve must be replaced.
4. Assemble the inlet poppet valve on the poppet retainer. Apply a small amount of Loctite 222 to the poppet retainer threads only. **Do not** get any Loctite on the poppet or any other surfaces on the inlet check valve.





5. Use the flat blade screwdriver to tighten the poppet retainer. Tighten the poppet retainer to the torque specifications in Table 9-2.
6. Inspect the assembled unit to ensure:
  - The poppet moves freely
  - The poppet retainer is seated against the sealing head

### **Sealing Head Maintenance**

The sealing head should be inspected for scratches, excessive sealing damage or erosion marking on the cone ring contact surface, and on the inlet poppet valve contact surface. If defects are detected, the surfaces must be refinished. The sealing head can be returned to KMT Waterjet for refinishing.

1. Clean the 45-degree surface on the cone ring with 600-grit wet/dry sandpaper, using a radial motion. It will not be possible to fully remove the main sealing marks.
2. Inspect the inlet poppet valve sealing surface for pits, scratches or jetting erosion. If necessary, refinish the surface.

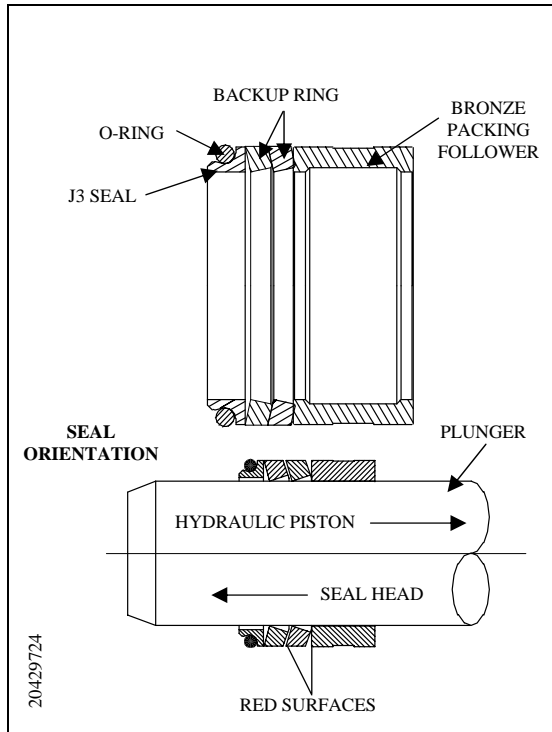
Place a piece of 1/4-1/2" thick plate glass, not window glass, on a sturdy table to provide an absolutely flat surface. Place a piece of 400-grit wet/dry sandpaper on the glass. Use even, deliberate strokes, rotating the sealing head approximately 10-15 degrees after each stroke. Polish the sealing head until it is flat and smooth. Be careful not to cause additional damage by tilting or tipping the part while polishing.

3. When the sealing head is flat and smooth, perform a final polish with 600-grit wet/dry sandpaper.

## 9.9 High Pressure Seal Assembly

The following procedure should be used to replace the high pressure seal assembly.

*Figure 9-13: High Pressure Seal Assembly*



Prior to removing electrical power or any high or low pressure piping, start the machine from the Maintenance Screen on the control panel. The machine will start in recirculation mode, the dump valve will open and relieve the high pressure in the system.

Press the RIGHT or LEFT arrow to extend the plunger on the end to be serviced. The plunger will extend in the selected direction, allowing full exposure when the unit is disassembled.

1. Turn the machine off and observe the appropriate Lockout/Tagout procedures.



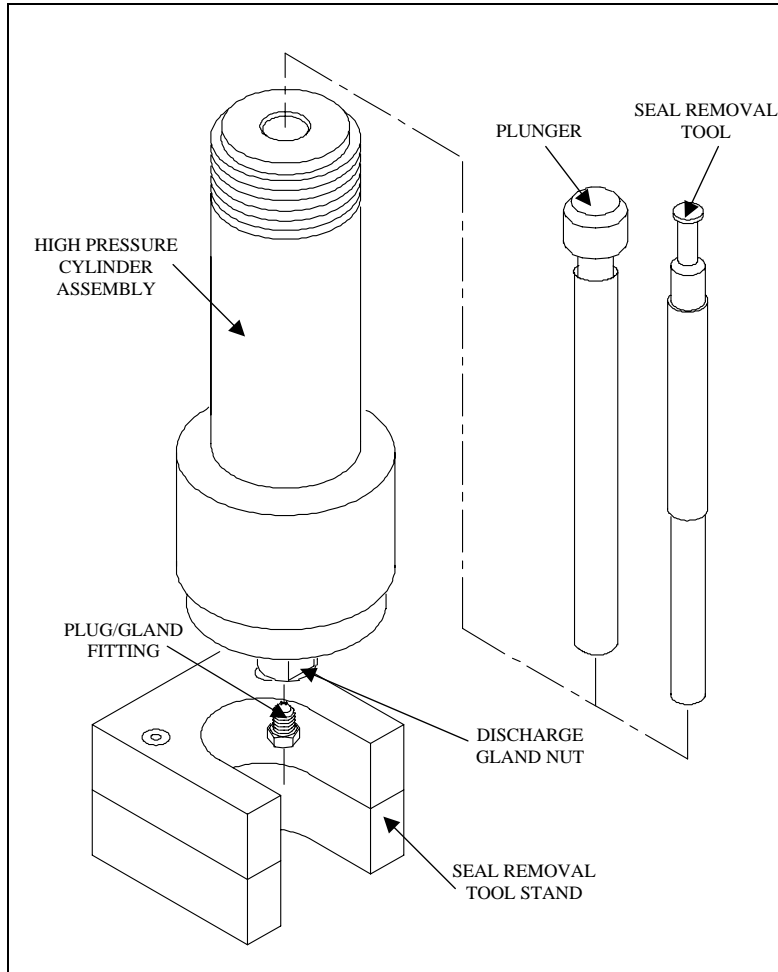
Severe injury can result if the machine is not properly locked out. Observe electrical Lockout/Tagout procedures before proceeding.

Ensure all pressure is relieved or blocked from the hydraulic and high pressure circuits before proceeding.

2. Disconnect the high and low pressure water piping, following the procedure, High and Low Pressure Water Piping.

3. Remove the high pressure cylinder assembly, following the procedure, High Pressure Cylinder Assembly Removal.

**Figure 9-14: High Pressure Seal Removal**



4. Apply Pure Goop to the threads on the high pressure plug and gland fitting. Thread the plug and gland fitting into the discharge gland nut on the sealing head and hand tighten.
5. Position the cylinder assembly upright in the seal removal tool stand. If a tool stand is not available, position the cylinder on a platform of wooden blocks with the jackbolts resting on the platform.



**Do not** stand the cylinder assembly on the top pan of the machine. The assembly is heavy and must be properly supported to prevent it from falling.

6. Fill the cylinder with water and slide the seal removal tool or a used plunger into the bronze packing follower to ensure a good seal for the removal of the seal assembly.
7. Place a shop towel around the plunger or seal removal tool to avoid splash back. Use a dead blow hammer to drive the removal tool or plunger into the cylinder until the seal components move up and out of the cylinder.
8. Remove the cylinder liner from the bore and inspect for possible heat or wear damage, or for debris. If cracks or brittleness are detected on the tabs on the ends of the liner, the liner must be replaced.
9. Feel approximately one inch into the cylinder bore for obvious ridges or grooves. If seal debris is present, follow the procedure, High Pressure Cylinder Maintenance.
10. Inspect the plunger surface for flaws. Rotate the plunger 360 degrees by hand while viewing light reflection on the surface to detect any dullness, streaks, pits or other defects. Run a fingernail perpendicular to the direction of the suspected flaws to determine the severity of defects. Depending on the seal life achieved with the removed seal assembly, make a judgment regarding plunger and/or cylinder replacement. If seal debris is present on the plunger, polish with 600-grit wet/dry sandpaper, using a radial motion.
11. Lightly coat the new seal components with FML-2 grease and install the new components on the plunger. Ensure the proper orientation of the backup rings as illustrated in Figure 9-13, High Pressure Seal Assembly.
12. Slide the cylinder liner over the plunger.
13. Install the high pressure cylinder assembly into the hydraulic cylinder head, following the procedure, High Pressure Cylinder Assembly Installation.
14. Reconnect the high and low pressure water piping and turn the low pressure water supply on.

## **9.10 Hydraulic Cartridge Seal and Plunger Removal**

The following procedure is used to remove the hydraulic cartridge seal and the plunger.

Prior to removing electrical power or any high or low pressure piping, start the machine from the Maintenance Screen on the control panel. The machine will start in recirculation mode, the dump valve will open and relieve the high pressure in the system.

Press the RIGHT or LEFT arrow to extend the plunger on the end to be serviced. The plunger will extend in the selected direction, allowing full exposure when the unit is disassembled.

1. Turn the machine off and observe the appropriate Lockout/Tagout procedures.



Severe injury can result if the machine is not properly locked out. Observe electrical Lockout/Tagout procedures before proceeding.

Ensure all pressure is relieved or blocked from the hydraulic and high pressure circuits before proceeding.

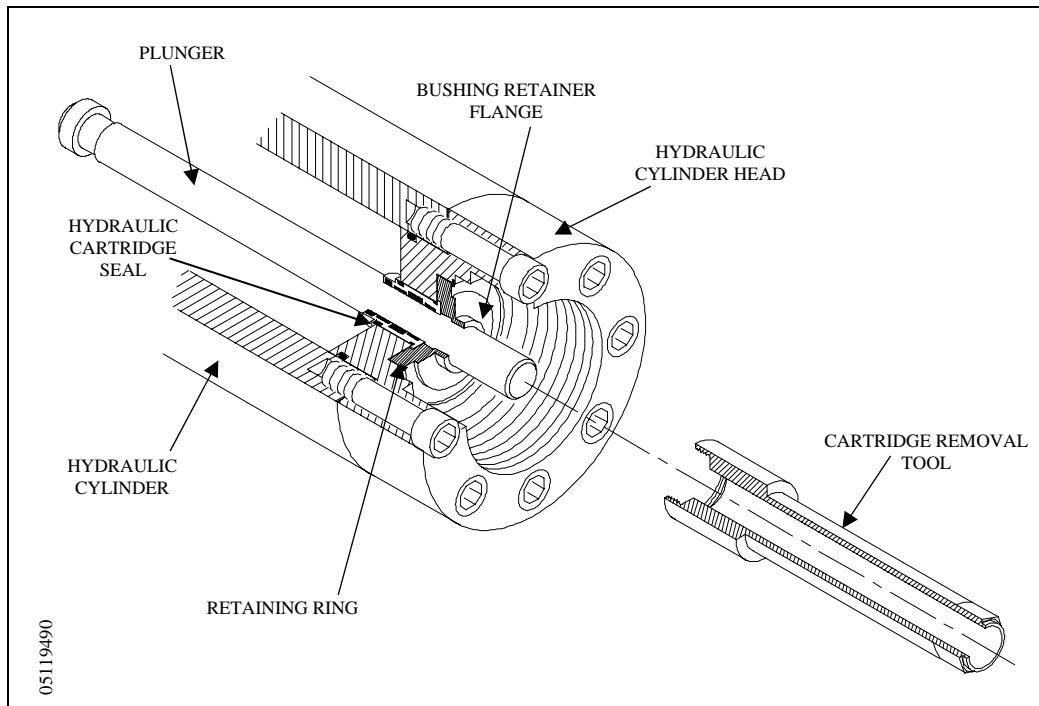
2. Disconnect the high and low pressure water piping, following the procedure, High and Low Pressure Water Piping.
3. Remove the proximity switch on the end of the hydraulic cylinder to be serviced. This will allow the hydraulic oil to drain back to the reservoir, minimizing oil spillage. It will take approximately five minutes for the oil to drain.
4. Remove the high pressure cylinder assembly, following the procedure, High Pressure Cylinder Assembly Removal.
5. Use a flat screwdriver to remove the retaining ring from the hydraulic cylinder head.
6. Remove the bushing retainer flange and clean the surfaces, weep holes and grooves. Check the retainer flange for cracks.
7. Replace the proximity switch by positioning the o-ring spacer and the switch. Apply JL-M grease to the threads on the socket head screws and tighten, following the torque specifications in Table 9-2.



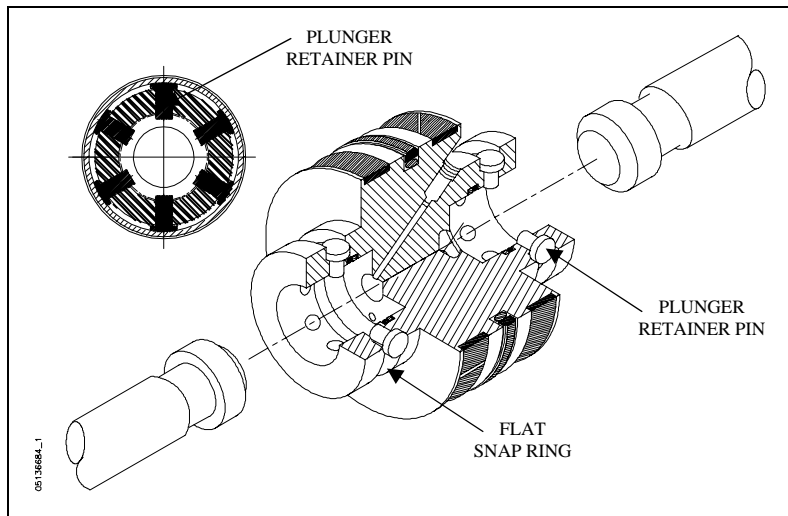
It is recommended that the proximity switch be reinstalled as soon as practical. Removal of the switch presents the potential of an oil spray hazard.

Ensure that the proximity switch is properly installed and secured prior to starting the machine. Failure to tighten the two hold down screws on each switch will result in the spray of hydraulic oil.

8. Thread the large end of the cartridge removal tool onto the hydraulic cartridge seal and pull the cartridge out, over the plunger.

**Figure 9-15: Hydraulic Cartridge Seal Removal**

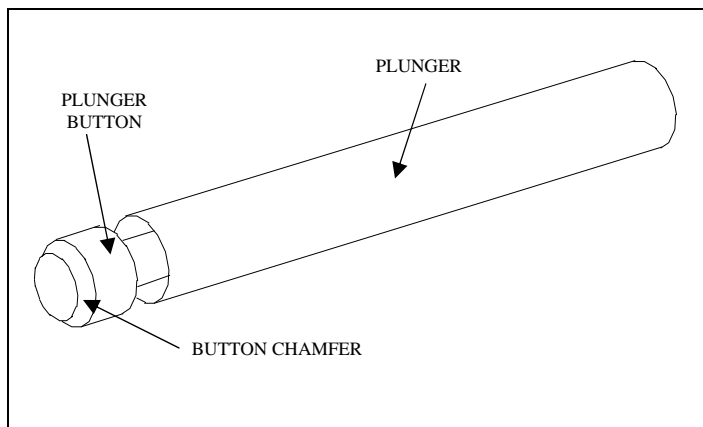
9. With the cartridge removed, the plunger can now be removed. The plunger is held in position by six retainer pins. The pins close around the plunger button to retain the plunger, and retract to release the plunger. The pins are held in position by a flat snap ring.
10. Loosen and remove the socket head screws in one of the hydraulic cylinder heads.
11. Remove the hydraulic cylinder head with the o-ring and backup ring. The mounting flat for the proximity switch provides a small lip for loosening the cylinder head.
12. Place a clean shop towel in the hydraulic port in the stem mount to prevent the retainer pins from falling into the port.
13. Remove the flat snap ring and the plunger retainer pins. Pull the plunger out of the piston.

**Figure 9-16: Plunger Retainer Pins**

### Plunger Maintenance

Plunger surfaces can become streaked with longitudinal scratches or flaws, and discolored or dull in appearance. If any of these conditions become severe, the high pressure seal assembly and possibly the hydraulic cartridge seal will leak.

Accumulation of debris on the surface of the plunger can be removed by polishing in a radial direction with 600-grit sandpaper. However, plunger surface flaws usually cannot be repaired on site. The plunger can be returned to KMT Waterjet for reconditioning.

**Figure 9-17: Plunger**

### Plunger Installation

Use the following procedure to install the plunger.

1. Push the plunger into the piston.

2. Place a small amount of FML-2 grease on the retainer pins to prevent them from falling out and install the pins.
3. Replace the snap ring and remove the shop towel from the hydraulic port.



Make sure the towel has been removed from the hydraulic port before proceeding.

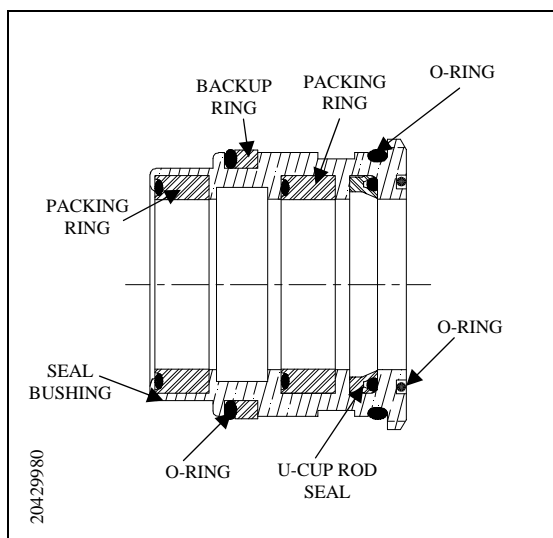
4. Verify that the o-ring and backup ring are properly positioned in the groove on the hydraulic cylinder head, and that they are sufficiently lubricated with FML-2 grease.
5. Position the cylinder head in the end of the hydraulic cylinder. Apply JL-M grease to the threads on the socket head screws. Install the screws in the cylinder head and tighten, following the torque specifications in Table 9-2.

### Hydraulic Cartridge Seal

Seals in the hydraulic cartridge can be removed and replaced, or the complete cartridge can be replaced. Seal components differ slightly, depending on the plunger diameter. See Figure 9-18, Hydraulic Cartridge Seal.

Use caution during the removal and installation of the seal components to avoid scratching the surface of the cartridge. The seal removal tool, a plastic or wooden dowel, or similar object can be used for seal removal. **Do not** use screwdrivers, wires or other metal objects that could damage the cartridge. To avoid damaging the new seals, the seal installation tool can be used for installation.

Figure 9-18: Hydraulic Cartridge Seal





1. Carefully remove the worn seals and o-rings from the cartridge by pushing them with a plastic or wooden dowel, or similar object. Remove the seals closest to the open ends first, and work toward the center.
2. Inspect the seals for unusual wear, deformation or cuts. Note any unusual buildup of solid material or debris creating possible leak paths.
3. Inspect the surface of the cartridge body for scratches, deformation, signs of metal-to-metal contact or other unusual wear. Carefully examine the surface of the grooves on the inside diameter. Note any scratches in the axial direction that could create a leak path.
4. Apply FML-2 grease to the inside and outside diameter of the cartridge body, and to the individual seal components.
5. Install the seals, starting in the center and working toward the ends. See Figure 9-18 for the proper orientation of the u-cup seals. If available, use the seal installation tool to install the u-cup seals. See Figure 9-24, Pneumatic Valve Seal Tools.
6. Verify that the u-cup o-rings are properly positioned after installation.
7. When the seal components are properly installed, apply FML-2 grease to the exposed surfaces of the seals and slide the hydraulic cartridge seal over the plunger, into the cavity of the hydraulic cylinder head.
8. Thoroughly clean the bushing retainer flange, including the cross-drilled weep holes. Install the retainer flange over the plunger.
9. Install the retaining ring, ensuring the retaining ring fully seats inside the groove in the hydraulic cylinder head.

The o-rings on the hydraulic cartridge will take up clearance. Tap lightly on the bushing retainer flange with the cartridge removal tool to compress the o-rings enough to start the retaining ring in the groove. Use a flat blade screwdriver to push on the outer edge of the retainer flange while working one end of the retaining ring into the groove. The retainer flange should tilt or tip enough to allow the retaining ring to move into the groove. Continue working the ring into the groove while tilting the retainer flange until the ring is fully seated.

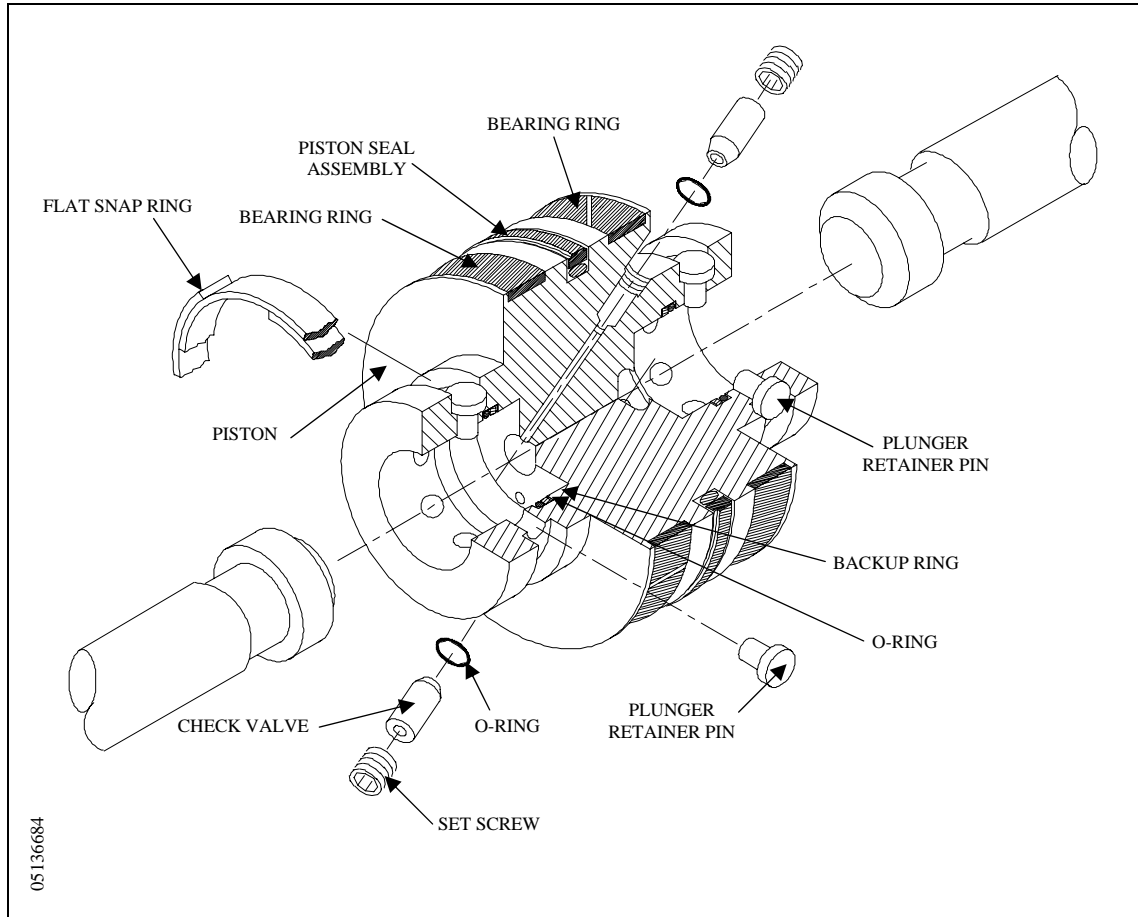
10. Install the high pressure cylinder assembly into the hydraulic cylinder head, following the procedure, High Pressure Cylinder Assembly Installation.
11. Connect the high and low pressure water piping and turn the low pressure water supply on.

## **9.11 Hydraulic Piston**

Two bearing rings provide wear contact between the piston and the inside diameter of the hydraulic cylinder. On each end of the piston, six retainer pins hold the plunger in position. The plunger retainer pins are held in place by a flat snap ring. Two internal check valves vent

unwanted hydraulic pressure from one side of the piston to the other, preventing pressure from building behind the plunger button.

**Figure 9-19: Hydraulic Piston Components**



## Hydraulic Piston Removal

The following procedure is used to remove the hydraulic piston.

1. Turn the machine off and observe the appropriate Lockout/Tagout procedures.

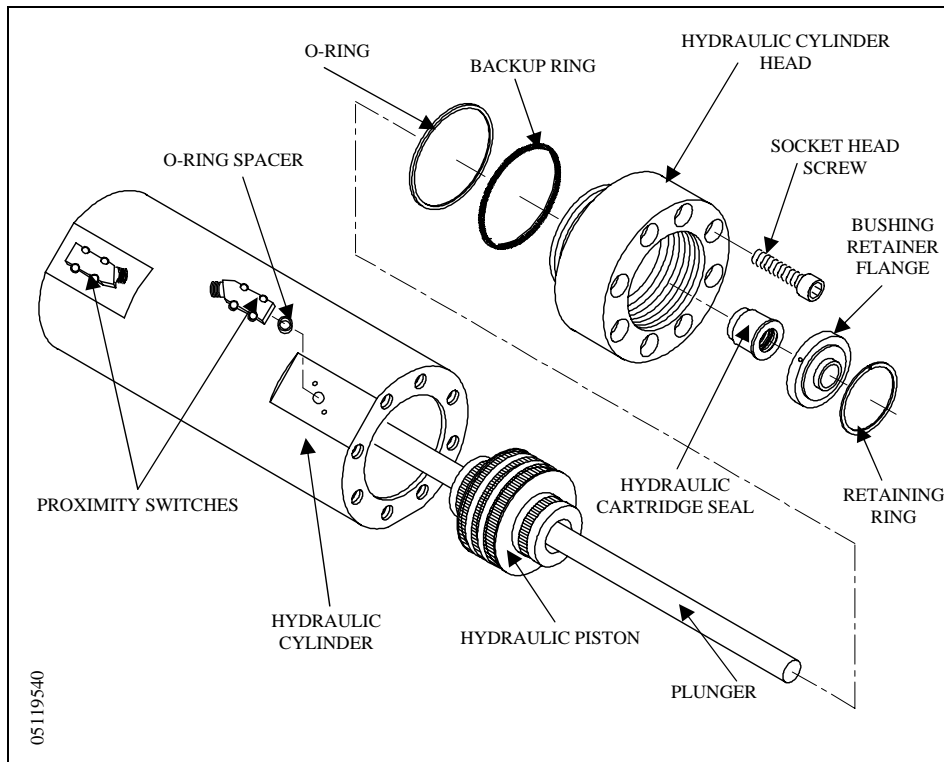


Severe injury can result if the machine is not properly locked out. Observe electrical Lockout/Tagout procedures before proceeding.

Ensure all pressure is relieved or blocked from the hydraulic and high pressure circuits before proceeding.

2. Disconnect the high and low pressure water piping from both ends of the intensifier, following the procedure, High and Low Pressure Water Piping.
3. Remove the high pressure cylinder assembly on each end of the intensifier, following the procedure, High Pressure Cylinder Assembly Removal.

**Figure 9-20: Hydraulic Piston Removal**



4. Remove both of the proximity switches to prevent interference and to allow the hydraulic oil to drain back to the reservoir, minimizing oil spillage. It will take approximately five minutes for the oil to drain.
5. Remove the retaining ring, bushing retainer flange and the hydraulic cartridge seal from both hydraulic cylinder heads. It is not necessary to remove the plunger.
6. Loosen and remove the socket head screws in one of the hydraulic cylinder heads.
7. Remove the hydraulic cylinder head with the o-ring and backup ring. The mounting flat for the proximity switch provides a small lip for loosening the cylinder head.
8. Grasp the plunger firmly and pull the piston out of the hydraulic cylinder.

### Bearing Rings and Seal Assembly

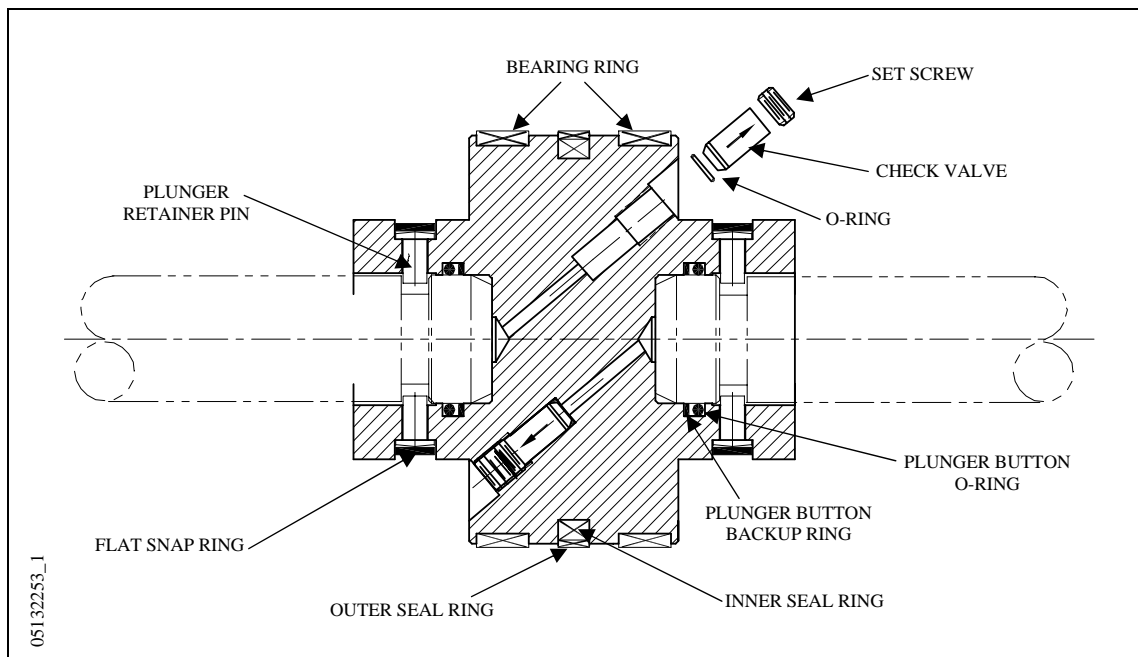
1. Remove the plungers.
2. Use a smooth, dull-edged blade made from brass or similar soft metal material to remove the two bearing rings and the seal assembly.

**NOTE**

**Do not** scratch the surfaces of the piston seal groove. Scratches on the sides or bottom of the groove can result in hydraulic leaks.

3. Inspect the bottom of the seal grooves for marks, scratches and residue buildup. Clean and/or repair the groove surfaces as required.
4. Apply FML-2 grease to the new bearing rings and install the rings.
5. The piston seal assembly consists of an inner and an outer seal ring. Apply FML-2 grease to both rings. Use the smooth, dull-edged blade to install the inner ring, ensuring the ring is not twisted after installation. Slide the outer seal ring over the metal edges and ease it into position over the inner ring.

**Figure 9-21: Hydraulic Piston**



### Plunger Button Sockets, Seals and Retainer Pins

1. Remove the flat snap rings and plunger retainer pins on both ends of the piston.
2. Inspect the snap rings and the pins for unusual wear or deformation. Clean and inspect the pin holes for unusual wear, deformation or hole enlargement.
3. Remove the plunger button o-ring and backup ring from each plunger socket. Take care not to scratch or damage the seal groove surfaces.
4. Clean and inspect the seal grooves for residue buildup or surface marks that could cause seal leaks.
5. Inspect the plunger button sockets for unusual wear.

#### NOTE

Due to the high contact force between the piston and the plunger, the plunger may make an impression in the bottom of the socket. This compression mark or indentation is normal.

6. Apply FML-2 grease to new plunger button backup rings and o-rings. Install the rings in the internal groove in the plunger socket. If the backup ring is not installed the plunger can be forced out of the plunger socket.
7. Install the plungers and the retainer pins, verifying that each pin moves freely without excess side play in the pin holes.
8. Install the flat snap ring over the pins.

### Internal Check Valves

It is not necessary to service the internal check valves unless a problem is suspected. If the check valves or the internal passages in the piston require service, plunger button, seal and pin servicing is also recommended. See Figure 9-21, Hydraulic Piston.

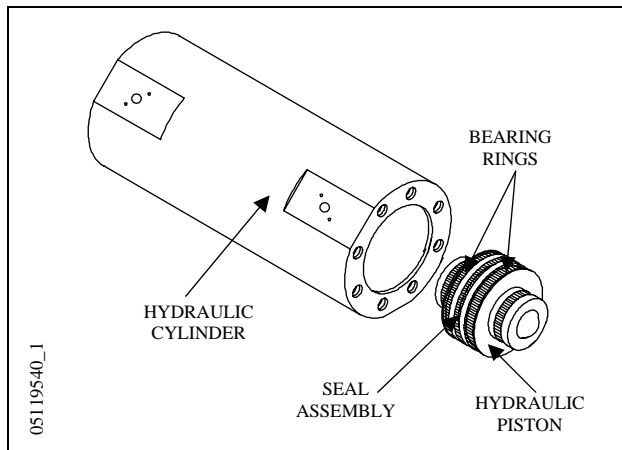
1. Loosen the set screw and remove the check valves and o-rings. Clean the internal passages.
2. Apply FML-2 grease to a new o-ring and install the new o-ring in the check valve passage. Use a blunt, pencil-like instrument to position it in the bottom of the passage.
3. Clean and install a new check valve with the chamfered end toward the o-ring.
4. Sparingly apply Loctite, threadlocker adhesive to the set screw. Thread the screw over the check valve cartridge and tighten.

**NOTE**

Excess threadlocker adhesive can clog the check valve or block the internal passage. To avoid excess adhesive, position the set screw on an allen wrench and apply the adhesive. Hold the screw horizontal on a paper towel and rotate the screw to remove excess adhesive.

**Hydraulic Piston Installation**

1. Ensure that the hydraulic cylinder bore is free of grit or contamination.
2. Install the plungers.
3. Lubricate the bearing rings and seal assembly, and lightly lubricate 2-3 inches of the cylinder bore with FML-2 grease.

**Figure 9-22: Hydraulic Piston Installation**

4. Install the piston into the hydraulic cylinder bore. If necessary, use a plastic head hammer to drive the piston into position between the holes for the proximity switches.
5. Verify that the o-ring and backup ring are properly positioned in the groove on both hydraulic cylinder heads, and that they are sufficiently lubricated with FML-2 grease.
6. Position the cylinder heads in the ends of the hydraulic cylinder. Apply JL-M grease to the threads on the socket head screws. Install the screws in each hydraulic cylinder head and tighten, following the torque specifications in Table 9-2.
7. Replace the hydraulic cartridge seal, bushing retainer flange and retaining ring in both hydraulic cylinder heads.
8. Replace the proximity switches by positioning the o-ring spacers and the switches. Apply JL-M grease to the threads on the socket head screws and tighten, following the torque specifications in Table 9-2.



Ensure that the proximity switches are properly installed and secured prior to starting the motor. Failure to tighten the two hold down screws on each switch will result in the spray of hydraulic oil.

9. Install the high pressure cylinder assemblies into the hydraulic cylinder heads, following the procedure, High Pressure Cylinder Assembly Installation.
10. Connect the high and low pressure water piping. And turn the low pressure water supply on.

## **9.12 Hydraulic Cylinder Maintenance**

The inside diameter surface of the hydraulic cylinder should be inspected for wear grooves and surface finish whenever the hydraulic cylinder heads are removed. Excessive grooving is indicative of piston seal wear.

## **9.13 High Pressure Attenuator**

The high pressure attenuator is not serviceable at the customer level. KMT Waterjet Systems tests the seals in the attenuator at pressures exceeding normal operating pressure, making disassembly difficult. If the attenuator develops a high pressure water leak, it should be replaced.

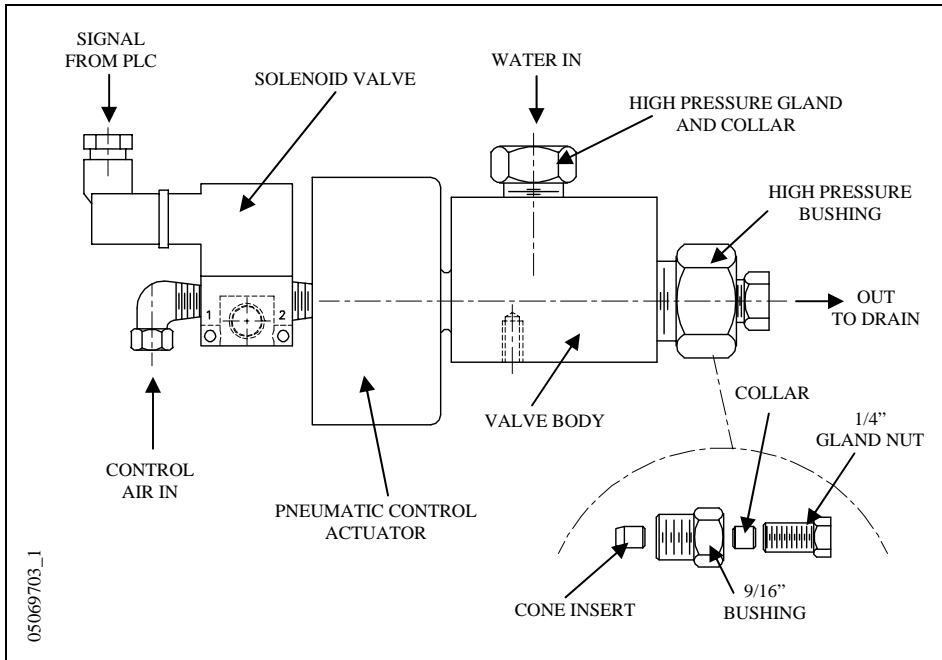
### 9.14 High Pressure Dump Valve

The high pressure dump valve assembly includes a normally open high pressure water valve and a solenoid operated air valve. The following procedure is recommended for servicing the high pressure dump valve. Failure to follow this procedure will cause damage to the stem, valve seat, or both.



The high pressure dump valve is a safety device designed to instantly release high pressure from the system. **Proper maintenance is imperative** to prevent potential personal injury.

Figure 9-23: High Pressure Dump Valve

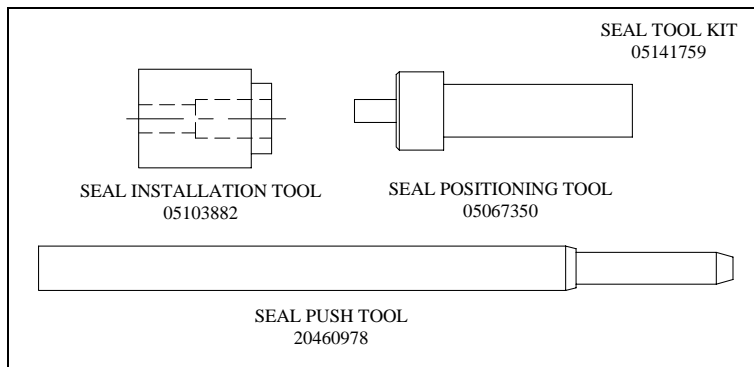


05069703\_1



Figure 9-24, Pneumatic Valve Seal Tools, illustrates the special seal tools recommended for this procedure.

**Figure 9-24: Pneumatic Valve Seal Tools**



### **Pneumatic Control Valve**

For reliable operation, it is recommended that the valve seat, seal assembly, brass backup ring and stem always be replaced at the same time. The SST backup ring can be reused.

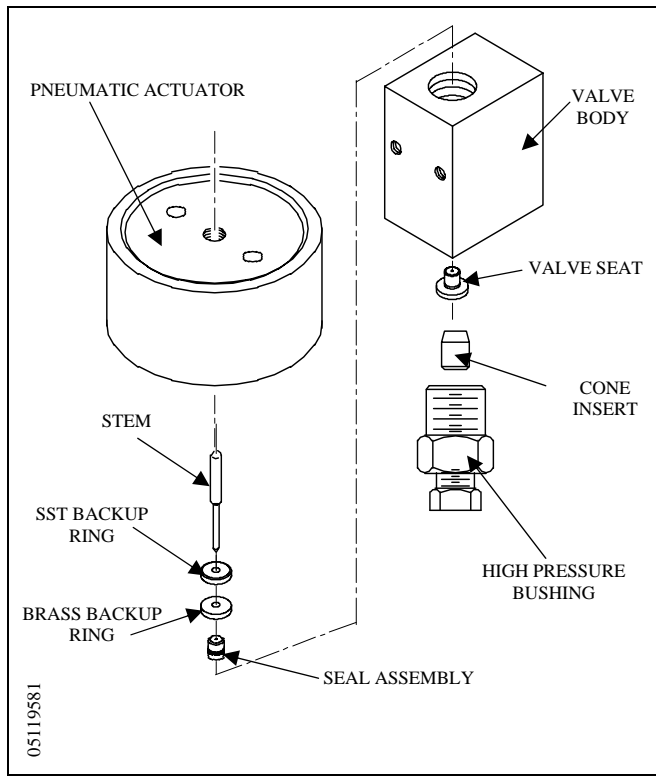


Severe injury can result if the machine is not properly locked out. Observe electrical Lockout/Tagout procedures before proceeding.

Ensure all pressure is relieved or blocked from the hydraulic and high pressure circuits before proceeding.

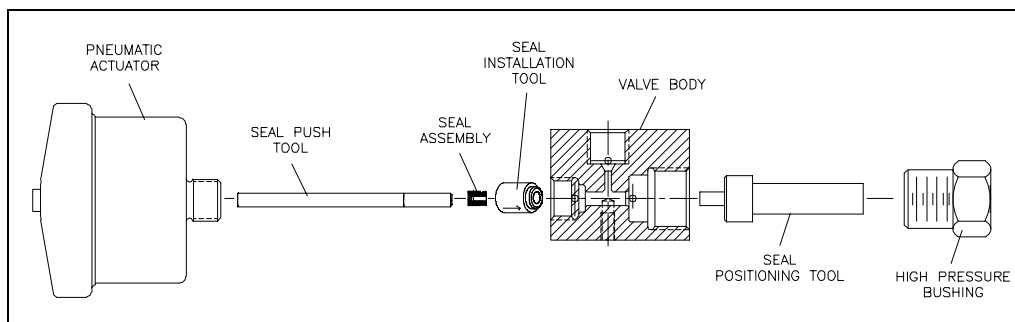
1. Turn the air supply off.
2. Remove the air supply hose, and the electrical connection to the solenoid valve.
3. Loosen and remove the high pressure gland connection and the drain connection.
4. Remove the valve and actuator assembly from the machine.

Figure 9-25: Pneumatic Control Valve Components



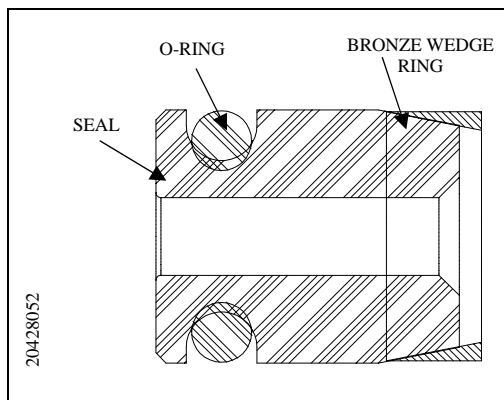
5. Loosen the cylinder head on the actuator. Unscrew and remove the actuator from the valve body.
6. Unscrew the high pressure adapter and remove the adapter, adapter cone and valve seat.
7. Remove the stem, SST backup ring and brass backup ring from the valve body.
8. Remove the seal assembly by pushing it with a dowel rod made of wood, plastic or brass. The seal push tool can also be used to remove the seal assembly. The assembly must be pushed out through the actuator port in the top of the valve body.
9. Clean and inspect the valve body, being careful not to damage or scratch the bore.

Figure 9-26: Valve Seal Installation



- To replace the seal assembly, first remove the bronze wedge ring. Lubricate the new seal and o-ring with FML-2 food grade grease. Insert the seal and o-ring into the seal installation tool, inserting the o-ring end of the seal first so the tapered end of the seal faces the actuator. The arrow on the installation tool indicates the direction the tool is inserted in the valve body and the direction the seal is inserted in the tool.

**Figure 9-27: Seal Assembly**



- Place the seal positioning tool into the opposite end of the valve body. Thread the high pressure bushing into the valve body until light contact is made with the positioning tool.
- With the seal in position, place the seal installation tool into the mating cavity of the valve body. Use the seal push tool to push the seal into the bore of the valve body until the shoulder of the push tool contacts the seal installation tool.
- Remove the push tool and the installation tool from the valve body.
- Place the bronze wedge ring, thick end first, onto the seal push tool and use it as a guide to position the wedge ring onto the seal. Remove the push tool and ease the wedge ring lightly onto the seal with the tip of your finger.
- Install the existing SST backup ring and a new brass backup ring on a new stem. The vee groove on the SST backup ring must face toward the brass backup ring. The small OD of the brass backup ring must face toward the seal assembly. See Figure 9-25, Pneumatic Control Valve Components.
- Apply FML-2 grease to the tip of stem and insert the stem with the backup rings into the top of the valve body so the stem enters the ID of the seal assembly.
- Apply Pure Goop anti-seize compound to the threads of the actuator and carefully thread it into the valve body, guiding the stem head into the hole in the actuator. Turn the actuator clockwise until resistance is felt. Reverse the actuator 1/4 turn, and give it a quick spin clockwise to seat it. **Hand-tighten only, 5 ft-lbs (7 Nm).**
- Remove the high pressure bushing and the seal positioning tool.
- Apply Pure Goop anti-seize compound to all surfaces, except the ID, of a new valve seat. Install the seat into the opposite end of the valve body, inserting the small OD first.

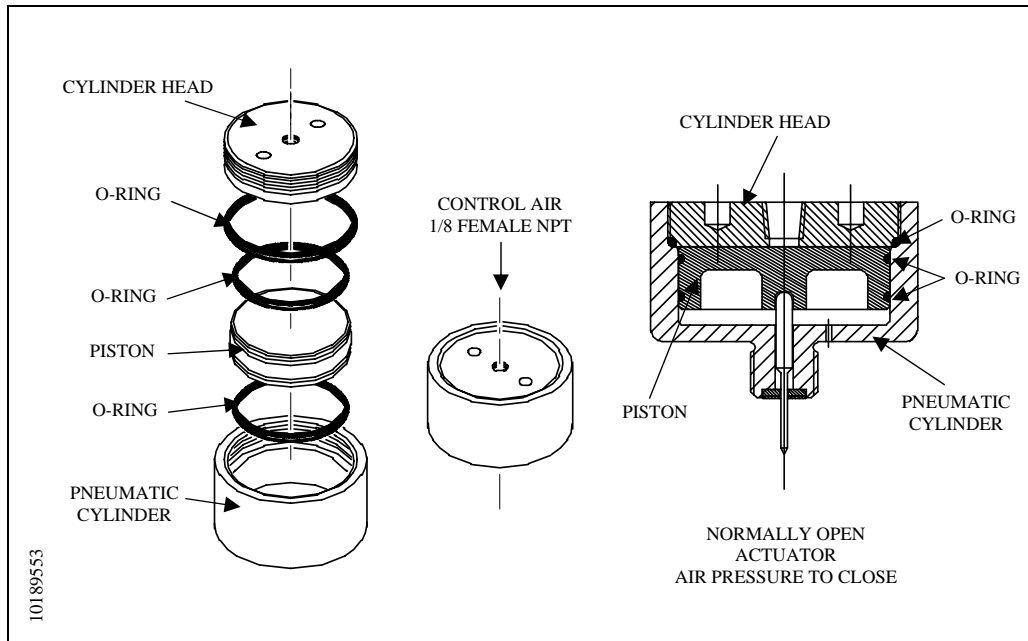


20. Apply anti-seize compound to the threads on the high pressure adapter, and on the back side of the adapter cone. Position the adapter cone in the adapter, install the adapter and torque to 50 ft-lbs (68 Nm).
21. Replace the 1/4-inch drain gland nut and collar and torque to 25 ft-lbs (34 Nm).
22. Apply anti-seize compound to the threads on the 3/8-inch high pressure gland fitting. Install the collar and the gland fitting and torque to 50 ft-lbs (68 Nm).
23. Install the air supply hose and the electrical connection to the solenoid valve. Turn the air pressure to the actuator on and test the valve for leaks and proper operation.

## Pneumatic Actuator

The following procedure is used to service the pneumatic actuator.

Figure 9-28: Pneumatic Actuator



1. Unscrew and remove the cylinder head using a strap wrench and a pin spanner. Remove the piston from the cylinder.



Do not install the pneumatic cylinder in a vise to remove the cylinder head. This may distort the body and seize the piston, preventing proper operation.

2. Remove the o-ring on the cylinder head. Apply FML-2 grease to a new o-ring and install.
3. Remove the two o-rings on the piston. Apply FML-2 grease to two new o-rings and install.
4. Install the piston in the pneumatic cylinder. Apply anti-seize compound to the threads on the cylinder head and screw it into the pneumatic cylinder.

## 9.15 Weep Holes

High pressure seals and connections fail gradually and begin leaking slowly. Weep holes are located at every threaded high pressure connection to provide a vent for internal leaks. Water or oil dripping from a weep hole indicates one or more internal components are beginning to fail.

Table 9-4 lists the location of the weep hole, the possible source of the leak and the corrective action required.

**Table 9-4**  
**Weep Holes**  
**High Pressure Water System**

<b>Location</b>	<b>Indication</b>	<b>Comments</b>
<i>Hydraulic Cylinder Head</i>		
Hydraulic oil leaking from the weep hole in the hydraulic cylinder head	Failed hydraulic cartridge seal	Replace the cartridge seal. If the leak persists, check the plunger for linear scratches or scoring.
Water leaking from the weep hole on the hydraulic cylinder head flange	Failed high pressure seal assembly	Replace the high pressure seal assembly.
	Damaged plunger	Check the plunger for longitudinal scratches or flaws. If detected, replace the plunger or return to KMT for evaluation.
	Seal material buildup on plunger	Polish the plunger surface following the procedure, Plunger Maintenance.
	Damaged high pressure cylinder	Check for scratches, grooves or material buildup on the inside diameter of the cylinder. If detected, polish the bore following the procedure, High Pressure Cylinder Maintenance.
		Check the inside diameter of the cylinder for expansion where the high pressure seal assembly is located. If detected, replace the cylinder.



**Table 9-4  
Weep Holes  
High Pressure Water System**

Location	Indication	Comments
<i>Sealing Head</i>		
Water leaking from the weep hole in the sealing head	Seat in the discharge check valve is not sealing properly	Make sure the gland nut is tightened to the proper torque specification.  Inspect the seat, sealing head and gland nut for cracks.
	Internal crack in sealing head	Replace the sealing head.  <i>A cracked sealing head can result in water leaking from the high pressure outlet passage to the low pressure inlet passages.</i>  <i>The sealing head body can become extremely hot.</i>
	Improper torque on gland nut	Tighten the gland nut to the proper torque specification.
	Erosion or scratches on the contact surface of the sealing head, or on the gland nut where the seat makes contact	Polish the surfaces following the procedure, Sealing Head Maintenance.
	High pressure piping gland nut is not tight and is not sealing properly	Tighten the gland nut to the proper torque specification.
Water leaking from the weep hole in the gland nut	Improper high pressure piping connection	Check the number of exposed threads past the collar on the high pressure piping. Only 1-1/2 to 2-1/2 threads should be exposed.
		Check high pressure piping for damage, cracks or deformation.
		Inspect the gland nut for deformation of the threads.
	Damaged sealing head gland nut	Check the gland nut for cracks due to fatigue. If cracks are detected, replace the gland nut.



**Table 9-4**  
**Weep Holes**  
**High Pressure Water System**

<b>Location</b>	<b>Indication</b>	<b>Comments</b>
<b><i>Hard Seal End Cap</i></b>		
Water leaking from the weep holes in the hard seal end cap	Damaged high pressure cylinder	Check for scratches or grooves on the 45-degree cone seal surface. If detected, polish to remove following the procedure, Sealing Head Maintenance.
	External crack in sealing head	Replace the sealing head.
	Damaged sealing head	Check for scratches or grooves on the 45-degree surface of the sealing head. If detected, polish the surface following the procedure, Sealing Head Maintenance.
	Improper torque on jackbolts	Re-torque the jackbolts to the proper torque specification.





## SECTION 10

### TROUBLESHOOTING

#### 10.1 Overview

The troubleshooting guide will help identify the probable cause of a system malfunction and assist in providing corrective action. The following symptoms are discussed in this section:

1. High boosted water temperature
2. Outlet booster pump pressure is falling below 30 psi (2 bar)
3. Inlet water flow is poor and the filter housing is not filling completely
4. Water is leaking around the bleed valve on the filter head
5. High oil temperature resulting in shutdown
6. Low oil level resulting in shutdown
7. Restricted or no cooling flow
8. Hydraulic pressure but no high pressure water pressure
9. No hydraulic oil pressure
10. Pump shaft will not turn
11. Pump will not start
12. Console display and lights do not illuminate
13. Pump quits running
14. No control power
15. Red light on operator's console is flashing
16. Abnormal fluctuations in high pressure water signal
17. Hot surfaces on the high pressure cylinder components
18. Low cutting water supply pressure
19. Low cutting water pressure
20. Hydraulic oil leaking from the weep hole in the hydraulic cylinder head
21. Water leaking from the weep hole on the hydraulic cylinder head flange
22. Water leaking from the weep hole in the sealing head
23. Water leaking from the weep hole in the sealing head gland nut
24. Water leaking from the weep holes in the hard seal end cap



## 10.2 Troubleshooting Guide

Listen to the machine and observe it in operation. Learn to recognize the normal sounds and operating conditions of the system. Carefully define the symptom of the problem. Locate the symptom on the troubleshooting guide that most closely corresponds to the problem.

If the symptoms in the guide do not correspond to the malfunction, or if the problem is not resolved by the recommended corrective action, contact the KMT Customer Service Department for assistance.

**SL-V Series Troubleshooting Guide**

Malfunction		Indication	Comments
1.	High boosted water temperature	Orifice is blocked with debris	
		Long deadhead condition	
		Insufficient water supply	
		Booster pump temperature switch malfunction	
2.	Outlet booster pump pressure is falling below 30 psi (2 bar)	Inlet water pressure is low	
		Filter element is dirty and needs to be replaced	
		Booster pump needs to be adjusted, or replaced	
3.	Inlet water flow is poor and the filter housing is not filling completely	Pipe sizing for inlet cutting water should be checked for pressure and flow	Cutting water supply will be lacking capacity or flow.
4.	Water is leaking around the bleed valve on the filter head	O-ring that closes the passage has deteriorated	A small o-ring under the valve can deteriorate causing the passage to remain open. The o-ring can be replaced by removing the screw and spring on the underneath side.



**SL-V Series Troubleshooting Guide**

	<b>Malfunction</b>	<b>Indication</b>	<b>Comments</b>
5.	High oil temperature resulting in shutdown	Cooling water flow is restricted	Check cooling water source for proper temperature and flow rate.
		Water modulating valve is stuck open or closed	Replace the valve.
		Scale build up in the heat exchanger has restricted the flow	The heat exchanger will need to be flushed or replaced.
6.	Low oil level resulting in shutdown		Check the level gauge
			Check for hydraulic leaks
			Check the level switch.
7.	Restricted or no cooling flow	Check cooling water flow to and from the heat exchanger	The water pressure differential across the heat exchanger requires a minimum of 35 psi (2.4 bar) for flow through the exchanger.
		Water modulating valve is stuck or out of adjustment	Replace the valve.
			Adjust the valve.

**SL-V Series Troubleshooting Guide**

	<b>Malfunction</b>	<b>Indication</b>	<b>Comments</b>
<b>8.</b>	Hydraulic pressure but no high pressure water pressure	Proximity switch failure	From the Maintenance Screen on the control panel, jog the intensifier left and right and verify that the red light comes on at both proximity switches.
		I/O relay failure	From the Maintenance Screen on the control panel, jog the intensifier left and right and verify that the green light comes on at both directional valve solenoids.
		Coil failure on the directional control valve	Check the coils on the directional valve with a volt meter to verify if they are good or bad.
		PLC failure	If there are inputs from the proximity switches, but no outputs, contact the KMT Customer Service Department for a logic review and verification of PLC failure.
<b>9.</b>	No hydraulic oil pressure	The high and low limit compensators on the hydraulic pump are blocked with debris and are not controlling the swashplate	Disassemble the compensators, clean and inspect the components following the maintenance procedure in Section 7, Hydraulic System.
		Incorrect motor rotation	Check the motor rotation.
<b>10.</b>	Pump shaft will not turn	The flexible coupling has failed	Replace the flexible coupling.
		The hydraulic pump has seized	Replace the hydraulic pump.

**SL-V Series Troubleshooting Guide**

	<b>Malfunction</b>	<b>Indication</b>	<b>Comments</b>
<b>11.</b>	Pump will not start	Emergency stop button is depressed	Pull the E-STOP button out.
			Check all remote E-STOP buttons.
		Main power is disconnected	Check the main power and verify that the main power disconnect is on.
		Control power has been interrupted	Check the power supply circuit for a tripped breaker.
			Check the input and output of the 24 volt DC power supply.
			Check the 2K1 relay.
		A protection fault has been activated	Check the display panel for fault messages.
Motor overload relay has been tripped	Identify the source of the overload and remedy the problem. Reset the overload relay.		
Inlet water valve is turned off	Press the RESET button on the Run Screen to reset the water valve.		
<b>12.</b>	Console display and lights do not illuminate	Emergency stop button is depressed	Pull the E-STOP button out.
			Check all remote E-STOP buttons.
		Main power is disconnected	Check the main power and verify that the main power disconnect is on.
		Control power is not available	Check the power supply circuit for a tripped breaker.
			Check the input and output of the 24 volt DC power supply.
			Check the 2K1 relay.

**SL-V Series Troubleshooting Guide**

	<b>Malfunction</b>	<b>Indication</b>	<b>Comments</b>
<b>13.</b>	Pump quits running	Unsafe operation has been detected	Check the display panel for fault messages.
		Electrical power has been interrupted	Check the power supply circuit for a tripped breaker.
			Check the input and output of the 24 volt DC power supply.
			Verify that power is available at the main power source.
			Check the 2K1 relay coil.
		Check the 4K0 relay.	
Motor overload relay has been tripped	Identify the source of the overload and remedy the problem. Reset the overload relay.		
<b>14.</b>	No control power	Circuit breaker has been tripped	Check the input and output of all circuit breakers.
		Power supply fault	Check the input and output voltages at the power supply.
		Emergency stop button is depressed	Pull the E-STOP button out.
			Check all remote E-STOP buttons.
		Master control relay is not energized	Verify that the contactor coil is pulling in on the master control relay.
Contact set failure on the master control relay	Verify that the contact sets on the master control relay are changing states when the relay is energized.		



SL-V Series Troubleshooting Guide

	Malfunction	Indication	Comments
15.	Red light on operator's console is flashing	An alarm condition has occurred	<p>Check the display panel for fault messages.</p> <p><i>Refer to Section 4, Operation, for additional information regarding warning and alarm conditions and recovery procedures.</i></p>
16.	Abnormal fluctuations in high pressure water signal	Large, worn or damaged orifice	Make sure the orifice does not exceed the capacity of the pump.
			Make sure the orifice is in good working condition. Verify that the jewel is installed in the orifice mount.
		Check valve leakage	Inspect the discharge check valves in the sealing heads.
			Inspect the inlet check valves in the sealing heads.
		Seal leakage	Inspect the high pressure seal on the plunger.
			Inspect the sealing head-to-cylinder sealing surfaces.
		Hydraulic control malfunction	Check the operation of the hydraulic relief valve.
Verify that the directional control valve is shifting properly.			
Check the operation of the proximity switches.			

**SL-V Series Troubleshooting Guide**

	<b>Malfunction</b>	<b>Indication</b>	<b>Comments</b>
<b>17.</b>	Hot surfaces on the high pressure cylinder components	Leaking discharge check valve	Inspect the condition of the seat, poppet valve, spring, poppet pin and sealing head surface on the discharge end of the sealing heads.
		Leaking inlet check valve	Inspect the condition of the poppet valve, poppet retainer and the spring, if applicable, on the inlet end of the sealing heads.
		Damaged sealing head	Check the cone flange surface of the sealing head for scratches or mechanical damage and replace if necessary.
		Damaged high pressure cylinder	Check the high pressure cylinder for cracks.
<b>18.</b>	Low cutting water supply pressure	Restricted water supply	Check cutting water supply flow and pressure.
		Clogged water filter	Check the condition of the low pressure water filter and replace the filter element if necessary.
		Trapped air	Bleed the air from the cutting water plumbing.
<b>19.</b>	Low cutting water pressure	Low hydraulic pressure setting	If operating in low pressure, switch to high pressure operation and check the hydraulic pressure setting.  <i>Not applicable when the machine is equipped with the optional proportional pressure control.</i>
			Clean the high pressure adjustment valve.
			Clean the compensators on the hydraulic pump.
		Collapsed element in the high pressure line filter	Check the element in the high pressure line filter.





SL-V Series Troubleshooting Guide

	Malfunction	Indication	Comments
20.	Hydraulic oil leaking from the weep hole in the hydraulic cylinder head	Failed hydraulic cartridge seal	Replace the cartridge seal. If the leak persists, check the plunger for linear scratches or scoring.
21.	Water leaking from the weep hole on the hydraulic cylinder head flange	Failed high pressure seal assembly	Replace the high pressure seal assembly.
		Damaged plunger	Check the plunger for longitudinal scratches or flaws. If detected, replace the plunger or return to KMT Waterjet for evaluation and rework.
		Seal material buildup on plunger	Polish the plunger surface following the procedure, Plunger Maintenance, detailed in Section 9, High Pressure Water System.
		Damaged high pressure cylinder	Check for scratches, grooves or material buildup on the inside diameter of the cylinder. If detected, polish the bore following the procedure, High Pressure Cylinder Maintenance, detailed in Section 9, High Pressure Water System.
			Check the inside diameter of the cylinder for expansion where the high pressure seal assembly is located. If detected, replace the cylinder.



SL-V Series Troubleshooting Guide

	Malfunction	Indication	Comments
22.	Water leaking from the weep hole in the sealing head	Seat in the discharge check valve is not sealing properly	Make sure the gland nut is tightened to the proper torque specification.
			Inspect the seat, sealing head and gland nut for scratches, erosion or cracks.
		Improper torque on gland nut	Tighten the gland nut to the proper torque specification.
		Erosion or scratches on the contact surface of the sealing head, or on the gland nut where the seat makes contact	Polish the surfaces following the procedure, Sealing Head Maintenance, detailed in Section 9, High Pressure Water System.
23.	Water leaking from the weep hole in the sealing head gland nut	High pressure piping gland nut is not tight and is not sealing properly	Tighten the gland nut to the proper torque specification.
		Improper high pressure piping connection	Check the number of exposed threads past the collar on the high pressure piping. Only 1-1/2 to 2-1/2 threads should be exposed.
			Check high pressure piping for damage, cracks or deformation.
			Inspect the gland nut for deformation of the threads.
Damaged sealing head gland nut	Check the gland nut for cracks due to fatigue. If cracks are detected, replace the gland nut.		



SL-V Series Troubleshooting Guide

	Malfunction	Indication	Comments
24.	Water leaking from the weep holes in the hard seal end cap	Damaged high pressure cylinder	Check for scratches or grooves on the 45-degree sealing surface of the sealing head. If detected, polish to remove following the procedure, Sealing Head Maintenance, detailed in Section 9, High Pressure Water System.
			Replace the high pressure cylinder.
		External crack in sealing head	Replace the sealing head.
		Damaged sealing head	Check for scratches or grooves on the 45-degree surface of the sealing head. If detected, polish the surface following the procedure, Sealing Head Maintenance, detailed in Section 9, High Pressure Water System.
		Improper torque on jackbolts	Re-torque the jackbolts to the proper torque specification.



## SECTION 11

### SPECIFICATIONS

#### 11.1 Overview

Comprehensive listings of specifications for the SL-V SRP 100 intensifier are provided in this section.

**Table 11-1**  
**SL-V SRP 100**

Model	Motor Horsepower Rating	
	HP	Kw
SL-V SRP 100	100	75

#### 11.2 Installation Specifications

##### Environment

Installation location	Indoors
Air borne dust/contaminants	Minimal
Ambient temperature	
Minimum storage	36° F (2° C)
Minimum operating	40° F (5° C)
Maximum operating	104° F (40° C)
Maximum relative humidity* (at maximum operating temperature)	95%

**\*Note:** When the relative humidity is above 50%, the oil in the reservoir should be checked frequently for water content.

##### Sound Level

Sound level with optional side panels	77.5 [dB(A)]
---------------------------------------	--------------



### Equipment Dimensions and Weights

	Length	Width	Height	Weight
SL-V SRP 100	77.75" (1,975 mm)	36.00" (914 mm)	57.19" (1,453 mm)	4,200 lbs (1,905 kg)

### Service Connections

Contaminated Waste Drain	1/2" NPT Connection
Cutting Water Out	9/16" HP Connection
Plant Air In	1/4" NPT Connection
Cooling Water In	1/2" NPT Connection
Cooling Water Out	1/2" NPT Connection
Cutting Water In	1/2" NPT Connection
Drain	1/2" NPT Connection

## 11.3 Water Specifications

### Cutting Water Supply (Low Pressure Water System)

Minimum consumption	11.0 gpm (41.6 L/min)
Minimum inlet water pressure	35 psi (2.4 bar) flowing
Maximum inlet water pressure	80 psi (5.5 bar)
Maximum booster outlet water pressure	120 psi (8.3 bar)
Booster pump factory set inlet pressure	58 psi (4 bar)
Booster pump factory set outlet pressure	120 psi (8.3 bar)
Optimum inlet water temperature	65° F (18° C)
Maximum inlet water temperature	85° F (29° C)
Low inlet water pressure switch setting	30 psi (2 bar)
Low booster pressure switch setting	30 psi (2 bar)
Booster pump temperature switch setting	128° F (53° C)

**Cooling Water Supply (Recirculation System)**

---

Reservoir capacity	48 gal (182 L)
Low oil level shutdown	37 gal (140 L)
Maximum consumption at 75° F (24° C)	5.5 gpm (20.8) L/min
Total heat rejection	17.7 HP (13.2 kW)
Minimum operating oil temperature	60° F (15° C)
Optimum operating oil temperature	110-115° F (43-46° C)
Hot oil shutdown (maximum operating oil temperature)	144° F (62° C)
Minimum inlet cooling water pressure	35 psi (2.4 bar)
Maximum inlet cooling water pressure	100 psi (6.9 bar)
Oil filtration rating (Beta filtration rating)	$\beta_{10} \geq 100^*$
Fluid cleanliness rating (ISO fluid cleanliness rating))	17/14**
Nominal recirculation pressure	30 psi (2 bar)

**Recommended oil type**

General service	Mobil #DTE Heavy Medium, No. 021029  Conoco Hydroclear™ multi-purpose R&O
Food service	Anderol PQ AA-20 Food Grade Oil

---

\* **Note:** For each particle per milliliter downstream of the filter greater than 10 microns, there are 100 particles per milliliter larger than 10 microns upstream of the filter.

\*\***Note:** Indicates ISO 4406 range numbers for maximum permissible number of particles per milliliter, greater than 5 and 15 microns.

17	<1,300 particles per milliliter, >5 microns
14	<160 particles per milliliter, >15 microns

---

**Water Quality Standards**

The quality of the inlet cutting water supply is one of the most important factors affecting component life and performance. Water treatment requirements can be determined by a water analysis.

The cutting water supply must meet the following standards. A high concentration of dissolved solids, especially calcium, silica and chlorides will affect high pressure component life.



**Table 11-2**  
**Water Quality Standards**

<b>Constituent (mg/l)</b>	<b>Minimum Requirement</b>	<b>Better</b>	<b>Best</b>
Alkalinity	50	25	10
Calcium	25	5	0.5
Carbon Dioxide	0	0	0
Chloride	100	15	1
Free Chlorine	1	1	0.05
Iron	0.2	0.1	0.01
Magnesium as Mg	0.5	0.1	0.1
Manganese as Mn	0.1	0.1	0.1
Nitrate	25	25	10
Oxygen	2	1	0.1
Silica	15	10	1
Sodium	50	10	1
Sulfate	25	25	1
TDS*	200	100	5**
Total Hardness	25	10	1
pH	6.5-8.5	6.5-8.5	6.5-8.5
Turbidity (NTU)	5	5	1

\* **Note:** Total dissolved solids  
\*\***Note:** Do not reduce the TDS beyond this amount or the water will be too aggressive.

**Table 11-3**  
**Water Impurities**

Constituent	Chemical Formula	Comments
Alkalinity	Bicarbonate (HCO <sub>3</sub> ) Carbonate (CO <sub>3</sub> ) Hydrate (OH), expressed as CaCO <sub>3</sub>	Acid neutralizing capacity of water. Foaming and carryover of solids, causes embrittlement of steel, can produce CO <sub>2</sub> , a source of corrosion.
Calcium	Ca	When dissolved makes water hard; contributes to the formation of scale.
Carbon Dioxide	CO <sub>2</sub>	Causes corrosion
Chloride	Cl	Adds to solid content and increases corrosive character of water; in relative percentage presence with oxygen induces stress corrosion cracking.
Free Chlorine	Cl <sub>2</sub>	Oxidizing agent; can attack elastomeric seals and damage reverse osmosis (RO) membranes.
Iron	Fe <sup>++</sup> (ferrous) Fe <sup>+++</sup> (ferric)	Discolors water or precipitation; source of scale and erosion.
Magnesium as Mg		When dissolved makes water hard; contributes to the formation of scale.
Manganese as Mn	Mn <sup>++</sup>	Discolors water or precipitation; source of scale and erosion.
Nitrate	NO <sub>3</sub>	Adds to solid content; effect is not generally significant industrially.
Oxygen	O <sub>2</sub>	Causes corrosion
Silica	SiO <sub>2</sub>	Causes scale
Sodium	Na	Found naturally; introduced to water in the ion exchange water softening process.
Sulfate	SO <sub>4</sub>	Adds to solid content; combines with calcium to form calcium sulfate scale.
TDS		Measure of the total amount of dissolved matter in water.
Total Hardness	CaCO <sub>3</sub>	Sum of all hardness constituents in water; typically expressed as their equivalent concentration of calcium carbonate; primarily due to calcium and magnesium in solution, but may include small amounts of metal. Carbonate hardness is usually due to magnesium and calcium bicarbonate; non-carbonate hardness is due to sulfates and chlorides.
pH		Intensity of the acidic or alkaline solids in water; pH scale runs from 0, highly acidic, to 14, highly alkaline; with 7 being neutral.





## 11.4 Electrical Specifications

### Electrical System

Motor type	TEFC (Totally Enclosed Fan Cooled)
Controls	
Voltage	24 volts DC
Power supply	20 amps DC

### Ampacity and Power Voltage Requirements

Power Voltage	Motor Horsepower	Full Load Amps	Circuit Breaker Amps
200/3/50	100	248	350
200/3/60	100	236	350
208/3/50	100	242	350
208/3/60	100	231	350
230/3/60	100	218	300
380/3/60	100	130	175
400/3/50	100	124	175
415/3/50	100	121	175
460/3/50	100	114	175
480/3/60	100	106	175
575/3/60	100	91	125

## 11.5 Hydraulic and High Pressure Water System Specifications

### Hydraulic System

Maximum operating pressure	2,815 psi (194 bar)
Main system relief valve	3,400 psi (235 bar)



### High Pressure Water System

---

Plunger diameter	1.50" (38.1 mm)
Piston diameter	5.50" (139.7 mm)
Intensification ratio	12.4:1
Maximum flow rate	
35,000 psi (2,413 bar)	2.8 gpm (10.6 L/min)
Minimum outlet pressure	5,000 psi (345 bar)
Maximum outlet pressure	35,000 psi (2,413 bar)

### Pneumatic Control Valve

Maximum water pressure	60,000 psi (4,137 bar)
Minimum air pressure	85 psi (5.9 bar)
Maximum air pressure	100 psi (6.9 bar)
Maximum air flow rate	1.0 cfm (0.028) m <sup>3</sup> /min

---

### Orifice Capacity

The following tables provide flow data for some of the more popular orifices.

**Table 1-1**  
**SL-V SRP 100**

Motor Horsepower Rating		Maximum Operating Pressure	Maximum Single Orifice Diameter ( <i>at full pressure</i> )
HP	Kw		
100	75	35,000 psi (2,413 bar)	0.026 inch (0.66 mm)



**Table 11-5  
Flow (GPM)**

<b>Orifice Size inches (mm)</b>	<b>30,000 psi (2,068 bar)</b>	<b>35,000 psi (2,413 bar)</b>
0.003 (0.076)	0.03	0.04
0.004 (0.102)	0.06	0.06
0.005 (0.127)	0.09	0.10
0.006 (0.152)	0.13	0.14
0.007 (0.178)	0.18	0.20
0.008 (0.203)	0.24	0.26
0.009 (0.229)	0.30	0.32
0.010 (0.254)	0.37	0.40
0.011 (0.279)	0.45	0.48
0.012 (0.305)	0.53	0.57
0.013 (0.330)	0.62	0.67
0.014 (0.356)	0.72	0.78
0.015 (0.381)	0.83	0.90
0.016 (0.406)	0.94	1.02
0.017 (0.432)	1.07	1.15

The flow requirements for operating multiple orifices are determined by adding the requirements in Table 11-5 for each orifice. Examples are shown below.

<b>Orifice Size inches (mm)</b>	<b>Number of Orifices</b>	<b>Operating Pressure</b>	<b>Calculation</b>	<b>Total Flow</b>
0.008 (0.203)	3	35,000	3 x .26	.78
0.012 (0.305) 0.009 (0.229)	1 1	30,000	.53 + .30	.83

Note that the SRP 100 pump is limited to 2.8 gpm (10.6 L/min).

### Torque Specifications

Measurements are made with lubricated components and a certified calibrated torque wrench. Inconsistencies in wrench settings, lubrication and technique may not produce a leak free seal. If leakage occurs, the torque can be increased to seal the components. However, **do not exceed the recommended torque value by more than 15 percent**. If leakage persists, there is a component problem.

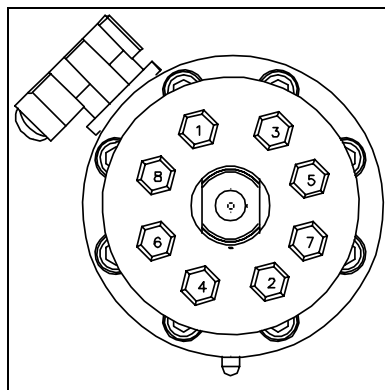


Excessive torque can cause component damage or failure, resulting in potential hazards to equipment and personnel.

### Torque Specifications

<b>Hard Seal End Cap</b>	
Jackbolts	8 (7/16") each
1st Stage	Hand Tight
2nd Stage	20 ft-lbs (27 Nm) Crossing Pattern*
3rd Stage	32-35 ft-lbs (43-47 Nm) Crossing Pattern
4th Stage	32-35 ft-lbs (43-47 Nm) Clockwise Pattern From Bolt 1
Socket Wrench Size	3/8 inch

**8-Bolt Crossing Pattern**



\* **Note:** A maximum torque of 38 ft-lbs (51 Nm) is etched on the hard seal end cap. This represents the **maximum** allowable torque, not the recommended torque.



## Torque Specifications

<b>Hydraulic Cylinder Head</b>	
Socket Head Screws	6 (3/4") each
Torque	170-175 ft-lbs (230-237 Nm)
Hex Key	5/8 inch
<b>Proximity Switch</b>	
Socket Head Screws	2 (1/4") each
Torque	140-160 in-lbs (16-18 Nm)
Hex Key	3/16 inch
<b>Stem Mount</b>	
Socket Head Screws	4 (3/8") each
Torque	35-40 ft-lbs (47-54 Nm)
Hex Key	5/16 inch
<b>Sealing Head</b>	
Discharge Gland Nut	200 ft-lbs (271 Nm)
Poppet Retainer	25-30 in-lbs (2.8-3.4 Nm)
<b>Pneumatic Control Valve</b>	
3/8-inch HP Inlet Gland Nut	50 ft-lbs (68 Nm)
1/4-inch Outlet to Drain	25 ft-lbs (34 Nm)
Pneumatic Actuator	5 ft-lbs (7 Nm)
9/16"-1/4" HP Adapter	50 ft-lbs (68 Nm)
<b>High Pressure Fittings</b>	
1/4-inch Gland Nut	25 ft-lb (34 Nm)
3/8-inch Gland Nut	50 ft-lb (68 Nm)
9/16-inch Gland Nut	110 ft-lb (149 Nm)



## SECTION 12 PARTS LIST

### 12.1 Overview

This section contains a comprehensive list of all standard and optional parts for the SL-V SRP 100 intensifier unit. To facilitate the ordering of replacement parts, item numbers in each table correspond to the identifying numbers in the accompanying figures.

Use the following information to contact the Spare Parts Department at KMT Waterjet Systems.

#### USA

Customer Service Department  
KMT Waterjet Systems  
PO Box 231  
635 West 12th Street  
Baxter Springs, KS 66713-0231  
USA

Phone (800) 826-9274  
Fax (620) 856-2242  
Email [wj.service@kmtgroup.com](mailto:wj.service@kmtgroup.com)  
[wj.parts@kmtgroup.com](mailto:wj.parts@kmtgroup.com)

#### Europe

Spare Parts Manager  
KMT Waterjet Systems GmbH  
Wasserstrahl Schneidetechnik  
Auf der Laukert 11  
D-61231 Bad Nauheim  
Germany

Phone +49-6032-997-119  
Fax +49-6032-997-271  
Email [order.spares@kmt-waterjet.com](mailto:order.spares@kmt-waterjet.com)



## 12.2 Part Nomenclature

The following list explains the abbreviations and numerical sizes used in the following part descriptions.

### Abbreviations and Nominal Size Guide

Item	Description
1/4, 9/16, 3/4	Nominal sizes in fractions of an inch
D	Degree
HP or LP	High pressure or low pressure
ID or OD	Inside diameter or outside diameter
JIC	37-degree flared, threaded hydraulic fitting
NO or NC	Normally open or normally closed
NPT	National Pipe Thread, pipe thread and pressure vessel standard
psi or ksi	Pounds per square inch or thousands of pounds per square inch
SAE O-Ring	O-ring threaded port style, Society of Automotive Engineers (SAE) standard
TUV	German pressure vessel code and inspection agency



### 12.3 Index

Part lists are arranged in the following sequence:

#### Parts List Index

Table	Description	Part Number	Page	Table	Description	Part Number	Page
12-1	SRP 100 Intensifier Unit		12-4	12-16	Electrical Assembly, 200-208/50-60	20427087	12-33
12-2	Intensifier Assembly	20429675	12-6	12-17	Electrical Assembly, 230/50-60	20434686	12-35
12-3	Hydraulic Cartridge Seal	20429980	12-8	12-18	Electrical Assembly, 380-415/50-60	20424282	12-37
12-4	Sealing Head Assembly	20429698	12-9	12-19	Controls Subassembly, 200-208, 230/50-60	20415406	12-39
12-5	Pneumatic Valve/Actuator Assembly	10184760	12-10	12-20	Controls Subassembly, 380-415/50-60	80077845	12-42
12-6	Hydraulic Piston Assembly	05146576	12-12	12-21	Control Panel Configuration, 200-208/50-60	20413542	12-45
12-7	High Pressure Piping	20432786	12-14	12-22	Control Panel Configuration, 230/50-60	20434678	12-47
12-8	Low Pressure Water Filter Assembly	80087976	12-16	12-23	Control Panel Configuration, 380-415/50-60	20434274	12-49
12-9	Hydraulic Power Package	20435207 / 20428358	12-18	12-24	Proportional Pressure Control	80075732	12-51
12-10	Motor/Pump Assembly	20428316 / 80076458	12-20	12-25	High Pressure Transducer	20431959	12-53
12-11	Hydraulic Manifold Assembly	49835796	12-22				
12-12	Hydraulic Hose Connections	05142351	12-24				
12-13	Reservoir Assembly	05104153	12-26				
12-14	Bulkhead Pipe Assembly	20436131	12-28				
12-15	Cover Assembly	80074768	12-31				

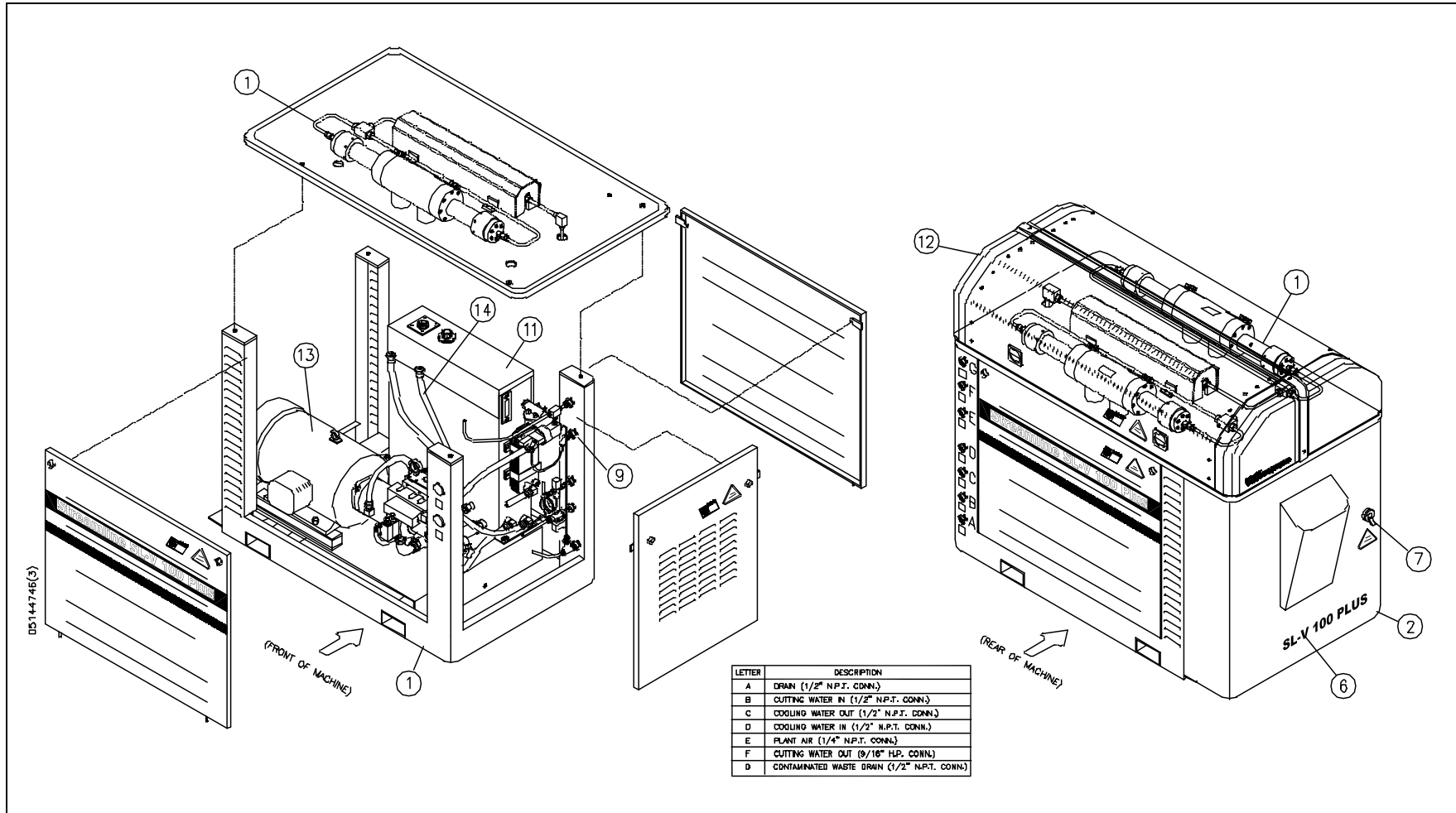




**Table 12-1**  
**SL-V SRP 100 Intensifier Unit**

<b>Item</b>	<b>Part Number</b>	<b>Description</b>	<b>Quantity</b>
1	20432786	High Pressure Piping Assembly	1
2	20427087	Electrical Assembly, 200-208/50-60	1
	20434686	Electrical Assembly, 230/50-60	
	20424282	Electrical Assembly, 380-415/50-60	
6	20461182	Decal Package	1
7	05128087	Startup Tag	1
9	20436131	Bulkhead Pipe Assembly	1
10	05141569	Frame Assembly	1
11	05104153	Reservoir Assembly	1
12	80074768	Cover Assembly	1
13	20435207	Hydraulic Power Package, 230, 380-415/50-60	1
	20428358	Hydraulic Power Package, 200-208/50-60	
14	05142351	Hydraulic Hose Connections	1

Figure 12-1: SL-V SRP 100 Intensifier Unit

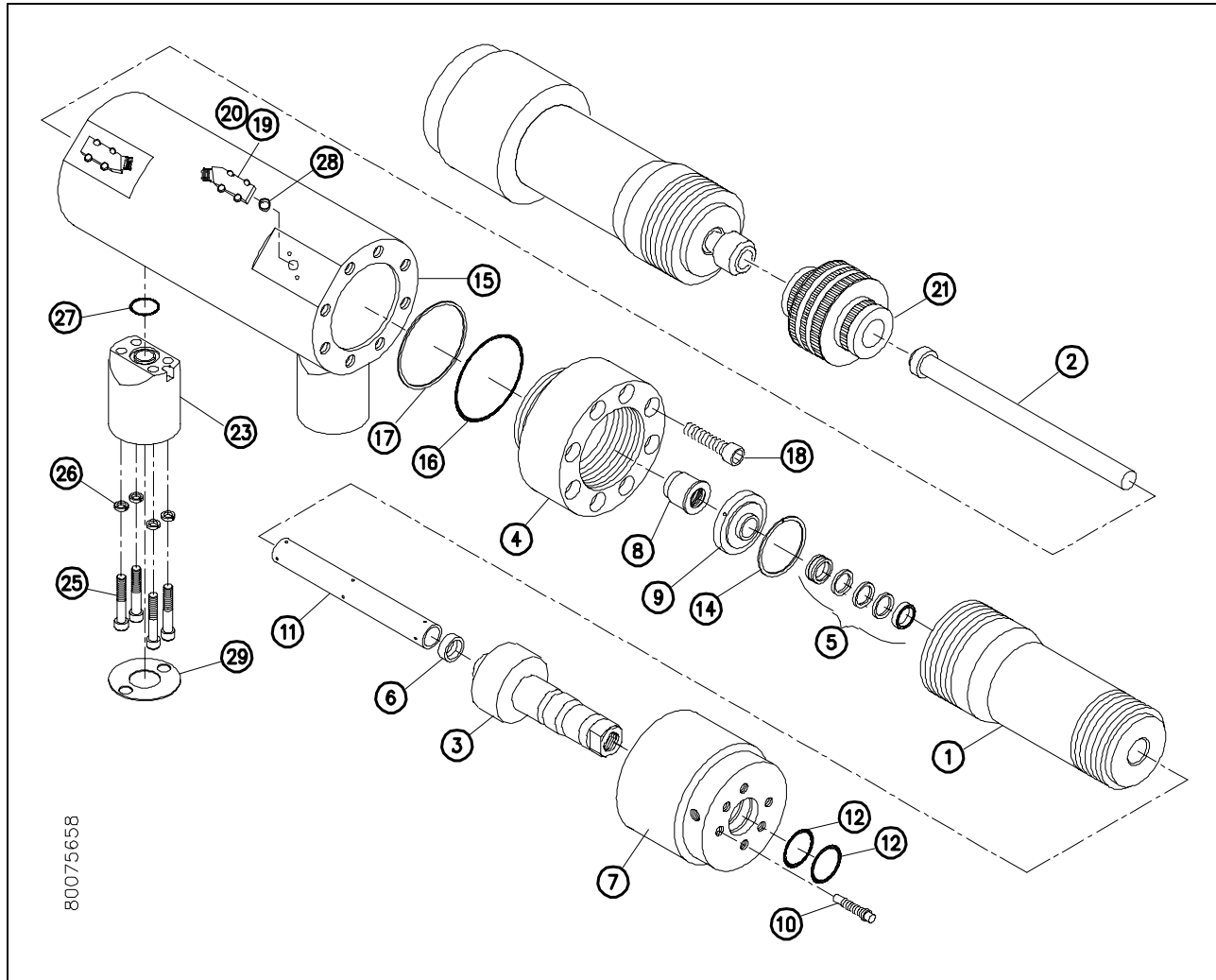




**Table 12-2**  
**Intensifier Assembly**  
**20429675**

Item	Part Number	Description	Quantity	Item	Part Number	Description	Quantity
1	20429683	HP Cylinder Body	2	15	05144514	Hydraulic Cylinder, 5.50	1
2	20444534	Plunger, 1.50	2	16	05120092	Backup Ring, 5.25 x 5.50	2
3	20429698	Sealing Head Assembly	2	17	10074771	O-Ring, 5.25 x 5.50 x 0.13	2
4	20429797	Hydraulic Cylinder Head	2	18	20413955	Socket Head Screw, 3/4-16 x 3-1/4	12
5	20429724	HP Seal Assembly, 1.50	2	19	05130224	Proximity Switch, 20-250V AC/DC	2
6	20429756	Spacer, Sealing Head	2	20	95119012	Socket Head Screw, 1/4 x 20 x 1	4
7	49838220	HP Cylinder Nut, HSEC	2	21	05146576	Piston Assembly, 5.50	1
8	20429980	Hydraulic Cartridge Seal Assembly	2	23	05144522	Stem	2
9	20429823	Bushing Retainer Flange	2	25	05041058	Socket Head Screw, 3/8-16 x 2-1/4	8
10	80070352	Jackbolt, 7/16-20 x 2.31, 3/8 Hex Head	16	26	95688743	Lock Washer, 0.38	8
11	20429774	Liner, HP Cylinder	2	27	10118206	O-Ring, 1.31 x 1.56x 0.13	2
12	10074920	O-Ring, 1.75 x 0.94 x 0.09	4	28	05144183	Spacer, Proximity Switch	2
14	05034798	Retaining Ring	2	29	05146592	Gasket, Stem/Upper Drip Pan	2

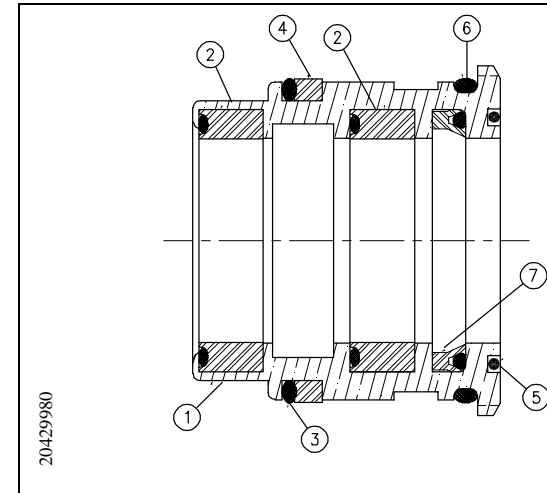
Figure 12-2: Intensifier Assembly



**Table 12-3**  
**Hydraulic Cartridge Seal**  
**20429980**

Item	Part Number	Description	Quantity
1	20429987	Seal Bushing	1
2	20430029	Packing Ring, 1.75 x 1.50 x 0.25	2
3	20430021	O-Ring, 1.81 x 2.0 x 0.09	1
4	20430005	Backup Ring, 1.81 x 2.0	1
5	20430055	O-Ring, 1.63 x 1.75 x 0.06	1
6	20430013	O-Ring, 1.88 x 2.0 x 0.06	1
7	20430037	U-Cup Seal, 150 x 1.75 x 0.13	1

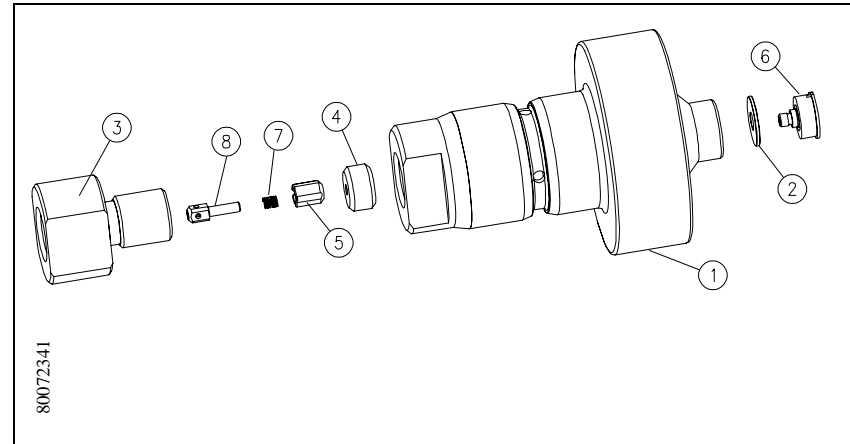
*Figure 12-3: Hydraulic Cartridge Seal*



**Table 12-4**  
**Sealing Head Assembly**  
**20429698**

Item	Part Number	Description	Quantity
1	20429706	Sealing Head Body	1
2	20432760	Inlet Poppet Valve	1
3	05116595	Gland Nut	1
4	05116579	Seat	1
5	05116603	Discharge Poppet Valve	1
6	05119698	Poppet Retainer	1
7	05147863	Compression Spring	1
8	05119839	Poppet Pin	1

*Figure 12-4: Sealing Head Assembly*

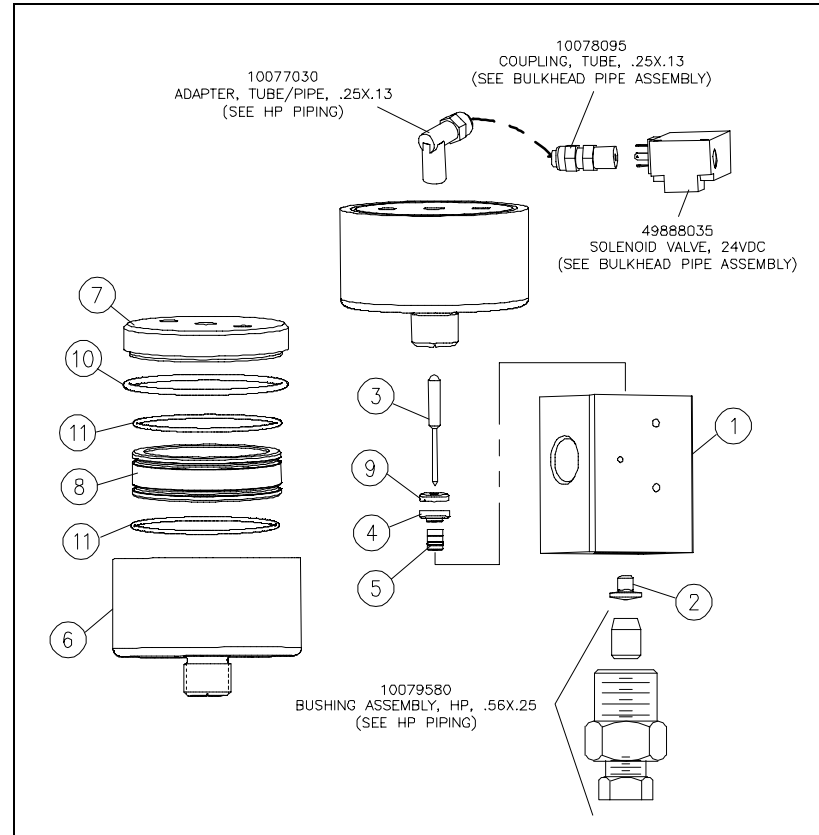




**Table 12-5**  
**Pneumatic Valve/Actuator Assembly, Normally Open**  
**10184760**

<b>Item</b>	<b>Part Number</b>	<b>Description</b>	<b>Quantity</b>	<b>Item</b>	<b>Part Number</b>	<b>Description</b>	<b>Quantity</b>
1	10189181	Valve Body	1		10189553	Actuator Assembly, Normally Open	
2	10178697	Valve Seat	1	6	BV401184	Pneumatic Cylinder	1
3	20435636	Valve Stem	1	7	BV601184	Cylinder Head	1
4	10188233	Backup Ring, Brass	1	8	BV501184	Piston	1
5	20428052	Seal Assembly	1	9	10187250	Backup Ring, SST	1
				10	10074715	O-Ring, 2.44 x 2.63 x .09	1
				11	10074565	O-Ring, 2.25 x 2.38 x .06	2

Figure 12-5: Pneumatic Valve/Actuator Assembly, Normally Open



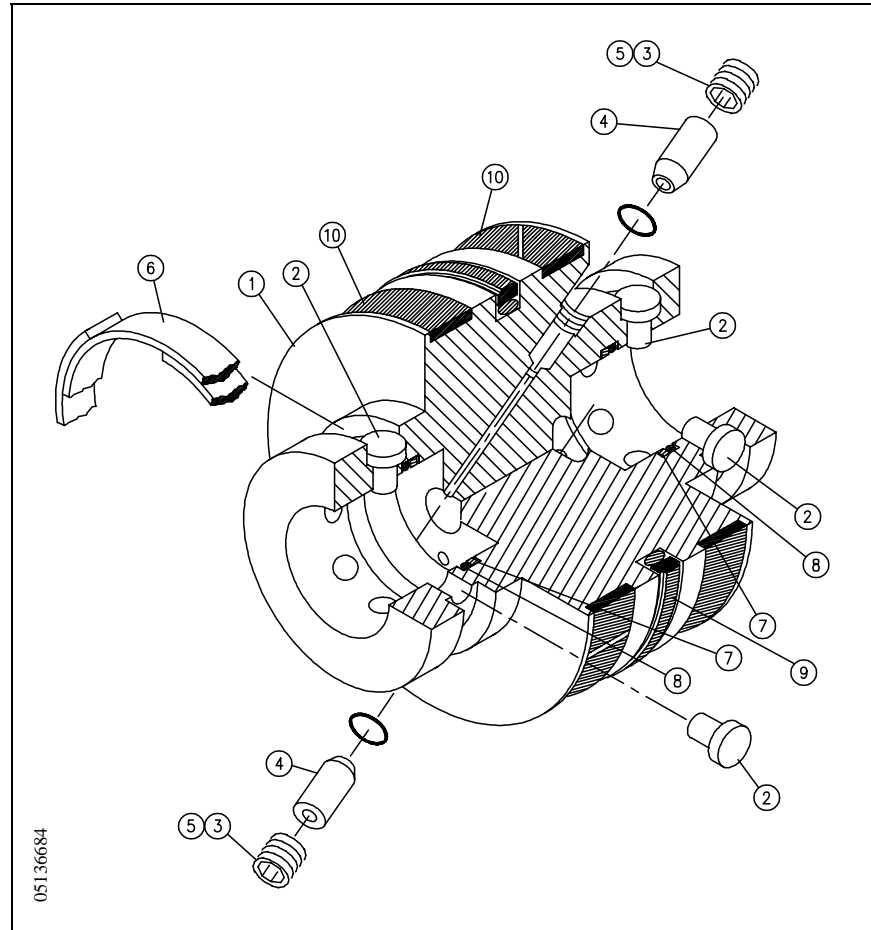




**Table 12-6**  
**Hydraulic Piston Assembly**  
**05146576**

<b>Item</b>	<b>Part Number</b>	<b>Description</b>	<b>Quantity</b>
1	05144589	Hydraulic Ram Piston, 5.50	1
2	05074380	Plunger Retainer Pin, Clevis, 0.25 x 0.43	12
3	05049887	Set Screw, Socket, 3/8-16 x 3/8	2
4	10148757	Check Valve Cartridge W/O-Ring	2
5	49877509	Adhesive, Thread Locker	.001
6	05130216	Flat Snap Ring, 0.032 x 0.375 x 2.20	2
7	05146568	Backup Ring, 1.50 x 1.75 x 0.125	2
8	10074821	O-Ring, 1-1/2 x 1-3/4 x 1/8	2
9	05120118	Seal Assembly, Hydraulic Piston	1
10	05120100	Bearing Ring, Hydraulic Piston	2
	<b>80085079</b>	<b>Rebuild Kit</b>	
		Includes Items 4, 6, 7, 8, 9 and 10	

Figure 12-6: Hydraulic Piston Assembly

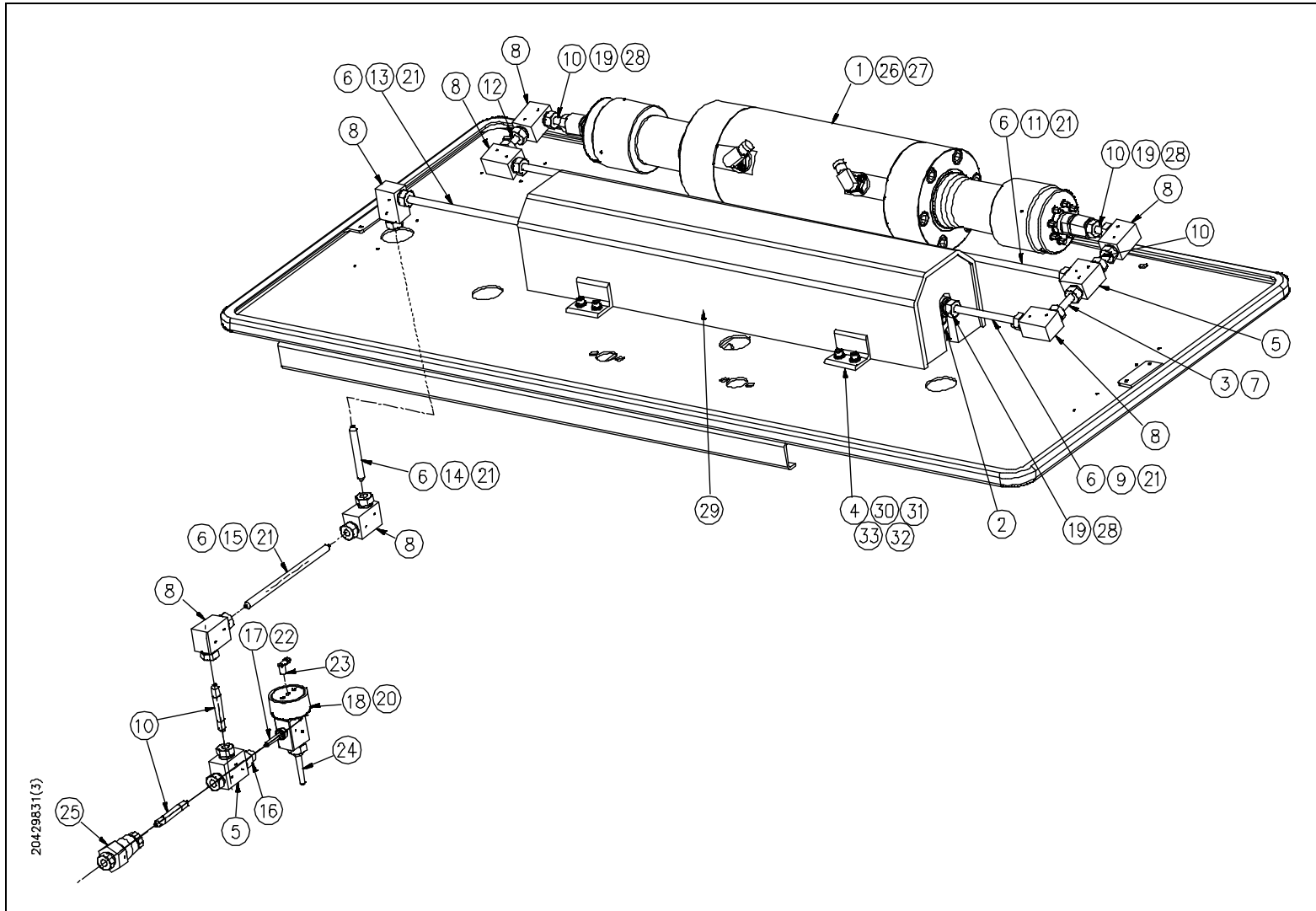




**Table 12-7**  
**High Pressure Piping**  
**20432786**

Item	Part Number	Description	Quantity	Item	Part Number	Description	Quantity
1	20429675	Intensifier Assembly	1	16	10079457	HP Bushing, 0.56 x 0.38	1
2	20413237	Attenuator Assembly, 2 Liter	1	17	10094704	HP Tube, 0.38 x 0.125 x 3.0, Cone/Thread	1
3	20417180	SST Tube	1	18	10184760	Pneumatic Valve/Actuator Assembly	1
4	05144837	Spacer, Dual Attenuator Bracket	4	19	10078608	HP Gland, 0.56	3
5	10079465	HP Tee, 0.56	2	20	10079580	HP Bushing, 0.56 x 0.25	1
6	05131347	Ferrule, 0.50 Hose	10	21	05086905	Conduit, 0.63 ID	180.0"
7	05112057	HP Tube, 0.56 x 0.188 x 4.97, Cone/Thread	1	22	10078913	HP Gland, Anti-Vibration, 0.38	1
8	10078525	HP Elbow, 0.56 x 0.56	7	23	10077030	Adapter, Tube/Pipe,, 0.25 x 0.13, 90D	1
9	49895642	HP Tube, 0.56 x 0.188 x 9.25, Cone/Thread	1	24	05112552	HP Tube, 0.25 x 0.83 x 34.0, Cone/Thread	1
10	10069326	HP Tube, 0.56 x 0.188 x 4.0, Cone/Thread	5	25	10079705	HP Coupling, 0.56 x 0.56	1
11	05145271	HP Tube, 0.56 x 0.188 x 55.19	1	26	95413696	Lock Washer, 0.50	4
12	05145297	HP Tube, 0.56 x 0.188 x 4.18	1	27	95383790	Socket Head Screw, 1/2-13 x 1.0	4
13	20429847	HP Tube, 0.56 x 0.188 x 16.3, Cone/Thread	1	28	10079119	HP Collar, 0.56	3
14	05074661	HP Tube, 0.56 x 0.188 x 4.59, Cone/Thread	1	29	20424324	Attenuator Housing	1
15	05109939	HP Tube, 0.56 x 0.188 x 10.7, Cone/Thread	1	30	95375473	Socket Head Screw, 3/8-16 x 1.0	8
				31	95670972	Lock Washer, 0.38	8
				32	95660957	Flat Washer, 0.38	8
				33	05103023	PED Decal	1

Figure 12-7: High Pressure Piping

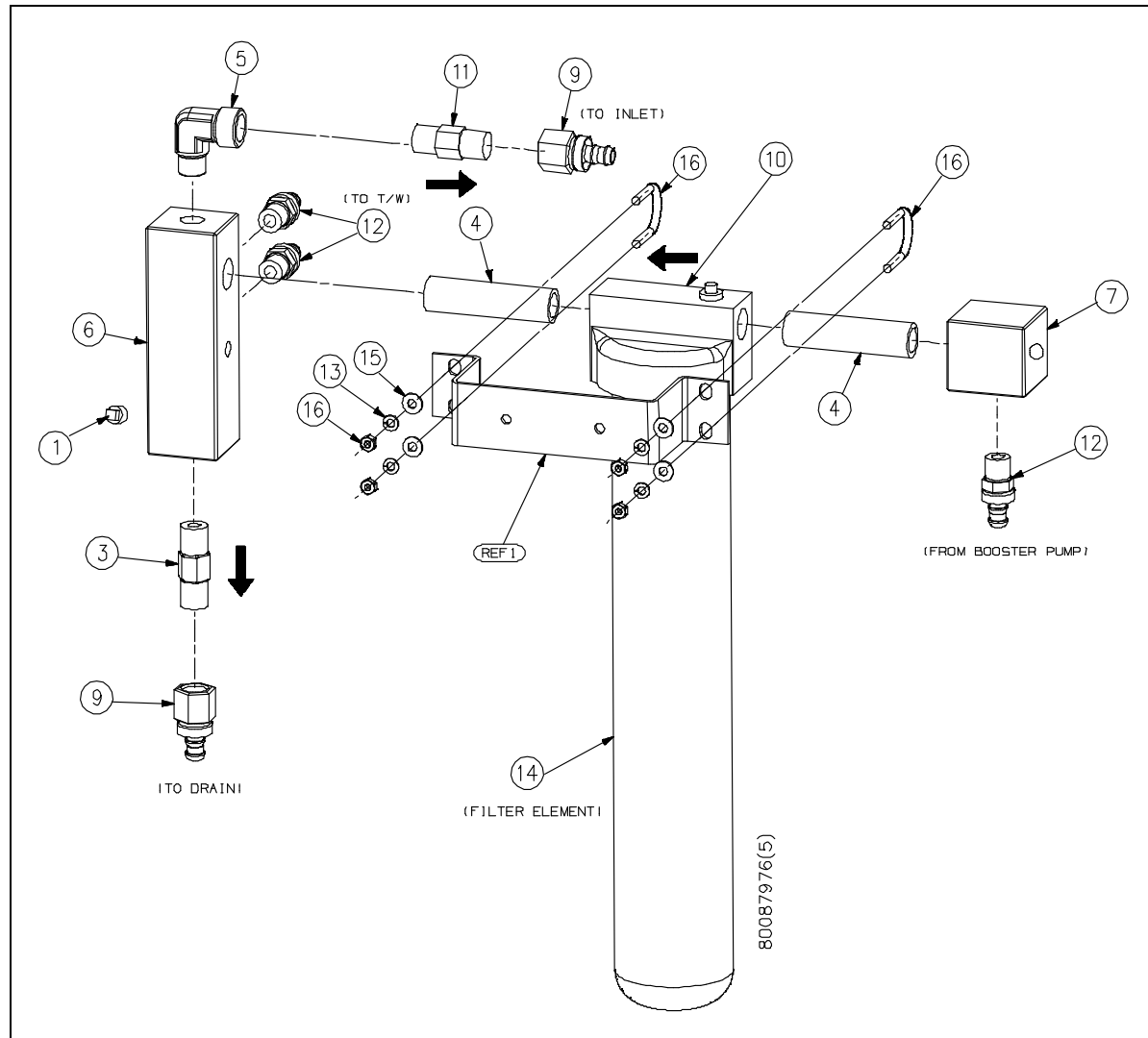




**Table 12-8**  
**Low Pressure Water Filter Assembly**  
**80087976**

<b>Item</b>	<b>Part Number</b>	<b>Description</b>	<b>Quantity</b>	<b>Item</b>	<b>Part Number</b>	<b>Description</b>	<b>Quantity</b>
1	05135637	Plug, Pipe, .25	1	10	05038690	Water Filter Body	1
3	05070982	Relief Valve, 50-150 psi	1	11	05135652	Check Valve, Inlet/Outlet	1
4	49838386	Pipe Nipple, .75 x 4.0	2	12	49833882	Adapter, ORB/Hose, .50 x .50	3
5	10119253	Elbow, Pipe, .50 x .50	1	13	95838314	Lock Washer, .25	4
6	20413848	Manifold, LP Water Outlet	1	14	49834716	Filter Element, 10 Micron	1
7	49833924	Low Pressure Manifold, Left	1	15	95391322	Flat Washer, .25	4
9	49835804	Adapter, Pipe/Hose, .50 x .50	2	16	10083384	U-Bolt, .75	2
				Ref 1	05073630	Mounting Bracket	--

Figure 12-8: Low Pressure Water Filter Assembly

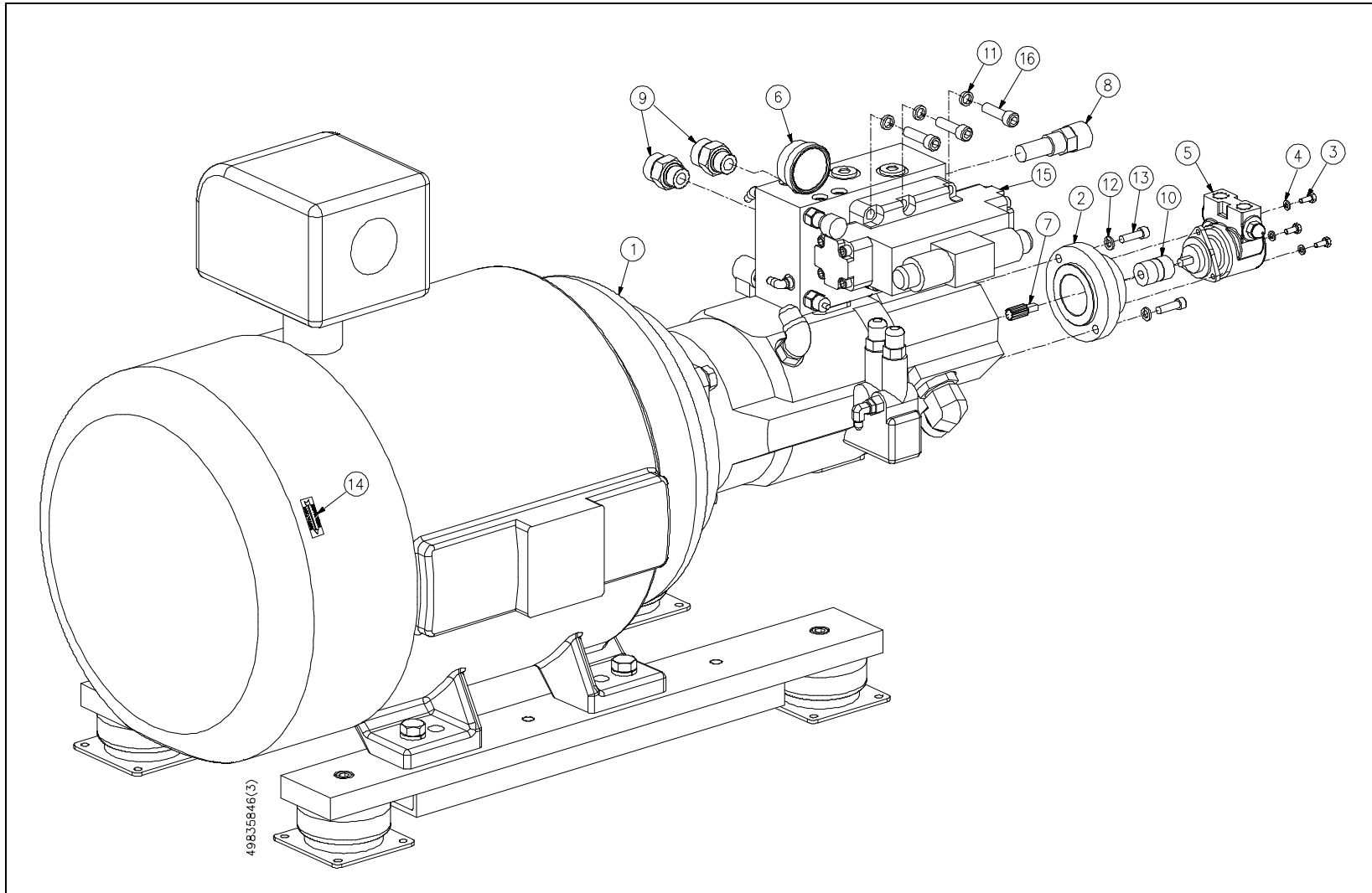




**Table 12-9**  
**Hydraulic Power Package**  
**20435207/20428358**

<b>Item</b>	<b>Part Number</b>	<b>Description</b>	<b>Quantity</b>
1	80076458	Motor/Pump Assembly, 100 HP, 230, 380-415/50/60	1
	20428316	Motor/Pump Assembly, 100 HP, 200-208/50/60	
2	05103411	Adapter, Water Pump	1
3	95572897	Hex Head Screw, 1/4-20 x 5/8	3
4	95838314	Lock Washer, .25	3
5	20433281	Water Pump, Vane	1
6	20432794	Pressure Gauge, 0-5000 psi	1
7	05103429	Shaft Spline	1
8	05071717	Relief Valve	1
9	80079684	Adapter, FSOR/ORB, 1.0 x .75	2
10	05103395	Shaft Coupling	1
11	95688750	Lock Washer, .50	6
12	95750394	Lock Washer, .38	2
13	05041033	Socket Head Screw, 3/8-16/3 x 1-1/4	2
14	10091510	Arrow Decal	1
15	20437206	Directional Control Valve, 24V DC	1
16	95055059	Socket Head Screw, 1/2-13 x 2-1/2	6

Figure 12-9: Hydraulic Power Package



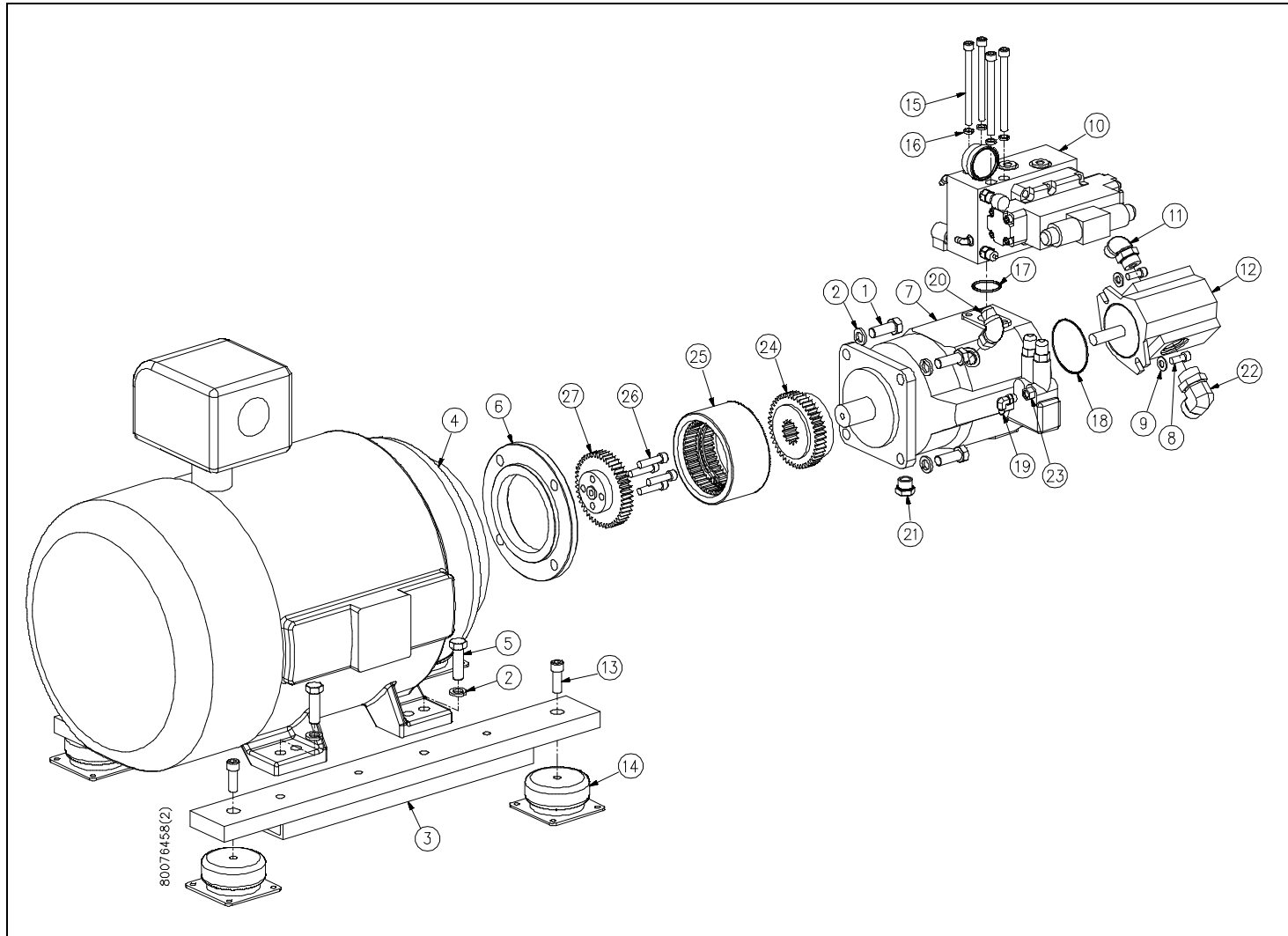




**Table 12-10**  
**Motor/Pump Assembly**  
**20428316/80076458**

Item	Part Number	Description	Quantity	Item	Part Number	Description	Quantity
1	10075877	Hex Head Screw, 3/4-10 x 2-3/4	4	14	05103254	Vibration Isolation Mount	4
2	95688735	Lock Washer, .75	8	15	05103247	Socket Head Screw, 1/2-13 x 6	4
3	05103205	Motor Mount	2	16	95688750	Lock Washer, .50	4
4	80083876	Electric Motor, 100 HP, 200-208/3/50/60	1	17	49882087	O-Ring, 1.88 x 2.13 x 0.13	1
	80076581	Electric Motor, 100 HP, 230, 380-415/50-60		18	05112727	O-Ring, Pump Seal	1
5	10066256	Hex Head Screw, 3/4-10 x 2-1/2	4	19	05085758	Adapter, ORB/JIC, .38 x .25	1
6	80076656	Flange, Motor/Pump Adapter	1	20	10091163	Adapter, JIC/ORB, .75 x .75	1
7	05103239	Piston Pump, 3000 psi	1	21	10118057	Plug, ORB, .75	1
8	10192961	Socket Head Screw, M12 x 1.75 x 30 mm	2	22	10099760	Adapter, JIC/ORB, 1.25 x 1.25	1
9	10069763	Flat Washer, .50	2	23	05139639	Adapter, M14 x 4, M/F, O-Ring	1
10	49835796	Manifold Assembly	1	24	80076664	Coupling, Flexible Drive, D-Spline	1
11	10151470	Adapter, ORB/JIC, 1.0 x .75	1	25	80076649	Flexible Drive Coupling Insert	1
12	05091301	Gear Pump, Single Shaft	1	26	95055034	Socket Head Screw, 1/2-13 x 2	4
13	95013694	Socket Head Screw, 5/8-11 x 1-3/4	4	27	80076672	Coupling, Flexible Drive, Motor Shaft	1

Figure 12-10: Motor/Pump Assembly

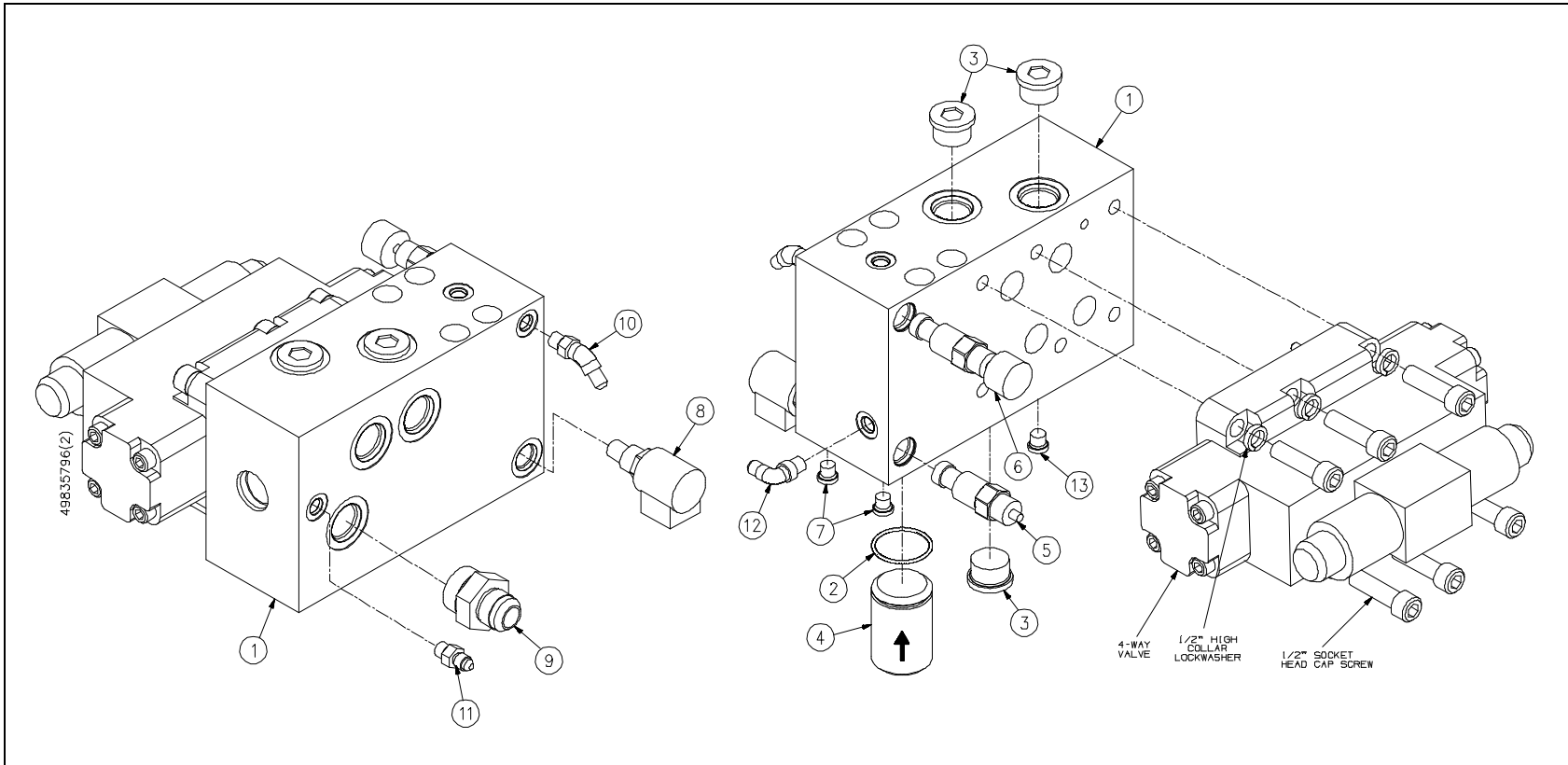




**Table 12-11**  
**Hydraulic Manifold Assembly**  
**49835796**

<b>Item</b>	<b>Part Number</b>	<b>Description</b>	<b>Quantity</b>
1	05103197	Hydraulic Manifold Block	1
2	10187417	O-Ring, 1.50 x 1.69 x .09	1
3	05071055	Plug, ORB, .75	3
4	05103189	Cartridge Check Valve	1
5	10187060	Relief Valve, 25-1500 psi	1
6	10187052	Relief Valve, 25-3000 psi	1
7	05055017	Plug, ORB, .13	2
8	10185585	Solenoid Valve, 24V DC	1
9	05064407	Adapter, JIC/ORB, 1.0 x .75	1
10	10144749	Adapter, JIC/ORB, .25 x .25	1
11	49876089	Adapter, JIC/ORB, .25 x .25	1
12	10142644	Adapter, JIC/ORB, .25 x .25	1
13	49889769	Plug, ORB, .25	1

Figure 12-11: Hydraulic Manifold Assembly

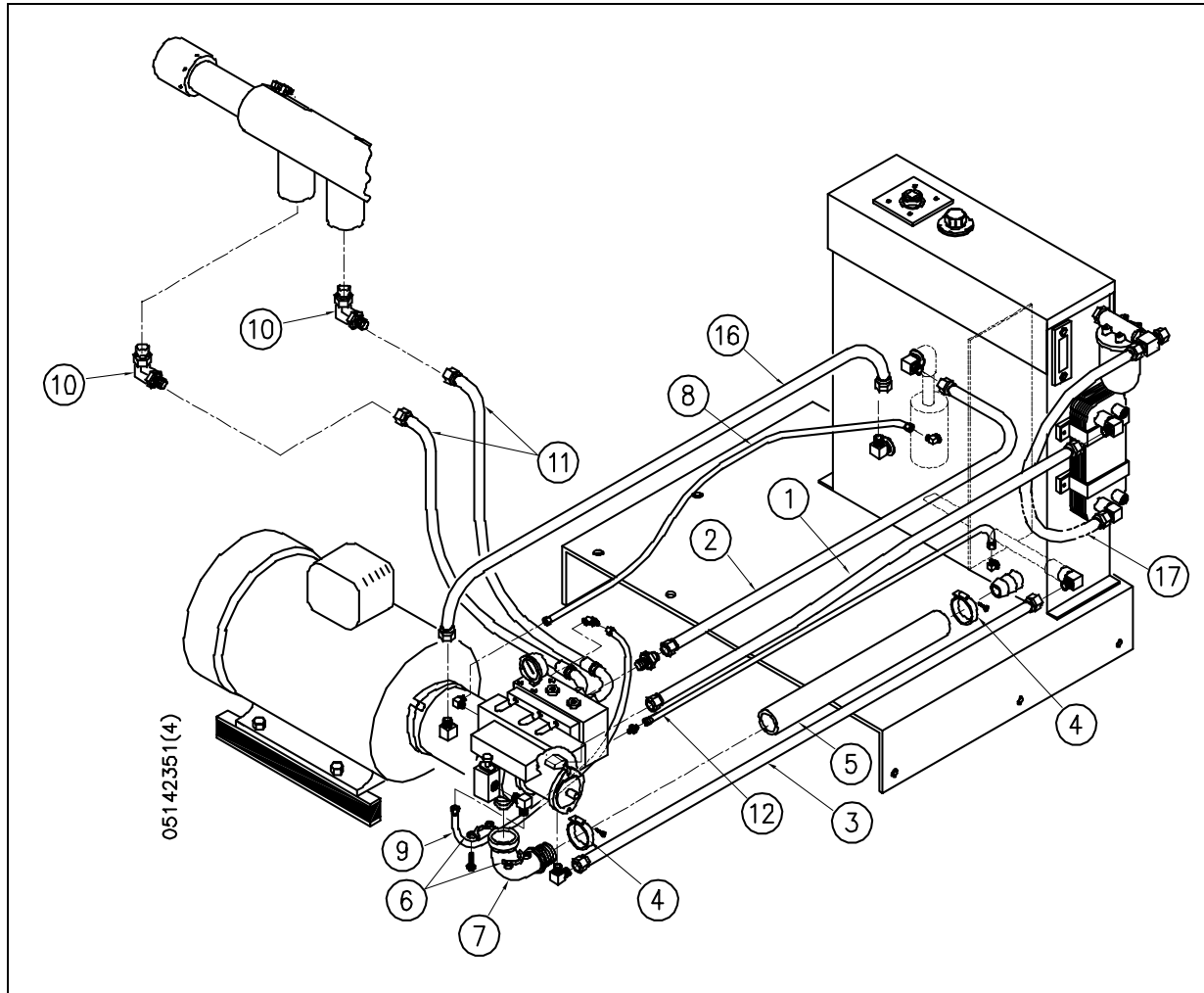




**Table 12-12**  
**Hydraulic Hose Connections**  
**05142351**

<b>Item</b>	<b>Part Number</b>	<b>Description</b>	<b>Quantity</b>	<b>Item</b>	<b>Part Number</b>	<b>Description</b>	<b>Quantity</b>
1	05106950	Hydraulic Hose Assembly, .75 x 19.0	1	11	80079536	Hydraulic Hose Assembly, 1.0 x 36.0	2
2	05106968	Hydraulic Hose Assembly, 1.25 x 26.50	1	12	80085889	Hydraulic Hose Assembly, .25 x 20.0	1
3	05106976	Hydraulic Hose Assembly, 1.25 x 24.50	1	13	05061163	Hydraulic Hose Assembly, .75 x 31.0	1
4	20419045	Hose Clamp, 3.0	2	14	05049713	Hydraulic Hose Assembly, .75 x 27.0	1
5	10079754	Radiator Hose, 2.50	10.5"				
6	49872245	Split Flange, 2.50	1				
7	05106984	Adapter, Hose/Flange, 2.50 x 2.50	1				
8	05112750	Hydraulic Hose Assembly, .25 x 26.0	1				
9	05051214	Hydraulic Hose Assembly, .25 x 39.0	1				
10	80079809	Adapter, FSOR/ORB, 1.0 x .75	2				

Figure 12-12: Hydraulic Hose Connections

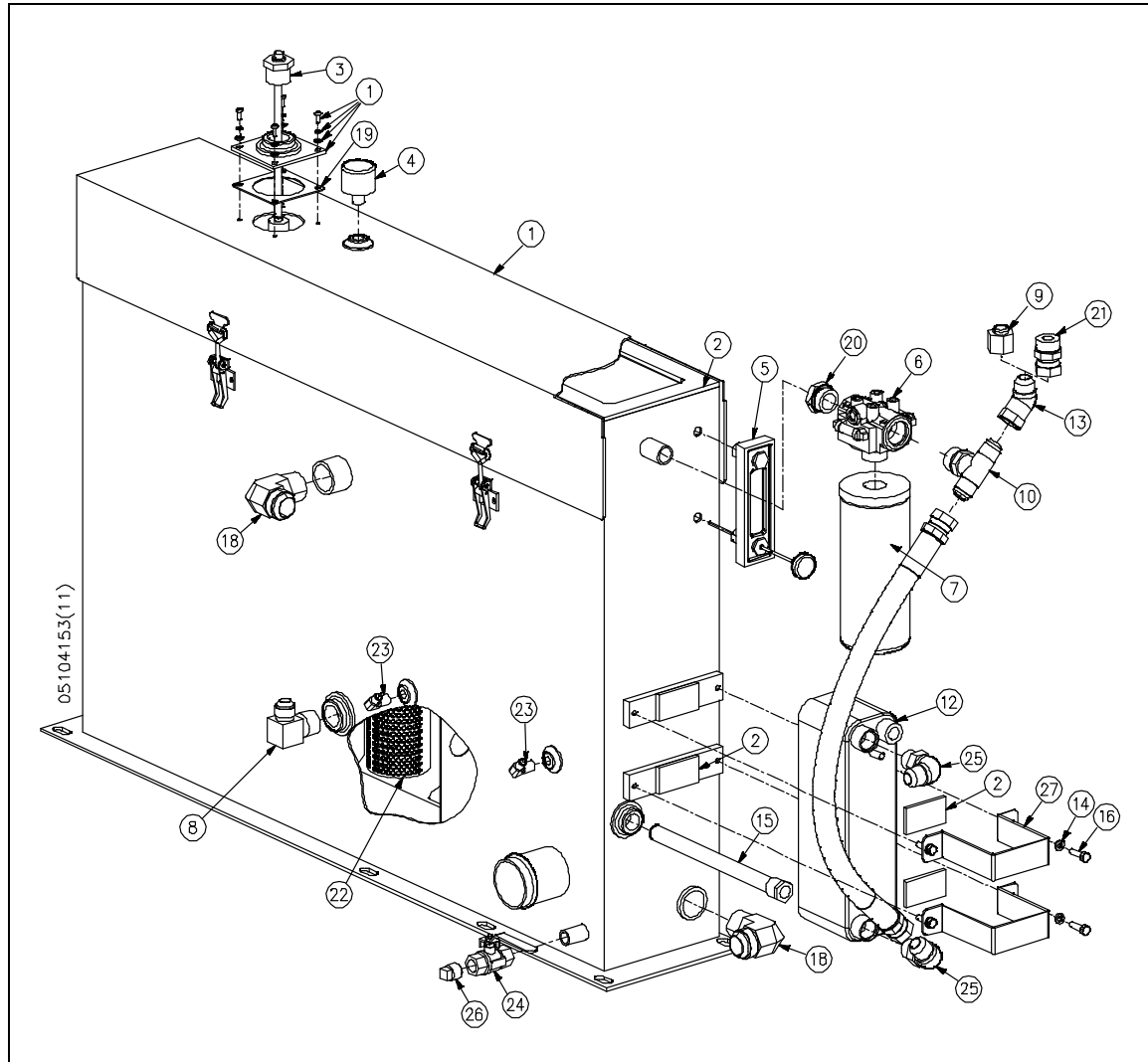




**Table 12-13**  
**Reservoir Assembly**  
**05104153**

<b>Item</b>	<b>Part Number</b>	<b>Description</b>	<b>Quantity</b>	<b>Item</b>	<b>Part Number</b>	<b>Description</b>	<b>Quantity</b>
1	20444146	Reservoir Weldment	1	16	95829248	Hex Head Screw, 5/16-18 x 1	4
2	05104179	Gasket, Reservoir	1	18	20424011	Adapter, JIC/ORB, 1.25 x 1.25	2
3	05050026	Temperature/Level Switch	1	19	05079967	Gasket, Oil Sensor	1
4	05092739	Air Breather	1	20	10170645	Adapter, ORB/Pipe, 1.0 x .75	1
5	20451474	Level/Temperature Gauge	1	21	05079371	Adapter, JIC/BSPP, .75 x .75	1
6	05103809	Hydraulic Filter Head	1	22	05006291	Diffuser, Return Line	1
7	05104187	Oil Filter Element	1	23	10142644	Adapter, JIC/ORB, .25 x .25	2
8	10151470	Adapter, ORB/JIC, 1.0 x .75	1	24	10080901	Ball Valve	1
9	05069976	Cap, .75	1	25	10091163	Adapter, JIC/ORB, .75 x .75	2
10	20455107	Tee, ORB/JIC, .75 x 1.0	1	26	95033619	Plug, Pipe, .50	1
12	05145941	Heat Exchanger	1	27	05145966	Bracket, Heat Exchanger	2
13	05060777	Elbow, JIC, .75 x .75	1				
14	95830766	Lock Washer, .31	4				
15	10091858	Bulb, Well	1				

Figure 12-13: Reservoir Assembly







**Table 12-14**  
**Bulkhead Pipe Assembly**  
**20436131**

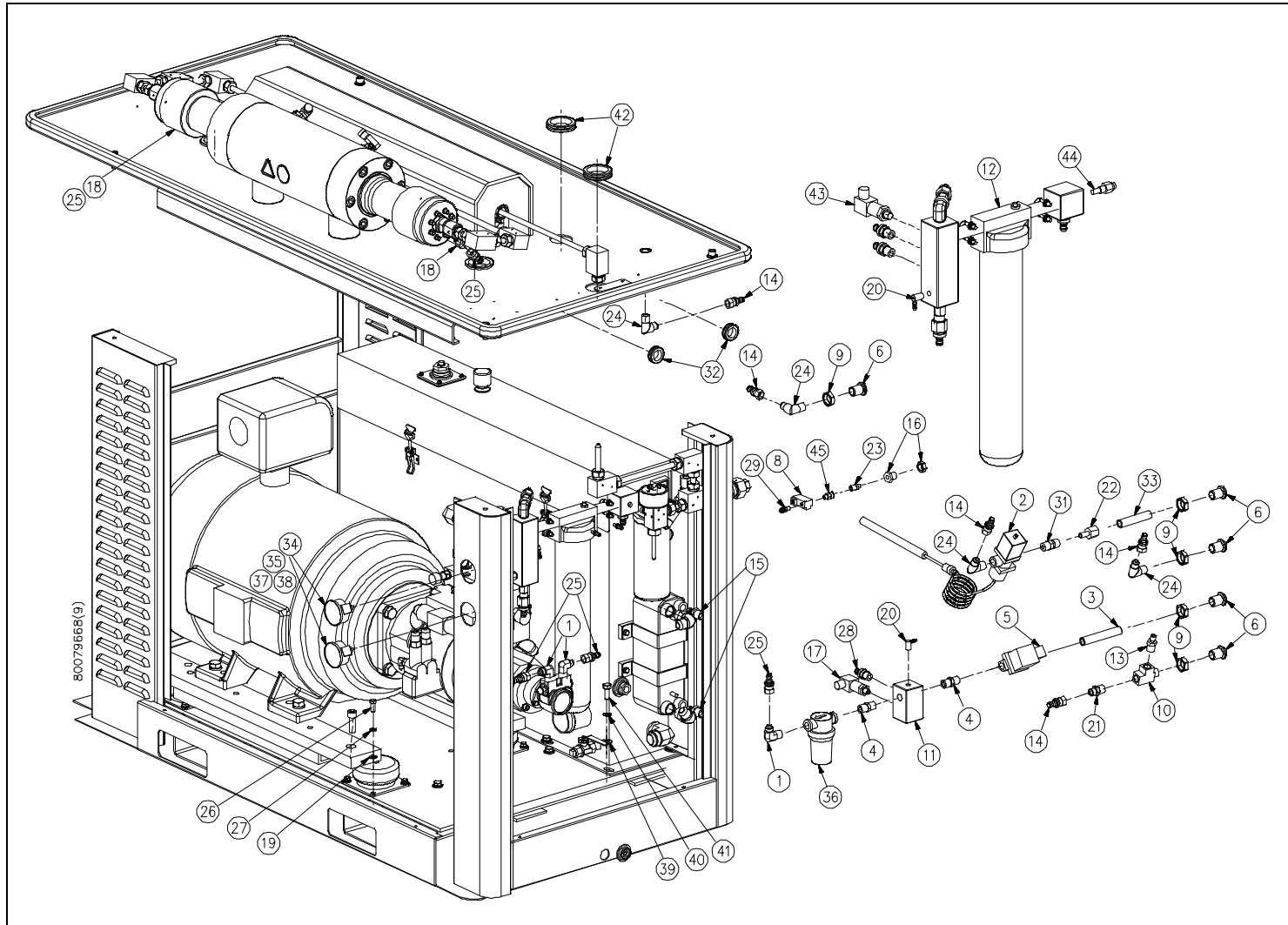
Item	Part Number	Description	Quantity	Item	Part Number	Description	Quantity
1	49887011	Adapter, JIC/Pipe, .50 x .50	3	20	49830714	Adapter, Hose/Pipe, .25 x .25	2
2	10091866	Water Modulating Valve	1	21	95157418	Adapter, JIC/Pipe, .50 x .50	1
3	05060207	Pipe Nipple, .50 x 5.0	1	22	49834302	Adapter, Tube/Pipe, .50 x .50	1
4	10100436	Coupling, Pipe, .50 x .50	2	23	10078335	Coupling, Pipe, .25 x .13	1
5	05024815	Solenoid Valve, 24V DC, 2-Way	1	24	95680922	Adapter, Pipe/JIC, .50 x .50	4
6	49886922	Adapter, Bulkhead, .50 x .50	5	25	10189025	Adapter, Hose/JIC, .50 x .50	5
7	10127348	Hose, Push On, .50	230.0"	26	95416319	Hex Head Screw, 3/8-16 x 1	16
8	49888035	Solenoid Valve, 24V	1	27	95750394	Lock Washer, .38	16
9	10070092	Jam Nut, 1-14	5	28	05135660	Adapter, JIC/ORB, .50 x .50	1
10	10073823	Tee, .50 x .50	1	29	10078095	Coupling, Tube, .25 x .13	1
11	20413789	Manifold, LP Water Inlet	1	30	10079903	Tube, Clear, 0.25	36.0"
12	80087976	LP Water Filter Assembly	1	31	49834310	Adapter, Tube/Pipe, .50 x .50	1
13	49834328	Adapter, Pipe/Tube, .25 x .50	1	32	05113964	Grommet, Rubber, 1.75	6
14	10173805	Adapter, Hose/JIC, .50 x .50	5	33	10084523	Pipe Nipple, .50 x 4.0	1
15	10079713	Hose Barb, .50	2	34	05139506	Pressure Gauge, 0-200 psi	2
16	10077055	Adapter, Bulkhead, .25 x .25	1	35	10084226	Hydraulic Hose, .25, LP	72.0"
17	05140751	Pressure Switch, 30 psi	1	36	20412815	Filter, In-Line Strainer	1
18	05111406	Adapter, JIC/Pipe, .25 x .50	2	37	49830722	Adapter, Pipe/Hose, .25 x .25	2
19	10069714	Flat Washer, .38	16	38	95146429	Hex Nut Screw, #8-32	4



**Table 12-14**  
**Bulkhead Pipe Assembly**  
**20436131**

<b>Item</b>	<b>Part Number</b>	<b>Description</b>	<b>Quantity</b>	<b>Item</b>	<b>Part Number</b>	<b>Description</b>	<b>Quantity</b>
39	10069763	Flat Washer, .50	6	43	05140751	Pressure Switch, 30 psi	1
40	95716890	Lock Washer, .50	6	44	49868813	Temperature Sensor	1
41	95716882	Hex Head Screw, 1/2-13 x 1-1/4	6	45	20453730	Check Valve	1
42	49831480	Grommet, Rubber, 3.00 x 2.25	7				

Figure 12-14: Bulkhead Pipe Assembly

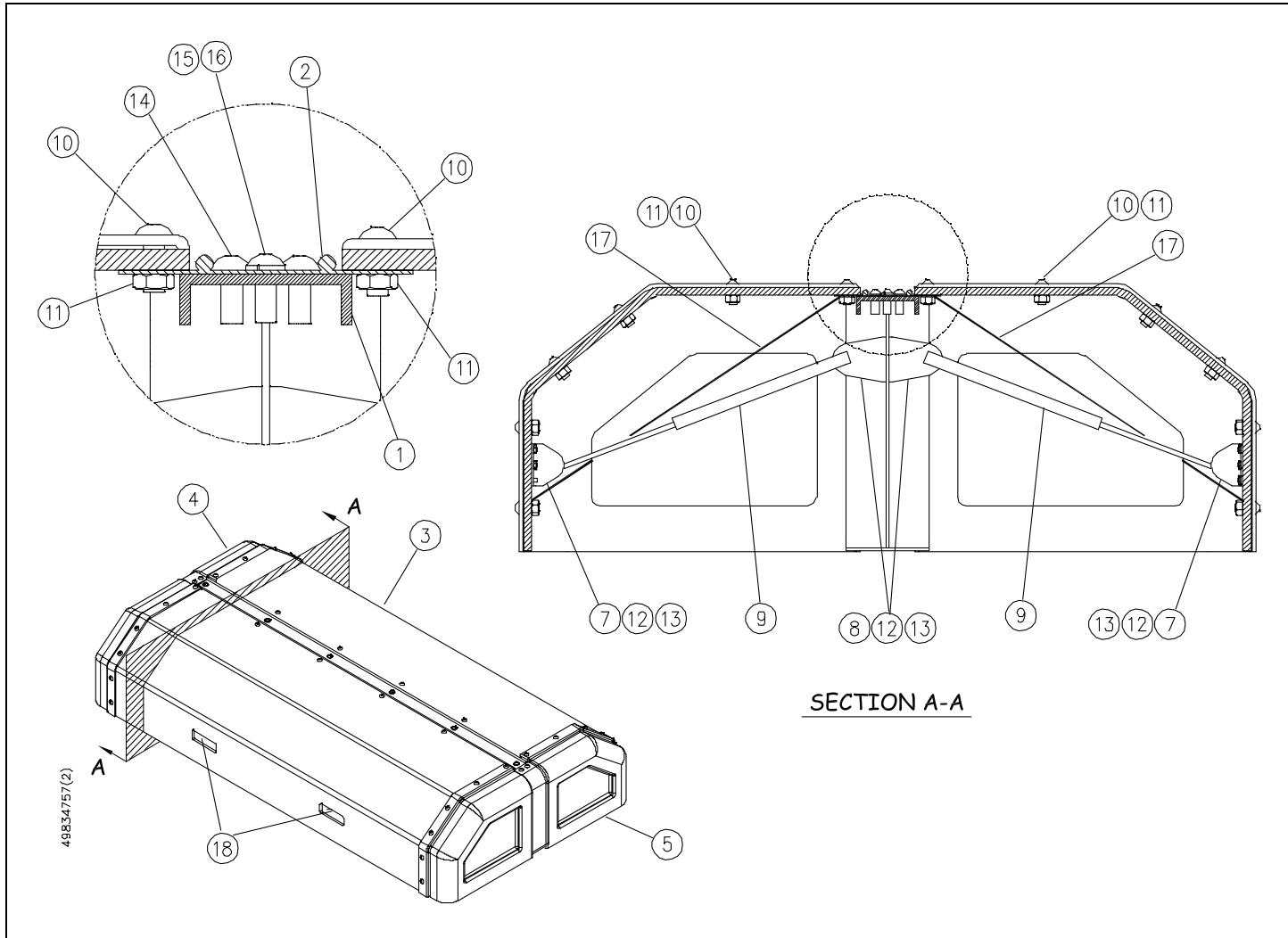




**Table 12-15**  
**Cover Assembly**  
**80074768**

<b>Item</b>	<b>Part Number</b>	<b>Description</b>	<b>Quantity</b>
1	80074750	Support Assembly	1
2	80074735	Multi-Pin Hinge	1
3	80074727	Cover, Top	2
4	49834708	Cover, Left End	2
5	49834690	Cover, Right End	2
7	49837511	Mounting Bracket	4
8	49837529	Mounting Bracket	4
9	49837503	Spring, Gas	4
10	49837743	Flange Head Screw, Button Head, 3/8-16 x 1.0	32
11	05091988	Flange Nut, 3/8-16	32
12	95897948	Button Head Screw, 10-24 x 1/2	24
13	49832181	Flange Nut, #10-24	24
14	80074719	Gasket, Not Shown	1
15	95670972	Lock Washer, .38	6
16	05091954	Button Head Screw, 3/8-16 x 1.00	6
17	80076748	Cable, Lanyard, 18.75	4
18	49837826	Handle, Pocket Pull, Flush	4

Figure 12-15: Cover Assembly

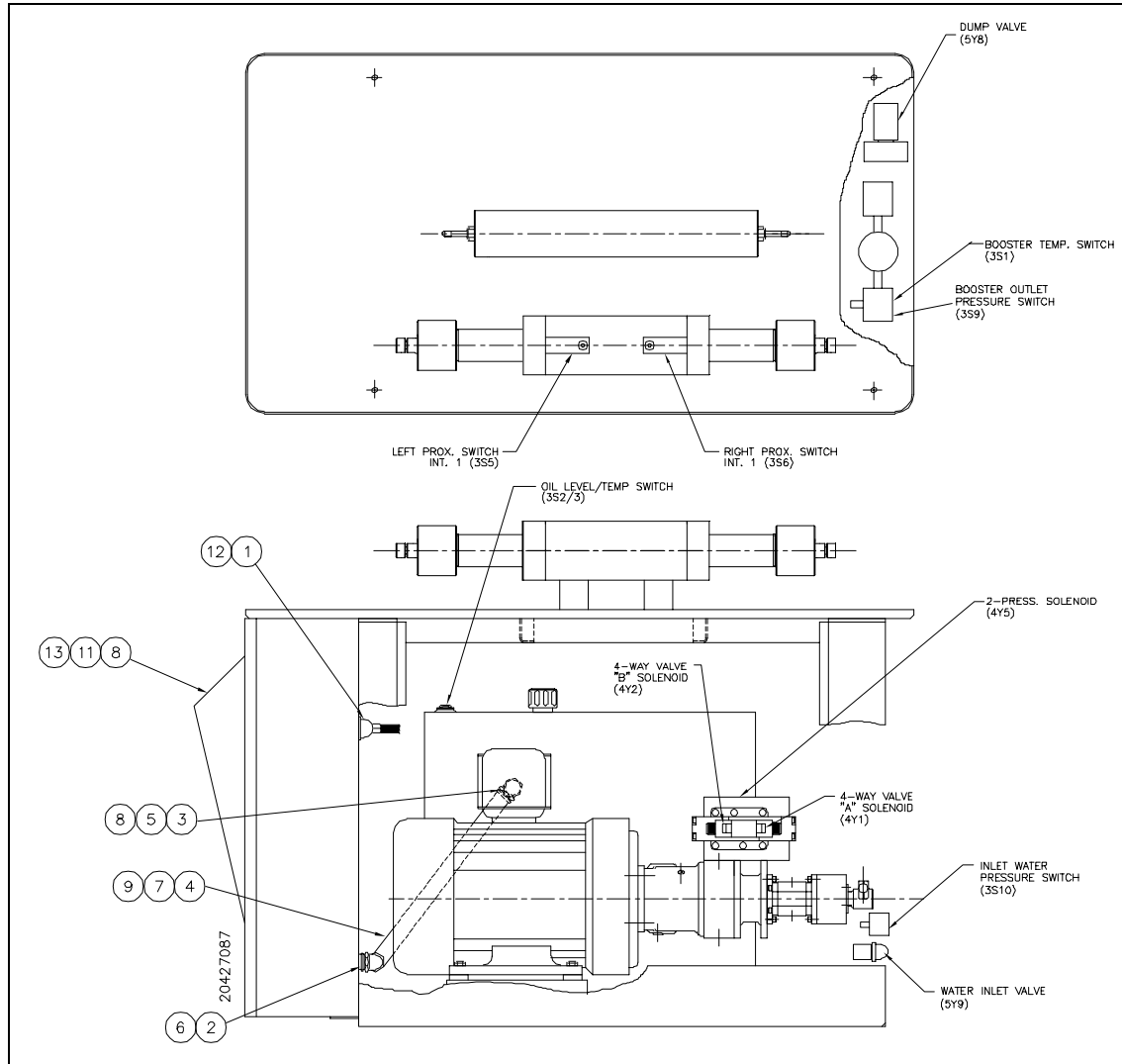




**Table 12-16**  
**Electrical Assembly, 200-208/50-60**  
**20427087**

<b>Item</b>	<b>Part Number</b>	<b>Description</b>	<b>Quantity</b>
1	05148531	Harness, Sensor/Solenoid Cable	1
2	20427069	Flexible Conduit Connector, 2.50	1
3	80080344	Terminal Lug, #10-250	9
4	20426246	Flexible Conduit, 2.50	42.0"
5	20426262	Flexible Conduit Connector, 2.50	1
6	20426254	Conduit Bushing, 2.50 x 2.50	1
7	10069763	Flat Washer, .50	4
8	20451607	Weld Cable	360.0"
9	05139498	Wire, #3, Green	60.0"
11	05097464	Ring Terminal, #4, 0.312	2
12	95716890	Lock Washer, .50	4
13	10125912	Cable Tie, .87	5
14	20413542	Starter/Control Panel Configuration	1

Figure 12-16: Electrical Assembly, 200-208/50-60



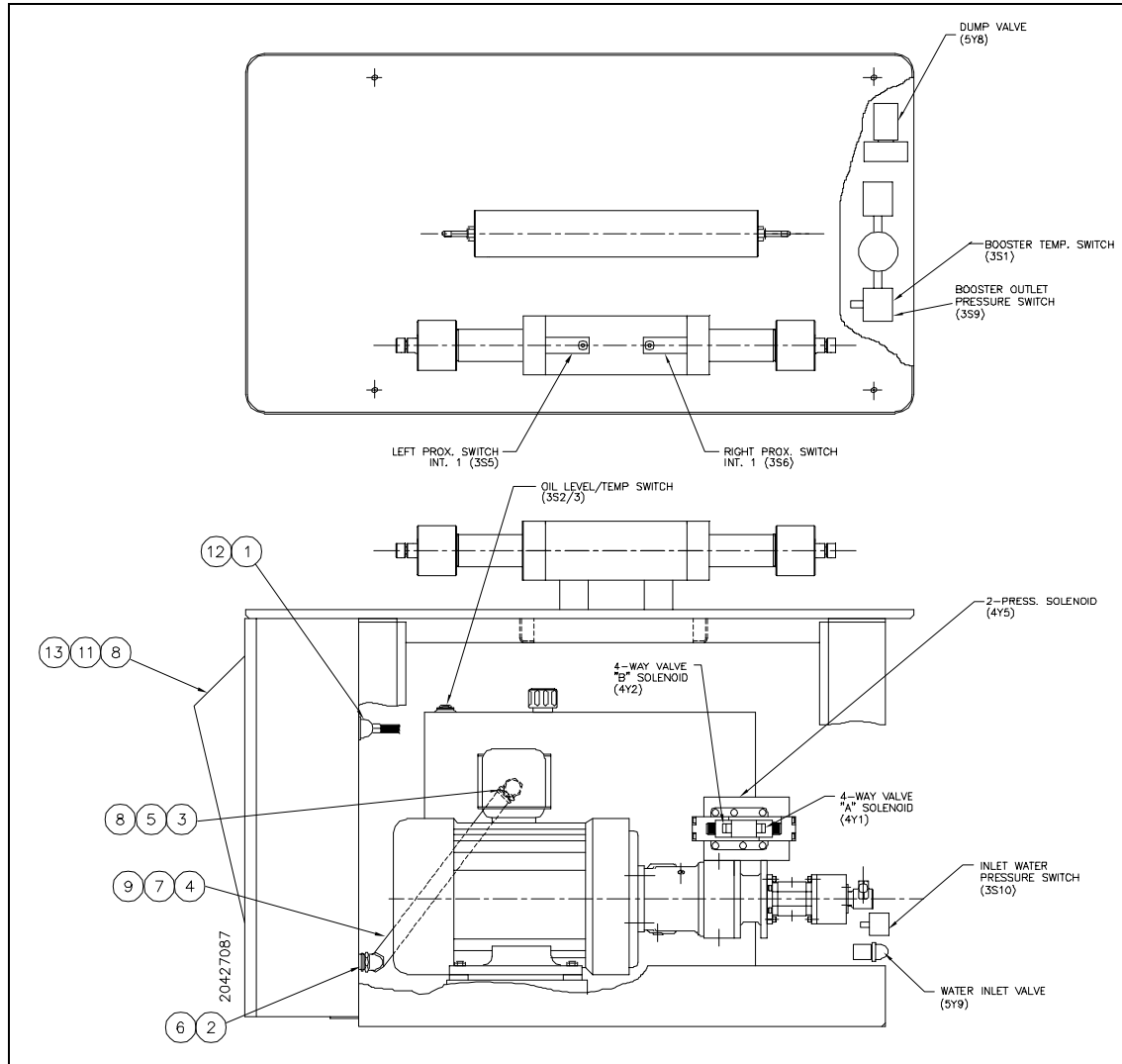


**Table 12-17**  
**Electrical Assembly, 230/50-60**  
**20434686**

<b>Item</b>	<b>Part Number</b>	<b>Description</b>	<b>Quantity</b>
1	05148531	Harness, Sensor/Solenoid Cable	1
2	20427069	Flexible Conduit Connector, 2.50	1
3	80080344	Terminal Lug, #10-250	9
4	20426246	Flexible Conduit, 2.50	42.0"
5	20426262	Flexible Conduit Connector, 2.50	1
6	20426254	Conduit Bushing, 2.50 x 2.50	1
8	05019799	Weld Cable	360.0"
9	20452905	Wire, #4, Green/Yellow	60.0"
11	05097464	Ring Terminal, #4, 0.312	1
12	95716890	Lock Washer, .50	4
13	10125912	Cable Tie, .87	5
14	20434678	Starter/Control Panel Configuration	1



Figure 12-17: Electrical Assembly, 230/50-60

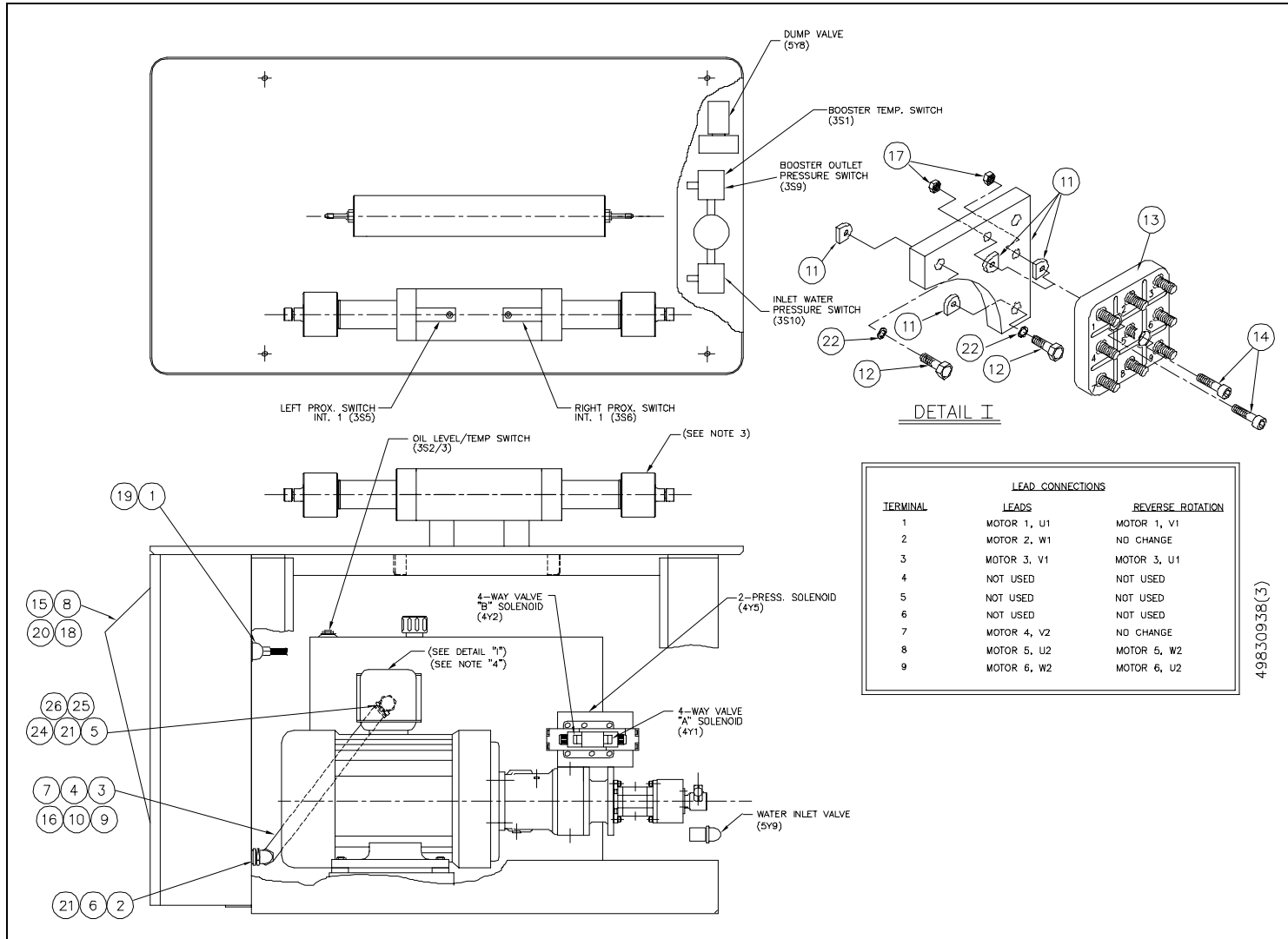




**Table 12-18**  
**Electrical Assembly, 380-415/50-60**  
**20424282**

Item	Part Number	Description	Quantity	Item	Part Number	Description	Quantity
1	05148531	Harness, Sensor/Solenoid Cable	1	13	05107321	Terminal Block	1
2	10098804	Flexible Conduit Connector, 2.0	1	14	95686721	Socket Head Screw, 1/4-20x1-3/4	2
3	05097464	Ring Terminal, #4	6	15	95423695	Hex Nut, 1/2-13	4
4	10098788	Flexible Conduit, 2.0	42.0"	17	05062344	Lock Nut, 1/4-20	2
5	10114932	Flexible Conduit Connector, 2.0	1	18	95716890	Lock Washer, .50	4
6	05147251	Conduit Bushing, 2.0 x 2.0	1	19	10125912	Cable Tie	5
7	05113923	Ring Terminal, #6	13	20	20424274	Starter/Control Panel Configuration	1
8	10069763	Flat Washer, .50	4	21	80078140	Conduit Bushing, 2.50 x 2.0	1
9	05014972	Weld Cable	360.0"	22	05107347	Conduit Locknut	1
10	49886583	Wire, #6, Green	60.0"	23	05112545	Lock Nut, 2.50	1
11	05107354	Adapter Block	1	24	10098937	Gasket Assembly	2
12	49887102	Hex Head Screw, 3/8-16x2-3/4	3				

Figure 12-18: Electrical Assembly, 380-415/50-60





**Table 12-19**  
**Controls Subassembly, 200-208, 230/50-60**  
**20415406**

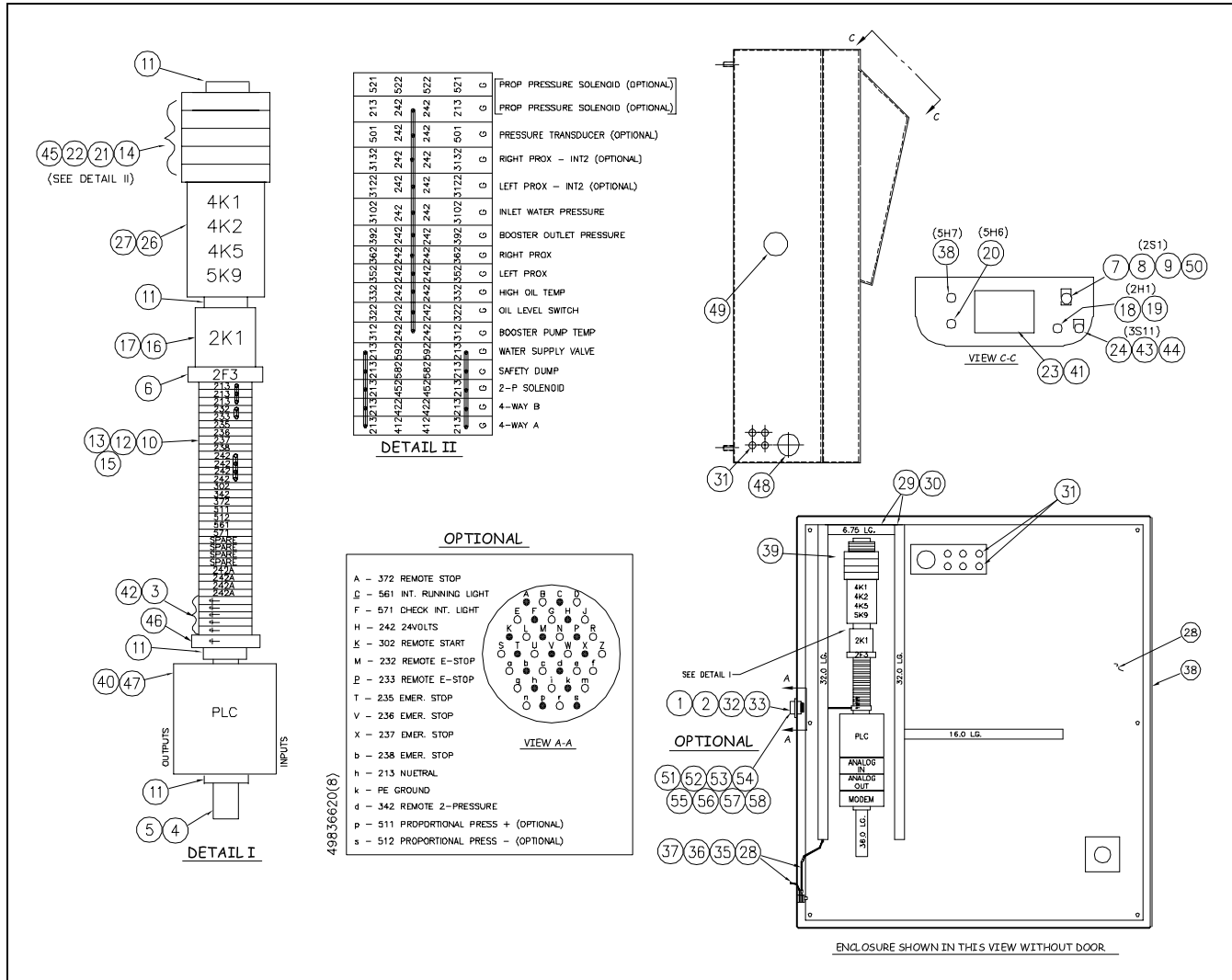
Item	Part Number	Description	Quantity	Item	Part Number	Description	Quantity
1	10176410	Wire, #16, Blue	3000.0"	18	49833395	Push Button Switch, Illuminated	1
2	10170165	Wire, #16/1 MM 2, Green/Yellow	190.0"	19	49833486	Lamp Socket Block, W/24V Bulb	1
3	05032420	Terminal Block, #24-#12	5	20	49833379	Pilot Light, Green, 24V	1
4	10103034	DIN Mounting Rail	36.0"	21	05113634	Terminal Block, 3 Level	17
5	10157667	Pan Head Screw, 10-32 x 3/4	12	22	05112826	Terminal Block Jumper, 10 Pole, 6 mm	1.6
6	20414961	Circuit Breaker, 10A	1	23	49830268	Cable, LRP Channel 1 To 550	1
7	49833403	Emergency Stop Switch, Push/Pull, Red	1	24	05140629	Legend Plate Holder, Black	1
8	20419143	Contact Block	3	25	20414500	Subplate	1
9	05049473	Legend Plate	1	26	10156859	I/O Rack, 4 Slot, 24V DC	1
10	05032438	Terminal Block, #22-#14	28	27	10146363	Single Point Output Module, DC 24	4
11	05032362	End Anchor, Terminal Block	4	28	10157659	Lock Washer, Star, 0.25	2
12	05032370	End Barrier	1	29	05021944	Wiring Duct, 1.00 x 2.00 x 6 Ft	1.2
13	05032388	Center Jumper, Terminal Block	1	30	10170132	Push Rivet, 0.187	28
14	05112818	Terminal Block Marker, 6 mm x 9 mm	0.7	31	49874191	Hole Seal, 0.50, Conduit Hole	10
15	05032412	Blank Markers, Terminal Blocks	0.4	32	05140926	Wire, #16, Orange	192.0"
16	10186104	Tube Base Relay, 24V DC, 3 PDT	1	33	10185395	Connector, Crimp Ferrule, #16	200
17	10196012	Relay Base, 11 Pin	1	34	80088800	Electrical Enclosure	1



**Table 12-19**  
**Controls Subassembly, 200-208, 230/50-60**  
**20415406**

Item	Part Number	Description	Quantity	Item	Part Number	Description	Quantity
35	10170157	Wire, #10/4 MM 2, Green/Yellow	36.0"	47	05144308	Programmable Controller	1
36	10094712	Ring Terminal, 14-10, 1/4	3	48	49874233	Hole Seal, 1.50, Conduit Hole	2
37	95416335	Hex Nut, 1/4-20	4	49	05061312	Hole Seal, 2.50, Conduit Hole	1
38	49833387	Pilot Light, Red, 24V	1	50	20416825	Illuminated Operator	1
39	10102242	Spiral Wrap, 0.38	12.0"	<b>Optional</b>			
40	05144316	Base Controller, 1500, 24V	1	51	10069888	Lock Washer, #6 x 0.031	4
41	05140157	Panelview Display, 550	1	52	05140967	Gasket, 37 Pin Box Receptacle	1
42	05115134	End Barrier, 3 Level Terminal Block	1	53	05140975	Cap, 37 Pin Connector	1
43	49833411	Selector Switch, Keyed, 2 Position	1	54	10069797	Flat Washer, #6 x 0.047	4
44	05114889	Legend Plate, Remote Control On/Off	1	55	10070951	Pan Head Screw, 6-32 x 3/4	4
45	05117601	End Barrier, 3 Level Terminal Block	1	56	10174431	Receptacle, 37 Contact, F	1
46	05115704	Terminal Block, #16-#6	1	57	10174712	Socket Contact, 16-22	37
				58	10069946	Hex Head Screw, #6-32	4

Figure 12-19: Controls Subassembly, 200-208, 230/50-60





**Table 12-20**  
**Controls Subassembly, 380-415/50-60**  
**80077845**

Item	Part Number	Description	Quantity	Item	Part Number	Description	Quantity
1	10176410	Wire, #16, Blue	3000.0"	18	49833395	Push Button Switch, Illuminated	1
2	10170165	Wire, #16/1 MM 2, Green/Yellow	190.0"	19	49833486	Lamp Socket Block, W/24V Bulb	1
3	05032420	Terminal Block, #24-#12	5	20	49833379	Pilot Light, Green, 24V	1
4	10103034	DIN Mounting Rail	36.0"	21	05113634	Terminal Block, 3 Level	17
5	10157667	Pan Head Screw, 10-32 x 3/4	12	22	05112826	Terminal Block Jumper, 10 Pole, 6 mm	1.6
6	49839335	Circuit Breaker, 6A	1	23	49830268	Cable, LRP Channel 1 To 550	1
7	20416802	Emergency Stop Switch	1	24	05140629	Legend Plate Holder, Black	1
8	20419143	Contact Block	3	25	20414500	Subplate	1
9	05049473	Legend Plate	1	26	10156859	I/O Rack, 4 Slot, 24V DC	1
10	05032438	Terminal Block, #22-#14	28	27	10146363	Single Point Output Module, DC 24	4
11	05032362	End Anchor, Terminal Block	4	28	10157659	Lock Washer, Star, 0.25	2
12	05032370	End Barrier	1	29	05021944	Wiring Duct, 1.00 x 2.00 x 6 Ft	1.2
13	05032388	Center Jumper, Terminal Block	1	30	10170132	Push Rivet, 0.187	28
14	05112818	Terminal Block Marker, 6 mm x 9 mm	0.7	31	49874191	Hole Seal, 0.50, Conduit Hole	10
15	05032412	Blank Markers, Terminal Blocks	0.4	32	05140926	Wire, #16, Orange	192.0"
16	10186104	Tube Base Relay, 24V DC, 3 PDT	1	33	10185395	Connector, Crimp Ferrule, #16	200
17	10196012	Relay Base, 11 Pin	1	34	80088800	Electrical Enclosure	1

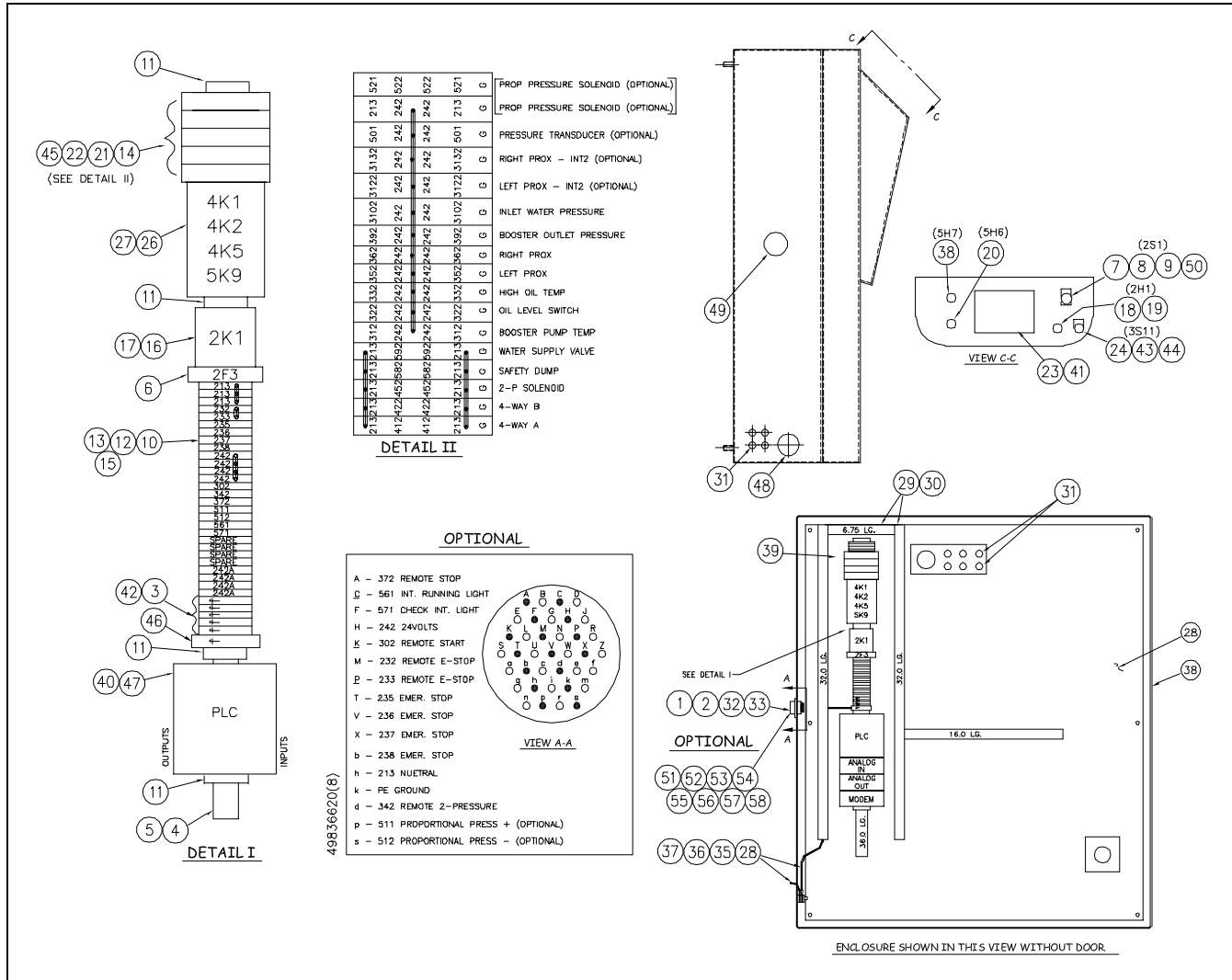


**Table 12-20**  
**Controls Subassembly, 380-415/50-60**  
**80077845**

Item	Part Number	Description	Quantity	Item	Part Number	Description	Quantity
35	10170157	Wire, #10/4 MM 2, Green/Yellow	36.0"	47	05144308	Programmable Controller	1
36	10094712	Ring Terminal, 14-10, 1/4	3	48	49874233	Hole Seal, 1.50, Conduit Hole	2
37	95416335	Hex Nut, 1/4-20	4	49	05061312	Hole Seal, 2.50, Conduit Hole	1
38	49833387	Pilot Light, Red, 24V	1	50	20416825	Illuminated Operator	1
39	10102242	Spiral Wrap, 0.38	12.0"	<b>Optional</b>			
40	05144316	Base Controller, 1500, 24V	1	51	10069888	Lock Washer, #6 x 0.031	4
41	05140157	Panelview Display, 550	1	52	05140967	Gasket, 37 Pin Box Receptacle	1
42	05115134	End Barrier, 3 Level Terminal Block	1	53	05140975	Cap, 37 Pin Connector	1
43	49833411	Selector Switch, Keyed, 2 Position	1	54	10069797	Flat Washer, #6 x 0.047	4
44	05114889	Legend Plate, Remote Control On/Off	1	55	10070951	Pan Head Screw, 6-32 x 3/4	4
45	05117601	End Barrier, 3 Level Terminal Block	1	56	10174431	Receptacle, 37 Contact, F	1
46	05115704	Terminal Block, #16-#6	1	57	10174712	Socket Contact, 16-22	37
				58	10069946	Hex Head Screw, #6-32	4



Figure 12-20: Controls Subassembly, 380-415/50-60

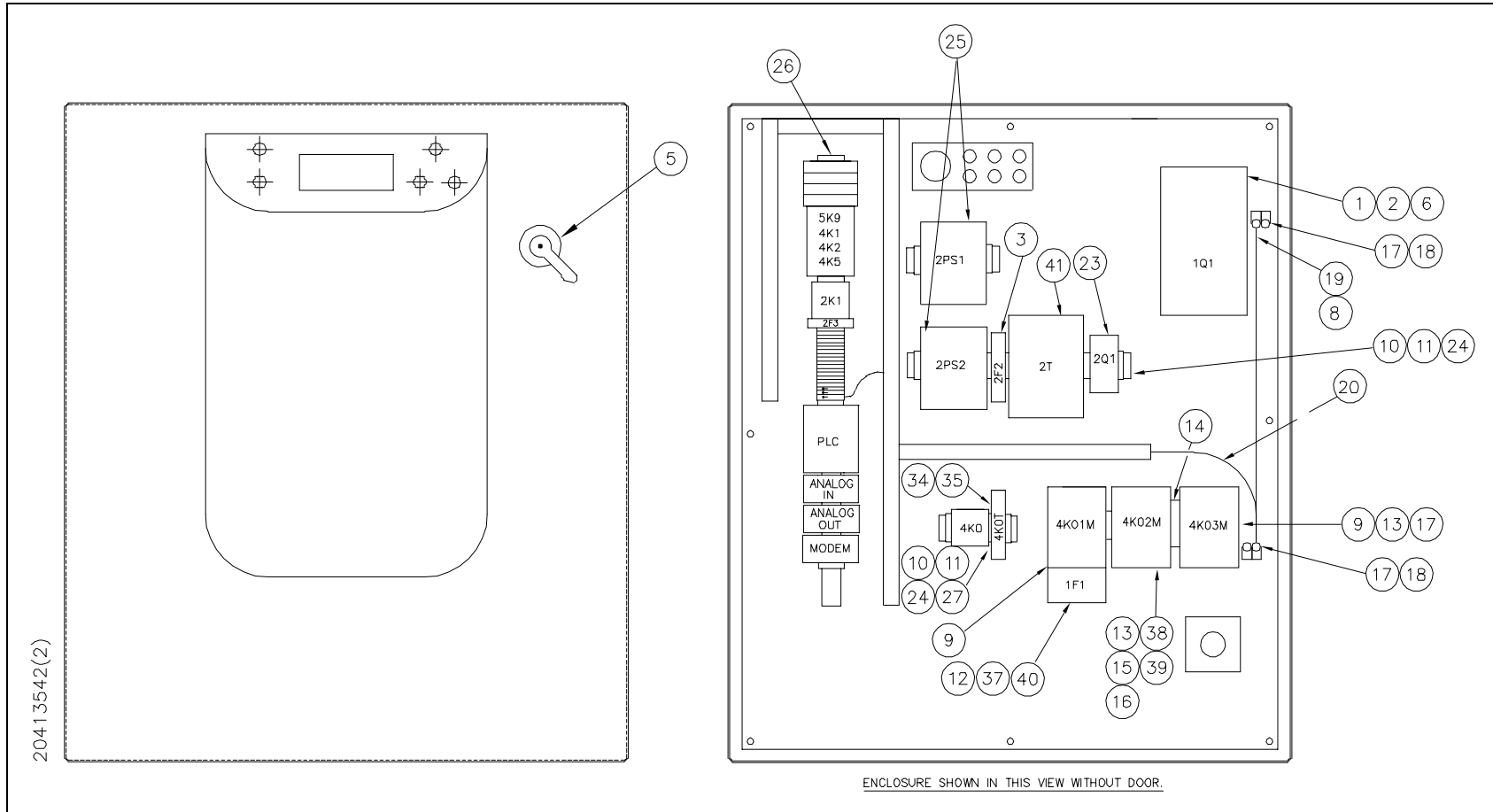




**Table 12-21**  
**Control Panel Configuration, 200-208/50-60**  
**20413542**

Item	Part Number	Description	Quantity	Item	Part Number	Description	Quantity
1	20413534	Circuit Breaker, 350A	1	20	10170157	Wire, #10/4 MM 2, Green/Yellow	42.0"
2	05081955	Socket Head Screw, 8-32 x 2	4	21	05019898	Wire, #14, Black	90.0"
3	20414747	Circuit Breaker, 5A	1	22	05019617	Connector, Crimp Ferrule, #14/2.5 MM	12
4	20467008	Terminal Lug	6	23	05140686	Circuit Breaker, 600V, 3 Phase	1
5	80083488	Rotary Drive	1	24	05032362	End Anchor, Terminal Block	9
6	80083496	Terminal Cover	2	25	05115183	Power Supply, 24V DC	2
7	20451607	Weld Cable	216.0"	26	20415406	Controls Subassembly, 200-208V	1
8	05071048	Connector, Crimp Ferrule	18	27	49833429	Timing Relay, 1.5-30 Second	1
9	20413583	Contact, Non-Reversing, 180A, 24V DC	2	28	10185395	Connector, Crimp Ferrule, #16	8
10	10157667	Pan Head Screw, 10-32 x 3/4	24	29	10176410	Wire, #16, Blue	48.0"
11	10103034	DIN Mounting Rail	15.0"	30	10170165	Wire, #16/1 MM 2, Green/Yellow	48.0"
12	80083603	Overload Relay, 20-180A	1	34	10098226	Tube Base Relay, 24V DC	1
13	80083660	Auxiliary Contact, 1 NO/1 NC	2	35	10098242	Screw Terminal, Tube Base Socket	1
14	80083595	Mechanical Interlock, Contactor	1	36	10181550	Wire, #16, Red	100.0"
15	20413575	Contact, Non-Reversing, 110A, 24V DC	1	37	80083553	Lug Kit, D180 Contactor, AB	2
16	05139498	Wire, #3, Green	3.0"	38	80083561	Lug Kit, D110 Contactor, AB	1
17	05095609	Ground Lug, -#6-#350	2	39	80083587	Terminal Cover, 100-D110, AB	1
18	95423620	Hex Head Screw, 5/16-18 x 3/4	2	40	80083579	Terminal Cover, 100-D180, AB	2
19	05139498	Wire, #3, Green	24.0"	41	49836562	Transformer, Controller	1

Figure 12-21: Control Panel Configuration, 200-208/50-60

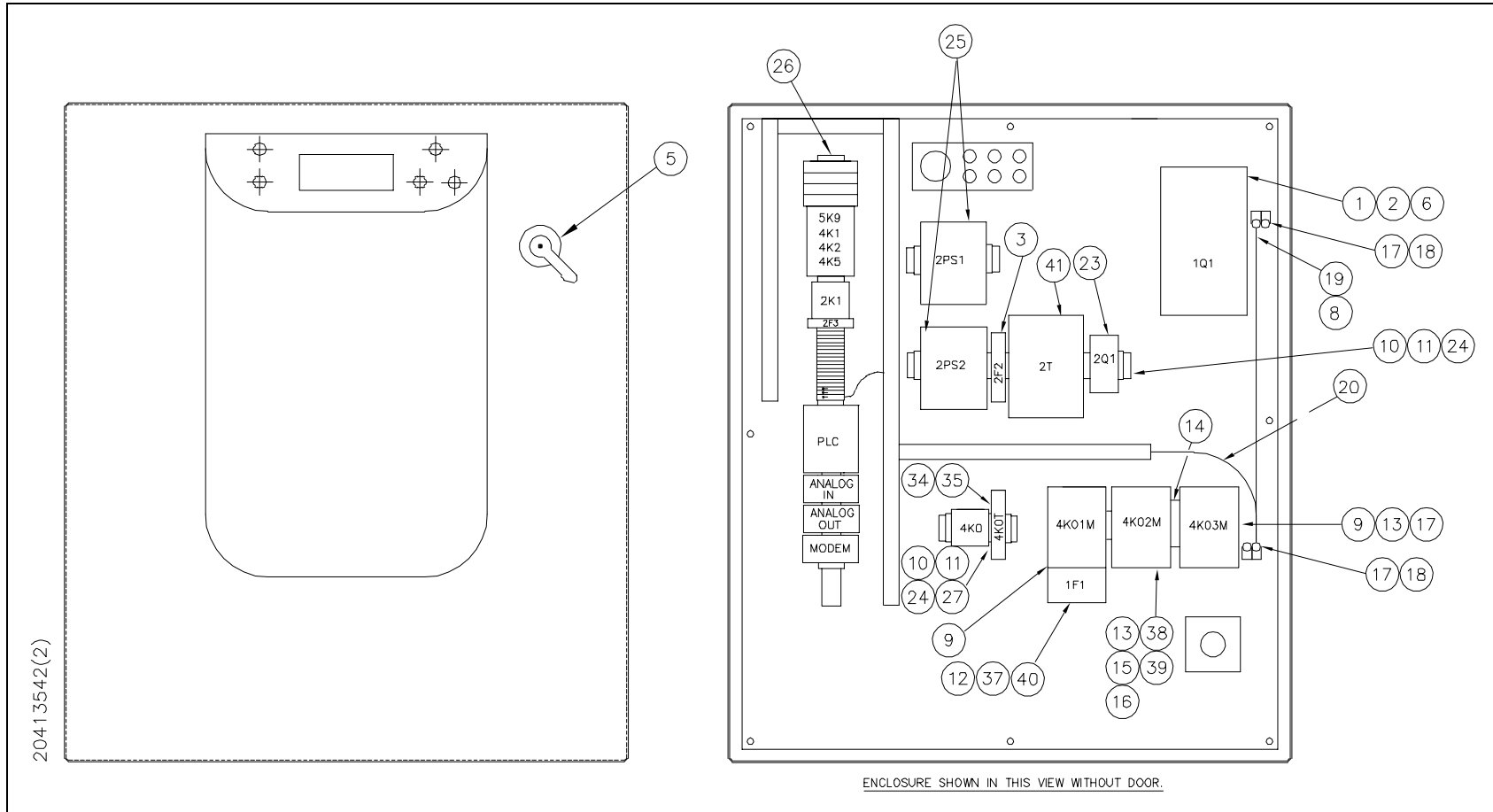




**Table 12-22**  
**Control Panel Configuration, 230/50-60**  
**20434678**

Item	Part Number	Description	Quantity	Item	Part Number	Description	Quantity
1	20434644	Circuit Breaker, 300A	1	20	10170157	Wire, #10/4 MM 2, Green/Yellow	42.0"
2	05081955	Socket Head Screw, 8-32 x 2	4	21	05019898	Wire, #14, Black	90.0"
3	20414747	Circuit Breaker, 5A	1	22	05019617	Connector, Crimp Ferrule, #14/2.5 MM	12
5	80083488	Rotary Drive	1	23	05140686	Circuit Breaker, 600V, 3 Phase	1
6	80083496	Terminal Cover	2	24	05032362	End Anchor, Terminal Block	9
7	05019799	Weld Cable	216.0"	25	05115183	Power Supply, 24V DC	2
8	05071030	Connector, Crimp Ferrule	18	26	20415406	Controls Subassembly, 200-208V	1
9	20434660	Contact, Non-Reversing, 140A, 24V DC	2	27	49833429	Timing Relay, 1.5-30 Second	1
10	10157667	Pan Head Screw, 10-32 x 3/4	24	28	10185395	Connector, Crimp Ferrule, #16	8
11	10103034	DIN Mounting Rail	15.0"	29	10176410	Wire, #16, Blue	48.0"
12	80083603	Overload Relay, 20-180A	1	30	10170165	Wire, #16/1 MM 2, Green/Yellow	48.0"
13	80083660	Auxiliary Contact, 1 NO/1 NC	2	34	10098226	Tube Base Relay, 24V DC	1
14	80083595	Mechanical Interlock, Contactor	1	35	10098242	Screw Terminal, Tube Base Socket	1
15	20434652	Contact, Non-Reversing, 95A, 24V DC	1	36	10181550	Wire, #16, Red	100.0"
16	05107248	Crimp Ferrule	3	37	80083553	Lug Kit, D180 Contactor, AB	2
17	05095609	Ground Lug, -#6-#350	2	38	80083561	Lug Kit, D110 Contactor, AB	1
18	95423620	Hex Head Screw, 5/16-18 x 3/4	2	39	80083587	Terminal Cover, 100-D110, AB	1
19	20452905	Wire, #4, Green/Yellow	24.0"	40	80083579	Terminal Cover, 100-D180, AB	2
				41	49836562	Transformer, Controller	1

Figure 12-22: Control Panel Configuration, 230/50-60

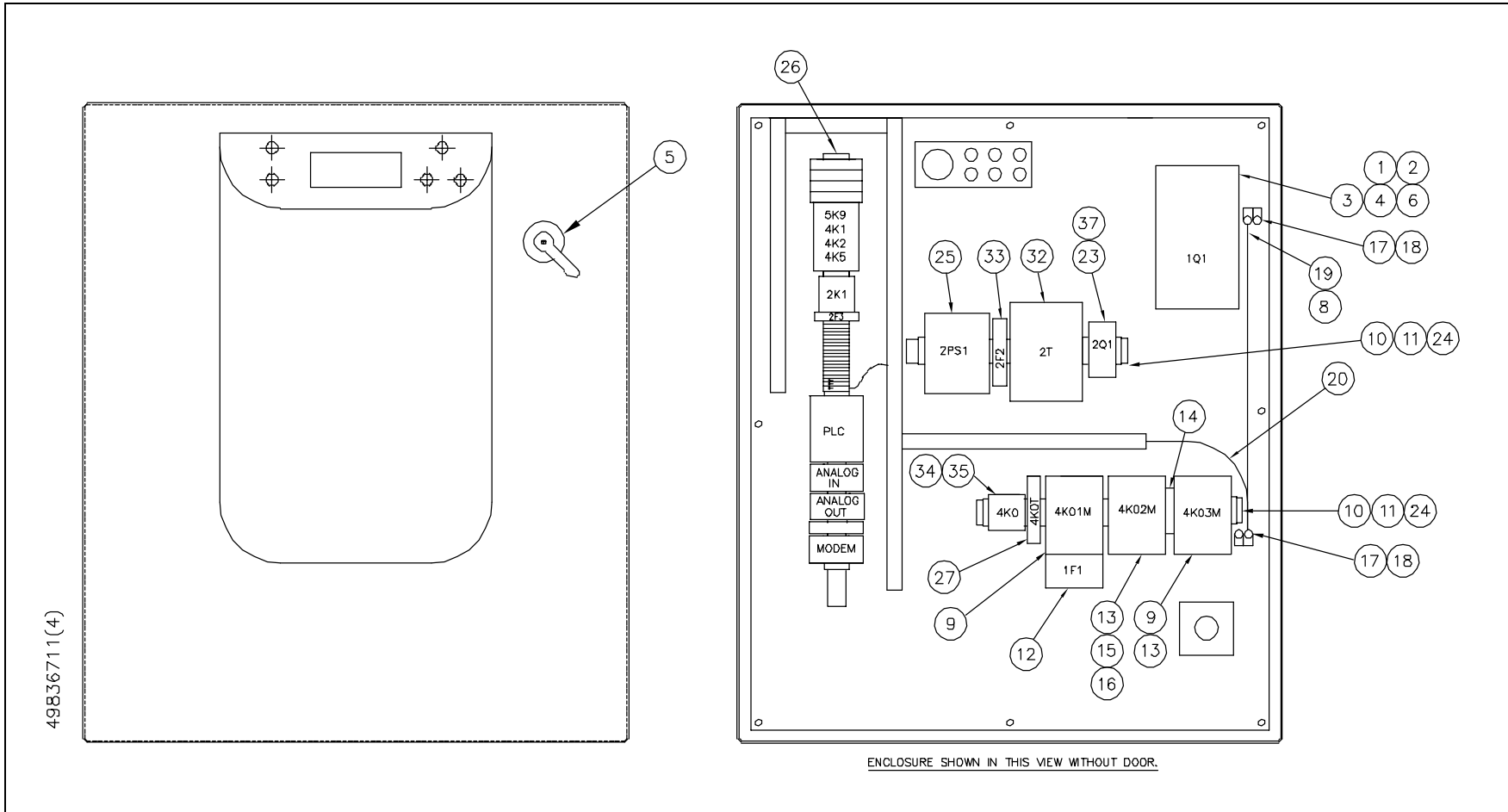




**Table 12-23**  
**Control Panel Configuration, 380-415/50-60**  
**20424274**

Item	Part Number	Description	Quantity	Item	Part Number	Description	Quantity
1	80077894	Circuit Breaker, 175A	1	20	10170157	Wire, #10/4 MM 2, Green/Yellow	42.0"
2	05031620	Socket Head Screw, 10-32 x 1-3/4	4	21	05019898	Wire, #14, Black	90.0"
3	20465033	Terminal Lug	6	22	05019617	Connector, Crimp Ferrule, #14/2.5 MM	12
5	80080377	Rotary Drive	1	23	05140686	Circuit Breaker, 600V	1
6	80080385	Terminal Breaker	2	24	05032362	End Anchor, Terminal Block	7
7	0514972	Weld Cable	144.0"	25	05140876	Power Supply, 24V DC	1
8	05149778	Connector, Crimp Pin	21	26	80077845	Controls Subassembly	1
9	49839814	Contact, Non-Reversing, 85A, 230V AC	2	27	49833429	Timing Relay, 1.5-30 Second	1
10	10157667	Pan Head Screw, 10-32 x 3/4	8	28	10185395	Connector, Crimp Ferrule, #16	8
11	10103034	DIN Mounting Rail	29.0"	29	10176410	Wire, #16, Blue	48.0"
12	05111448	Overload Relay, 26-85A	1	30	10170165	Wire, #16/1 MM 2, Green/Yellow	48.0"
14	05111471	Interlock, Contactor	1	32	49836562	Transformer, Controller	1
15	49836950	Contact, Non-Reversing, 60A, 230V AC	1	33	80074131	Circuit Breaker	1
16	49830367	Y-D Wiring Kit	1	34	10098226	Tube Base Relay, 24V DC	1
17	05095609	Ground Lug, -#6-#350	2	35	10098242	Screw Terminal, Tube Base Socket	1
18	95423620	Hex Head Screw, 5/16-18 x 3/4	2	36	10181550	Wire, #16, Red	100.0"
19	49886583	Wire, #6, Green	24.0"				

Figure 12-23: Control Panel Configuration, 380-415/50-60





**Table 12-24**  
**Proportional Pressure Control**  
**80075732**

---

<b>Item</b>	<b>Part Number</b>	<b>Description</b>	<b>Quantity</b>
1	80071087	Hydraulic Solenoid Valve, 24V	1
2	49867104	Cable, #18, 4 Conductor	96.0"
3	10067205	Cable Connector, .50	1
4	10176410	Wire, #16, Blue	100.0"
5	10185395	Connector, Crimp Ferrule, #16	10
6	0514647725	EEPROM	1
7	80088560	End Cap, 4-Way Modulating Valve	1



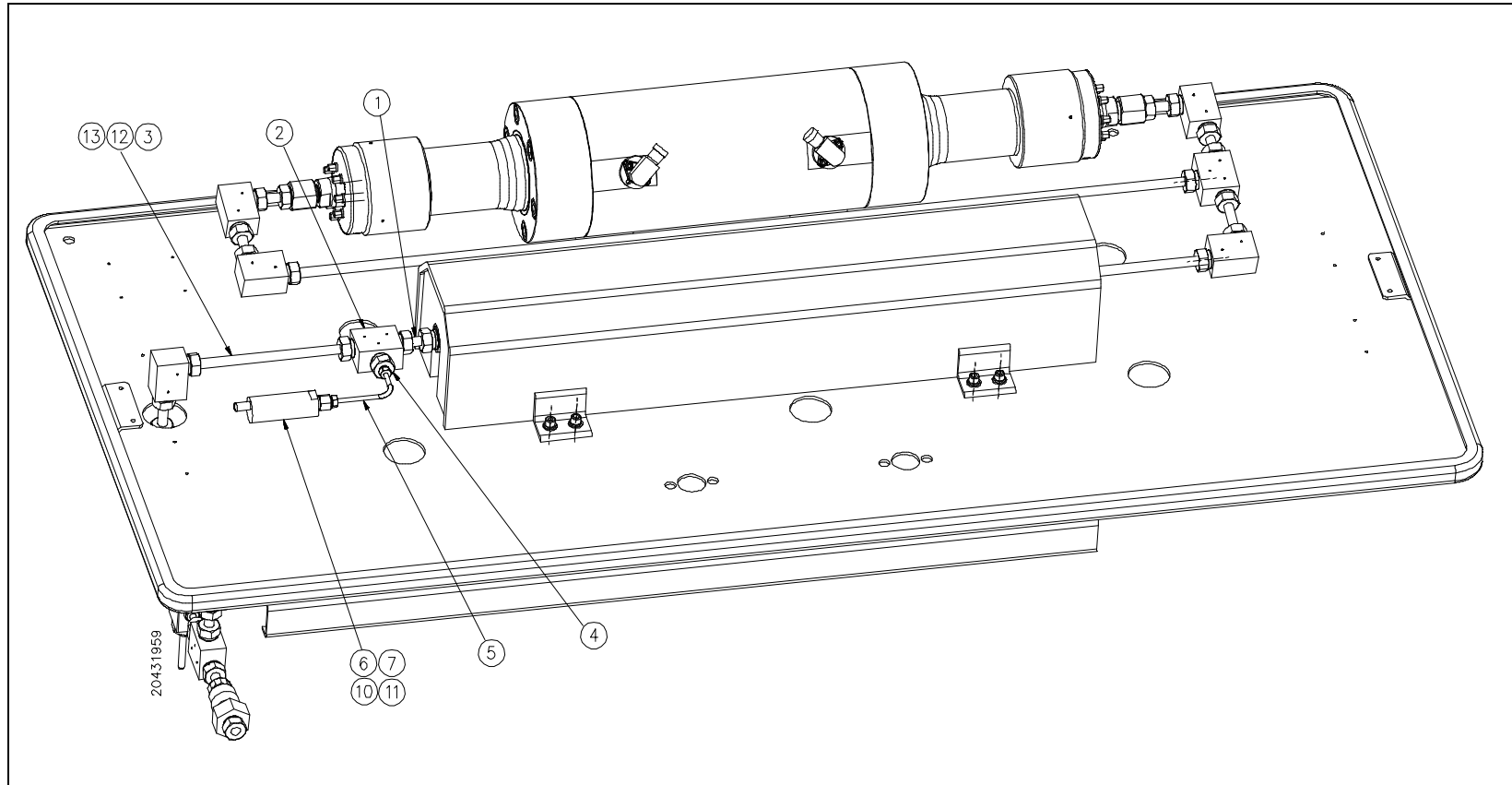




**Table 12-25**  
**High Pressure Transducer**  
**20431959**

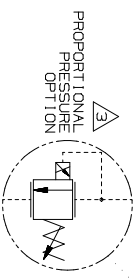
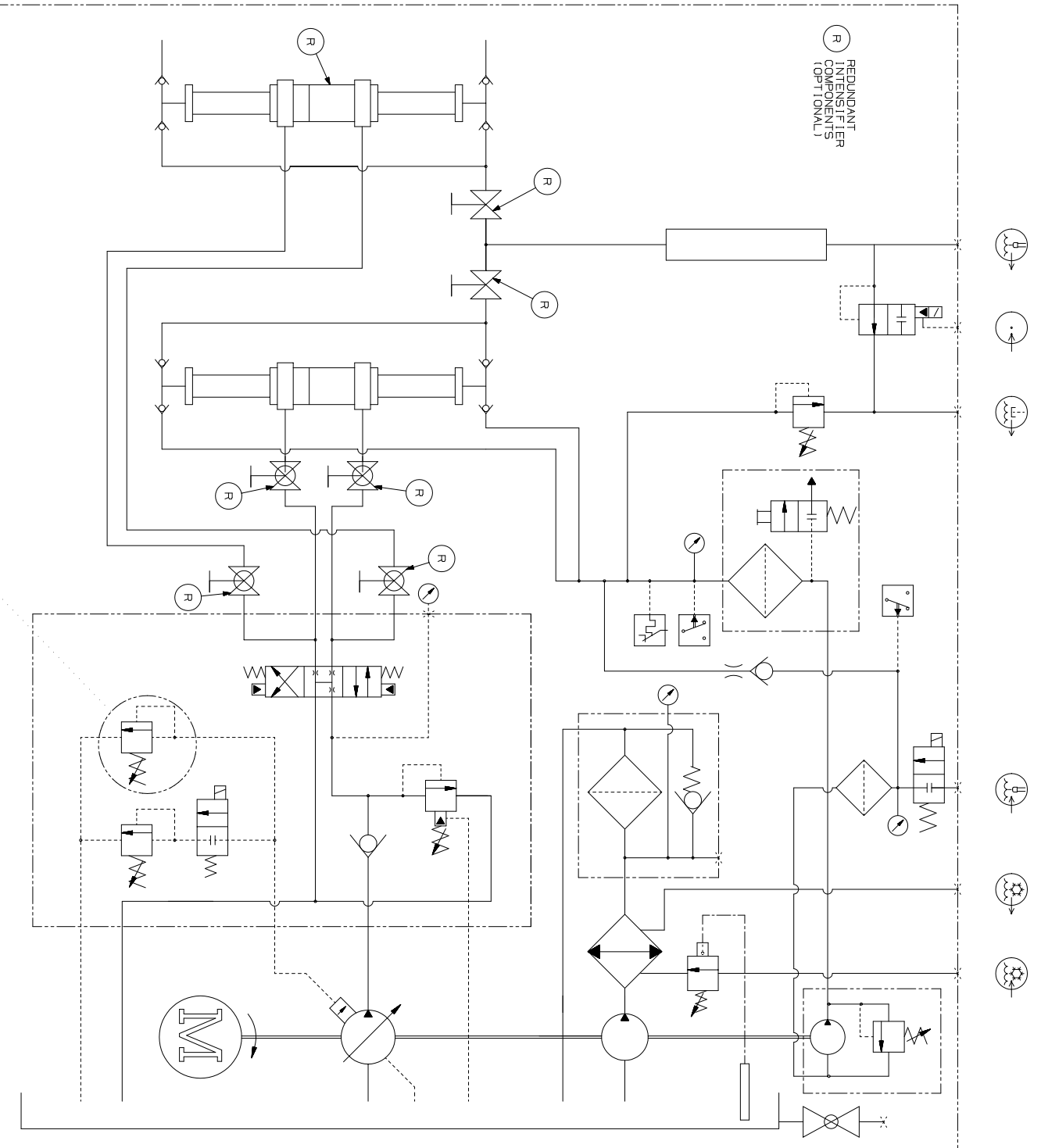
<b>Item</b>	<b>Part Number</b>	<b>Description</b>	<b>Quantity</b>
1	10069326	HP Tube, .56 x .188 x 4.0	1
2	10079465	HP Tee, .56	1
3	20412627	HP Tube, .56 x .188 x 11.50	1
4	10079580	HP Bushing, .56 x .25	1
5	05071782	HP Tube, Bent, .25 x .83	1
6	49838478	Pressure Transducer, 0-75,000 psi	1
7	10067205	Cable Connector, .50	1
8	10176410	Wire, #16, Blue	100.0"
9	10185395	Connector, Crimp Ferrule, #16	10
10	10078459	HP Gland, .25	1
11	10078426	HP Collar, .25	1
12	05086905	Flexible Conduit, .63	12.0"
13	05131347	Ferrule, .50	2
14	0514647725	EEPROM	1
15	0514192420	Flashcard	1

Figure 12-25: High Pressure Transducer



NO.	REVISION	DATE	APPROVED
1	REVISED PER JDS	5/13/03	BR
2	REVISED LP WATER CIRCUIT	7/27/04	J/27/04
3	ADDED PROPORTIONAL PRESSURE OPTION REF EPR REV03288	10/24/05	J/2/05

FIG. NO. 49835622D SH. 1 OF 3



Copyright © 2003  
KMT Waterjet Systems  
All Rights Reserved

**PROPRIETARY NOTICE**

This document contains confidential and trade secret information, is the property of KMT Waterjet Systems, and its use, reproduction, or distribution is restricted to those individuals and entities specifically authorized in writing by KMT Waterjet Systems. It will (1) not be used for any other purpose, (2) not be copied, (3) not be disclosed to others without the consent of KMT Waterjet Systems, and (4) upon demand return the document, all copies thereof, and all material copied therefrom.

**STANDARD TOLERANCES:**  
UNLESS OTHERWISE SPECIFIED:  
DIMENSIONS IN INCHES [mm]  
COMMON CENTERLINE  
DIMENSIONS TO DIMS  
AND CORNERS 0.015  
STANDARD SURFACE FINISH: 6.3  
XXX = ± 0.015  
XXX = ± 0.063  
ANGLE = 45°

**CD&T TO ASME Y14.5M 1994**

REF. NO. 05079510  
DRAWN BY: A. JOSE  
CHECKED BY: A. JOSE  
DATE APPROVED: 5/02

MATERIAL: B1, Runtble  
FINISH: H, Shields  
DIMENSIONS: H, Shields  
DATE: 5/22

**KMT Waterjet Systems**

**SCHEMATIC—SYSTEM**  
SLV/SLV REDUNDANT

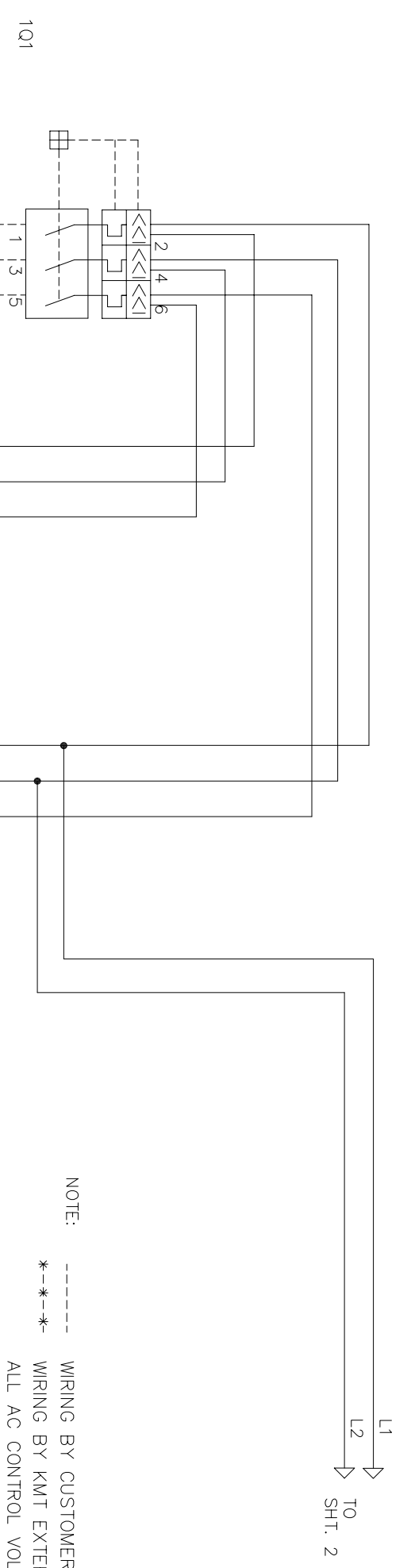
FIG. NO. 49835622D  
SCALE: —  
TITLE BLOCK REVISION: 1

SHEET 1 OF 1

NOT ASSURED

REV. 1	REV. 2	REV. 3	REV. 4
DATE	DATE	DATE	DATE
DESCRIPTION	DESCRIPTION	DESCRIPTION	DESCRIPTION
NO.	NO.	NO.	NO.

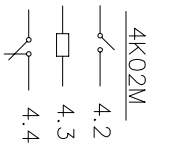
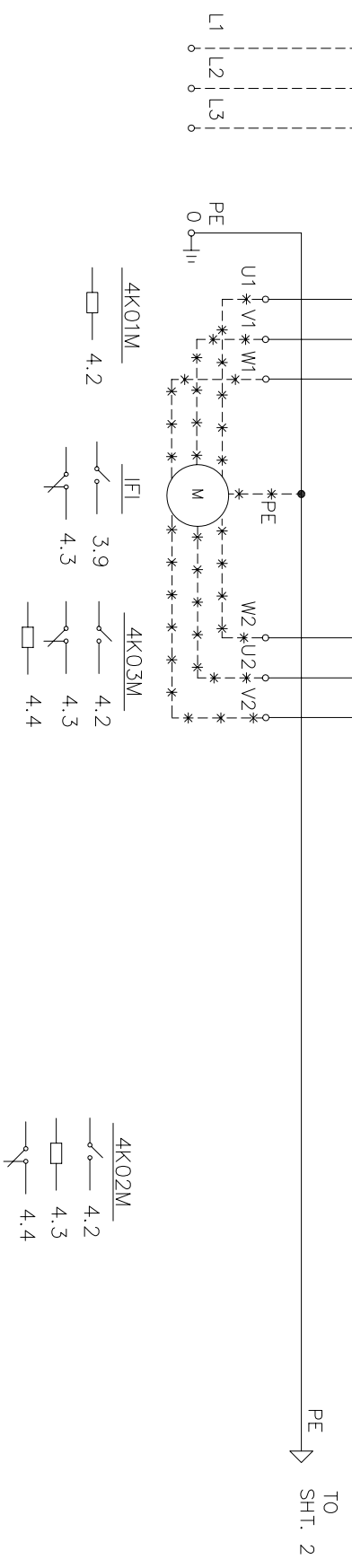
DWG. NO. 20414755D  
SHEET 1 OF 4



NOTE: -----  
 \*-\*-\* WIRING BY CUSTOMER IN ACCORDANCE WITH LOCAL REGULATIONS.  
 \*-\*-\* WIRING BY KMT EXTERNAL TO PANEL  
 ALL AC CONTROL VOLTAGE WIRES MUST BE RED IN COLOR

MOTOR FLA

HP \ VOLTAGE	200	208	230	400	415	460
30	92	88	80	46	44	40
50	150	143	130	75	72	65
100	285	273	248	143	138	124



Copyright ©2003  
 KMT Waterjet Systems  
 All Rights Reserved

PROPRIETARY NOTICE  
 This document contains confidential and trade secret information, is the property of KMT Waterjet Systems, and is not to be distributed, copied, or otherwise used without the written permission of KMT Waterjet Systems. It is to be used in confidence and agrees that, except as authorized in writing by KMT Waterjet Systems, it will not use the trade secret information therein; (2) not copy the document; (3) not disclose to others either the document or the information contained therein; (4) not use the information for any purpose other than that intended by KMT Waterjet Systems upon demand return the document, all copies thereof, and all material copied therefrom.

STANDARD TOLERANCES  
 UNLESS OTHERWISE NOTED:  
 ALL DIMENSIONS IN INCHES [mm]  
 COMMON CENTRAL LINE  
 COAXIAL TO .005  
 BREAK SHARP EDGES  
 AND CORNERS .015  
 SURFACE FINISH - .7  
 HEAT TREAT -  
 X.XX = ±.003  
 X.XXX = ±.015  
 X.XXX = ±.020  
 ANGLE = .42

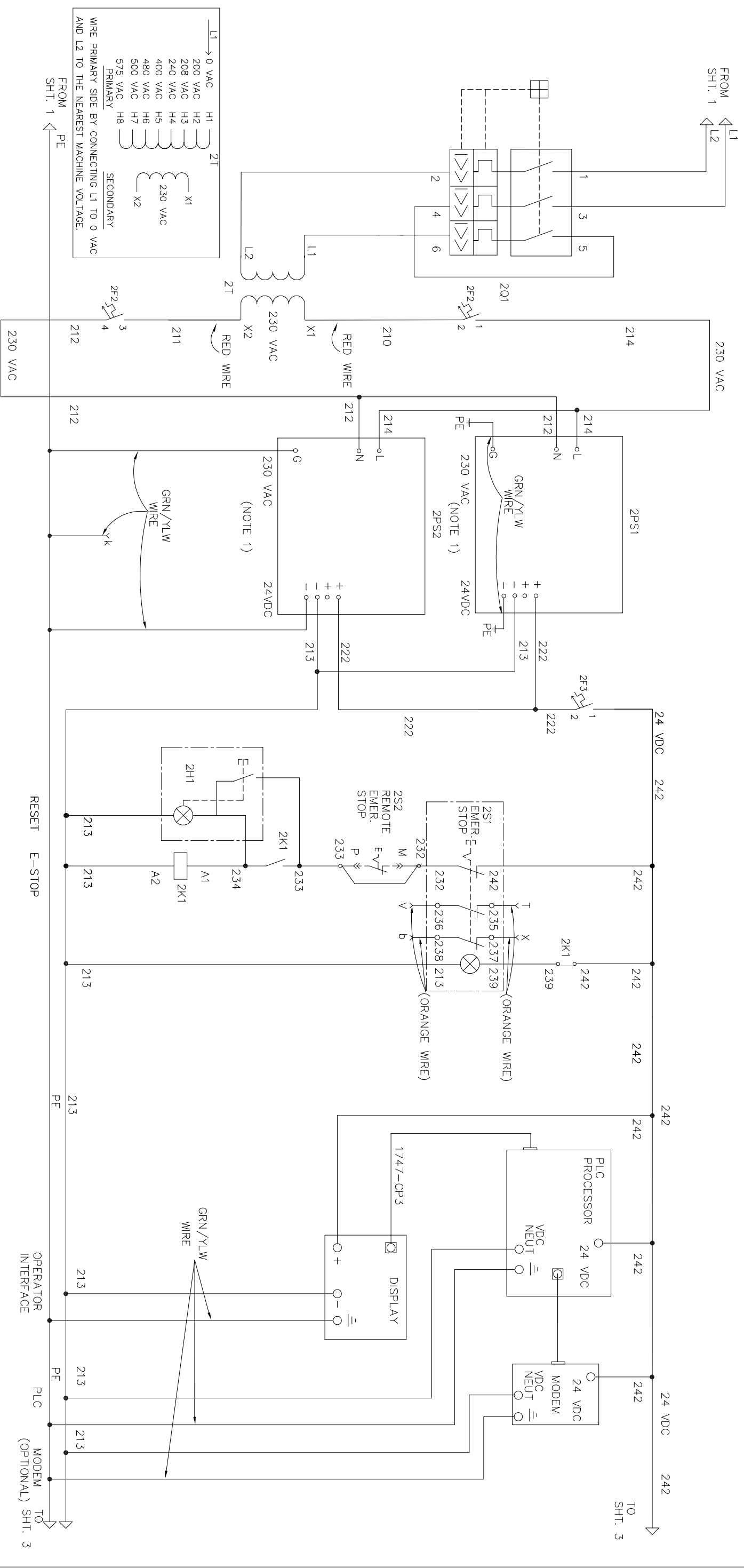
GD&T TO ASME Y14.5M 1994  
 REF. DWG 49836604D  
 DRAWN BY & DATE B RUMBEL 7/7/02  
 CHECKED BY DPN 7/02  
 ENG. APPROVAL & DATE  
 SCALE: -  
 THIRD ANGLE PROJECTION  
 TITLE BLOCK REVISION: 1  
 SHEET 1 OF 5

**KMT Waterjet Systems**

SCHEM - ELEC SLV, Y - D, 24V  
 200 - 208, 100HP  
 DWG. NO. 20414755D  
 REV. 4

ACAD

REVISIONS			
NO	DESCRIPTION	DATE	APPROVED
1	CHANGED E-STOP REF. FOR REV02797	10/22/04	JD/2/04
2	REVISED FOR REV02797	3/8/04	3/8/04
3	REF. FOR REV02997	3/8/04	3/8/04



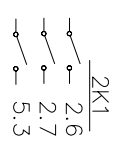
NOTE:

1. INSURE SELECTOR SWITCH ON POWER SUPPLIES ARE IN PARALLEL POSITION.

-----  
 WIRING BY CUSTOMER IN ACCORDANCE WITH LOCAL REGULATIONS.

\*-\*-\*-\*  
 WIRING BY KMT EXTERNAL TO PANEL

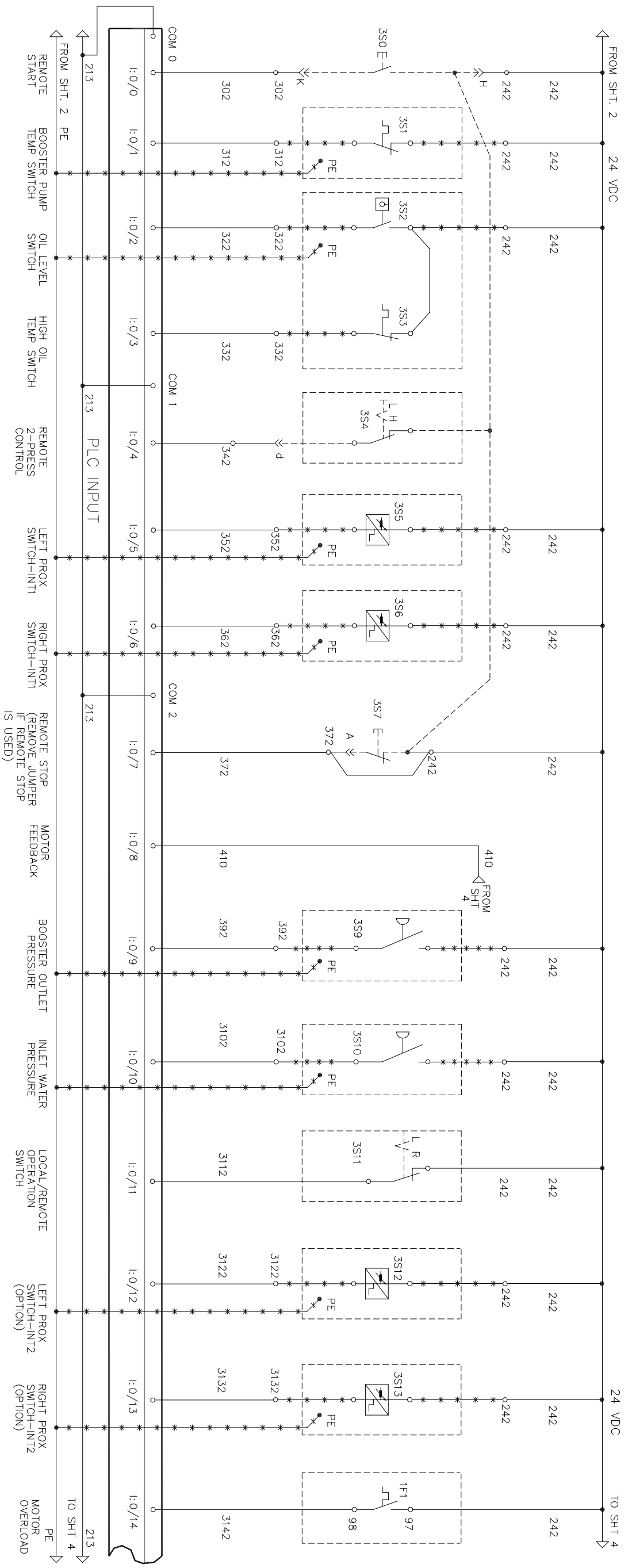
ALL AC CONTROL VOLTAGE WIRES MUST BE RED IN COLOR



Copyright ©2003 KMT Waterjet Systems All Rights Reserved		PROPRIETARY NOTICE		STANDARD TOLERANCES UNLESS OTHERWISE NOTED: ALL DIMENSIONS IN INCHES [mm]		GD&T TO ASME Y14.5M 1994 REF. DIM 49836040		DATE 7/10/02 BY RUMBEL		TITLE SCHEM - ELEC SLV, Y - D, 24V 200 - 208, 100HP			
WARNING ! The export or reexport of this drawing is subject to U.S. Export Administration regulations and other applicable governmental restrictions or regulations.		This document contains confidential and trade secret information, is the property of KMT Waterjet Systems, and is loaned and retention of the document accepts the document in confidence and agrees that, except as authorized in writing by KMT Waterjet Systems, it will not use the information contained herein for any other purpose. (3) not disclose to others either the document or the trade secret information therein; (2) not copy the document; and upon demand return the document, all copies thereof, and all material copied therefrom.		HEAT TREAT - SURFACE FINISH - X.XX = ±.003 X.XX = ±.015 X.XX = ±.02		DRAWN BY & DATE B RUMBEL CHECKED BY 7/10/02		DATE APPROVAL & DATE		SCALE: THIRD ANGLE PROJECTION		TITLE BLOCK REVISION: 1	
NEXT ASSEMBLY		---		---		---		---		20414755D		SHEET 2 OF 5	

NO.	DESCRIPTION	DATE	APPROVED

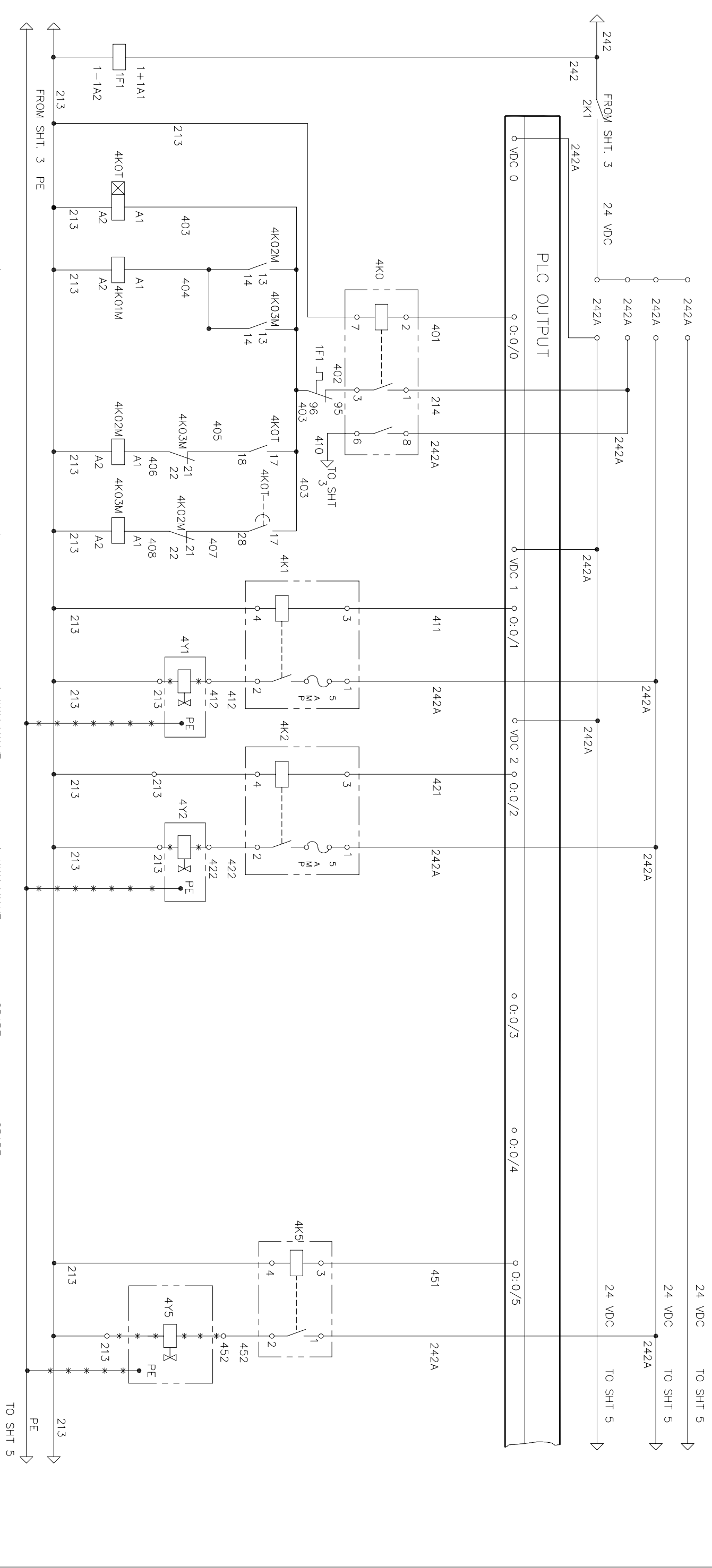
DWG. NO. 20414755D  
 SHEET 3 OF 4



-----  
 WIRING BY CUSTOMER IN ACCORDANCE WITH LOCAL REGULATIONS  
 \*---\* WIRING BY KMT EXTERNAL TO PANEL  
 ALL AC CONTROL VOLTAGE WIRES MUST BE RED IN COLOR

Copyright ©2003 KMT Waterjet Systems All Rights Reserved		PROPRIETARY NOTICE		STANDARD TOLERANCES		GD&T TO ASME Y14.5M 1994					
<p>WARNING !</p> <p>The export or reexport of this document is prohibited by U.S. Export Administration regulations and other applicable governmental restrictions or regulations.</p>		<p>This document contains confidential and trade secret information, is the property of KMT Waterjet Systems, and is loaned and retention of the document is subject to the terms and conditions of the document. It is not to be used, copied, or disseminated in any way without the written permission of KMT Waterjet Systems. (1) not use the information contained herein for any other purpose; (2) not copy, reproduce, or disseminate the information contained herein; (3) not disclose to others either the document or the information contained herein; (4) upon completion of the need to retain the document, return the document to KMT Waterjet Systems and all material copied therefrom.</p>		<p>UNLESS OTHERWISE NOTED:          ALL DIMENSIONS IN INCHES [mm]          BREAK SHARP EDGES AND CORNERS 015          SURFACE FINISH -          X.X = ±.003          X.XX = ±.015          X.XXX = ±.005          ANGLE = .42°</p>		<p>HARDNESS -          DRG. APPROVAL &amp; DATE          7/02</p>		<p>SCALE: -          THIRD ANGLE PROJECTION</p>		<p>DRG. NO. 20414755D          SHEET 3 OF 5</p>	
<p>Copyright ©2003 KMT Waterjet Systems All Rights Reserved</p>		<p>UNLESS OTHERWISE NOTED:          ALL DIMENSIONS IN INCHES [mm]          BREAK SHARP EDGES AND CORNERS 015          SURFACE FINISH -          X.X = ±.003          X.XX = ±.015          X.XXX = ±.005          ANGLE = .42°</p>		<p>GD&amp;T TO ASME Y14.5M 1994</p>		<p>DRG. NO. 20414755D          SHEET 3 OF 5</p>		<p>DRG. NO. 20414755D          SHEET 3 OF 5</p>		<p>DRG. NO. 20414755D          SHEET 3 OF 5</p>	

REVISIONS			
NO.	DESCRIPTION	DATE	APPROVED
2	REVISION MADE PER EGR REV02797	2/1/02	7/6/02
4	REVISION MADE PER EGR REV03157	7/4/02	7/4/02
5	REVISION MADE PER EGR REV03526	4/17/06	4/17/06



NOTE:

WIRING BY CUSTOMER IN ACCORDANCE WITH LOCAL REGULATIONS.

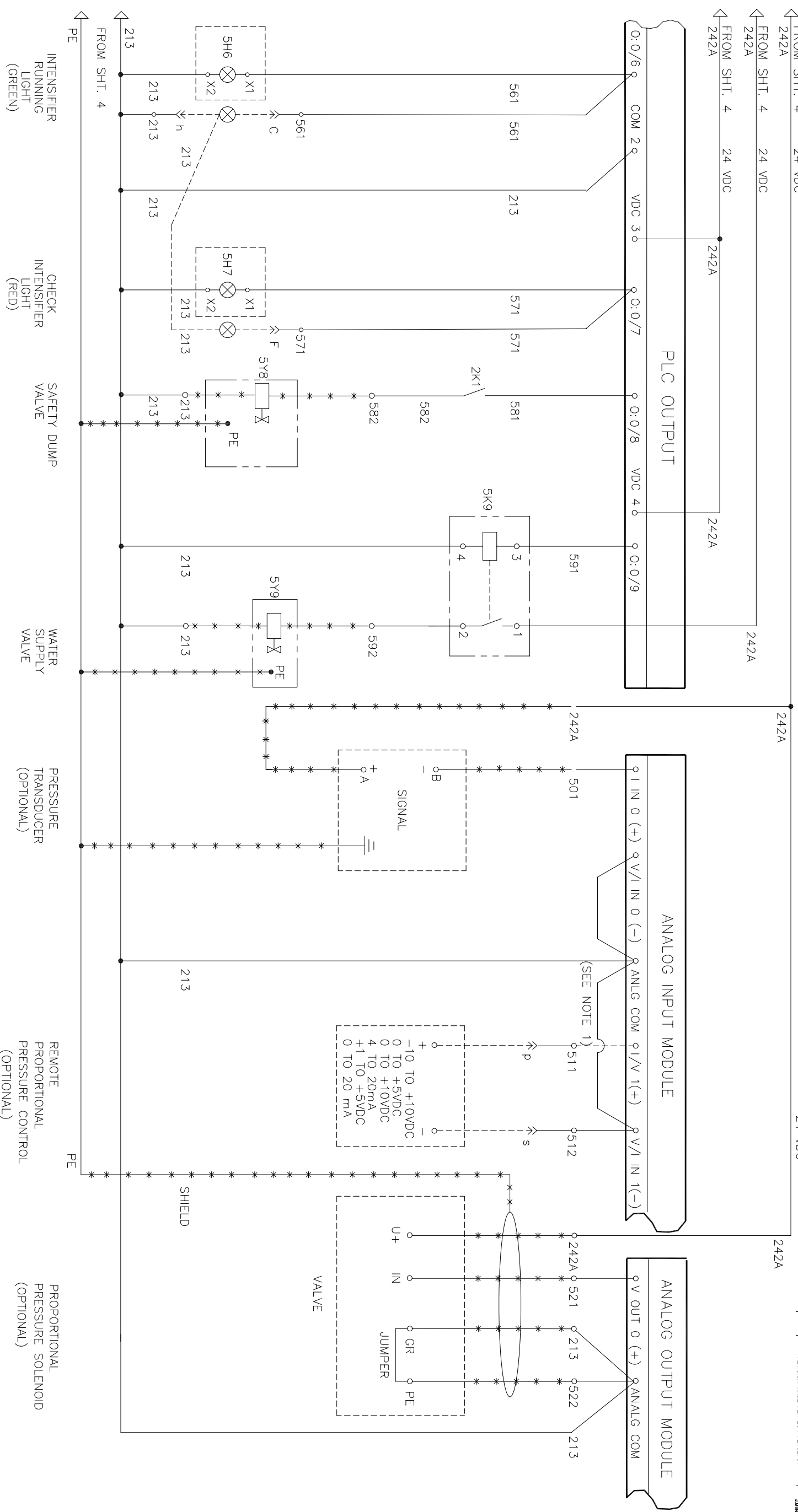
WIRING BY KMT EXTERNAL TO PANEL

ALL AC CONTROL VOLTAGE WIRES MUST BE RED IN COLOR

Copyright ©2003 KMT Waterjet Systems All Rights Reserved		PROPRIETARY NOTICE		STANDARD TOLERANCES UNLESS OTHERWISE NOTED: GD&T TO ASME Y14.5M 1994 REF. DWG. 49836604D		DRAWN BY & DATE B RUMBEL 7/7/02		TITLE SCHEM - ELEC SLV, Y - D, 24V 200 - 208, 100HP	
WARNING ! The export or reexport of this drawing is subject to U.S. Export Administration regulations and other applicable governmental restrictions or resipulations.		This document contains confidential and trade secret information, is the property of KMT Waterjet Systems, and is loaned and retention of the document occurs in confidence and agrees that, except as authorized in writing by KMT Waterjet Systems, it will not use the information contained herein for any other purpose. (1) not disclose to others either the document or the information contained herein; (2) not copy the document or other applicable governmental restrictions or resipulations.		GD&T TO ASME Y14.5M 1994 ALL DIMENSIONS IN INCHES [mm]		HEAT TREAT - HARDNESS -		CHECKED BY DATE 7/10/02	
Copyright ©2003 KMT Waterjet Systems All Rights Reserved		PROPRIETARY NOTICE		STANDARD TOLERANCES UNLESS OTHERWISE NOTED: GD&T TO ASME Y14.5M 1994 REF. DWG. 49836604D		DRAWN BY & DATE B RUMBEL 7/7/02		TITLE SCHEM - ELEC SLV, Y - D, 24V 200 - 208, 100HP	
WARNING ! The export or reexport of this drawing is subject to U.S. Export Administration regulations and other applicable governmental restrictions or resipulations.		This document contains confidential and trade secret information, is the property of KMT Waterjet Systems, and is loaned and retention of the document occurs in confidence and agrees that, except as authorized in writing by KMT Waterjet Systems, it will not use the information contained herein for any other purpose. (1) not disclose to others either the document or the information contained herein; (2) not copy the document or other applicable governmental restrictions or resipulations.		GD&T TO ASME Y14.5M 1994 ALL DIMENSIONS IN INCHES [mm]		HEAT TREAT - HARDNESS -		CHECKED BY DATE 7/10/02	
Copyright ©2003 KMT Waterjet Systems All Rights Reserved		PROPRIETARY NOTICE		STANDARD TOLERANCES UNLESS OTHERWISE NOTED: GD&T TO ASME Y14.5M 1994 REF. DWG. 49836604D		DRAWN BY & DATE B RUMBEL 7/7/02		TITLE SCHEM - ELEC SLV, Y - D, 24V 200 - 208, 100HP	
WARNING ! The export or reexport of this drawing is subject to U.S. Export Administration regulations and other applicable governmental restrictions or resipulations.		This document contains confidential and trade secret information, is the property of KMT Waterjet Systems, and is loaned and retention of the document occurs in confidence and agrees that, except as authorized in writing by KMT Waterjet Systems, it will not use the information contained herein for any other purpose. (1) not disclose to others either the document or the information contained herein; (2) not copy the document or other applicable governmental restrictions or resipulations.		GD&T TO ASME Y14.5M 1994 ALL DIMENSIONS IN INCHES [mm]		HEAT TREAT - HARDNESS -		CHECKED BY DATE 7/10/02	
Copyright ©2003 KMT Waterjet Systems All Rights Reserved		PROPRIETARY NOTICE		STANDARD TOLERANCES UNLESS OTHERWISE NOTED: GD&T TO ASME Y14.5M 1994 REF. DWG. 49836604D		DRAWN BY & DATE B RUMBEL 7/7/02		TITLE SCHEM - ELEC SLV, Y - D, 24V 200 - 208, 100HP	
WARNING ! The export or reexport of this drawing is subject to U.S. Export Administration regulations and other applicable governmental restrictions or resipulations.		This document contains confidential and trade secret information, is the property of KMT Waterjet Systems, and is loaned and retention of the document occurs in confidence and agrees that, except as authorized in writing by KMT Waterjet Systems, it will not use the information contained herein for any other purpose. (1) not disclose to others either the document or the information contained herein; (2) not copy the document or other applicable governmental restrictions or resipulations.		GD&T TO ASME Y14.5M 1994 ALL DIMENSIONS IN INCHES [mm]		HEAT TREAT - HARDNESS -		CHECKED BY DATE 7/10/02	
Copyright ©2003 KMT Waterjet Systems All Rights Reserved		PROPRIETARY NOTICE		STANDARD TOLERANCES UNLESS OTHERWISE NOTED: GD&T TO ASME Y14.5M 1994 REF. DWG. 49836604D		DRAWN BY & DATE B RUMBEL 7/7/02		TITLE SCHEM - ELEC SLV, Y - D, 24V 200 - 208, 100HP	
WARNING ! The export or reexport of this drawing is subject to U.S. Export Administration regulations and other applicable governmental restrictions or resipulations.		This document contains confidential and trade secret information, is the property of KMT Waterjet Systems, and is loaned and retention of the document occurs in confidence and agrees that, except as authorized in writing by KMT Waterjet Systems, it will not use the information contained herein for any other purpose. (1) not disclose to others either the document or the information contained herein; (2) not copy the document or other applicable governmental restrictions or resipulations.		GD&T TO ASME Y14.5M 1994 ALL DIMENSIONS IN INCHES [mm]		HEAT TREAT - HARDNESS -		CHECKED BY DATE 7/10/02	
Copyright ©2003 KMT Waterjet Systems All Rights Reserved		PROPRIETARY NOTICE		STANDARD TOLERANCES UNLESS OTHERWISE NOTED: GD&T TO ASME Y14.5M 1994 REF. DWG. 49836604D		DRAWN BY & DATE B RUMBEL 7/7/02		TITLE SCHEM - ELEC SLV, Y - D, 24V 200 - 208, 100HP	
WARNING ! The export or reexport of this drawing is subject to U.S. Export Administration regulations and other applicable governmental restrictions or resipulations.		This document contains confidential and trade secret information, is the property of KMT Waterjet Systems, and is loaned and retention of the document occurs in confidence and agrees that, except as authorized in writing by KMT Waterjet Systems, it will not use the information contained herein for any other purpose. (1) not disclose to others either the document or the information contained herein; (2) not copy the document or other applicable governmental restrictions or resipulations.		GD&T TO ASME Y14.5M 1994 ALL DIMENSIONS IN INCHES [mm]		HEAT TREAT - HARDNESS -		CHECKED BY DATE 7/10/02	







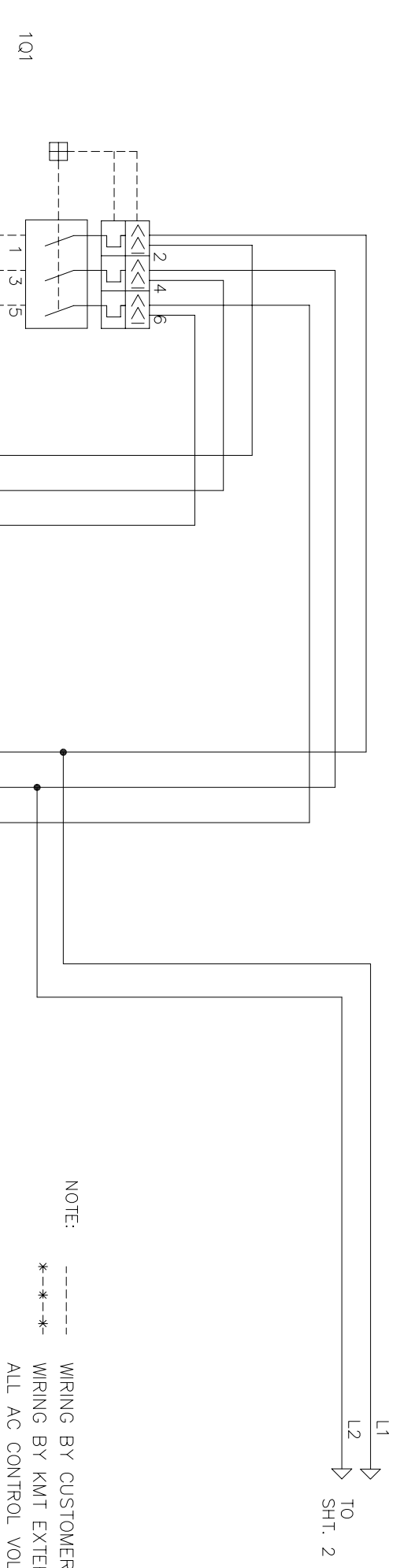
NOTE: VOLTAGE OR CURRENT CONTROL SPECIFIED BY CUSTOMER.  
 USE I IN 1(+) FOR CURRENT OR V IN 1(+) FOR  
 VOLTAGE CONTROL ON ANALOG MODULE.

----- WIRING BY CUSTOMER IN ACCORDANCE WITH LOCAL REGULATIONS  
 \*-\*-\* WIRING BY KMT EXTERNAL TO PANEL

ALL AC CONTROL VOLTAGE WIRES MUST BE RED IN COLOR

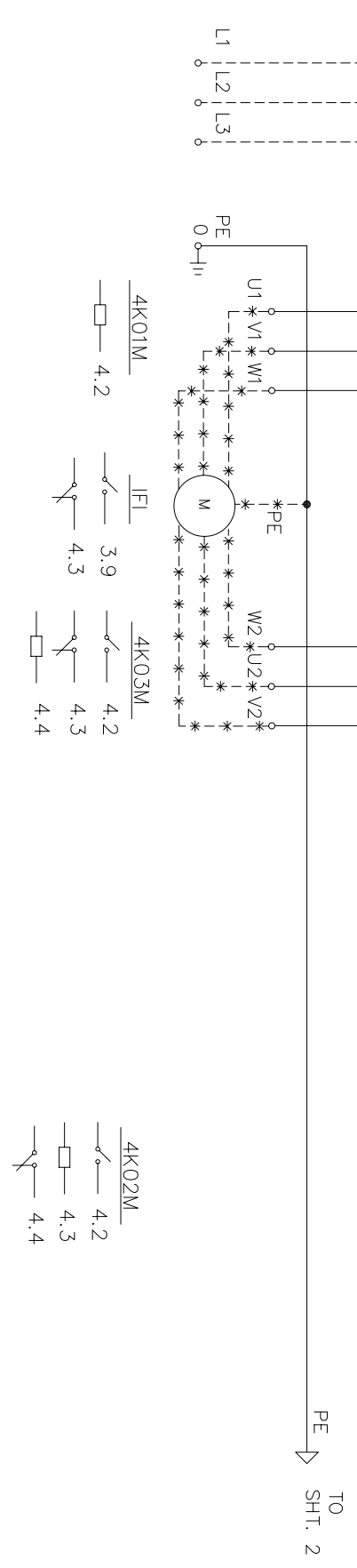
Copyright ©2003 KMT Waterjet Systems All Rights Reserved	PROPRIETARY NOTICE	STANDARD TOLERANCES UNLESS OTHERWISE NOTED: ALL DIMENSIONS IN INCHES [mm] BREAK SHARP EDGES AND CORNERS 015 SURFACE FINISH - HEAT TREAT X.XX = ±.003 X.XXX = ±.015 ANGLE = .42°	GD&T TO ASME Y14.5M 1994 REF. DWG 49836604D DRAWN BY & DATE B RUMBEL 7/7/02 CHECKED BY JDN 7/10/02 ENG. APPROVAL & DATE
WARNING ! The export or reexport of this drawing is prohibited by U.S. Export Administration regulations and other applicable governmental restrictions or regulations.	This document contains confidential and trade secret information, is the property of KMT Waterjet Systems, and is loaned and retention of the document accepts the document in confidence and agrees that, except as authorized in writing by KMT Waterjet Systems, it will not use the information contained herein for any other purpose. (1) not disclose to others either the document or the trade secret information therein; (2) not copy the document or other applicable governmental restrictions or regulations.	TITLE SCHEM - ELEC SLV, Y - D, 24V 200 - 208, 100HP	TITLE BLOCK REVISION: 1 SCALE: - SHEET 5 OF 5





MOTOR FLA

HP \ VOLTAGE	200	208	230	400	415	460
30	92	88	80	46	44	40
50	150	143	130	75	72	65
100	285	273	248	143	138	124

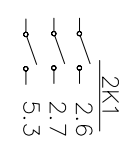
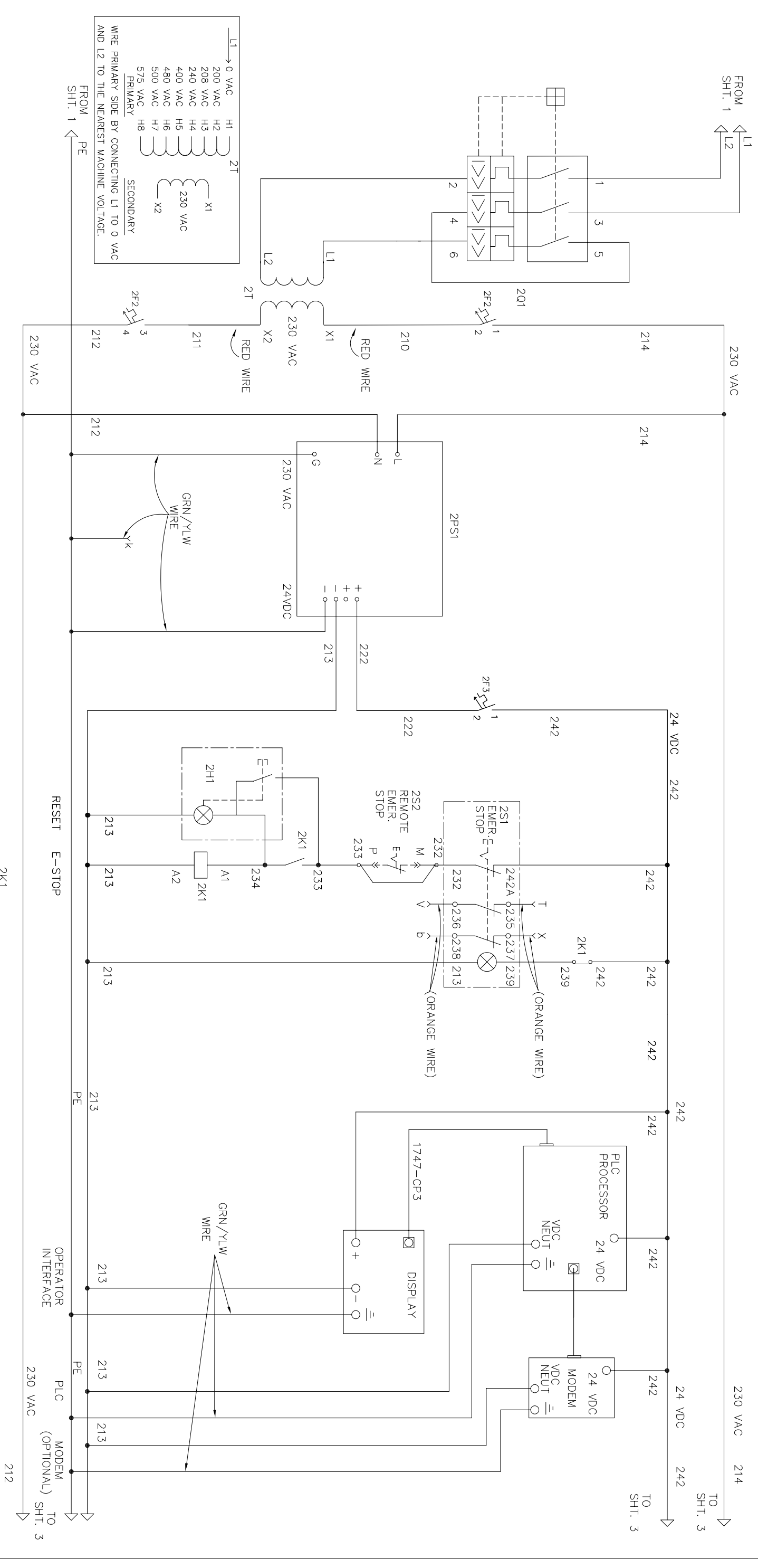


- NOTE:
- FOR UNITS WITH ELECTRONIC OVERLOAD SET CLASS 10 AND SET OVERLOAD TO 57% OF FLA

Copyright ©2003 KMT Waterjet Systems All Rights Reserved	PROPRIETARY NOTICE	STANDARD TOLERANCES UNLESS OTHERWISE NOTED: ALL DIMENSIONS IN INCHES [mm]	GD&T TO ASME Y14.5M 1994	REF. DWG 05148549D	DRAWN BY & DATE B RUMBEL 7/7/02	CHECKED BY DATE 7/1/02	ENG. APPROVAL & DATE	TITLE <b>KMT Waterjet Systems</b> ELEC SCHEM SLIV PLUS, Y-DELTA	DWG. NO. 49836604D	SCALE: -	THIRD ANGLE PROJECTION	REV. 10
WARNING ! The export or reexport of this drawing is prohibited without the prior written consent of KMT Waterjet Systems. This drawing is subject to U.S. Export Administration regulations and other applicable governmental restrictions or regulations.	This document contains confidential and trade secret information, is the property of KMT Waterjet Systems, and is loaned and retention of the document exceeds the document in confidence and agrees that, except as authorized in writing by KMT Waterjet Systems, it will not use the information contained herein for any other purpose. (1) not disclose to others either the document or the trade secret information therein; (2) not copy the document; (3) not disclose to others either the document or the trade secret information therein; (4) upon demand of KMT Waterjet Systems, return the document, all copies thereof, and all material copied therefrom.	HEAT TREAT - STANDARD TOLERANCES: XX = ±.063 XXX = ±.015 X.XXX = ±.005 ANGLE = .125	WATER - BREAK SHARP EDGES AND CORNERS .015	HARDNESS -	DATE APPROVAL & DATE	DATE	DATE	DATE	DATE	DATE	DATE	DATE

NEXT ASSEMBLY

REVISIONS			
NO	DESCRIPTION	DATE	APPROVED
7	ADDED 210 AND 214 NUMBERS	01/12/04	G.P.N.
8	CHANGED E-STOP PER FOR REV027/97.	10/12/04	G.P.N.



NOTE: ----- WIRING BY CUSTOMER IN ACCORDANCE WITH LOCAL REGULATIONS.  
 \*-\*-\*-\* WIRING BY KMT EXTERNAL TO PANEL

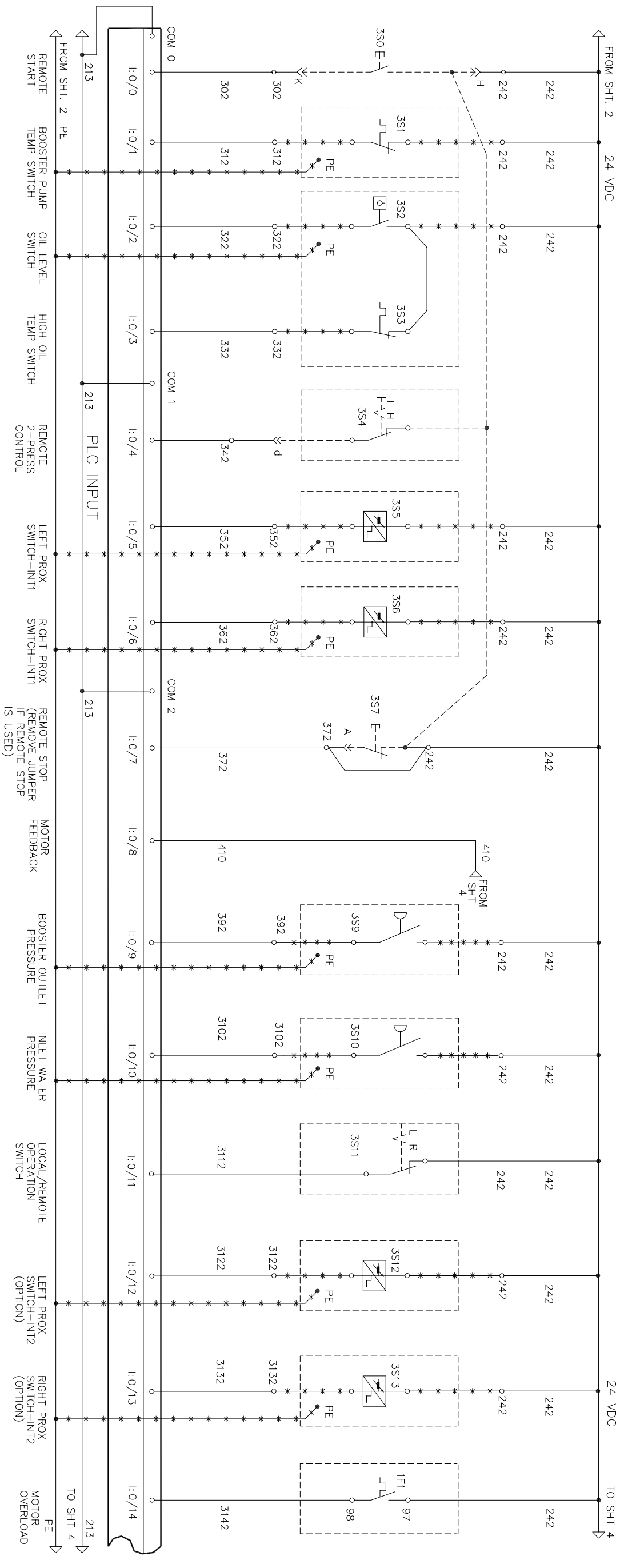
ALL AC CONTROL VOLTAGE WIRES MUST BE RED IN COLOR

Copyright ©2003 KMT Waterjet Systems All Rights Reserved		PROPRIETARY NOTICE		STANDARD TOLERANCES UNLESS OTHERWISE NOTED: ALL DIMENSIONS IN INCHES [mm]		GD&T TO ASME Y14.5M 1994		DATE: 01/12/04 DRAWN BY: B RUMBEL CHECKED BY: G.P.N. DATE: 10/12/04		TITLE: ELEC SCHEM SLIIV PLUS, Y-DELTA			
WARNING ! The export or reexport of this drawing is prohibited without the prior approval of KMT Waterjet Systems. Export Administration regulations and other applicable governmental restrictions or resipulations.		This document contains confidential and trade secret information, is the property of KMT Waterjet Systems, and is loaned and retention of the document occurs in confidence and agrees that, except as authorized in writing by KMT Waterjet Systems, it will not use the information contained herein for any other purpose. (3) not disclose to others either the document or the trade secret information therein; (2) not copy the document or the trade secret information therein; and (1) upon demand return the document, all copies thereof, and all material copied therefrom.		HEAT TREAT: - SURFACE FINISH: - CORNERS: 015		HARDNESS: -		ENG. APPROVAL & DATE: -		SCALE: -		REV: 10	
NEXT ASSEMBLY: -		DRAWING NO.: 49836604D		SHEET: 2		OF: 5		TITLE BLOCK REVISION: 1		KMT Waterjet Systems		ACAD	

NO	DESCRIPTION	DATE	APPROVED
1	REVISED PER REV01787	10/21/02	BR GHN

FROM SHT. 2 230 VAC 214

230 VAC TO SHT 4 214



TO SHT. 3 212

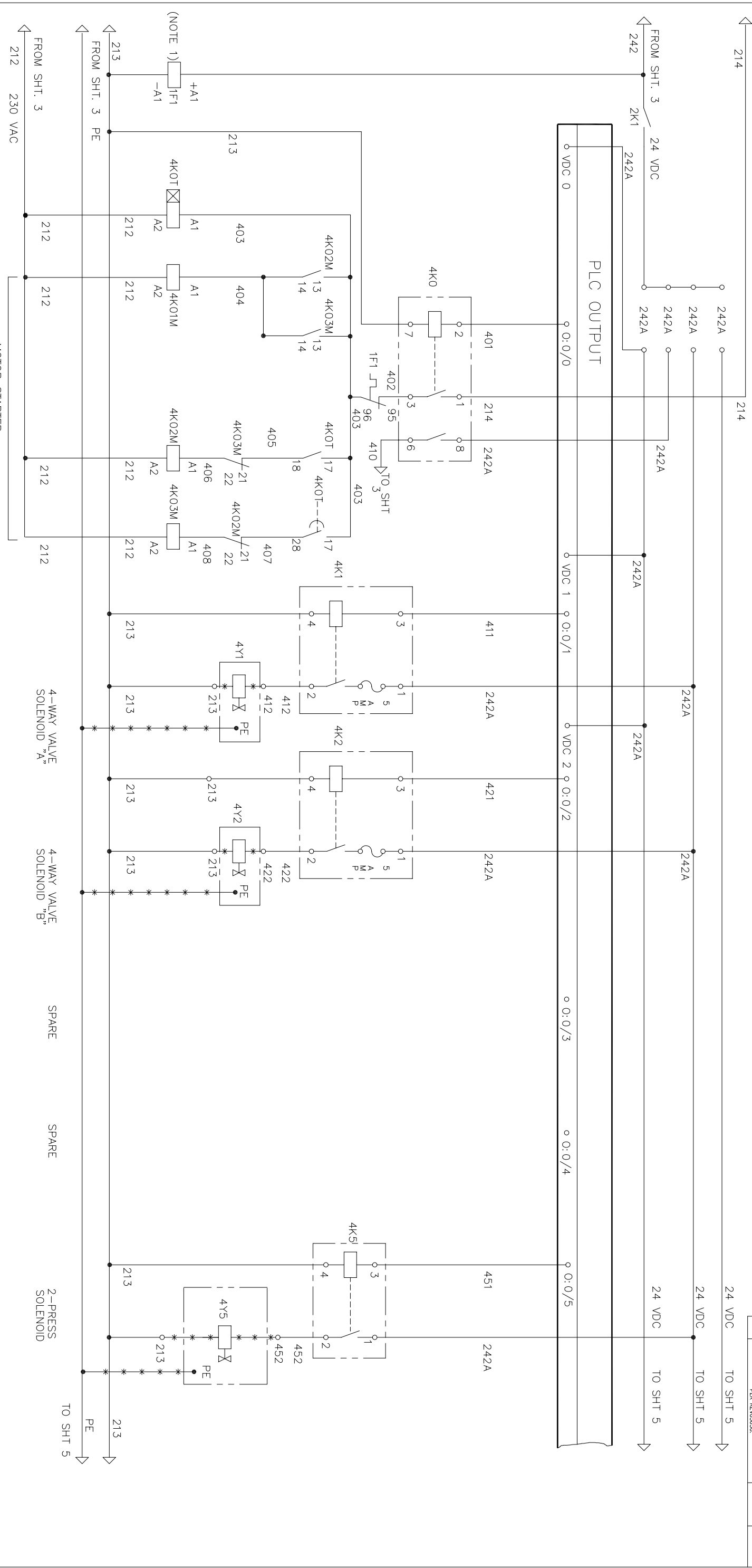
FROM SHT. 2 230 VAC 212

230 VAC TO SHT 4 212

-----  
 WIRING BY CUSTOMER IN ACCORDANCE WITH LOCAL REGULATIONS  
 \*\*\*\*\*  
 WIRING BY KMT EXTERNAL TO PANEL  
 ALL AC CONTROL VOLTAGE WIRES MUST BE RED IN COLOR

Copyright ©2003 KMT Waterjet Systems All Rights Reserved		PROPRIETARY NOTICE		STANDARD TOLERANCES UNLESS OTHERWISE NOTED: GD&T TO ASME Y14.5M 1994		DRAWN BY & DATE B RUMBEL 7/7/02		TITLE ELEC SCHEM SLIV PLUS, Y-DELTA	
WARNING ! The export or reexport of this drawing is subject to U.S. Export Administration regulations and other applicable governmental restrictions or regulations.		This document contains confidential and trade secret information, is the property of KMT Waterjet Systems, and is loaned and retention of the document accepts the document in confidence and agrees that, except as authorized in writing by KMT Waterjet Systems, it will not use the information contained herein for any other purpose. (1) not disclose to others either the document or the information contained herein; (2) not copy the document; (3) not disseminate the document, all copies thereof, and all material copied therefrom.		HEAT TREAT —		CHECKED BY DATE 7/02		DATE APPROVAL & DATE	
KMT Waterjet Systems		KMT Waterjet Systems		HEAT TREAT —		DATE APPROVAL & DATE		SCALE: —	
KMT Waterjet Systems		KMT Waterjet Systems		HEAT TREAT —		DATE APPROVAL & DATE		THIRD ANGLE PROJECTION	
KMT Waterjet Systems		KMT Waterjet Systems		HEAT TREAT —		DATE APPROVAL & DATE		TITLE BLOCK REVISION: 1	
KMT Waterjet Systems		KMT Waterjet Systems		HEAT TREAT —		DATE APPROVAL & DATE		SHEET 3 OF 5	

REVISIONS		
NO	DESCRIPTION	DATE
2	REVISED PER REV01825	11/27/02
6	ADDED 5 AMP FUSE TO SOLENOID. PER REV02308	12/01/03
9	REVISED PER REV02963	2/3/05
10	POWER FOR ELEC OVAL PER REV03650	7/14/06



NOTE:

- FOR USE ONLY WITH ELECTRONIC OVERLOADS THAT REQUIRE 24V POWER.

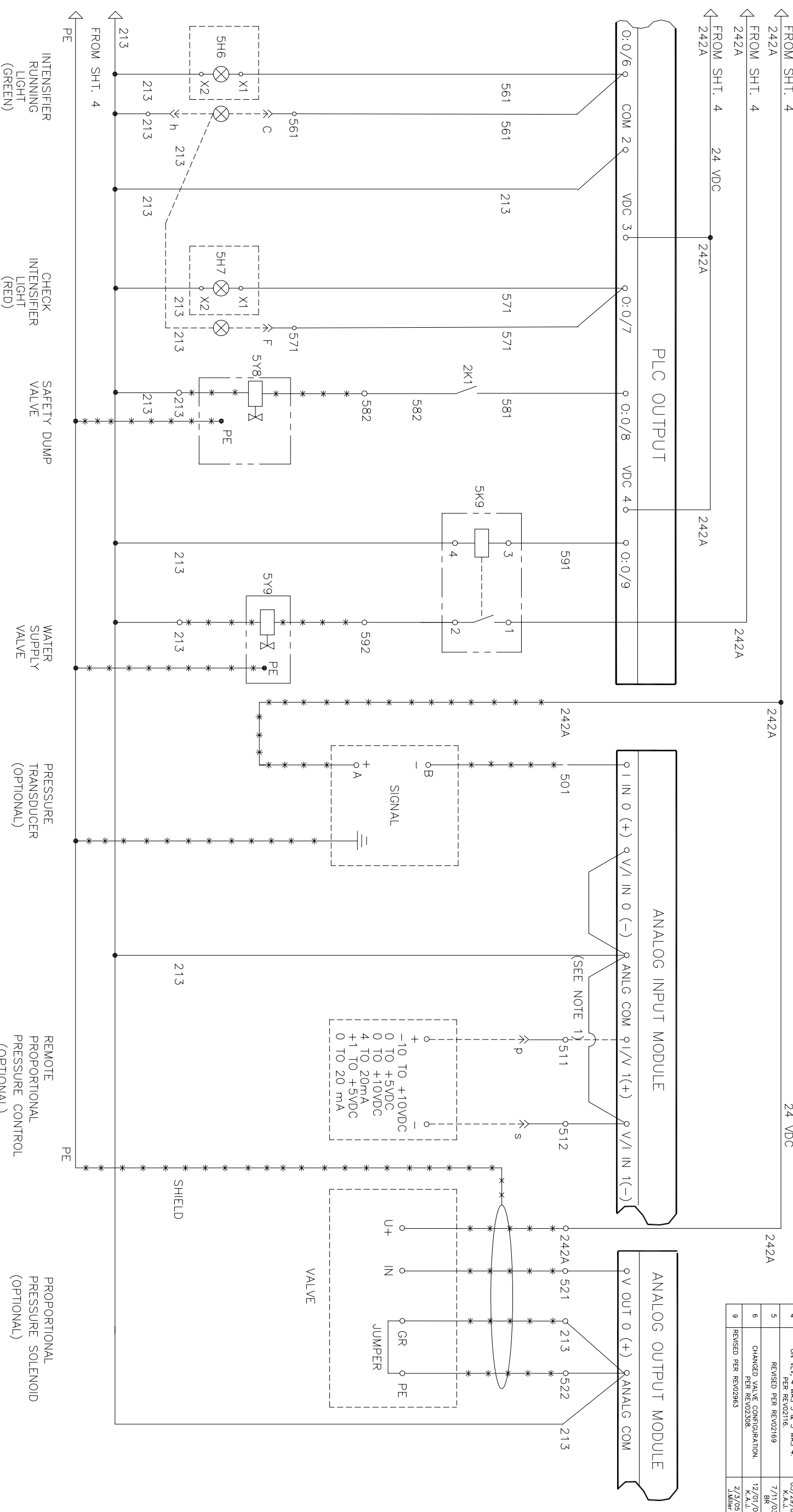
----- WIRING BY CUSTOMER IN ACCORDANCE WITH LOCAL REGULATIONS.

\*-\*-\* WIRING BY KMT EXTERNAL TO PANEL

ALL AC CONTROL VOLTAGE WIRES MUST BE RED IN COLOR

Copyright ©2003 KMT Waterjet Systems All Rights Reserved	PROPRIETARY NOTICE	STANDARD TOLERANCES UNLESS OTHERWISE NOTED: GD&T TO ASME Y14.5M 1994 REF. DIM. 05148549D	HEAT TREAT —	DRAMA BY & DATE B 7/7/02	SCALE: —
WARNING ! The export or reexport of this drawing is prohibited without the prior written approval of KMT Waterjet Systems. This drawing is subject to U.S. Export Administration regulations and other applicable governmental restrictions or resipulations.	This document contains confidential and trade secret information, is the property of KMT Waterjet Systems, and is loaned and retention of the document exceeds the document in confidence and agrees that, except as authorized in writing by KMT Waterjet Systems, it will not use the information contained herein for any other purpose. (1) not disclose to others either the document or the information contained herein; (2) not copy the document or the information contained herein; (3) not disseminate the information contained herein; (4) upon demand return the document, all copies thereof, and all material copied therefrom.	UNLESS OTHERWISE NOTED: COMMON CENTRILINE COAXIAL TO .005 BREAK SHARP EDGES AND CORNERS 015	WATERBARK —	CHECKED BY: RPN 7/1/02	DATE: 7/1/02
				TITLE: ELEC SCHEM SLIV PLUS, Y-DELTA DWG. NO.: 49836604D SCALE: — SHEET 4 OF 5	

REVISIONS		
NO	DESCRIPTION	DATE
2	REVISED PER REV01826	11/7/02
3	A & B WERE 1 & 2, REV01931.	1/21/03
4	ON VLV. 4 WAS 3 & 5 WAS 4. PER REV02116.	05/29/03
5	REVISED PER REV02169	7/11/03
6	CHANGED VALVE CONFIGURATION. PER REV02308.	12/01/03
9	REVISED PER REV02963	2/3/05



NOTE: VOLTAGE OR CURRENT CONTROL SPECIFIED BY CUSTOMER.  
 USE I IN 1(+) FOR CURRENT OR V IN 1(+) FOR  
 VOLTAGE CONTROL ON ANALOG MODULE.

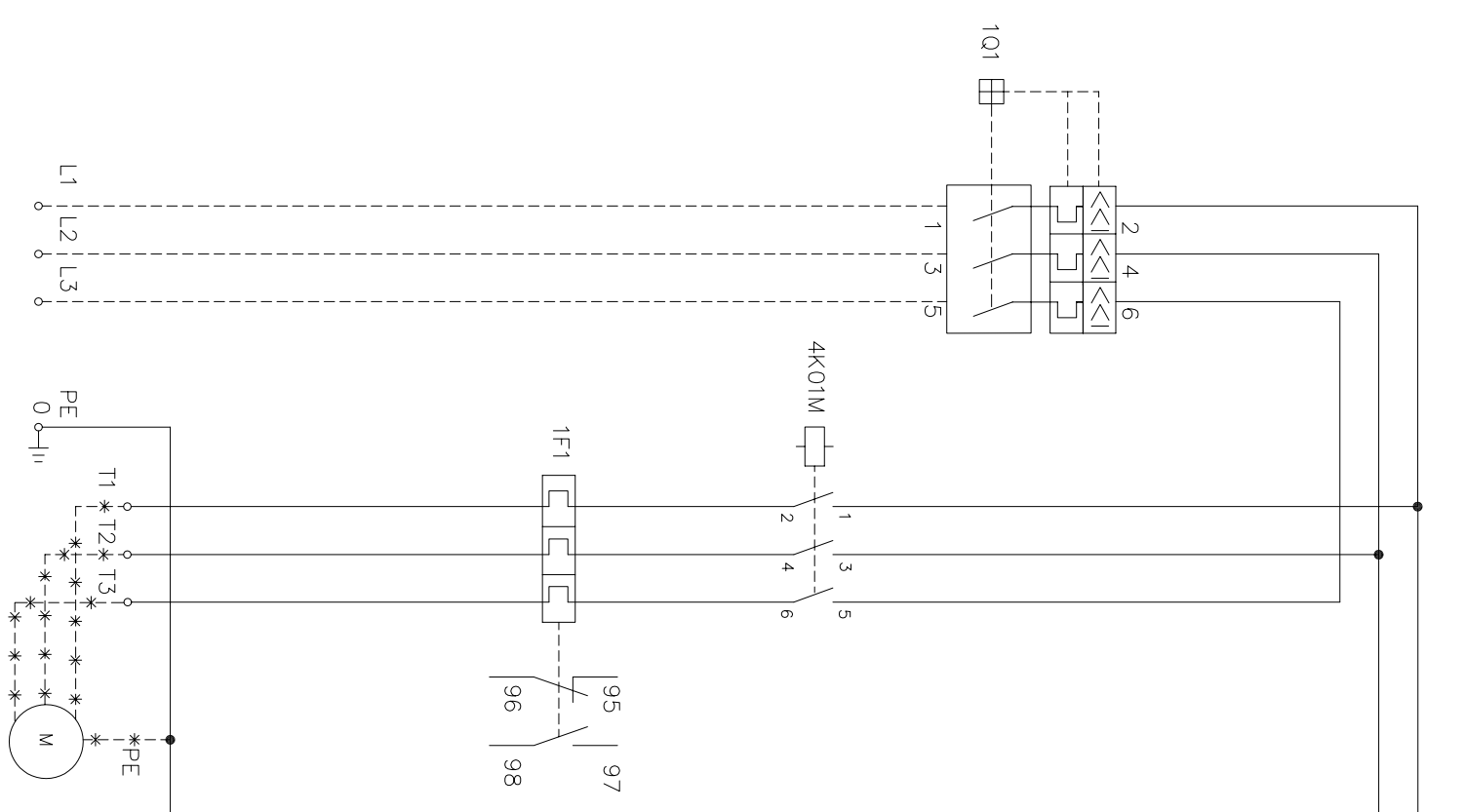
----- WIRING BY CUSTOMER IN ACCORDANCE WITH LOCAL REGULATIONS  
 \*-\*-\* WIRING BY KMT EXTERNAL TO PANEL  
 ALL AC CONTROL VOLTAGE WIRES MUST BE RED IN COLOR

Copyright ©2003 KMT Waterjet Systems All Rights Reserved	PROPRIETARY NOTICE	STANDARD TOLERANCES UNLESS OTHERWISE NOTED: ALL DIMENSIONS IN INCHES [mm] WATERJET BREAK SHARP EDGES AND CORNERS 015 HEAT TREAT STANDARD TOLERANCES: XX = ±.063 XXX = ±.015 ANGLE = .42°	GD&T TO ASME Y14.5M 1994 REF. DWG 05148549D B RUMBEL 7/7/02 CHECKED BY: JPN ENG. APPROVAL & DATE	TITLE <b>KMT Waterjet Systems</b> ELEC SCHEM SLIV PLUS, Y-DELTA DWG. NO. 49836604D SCALE: - THIRD ANGLE PROJECTION TITLE BLOCK REVISION: 1	REV. 10
----------------------------------------------------------------	--------------------	------------------------------------------------------------------------------------------------------------------------------------------------------------------------------------------------------------------------	-----------------------------------------------------------------------------------------------------------------	-----------------------------------------------------------------------------------------------------------------------------------------------------------------	---------

WARNING !  
 The export or reexport of this drawing is prohibited without the prior written approval of KMT Waterjet Systems. This drawing is subject to U.S. Export Administration regulations and other applicable governmental restrictions or regulations.

DRG. NO.	49836612D	SHT.	1	REV.	10
REVISIONS		DATE		APPROVED	
NO.		DESCRIPTION			

NOTE: -----  
 \*-\*-\*-\*  
 WIRING BY CUSTOMER IN ACCORDANCE WITH LOCAL REGULATIONS.  
 WIRING BY KMT EXTERNAL TO PANEL  
 ALL AC CONTROL VOLTAGE WIRES MUST BE RED IN COLOR



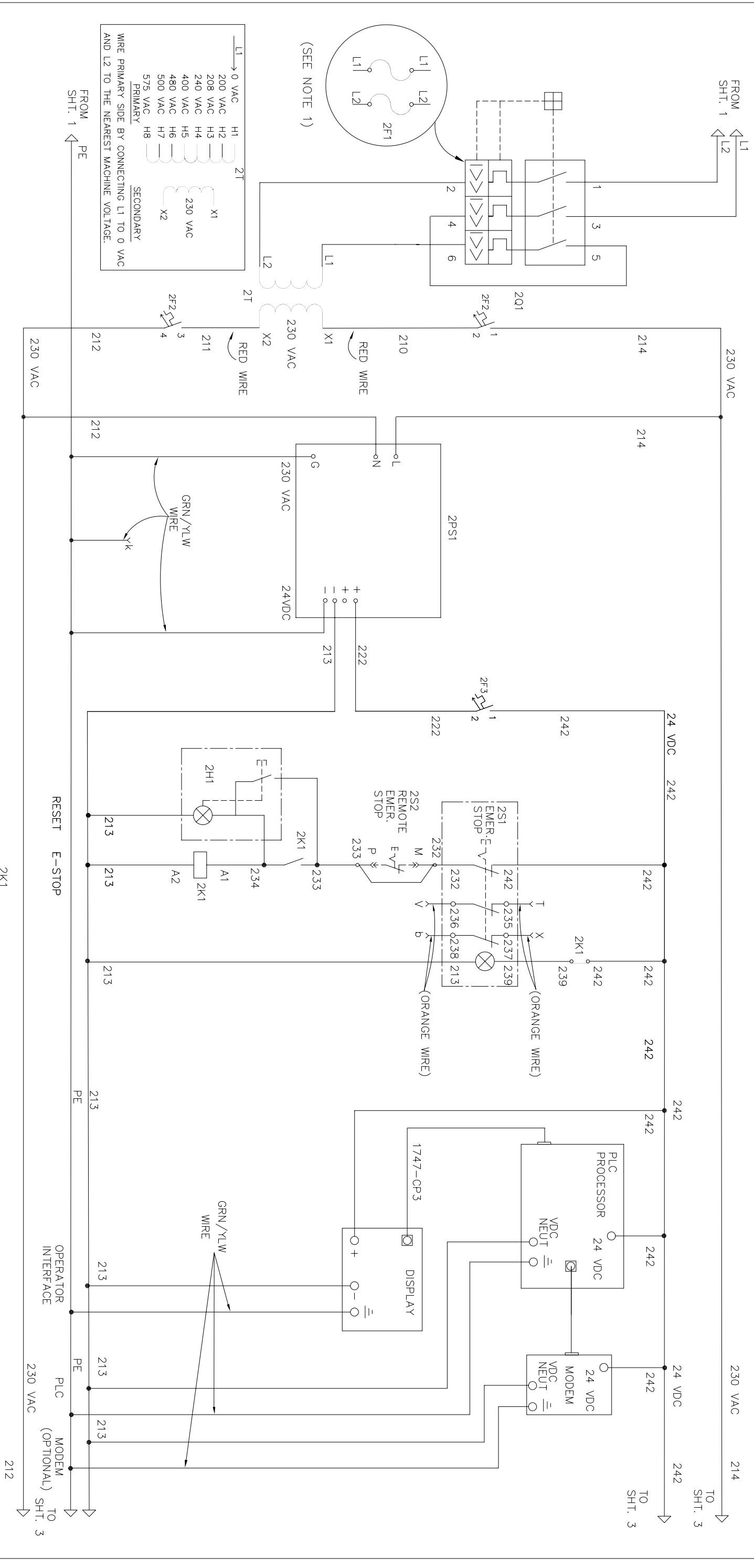
MOTOR FLA

HP \ VOLTAGE	200	208	230	400	415	460	575
30	92	88	80	46	44	40	32
50	150	143	130	75	72	65	52
100	285	273	248	143	138	124	99

TO  
 PE  
 SHT. 2

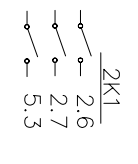
Copyright ©2003 KMT Waterjet Systems All Rights Reserved		PROPRIETARY NOTICE		STANDARD TOLERANCES UNLESS OTHERWISE NOTED: ALL DIMENSIONS IN INCHES [mm] COMMON CENTRAL LINE COAXIAL TO .005 BREAK SHARP EDGES AND CORNERS .015 HEAT TREAT SURFACE FINISH 6.3 STANDARD TOLERANCES: XX = ±.063 XXX = ±.015 ANGLE = .42°		GD&T TO ASME Y14.5M 1994 REF. DRG. 05148507D DRAWN BY & DATE B. RUMBEL 6/1/02 CHECKED BY DATE ENG. APPROVAL & DATE				TITLE SCHEM-ELECTRIC, SLV FULL VOLTAGE	
WARNING ! The export or reexport of this drawing is prohibited without the prior written consent of KMT Waterjet Systems. This drawing is subject to U.S. Export Administration regulations and other applicable governmental restrictions or regulations.		<p>(1) not disclose to others either the document or the information contained therein; (2) not copy the document or the information contained therein; (3) not use the information contained therein for any purpose other than that intended by KMT Waterjet Systems; (4) not use the information contained therein for any purpose other than that intended by KMT Waterjet Systems; (5) not disseminate the information contained therein to any other person without the prior written consent of KMT Waterjet Systems.</p>		<p>(1) not disclose to others either the document or the information contained therein; (2) not copy the document or the information contained therein; (3) not use the information contained therein for any purpose other than that intended by KMT Waterjet Systems; (4) not use the information contained therein for any purpose other than that intended by KMT Waterjet Systems; (5) not disseminate the information contained therein to any other person without the prior written consent of KMT Waterjet Systems.</p>		<p>(1) not disclose to others either the document or the information contained therein; (2) not copy the document or the information contained therein; (3) not use the information contained therein for any purpose other than that intended by KMT Waterjet Systems; (4) not use the information contained therein for any purpose other than that intended by KMT Waterjet Systems; (5) not disseminate the information contained therein to any other person without the prior written consent of KMT Waterjet Systems.</p>					
NEXT ASSEMBLY		SCALE: -		TITLE BLOCK REVISION: 2		SHEET 1		OF 5		REV. 10	

NO.	DESCRIPTION	DATE	APPROVED
7	ADDED 210 AND 211 NUMBERS	01/12/04	01/12/04
8	WAS 525 VOLT PER REL02504	3/19/04	3/19/04
9	CHANGED E-STOP PER ECR REV02797	10/12/04	10/12/04



NOTE: 1. REPLACE BREAKER WITH FUSES ON CSA PANELS ONLY.

----- WIRING BY CUSTOMER IN ACCORDANCE WITH LOCAL REGULATIONS.  
 \*-\*-\* WIRING BY KMT EXTERNAL TO PANEL  
 ALL AC CONTROL VOLTAGE WIRES MUST BE RED IN COLOR



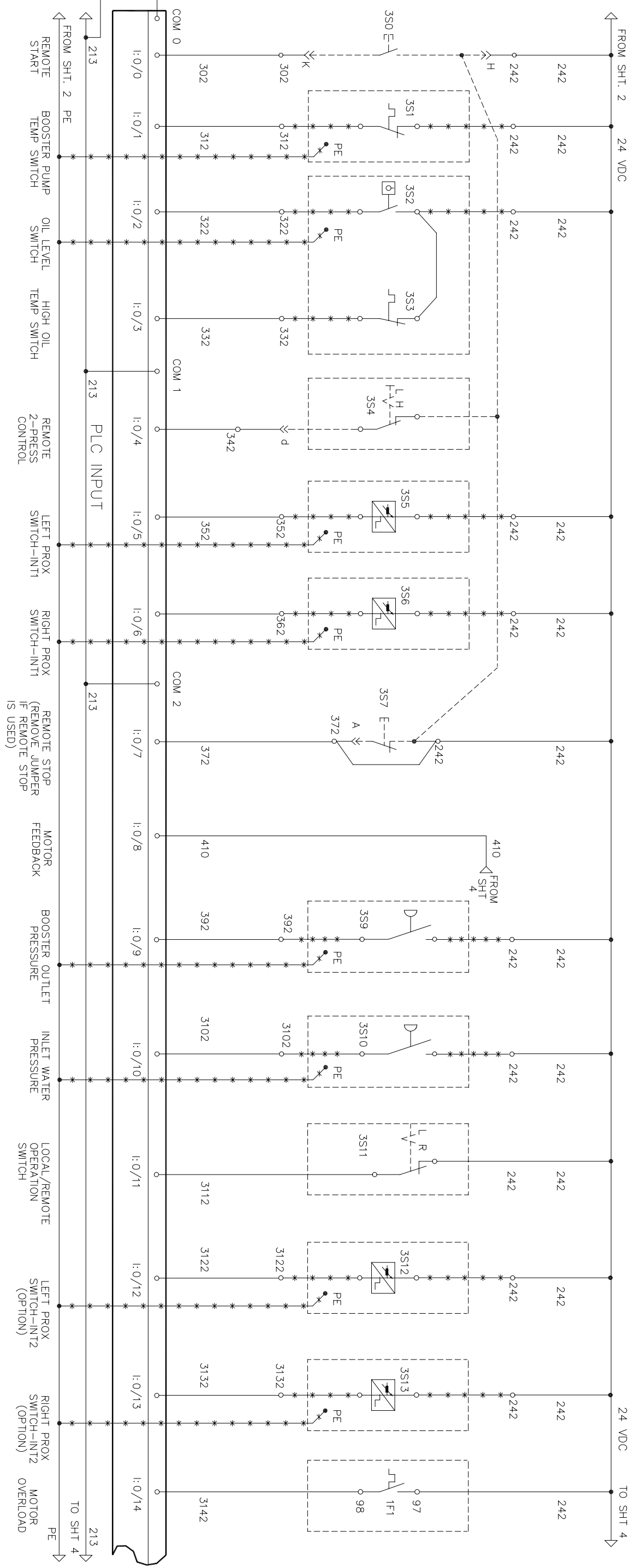
Copyright ©2003 KMT Waterjet Systems All Rights Reserved	PROPRIETARY NOTICE	STANDARD TOLERANCES UNLESS OTHERWISE NOTED: ALL DIMENSIONS IN INCHES [mm] WATERJET HEAT TREAT HARDNESS	GD&T TO ASME Y14.5M 1994 REF. DIM. 05148507D BPMW BR & DATE B. RUMBEL CHECKED BY CPJ 6/1/02 ENG. APPROVAL & DATE			<b>SCHEM-ELECTRIC, SLV FULL VOLTAGE</b> PKG. NO. 49836612D TITLE BLOCK REVISION 2	SHEET 2 OF 5 REV. 10
----------------------------------------------------------------	--------------------	--------------------------------------------------------------------------------------------------------------------	------------------------------------------------------------------------------------------------------------------------------------	--	--	-----------------------------------------------------------------------------------------	-------------------------

WARNING !  
 The export or reexport of this document, or the information contained herein, is prohibited by the Export Administration Regulations and other applicable governmental restrictions or requirements.



REV. NO.	DESCRIPTION	DATE	APPROVED
5			
10			

FROM SHT. 2 230 VAC 214 TO SHT 4 230 VAC 214

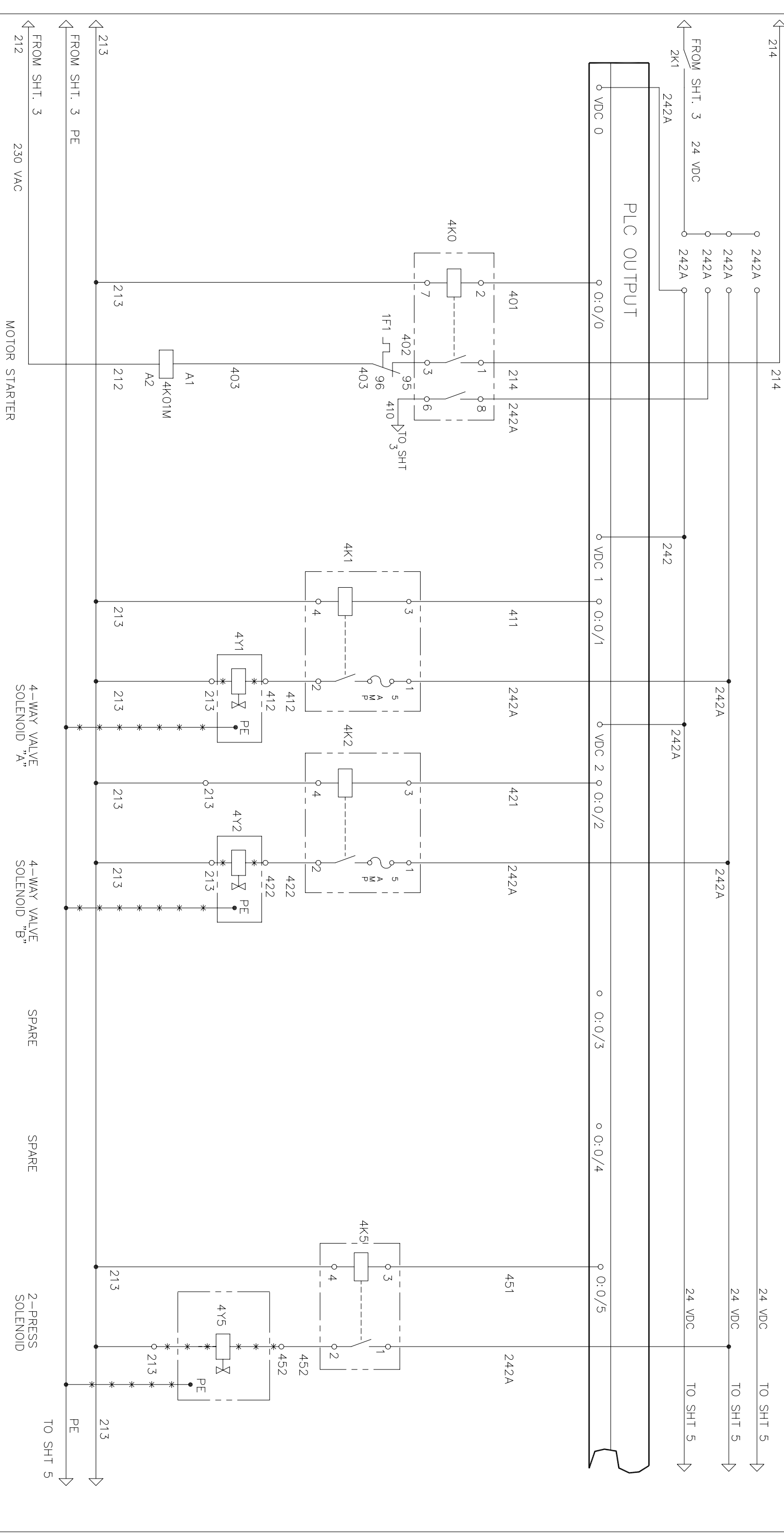


WIRING BY CUSTOMER IN ACCORDANCE WITH LOCAL REGULATIONS  
 WIRING BY KMT EXTERNAL TO PANEL

ALL AC CONTROL VOLTAGE WIRES MUST BE RED IN COLOR

Copyright ©2003 KMT Waterjet Systems All Rights Reserved	PROPRIETARY NOTICE	STANDARD TOLERANCES UNLESS OTHERWISE NOTED: COMMON CENTRAL LINE COAXIAL TO .005 BREAK SHARP EDGES AND CORNERS .015	GD&T TO ASME Y14.5M 1994	REF. DIM. 05148507D	<b>KMT</b> KMT Waterjet	TITLE SCHEM-ELECTRIC, SLV FULL VOLT
WARNING ! The export or reexport of this drawing is subject to U.S. Export Administration regulations and other applicable governmental restrictions or regulations.	(1) not disclose to others either the document or the information contained herein; (2) not copy the document or the information contained herein; (3) not use the information contained herein for any purpose other than that intended by KMT Waterjet Systems, Inc. (4) not use the information contained herein for any purpose other than that intended by KMT Waterjet Systems, Inc. upon demand return the document, all copies thereof, and all material copied therefrom.	HEAT TREAT —	HARDNESS —	ENG. APPROVAL & DATE —	SCALE: —	49836612D
						REV. 10

REVISIONS		DATE	APPROVED
3	REVISED PER REV01825	11/7/02	11/7/02
6	ADDED 5 AMP FUSE TO SOLENOID, REV02308	12/01/03	12/01/03
10	REVISIONS MADE PER ECR, REV02863	2/4/05	2/4/05



Copyright © 2003  
KMT Waterjet Systems  
All Rights Reserved

PROPRIETARY NOTICE

STANDARD TOLERANCES UNLESS OTHERWISE NOTED:  
GD&T TO ASME Y14.5M 1994

ALL DIMENSIONS IN INCHES [mm]

REF. DIM. 05148507D

DRAWN BY & DATE: B. RUMBEL 6/02

CHECKED BY DATE: 6/02

ENG. APPROVAL DATE: -

SCALE: -

TITLE BLOCK REVISION: 2

SHEET 4 OF 5

ACAD

TITLE: SCHEM-ELECTRIC, SLV FULL VOLT

49836612D

REV: 10

WARNING 1  
The export or reexport of this drawing, product, production drawing, or production drawing to any other country without the express written approval of KMT Waterjet Systems, Inc. is prohibited. Export Administration Regulations and other applicable governmental restrictions or regulations apply.

Copyright © 2003  
KMT Waterjet Systems  
All Rights Reserved

PROPRIETARY NOTICE

STANDARD TOLERANCES UNLESS OTHERWISE NOTED:  
GD&T TO ASME Y14.5M 1994

ALL DIMENSIONS IN INCHES [mm]

REF. DIM. 05148507D

DRAWN BY & DATE: B. RUMBEL 6/02

CHECKED BY DATE: 6/02

ENG. APPROVAL DATE: -

SCALE: -

TITLE BLOCK REVISION: 2

SHEET 4 OF 5

ACAD

TITLE: SCHEM-ELECTRIC, SLV FULL VOLT

49836612D

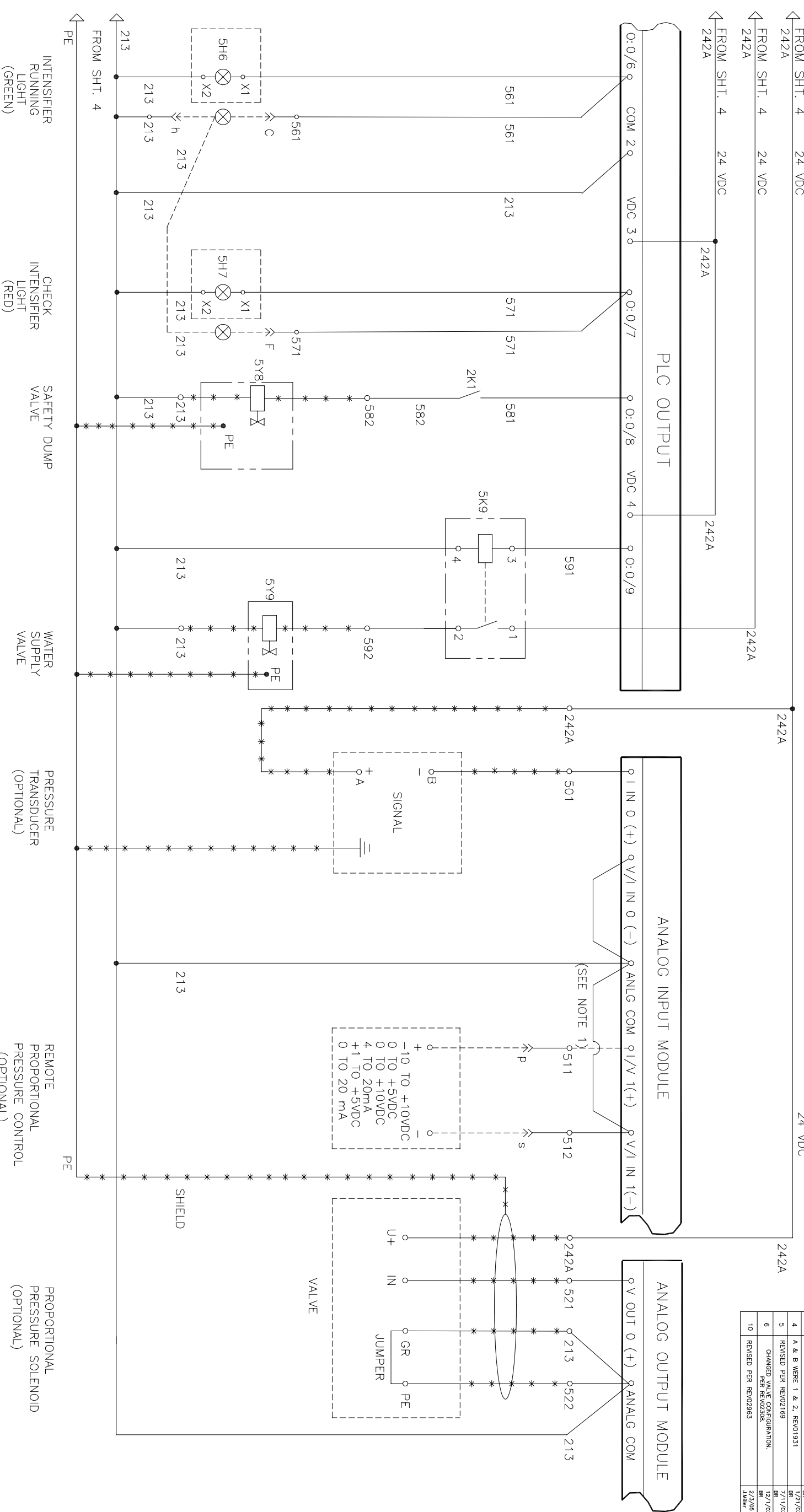
REV: 10

WIRING BY CUSTOMER IN ACCORDANCE WITH LOCAL REGULATIONS

WIRING BY KMT EXTERNAL TO PANEL

ALL AC CONTROL VOLTAGE WIRES MUST BE RED IN COLOR

REVISIONS			
NO	DESCRIPTION	DATE	APPROVED
1	REVISED PER REV01799	8/28/02	GMN
2	REVISED PER REV01811	11/01/02	GMN
3	REVISED PER REV01826	09/07/02	GMN
4	A & B WERE 1 & 2. REV01931	1/21/03	GMN
5	REVISED PER REV02169	7/11/03	GMN
6	CHANGED VALVE CONFIGURATION PER REV02208	12/1/03	GMN
10	REVISED PER REV02963	2/2/05	GMN



NOTE: VOLTAGE OR CURRENT CONTROL SPECIFIED BY CUSTOMER.  
 USE I IN 1(+) FOR CURRENT OR V IN 1(+) FOR  
 VOLTAGE CONTROL ON ANALOG MODULE.

----- WIRING BY CUSTOMER IN ACCORDANCE WITH LOCAL REGULATIONS  
 \*-\*-\*-\* WIRING BY KMT EXTERNAL TO PANEL  
 ALL AC CONTROL VOLTAGE WIRES MUST BE RED IN COLOR

Copyright © 2003 KMT Waterjet Systems All Rights Reserved	PROPRIETARY NOTICE	STANDARD TOLERANCES UNLESS OTHERWISE NOTED: ALL DIMENSIONS IN INCHES [mm]	HEAT TREAT —	DRG. APPROVAL & DATE —	SCALE: —
WARNING ! The export or reexport of this document is prohibited by the U.S. Export Administration regulations and other applicable governmental restrictions or regulations.	This document contains confidential and trade secret information, is the property of KMT Waterjet Systems, and its use, reproduction, distribution, or disclosure without the written consent of KMT Waterjet Systems is prohibited. Any unauthorized use, reproduction, distribution, or disclosure of this document is strictly prohibited. (1) not disclose to others either the document or the information contained therein; (2) not copy the document or the information contained therein; (3) not disclose the document or the information contained therein to others without the prior written consent of KMT Waterjet Systems.	BREAK SHARP EDGES AND CORNERS 015	DRG. NO. 05148507D	DATE 6/02	DRG. NO. 49836612D
KMT Waterjet		SCHEM-ELECTRIC, SLV FULL VOLT		SHEET 5 OF 5	



MATERIAL SAFETY DATA SHEET

HIGH PURITY GOOP™

November 2003

1. PRODUCT IDENTIFICATION

HIGH PURITY GOOP: Thread lubricant

Manufactured by:
Swagelok Company
29500 Solon Road
Solon, Ohio USA 44139
Tel: (440) 248-4600
Fax: (440) 349-5970

Emergency Contact:
Chemtrec (800) 424-9300

2. INGREDIENTS

Table with 4 columns: Ingredients, CAS #, WT%, PEL. Rows include Polychlorotrifluoroethylene, Polytetrafluoroethylene, and Amorphous Silica.

3. HEALTH HAZARD INFORMATION

- European Community Danger Group:..... None
Special Hazards for man or environment: ..... None
LD50/LC50 ..... Not Available

Routes of Entry

Table with 5 columns: Skin Contact, Skin Absorption, Eye Contact, Inhalation, Ingestion. Values: No, No, Yes, Yes, Yes.

4. FIRST AID MEASURES

- If inhaled (Overexposure): If person is affected by fumes, remove person to fresh air. Seek medical attention.
After contact with skin (Overexposure): Wash thoroughly with soap and water. If severe irritation develops, seek medical attention.
After contact with eyes: Rinse thoroughly with water for 15 minutes, seek medical attention. Do not rub eyes.
If swallowed: Seek medical attention.
Medical information: Unlikely to cause ill effects. Inhaling fumes of decomposition products can cause temporary influenza-like symptoms which are described as "polymer fume fever". Symptoms include fever, cough and malaise.

5. FIRE FIGHTING MEASURES



MATERIAL SAFETY DATA SHEET

**HIGH PURITY GOOP™**

November 2003

- Suitable extinguishing agents: Carbon dioxide, foam, agent suitable for environment.
- Not suitable for safety reasons: None known.
- Special dangers caused by substance preparation itself, by combustion products or gases formed: May decompose above 500°F/260°C to produce organo-chlorine compounds, organo-fluorine compounds, hydrogen fluoride, and chlorine gas.
- Additional information: None.

<b>Autoignition</b>	<b>UEL</b>	<b>LEL</b>	<b>Sensitivities</b>
Not Applicable	Not Available	Not Available	Not Available

**6. ACCIDENTAL RELEASE MEASURES**

- Measures for protection of people: Put on necessary protective equipment. Eye and hand protection as needed.
- Measures for protection of the environment: None required.
- Cleaning measures: Use absorbent material and suitable cleaner.
- Additional information: None.

**7. HANDLING AND STORAGE**

- Safety information: None.
- Information on protection from fire explosion: May decompose above 500°F/260°C to produce organo-chlorine or compounds, organo-fluorine compounds, hydrogen fluoride, and chlorine gas.
- Additional information: Store in a cool, dry place for optimal product performance.

**8. EXPOSURE CONTROLS AND PERSONAL PROTECTION**

- Precautionary measures to protect employees: None required.
- Respiratory protection: None required.
- Hand protection: Rubber gloves are recommended to minimize exposure.
- Eye protection: Safety glasses or goggles are recommended to minimize exposure.
- Skin protection: Wash hands after use.



MATERIAL SAFETY DATA SHEET

*HIGH PURITY GOOP™*

November 2003

**9. PHYSICAL AND CHEMICAL PROPERTIES**

<b>Appearance</b> Opaque-white	<b>Odor</b> Neutral	<b>pH</b> Not Applicable	<b>Density</b> 2.1 gm/cm <sup>3</sup>	<b>Vapor Pressure</b> <0.01mm Hg
<b>Boiling Point</b> Not Available	<b>Melting Point</b> Not Available	<b>Flash Point</b> Not Available	<b>Flammability</b> Not Available	<b>Explosive</b> Not Applicable

**10. STABILITY AND REACTIVITY**

- Conditions to avoid: May decompose above 500°F/260°C to produce organo-chlorine or compounds, organo-fluorine compounds, hydrogen fluoride, and chlorine gas.
- Materials to avoid: Sodium, potassium, barium, calcium, finely divided zinc, aluminum, magnesium, and beryllium. Avoid aluminum threaded connections where galling and seizure may initiate a reaction. Reacts with amines, liquid fluorine, and liquid chlorine trifluoride.
- Hazardous decomposition products: See Sections 4 and 5.

**11. TOXICOLOGICAL INFORMATION**

- Acute toxic properties: None known.
- Health effects: See Sections 4 and 5.
- Additional health effects: None known.

<b>Sensitization</b>	<b>Teratogenicity</b>	<b>Reproductive Toxicity</b>	<b>Mutagenicity</b>	<b>Synergistic Products</b>	<b>Carcinogenicity</b>
Not Available	Not Available	Not Available	Not Available	Not Available	Listed ingredients are not suspected carcinogens according to NTP, and IARC

**12. ECOLOGICAL INFORMATION**

- Mobility: Paste-like viscosity.
- Degradability: Not established.
- Accumulation: No known adverse bioaccumulation or biomagnification effects.
- Short / Long term effects on ecotoxicity: No known ecological effects.



MATERIAL SAFETY DATA SHEET

**HIGH PURITY GOOP™**

November 2003

---

**13. DISPOSAL CONSIDERATIONS**

---

- Appropriate methods of disposal: Unused product not considered a hazardous waste in the United States. Dispose of in a responsible manner.
- European Community(EC) considerations: Use appropriate waste codes based on ingredients.

---

**14. TRANSPORT INFORMATION**

---

- Transport precautions: Consult applicable regulations when transporting this product
- Additional information: None.

---

**15. REGULATORY INFORMATION**

---

- EC regulations: This product has been classified under CHIP-96 guidelines based on chemical content.
- US/Canadian regulation listings: SARA 313 - NO, TSCA - YES, Canada's Controlled Products - NO
- EC Relevant risk: None.
- EC Relevant safety: S: 37/39 - Wear suitable gloves and eye/face protection.  
S:20 - When using do not eat or drink.
- Additional information: Consult country codes for specific requirements.

---

**16. OTHER INFORMATION**

---

- Further information contact: Your Swagelok Distributor or the contacts listed in Section 1 of this sheet.
- Sources of information used to compile document: Properties of individual ingredients were used to compile this document. This Material Safety Data Sheet was designed to give the distributors and users of HIGH PURITY GOOP information to handle and use the product in a responsible manner.

<b>Preparation Data</b>		
Environmental and Safety Department	(440) 349-5955	November 2003

Revision Date: 12/10/2004

Issue date: 12/13/2004

**1. CHEMICAL PRODUCT AND COMPANY IDENTIFICATION**

**Product name:** Loctite(R) 222 Threadlocker Low Strength  
**Product Use:** Sealant  
**Company address:**  
Henkel Canada, Inc.  
2255 Meadowpine Boulevard  
Mississauga, Ontario L5N 7P2

**Item No. :** 21464  
**Region:** Canada  
**Contact Information:**  
Telephone: 905.814.6511  
Emergency telephone: 905.814.6511  
Internet: www.loctite.com

**2. COMPOSITION/INFORMATION ON INGREDIENTS**

<u>Hazardous components</u>	<u>%</u>	<u>ACGIH TLV</u>	<u>OSHA PEL</u>	<u>OTHER</u>
Polyglycol dimethacrylate 25852-47-5	30-60	None	None	None
Polyglycol oleate 9004-96-0	30-60	None	None	None
Silica, amorphous, treated 68909-20-6	5-10	10 mg/m <sup>3</sup> (Inhal)	20mppcf	6 mg/m <sup>3</sup>
Saccharin 81-07-2	1-5	None	None	None
Propylene glycol 57-55-6	1-5	None	None	None
Cumene hydroperoxide 80-15-9	1-5	None	None	1 ppm (6 mg/m <sup>3</sup> ) Skin (WEEL)

**3. HAZARDS IDENTIFICATION****EMERGENCY OVERVIEW**

**Physical state:** Liquid  
**Color:** Purple  
**Odor:** Mild

**WHMIS hazard class:** D.2.B

**WARNING:** CAUSES EYE IRRITATION.  
MAY CAUSE ALLERGIC SKIN REACTION.  
MAY CAUSE SKIN IRRITATION.  
MAY CAUSE RESPIRATORY TRACT IRRITATION.

**Relevant routes of exposure:** Skin, Inhalation, Eyes

**Potential Health Effects**

**Inhalation:** May cause respiratory tract irritation.  
**Skin contact:** May cause allergic skin reaction. May cause skin irritation.  
**Eye contact:** Contact with eyes will cause irritation.  
**Ingestion:** Not expected to be harmful by ingestion.

**Existing conditions aggravated by exposure:** Eye, skin, and respiratory disorders.

See Section 11 for additional toxicological information.

Item No. : 21464

Product name: Loctite(R) 222 Threadlocker Low Strength



## 4. FIRST AID MEASURES

<b>Inhalation:</b>	Remove to fresh air. If symptoms develop and persist, get medical attention.
<b>Skin contact:</b>	Wash with soap and water. Remove contaminated clothing and shoes. Wash clothing before reuse. Get medical attention if symptoms occur.
<b>Eye contact:</b>	Flush with copious amounts of water, preferably, lukewarm water for at least 15 minutes, holding eyelids open all the time. Get medical attention.
<b>Ingestion:</b>	Do not induce vomiting. Keep individual calm. Obtain medical attention.

## 5. FIRE-FIGHTING MEASURES

<b>Flash point:</b>	Greater than 93°C (200°F) Tagliabue closed cup
<b>Autoignition temperature:</b>	Not available
<b>Flammable/Explosive limits-lower %:</b>	Not available
<b>Flammable/Explosive limits-upper %:</b>	Not available
<b>Extinguishing media:</b>	Foam, dry chemical or carbon dioxide.
<b>Special fire fighting procedures:</b>	Wear self-contained breathing apparatus and full protective clothing, such as turn-out gear.
<b>Unusual fire or explosion hazards:</b>	None
<b>Hazardous combustion products:</b>	Oxides of carbon. Oxides of sulfur. Oxides of nitrogen. Irritating organic vapors.
<b>Sensitivity to mechanical impact:</b>	Not available.
<b>Sensitivity to static discharge:</b>	Not available.

## 6. ACCIDENTAL RELEASE MEASURES

<b>Environmental precautions:</b>	Prevent product from entering drains or open waters.
<b>Clean-up methods:</b>	Soak up with inert absorbent. Store in a partly filled, closed container until disposal.

## 7. HANDLING AND STORAGE

<b>Handling:</b>	Avoid contact with eyes, skin and clothing. Avoid breathing vapor and mist. Wash thoroughly after handling. Use only with adequate ventilation.
<b>Storage:</b>	For safe storage, store at or below 38°C (100°F). Keep in a cool, well ventilated area away from heat, sparks and open flame. Keep container tightly closed until ready for use.
<b>Incompatible products:</b>	Refer to Section 10.

For information on product shelf life contact Loctite Canada Customer Service at (905) 814-6511.

## 8. EXPOSURE CONTROLS / PERSONAL PROTECTION

<b>Engineering controls:</b>	No specific ventilation requirements noted, but forced ventilation may still be required if concentrations exceed occupational exposure limits.
<b>Respiratory protection:</b>	Use NIOSH approved respirator if there is potential to exceed exposure limit(s).

Item No. : 21464

Product name: Loctite(R) 222 Threadlocker Low Strength

**Skin protection:** Use impermeable gloves and protective clothing as necessary to prevent skin contact. Neoprene gloves. Butyl rubber gloves. Natural rubber gloves.

**Eye/face protection:** Safety goggles or safety glasses with side shields.

See Section 2 for exposure limits.

## 9. PHYSICAL AND CHEMICAL PROPERTIES

**Physical state:** Liquid  
**Color:** Purple  
**Odor:** Mild  
**Odor Threshold:** Not available  
**Vapor pressure:** Less than 5 mm Hg at 27°C (80°F)  
**pH:** Not applicable  
**Boiling point/range:** Greater than 149°C (300°F)  
**Melting point/range:** Not available  
**Specific gravity:** 1.08 at 20°C (68°F)  
**Vapor density:** Not available  
**Evaporation rate:** Not available  
**Solubility in water:** Slight  
**Partition coefficient (n-octanol/water):** Not available  
**VOC content:** 11.8%; 127 grams/liter (EPA Method 24)

## 10. STABILITY AND REACTIVITY

**Stability:** Stable.

**Hazardous polymerization:** Will not occur.

**Hazardous decomposition products:** Oxides of carbon. Oxides of sulfur. Oxides of nitrogen. Irritating organic vapors.

**Incompatibility:** Strong oxidizers.

**Conditions to avoid:** See "Handling and Storage" (Section 7) and "Incompatibility" (Section 10).

## 11. TOXICOLOGICAL INFORMATION

**Product toxicity data:** Acute oral LD50 greater than 10,000 mg/kg (rat). Acute dermal LD50 greater than 5000 mg/kg (rabbit).

**Toxicologically synergistic products:** Not available.

Refer to the following for Irritancy of Product, Sensitization to Product, Carcinogenicity, Reproductive Toxicity, Teratogenicity, and Mutagenicity.

### Ingredient Toxicity Data & Carcinogen Status

Hazardous components	LD50s & LC50s (NIOSH) :	Other LD50s and LC50s:	NTP Carcinogen	IARC Carcinogen	OSHA Carcinogen	ACGIH - Carcinogens
Polyglycol dimethacrylate 25852-47-5	None	None	No	No	No	No
Polyglycol oleate 9004-96-0	Oral LD50 (Mouse) > 25 g/kg	None	No	No	No	No
Silica, amorphous, treated 68909-20-6	None	None	No	No	No	No
Saccharin 81-07-2	Oral LD50 (Mouse) = 17 g/kg	None	No	No	No	No

Item No. : 21464

3 of 5

Product name: Loctite(R) 222 Threadlocker Low Strength

Propylene glycol 57-55-6	Oral LD50 (Rat) = 20 g/kg Dermal LD50 (Rabbit) = 20800 mg/kg Oral LD50 (Mouse) = 22 g/kg	None	No	No	No	No
Cumene hydroperoxide 80-15-9	Inhalation LC50 (Mouse) = 200 ppm Inhalation LC50 (Rat) = 220 ppm Oral LD50 (Rat) = 382 mg/kg	None	No	No	No	No

### Literature Referenced Target Organ & Other Health Effects

Hazardous components	Health Effects/Target Organs
Polyglycol dimethacrylate 25852-47-5	Allergen, Irritant
Polyglycol oleate 9004-96-0	Irritant
Silica, amorphous, treated 68909-20-6	No Target Organs
Saccharin 81-07-2	No Target Organs
Propylene glycol 57-55-6	Irritant
Cumene hydroperoxide 80-15-9	Allergen, Central nervous system, Corrosive, Irritant, Mutagen

## 12. ECOLOGICAL INFORMATION

**Ecological information:** Not available

## 13. DISPOSAL CONSIDERATIONS

Information provided is for unused product only.

**Recommended method of disposal:** Dispose of in accordance with federal and local regulations.

## 14. TRANSPORT INFORMATION

### Canada Transportation of Dangerous Goods - Ground:

**Proper shipping name:** Unrestricted  
**Hazard class or division:** None  
**Identification number:** None  
**Packing group:** None

### International Air Transportation (ICAO/IATA):

**Proper shipping name:** Unrestricted  
**Hazard class or division:** None  
**Identification number:** None  
**Packing group:** None

### WaterTransportation (IMO/IMDG):

**Proper shipping name:** Unrestricted  
**Hazard class or division:** None  
**Identification number:** None  
**Packing group:** None  
**Marine pollutant:** None

Item No. : 21464

Product name: Loctite(R) 222 Threadlocker Low Strength

## 15. REGULATORY INFORMATION

### Canada Regulatory Information

**CEPA DSL/NDSL Status:** All components are listed on or are exempt from listing on the Domestic Substances List.

### United States Regulatory Information

**TSCA 8 (b) Inventory Status:** All components are listed or are exempt from listing on the Toxic Substances Control Act Inventory.

## 16. OTHER INFORMATION

This material safety data sheet contains changes from the previous version in sections: New Material Safety Data Sheet format.

This product has been classified in accordance with the hazard criteria of the Controlled Products Regulations and the MSDS contains all the information required by the Controlled Product Regulations.

**Prepared by:** Kyra Kozak Woods, Health and Regulatory Affairs Specialist

**DISCLAIMER:** The data contained herein are furnished for information only and are believed to be reliable. However, Henkel Corporation does not assume responsibility for any results obtained by persons over whose methods Henkel Corporation has no control. It is the user's responsibility to determine the suitability of Henkel's products or any production methods mentioned herein for a particular purpose, and to adopt such precautions as may be advisable for the protection of property and persons against any hazards that may be involved in the handling and use of any of Henkel Corporation's products. In light of the foregoing, Henkel Corporation specifically disclaims all warranties, express or implied, including warranties of merchantability and fitness for a particular purpose, arising from sale or use of Henkel Corporation's products. Henkel Corporation further disclaims any liability for consequential or incidental damages of any kind, including lost profits.

# JL-M MATERIAL SAFETY DATA SHEET

SECTION 1 – PRODUCT IDENTIFICATION	
<b>Product Name:</b> JL-M Lubricant <b>Revised:</b> 03/07/03 <b>Supercedes:</b> 03/17/00 <b>Prepared by:</b> C. Semerod <b>Emergency Information:</b> (412) 279-1149	<b>Manufacturer's Name:</b> Superbolt, Inc. <b>Manufacturer's Address:</b> 1000 Gregg Street Carnegie, PA 15106 <b>Manufacturer's Phone #:</b> (412) 279-1149
SECTION 2 – HAZARDOUS INGREDIENTS	
<b>CHEMICAL NAME:</b>	<b>CAS NO.:</b>
Molybdenum Disulfide	1317-33-5
Silica, Fused	60676-86-0
Graphite	7782-42-5
Silica, Crystalline	14808-60-7
Lubricating Oils, Petroleum, Hydrotreated, Spent	64742-58-1
Residual Oils (Petroleum), Solvent Dewaxed	64742-62-7
Solvent-Refined Heavy Paraffinic Distillate (Petroleum)	64741-88-4
Solvent –Dewaxed Hydrotreated Heavy Paraffinic Distillate (Petroleum)	64742-65-0
Hydrotreated Heavy Paraffinic Distillate (Petroleum)	64742-54-7
Proprietary Additives Mixture (<1%)	
(*) Designates limits set by OSHA and the ACGIH for oil mist. This product is sold in a paste form so misting should not occur.	
SECTION 3 – PHYSICAL DATA	SECTION 4 – FIRE AND EXPLOSION DATA
<b>Appearance and Odor:</b> Dark Grey Paste, Mild Petroleum <b>Boiling Point:</b> > 500 degrees F <b>% Volatile:</b> 0% <b>Vapor Density:</b> > 1 (Air = 1) <b>Evaporation Rate:</b> < 1 (Ether = 1) <b>Specific Gravity:</b> 4.8 (Water = 1) <b>Vapor Pressure:</b> Essentially 0 (mm Hg) <b>Solubility in Water:</b> Insoluble <b>pH:</b> N/A	<b>Flash Point:</b> 338 degrees F <b>Lower Explosive Limit:</b> N/A <b>Upper Explosive Limit:</b> N/A <b>Extinguishing Media:</b> Carbon Dioxide, Regular Foam, Dry Chemical <b>Special Fire Fighting Procedures:</b> Fire may produce dense smoke, firefighters should wear self contained breathing apparatus. Use water to cool fire exposed containers. <b>Unusual Fire &amp; Explosion Hazards:</b> Decomposition and combustion by-products may be toxic. Heated containers may rupture or explode.
SECTION 5 – REACTIVITY DATA	SECTION 6 – STORAGE & HANDLING
<b>Stability:</b> Stable <b>Hazardous Polymerization:</b> Will not occur. <b>Incompatibility:</b> Avoid contact with oxidizing agents, heat, sparks or flame. <b>Hazardous Combustion By-Products:</b> Carbon Monoxide, Sulfur Dioxide, Aldehydes, and Nitrogen Oxides <b>Hazardous Decomposition:</b> Thermal decomposition may yield methacrylate monomers.	<b>Handling Precautions:</b> Use good personal hygiene practices. Clean contaminated clothing and protective equipment before reuse.  <b>Storage Precautions:</b> Store in a cool dry location. Keep container tightly closed when not in use and during transport. Keep away from open sparks or flames.
SECTION 7 – HEALTH HAZARDS	
<b>Effects of Overexposure:</b> <b>Skin:</b> May Cause Irritation <b>Eyes:</b> Eye Irritant. May cause redness and Blurred vision. <b>Ingestion:</b> Not Expected <b>Inhalation:</b> Not Expected (Chronic respiratory diseases may be aggravated by dust exposure.) <b>NFPA CODES:</b> Health: 1 Flammability: 1 Reactivity: 0 <b>Carcinogenicity:</b> Silica is a suspected carcinogen in a respirable form by the IARC and NTP however, not by the ACIGH or OSHA.	<b>First Aid Procedures:</b> <b>Skin:</b> Remove contaminated clothing from irritated area. Flush exposed area with mild soap and water. Seek medical attention if irritation persists. <b>Eyes:</b> Flush eyes with large quantities of water, holding eyelids open. Seek medical attention if irritation persists. <b>Ingestion:</b> Do not induce vomiting. If spontaneous vomiting occurs, keep head below hips to avoid aspiration into the lungs. Seek immediate medical attention. <b>Inhalation:</b> Remove to fresh air. Obtain medical attention if necessary.
SECTION 8 – SPECIAL PROTECTION	SECTION 9 – SPILL AND DISPOSAL PROCEDURES
<b>Eye Protection:</b> Safety Glasses or Face Shield <b>Protective Gloves:</b> Recommended <b>Respiratory Protection:</b> Avoid breathing dust, use an approved respirator if levels exceed OSHA limits. <b>Ventilation:</b> Local ventilation to maintain levels within OSHA limits.	<b>Spill Procedures:</b> Scrape or wipe up any spilled material. Wear proper protective equipment when cleaning up a spill. <b>Disposal Procedures:</b> Dispose of in accordance with any applicable federal, state, or local laws.

The information in this MSDS was obtained from sources which we believe are reliable. However, the information is provided without any representation or warranty, expressed or implied, regarding the accuracy or correctness. The conditions or methods of handling, storage, use and disposal of the product are beyond our control. For this and other reasons, we do not assume responsibility and expressly disclaim liability for loss, damage, or expense arising out of or in any way connected with the handling, storage, use or disposal of the product.



# LUBRIPLATE®

## MATERIAL SAFETY DATA SHEET

### Section 1

**PRODUCT NAME OR NUMBER:**

LUBRIPLATE Super FML-0, FML-1, FML-2

**FORMULA:**

Calcium Soap, USP Mineral Oil and Additives

**GENERIC/CHEMICAL NAME:**

Petroleum Lubricating Grease

**NSF Registration No's:**

125742, 125740, 125741

**Manufacturer's Name:**

Fiske Brothers Refining Co.

**Emergency Telephone Number:**

1-800-255-3924 - CHEM-TEL (24 hour)

**Address:**

1500 Oakdale Ave., Toledo, Ohio 43605 - 129 Lockwood St., Newark, NJ 07105

**Telephone Number for Information:**

419-691-2491 - Toledo Office

### Section 2 - Hazardous Ingredients/Identity Information

<u>Hazardous Components</u>	<u>OSHA PEL</u>	<u>ACGIH TLV</u>	<u>Other Limits Recommended</u>	<u>% (optional)</u>
-----------------------------	-----------------	------------------	---------------------------------	---------------------

Non-hazardous

**Hazardous Material Identification System (HMIS):** Health - 1, Flammability - 1, Reactivity - 0**Not a Controlled Product under (WHMIS) - Canada****Special Protection: See Section 9**

### Section 3 - Health Hazard Data

**Threshold Limit Value:** 5 mg/m<sup>3</sup> for oil mist in air. OSHA Regulation 29 CFR 1910.1000**Effects of Overexposure:** Prolonged or repeated skin contact may cause skin irritation. Product contacting the eyes may cause eye irritation. Human health risks vary from person to person. As a precaution, exposure to liquids, vapors, mists and fumes should be minimized. This product has a low order of acute oral toxicity, but minute amounts aspirated into the lungs during ingestion may cause mild to severe pulmonary injury.**Carcinogenicity:** NTP? No IARC Monographs? No OSHA Regulated? No

### Section 4 - Emergency and First Aid Procedures

**EYE CONTACT:** Flush with clear water for 15 minutes or until irritation subsides. If irritation persists, consult a physician.**SKIN CONTACT:** Remove any contaminated clothing and wash with soap and warm water. If injected by high pressure under skin, regardless of the appearance or its size, contact a physician IMMEDIATELY. Delay may cause loss of affected part of the body.**INHALATION:** Vapor pressure is very low and inhalation at room temperature is not a problem. If overcome by vapor from hot product, immediately remove from exposure and call a physician.**INGESTION:** If ingested, call a physician immediately. Do not induce vomiting.

### Section 5 - Fire and Explosion Hazard Data

**Flash Point (Method Used):** COC - 435°F **Flammable Limits:** LEL 0.9% UEL 7.0%**Extinguishing Media:** Foam, Dry Chemical, Carbon Dioxide or Water Spray (Fog)**Special Fire Fighting Procedures:** Cool exposed containers with water. Use air-supplied breathing equipment for enclosed or confined spaces.**Unusual Fire and Explosion Hazards:** Do not store or mix with strong oxidants. Empty containers retain residue. Do not cut, drill, grind, or weld, as they may explode.

**Section 6 - Physical/Chemical Characteristics**

<b>Boiling Point:</b>	>550°F	<b>Specific Gravity (H<sub>2</sub>O = 1):</b>	0.90 - 0.91
<b>Vapor Pressure (mm Hg.):</b>	<0.01	<b>Melting Point:</b>	Semi-solid
<b>Vapor Density (AIR = 1):</b>	>5	<b>Evaporation Rate: (Butyl Acetate = 1)</b>	<0.01
<b>Solubility in Water:</b>	Negligible		
<b>Appearance and Odor:</b>	Smooth, white grease with mineral oil odor.		

**Section 7 - Reactivity Data**

<b>Stability:</b>	Unstable Stable X	<b>Conditions to Avoid:</b>	N/A
<b>Incompatibility (Materials to Avoid):</b>	Avoid contact with strong oxidants like liquid chlorine, concentrated oxygen.		
<b>Hazardous Decomposition or Byproducts:</b>	May form SO <sub>2</sub> . If incomplete combustion, Carbon Monoxide.		
<b>Hazardous Polymerization:</b>	May Occur Will Not Occur X	<b>Conditions to Avoid:</b>	N/A

**Section 8 - Spill or Leak Procedures**

**Steps to be taken in case material is released or spilled:**

Scrape up grease, wash remainder with suitable petroleum solvent or add absorbent. Keep petroleum products out of sewers and watercourses. Advise authorities if product has entered or may enter sewers and watercourses.

**Waste disposal method:**

Assure conformity with applicable disposal regulations. Dispose of absorbed material at an approved waste disposal facility or site.

**SARA/TITLE III, Section 313 Status - Zinc Compounds - <6%**

**Section 9 - Special Protection Information**

<b>Respiratory Protection (Specify type):</b>	Normally not needed		
<b>Ventilation</b>	<b>Local Exhaust:</b>	Used to capture fumes and vapors	<b>Special:</b> N/A
	<b>Mechanical (General)</b>		<b>Other:</b> N/A
<b>Protective Gloves:</b>	Use oil-resistant gloves, if needed.	<b>Eye Protection:</b>	If chance of eye contact, wear goggles.
<b>Other Protective Equipment:</b>	Use oil-resistant apron, if needed.		

**Section 10 - Special Precautions**

**Precautions to be taken in handling and storing:**

Keep containers closed when not in use. Do not handle or store near heat, sparks, flame, or strong oxidants.

**Other Precautions:**

Remove oil-soaked clothing and laundry before reuse. Cleanse skin thoroughly after contact.

The above information is furnished without warranty, expressed or implied, except that it is accurate to the best knowledge of Fiske Brothers Refining Company. The data on these sheets relates only to the specific material designated herein. Fiske Brothers Refining Company assumes no legal responsibility for use or reliance upon this data.

600163-00 MOBIL DTE OIL HEAVY MEDIUM  
MATERIAL SAFETY DATA BULLETIN

---

---

## 1. PRODUCT AND COMPANY IDENTIFICATION

---

PRODUCT NAME: MOBIL DTE OIL HEAVY MEDIUM

SUPPLIER: EXXONMOBIL CORPORATION

3225 GALLOWS RD.

FAIRFAX, VA 22037

24 - Hour Health and Safety Emergency (call collect): 609-737-4411

24 - Hour Transportation Emergency (Primary) CHEMTREC: 800-424-9300  
(Secondary) 281-834-3296

Product and Technical Information:

Lubricants and Specialties: 800-662-4525 800-443-9966

Fuels Products: 800-947-9147

MSDS Fax on Demand: 613-228-1467

MSDS Internet Website: <http://emmsds.ihssolutions.com/>

---

## 2. COMPOSITION/INFORMATION ON INGREDIENTS

---

CHEMICAL NAMES AND SYNONYMS: PET. HYDROCARBONS AND ADDITIVES

GLOBALLY REPORTABLE MSDS INGREDIENTS:

None.

See Section 8 for exposure limits (if applicable).

---

## 3. HAZARDS IDENTIFICATION

---

Under normal conditions of use, this product is not considered hazardous according to regulatory guidelines (See section 15).

EMERGENCY OVERVIEW: Amber Liquid. DOT ERG No. : NA

POTENTIAL HEALTH EFFECTS: Under normal conditions of intended use, this product does not pose a risk to health. Excessive exposure may result in eye, skin or respiratory irritation.

For further health effects/toxicological data, see Section 11.

---

## 4. FIRST AID MEASURES

---

EYE CONTACT: Flush thoroughly with water. If irritation occurs, call a physician.

SKIN CONTACT: Wash contact areas with soap and water. Remove and clean oil soaked clothing daily and wash affected area. (See Section 16 - Injection Injury)

INHALATION: Not expected to be a problem. However, if respiratory irritation, dizziness, nausea, or unconsciousness occurs due to excessive vapor or mist exposure, seek immediate medical assistance. If breathing has stopped, assist ventilation with a mechanical device or mouth-to-mouth resuscitation.



INGESTION: Not expected to be a problem. Seek medical attention if discomfort occurs. Do not induce vomiting.

---

## 5. FIRE-FIGHTING MEASURES

---

EXTINGUISHING MEDIA: Carbon dioxide, foam, dry chemical and water fog.

SPECIAL FIRE FIGHTING PROCEDURES: Water or foam may cause frothing.

Use water to keep fire exposed containers cool. Water spray may be used to flush spills away from exposure. Prevent runoff from fire control or dilution from entering streams, sewers, or drinking water supply.

SPECIAL PROTECTIVE EQUIPMENT: For fires in enclosed areas, fire fighters must use self-contained breathing apparatus.

UNUSUAL FIRE AND EXPLOSION HAZARDS: None.

COMBUSTION PRODUCTS: Fumes, smoke, carbon monoxide, sulfur oxides, aldehydes and other decomposition products, in the case of incomplete combustion.

Flash Point C(F): > 204(400) (ASTM D-93).

Flammable Limits (approx.% vol.in air) - LEL: 0.9%, UEL: 7.0%

NFPA HAZARD ID: Health: 0, Flammability: 1, Reactivity: 0

---

## 6. ACCIDENTAL RELEASE MEASURES

---

NOTIFICATION PROCEDURES: Report spills/releases as required to appropriate authorities. U.S. Coast Guard and EPA regulations require immediate reporting of spills/releases that could reach any waterway including intermittent dry creeks. Report spill/release to Coast Guard National Response Center toll free number (800)424-8802. In case of accident or road spill notify CHEMTREC (800) 424-9300.

PROCEDURES IF MATERIAL IS RELEASED OR SPILLED:

LAND SPILL: Shut off source taking normal safety precautions. Take measures to minimize the effects on ground water. Recover by pumping or contain spilled material with sand or other suitable absorbent and remove mechanically into containers. If necessary, dispose of adsorbed residues as directed in Section 13.

WATER SPILL: Confine the spill immediately with booms. Warn other ships in the vicinity. Notify port and other relevant authorities. Remove from the surface by skimming or with suitable absorbents. If permitted by regulatory authorities the use of suitable dispersants should be considered where recommended in local oil spill procedures.

ENVIRONMENTAL PRECAUTIONS: Prevent material from entering sewers, water sources or low lying areas; advise the relevant authorities if it has, or if it contaminates soil/vegetation.

PERSONAL PRECAUTIONS: See Section 8

---

## 7. HANDLING AND STORAGE

---

HANDLING: No special precautions are necessary beyond normal good hygiene practices. See Section 8 for additional personal protection advice when handling this product.

STORAGE: Keep containers closed when not in use. Do not store in open or unlabelled containers. Store away from strong oxidizing

agents and combustible materials. Do not store near heat, sparks, flame or strong oxidants.

SPECIAL PRECAUTIONS: Prevent small spills and leakages to avoid slip hazard.

EMPTY CONTAINER WARNING: Empty containers retain residue (liquid and/or vapor) and can be dangerous. DO NOT PRESSURIZE, CUT, WELD, BRAZE, SOLDER, DRILL, GRIND OR EXPOSE SUCH CONTAINERS TO HEAT, FLAME, SPARKS, STATIC ELECTRICITY, OR OTHER SOURCES OF IGNITION; THEY MAY EXPLODE AND CAUSE INJURY OR DEATH. Do not attempt to refill or clean container since residue is difficult to remove. Empty drums should be completely drained, properly bunged and promptly returned to a drum reconditioner. All containers should be disposed of in an environmentally safe manner and in accordance with governmental regulations.

---

## 8. EXPOSURE CONTROLS/PERSONAL PROTECTION

---

### OCCUPATIONAL EXPOSURE LIMITS:

When mists/aerosols can occur, the following are recommended: 5 mg/m<sup>3</sup> (as oil mist)- ACGIH Threshold Limit Value (TLV), 10 mg/m<sup>3</sup> (as oil mist) - ACGIH Short Term Exposure Limit (STEL), 5 mg/m<sup>3</sup> (as oil mist) - OSHA Permissible Exposure Limit (PEL)

VENTILATION: If mists are generated, use adequate ventilation, local exhaust or enclosures to control below exposure limits.

RESPIRATORY PROTECTION: If mists are generated, and/or when ventilation is not adequate, wear approved respirator.

EYE PROTECTION: If eye contact is likely, safety glasses with side shields or chemical type goggles should be worn.

SKIN PROTECTION: Not normally required. When splashing or liquid contact can occur frequently, wear oil resistant gloves and/or other protective clothing. Good personal hygiene practices should always be followed.

---

## 9. PHYSICAL AND CHEMICAL PROPERTIES

---

Typical physical properties are given below. Consult Product Data Sheet for specific details.

APPEARANCE: Liquid

COLOR: Amber

ODOR: Mild

ODOR THRESHOLD-ppm: NE

pH: NA

BOILING POINT C(F): > 316(600)

MELTING POINT C(F): NA

FLASH POINT C(F): > 204(400) (ASTM D-93)

FLAMMABILITY (solids): NE

AUTO FLAMMABILITY C(F): NA

EXPLOSIVE PROPERTIES: NA

OXIDIZING PROPERTIES: NA

VAPOR PRESSURE-mmHg 20 C: < 0.1

VAPOR DENSITY: > 2.0

EVAPORATION RATE: NE

RELATIVE DENSITY, 15/4 C: 0.875

SOLUBILITY IN WATER: Negligible

PARTITION COEFFICIENT: > 3.5

VISCOSITY AT 40 C, cSt: 68.0

VISCOSITY AT 100 C, cSt: 8.7  
POUR POINT C(F): < -6(22)  
FREEZING POINT C(F): NE  
VOLATILE ORGANIC COMPOUND: NE  
DMSO EXTRACT, IP-346 (WT.%): <3, for mineral oil only  
NA=NOT APPLICABLE NE=NOT ESTABLISHED D=DECOMPOSES  
FOR FURTHER TECHNICAL INFORMATION, CONTACT YOUR MARKETING REPRESENTATIVE

---

## 10. STABILITY AND REACTIVITY

---

STABILITY (THERMAL, LIGHT, ETC.): Stable.  
CONDITIONS TO AVOID: Extreme heat and high energy sources of ignition.  
INCOMPATIBILITY (MATERIALS TO AVOID): Strong oxidizers.  
HAZARDOUS DECOMPOSITION PRODUCTS: Product does not decompose at ambient temperatures.  
HAZARDOUS POLYMERIZATION: Will not occur.

---

## 11. TOXICOLOGICAL DATA

---

### ---ACUTE TOXICOLOGY---

ORAL TOXICITY (RATS): Practically non-toxic (LD50: greater than 2000 mg/kg). ---Based on testing of similar products and/or the components.

DERMAL TOXICITY (RABBITS): Practically non-toxic (LD50: greater than 2000 mg/kg). ---Based on testing of similar products and/or the components.

INHALATION TOXICITY (RATS): Practically non-toxic (LC50: greater than 5 mg/l). ---Based on testing of similar products and/or the components.

EYE IRRITATION (RABBITS): Practically non-irritating. (Draize score: greater than 6 but 15 or less). ---Based on testing of similar products and/or the components.

SKIN IRRITATION (RABBITS): Practically non-irritating. (Primary Irritation Index: greater than 0.5 but less than 3). ---Based on testing of similar products and/or the components.

OTHER ACUTE TOXICITY DATA: Although an acute inhalation study was not performed with this product, a variety of mineral and synthetic oils, such as those in this product, have been tested. These samples had virtually no effect other than a nonspecific inflammatory response in the lung to the aerosolized mineral oil. The presence of additives in other tested formulations (in approximately the same amounts as in the present formulation) did not alter the observed effects.

### ---SUBCHRONIC TOXICOLOGY (SUMMARY)---

No significant adverse effects were found in studies using repeated dermal applications of similar formulations to the skin of laboratory animals for 13 weeks at doses significantly higher than those expected during normal industrial exposure. The animals were evaluated extensively for effects of exposure (hematology, serum chemistry, urinalysis, organ weights, microscopic examination of tissues etc.).

### ---REPRODUCTIVE TOXICOLOGY (SUMMARY)---

No teratogenic effects would be expected from dermal exposure, based on laboratory developmental toxicity studies of major components in this formulation and/or materials of similar composition.

### ---CHRONIC TOXICOLOGY (SUMMARY)---

Repeated and/or prolonged exposure may cause irritation to the skin, eyes or respiratory tract. Overexposure to oil mist may result in oil droplet deposition and/or granuloma formation. For mineral base oils: Base oils in this product are severely solvent refined and/or severely hydrotreated. Chronic mouse skin painting studies of severely treated oils showed no evidence of carcinogenic effects. These results are confirmed on a continuing basis using various screening methods such as Modified Ames Test, IP-346, and/or other analytical methods. For synthetic base oils: The base oils in this product have been tested in the Ames assay and other tests of mutagenicity with negative results. These base oils are not expected to be carcinogenic with chronic dermal exposures.

---SENSITIZATION (SUMMARY)---

Not expected to be sensitizing based on tests of this product, components, or similar products.

---

## 12. ECOLOGICAL INFORMATION

---

### ENVIRONMENTAL FATE AND EFFECTS:

In the absence of specific environmental data for this product, this assessment is based on information for representative products.

ECOTOXICITY: Available ecotoxicity data (LL50 >1000 mg/L) indicates that adverse effects to aquatic organisms are not expected from this product.

MOBILITY: When released into the environment, adsorption to sediment and soil will be the predominant behavior.

PERSISTENCE AND DEGRADABILITY: This product is expected to be inherently biodegradable.

BIOACCUMULATIVE POTENTIAL: Bioaccumulation is unlikely due to the very low water solubility of this product, therefore bioavailability to aquatic organisms is minimal.

---

## 13. DISPOSAL CONSIDERATIONS

---

WASTE DISPOSAL: Product is suitable for burning in an enclosed, controlled burner for fuel value. Such burning may be limited pursuant to the Resource Conservation and Recovery Act. In addition, the product is suitable for processing by an approved recycling facility or can be disposed of at an appropriate government waste disposal facility. Use of these methods is subject to user compliance with applicable laws and regulations and consideration of product characteristics at time of disposal.

RCRA INFORMATION: The unused product, in our opinion, is not specifically listed by the EPA as a hazardous waste (40 CFR, Part 261D), nor is it formulated to contain materials which are listed hazardous wastes. It does not exhibit the hazardous characteristics of ignitability, corrosivity, or reactivity. The unused product is not formulated with substances covered by the Toxicity Characteristic Leaching Procedure (TCLP). However, used product may be regulated.

---

## 14. TRANSPORT INFORMATION

---

USA DOT: NOT REGULATED BY USA DOT.  
RID/ADR: NOT REGULATED BY RID/ADR.  
IMO: NOT REGULATED BY IMO.  
IATA: NOT REGULATED BY IATA.  
STATIC ACCUMULATOR (50 picosiemens or less): YES

---

## 15. REGULATORY INFORMATION

---

US OSHA HAZARD COMMUNICATION STANDARD: When used for its intended purposes, this product is not classified as hazardous in accordance with OSHA 29 CFR 1910.1200.

EU Labeling: Product is not dangerous as defined by the European Union Dangerous Substances/Preparations Directives. EU labeling not required.

Governmental Inventory Status: All components comply with TSCA, EINECS/ELINCS, AICS, and DSL.

U.S. Superfund Amendments and Reauthorization Act (SARA) Title III: This product contains no "EXTREMELY HAZARDOUS SUBSTANCES". SARA (311/312) REPORTABLE HAZARD CATEGORIES: None. This product contains no chemicals subject to the supplier notification requirements of SARA (313) toxic release program.

THIS PRODUCT HAS BEEN AUTHORIZED BY USDA FOR USE UNDER THE FOLLOWING CATEGORY: This product is acceptable as a lubricant where there is no possibility of food contact (complies with earlier USDA guidelines for H-2 lubricant use).

The following product ingredients are cited on the lists below:

CHEMICAL NAME	CAS NUMBER	LIST CITATIONS
ZINC (ELEMENTAL ANALYSIS) (<0.01%)	7440-66-6	22
PHOSPHORODITHOIC ACID, O,O-DI	68649-42-3	22
C1-14-ALKYL ESTERS, ZINC SALTS (2:1) (ZDDP) (0.09%)		

--- REGULATORY LISTS SEARCHED ---

1=ACGIH ALL	6=IARC 1	11=TSCA 4	16=CA P65 CARC	21=LA RTK
2=ACGIH A1	7=IARC 2A	12=TSCA 5a2	17=CA P65 REPRO	22=MI 293
3=ACGIH A2	8=IARC 2B	13=TSCA 5e	18=CA RTK	23=MN RTK
4=NTP CARC	9=OSHA CARC	14=TSCA 6	19=FL RTK	24=NJ RTK
5=NTP SUS	10=OSHA Z	15=TSCA 12b	20=IL RTK	25=PA RTK
				26=RI RTK

Code key: CARC=Carcinogen; SUS=Suspected Carcinogen; REPRO=Reproductive

---

## 16. OTHER INFORMATION

---

USE: STEAM TURBINE OIL

NOTE: PRODUCTS OF EXXON MOBIL CORPORATION AND ITS AFFILIATED COMPANIES ARE NOT FORMULATED TO CONTAIN PCBS.

Health studies have shown that many hydrocarbons pose potential human health risks which may vary from person to person. Information provided on this MSDS reflects intended use. This product should not be used for other applications. In any case, the following advice should be considered:

INJECTION INJURY WARNING: If product is injected into or under the skin, or into any part of the body, regardless of the appearance of the wound or its size, the individual should be evaluated immediately by a physician as a surgical emergency. Even though initial symptoms from high pressure injection may be minimal or absent, early surgical

treatment within the first few hours may significantly reduce the ultimate extent of injury.

INDUSTRIAL LABEL

Under normal conditions of intended use, this product does not pose a risk to health. Excessive exposure may result in eye, skin or respiratory irritation. Always observe good hygiene measures. First Aid: Wash skin with soap and water. Flush eyes with water. If overcome by fumes or vapor, remove to fresh air. If ingested do not induce vomiting. If symptoms persist seek medical assistance. Read and understand the MSDS before using this product.

\*\*\*\*\*

For Internal Use Only: MHC: 1\* 1\* 1\* 1\* 1\*, MPPEC: A, TRN: 600163-00, ELIS: 400304, CMCS97: 970172, REQ: US - MARKETING, SAFE USE: L  
EHS Approval Date: 21AUG2001

\*\*\*\*\*

\*\*\*\*\*

Legally required information is given in accordance with applicable Information given herein is offered in good faith as accurate, but without guarantee. Conditions of use and suitability of the product for particular uses are beyond our control; all risks of use of the product are therefore assumed by the user and WE EXPRESSLY DISCLAIM ALL WARRANTIES OF EVERY KIND AND NATURE, INCLUDING WARRANTIES OF MERCHANTABILITY AND FITNESS FOR A PARTICULAR PURPOSE IN RESPECT TO THE USE OR SUITABILITY OF THE PRODUCT. Nothing is intended as a recommendation for uses which infringe valid patents or as extending any license under valid patents. Appropriate warnings and safe handling procedures should be provided to handlers and users. Use or re-transmission of the information contained herein in any other format than the format as presented is strictly prohibited. ExxonMobil neither represents nor warrants that the format, content or product formulas contained in this document comply with the laws of any other country except the United States of America.

\*\*\*\*\*

Copyright 2001 Exxon Mobil Corporation, All rights reserved



# Material Safety Data Sheet



## HYDROCLEAR MULTIPURPOSE R&O OIL 32, 46, 68, 100, 150, 220, 320, 460

### # 1. CHEMICAL PRODUCT/COMPANY IDENTIFICATION

HYDROCLEAR(R) MULTIPURPOSE R&O OIL

MSDS Code: HYDC0009 Revised: 29-July-2002

"HYDROCLEAR" is a registered trademark of Conoco.

ISO Grades: 32, 46, 68 100, 150, 220, 320, 460

Product Use: Industrial Oil

MANUFACTURER/DISTRIBUTOR

Conoco Inc.  
PO Box 2197  
Houston, TX 77252

PHONE NUMBERS

Product Information: 1-281-293-5550

Transport Emergency: CHEMTREC 1-800-424-9300 or  
1-703-527-3887 (call collect)

Medical Emergency: 1-800-342-5119 or 1-281-293-5119

WEB SITE: www.conoco.com

### # 2. COMPOSITION/INFORMATION ON INGREDIENTS

COMPONENTS	CAS NUMBER	%
Highly refined base oils	64742-54-7	0-99.5
Proprietary additives	64742-01-4	0-99.5
		<5

If oil mist is generated, exposure limits apply. See Section 8.

### # 3. HAZARDS IDENTIFICATION

#### --- EMERGENCY OVERVIEW ---

APPEARANCE / ODOR  
Clear and bright liquid / mild petroleum hydrocarbon odor.

OSHA REGULATORY STATUS  
This material is classified as non-hazardous under OSHA Regulations.

HMIS RATING Health: 1; Flammability: 1; Physical Hazard: 0.

NFPA RATING Health: 1; Flammability: 1; Instability: 0.

Potential Health Effects  
Primary Route of Entry: Skin

The product, as with many petroleum products, may cause minor skin,   
 eye, and lung irritation, but good hygienic practices can minimize   
 these effects.

Normal use of this product does not result in generation of an oil   
 mist. However if an oil mist is generated, overexposure can cause   
 minor and reversible irritation to the eyes, skin, and especially   
 the lungs. Proper personal protective equipment and sufficient   
 ventilation can provide adequate protection.

Carcinogenicity Information

None of the components present in this material at concentrations   
 equal to or greater than 0.1% are listed by IARC, NTP, OSHA or ACGIH   
 as a carcinogen.

-----  
4. FIRST AID MEASURES

Inhalation

If inhaled, remove to fresh air. If not breathing, give artificial   
 respiration. If breathing is difficult, give oxygen. Call a   
 physician.

Skin Contact

Wash skin thoroughly with soap and water. If irritation develops   
 and persists, consult a physician.

If injected under the skin, necrosis could occur. See physician.

Eye Contact

In case of contact, immediately flush eyes with plenty of water for   
 at least 15 minutes. Call a physician.

Ingestion

Material poses an aspiration hazard. If swallowed, do not induce   
 vomiting. Immediately give 2 glasses of water. Never give anything   
 by mouth to an unconscious person. Call a physician.

If vomiting occurs naturally, have victim lean forward to reduce the   
 risk of aspiration.

Notes to Physicians

Activated charcoal mixture may be administered. To prepare activated   
 charcoal mixture, suspend 50 grams activated charcoal in 400 mL water   
 and mix thoroughly. Administer 5 mL/kg, or 350 mL for an average   
 adult.

High velocity injection under the skin can cause a bloodless puncture   
 wound and result in necrosis. Immediate attention by a surgical   
 specialist is recommended.

-----  
5. FIRE FIGHTING MEASURES

Flammable Properties

Flash Point (minimum): 365 F (185 C) (Grade 32)   
 374 F (190 C) (Grade 46)   
 410 F (210 C) (Grade 68)   
 428 F (220 C) (Grade 100)   
 440 F (227 C) (Grade 150)



460 F (238 C) (Grade 220)   
 490 F (254 C) (Grade 320)   
 509 F (265 C) (Grade 460)   
  
 Flash Point (typical): 450 F (232 C) (Grade 32)   
 460 F (238 C) (Grade 46)   
 470 F (243 C) (Grade 68)   
 515 F (268 C) (Grade 100)   
 530 F (277 C) (Grade 150)   
 545 F (285 C) (Grade 220)   
 580 F (304 C) (Grade 320)   
 585 F (307 C) (Grade 460)   
  
 Method: COC   
 Autoignition: Not Available   
 Flammable limits in Air, % by Volume   
 LEL: Undetermined   
 UEL: Undetermined   
  
 Extinguishing Media   
 Water Spray, Foam, Dry Chemical, CO2.   
  
 Fire Fighting Instructions   
 Water or foam may cause frothing. Use water to keep fire-exposed   
 containers cool. Water may be used to flush spills away from   
 exposures.   
  
 Products of combustion may contain carbon monoxide, carbon dioxide,   
 and other toxic materials. Do not enter enclosed or confined space   
 without proper protective equipment including respiratory protection.   
-----  
6. ACCIDENTAL RELEASE MEASURES   
-----  
 Safeguards (Personnel)   
 NOTE: Review FIRE FIGHTING MEASURES and HANDLING (PERSONNEL) sections   
 before proceeding with clean-up. Use appropriate PERSONAL PROTECTIVE   
 EQUIPMENT during clean-up.   
  
 Remove source of heat, sparks, and flame.   
  
 Initial Containment   
 Dike spill. Prevent material from entering sewers, waterways, or   
 low areas.   
  
 Spill Clean Up   
 Recover free liquid for reuse or reclamation. Soak up with sawdust,   
 sand, oil dry or other absorbent material.   
-----  
7. HANDLING AND STORAGE   
-----  
 Handling (Personnel)   
 Avoid breathing vapors or mist. Avoid contact with eyes. Avoid   
 prolonged or repeated contact with skin. Wash thoroughly after   
 handling. Wash contaminated clothing prior to reuse.   
  
 Handling (Physical Aspects)   
 Close container after each use. Do not pressurize, cut, weld, braze,   
 solder, grind, or drill on or near full or empty container. Empty   
 container retains residue (liquid and/or vapor) and may explode in

heat of a fire.

Storage

Store in accordance with National Fire Protection Association

recommendations. Store in a cool, dry, well-ventilated place. Store

away from oxidizers, heat, sparks and flames.

-----

8. EXPOSURE CONTROLS/PERSONAL PROTECTION

-----

Engineering Controls

VENTILATION

Normal shop ventilation.

Personal Protective Equipment

RESPIRATORY PROTECTION

None normally required except in emergencies or when conditions

cause excessive airborne levels of mists or vapors. Select

appropriate NIOSH-approved respiratory protective equipment when

exposed to sprays or mists. Proper respirator selection should be

determined by adequately trained personnel and based on the

contaminant(s), the degree of potential exposure, and published

respirator protection factors.

PROTECTIVE GLOVES

Should be worn when the potential exists for prolonged or repeated

skin contact. NBR or neoprene recommended.

EYE PROTECTION

Safety glasses with side shields.

OTHER PROTECTIVE EQUIPMENT

Coveralls with long sleeves if splashing is probable.

Applicable Exposure Limits

If oil mist is generated, exposure limits apply.

PEL (OSHA): 5 mg/m3, 8 Hr. TWA

TLV (ACGIH): 5 mg/m3, 8 Hr. TWA, STEL 10 mg/m3

-----

# 9. PHYSICAL AND CHEMICAL PROPERTIES

-----

Physical Data

Appearance: Clear and bright

Odor: Mild petroleum hydrocarbon

Boiling Point: Not Available

Vapor Pressure: Nil

Vapor Density: >1 (Air=1.0)

% Volatiles: Nil

Evaporation Rate: Nil

Solubility in Water: Insoluble

Specific Gravity: 0.85-0.90 @ 60 F (16 C)

Pounds Per Gallon: 7.1-7.5 @ 60 F (16 C)

Viscosity (typical): cSt @ 40 C cSt @ 100 C

<input type="checkbox"/>	ISO 32	32.5	5.4	<input type="checkbox"/>
<input type="checkbox"/>	ISO 46	45	6.7	<input type="checkbox"/>
<input type="checkbox"/>	ISO 68	68.2	8.77	<input type="checkbox"/>
<input type="checkbox"/>	ISO 100	101.1	11.3	<input type="checkbox"/>
<input type="checkbox"/>	ISO 150	149	14.6	<input type="checkbox"/>

<input type="checkbox"/>	ISO 320	318	23.9	<input type="checkbox"/>
<input type="checkbox"/>	ISO 460	464	30.6	<input type="checkbox"/>
-----				
<input type="checkbox"/>	10. STABILITY AND REACTIVITY			<input type="checkbox"/>
-----				
<input type="checkbox"/>	Chemical Stability			<input type="checkbox"/>
<input type="checkbox"/>	Stable at normal temperatures and storage conditions.			<input type="checkbox"/>
<input type="checkbox"/>	Conditions to Avoid			<input type="checkbox"/>
<input type="checkbox"/>	Heat, sparks, and flames.			<input type="checkbox"/>
<input type="checkbox"/>	Incompatibility with Other Materials			<input type="checkbox"/>
<input type="checkbox"/>	Incompatible or can react with strong oxidizers.			<input type="checkbox"/>
<input type="checkbox"/>	Decomposition			<input type="checkbox"/>
<input type="checkbox"/>	Normal combustion forms carbon dioxide; incomplete combustion may produce carbon monoxide.			<input type="checkbox"/>
<input type="checkbox"/>	Polymerization			<input type="checkbox"/>
<input type="checkbox"/>	Polymerization will not occur.			<input type="checkbox"/>
-----				
<input type="checkbox"/>	11. TOXICOLOGICAL INFORMATION			<input type="checkbox"/>
-----				
<input type="checkbox"/>	Animal Data			<input type="checkbox"/>
<input type="checkbox"/>	Mouse skin painting studies have shown that highly refined petroleum lube base oils similar to ingredients in this product have not caused skin tumors. <input type="checkbox"/>			<input type="checkbox"/>
-----				
<input type="checkbox"/>	12. ECOLOGICAL INFORMATION			<input type="checkbox"/>
-----				
<input type="checkbox"/>	Ecotoxicological Information			<input type="checkbox"/>
<input type="checkbox"/>	No specific aquatic data available for this product.			<input type="checkbox"/>
-----				
<input type="checkbox"/>	13. DISPOSAL CONSIDERATIONS			<input type="checkbox"/>
-----				
<input type="checkbox"/>	Waste Disposal			<input type="checkbox"/>
<input type="checkbox"/>	Treatment, storage, transportation, and disposal must be in accordance with applicable Federal, State/Provincial, and Local regulations. Do not flush to surface water or sanitary sewer system. <input type="checkbox"/>			<input type="checkbox"/>
<input type="checkbox"/>	Container Disposal <input type="checkbox"/>			<input type="checkbox"/>
<input type="checkbox"/>	Empty drums should be completely drained, properly bunged, and promptly shipped to the supplier or a drum reconditioner. All other containers should be disposed of in an environmentally safe manner. <input type="checkbox"/>			<input type="checkbox"/>
-----				
<input type="checkbox"/>	14. TRANSPORTATION INFORMATION			<input type="checkbox"/>
-----				
<input type="checkbox"/>	Shipping Information			<input type="checkbox"/>
<input type="checkbox"/>	DOT:	Not regulated. <input type="checkbox"/>		<input type="checkbox"/>
<input type="checkbox"/>	IATA/IMDG:	Not restricted. <input type="checkbox"/>		<input type="checkbox"/>
<input type="checkbox"/>	Canada:	Not regulated. <input type="checkbox"/>		<input type="checkbox"/>
-----				
<input type="checkbox"/>	15. REGULATORY INFORMATION			<input type="checkbox"/>
-----				
<input type="checkbox"/>	U.S. Federal Regulations			<input type="checkbox"/>
<input type="checkbox"/>	OSHA HAZARD DETERMINATION <input type="checkbox"/>			<input type="checkbox"/>
<input type="checkbox"/>	This material is not known to be hazardous as defined by OSHA's Hazard Communication Standard, 29 CFR 1910.1200. <input type="checkbox"/>			<input type="checkbox"/>

CERCLA/SUPERFUND

Not applicable; this material is covered by the CERCLA petroleum

exclusion.

SARA, TITLE III, 302/304

Extremely Hazardous Substance: None

SARA, TITLE III, 311/312 HAZARD CLASSIFICATIONS

Acute: No

Chronic: No

Fire: No

Reactivity: No

Pressure: No

SARA, TITLE III, 313

Toxic Chemical: None

TSCA

Material and/or components are listed in the TSCA Inventory of

Chemical Substances (40 CFR 710).

RCRA

This material has been evaluated for RCRA characteristics and does

not meet hazardous waste criteria if discarded in its purchased

form. Because of product use, transformation, mixing, processing,

etc., which may render the resulting material hazardous, it is the

product user's responsibility to determine at the time of disposal

whether the material meets RCRA hazardous waste criteria.

CLEAN WATER ACT

The material contains the following ingredient(s) which is considered

hazardous if spilled into navigable waters and therefore reportable

to the National Response Center (1-800-424-8802).

Ingredient: Petroleum Hydrocarbons.

Reportable Quantity: Film or sheen upon or discoloration of

any water surface.

State Regulations (U.S.)

CALIFORNIA "PROP 65"

Ingredients subject to the Act: None.

PENNSYLVANIA WORKER & COMMUNITY RIGHT TO KNOW ACT

Ingredients subject to the Act: None.

Canadian Regulations

This is not a WHMIS Controlled Product.

-----

16. OTHER INFORMATION

-----

NOTE: This product or any other hydrocarbon-based lubricant should not be

used in non-diaphragm compressors that produce "breathing air"

unless the outlet is monitored continuously for carbon monoxide.

These lubricants can produce carbon monoxide when subjected to high

temperatures.

\_\_\_\_\_

The data in this Material Safety Data Sheet relates only to the

specific material designated herein and does not relate to use in

combination with any other material or in any process.

☐				☐
☐	Responsibility for MSDS:	DNA - SHE	☐	
☐	Address:	Conoco Inc.		☐
☐		PO Box 2197		☐
☐		Houston, TX 77252		☐
☐	Telephone:	1-281-293-5550		☐
☐	Web Site:	www.conoco.com☐		
☐			☐	
☐	# Indicates updated section.			☐
☐		End of MSDS		☐
☐☐				
☐☐				



Material Safety Data Sheet

Printed: 8/26/03

PQ AA 20

Product Identification and Use

MANUFACTURER'S NAME ANDEROL CANADA CORP.
700 THIRD LINE
OAKVILLE, ONTARIO L6J 5A3
EMERGENCY PHONE NUMBER (905) 827-9087 (ANDEROL)
(613) 996-6666 (CANUTEC)
SUPPLIER'S NAME SAME
PRODUCT IDENTIFIER PQ AA 20
PRODUCT CODE PQAA200011-1
PRODUCT USE FOOD GRADE LUBRICANT
WHMIS CLASSIFICATION NOT CONTROLLED
EXPOSURE LIMITS TLV: 5 MG/M3 (OIL)

HMIS RATING: 0 = NONE --> 4 = EXTREME
HEALTH 1 PROTECTION: G
FLAMMABILITY 1 SEE MSDS FOR PROTECTIVE
REACTIVITY 0 MEASURES.

Hazardous Ingredients of Materials

Chemical Identity Percent CAS#
NA

ADDITIONAL INGREDIENT INFORMATION (WHMIS NOT CONTROLLED):
MINERAL OIL

Physical Data For Product

PHYSICAL STATE LIQUID
ODOUR AND APPEARANCE COLORLESS TO LIGHT AMBER FLUID, LOW ODOUR
ODOUR THRESHOLD NE
SPECIFIC GRAVITY/DENSITY (g/mL) 0.87 @ 16°C
VAPOUR PRESSURE < 0.01 mm Hg @ 20°C
VAPOUR DENSITY (air=1) > 1
VOLATILITY/VOL(%) NE
SOLUBILITY IN H2O NEGLIGIBLE
EVAPORATION RATE NE
BOILING POINT > 226°C
FREEZING POINT NE
pH NA
COEFFICIENT OF WATER /OIL
DISTRIBUTION NE

SHIPPING INFORMATION

THIS PRODUCT IS NOT TDG REGULATED.

NA - NOT APPLICABLE

NE - NOT ESTABLISHED



Material Safety Data Sheet

Printed: 8/26/03

PQ AA 20

Fire and Explosion Hazard of Product

CONDITIONS OF FLAMMABILITY . . . . HANDLE AWAY FROM ALL SOURCES OF IGNITION MEANS
OF EXTINCTION . . . . . USE DRY CHEMICALS, CARBON DIOXIDE, FOAM OR
WATER FOG TREAT AS AN OIL FIRE

FLASHPOINT AND METHOD OF
DETERMINATION..... 215°C PER ASTM D 92 (COC)
UPPER EXPLOSION LIMIT
(% BY VOLUME)..... NE
LOWER EXPLOSION LIMIT
(% BY VOLUME)..... NE
AUTO-IGNITION TEMPERATURE . . . . . NE
FLAMMABILITY CLASSIFICATION . . . . . NE
HAZARDOUS COMBUSTION PRODUCTS . . . . . OXIDES OF CARBON
EXPLOSION DATA . . . . . NE
SENSITIVITY TO STATIC
DISCHARGE..... NE

Reactivity Data

CHEMICAL STABILITY . . . . . STABLE
INCOMPATIBLE MATERIALS . . . . . STRONG OXIDIZERS
CONDITIONS OF REACTIVITY . . . . . NE
HAZARDOUS DECOMPOSITION
PRODUCTS..... NE

Health Hazard Information

\*\* Based on Component Information \*\*

PRIMARY HEALTH HAZARDS: . . . . . NONE AT NORMAL USE TEMPERATURES
ROUTES OF ENTRY
SKIN CONTACT..... NOT AN IRRITANT
SKIN ABSORPTION..... NE
EYE..... MAY CAUSE SLIGHT IRRITATION.
INHALATION..... NE
INGESTION..... NE

ACUTE OR CHRONIC OVER EXPOSURE EFFECTS:

NE

IRRITANCY OF PRODUCT / SENSITIZATION TO PRODUCT:

NA

CARCINOGENICITY/TERATOGENICITY/MUTAGENICITY/REPRODUCTIVE TOXICITY:

TO THE BEST OF ANDEROL CANADA KNOWLEDGE, THIS MATERIAL DOES NOT CONTAIN ANY
CHEMICALS IN REPORTABLE AMOUNTS LISTED AS CARCINOGENS, TERATOGENS, MUTAGENS,
OR REPRODUCTIVE TOXINS, AS OF THE DATE HEREOF.

Preventive Measures

PERSONAL PROTECTIVE EQUIPMENT . . . . . USE IMPERVIOUS GLOVES. WEAR SAFETY GLASS.
IF TLV OF THE PRODUCT OR ANY COMPONENTS
IS EXCEEDED, AN APPROVED RESPIRATOR IS
ADVISED.
SPECIFIC ENGINEERING CONTROLS .. LOCAL EXHAUST IS RECOMMENDED

NA - NOT APPLICABLE

NE - NOT ESTABLISHED



Material Safety Data Sheet

Printed: 8/26/03

PQ AA 20

LEAK AND SPILL PROCEDURES ..... SOAK UP WITH AN ABSORBENT MATERIAL.  
WASTE DISPOSAL ..... CONSULT FEDERAL OR LOCAL AUTHORITIES FOR  
PROPER DISPOSAL PROCEDURE.  
HANDLING PROCEDURES AND ..... WASH BEFORE EATING, DRINKING, USING TOBACCO  
EQUIPMENT ..... PRODUCTS OR REST ROOMS  
STORAGE REQUIREMENTS ..... KEEP IN A CLOSED, LABELED CONTAINER IN A  
VENTILATED AREA.

=====  
First Aid Measures  
=====

FLUSH EYES WITH LARGE AMOUNT OF WATER FOR 15 MINUTES WHILE HOLDING  
EYELIDS OPEN. IF ANY IRRITATION OCCURS OR PERSISTS, SEEK MEDICAL  
ATTENTION.  
WASH SKIN WITH WATER AND SOAP.  
INGESTION: DO NOT GIVE LIQUIDS IF PERSON IS UNCONSCIOUS OR VERY DROWSY.  
OTHERWISE GIVE 2 GLASSES OF WATER OR MILK AND SEEK IMMEDIATE MEDICAL  
ATTENTION.  
INHALATION: IF AFFECTED, REMOVE PERSON TO FRESH AIR IMMEDIATELY. IF  
BREATHING HAS STOPPED, APPLY ARTIFICIAL RESPIRATION AND ADMINISTER OXYGEN  
IF NECESSARY. SEEK MEDICAL ATTENTION.

=====  
Preparation Date of Material Safety Data Sheet  
=====

PREPARED BY ..... PRODUCT SAFETY AND ENVIRONMENT DEPARTMENT  
PHONE NUMBER OF PREPARER ..... 905-827-9087  
DATE PREPARED ..... 03/13/02  
DATE REVISED..... 03/13/02

MINIMUM CONTACT WITH THIS AND ALL CHEMICALS IS RECOMMENDED AS A GOOD GENERAL POLICY TO FOLLOW.

THE INFORMATION PRESENTED HEREIN HAS BEEN COMPILED FROM SOURCES CONSIDERED TO BE  
DEPENDABLE AND IS ACCURATE TO THE BEST OF OUR KNOWLEDGE. HOWEVER, SINCE DATA, SAFETY  
STANDARDS, AND GOVERNMENT REGULATIONS ARE SUBJECT TO CHANGE AND THE CONDITIONS OF  
HANDLING AND USE, OR MISUSE ARE BEYOND OUR CONTROL, ANDEROL  
CANADA MAKES NO WARRANTY EXPRESSED OR IMPLIED, WITH RESPECT TO COMPLETENESS OR  
CONTINUING ACCURACY OF THE INFORMATION CONTAINED HEREIN AND DISCLAIMS ALL  
LIABILITY FOR RELIANCE THEREON. USER SHOULD SATISFY HIMSELF THAT HE HAS ALL  
CURRENT DATA RELEVANT TO HIS PARTICULAR USE.

NA - NOT APPLICABLE

NE - NOT ESTABLISHED