

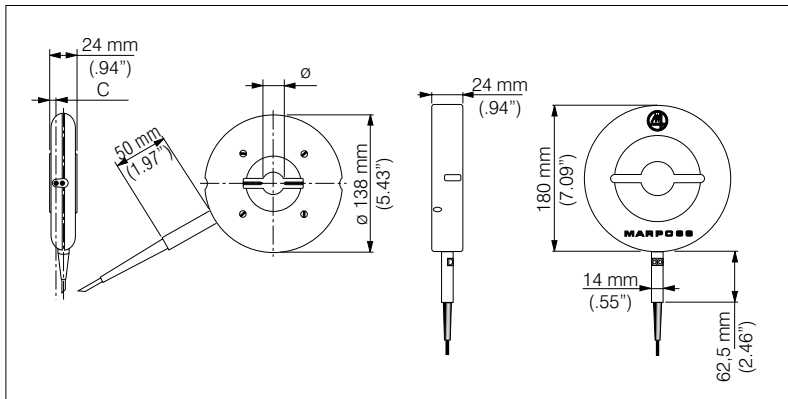

MANUAL RING

- Electronic manual ring gauge with full-bridge (LVDT) transducer for checking outside diameters of shaft and pin type parts in the range 4 to 100 mm (.16" to 3.98"). Particularly suitable to perform measurements close to a shoulder.
- It is composed of a ring body and standard interchangeable nose-piece; within its range of use each ring is completely retoolable by changing the nosepiece and the contacts.
- Accurate, rugged and reliable, needs no maintenance and has practically no operating costs.
- Thanks to its outstanding qualities, it can be used in the most difficult working conditions without any affect to its technical characteristics.
- It can be used both directly on the workpiece and as a simple fixture using the optional support.
- The measurement value can be displayed on the TESTAR E18, E4, E4N and, through the Gage Box data acquisition system, on the E9066s Industrial PC.



The M4 comes with various C measurement point distance values that allow great flexibility in the measurement position. The C dimension comes in 2,5 mm for close to flange measurements, in 6 mm for normal measurements and in 12 mm for bottom measurements.

TECHNICAL CHARACTERISTICS

RETOOLING RANGE (mm)	4 - 50	50 - 100
REPEATABILITY	$\leq 1 \mu\text{m}$	
THERMAL DRIFT	$\leq 0.15 \mu\text{m}/^\circ\text{C}$	$\leq 0.7 \mu\text{m}/^\circ\text{C}$
MEASURING FORCE	$1.2 \text{ N} \pm 10\%$	$0.70 \text{ N} \pm 30\%$
WEIGHT	$0.7 \div 0.8 \text{ kg}$	$1.8 \div 2 \text{ kg}$
CABLE LENGTH	1.8 m	
CONNECTOR TYPE	<i>Lumberg S3 (DIN 41524) or SV50/6 (DIN 45322)</i>	

N.B. The above measuring range cannot be covered with only one nosepiece, but a dedicated nosepiece is necessary for each diameter to be measured (SEE HOW TO ORDER A FINISHED RING).



HOW TO ORDER A FINISHED RING

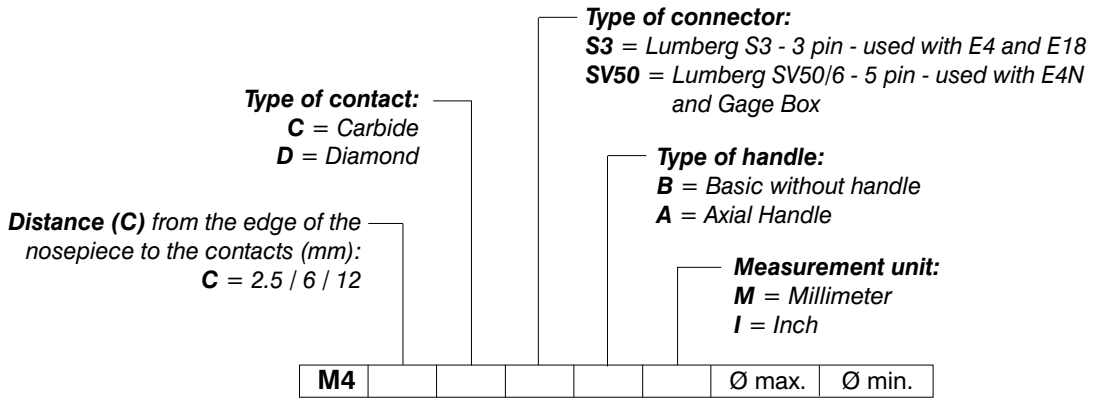

EXAMPLE: Need to order an M4 with C=2.5 mm, carbide contacts, E4N connector, without handle, max. ø 38.735 mm (1.525 inch), min. ø 38.710 mm (1.524 inch).

M4	2.5	C	SV50	B	M	38.735	38.710
-----------	-----	---	------	---	---	--------	--------

COMPONENTS AND ACCESSORIES

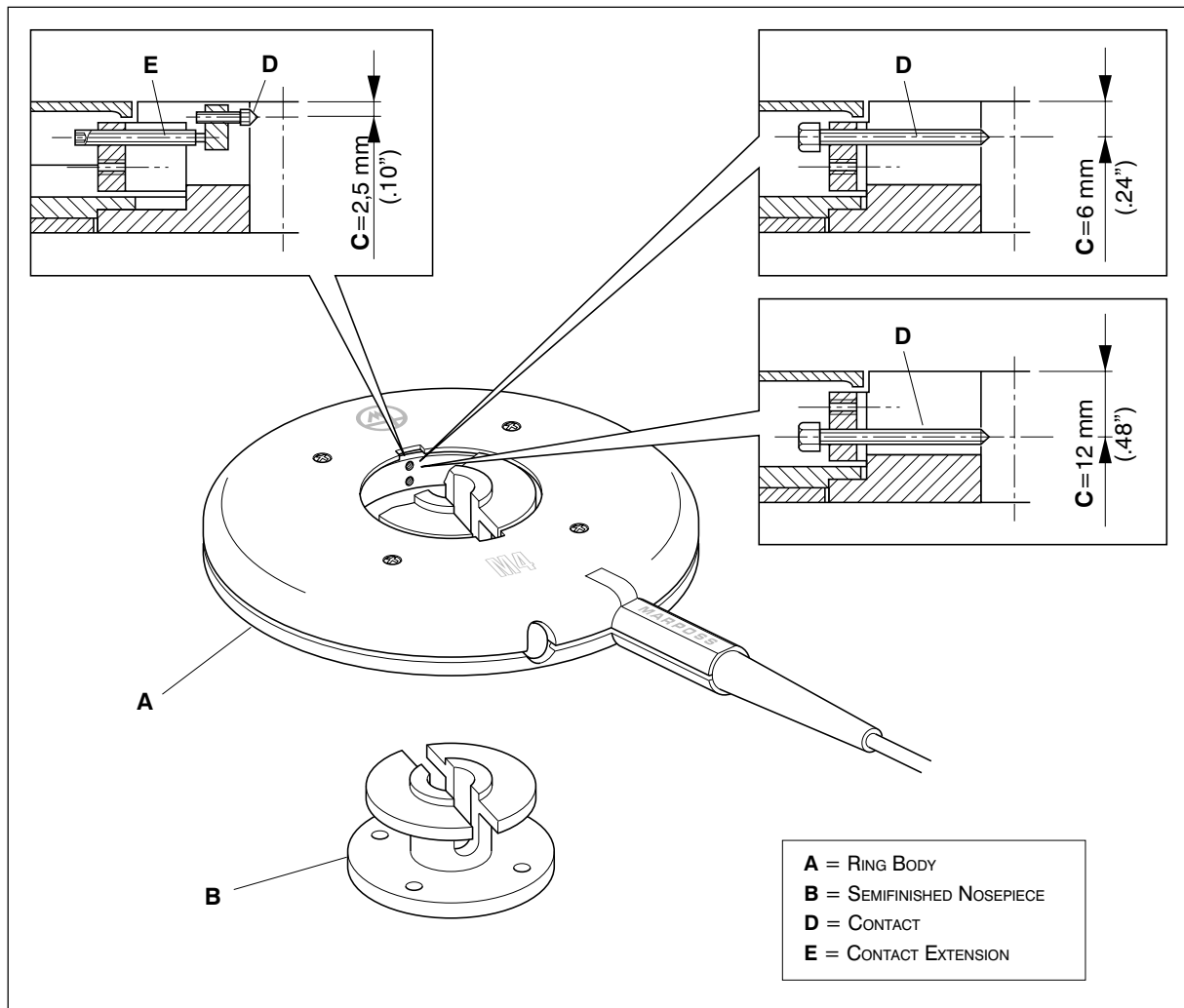

RETOOLING RANGE		C		(A) RING BODY			
				ORDER CODE	CABLE LENGTH		CONNECTOR TYPE
(mm)	(inch)	(mm)	(inch)		(m)	(inch)	
4 - 50	.16" - 1.97"	2.5 / 6 / 12	.10" / .24" / .48"	3708602200	1.8	70.86"	LUMBERG S3
				3708602210	1.8	70.86"	LUMBERG SV50/6
50 -100	1.97" - 3.94"	2.5 / 6 / 12	.10" / .24" / .48"	3708602401	1.8	70.86"	LUMBERG S3
				3708602411	1.8	70.86"	LUMBERG SV50/6

RETOOLING RANGE		C		(B) SEMIFINISHED NOSEPIECES	(D) CONTACTS		(E) CONTACT EXTENSIONS
				ORDER CODE	ORDER CODE		ORDER CODE
(mm)	(inch)	(mm)	(inch)		CARBIDE	DIAMOND	
4 - 12	.16" - .47"	6 / 12	.24" / .47"	1408602014	3390860201	3390860205	
		2.5	.10"	1408602013	3390860210	3390860215	1108602201
12 - 25	.47" - .98"	6 / 12	.24" / .47"	1408602015	3390860201	3390860205	
		2.5	.10"	1408602015	3390860210 (*)	3390860215 (*)	1108602201
25 - 30	.98" - 1.18"	6 / 12	.24" / .47"	1408602015	3390860202	3391342601	
		2.5	.10"		3390860212	3390860217	1108602201
30 - 50	1.18" - 1.97"	6 / 12	.24" / .47"	1408602016	3390860202	3391342601	
		2.5	.10"		3390860212	3390860217	1108602201
50 - 90	1.97" - 3.54"	6 / 12	.24" / .47"		3390860201	3390860205	
		2.5	.10"		3390860210 (***)	3390860215 (***)	1108602201
90 - 100	3.54" - 3.94"	6 / 12	.24" / .47"		3390860212 (****)	3390860217 (****)	1108602201
		2.5	.10"		3390860202	3391342601	
					3390860212	3390860217	1108602201

NOTE: Quantity for order code = 1pcs; Not available where not indicated.

(*) Only for range 12 to 20 mm (.47" to .79")

(**) Only for range 20 to 25 mm (.79" to .98")

(***) Only for range 50 to 85 mm (1.97" to 3.35")

(****) Only for range 85 to 90 mm (3.35" to 3.54")



DESCRIPTION	ORDER CODE
Hex Wrench 1.5 mm	1300725000
Tube Wrench 2.5 mm	1300728000
Tube Wrench 4.0 mm	1300729000
Hex Contact Extension Wrench	1300730000
V for part introduction	1008602207
Axial Handle Transformation Kit (Range 4 to 50 mm)	2908602000
Axial Handle Transformation Kit (Range 50 to 100 mm)	2908602400
Stand	1300610000
Interface Cable Lumberg S3 to SV50/6	6738536000
Interface Cable Lumberg SV50/6 to S3	6735832000
Extension Cable with Lumberg SV50/6 (2 m)	6735932015
Extension Cable with Lumberg SV50/6 (5 m)	6735932016
Extension Cable with Lumberg SV50/6 (10 m)	6735932017
User Manual (Range 4 to 50 mm)	D0040004X1 (*)
User Manual (Range 50 to 100 mm)	D0040008X1 (*)

(*) X= I (Italian), U (English), D (German), E (Spanish), F (French), J (Japanese), P (Portuguese).

STAND

The Stand (same as M1) is designed to enable the use of the M4 electronic ring gauge as a bench gauge. It can accommodate the M4 range 4 to 50 mm in both versions with radial and axial cable output; the M4 range 50 to 100 mm can be accommodated only in axial cable output version. It is particularly helpful when quantities of work pieces with close tolerances are to be gauged.

