

### PENCIL PROBES LINE

The Red Crown™ pencil probe line developed by TESTAR, a Marposs division, to fulfil quality control requirements in the workshop is available in four variants:

#### Basic line:

A family of 52 standard models covering a measuring range from  $\pm 0,5$  to  $\pm 5$  mm. The pencil probes are supplied with full-bridge (LVDT) or half-bridge (HBT) transducer already calibrated for connection to any TESTAR electronic display units such as E18, E4, E4N, Quick Read Microcolumn and, through the data acquisition systems Easy Box and Gage Box™ to E9066s™ Industrial PC.

#### Compatible line:

A comprehensive list of probes

covering the TESTAR standard measuring ranges with appropriate electrical connector and calibrated to comply with your existing electronic display unit.

#### Unplugged line:

The 52 standard models of the basic line can also be provided without connector. Based on established electrical characteristics supplied with each probe the user can add the necessary connector and perform the appropriate calibration to the electronics in use.

#### Soft touch line:

Pencil probes especially designed with very low measuring force to directly gauge delicate parts such as glass, TV tubes, car windshields and plastic material. These probes can be supplied in basic or

compatible configuration.

Reliability and durability are assured in all models through innovative design and the use of the most suitable materials, developed thanks to TESTAR's extensive experience in the quality control sector.

Red Crown pencil probes assure precision measurements, even below one micron, and contribute to the quality of measurement data.

Red Crown™ product line offers:

- Comprehensive product range
- High quality and precision
- Competitive price
- Short delivery
- Durability

**Red Crown™ pencil probes - the easiest choice to gauge your part.**

### QUALITY GUARANTEE

TESTAR's technical team has over thirty years of experience in the manufacture and use of pencil probes for its own applications and those of third parties. Knowledge of the manufacturing workshop environment was essential to the development of the Red Crown product line.

TESTAR, which has ISO 9000 certification, manufactures every pencil probe to the strictest quality standards, on the basis of its own experience and in accordance with the quality that a measuring instrument must provide.

The Red Crown product is 100% tested, following internationally recognized procedures and using computerized equipment which define the basic product parameters.

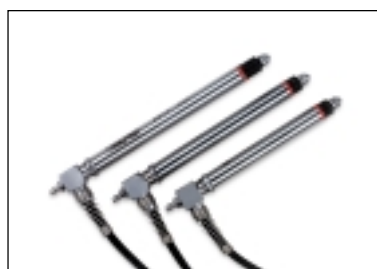

## THE PRODUCT

TESTAR experience has allowed the development of the Red Crown product line, a product with innovative features that satisfies the most demanding market standards.

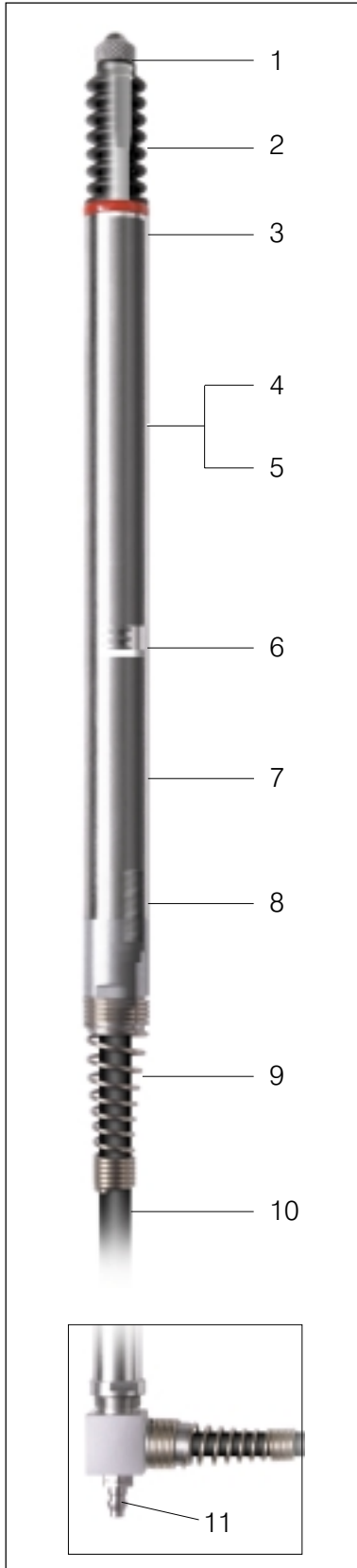

Red Crown pencil probes consist of the following basic parts:

- 1 - **Contact.** Interchangeable ( M2,5 or 4-48 UNF thread - standard model made of tungsten carbide, R= 1,5 mm).  
A wide range of optional contacts is available, to suit all specific measuring requirements. The “soft touch” models are typically supplied with interchangeable nylon contact to prevent surface damage.
- 2 - **Gaiter.** It is made of rubber (Fluoreolastomer) and protects the internal mechanical parts from dust or liquids (IP65).  
It allows the product to function in the workshop, even in the harshest conditions. The “soft touch” models are provided without gaiter for consistent low measuring force.
- 3 - **Pencil probe body.** The stainless steel body has a hardened surface, to prevent damage to mechanical sliding parts in the event of high tightening torques.  
The entire range of pencil probes includes versions with an external body diameter of both 8h6 mm and 3/8”.
- 4 - **Guide system.** Mounted on ball bearings, guaranteeing optimum sliding movement of the mechanical parts.
- 5 - **Anti-rotation feature.** Facilitates contact assembly/disassembly.
- 6 - **Spring.** Determines the measuring force with which the contact touches the workpiece.  
In addition to the standard spring normally supplied, there is a wide range of optional springs, for a greater or lower measuring force. The “soft touch” models are provided with special spring type to allow low measuring force (0,30 N at electrical zero with horizontal probe axis).
- 7 - **Transducer.** The transducer is made using high tech materials and production processes, which guarantee great precision. It is available in two configurations, full-bridge (LVDT) and half-bridge (HBT), allowing customization of the pencil probes to suit any electronic system on the market.
- 8 - **Pre-travel adjustment.** This device allows optimum adjustment of tangential interference with the workpiece to be checked. Pre-travel adjustment extends the life of the sliding parts inside the pencil probe.
- 9 - **Cable spring.** Always present , the cable spring guarantees an optimum cable curve radius, preventing damage.
- 10 - **Cable.** The 2 meters cable (EMC standards - directive 89/336/EEC) is highly resistant to tears and is covered with a sheath made of special material highly resistant to coolants. The cable outlet may be axial or radial. Extensions of various lengths are also available.
- 11 - **Pneumatic push - Vacuum retract.** Some models can be fitted with a manual or automatic pneumatic device to retract the contact (vacuum retract) or to move the contact to the measuring position (pneumatic push).  
These functions are particularly useful for automatic applications. The “soft touch” models are designed to guarantee a tip force at electrical zero of 0,18 N.

# EXAMPLES OF APPLICATIONS

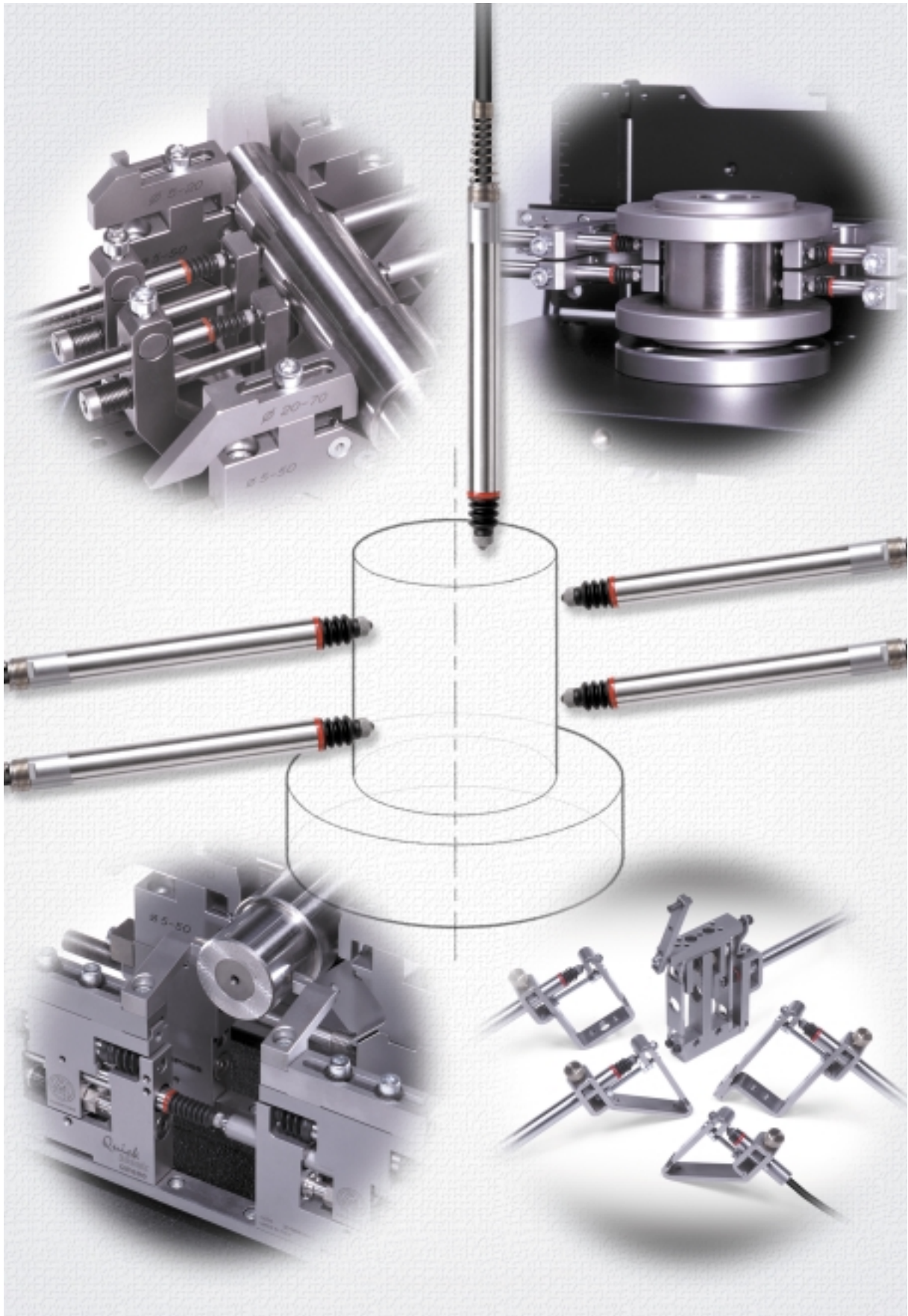

TRANSDUCERS AND MEASUREMENT TRANSMISSIONS



# THE BASIC LINE

The basic Red Crown product line includes 52 models to satisfy the various market needs.

## TECHNICAL SPECIFICATIONS / ORDER CODES

### Mechanical specifications

DESCRIPTION	MEASURING RANGE									
	± 0,5 mm		± 1mm				± 2,5mm		± 5mm	
	Standard		Standard	Pneum. Push	Long Range (LR) Standard	P. Push	Standard	Pneum. Push	Standard	Pneum. Push
Pre-travel at electrical zero (mm)	0,6/0,7		1,1/1,2				2,6/2,7		5,1/5,2	
Overtravel from electrical zero (mm)	≥ 0,65		≥ 1,5				≥ 3		≥ 5,1	
Pre-travel adjustment	Yes		Yes				Yes		Yes	
Pneumatic Push (PP)	-		VR(*)	PP	VR(*)	PP	-	VR(*)	PP	-
Vacuum Retract (VR)	-		-				-			
Operating pressure	bar	-	-	0,4+1	-	0,5+1	-	0,4+1	-	0,4+1
	psi	-	-	6+14,5	-	7,3+14,5	-	6+14,5	-	6+14,5
Standard spring strength (N/mm ± 15%)	0,17		0,14		0,08	0,1	0,02	0,08	0,03	0,06
Tip force at electrical zero (N ± 25%)	1		0,7		0,8+2,5	0,7	0,5+2	0,7	0,6+2,3	0,7
Guide system	ball bearing		ball bearing				ball bearing		ball bearing	
Repeatability (σ x 2,77) (μm)	≤ 0,15		≤ 0,15				≤ 0,2		≤ 0,4	
Degree of protection CEI/IEC 529	IP65		IP65				IP65		IP65	
Standard contact (R...mm)	1,5		1,5				1,5		1,5	
Optional contacts	Yes		Yes				Yes		Yes	
Linearity error (μm)	≤ 3 (0,3%)		≤ 5 (0,25%)				≤ 25 (0,5%)		≤ 50 (0,5%)	
Thermal drift at zero (μm/°C)	≤ 0,25		≤ 0,25				≤ 0,25		≤ 0,5	
Operating temperature (°C)	-10 +65		-10 +65				-10 +65		-10 +65	
Standard gaiter	Fluoroelastomer		Fluoroelastomer				Fluoroelastomer		Fluoroelastomer	
Std. connector (DIN 45322) Lumberg	SV50/6		SV50/6				SV50/6		SV50/6	
Cable length (m)	2		2				2		2	

(\*) The Vacuum Retract function (contact pneumatic retraction) can be added by using the accessories code 4430245031 or 4430240679. It is also necessary to substitute the standard springs with the following ones:

±1 VR	spring 1024099711
±1 LR	spring 1024099735
±2,5 VR	spring 1024099721
±5 VR	spring 1024099735 + spring-guide 1024099660

### Full-bridge (LVDT) electrical specifications

Trade name	F05		F10				F25				F50																
		FR05		FR10	FP10	FR11	FP11		FR25	FP25		FR50	FP50														
Calibration frequency (KHz)	7,5		7,5				7,5				7,5																
Calibrated at	3,5V RMS with load 1MΩ // 360 pF																										
Max. current (mA RMS)	9		9				9				9																
I/O phase shift	≤ 10°		≤ 10°				≤ 10°				≤ 10°																
Sensitivity (mV/V/mm)	230 ±1%		230 ±1%				115 ±1%				115 ±1%																
Cable outlet	axial	∅ 3/8"	∅ 3/8"	∅ 3/8"	∅ 3/8"	∅ 3/8"	∅ 3/8"	∅ 3/8"	∅ 3/8"	∅ 3/8"	∅ 3/8"	∅ 3/8"	∅ 3/8"	∅ 3/8"													
	radial	∅ 3/8"	∅ 3/8"	∅ 3/8"	∅ 3/8"	∅ 3/8"	∅ 3/8"	∅ 3/8"	∅ 3/8"	∅ 3/8"	∅ 3/8"	∅ 3/8"	∅ 3/8"	∅ 3/8"													
<b>Order Code</b>		3441552000	3441552002	3441552001	3441552003	3441554000	3441554005	3441554001	3441554006	3441554002	3441554007	3441554003	3441554008	3441554004	3441554009	3441556000	3441556003	3441556001	3441556004	3441556002	3441556005	3441558000	3441558003	3441558001	3441558004	3441558002	3441558005

### Half-bridge (HBT) electrical specifications

Trade name	H05		H10				H25				H50																
		HR05		HR10	HP10	HR11	HP11		HR25	HP25		HR50	HP50														
Calibration frequency (KHz)	7,5		7,5				7,5				7,5																
Calibrated at	3,5V RMS with load 2 KΩ ± 0,1%																										
Max. current (mA RMS)	5		5				5				5																
I/O phase shift	≤ 5°		≤ 5°				≤ 5°				≤ 5°																
Sensitivity (mV/V/mm)	73,75 ±1%		73,75 ±1%				36,9 ±1%				29,5 ±1%																
Cable outlet	axial	∅ 3/8"	∅ 3/8"	∅ 3/8"	∅ 3/8"	∅ 3/8"	∅ 3/8"	∅ 3/8"	∅ 3/8"	∅ 3/8"	∅ 3/8"	∅ 3/8"	∅ 3/8"	∅ 3/8"													
	radial	∅ 3/8"	∅ 3/8"	∅ 3/8"	∅ 3/8"	∅ 3/8"	∅ 3/8"	∅ 3/8"	∅ 3/8"	∅ 3/8"	∅ 3/8"	∅ 3/8"	∅ 3/8"	∅ 3/8"													
<b>Order Code</b>		3441551000	3441551002	3441551001	3441551003	3441553000	3441553005	3441553001	3441553006	3441553002	3441553007	3441553003	3441553008	3441553004	3441553009	3441555000	3441555003	3441555001	3441555004	3441555002	3441555005	3441557000	3441557003	3441557001	3441557004	3441557002	3441557005

Note : The User manual is included in the package.

## DIMENSIONS (mm)

The clamping diameter of all versions is available both as 8h6 mm or 3/8".

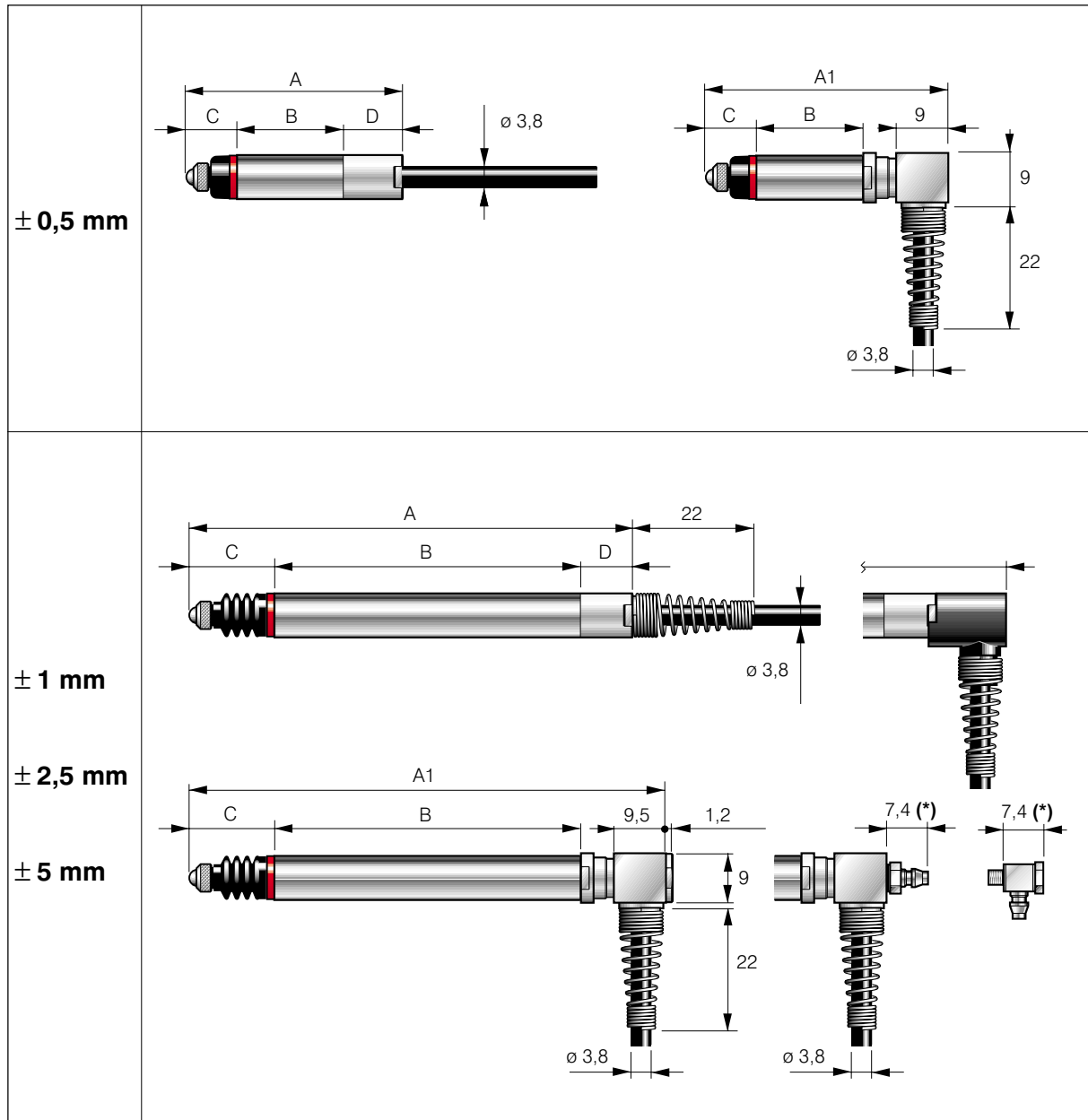

DIMENSIONS	MEASURING RANGE								
	± 0,5 mm	± 1 mm			± 2,5 mm		± 5 mm		
	Standard	Standard	Pneum. Push	Long Range (LR)		Standard	Pneum. Push	Standard	Pneum. Push
			Standard	Pneum. Push					
A	39,2	80	-	-	-	92,5	-	118	-
A1	42,8	86	86	116,6	116,6	98,9	98,9	124	124
A2	-	92,5	-	-	-	105	-	130,5	-
B	19,2	57	57	76	76	68	68	84,5	84,5
C	9,2	13,5	13,5	25	25	15	15	21	21
D	10,8	9,5	-	-	-	9,5	-	12,5	-

(\*) For pneumatic version only.

(\*\*) Right cable adapter is always supplied with the probes with axial cable outlet.

A / A1 / A2 / C refer to the electrical zero



## COMPATIBLE LINE

TESTAR has developed a number of Red Crown models with the required connector and calibration, ready to be used as replacement of non-TESTAR probes. This allows the user to take advantage of the latest technology designed in the Red Crown product without the need to replace the existing electronic unit.

For mechanical specifications and dimensions of these probes see the corresponding model in the basic line. This line is in continuous development and you can find the latest list of products with order codes by visiting our web site [www.testar.com](http://www.testar.com)

BASIC MODELS			MEASURING RANGE									
			± 0,5 mm		± 1 mm		± 1 mm LONG RANGE	± 2,5 mm		± 5 mm		
MANUFACTURER	TRANSD. TYPE	Ø	H05	HR5	H10	HR10	HR11	H25	HR25	H50	HR50	
TESA	HALF-BRIDGE (HBT)	8	3441561000	3441561001	3441561002	3441561003 (*)	3441561005 (*)	3441561007	3441561008 (*)	3441561010	3441561011 (*)	
MERCER		8	3441564000	3441564001	3441564002	3441564003 (*)	3441564005 (*)	3441564007	3441564008 (*)	3441564010	3441564011 (*)	
METEM		8	3441569000	3441569001	3441569002	3441569003 (*)	3441569005 (*)	3441569007	3441569008 (*)	3441569010	3441569011 (*)	
METREL		8	3441563000	3441563001	3441563002	3441563003 (*)	3441563005 (*)	3441563007	3441563008 (*)	-	-	
MAHR-FEINPRUEF		8	3441567000	3441567001	3441567002	3441567003 (*)	3441567005 (*)	3441567007	3441567008 (*)	3441567010	3441567011 (*)	
NOVIBRA		8	-	-	3441568003	-	-	-	-	-	-	-
MACHSIZE-SYSTEM E		8	3441562009	3441562010	3441562008	3441562011	3441562013	-	-	-	-	
AIR GAGE		3/8"	3441562000	3441562001	3441562002	3441562003 (*)	-	3441562005	3441562006 (*)	-	-	
MANUFACTURER	TRANSD. TYPE	Ø	F05	FR5	F10	FR10	FR11	F25	FR25	F50	FR50	
ETAMIC (ZDB)	FULL-BRIDGE (LVDT)	8	3441565009	3441565010	3441565006	3441565011	3441565013	3441565007	3441565015	3441565008	3441565017	

(\*) The Vacuum Retract function (contact pneumatic retraction) can be added by using the accessories code 4430245031 or 4430240679. It is also necessary to substitute the standard springs with the one reported in the table on page 4.

PNEUMATIC PUSH MODELS			MEASURING RANGE			
			± 1 mm	± 1 mm LONG RANGE	± 2,5 mm	± 5 mm
MANUFACTURER	TRANSD. TYPE	Ø	HP10	HP11	HP25	HP50
TESA	HALF-BRIDGE (HBT)	8	3441561004	3441561006	3441561009	3441561012
MERCER		8	3441564004	3441564006	3441564009	3441564012
METEM		8	3441569004	3441569006	3441569009	3441569012
METREL		8	3441563004	3441563006	3441563009	-
MAHR-FEINPRUEF		8	3441567004	3441567006	3441567009	3441567012
MACHSIZE-SYSTEM E		8	3441562012	3441562014	-	-
AIR GAGE		3/8"	3441562004	-	3441562007	-
MANUFACTURER	TRANSD. TYPE	Ø	FP10	FP11	FP25	FP50
ETAMIC (ZDB)	FULL-BRIDGE (LVDT)	8	3441565012	3441565014	3441565016	3441565018

NOTE: The User manual is included in the package.

## TECHNICAL SPECIFICATIONS / ORDER CODES

### Mechanical specifications

DESCRIPTION	MEASURING RANGE									
	± 0,5 mm		± 1mm				± 2,5mm		± 5mm	
	Standard		Standard	Pneum. Push	Long Range (LR) Standard	P. Push	Standard	Pneum. Push	Standard	Pneum. Push
Pre-travel at electrical zero (mm)	0,6/0,7		1,1/1,2				2,6/2,7		5,1/5,2	
Overtravel from electrical zero (mm)	≥ 0,65		≥ 1,5				≥ 3		≥ 5,1	
Pre-travel adjustment	Yes		Yes				Yes		Yes	
Pneumatic Push (PP)	-		VR(*)	PP	VR(*)	PP	-	VR(*)	PP	-
Vacuum Retract (VR)	-		-				-		-	
Operating pressure	bar psi		0,4+1 6+14,5		0,5+1 7,3+14,5		0,4+1 6+14,5		0,4+1 6+14,5	
Standard spring strength (N/mm ± 15%)	0,17		0,14		0,08		0,08		0,06	
Tip force at electrical zero (N ± 25%)	1		0,75		0,8+2,5		0,7		0,5+2	
Guide system	ball bearing		ball bearing				ball bearing		ball bearing	
Repeatability (σ x 2,77) (µm)	≤ 0,15		≤ 0,15				≤ 0,2		≤ 0,4	
Degree of protection CEI/IEC 529	IP65		IP65				IP65		IP65	
Standard contact (R...mm)	1,5		1,5				1,5		1,5	
Optional contacts	Yes		Yes				Yes		Yes	
Thermal drift at zero (µm/°C)	≤ 0,25		≤ 0,25				≤ 0,25		≤ 0,5	
Operating temperature (°C)	-10 +65		-10 +65				-10 +65		-10 +65	
Standard gaiter	Fluoroelastomer		Fluoroelastomer				Fluoroelastomer		Fluoroelastomer	
Cable length (m)	3,5		3,5				3,5		3,5	

(\*) The Vacuum Retract function (contact pneumatic retraction) can be added by using the accessories code 4430245031 or 4430240679. It is also necessary to substitute the standard springs with the one reported in the table on page 4.

### Full-bridge (LVDT) electrical specifications

Trade name	F05		F10		F25		F50																			
	FR05		FR10	FP10	FR11	FP11	FR25	FP25																		
Sensitivity (mV/mm/V)	152+ 248		217+ 228		112+ 120		114+ 122																			
Linearity error (µm)	≤ 2,7 (0,3%)		≤ 3,6 (0,2%)		≤ 15 (0,3%)		≤ 38 (0,4%)																			
Energising frequency range (kHz)	2+ 20		2+ 20		2+ 20		4+ 9																			
Energising Voltage range (Vrms)	1+ 7		1+ 7		1+ 7		1+ 7																			
Energising current range (mA/V)	5,9+ 0,8		5,4+ 0,6		3,2+ 0,5		2,6+ 1,5																			
I/O phase shift (°)	38+ -1,2		13+ -7		10+ -8		-3,3+ -8,4																			
Zero phase frequency (kHz)	17,5		7,5		6		-																			
Calibration load (kΩ)	100		100		100		100																			
Test frequency (kHz)	7,5		7,5		7,5		7,5																			
Test Voltage (Vrms)	3,54		3,54		3,54		3,54																			
Test load	1 MΩ/360 pF		1 MΩ/360 pF		1 MΩ/360 pF		1 MΩ/360 pF																			
Sensitivity at test conditions (mV/mm/V)	240 ±5%		239 ±5%		118 ±5%		116 ±5%																			
Linearity at test conditions (µm)	≤ 3 (0,3%)		≤ 2 (0,1%)		≤ 25 (0,5%)		≤ 50 (0,5%)																			
Energising current at test conditions (mA/V)	2		2		1		2																			
I/O phase shift at test conditions (°)	10±2		1,5±1		2±2		7±2																			
Cable outlet	axial radial		axial radial		axial radial		axial radial																			
Order Code	3441566002	3441566008	3441566007	3441566009	3441566023	3441566028	3441566024	3441566029	3441566025	3441566030	3441566026	3441566031	3441566027	3441566032	3441566039	3441566042	3441566040	3441566043	3441566041	3441566044	3441566051	3441566054	3441566052	3441566055	3441566053	3441566056

### Half-bridge (HBT) electrical specifications

Trade name	H05		H10		H25		H50																			
	HR05		HR10	HP10	HR11	HP11	HR25	HP25																		
Sensitivity (mV/mm/V)	70+ 87		79+ 87		59+ 74		31+ 33																			
Linearity error (µm)	≤ 2,5 (0,3%)		≤ 0,9 (0,05%)		≤ 16,2 (0,3%)		≤ 23 (0,2%)																			
Energising frequency range (kHz)	2+ 20		2+ 20		2+ 20		2+ 20																			
Energising Voltage range (Vrms)	2+ 5		2+ 5		2+ 5		3+ 5																			
Energising current range (mA/V)	1,8+ 0,2		2,9+ 0,4		2,1+ 0,3		1,8+ 0,3																			
I/O phase shift (°)	25+ -17		17+ -14		27+ -19		16+ -11																			
Zero phase frequency (kHz)	7,5		7		7		7																			
Calibration load (kΩ)	1		1		1		1																			
Test frequency (kHz)	7,5		7,5		7,5		7,5																			
Test Voltage (Vrms)	3,54		3,54		3,54		3,54																			
Test load (kΩ)	2		2		2		2																			
Sensitivity at test conditions (mV/mm/V)	91,5 ±5%		89 ±5%		77 ±5%		34,5 ±5%																			
Linearity at test conditions (µm)	≤ 3		≤ 5		≤ 25		≤ 50																			
Energising current at test conditions (mA/V)	0,6		0,6		0,7		0,7																			
I/O phase shift at test conditions (°)	3,5±2		1±2		3±2		1±2																			
Cable outlet	axial radial		axial radial		axial radial		axial radial																			
Order Code	3441566001	3441566005	3441566004	3441566006	3441566003	3441566018	3441566014	3441566019	3441566015	3441566020	3441566016	3441566021	3441566017	3441566022	3441566033	3441566036	3441566034	3441566037	3441566035	3441566038	3441566045	3441566048	3441566046	3441566049	3441566047	3441566050

Note : The User manual is included in the package.



# "SOFT TOUCH" LINE

These models are offered to satisfy some specific measurement requirements where tip force must consistently be kept at a very minimum value. Typical applications include glass, TV tubes, car windshields and generally plastic material as found in the electronics industry (cellular phone shells, computers and printers components etc.)

## TECHNICAL SPECIFICATIONS / ORDER CODES

### Mechanical specifications

DESCRIPTION	MEASURING RANGE														
	± 0,5 mm		± 1mm						± 2,5mm			± 5mm			
	Standard	Standard	Pneumatic Push (*)		Long Range (LR)		Pneumatic Push (*)		Standard	Pneumatic Push (*)		Standard	Pneumatic Push (*)		
Pre-travel at electrical zero (mm)	0,6/0,7		1,1/1,2						2,6/2,7			5,1/5,2			
Overtravel from electrical zero (mm)	≥ 0,65		≥ 1,5		≥ 9		≥ 3			≥ 5,1					
Pre-travel adjustment	Yes		Yes						Yes			Yes			
Pneumatic Push (PP)	-	-	PP	PP	-	PP	PP	-	PP	PP	-	PP	PP		
Vacuum Retract (VR)	-	-	-	VR	-	-	VR	-	-	VR	-	-	VR		
Operating pressure	bar	-	-	0,5+2	0,125+2	-	0,5+2	0,125+2	-	0,5+2	0,125+2	-	0,5+2	0,125+2	
	psi	-	-	7,3+29	1,825+29	-	7,3+29	1,825+29	-	7,3+29	1,825+29	-	7,3+29	1,825+29	
Air Leak Rate (at 1,0 bar) (ml/min)	-	-	<350		-		<350		-	<350		-	<350		
Standard spring strength (N/mm ± 15%)	0,07	-	0,13	0,045	-	0,033	0,014	-	0,033	0,0135	-	0,034	0,0137	-	
Tip force at electrical zero (N ± 30%)	0,29	0,06	0,29	0,18+1,23	0,09+1,41	0,06	0,18	0,12+1,17	0,09+1,41	0,06	0,29	0,18+1,23	0,09+1,41	0,06	0,29
Guide system	ball bearing														
Repeatability (σ x 2,77) (µm)	≤ 0,15	≤ 0,15	≤ 0,15		≤ 0,3		≤ 0,3		≤ 0,2	≤ 0,2		≤ 0,4	≤ 0,4		
Degree of protection CEI/IEC 529	IP50	IP50	IP53	IP50	IP50	IP53	IP50	IP50	IP50	IP53	IP50	IP50	IP53	IP50	
Standard contact (R...mm)	1,5	1,5	1,5		1,5		1,5		1,5	1,5		1,5	1,5		
Optional contacts	Yes	Yes	Yes		Yes		Yes		Yes	Yes		Yes	Yes		
Linearity error (µm)	≤ 3 (0,3%)	≤ 5 (0,25%)	≤ 5 (0,25%)		≤ 5 (0,25%)		≤ 5 (0,25%)		≤ 25 (0,5%)	≤ 25 (0,5%)		≤ 50 (0,5%)	≤ 50 (0,5%)		
Thermal drift at zero (µm/°C)	≤ 0,25	≤ 0,25	≤ 0,25		≤ 0,25		≤ 0,25		≤ 0,25	≤ 0,25		≤ 0,5	≤ 0,5		
Operating temperature (°C)	-10 +65	-10 +65	-10 +65		-10 +65		-10 +65		-10 +65	-10 +65		-10 +65	-10 +65		
Standard gaiter	-	-	-		-		-		-	-		-	-		
Std. connector (DIN 45322) Lumberg	SV50/6	SV50/6	SV50/6		SV50/6		SV50/6		SV50/6	SV50/6		SV50/6	SV50/6		
Cable length (m)	2	2	2		2		2		2	2		2	2		

(\*) The compressed air must be filtered better than 5 µm and must be dry with a dew point of between 2°C and 5°C.

### Full-bridge (LVDT) electrical specifications

Trade name	FS5L	FS10L	F10L	FP10L	FP10L	FP10L	FP10L	FP10L	FP10L	FP10L	FP10L	FP10L	FP10L	FP10L	FP10L	FP10L	FP10L	FP10L	FP10L	FP10L					
Calibration frequency (kHz)	7,5																								
Calibrated at	3,5V RMS with load 1 MOhm 360 pF																								
Max. current (mA RMS)	9																								
I/O phase shift	≤ 10°																								
Sensitivity (mV/V/mm)	230 ± 1%																								
Cable outlet	axial radial																								
Order Code	3441552005	3441554019	3441554017	3441554021	3441554015	3441554023	3441554013	3441554020	3441554018	3441554022	3441554016	3441554024	3441554014	3441556011	3441556008	3441556012	3441556009	3441556013	3441556010	3441558011	3441558008	3441558012	3441558009	3441558013	3441558010

### Half-bridge (HBT) electrical specifications of the version compatible with amplifiers of TESA

Trade name	HS5L	HS10L	HF10L	HP10L	HP10L	HP10L	HP10L	HS11L	HR11L	HP11L	HP11L	HP11L	HP11L	HS25L	HS25L	HP25L	HP25L	HP25L	HP25L	HS50L	HS50L	HP50L	HP50L	HP50L	HP50L
Calibration frequency (kHz)	13		13						13						13										
Calibrated at	3V RMS with load 2 KOhm ± 0,1%																								
Max. current (mA RMS)	2		2						2						2										
I/O phase shift	≤ 2°		≤ 2°						≤ 2°						≤ 3°										
Sensitivity (mV/V/mm)	73,75 ± 0,2%		73,75 ± 0,2%						73,75 ± 0,2%						29,5 ± 0,3%										
Cable outlet	axial radial																								
Order Code	3441561028	3441561031	3441561029	3441561034	3441561026	3441561038	3441561022	3441561021	3441561030	3441561037	3441561027	3441561041	3441561025	3441561032	3441561015	3441561035	3441561016	3441561039	3441561023	3441561033	3441561017	3441561036	3441561018	3441561040	3441561024

Note: The User manual is included in the package.



## DIMENSIONS (mm)

The clamping diameter of all versions is 8h6 mm.

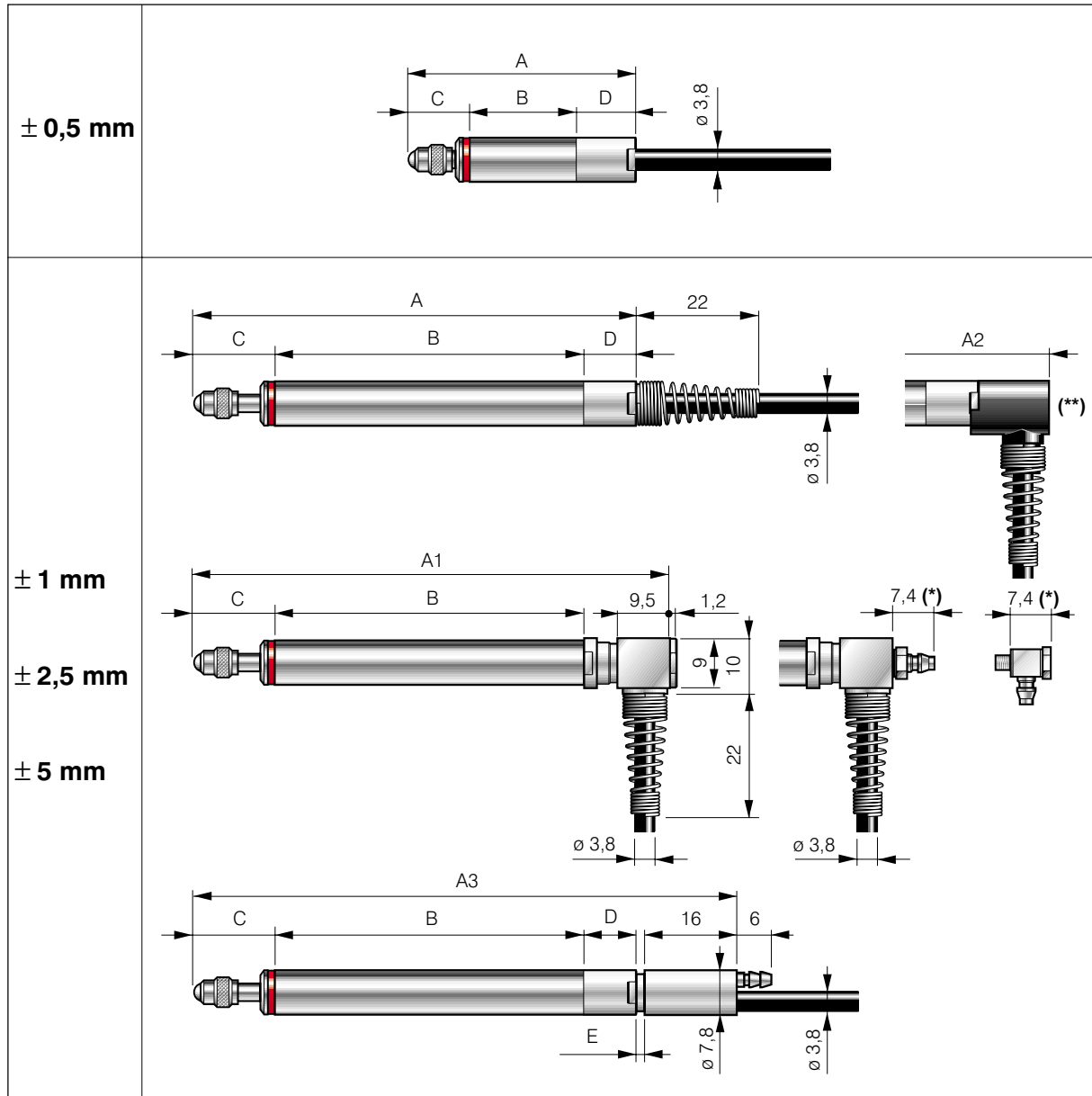

DIMENSIONS	MEASURING RANGE								
	± 0,5 mm	± 1 mm			± 2,5 mm		± 5 mm		
	Standard	Standard	Pneum. Push	Long Range (LR)		Standard	Pneum. Push	Standard	Pneum. Push
			Standard	Pneum. Push					
A	42,15	78,5	-	-	-	91	-	113	-
A1	-	84,5	84,5	111,6	111,6	97,35	97,35	119,45	119,45
A2	-	91	-	-	-	103,5	-	125,5	-
A3	-	-	96	-	122,8	-	108,6	-	130,95
B	19,2	57	57	76	76	68	68	84,5	84,5
C	12,15	12	12	19,9	19,9	13,5	13,5	16	16
D	10,8	9,5	9,5	9,5	9,5	9,5	9,5	12,5	12,5
E	-	-	1,475	-	1,375	-	1,55	-	1,95

(\*) For pneumatic version only.







A / A1 / A2 / A3 / C refer to the electrical zero

(\*\*) Right cable adapter is always supplied with the probes type F10L, F25L, F50L, H10L, H25L, H50L with axial cable outlet.

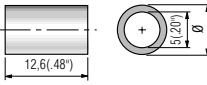

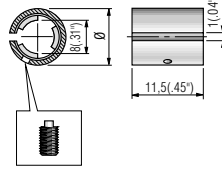
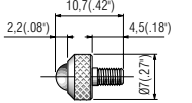
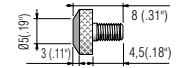
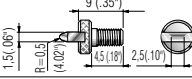
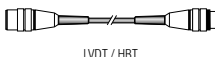
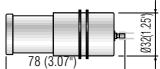
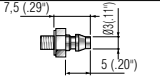
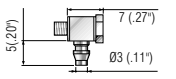
## ACCESSORIES

A wide range of accessories allows to adapt the standard product to satisfy specific application needs.

ACCESSORIES	MEASURING RANGE	± 0.5		± 1		± 1 LR	± 2.5		± 5		± 1 PP	± 1 LR PP	± 2.5 PP	± 5 PP	ORDER CODE
	Cable output	A	R	A	R	R	A	R	A	R	R	R	R	R	
	Body diameter	8 mm	3/8"	8 mm	3/8"	8 mm	3/8"	8 mm	3/8"	8 mm	3/8"	8 mm	3/8"	8 mm	
	Spring 0,4 N														1024099711
	Spring 1 N														1024099712
	Spring 2 N														1024099713
	Spring 2,5 N														1024099714
	Spring 0,4 N														1024099721
	Spring 1 N														1024099722
	Spring 2 N														1024099723
	Spring 2,5 N														1024099724
	Spring 0,4 N (*)						X	X							1024099731
	Spring 1 N														1024099732
	Spring 2 N						Y	Y							1024099733
	Spring 2,5 N														1024099734
	Spring 0,35 N														1024099735
	Spring 0,4 N														1024099530
	Spring 2 N														1024099743
	Spring 2,5 N														1024099744
Spring 0,4 N														1024099751	
Spring 2 N														1024099753	
Spring 2,5 N														1024099754	
	Spring-guide														1024099660
	Double ended wrench Ch. 7/8 (thickness 1,5 mm)														1320709000
	Bushing outside ø10 mm														1019826001
	Bushing outside ø3/8"														1019826002
	Dowel M3x10														1024099760
	Dowel 4-40 UNC x.375"														1024099761
	Contact ø 5 mm / M 2,5														3392409910
	Contact ø 5 mm / 4-48 UNF														3392409911
	Flat contact M 2,5														3392409912
	Flat contact 4-48UNF														3392409913
	Cut contact M 2,5														3392409914
	Cut contact 4-48UNF														3392409915
	Cable extension 2 m														6735932015
	Cable extension 5 m														6735932016
	Cable extension 10 m														6735932017
	Vacuum pump + L=1 m tubing														4717008002
	Axial air adaptor														4430245031
	Radial air adaptor														4430240679
	Adaptor for cable protection spring														1024099765
	Adaptor for cable protection spring														1024099766
	Cable protection spring (2 m)														1090221011

X For FR 11 and HR 11 versions, the value is 0,2 N

Y For FR 11 and HR 11 versions, the value is 1 N

LR Long Range

PP Pneum. Push

A Axial R Radial

(\*) Only for Soft Touch Models

Note: for contact extension see Quick Set section, par. 4.3 CONTACT EXTENSIONS

## REPAIRABILITY

Red Crown pencil probes were designed to satisfy the increasing demand for products easily repairable at low cost.

The use of Red Crown probes makes it possible, offering the following advantages:

- Extended average product life
- Reduced maintenance costs
- Rapid repairs, limiting the number of spare probes

## PROCESS CONTROL

Red Crown mechanical and electronic component manufacturing lines are automated, guaranteeing constant quality.

Particular attention is paid to the inspection of the basic quality parameters, such as:

### • Accuracy

The accuracy of a measuring instrument is its ability to provide measurements which are close to a true value. An accuracy error in a measuring instrument is a systematic indication error.

#### - Sensitivity error

The part of the accuracy error proportional to the position of the measurement range. The sensitivity of a measuring instrument is defined as the variation in the response divided by the corresponding variation in the input signal. Expressed as a percentage (%).

#### - Linearity error

The part of the accuracy error remaining after subtraction of the sensitivity error. Expressed in microns or as a full scale percentage.

### • Repeatability

A measuring instrument's repeatability is its ability to supply values which are very close to one another when it is applied to the same workpiece under the same controlled conditions. Expressed in microns.

### • Measuring force

The force applied to the workpiece by the probe contact in the meas-

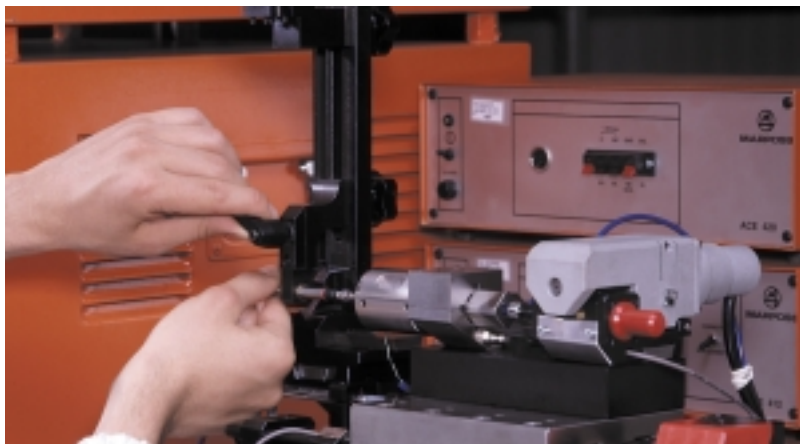
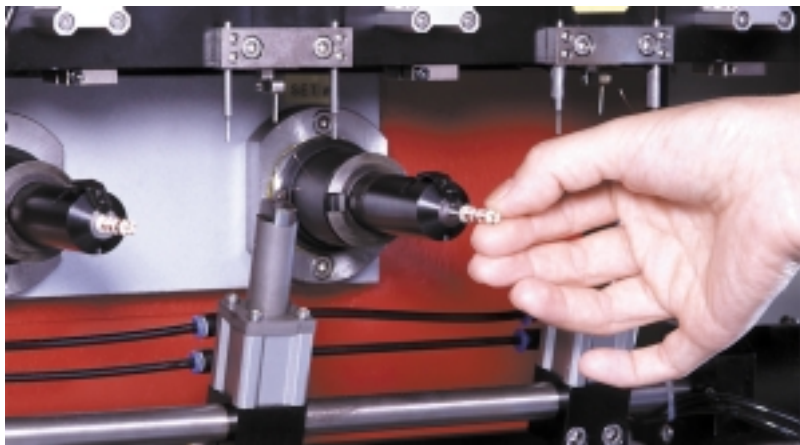

uring condition. The specified force is stated at electrical zero with the probe in a horizontal position. Expressed in Newtons.

### • Pre-travel adjustment

Determines the optimum contact working position according to the size of the workpiece. Correctly adjusted, this prevents damage due to impact with the workpiece and extends the life of the pencil probe.

### • Degree of protection

All probes are tested to IP65.

### • EMC standard cable

All RED CROWN probes comply with EMC standards (EEC directive 89/336). This is invalidated if the probes are connected to electronic systems which do not comply with EMC standards.



## COMPLETE YOUR MEASURING APPLICATION WITH RED CROWN COMPANION PRODUCTS

### **AMA** (Advanced Measuring Armset)

Comprehensive line of wearless mechanical measuring devices developed to satisfy the requirements of the gauging market.

The main feature of the product is the universal applicability achieved by: 15 different designs, 8 mm and 3/8" clamping diameter, high precision and reliability, compact design (12 mm thickness), variety of mounting options, wide range of contact offsets.



**TB10**



**TS12**



**TP12E**



**TP60E**

#### APPLICATION EXAMPLES

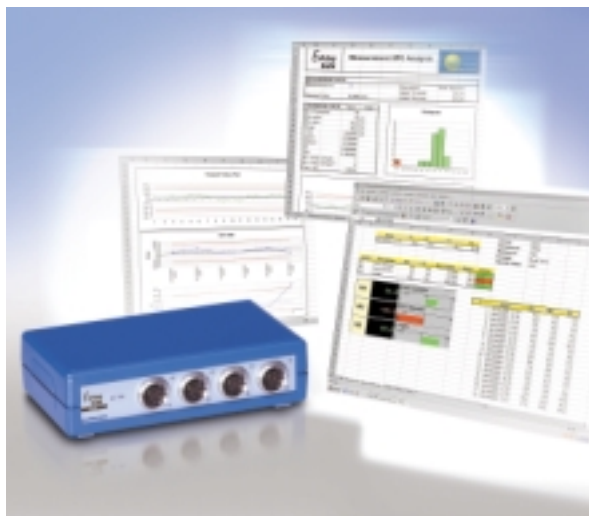
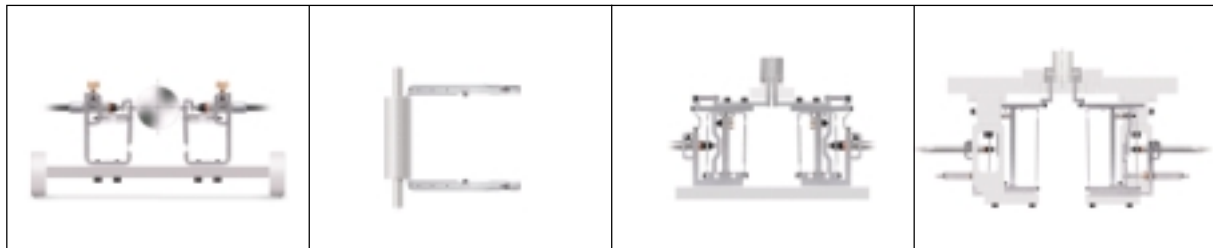

**Easy  
box**

Easy Box™ is an interface box that allows easy and economical connection of Red Crown™ pencil probes with LVDT (full-bridge) or HBT (half-bridge) transducer to any commercial Personal Computer via USB port (Universal Serial Bus). Simple Easy Acquisition™ measurement, data collection and SPC software package for Microsoft® Excel makes configuration and measurement value display a quick and easy task.

**For more information about AMA™ and Easy Box™ download the related catalogue from [www.testar.com](http://www.testar.com)**

**For a full list of address locations, please consult the Marposs official website [www.marposs.com](http://www.marposs.com) - [www.testar.com](http://www.testar.com)**

**D6L01002G0** - Edition 03/2006 - Specifications are subject to modifications  
© Copyright 2006 MARPOSS S.p.A. (Italy) - All rights reserved.

MARPOSS, ® logo and other names/signs, related to Marposs products, cited or showed in this document are registered marks or MARPOSS marks in the United States or in other countries. Rights of third parties on marks or registered marks, cited in the present document, are acknowledged to the relevant owners.

**Marposs has an integrated system to manage the Company quality, the environment and safety, attested by ISO 9001, ISO 14001 and OHSAS 18001 certifications. Marposs has further been qualified EAQF 94 and has obtained the Q1-Award**

