

BALL/PIN DOB/DOP GAGES

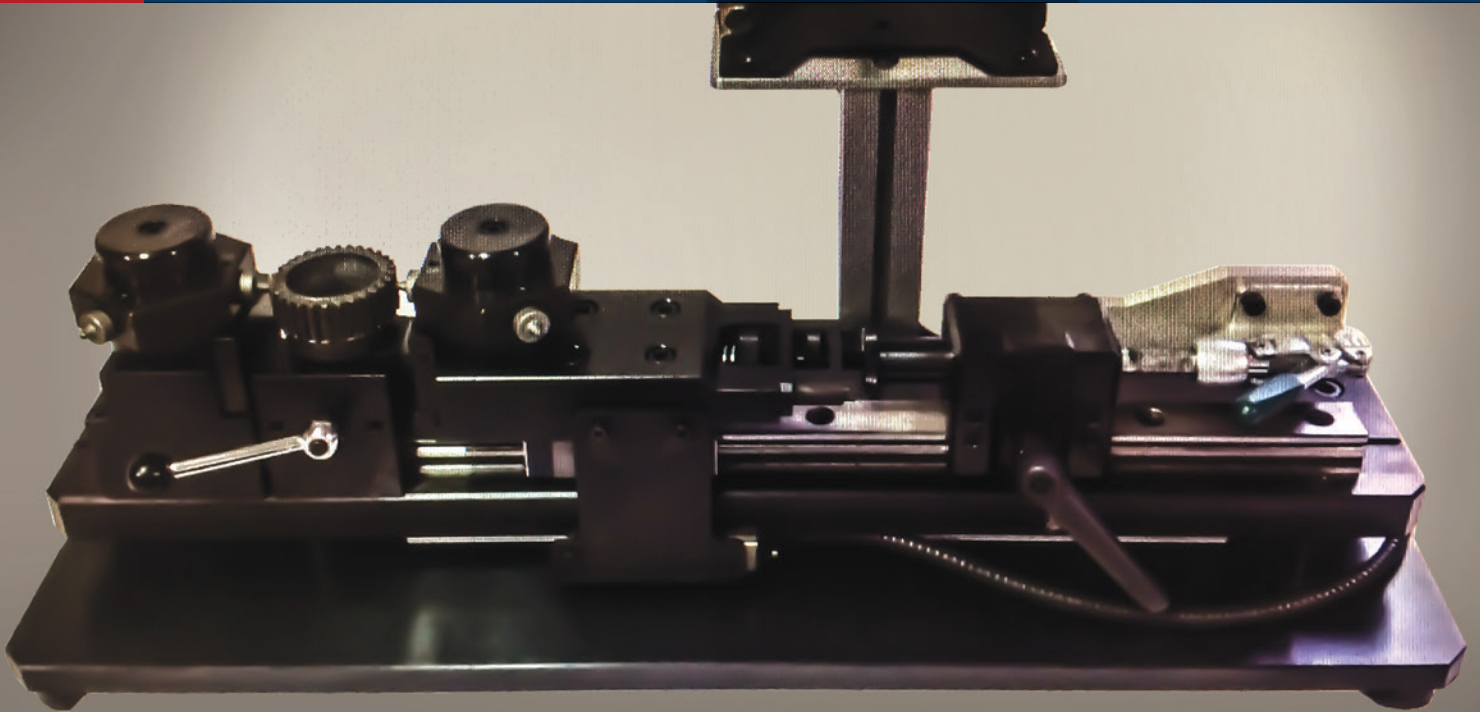

Veit Tool & Gage Dimension over ball/pin DOB/DOP gages are used typically to measure pitch diameters of gears and splines, but not limited too. Our gages are designed for accuracy, durability and ease of use, with consistent upgrades as technology advances. They are very versatile in their ability to accurately measure a variety of part features.



QUALITY & PRECISION

BALL/PIN DOB/DOP GAGES

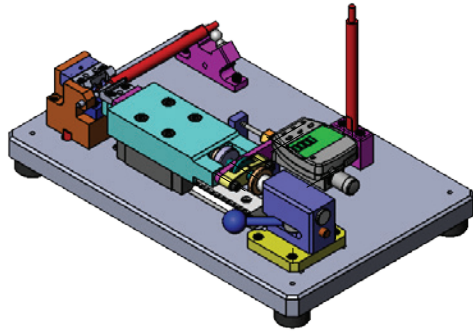
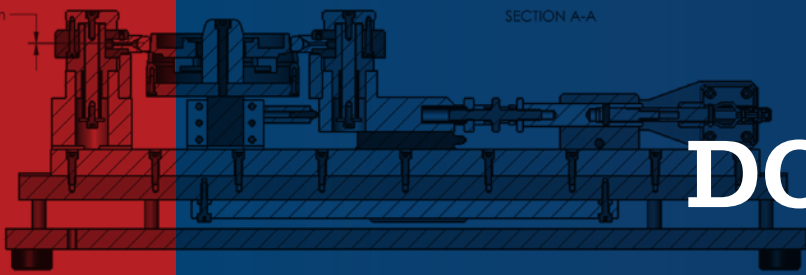

Our Veit Tool & Gage units have been utilized in the manufacturing industry for 30 years. From our simple economical 2-anvil single tool unit with indicator, to our “Dual” 3-station turret head design unit with optional part elevator platen, or custom design unit to fit your specific application. We design for accuracy.

CAPABILITIES

- Accuracy and repeatability to 2 micron
- Flexible capacity to handle a variety of part types and sizes on our “Standard” units

KEY FEATURES

- Shop floor durability
- Capable of both internal and external applications
- Adjustable mesh engagement pressure
- Choice of mechanical or electronic indicator, digital probe or glass scale
- MarCom wireless data transfer software/with Mahr Type 1086RI electronic indicator
- Solartron IS5500 digital probe readout/ with digital probe
- Marposs Nemo Unit with probe
- Or use data collection device of your choice

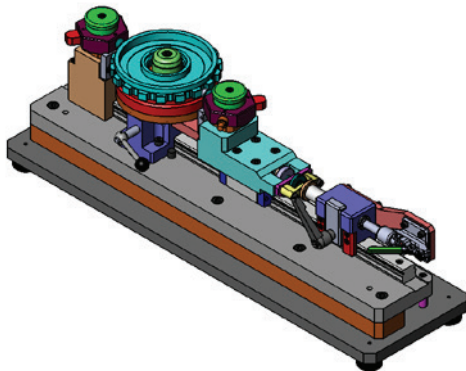
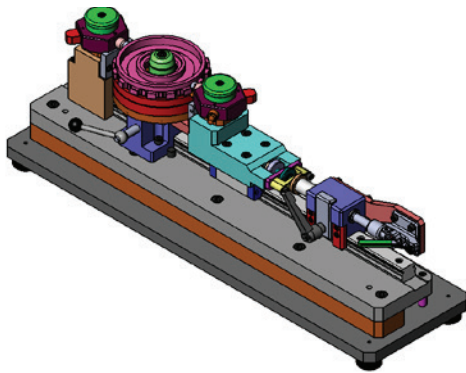

AHB
TOOLING & MACHINERY

**COMPLETE
METALWORKING
SOLUTIONS**

(800) 991-4225

www.ahbinc.com

ISO Certified

customerservice@ahbinc.com

Veit
TOOL & GAGE