

FREE CUTTER BODY

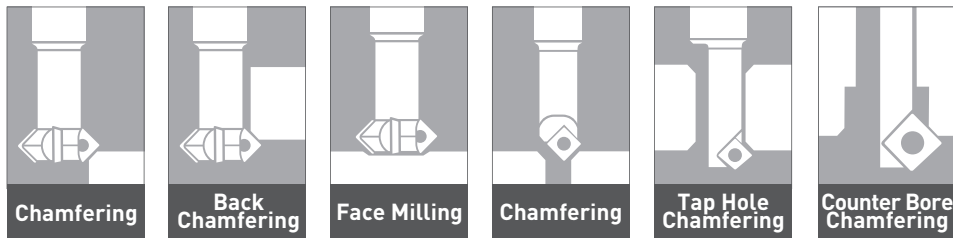

RECEIVE A FREE CUTTER BODY WITH THE PURCHASE OF 30 INSERTS



PROMO CODE: PROMO-CUT

INSERTS

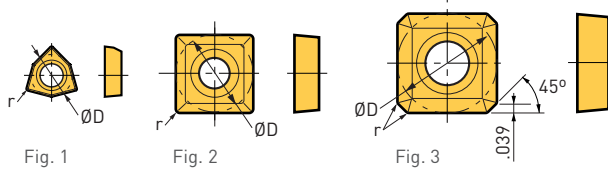
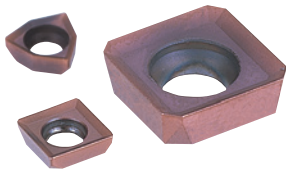

ACP200/ACP300	ACM250F	DS20	NF15KA
For all steel & stainless steel materials.	For stainless steel	For aluminum & /non-ferrous materials.	For cast iron
Multi-layer PVD coating on carbide base with nanoscale TiAlN & AlCrN. Excellent performance and wear resistance.	PVD-coated carbide with excellent smoothness and resistance to welding and chipping, due to the ultra-multilayered thin film structure made of AlTiN and TiAlCrN	DLC coating on carbide base with very smooth surface for a low coefficient of friction. Excellent performance against built-up edge.	Adopts K15-equivalent carbide material with hardness & toughness for cast iron.

Insert Model	Fig.	ØD	Nose Radius	Insert Grade					Insert Clamping Screw Set
				ACP200	ACP300	ACM250F	DS20	NF15KA	
CM0302	1	.130	.008	—	○	○	○	—	S1.63-T3
CM0402	1	.156	.008	—	○	○	○	—	S2SS-T6
CM0502	2	.197	.008	○	—	○	○	○	S2TS-T6
CM0502SE				○	○	—	—	—	
CM10C1	3	.394	.008	○	—	○	○	○	S4S-T15
CM10C1SE				○	—	—	—	—	

- Must purchase 30 of the same insert to receive the free cutter body
- Inserts are available in packages of 10 pcs.
- SE (sharp edge) type prevents burrs; recommended for stainless steel & mild steel

FREE CUTTER BODY TYPES



C-CUTTER MINI—MULTI-INSERT TYPE



4 inserts & small cutting diameter. High-performance chamfer cutter achieves ultra-high feed rate by reducing the cutting diameter to the lowest limit.

C-CUTTER MINI—SINGLE INSERT TYPE



Reduces the cutting diameter to the lowest limit, helping to achieve ultra-high spindle speeds and feeds. Delivers multi-functional cutting, including chamfering, back chamfering, and even light face milling.

C-CUTTER MINI—FRONT CHAMFER TYPE



Ultra-high feed chamfering mill with a compact design.

C-CUTTER MINI—BOLT AND TAPPED HOLE TYPE

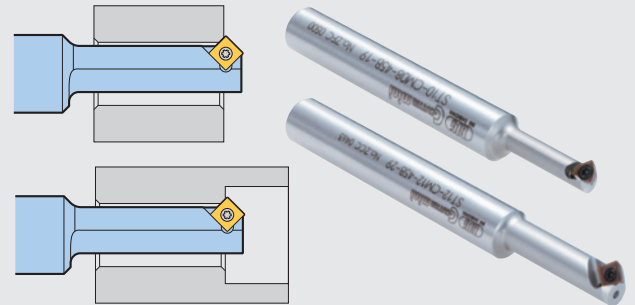

C-CUTTER MINI—SINGLE INSERT (Ø10-20mm)

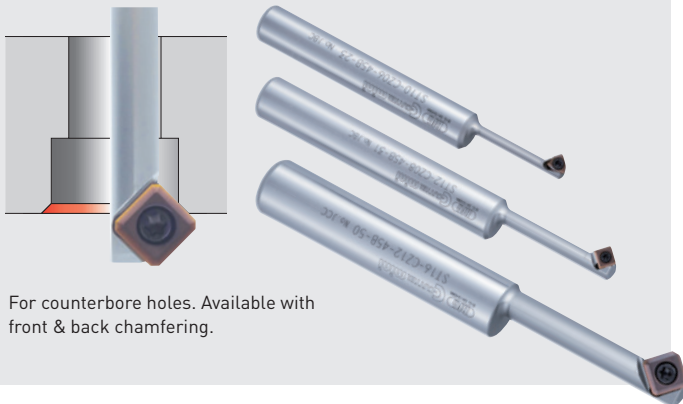

For counterbore holes. Available with front & back chamfering.

C-CUTTER MINI—CKB TYPE

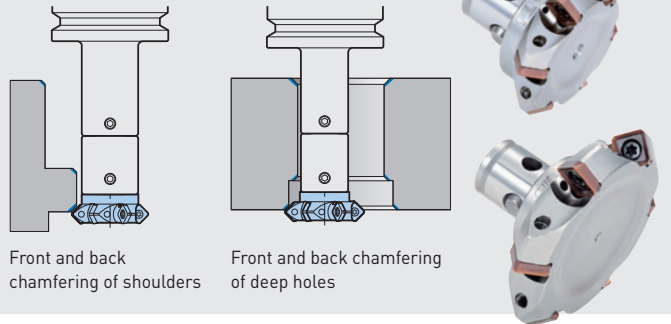

Front and back chamfering of shoulders

Front and back chamfering of deep holes

BF-CUTTER

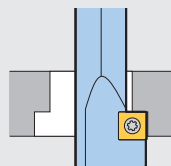

Exclusively designed for back spot facing of cap bolt holes.

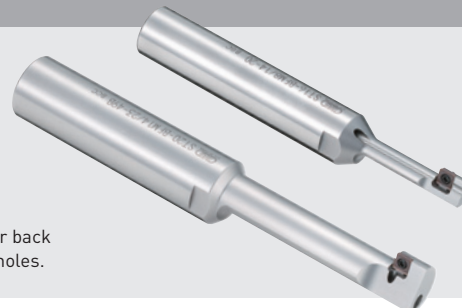

CATALOG



(800) 991-4225

www.ahbinc.com • customerservice@ahbinc.com

ISO Certified