

SUMMER OF SAVINGS!



COMPLETE METALWORKING SOLUTIONS
(800) 991-4225 www.ahbinc.com
ISO Certified customerservice@ahbinc.com



High Feed Milling ISSN11

A wide range of tools for economical high feed milling in die and mold and general machining industries. Strong inserts with eight cutting edges for high performance machining of various materials and applications.

Purchase
30 inserts
and a body
up to 4"

Save up to
70%
on select indexable milling
packages



ISSN11

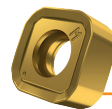

SNGX-M

- 8-edged HFC insert
- Steels and cast steels
- Secondary: cast iron

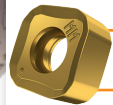

SNGX-MM

- 8-edged HFC insert
- Stainless steels, soft steels and cast steels, and superalloys

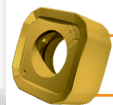

SNGX-HM

- 8-edged HFC insert
- Hard steels, cast irons
- Medium and rough cuts

NEW

▶ **DOUBLE-SIDED SQUARE INSERTS**
with eight cutting edges

▶ **HIGH PERFORMANCE IN**
copy milling, helical interpolation,
ramping and face milling

▶ **ALL CUTTERS FEATURE**
special through coolant design

▶ **INCREASED PRODUCTIVITY**
High feed milling with up to 50%
higher metal removal rates due to
greater depth of cut capability

▶ **AXIAL DEPTH OF CUT**
up to .067"



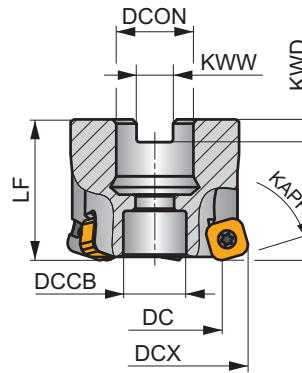
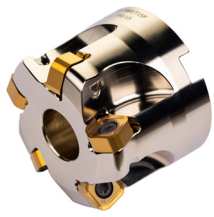

KAPR 18°

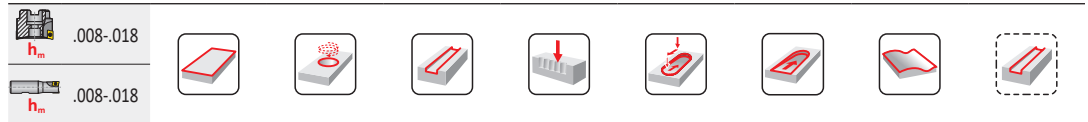
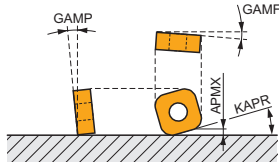
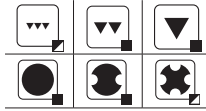

Product	MID	DC	DCX	LF	DCON MS	DCCB	KWW	KWD	GAMP	GAMF		
		[inch]	[inch]	[inch]	[inch]	[inch]	[inch]	[inch]	[°]	[°]		
Medium pitch												
150A04R-ISMOSN11-C	7800651	0.957	1.500	1.575	0.500	0.409	0.258	0.165	-10	-10.5	4	v
200A05R-ISMOSN11-C	7800652	1.453	2.000	1.575	0.750	0.630	0.321	0.193	-10	-10	5	v
250A06R-ISMOSN11-C	7800654	1.953	2.500	1.575	0.750	0.630	0.321	0.193	-10	-10	6	v
300A07R-ISMOSN11-C	7800656	2.453	3.000	1.969	1.000	0.827	0.382	0.224	-10	-10	7	v
400A08R-ISMOSN11-C	7800658	3.453	4.000	1.969	1.500	1.417	0.630	0.382	-10	-10	8	v
Fine pitch												
200A06R-ISMOSN11-C	7800653	1.453	2.000	1.575	0.750	0.630	0.321	0.193	-10	-10	6	v
250A08R-ISMOSN11-C	7800655	1.953	2.500	1.575	0.750	0.630	0.321	0.193	-10	-10	8	v
300A09R-ISMOSN11-C	7800657	2.453	3.000	1.969	1.000	0.827	0.382	0.224	-10	-10	9	v

Inserts

SNGX-M

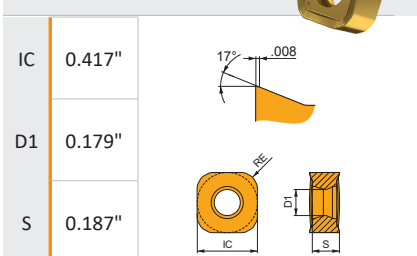

M	MID	P	K
8215	7799778	10-20	10-25
M8310	7799777	01-10	01-10
M8330	7799779	20-40	20-40
M8340	7799790	25-50	20-40
M9325	7799791	10-30	10-30
M9340	7799792	35-50	

SNGX-MM

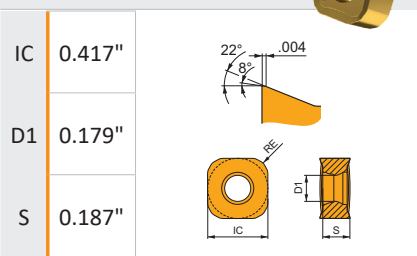

M	MID	P	M	S
M6330	7799794	20-35	20-35	20-30
M8340	7799795	25-50	20-40	20-30
M8345	7799796	30-50	30-40	20-30
M9340	7799797	35-50	30-40	15-20

SNGX-HM

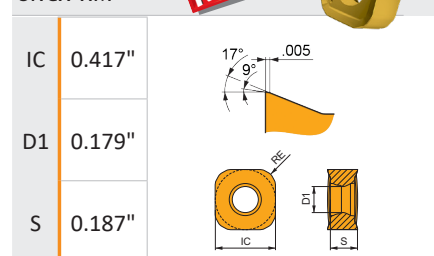

M	MID	P	K	H
8215	8174569	10-20	10-25	10-15
M8310	8174564	01-10	01-10	05-15
M8330	8174565	20-40	20-40	15-25
M9325	8174620	10-30	10-30	15-20

Primary use
 Stable working conditions - Primary use
 Very unstable working conditions - Possible use
 Possible use
 Unstable working conditions - Primary use

Take advantage of this offer use **Promo Code SS** when ordering.
 Offer is not valid on purchases made by Eshop or EDI
 Promotion Runs From July 1 to August 31, 2023

Contact your local sales person for application assistance.