

Member IMC Group

IT.TE.DI.

2026 PROMO

VALID APRIL 1- OCTOBER 31, 2026

PC IT261

PROMO #1



Receive 25% off the purchase of a new tool*, plus, get that tool re-tipped at \$50 per pocket.

PROMO #2

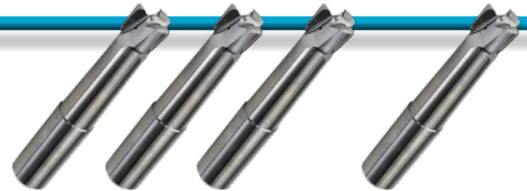

Purchase 3 tools* at regular price, receive the fourth tool for FREE.**

***Purchase 3 get 1 free, must be of the same item.*

PC IT262

*See the following pages of this flyer for a list of qualifying tools

TEDI BRZ REAM

BRZ LINE



MICRO LINE

(800) 991-4225

www.ahbinc.com • customerservice@ahbinc.com

ISO Certified

End Mills	
	Description
	EBSED16Z03CM16L30R02
	EBSED20Z03CM20L30R02
	EBSED25Z03CM25L30R02
	EBSEI10Z03CM25L30R02
	EBSEI62Z03CM16L30R02
	EBSEI75Z03CM20L30R02

End Mills	
	Description
	EBSPD10Z03CM10L10R02
	EBSPD12Z03CM12L10R02
	EBSPD14Z03CM14L10R02
	EBSPD16Z03CM16L10R02
	EBSPD20Z03CM20L10R02
	EBSPI37Z03CM10L10R02
	EBSPI50Z03CM12L10R02
	EBSPI62Z03CM16L10R02
	EBSPI75Z03CM20L10R02

End Mills	
	Description
	EBSTD04Z01CM05L10C01
	EBSTD05Z01CM05L10C01
	EBSTD06Z02CM06L10C01
	EBSTD06Z02CM06L20C01
	EBSTD08Z02CM08L10C01
	EBSTD08Z02CM08L20C01
	EBSTD10Z02CM10L10C02
	EBSTD10Z02CM10L20C02
	EBSTD12Z02CM12L10C02
	EBSTD12Z02CM12L20C02
	EBSTI15Z01CM05L10C01
	EBSTI18Z01CM05L10C01
	EBSTI25Z02CM06L10C01
	EBSTI25Z02CM06L20C01
	EBSTI31Z02CM08L10C01
	EBSTI31Z02CM08L20C01
	EBSTI37Z02CM10L10C01
	EBSTI37Z02CM10L20C02
	EBSTI50Z02CM12L10C01
	EBSTI50Z02CM12L20C02

Ball Nose End Mills	
	Description
	EBSSD03Z02CM06L03R15-PB
	EBSSD04Z02CM06L03R20-PB
	EBSSD05Z02CM06L03R25-PB
	EBSSD06Z02CM06L06R30-PB
	EBSSD08Z02CM08L10R40-PB
	EBSSD10Z02CM10L10R50-PB
	EBSSD12Z02CM12L10R60-PB
	EBSSD16Z02CM16L10R80-PB
	EBSSI13Z02CM06L03R15-PB
	EBSSI15Z02CM06L03R20-PB
	EBSSI18Z02CM06L03R25-PB
	EBSSI25Z02CM06L06R30-PB
	EBSSI31Z02CM08L10R40-PB
	EBSSI37Z02CM10L10R50-PB
	EBSSI05Z02CM12L10R60-PB
	EBSSI62Z02CM16L10R80-PB

End Mills	
	Description
	EBSRD16Z03CM16L10R20-PB
	EBSRD20Z03CM20L12R30-PB
	EBSRD25Z03CM25L15R30-PB
	EBSRD32Z03CM32L18R40-PB
	EBSRI62Z03CM16L10R20-PB
	EBSRI75Z03CM20L12R30-PB
	EBSRI10Z03CM25L15R30-PB
	EBSRI12Z03CM32L18R40-PB

Reamers	
	Description
	ITSRG-B-D06.000-C02
	ITSRG-B-D08.000-C02
	ITSRG-B-D10.000-C04
	ITSRG-B-D12.000-C04
	ITSRG-T-D06.000-K05
	ITSRG-T-D08.000-K05
	ITSRG-T-D10.000-K05
	ITSRG-T-D12.000-K10

End Mills	
	Description
	EBSED16Z03CM16L30R02
	EBSED20Z03CM20L30R02
	EBSED25Z03CM25L30R02
	EBSEI10Z03CM25L30R02
	EBSEI62Z03CM16L30R02
	EBSEI75Z03CM20L30R02

End Mills	
	Description
	EBSPD10Z03CM10L10R02
	EBSPD12Z03CM12L10R02
	EBSPD14Z03CM14L10R02
	EBSPD16Z03CM16L10R02
	EBSPD20Z03CM20L10R02
	EBSPI37Z03CM10L10R02
	EBSPI50Z03CM12L10R02
	EBSPI62Z03CM16L10R02
	EBSPI75Z03CM20L10R02

End Mills	
	Description
	EBSTD04Z01CM05L10C01
	EBSTD05Z01CM05L10C01
	EBSTD06Z02CM06L10C01
	EBSTD06Z02CM06L20C01
	EBSTD08Z02CM08L10C01
	EBSTD08Z02CM08L20C01
	EBSTD10Z02CM10L10C02
	EBSTD10Z02CM10L20C02
	EBSTD12Z02CM12L10C02
	EBSTD12Z02CM12L20C02
	EBSTI15Z01CM05L10C01
	EBSTI18Z01CM05L10C01
	EBSTI25Z02CM06L10C01
	EBSTI25Z02CM06L20C01
	EBSTI31Z02CM08L10C01
	EBSTI31Z02CM08L20C01
	EBSTI37Z02CM10L10C01
	EBSTI37Z02CM10L20C02
	EBSTI50Z02CM12L10C01
	EBSTI50Z02CM12L20C02

Ball Nose End Mills	
	Description
	EBSSD03Z02CM06L03R15-PB
	EBSSD04Z02CM06L03R20-PB
	EBSSD05Z02CM06L03R25-PB
	EBSSD06Z02CM06L06R30-PB
	EBSSD08Z02CM08L10R40-PB
	EBSSD10Z02CM10L10R50-PB
	EBSSD12Z02CM12L10R60-PB
	EBSSD16Z02CM16L10R80-PB
	EBSSI13Z02CM06L03R15-PB
	EBSSI15Z02CM06L03R20-PB
	EBSSI18Z02CM06L03R25-PB
	EBSSI25Z02CM06L06R30-PB
	EBSSI31Z02CM08L10R40-PB
	EBSSI37Z02CM10L10R50-PB
	EBSSI05Z02CM12L10R60-PB
	EBSSI62Z02CM16L10R80-PB

End Mills	
	Description
	EBSRD16Z03CM16L10R20-PB
	EBSRD20Z03CM20L12R30-PB
	EBSRD25Z03CM25L15R30-PB
	EBSRD32Z03CM32L18R40-PB
	EBSRI62Z03CM16L10R20-PB
	EBSRI75Z03CM20L12R30-PB
	EBSRI10Z03CM25L15R30-PB
EBSRI12Z03CM32L18R40-PB	

Reamers	
	Description
	ITSRG-B-D06.000-C02
	ITSRG-B-D08.000-C02
	ITSRG-B-D10.000-C04
	ITSRG-B-D12.000-C04
	ITSRG-T-D06.000-K05
	ITSRG-T-D08.000-K05
	ITSRG-T-D10.000-K05
	ITSRG-T-D12.000-K10

Micro Mills	
	Description
	SMHED03Z04CM06L02R01
	SMHED04Z04CM06L04R01
	SMHED05Z04CM06L04R01
	SMHED06Z04CM06L04R01
	SMHED07Z04CM08L04R02
	SMHED08Z04CM08L04R02

Micro Mills	
	Description
	SMSPD03Z04CM06L02R01
	SMSPD04Z06CM06L04R20
	SMSPD05Z04CM06L04R01
	SMSPD06Z04CM06L04R01
	SMSPD07Z04CM08L04R02
	SMSPD08Z04CM08L04R02

Micro Mills	
	Description
	SMTOD03Z04CM06L02R01
	SMTOD04Z04CM06L04R01
	SMTOD05Z04CM06L04R01
	SMTOD06Z03CM06L02R15
	SMTOD07Z04CM08L04R02
	SMTOD08Z04CM08L04R02



COMPLETE METALWORKING SOLUTIONS
 (800) 991-4225 www.ahbinc.com
 ISO Certified customerservice@ahbinc.com

REQUEST A QUOTE

Send us any competitor's round, cylindrical shank, brazed PCD milling cutter, and we'll re-tip it for \$50 per PCD pocket. Ask your local AHB/IT.TE.DI. sales representative to quote this special deal.

