

ANGLE HEAD

UNIVERSAL TYPE AGU30

OPERATION MANUAL

Please be sure to read this manual before using the product.

Consult the separate operation manual for Angle Head also regarding the general handling of the Angle Heads.

Thank you for purchasing the **(BIG)** ANGLE HEAD.
Please read these instructions before use and keep them where
the operator may refer to them whenever necessary.

Regarding the safety

The following indicator is used in the operation manual to signify points relating to safe operation. Please ensure these points are fully understood and followed correctly.

 Caution	Should this equipment be incorrectly operated injury is possible to the operator, or other personnel in the area. Equipment may also be damaged.
---	--

ANGLE HEAD

The **(BIG)** Angle Head contributes to efficient machining by reducing setup times and production processes, allowing automatic tool change and full adjustment of the cutter head direction.

● INDEX ●

■ SPECIFICATIONS	P 2
■ OPERATION SEQUENCE	P 3
■ OPERATION PROCEDURES	
1. How to adjust the cutter angle	P 4
2. How to check the cutter direction	P 8
3. How to adjust the cutter direction	P 9
4. Installation of the cutting tool	P11
■ OTHER	
1. Coolant feed to the cutting edge	P12

SPECIFICATIONS

#40 Taper Shank BBT, BIV, BDV, BCV40 SHANK

Maximum spindle speed (min ⁻¹)	6,000
Speed ratio (Body : Spindle)	1 : 1
Rotation direction	Forward

Notes)

- The fixed length A varies according to the machining center model.
- If the unit is used for more than 30 minutes at a speed near the maximum spindle speed, it should be cooled by supplying air or coolant via the Stop Block.

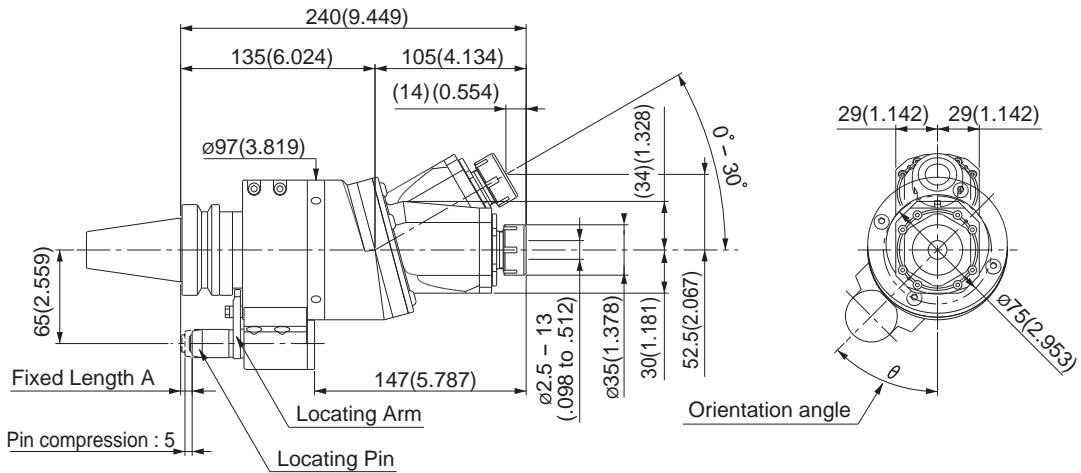

#50 Taper Shank BBT, BIV, BDV, BCV50 SHANK

Maximum spindle speed (min ⁻¹)	4,000
Speed ratio (Body : Spindle)	1 : 1
Rotation direction	Forward

Notes)

- The fixed length A varies according to the machining center model.
- If the unit is used for more than 30 minutes at a speed near the maximum spindle speed, it should be cooled by supplying air or coolant via the Stop Block.

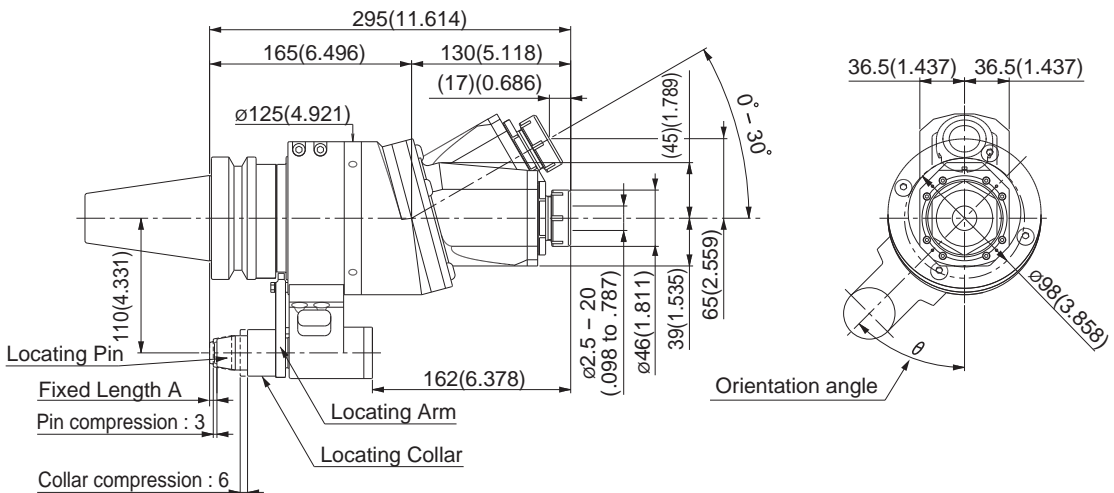

OPERATION SEQUENCE

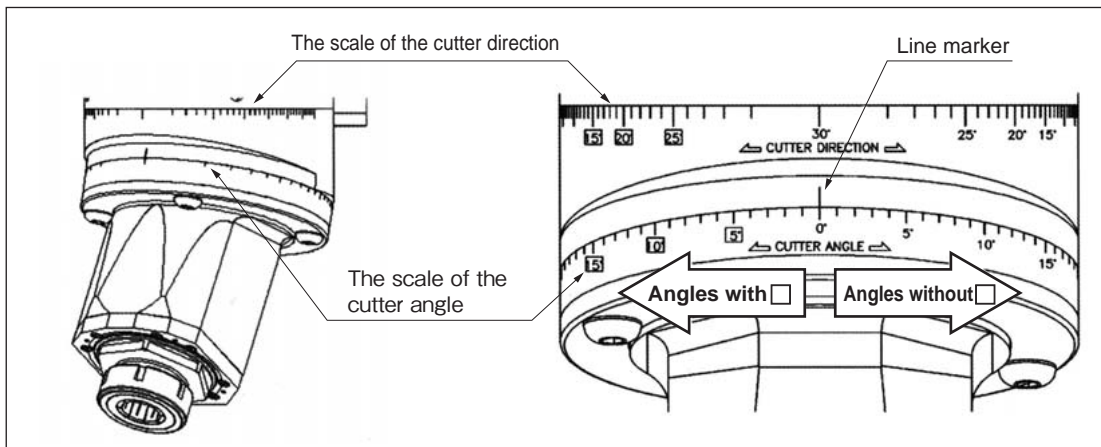

1 How to adjust the cutter angle

For details, consult P4 – P7

Adjust the line marker to the cutter angle that you wish to set. The angle without □ (example: 15°) and the angle with □ (example: 15°) indicate the same cutter angle.

2 How to check the cutter direction

For details, consult P8

Adjusting the cutter angle changes the cutter direction also. Read the same value of the scale of the cutter direction with the value of the scale of the cutter angle you set, and check that the values of the scales match each other. In the case the cutter angle is adjusted without □, check that the scale of the cutter direction is also without □. If the cutter angle is adjusted with □, check that the scale of the cutter direction is also with □.

3 How to adjust the cutter direction

For details, consult P9 – P10

Use the enclosed Setting Disk to precisely adjust the cutter direction.

4 Installation of the cutting tool

For details, consult P11

OPERATION PROCEDURES

1 How to adjust the cutter angle



CAUTION

Do not adjust the cutter angle while a cutting tool is mounted, as it is extremely dangerous to do so.

- 1 Use the short head of the included hex key (consult the CAUTION below) and loosen the (4) Clamping Bolts a little. Please be aware that if the Clamping Bolts are released by too much, this creates excessive **clearance** between the Head Case and the Connection Case making not possible to adjust the angle correctly. (Fig.1)

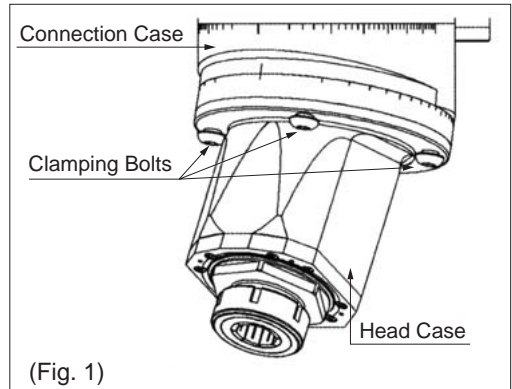

(Fig. 1)



CAUTION

Due to the interference with the Head Case, use the short head of the included hex key to tighten or release the Clamping Bolts.

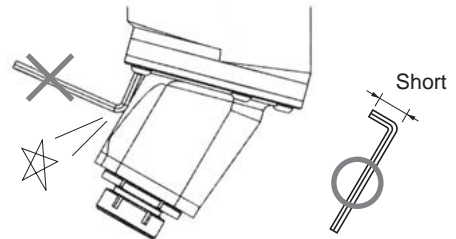

- 2 Hold the Head Case by hand and rotate to the selected angle. To set an angle, use the line marker on the Connection Case and the scale of the cutter angle on the Head Case. (Fig. 2) (If it is not possible to swivel the Head Case to the selected angle, it is necessary to remove the Clamping Bolts. In this case, consult the page 6 [If it is necessary to remove the Clamping Bolts]).

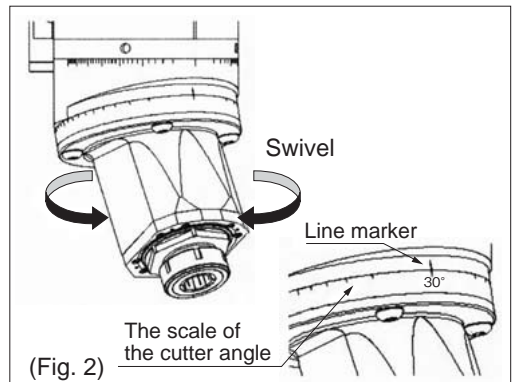

(Fig. 2)

In the cutter angle's scale, there are (2) types of scale: with/without □ (examples: 15° and 15°). Both scales indicate the same cutter angle. (Fig. 3)

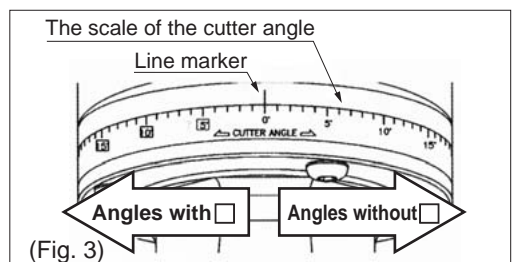

(Fig. 3)



CAUTION

The Head Case may become stuck when swiveling. In this case, rotate the machine spindle manually and slowly to rotate the Angle Head's spindle by a little. This will release the Head Case permitting it to rotate smoothly. Be aware that rotating the Angle Head forcefully may damage the driving parts.

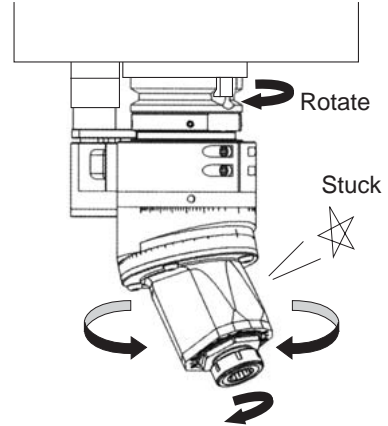

3

Use the short head of the included hex key to tighten the (4) Clamping Bolts uniformly.



CAUTION

NEVER exceed the tightening torque by using an extension.

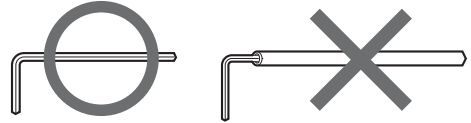

OPERATION PROCEDURES

[If it is necessary to remove the Clamping Bolts]

Structure's view

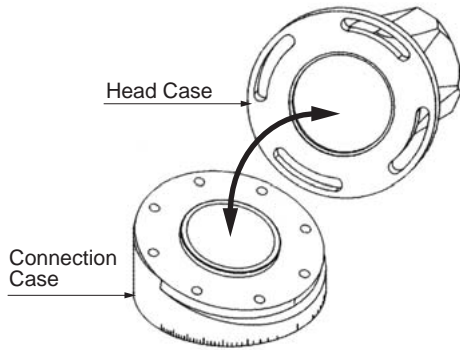

The structure of the turning Head Case is indicated in the picture to the right. For every 45° swivel, it is necessary to remove the Clamping Bolts and to substitute the position of the screw holes.

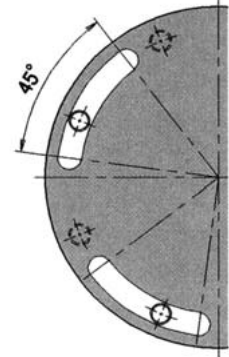

- 1 Use the short head of the included hex key to remove the (4) Clamping Bolts. Due to the interference with the Head Case there is (1) Clamping Bolt which cannot be removed. Remove this Clamping Bolt after having removed the interference by swiveling the Head Case. (Fig. 4)

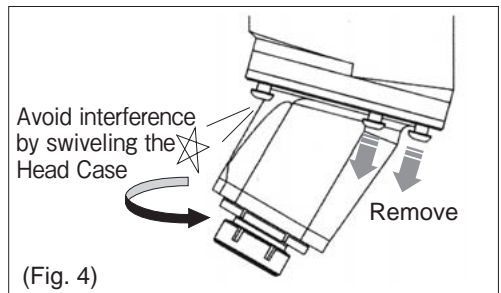

CAUTION

- Please be aware that, removing the Clamping Bolt forcefully while the interference exists, may damage the Head Case or the Clamping Bolt itself.
- Please be aware of losing or dropping the Setting Plate when the Clamping Bolts are removed and the Setting Plate becomes free from the Head Case.
- Even if the Clamping Bolts are removed, the Head Case will not come off from the Connection Case, but swarf or coolant may invade the internal parts via the gap between the cases. This can result in damage. When removing the Clamping Bolts, hold the Head Case in position so as not create clearance.

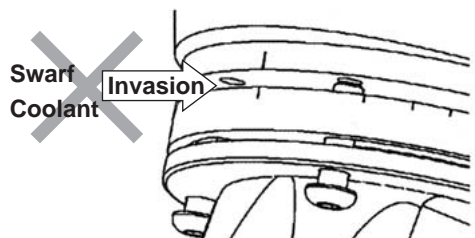
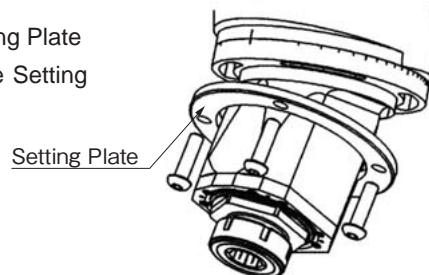

2 Hold the Head Case by hand and swivel it to the selected angle. To set an angle, use the line marker on the Connection Case and the cutter angle's scale on the Head Case. (Page 4 Fig. 2)

3 Rotate the Setting Plate in order to match the screw holes of the Connection Case and tighten the (4) Clamping Bolts temporarily. Due to the interference with the Head Case there is (1) Clamping Bolt which cannot be inserted. Insert this Clamping Bolt having removed the interference by rotating the Head Case. (Fig. 5)

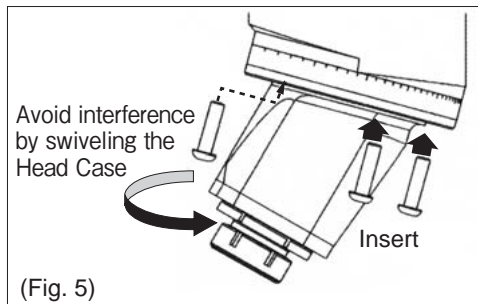

4 Use the short head of the included hex key to tighten the (4) Clamping Bolts uniformly.

[If it is necessary to set a very precise angle]

(Example)

Install the included Setting Disk to the Angle Head. (Consult the page 11 "Installation of the cutting tool".) By touching the reference face of the Setting Disk with a test indicator and using the machine feed (example: XZ axes) as shown in the figure, it is possible, by reading the test indicator's values, to check the deviation of the cutter angle. (Fig. 6)

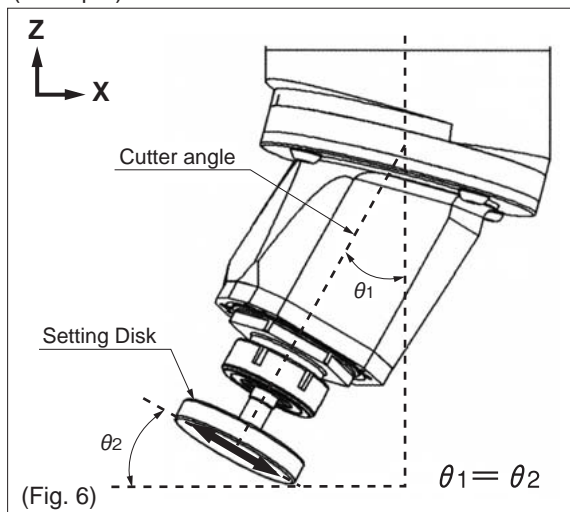

CAUTION

Changing the cutter angle will also change the cutter direction.
After adjusting the cutter angle, always check the cutter direction and adjust it if necessary.

OPERATION PROCEDURES

2 How to check the cutter direction

Adjusting the cutter angle will also change the cutter direction. (Fig. 7)

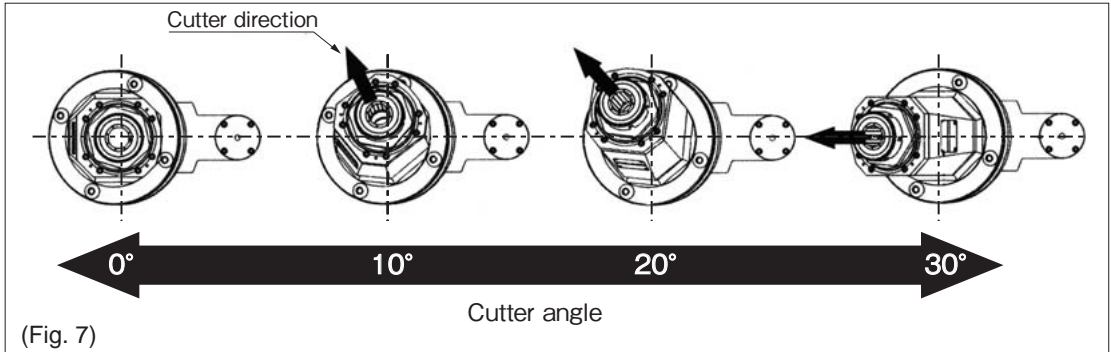

《 To check the cutter direction, follow the procedures below. 》

1 Read the same value of the scale of the cutter direction with the value of the scale of the cutter angle you set, and check that the values of the scales match each other. (Fig. 8 Example of the cutter angle set to 15°)

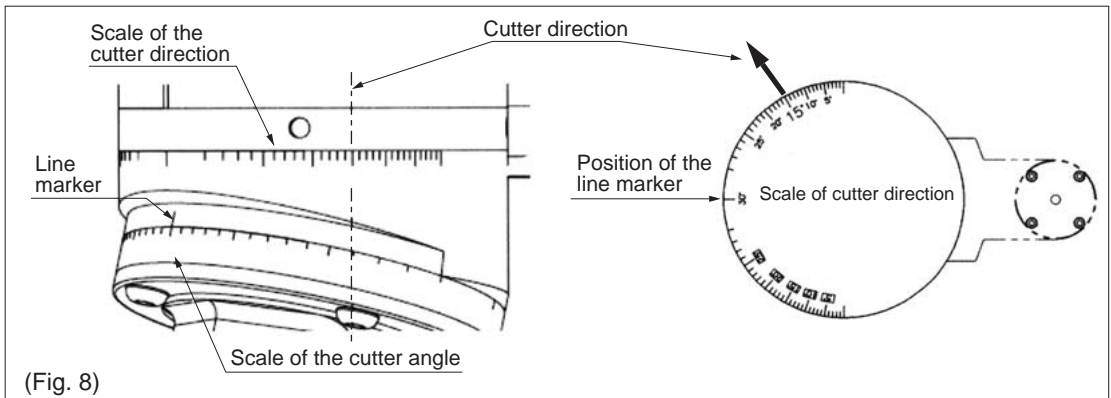

If the cutter angle is adjusted without , check that the scale of the cutter direction is also without . If the cutter angle is adjusted with , check that the scale of the cutter direction is also with .

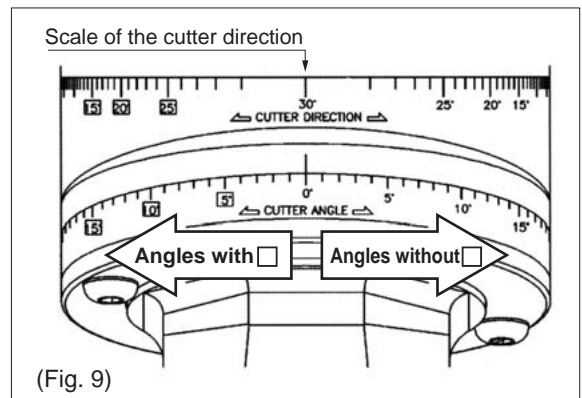

2 Using the position of the scale as the reference, adjust the cutter direction.

3 How to adjust the cutter direction

Since the Body Case attached with the Locating Pin holds the Adapter Case connected with the Connection Case, it is possible to set the cutter direction to any angle and to secure it easily with (2) Side Clamping Screws. (Fig. 10)

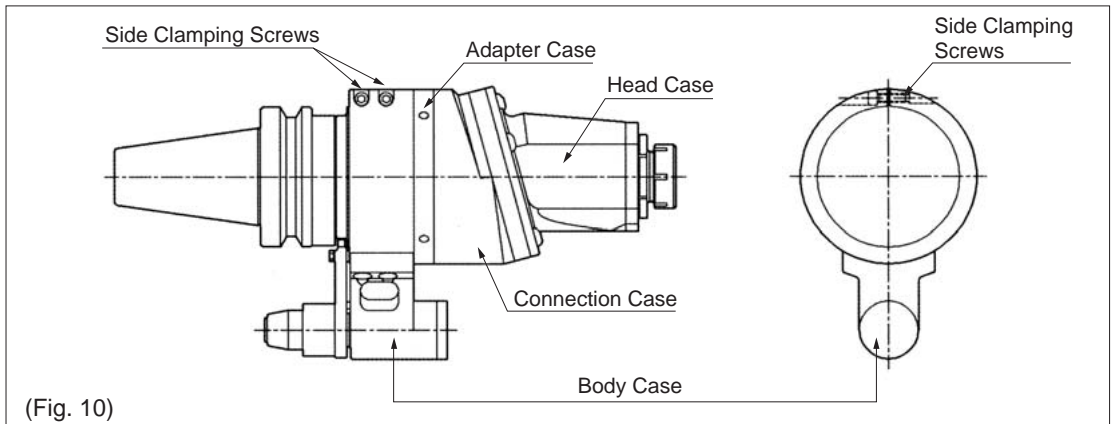

《 To adjust the cutter direction, follow the procedures below. 》

- 1 Install the Setting Disk enclosed in the Angle Head (Consult the page 11 “Installation of the cutting tool”) and loosen the (2) Side Clamping Screws a little while the Angle Head is mounted in the machine spindle. Please be aware that if the Side Clamping Screws are loosened too much, this allows clearance between the Body Case and the Adapter Case. (Fig. 11)

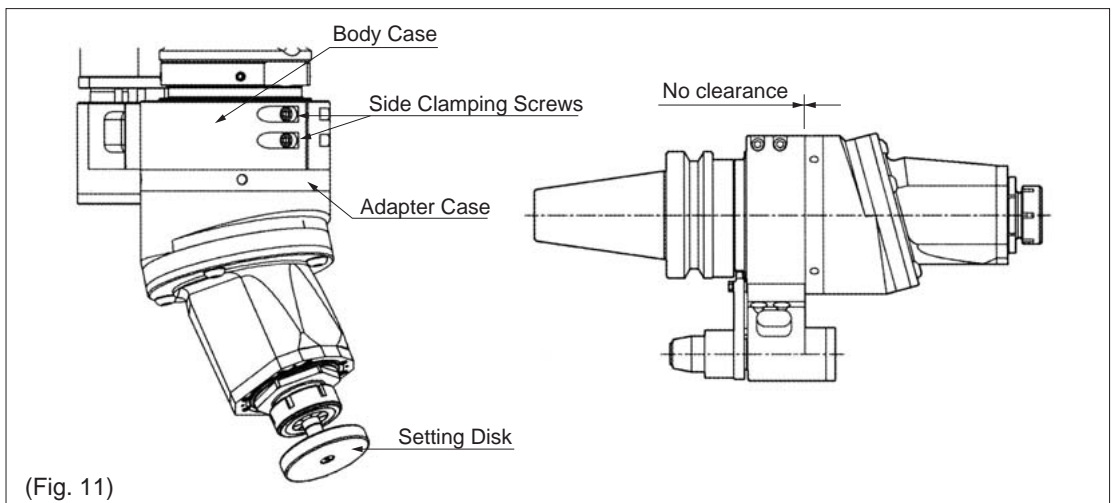

OPERATION PROCEDURES

- 2 Insert the Adjusting Rods in the side holes of the Adapter Case, rotate the Adapter Case and adjust the cutter direction. (Fig. 12)

It makes the adjustment easier to refer to the value of the scale of the cutter direction that was checked in the process [How to check the cutter direction] on page 8.

(Fig. 13: Example of the cutter angle set to 15°)

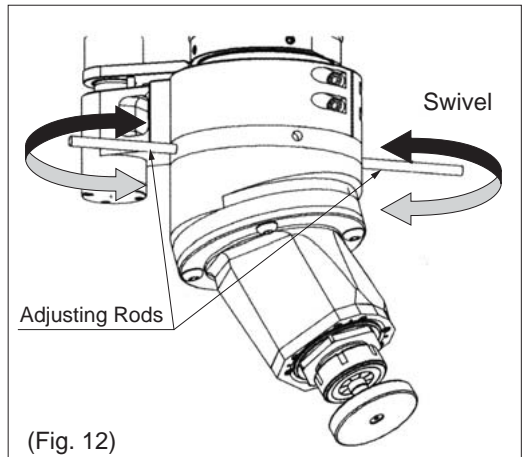

(Fig. 12)

[Example of the cutter angle set to 15°]

Following the example of "How to check the cutter direction" on page 8, the cutter is pointing toward the 15° position of the scale of the cutter direction. Use this value as a reference point and turn the Adapter Case to the selected direction. (Example here: parallel to the X axis)

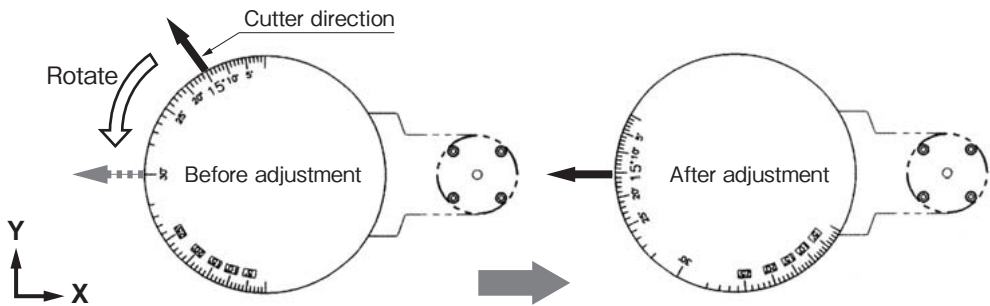

(Fig. 13)

- 3 By touching on to the reference face of the Setting Disk with a test indicator and moving in both right and left directions, it is possible to check the parallelism of the cutter direction with the target direction. Inserting the (2) Adjusting Rods in the Adapter Case at opposite positions will ease the fine adjustment. (Fig. 14)

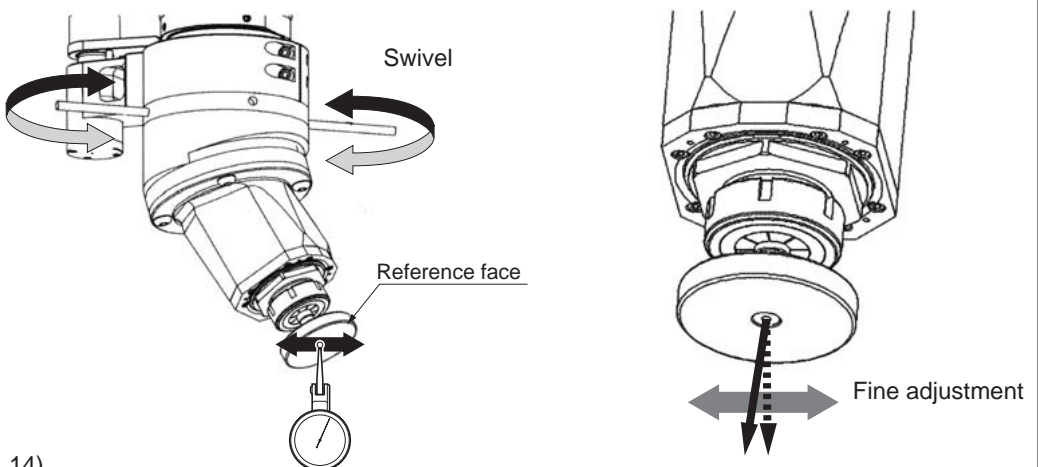

(Fig. 14)

4 Tighten the (2) Side Clamping Screws uniformly with the hex key.



CAUTION

- NEVER exceed the tightening torque by using an extension which may distort the Adapter Case.
- Changing the cutter angle will also change the cutter direction. Please pay enough attention when performing the adjustment process.

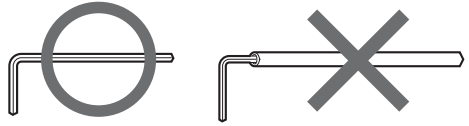

4 Installation of the cutting tool

Clean the inner diameter of the chuck and the cutting tool shank in order to completely remove traces of oil and particles. Insert the cutting tool and attach the accessory wrenches to the Spindle and the Nut and tighten.



CAUTION

- NEVER exceed the tightening torque by using an extension.
- Be sure to hold both the Spindle and Nut with the wrenches. Neglecting to do so will result in internal damage. NEVER clamp the flute portion of the cutting tool.
- ※NB Never fail to hold the Spindle.

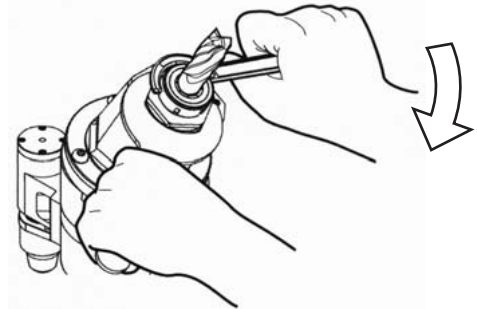

OTHER

1 Coolant feed to the cutting edge

Coolant feed to the cutting edge is achieved via a Stop Block which is connected to a coolant supply pipe. Coolant flow through the Body Case contributes to the cooling of the unit.

[※ The maximum coolant pressure is 1MPa (142PSI).]

If the Angle Head is stored for an extended period after using a water-soluble coolant, it may be subject to rust. Blow air through the Locating Pin to remove the remaining coolant and pour anticorrosion oil from the Locating Pin prior to storage. Before using the unit again, depress the Locating Pin by hand to check if it moves smoothly.



CAUTION

The Angle Head adopts non-contact seals. However, assure to adjust the nozzles of the machine so that the coolant directs not onto the unit but at the cutting tool. Neglecting to do so may cause penetration of coolant and internal damage.

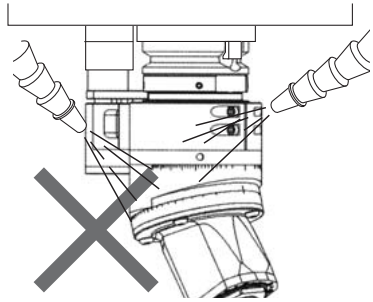

CAUTION

If the unit is used for more than 30 minutes at a speed near the maximum spindle speed, please cool by supplying air or coolant via the Stop Block.



BIG DAISHOWA SEIKI CO LTD

■ **EXPORT DEPARTMENT**

TEL : (+81)-72-982-8277 E-mail : export@big-net.ne.jp

■ **INTERNATIONAL TECHNICAL COMMUNICATION CENTER**

TEL : (+81)-72-982-2730 E-mail : medep@big-net.ne.jp