

Vol. 2

# ACCESSORIES

PERFORMANCE ENHANCING  
SOLUTIONS

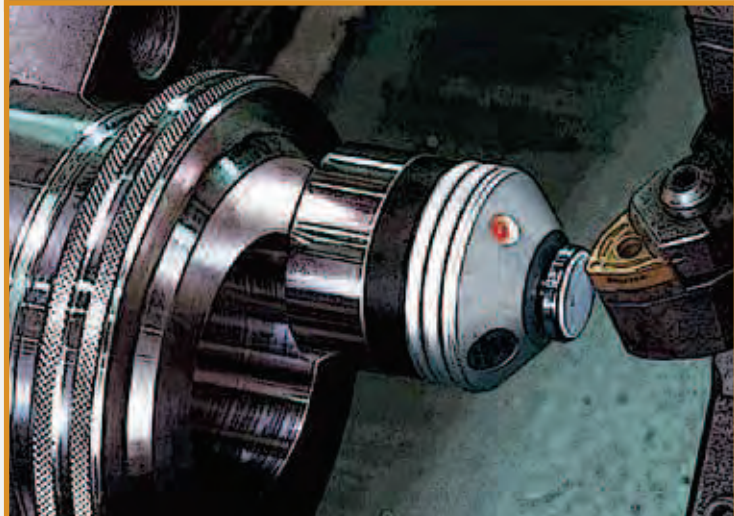
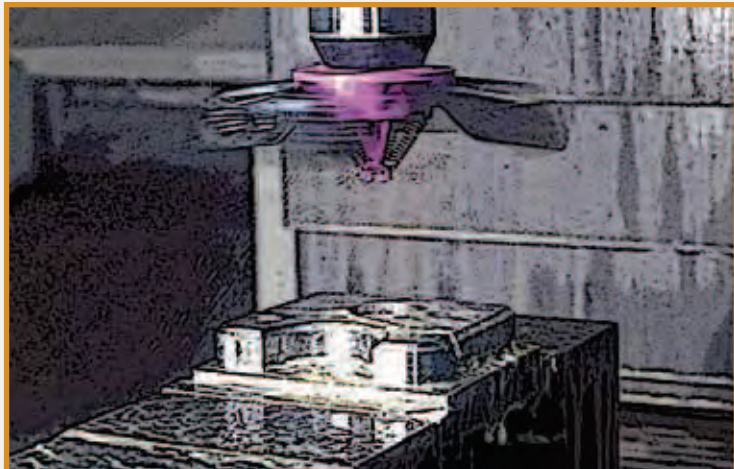

A PRODUCT OF:

**BIG KAISER**<sup>®</sup>  
**PRECISION TOOLING INC.**  
Higher Performance. Guaranteed.

# ACCESSORIZE TO MAXIMIZE PERFORMANCE & EFFICIENCY

When purchasing new equipment, it is typical to spend a great deal of time researching which machine offers the specifications and features to meet your needs. But once you've purchased a machine and installation is complete, what should you be doing to maximize its performance?

BIG Kaiser Precision Tooling offers a unique lineup of economical accessories designed to optimize your productivity and help you operate at peak efficiency.

From dial indicator stands for fast, flexible measurement and inspection, to compact sensors for touching off tools — we offer many ingenious setup accessories that make your work flow faster and more efficient.

To keep your machines running smooth and operating at top performance, don't forget our unique line of clean-up accessories including chip fans and spindle cleaners.

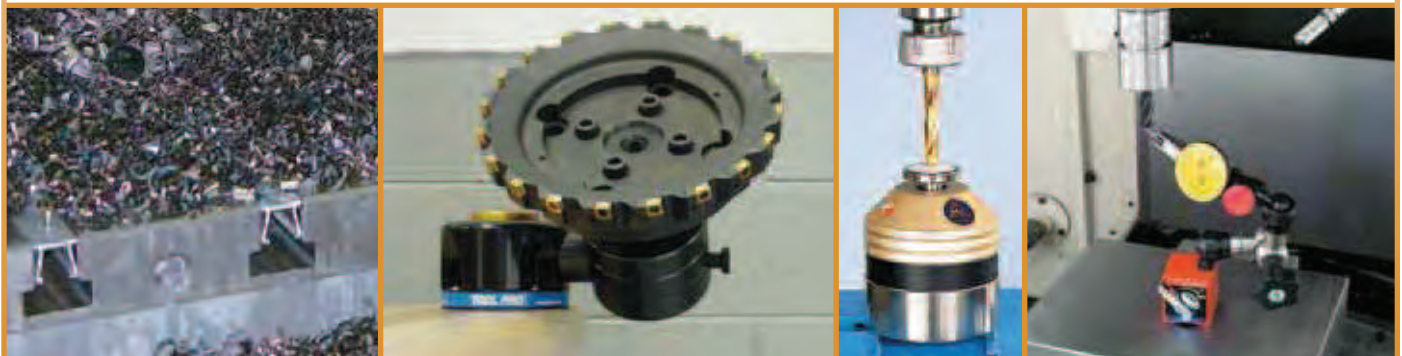

**TOOL PRO**

**TEKUSA**

**mptec<sub>ag</sub>**

**LANG**



### TOOL ASSEMBLY DEVICES

Tool Pro .....	Pg. 4
Kombi Grip	
Tooling Mate .....	Pg. 5
ST Lock	
Collet Ejector .....	Pg. 6



### TOOLING CLEANERS

$\alpha$ Taper Cleaner	
$\alpha$ Tooling Cleaner	
HSK External Taper Cleaner .....	Pg. 7
TK Cleaner	
$\alpha$ Wiper Cleaner .....	Pg. 8



### SPINDLE CLEANERS

ISO Taper Cleaner	
Morse Taper Cleaner	
HSK Taper Cleaner	
Polygon Taper Cleaner .....	Pg. 9



### MEASURING DEVICES

Base Master	
Base Master Gold 50 & 100 .....	Pg. 10
Base Master Micro	
Base Master Mini	
Tool Master .....	Pg. 11
Point Master .....	Pg. 12
Accu Center .....	Pg. 13
Dial Indicator Stands .....	Pg. 14-16
Dyna Test .....	Pg. 17
Dyna Force .....	Pg. 18
ATC Alignment Tool .....	Pg. 19
Level Master .....	Pg. 20



### IN-PROCESS MACHINE DEVICES

CCD Camera	
BIG-PLUS® Cleaner .....	Pg. 21
Chip & Coolant Fan .....	Pg. 22
T-Slot Clean .....	Pg. 23

## Tool Pro

The Tool Pro is a unique tool holding device for the assembly and disassembly of tapered V-flange tooling and modular tooling systems. Depressing the large gold button permits the adapter to rotate 360° and lock in 45° increments, allowing convenient access for all operations in one setup. Tightening torque for tool clamping can be applied in a downward motion, rather than horizontally, allowing the Tool Pro to be installed on tool carts. Tools are simply lowered into the tool pot and automatically clamped into place with a spring loaded pin that locates precisely into the V-groove of the tool holder. With the Tool Pro, you reduce damage to your expensive tool holders, shanks and machine spindles while providing a safe working environment for your tool assembly operators—advantages which pay off very quickly!



### Standard



#### Steep Taper

Taper Size	Catalog Number
30	31.300.001
35	31.300.000
40	31.300.002
45	31.300.003
50	31.300.004
60	31.300.020

#### HSK Taper

Taper Size	Catalog Number
32A	31.300.017
40A	31.300.015
50A	31.300.008
63A	31.300.006
100A	31.300.005
125A	31.300.029

• HSK Type E/F, VDI and Polygon taper also available

### Vario



Quick-change system uses one permanently mounted base unit and multiple adapters for different types and sizes of tool shanks.

#### Steep Taper

Taper Size	Catalog Number
30	31.300.110
35	31.300.111
40	31.300.112
45	31.300.113
50	31.300.114

#### HSK Taper

Taper Size	Catalog Number
32A	31.300.130
40A	31.300.131
50A	31.300.132
63A	31.300.133
80A	31.300.134
100A	31.300.135

#### Polygon Taper

Taper Size	Catalog Number
C3	31.300.153
C4	31.300.154
C5	31.300.155
C6	31.300.156
C8	31.300.158

• Base unit must be ordered separately (Catalog Number 31.300.100)  
• HSK Type E/F and VDI also available

### Spin

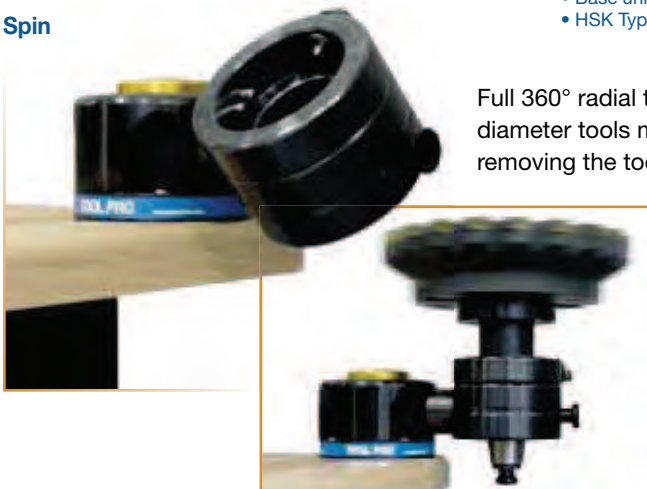

Full 360° radial tool rotation, while clamped, permits easy access to large diameter tools making it ideal for changing inserts on large face mills without removing the tool from the drive keys. Tools can be locked at increments of 30° by engaging an index pin. The adapter can also be rotated 360° and locked into any position in increments of 45° to further improve ergonomic handling of any size and length of tool.

#### Steep Taper

Taper Size	Catalog Number
40	31.300.202
50	31.300.204
60	31.300.206

#### HSK Taper

Taper Size	Catalog Number
63A	31.300.214
100A	31.300.216
125A	31.300.217

• Polygon taper also available

## Kombi Grip

Innovative two way clutch and needle roller clamping system assures secure clamping at the tool flange periphery. Safe design eliminates any possibility of damage to the shank taper during the tightening process.

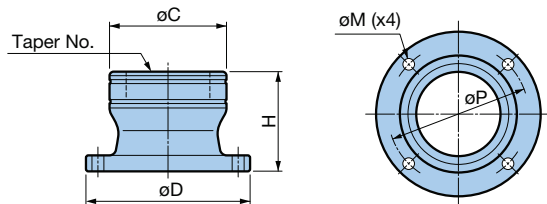

Catalog Number	HSK No. (Form A/E/F)	Polygon Coupling No.	øC	øD	H	øP	øM
KG25R	25	—	1.890	3.110	2.559	2.441	.276 M6 or UNC 1/4
KG32R	32	C3	2.165	3.346		2.717	
KG40R	40	C4	2.480	3.661	2.756	3.031	
KG50R	50	C5	2.953	4.134		3.504	
KG63R	63	C6	3.465	4.862	2.953	4.154	.354 M8 or UNC 5/16
KG80R	80	C8	4.213	5.591	3.543	4.882	
KG100R	100	—	5.000	6.378	3.937	5.669	



**Kombi Grip must be securely fixed to a bench with 4 mounting bolts.**

• Mounting bolts (4 pcs.) must be ordered separately

## Tooling Mate

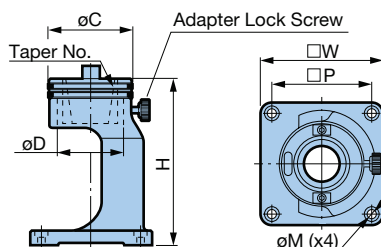

### Replaceable Adapter

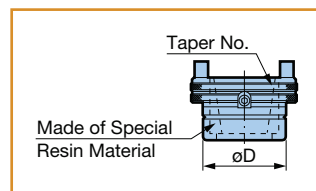

Catalog Number	CV/BT No.	øC	øD	H	øW	øP	øM	Adapter Model
TMS40-30	30	2.992	2.362	5.906	4.331	3.543	.276 M6	TMA40-30
TMS40-40	40							TMA40-40
TMS50-40	40	4.134	3.465	7.480	6.299	5.118	.354 M8	TMA50-40
TMS50-50	50							TMA50-50

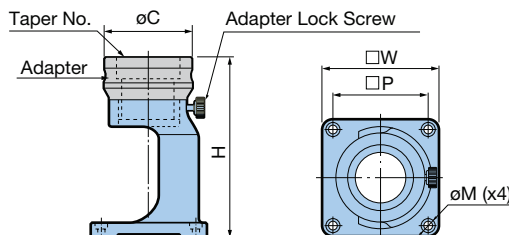

- 1 adapter is included
- Adapters can be ordered individually
- Adapter Lock Screw is available as a spare part (Model: RTM0615)
- Mounting bolts (4 pcs.) must be ordered separately



**Tooling Mate must be securely fixed to a bench with 4 mounting bolts.**

Catalog Number	HSK No.	Polygon Coupling No.	øC	H	øW	øP	øM	Adapter Model
TMS40-32R	32	C3	2.992	6.496	4.331	3.543	.276 M6 or UNC 1/4	TMA40-32R
TMS40-40R	40	C4						TMA40-40R
TMS40-50R	50	C5						TMA40-50R
TMS40-63R	63	C6	3.425	6.772	6.299	5.118	.354 M8 or UNC 5/16	TMA40-63R
TMS50-80R	80	C8	4.488	8.465				TMA50-80R
TMS50-100R	100	—	4.882	8.622				TMA50-100R

## ST Lock

Ideal fixture for the setup of cylindrical shank tool holders. Clamps  $\phi 20$ , 25 & 32mm shanks by replacing the sleeve.

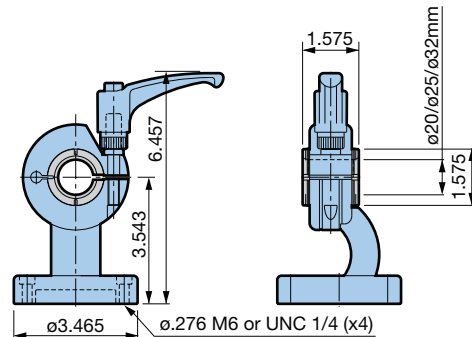

Catalog Number
<b>STL40</b>

- 1 pc. each of  $\phi 20$ , 25 & 32mm sleeves are included
- Mounting bolts (4 pcs.) must be ordered separately



**ST Lock must be securely fixed to a bench with 4 mounting bolts.**

## Collet Ejector

Collet Ejector can easily and quickly insert/remove small sizes of New Baby Collets from Mega Nuts & New Baby Nuts.



### New Baby Collet

Catalog Number	Nut	Collet
<b>NBC6-CE</b>	MGN6, NBN6	NBC6
<b>NBC8-CE</b>	MGN8, NBN8	NBC8
<b>NBC10-CE</b>	MGN10, NBN10	NBC10
<b>NBC13-CE</b>	MGN13, NBN13	NBC13

### New Baby End Mill Collet

Catalog Number	Nut	Collet
<b>NBC6E-CE</b>	MGN6, NBN6	NBC6E
<b>NBC8E-CE</b>	MGN8, NBN8	NBC8E
<b>NBC10E-CE</b>	MGN10, NBN10	NBC10E
<b>NBC13E-CE</b>	MGN13, NBN13	NBC13E

#### How to Insert a Collet

1. Insert the collet into the Collet Ejector. Then insert it into the nut.

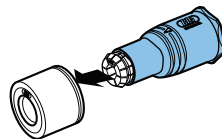

2. Depress the piston and remove the Collet Ejector.

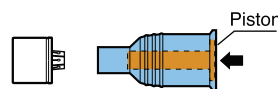

#### How to Remove a Collet

1. Tilt the Collet Ejector as shown in the picture to remove the collet from the nut.

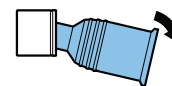

2. Depress the piston and the collet will be removed.

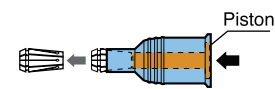

## α Taper Cleaner

Maintain the accuracy of high precision collet chucks by cleaning the internal collet taper.

### Mega Micro Chucks

Catalog Number	Chuck Body
SC-NBC3S	MEGA3S
SC-NBC4S	MEGA4S
SC-NBC6S	MEGA6S

### Mega New Baby & New Baby Chucks

Catalog Number	Chuck Body
SC-NBC6	MEGA6N, NBS6
SC-NBC8	MEGA8N, NBS8
SC-NBC10	MEGA10N, NBS10
SC-NBC13	MEGA13N, NBS13
SC-NBC16	MEGA16N, NBS16
SC-NBC20	MEGA20N, NBS20



### Mega E Chucks

Catalog Number	Chuck Body
SC-MEC6	MEGA6E
SC-MEC8	MEGA8E
SC-MEC10	MEGA10E
SC-MEC13	MEGA13E

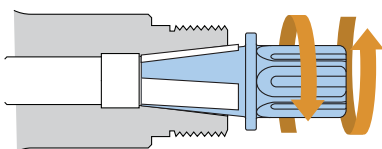

### ER Collet Chucks



Catalog Number	Chuck Body
SC-MER11	ER11
SC-MER16	ER16
SC-MER20	ER20
SC-MER25	ER25
SC-MER32	ER32

## α Tooling Cleaner

For the cleaning of both mating surfaces of BIG-PLUS® tool holders, which require absolute cleanliness for optimum performance.

Oil and particles on both the taper and flange of 7/24 taper shanks are easily removed.

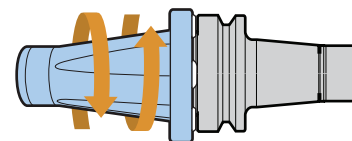

Catalog Number	Taper No.
SCE-30	No. 30
SCE-40	No. 40

## HSK External Taper Cleaner

Reliable and indispensable taper cleaners for the efficient cleaning of HSK tool holder shanks. Cleaning strips positioned at well spaced intervals will remove even large residual particles. Sturdy construction with high oil and grease resistance.



Catalog Number	Description	Taper No.
20.580.041	Taper Cleaner w/ Handy Cap	HSK40
20.580.042	Taper Cleaner w/ Cylindrical Handle	
20.580.051	Taper Cleaner w/ Handy Cap	HSK50
20.580.052	Taper Cleaner w/ Cylindrical Handle	
20.580.064	Taper Cleaner w/ Handy Cap	HSK63
20.580.065	Taper Cleaner w/ Cylindrical Handle	
20.580.081	Taper Cleaner w/ Handy Cap	HSK80
20.580.082	Taper Cleaner w/ Cylindrical Handle	
20.580.101	Taper Cleaner w/ Handy Cap	HSK100
20.580.102	Taper Cleaner w/ Cylindrical Handle	

## TK Cleaner

It is very difficult to remove oil and chips stuck to clamping bores, even with a wiping cloth or air spray. TK Cleaner perfectly cleans the clamping bore of a tool holder in a very simple manner to maintain the high performance of tool holders. Perfect for hydraulic chucks, milling chucks and shrink fit holders.

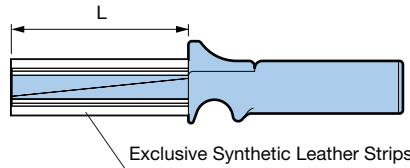
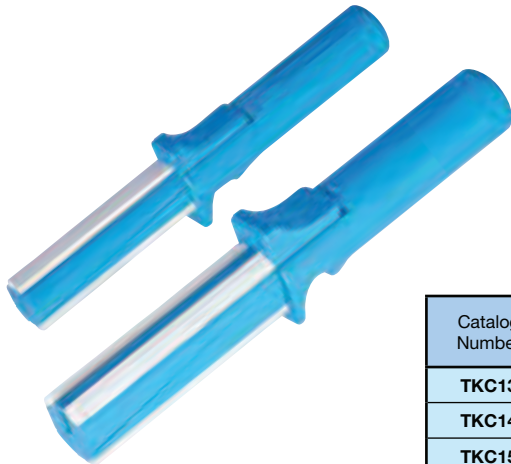

Catalog Number	Bore $\phi$ (mm)	Bore $\phi$ (in)	Cleaning Length L	Leather Strip Qty.
<b>TKC13</b>	13	.500	2.362	2
<b>TKC14</b>	14	—		
<b>TKC15</b>	15	—		
<b>TKC16</b>	16	.625	2.756	2
<b>TKC18</b>	18	—		
<b>TKC20</b>	20	.750		
<b>TKC25</b>	25	1.000	3.150	3
<b>TKC32</b>	32	1.250	3.937	4
<b>TKC40</b>	40	—		
<b>TKC42</b>	42	—		

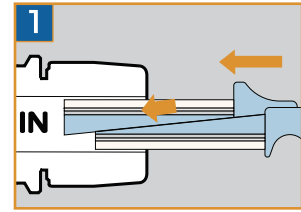

Slide the upper section forward to reduce diameter and insert in the clamping bore.

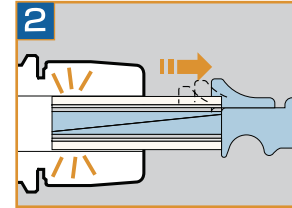

Spring action draws back the sliding section when released so the cleaning strips contact the bore surface.

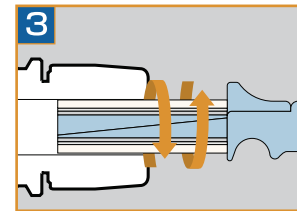

Rotate and remove the TK Cleaner to clear oil and particles.

## $\alpha$ Wiper Cleaner

Easy cleaning of smaller cylindrical bores by simply inserting and removing before cutting tool insertion. Perfect for hydraulic chucks and shrink fit holders.



**AWC1/4**  
**AWC6**

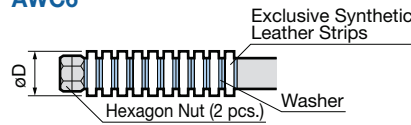

**AWC5/16 - AWC 9/16**  
**AWC7-12**

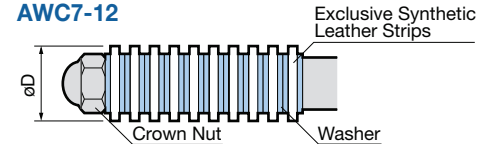

### Inch Style

Catalog Number	$\phi D$
<b>AWC1/4</b>	.250
<b>AWC5/16</b>	.312
<b>AWC3/8</b>	.375
<b>AWC7/16</b>	.437
<b>AWC1/2</b>	.500
<b>AWC9/16</b>	.562

### Metric Style

Catalog Number	$\phi D$
<b>AWC6</b>	6mm
<b>AWC7</b>	7mm
<b>AWC8</b>	8mm
<b>AWC9</b>	9mm
<b>AWC10</b>	10mm
<b>AWC11</b>	11mm
<b>AWC12</b>	12mm

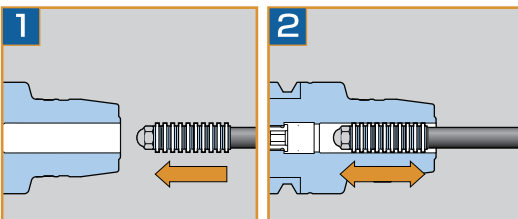



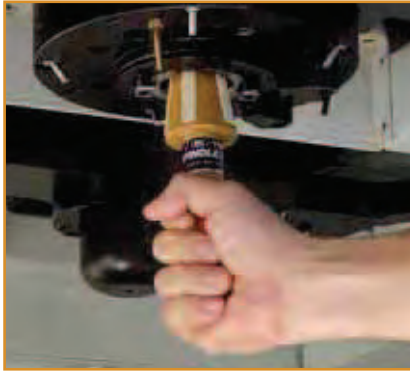

## Spindle Cleaners

The unbeatable tool to ensure absolute cleanliness of tapered spindles, which maintains the precision and prolongs the life of your expensive machine tools, cutting tools and tool holders.

- Robust construction with high oil and grease resistance
- Plastic injection molded core with fluted locations for cleaning strips ensures accurate sizing and cleaning efficiency
- Cleaning strips will maintain adhesion to the taper core due to inset location even under scrubbing action
- Cleaning strips positioned at well spaced intervals to remove even large residual particles
- A quality control product

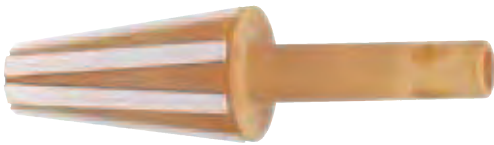

### ISO Taper (With Pull Stud Recess)

Catalog Number	Description	Taper No.
20.580.220	ISO20 Spindle Cleaner	ISO20
20.580.230	ISO30 Spindle Cleaner	ISO30
20.580.240	ISO40 Spindle Cleaner	ISO40
20.580.245	ISO45 Spindle Cleaner	ISO45
20.580.250	ISO50 Spindle Cleaner	ISO50



### Morse Taper

Catalog Number	Description	Taper No.
20.580.001	Morse Taper #1 Spindle Cleaner	MT1
20.580.002	Morse Taper #2 Spindle Cleaner	MT2
20.580.003	Morse Taper #3 Spindle Cleaner	MT3
20.580.004	Morse Taper #4 Spindle Cleaner	MT4
20.580.005	Morse Taper #5 Spindle Cleaner	MT5
20.580.006	Morse Taper #6 Spindle Cleaner	MT6



### HSK Taper

Catalog Number	Description	Taper No.
20.580.025	HSK25 Spindle Cleaner	HSK25
20.580.032	HSK32 Spindle Cleaner	HSK32
20.580.040	HSK40 Spindle Cleaner	HSK40
20.580.050	HSK50 Spindle Cleaner	HSK50
20.580.063	HSK63 Spindle Cleaner	HSK63
20.580.080	HSK80 Spindle Cleaner	HSK80
20.580.100	HSK100 Spindle Cleaner	HSK100
20.580.125	HSK125 Spindle Cleaner	HSK125



### Polygon Taper

Catalog Number	Description	Taper No.
SC-C3	Polygon Taper C3 Spindle Cleaner	C3
SC-C4	Polygon Taper C4 Spindle Cleaner	C4
SC-C5	Polygon Taper C5 Spindle Cleaner	C5
SC-C6	Polygon Taper C6 Spindle Cleaner	C6
SC-C8	Polygon Taper C8 Spindle Cleaner	C8



**Base Master Series**

Precision touch sensor to define work offsets and tool lengths.

- LED lamp illuminates at exactly 2" from the reference surface
- Repeatability of  $\pm 0.0004"$
- Safety over-travel of sensor plate prevents damage to tooling
- Magnetic base mounts vertically, horizontally, or at any angle
- Battery life of 10 hours (continuous use)

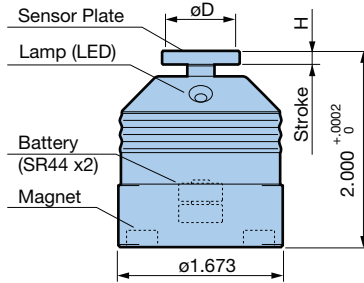

**Base Master**

For cutting tools, workpieces and machine tools using conductive materials.



Height Accuracy	2.000 $\begin{smallmatrix} +.0002 \\ 0 \end{smallmatrix}$
Measurable Pressure	3N
Min. Measurable Tool Diameter	.039
Weight	.51 lbs

Catalog Number	Sensor Plate Diameter øD	Sensor Plate Material	Stroke H
<b>BM-2</b>	.709	Steel	.118

- BM-2 will not work with non-conductive cutting tools, workpieces, or machine tools
- 50mm metric units available upon request

**Base Master Gold 50 & 100**

For all materials, including non-conductive cutting tools, workpieces, and machine tools.



Height Accuracy	2.000 $\begin{smallmatrix} +.0002 \\ 0 \end{smallmatrix}$
Measurable Pressure	3N
Min. Measurable Tool Diameter	.039
Weight	.53 lbs

Catalog Number	Sensor Plate Diameter øD	Sensor Plate Material	Stroke H
<b>BM-2G</b>	.551	Ceramic	.118

- 50mm metric units available upon request



Height Accuracy	100mm $\begin{smallmatrix} +.01mm \\ 0 \end{smallmatrix}$
Measurable Pressure	2N
Min. Measurable Tool Diameter	.039
Weight	.79 lbs

Catalog Number	Sensor Plate Diameter øD	Sensor Plate Material	Stroke H
<b>BM-100G</b>	28mm	Ceramic	10mm

## Base Master Micro

Light pressure activation for small tools. Suitable for all materials, including non-conductive cutting tools, workpieces and machine tools. Preset  $\phi.002''$  tools for considerable reduction of set-up time.



Height Accuracy	2.000 $\begin{smallmatrix} +.0002 \\ 0 \end{smallmatrix}$
Measurable Pressure	.3N
Min. Measurable Tool Diameter	.002
Weight	.53 lbs



Catalog Number	Sensor Plate Diameter $\phi D$	Sensor Plate Material	Stroke H
<b>BM-2M</b>	.276	Ceramic	.039

- For cutting tools under  $\phi.039''$ , feed slowly and touch the sensor plate carefully
- 50mm metric units available upon request

## Base Master Mini

World's smallest body diameter ( $\phi 20\text{mm}$ ). Best suited for measurements in limited space and complicated shapes. High intensity blue LED indication when the offset position is detected. For all materials, including non-conductive cutting tools, workpieces and machine tools.



Height Accuracy	40mm $\begin{smallmatrix} +.005\text{mm} \\ 0 \end{smallmatrix}$
Measurable Pressure	1.8N
Min. Measurable Tool Diameter	.0039
Weight	.12 lbs



Catalog Number	<b>BMM-20</b>
----------------	---------------

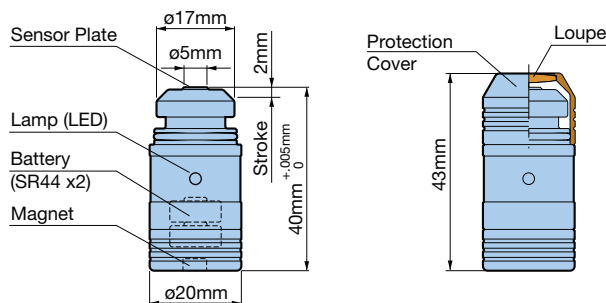

Protection Cover with Magnifier (5x)



## Tool Master

Precision touch sensor to define work offsets and tool lengths.

- Large dial that is easy to view and includes approach LED lamp and sound
- Adjustable height
- Magnetic base mounts vertically, horizontally, or at any angle
- For all materials, including non-conductive cutting tools, workpieces and machine tools



Height	100mm (after compressed by approx. 2mm)
Stroke	5mm
Measurable Pressure	6N
Weight	2.65 lbs

Dial Gauge	Dial Graduation	.01mm
	Indication Tolerance	.015mm
	Repeatability	.005mm
	Return Tolerance	.005mm

Catalog Number	<b>TM-100</b>
----------------	---------------

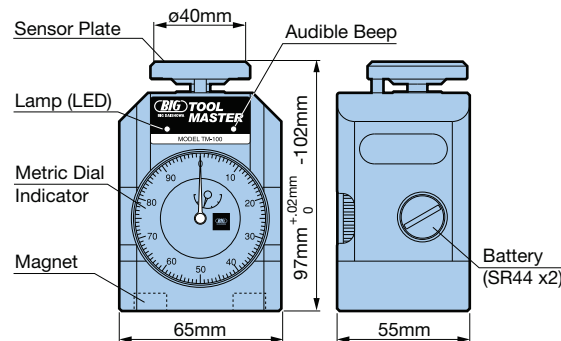



### Point Master Series

Precision 3-D touch sensor to quickly find edges and measurement locations.

- Repeatability of  $\pm .00008"$  with safety over-travel
- Replaceable stylus for different applications (M3 thread)
- LED lamp illuminates when the stylus touches the workpiece
- For use with conductive cutting tools, workpieces and machine tools

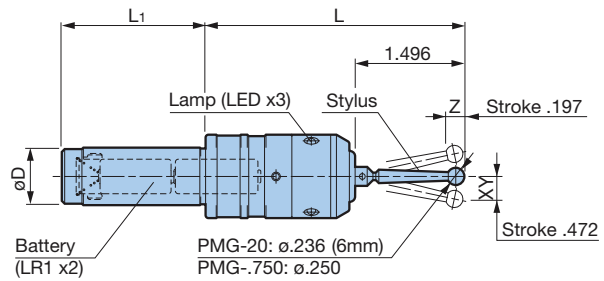

### Cylindrical Shank Taper

Catalog Number	$\phi D$ (h7)	L	L1	Standard Stylus
PMG-20	20mm	3.543	1.969	ST38-6P
PMG-.750	.750			ST38-.25P

• Above table indicates the specifications when using standard stylus

Fig. 1

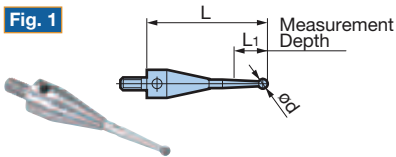
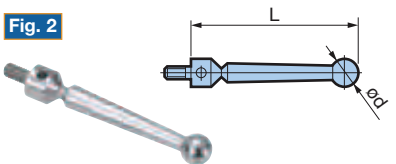

Fig. 2



### Additional Stylus

Catalog Number	Fig.	$\phi d$	L	L1	Material
ST28-1P	1	1mm (.039)	1.102	.079	Carbide
ST28-2P		2mm (.079)		.315	
ST28-3P	2	3mm (.118)	1.496	—	Stainless Steel
ST28-4P		4mm (.157)		—	
ST38-6P		6mm (.236)		—	
ST38-.25P		.250		—	

### Application Examples

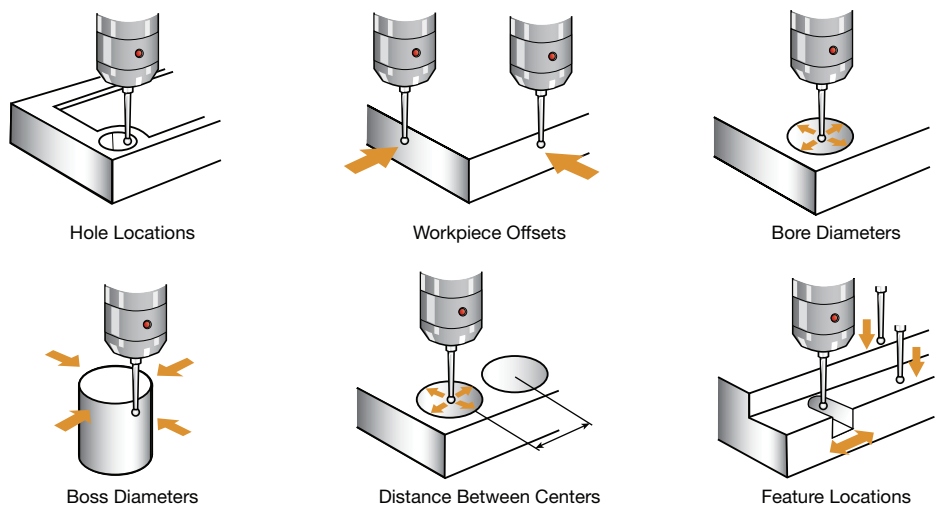

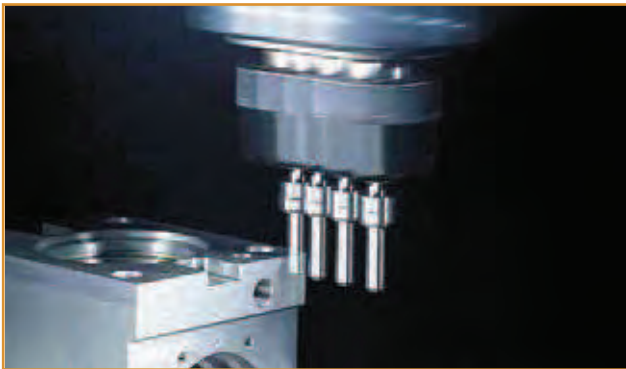

**Accu Center**

Precision edge finder suitable for all materials.

- Repeatability of .00012"
- Hard chrome plated cylindrical stylus for extended life
- Not for use with horizontal machine tools

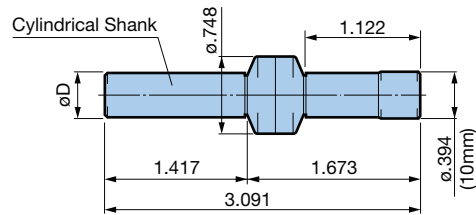
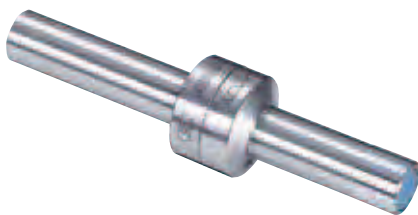

Catalog Number	øD
ACCU-C10	10mm

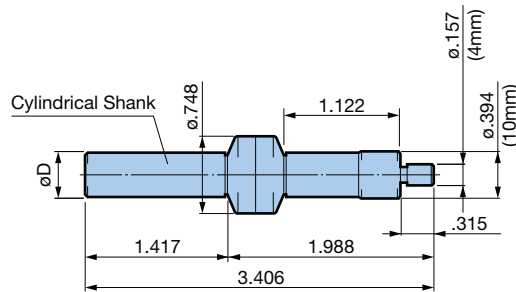
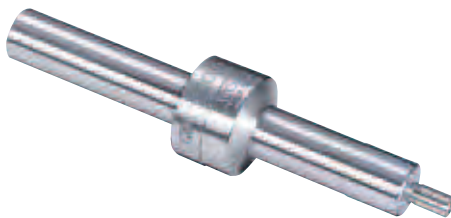

Catalog Number	øD
ACCU-C104	10mm

**Operation Instructions**

**1**  
Clamp Accu Center in a collet chuck.

**2**  
Move the stylus off center, and rotate between 400 and 600 RPM.

**3**  
Bring the tool into contact with the workpiece and advance slowly until the stylus lines up with the body.

**4**  
If advanced too far the stylus will again move off center. Be sure to compensate location for half the stylus diameter.

**Dial Indicator Stands**

Articulated stands for the demanding user, offering the highest positioning precision and exact measurements in the  $\mu\text{m}$  range.

- High clamping force thanks to a strong internal cam structure of steel components.
- Extremely flexible with 360 degrees freedom of positioning controlled by one progressive clamping star grip
- Ideal design for use in measurement, inspection (quality control) and machining
- Ultra strong magnet holds stand firmly in place
- Each stand is equipped standard with (1) magnet, (2) extension arms, (1) DGH dove-tail adapter and (1) cylindrical gauge adapter ( $\varnothing.375"$ )

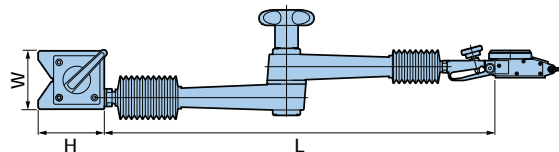
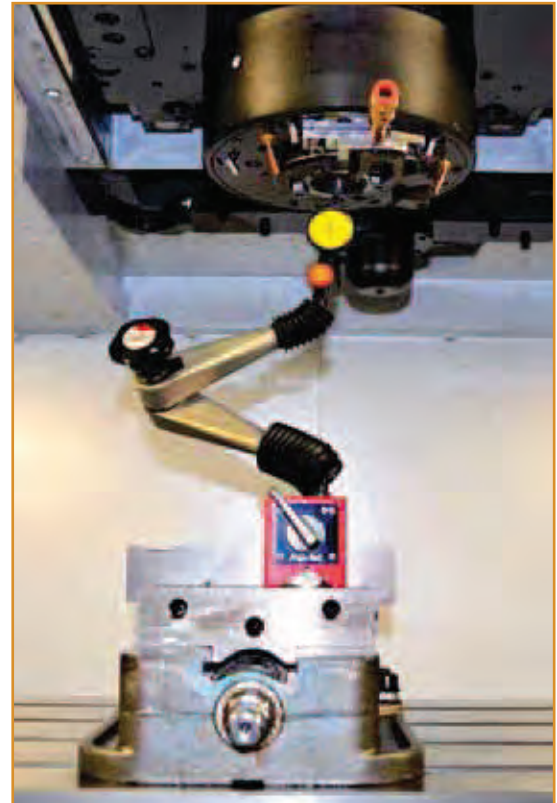

**Type MU/F**

Catalog Number	Adapter	Arm Extension Capacity L (From Magnet Top)	Magnet Dimensions W x H x D	Load Capacity Approx.
20.510.102	DGH2	13.937 (354mm)	2.087 x 2.362 x 2.677 (53mm x 60mm x 68mm)	200 lbs. (90 kg)
20.510.103	DGH3			
20.510.104	DGH4			

**DIAL GAUGE ADAPTERS PG. 15**

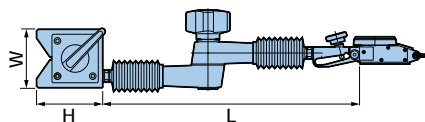

**Type SU/F**

Catalog Number	Adapter	Arm Extension Capacity L (From Magnet Top)	Magnet Dimensions W x H x D	Load Capacity Approx.
20.520.102	DGH2	9.173 (233mm)	2.087 x 2.362 x 1.417 (53mm x 60mm x 36mm)	110 lbs. (50 kg)
20.520.103	DGH3			
20.520.104	DGH4			

**DIAL GAUGE ADAPTERS PG. 15**



**Type MU/FS**

- Dial indicator stand with cast iron base
- Specifications of clamp arm same as type MU/F
- Base with 3-point sliding contact and one flat side for parallel measurement

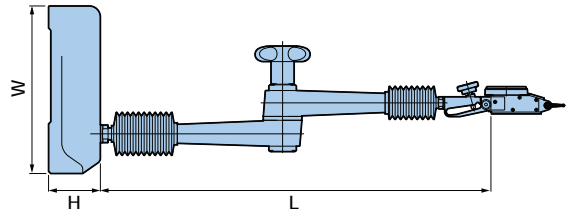

Catalog Number	Adapter	Arm Extension Capacity L (From Magnet Top)	Base Size W x H x D	Weight (Not Including Arm)
20.530.102	DGH2	13.937 (354mm)	5.984 x 1.850 x 5.984 (152mm x 47mm x 152mm)	6.6 lbs. (3 kg)
20.530.103	DGH3			
20.530.104	DGH4			

- 100mm extension arm available to increase work radius (Catalog Number 20.580.513)



**Type SG**

- Articulated clamping arm for gluing, welding or soldering
- Quickly solves all tricky angling problems
- Simultaneous tensioning action

Catalog Number	Description	Extension Number	Extension Length
20.540.001	Type SG 3/4 Arm with One Tension Clamps	No. 3	2.953 (75mm)
		No. 4	3.937 (100mm)
20.540.002	Type SG 4/4 Arm with Two Tension Clamps	No. 4	3.937 (100mm)

**Dial Gauge Adapters**

A significant disadvantage of current models of dial gauge adapters is that their construction, out of two or more components, results in an unavoidable play or slackness in the adapter. The solution to this challenge is a new type of adjustable adapter consisting of a single shaped part. This part forms two opposing legs whose relative position can be fine-adjusted by means of a tensioning screw (DGH3). A special micro model (DGH4) with a fine-adjustment rocker is also available for measurement precision in the  $\mu\text{m}$  range. All adapters include a  $\text{\textcircled{0.375}}$  cylindrical gauge adapter.

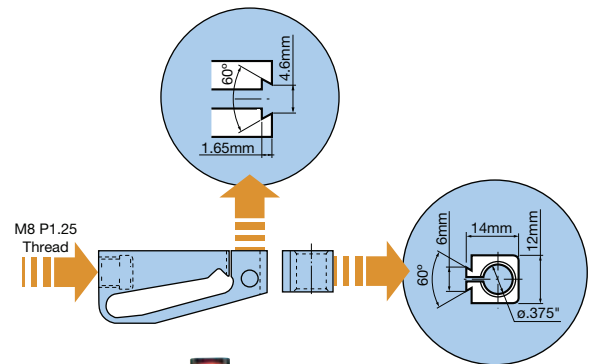

**DGH2**

Catalog Number
20.580.402

- Basic model (without fine-tuning screw)



**DGH3**

Catalog Number
20.580.403

- Standard adapter for MU and SU stands

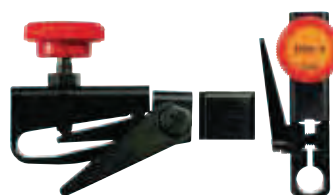

**DGH4**

Catalog Number
20.580.404

- Precision micro model



**Cylindrical Gauge Adapter**

Catalog Number	Clamping $\text{\textcircled{0}}$
20.580.501	.250
20.580.502	.375
20.580.511	4mm
20.580.512	8mm



## Dial Indicator Stands — Accu Mini Mini

- Very rigid, short and sturdy stand with internal steel cam action components
- Clamping of articulating arms by one progressive clamping star grip
- Ultra strong magnet holds stand firmly in place
- Optional models can be supplied with straight shank (ø12 or 20mm) or HSK shank (E25, E32) instead of the magnet to go directly into a machine tool spindle
- Each stand is equipped standard with a dove-tail adapter; cylindrical gauge adapters are optional items (see Pg. 15)

### Magnet Type

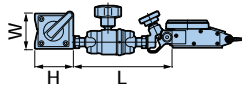

Catalog Number	Magnet Dimensions W x H x D	L
<b>AMM-M</b>	1.260 x 1.378 x 1.378 (32mm x 35mm x 35mm)	3.543

**CYLINDRICAL GAUGE ADAPTERS PG. 15**

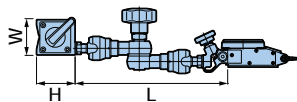

Catalog Number	Magnet Dimensions W x H x D	L
<b>AML-M</b>	1.260 x 1.378 x 1.378 (32mm x 35mm x 35mm)	5.433

**CYLINDRICAL GAUGE ADAPTERS PG. 15**

### Straight Shank Type

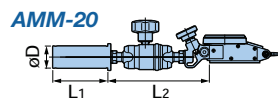
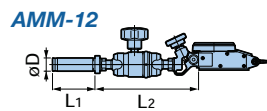

Catalog Number	øD	L1	L2
<b>AMM-12</b>	12mm	1.535	3.701
<b>AMM-20</b>	20mm	1.969	3.622

**CYLINDRICAL GAUGE ADAPTERS PG. 15**

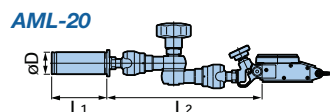
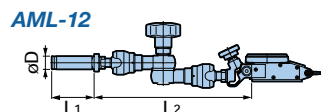

Catalog Number	øD	L1	L2
<b>AML-12</b>	12mm	1.535	5.630
<b>AML-20</b>	20mm	1.969	5.551

**CYLINDRICAL GAUGE ADAPTERS PG. 15**

### HSK Shank Type

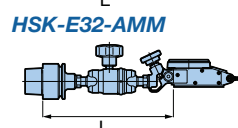
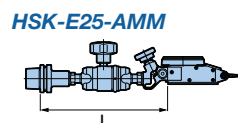

Catalog Number	L
<b>HSK-E25-AMM</b>	4.567
<b>HSK-E32-AMM</b>	4.685

**CYLINDRICAL GAUGE ADAPTERS PG. 15**



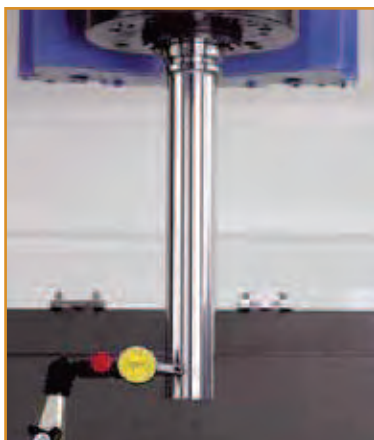

## Dyna Test

The cause of machine tool runout stems from wear of the spindle bearings. Regular inspection with Dyna Test helps identify potential problems, and can reduce downtime and costly repairs of the machine tool spindle.

- Precision test bar for static runout accuracy
- Produced under a strict quality control process; calibration certificate available upon request as per ISO 9000 requirements

Precision Standards of BIG Daishowa Test Arbors	
Runout	0.002mm (.00008")
Roundness	0.001mm (.00004")
Cylindricity	0.003mm (.00012")
Roughness	Rz: 0.6 μm (.00002")
Taper Contact	AT1
Diameter Tol.	±0.005mm (.0002")

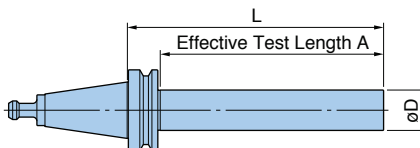

**Included:**  
Dyna Test & Aluminum Storage Case

### BCV (ASME B5.50)

Catalog Number	L	A	øD
BCV40-2.000-L13.5SD	13.500	12.500	2.000
BCV50-2.000-L13.5SD	13.500	12.500	

### BBT (MAS 403)

Catalog Number	L	A	øD
BBT30-32-L150	5.906	4.921	1.260
BBT30-32-L235	9.252	8.268	
BBT40-50-L200	7.874	6.693	1.969
BBT40-50-L350	13.780	12.598	
BBT50-50-L200	7.784	6.260	
BBT50-50-L360	14.173	12.559	

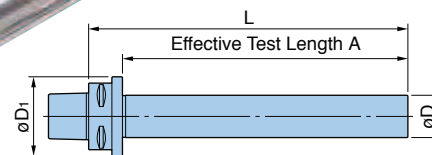
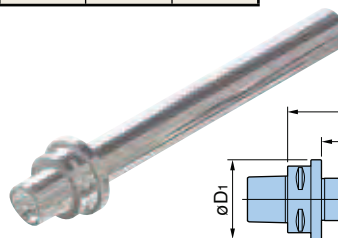
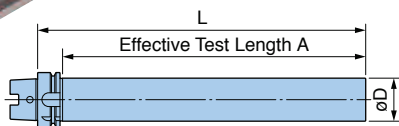
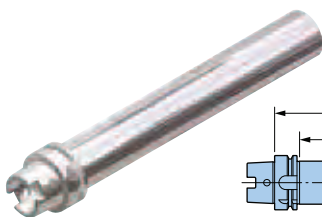

### HSK (ISO 12164/DIN 69893)

HSK Form	Catalog Number	L	A	øD
A	HSK-A40-32-L180SD	7.087	6.181	1.260
	HSK-A50-32-L240SD	9.449	8.307	
	HSK-A63-50-L200SD	7.874	6.732	1.969
	HSK-A63-50-L350SD	13.780	12.638	
	HSK-A100-50-L200SD	7.784	6.614	
	HSK-A100-50-L350SD	13.780	12.520	
E	HSK-E25-20-L175	6.890	6.417	.787
	HSK-E32-20-L180	7.087	6.220	
	HSK-E40-32-L180		6.181	1.260
	HSK-E50-32-L240	9.449	8.307	
F	HSK-F63-50-L200	7.874	6.732	1.969
	HSK-F63-50-L350	13.780	12.638	

### BIG CAPTO

Catalog Number	L	A	øD	øD1
C5-32-150	7.087	5.906	1.260	2.480
C5-32-215	9.646	8.465		
C5-32-250	11.024	9.843		
C6-40-150	7.165	5.906	1.575	2.953
C6-40-200	9.134	7.874		
C6-40-320	13.858	12.598		
C8-40-200	9.449	7.874		3.346
C8-40-320	14.173	12.598		

• BIG CAPTO is a licensed product from Sandvik Coromant Sweden

## Dyna Force

Machine tool maintenance is a necessity. Periodical measurement of the spindle retention force avoids unknown reduced rigidity, which leads to vibrations, loss of machining quality and shortened tool life. A full length taper stabilizes the value of measurements.

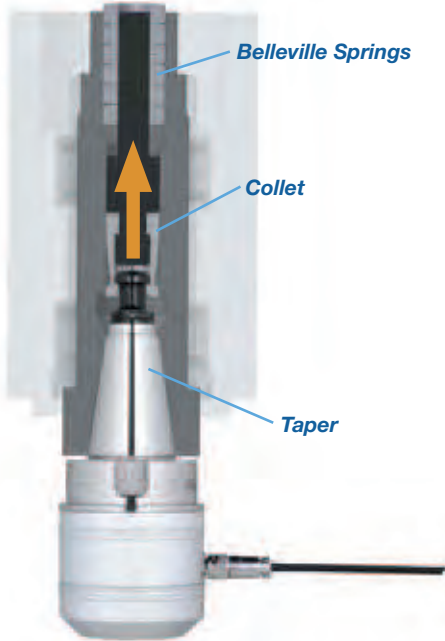

**Included:**  
Dyna Force, Plastic Storage Case, Display & Cable

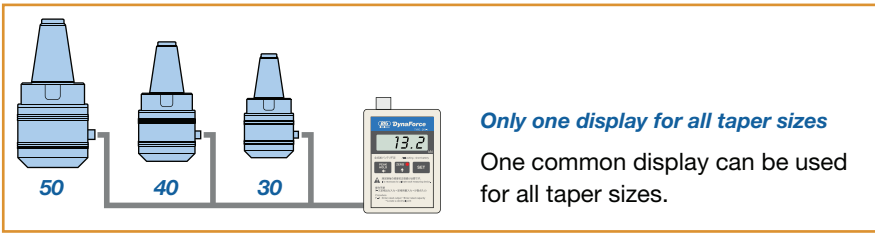

**Only one display for all taper sizes**  
One common display can be used for all taper sizes.

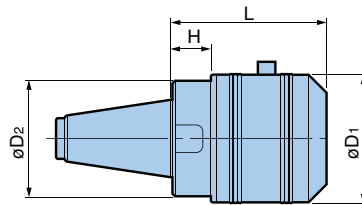

Fig. 1

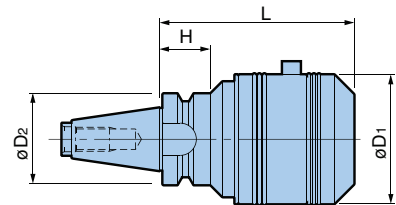

Fig. 2

Catalog Number	Contents of Set				Taper No.	Rated Capacity	øD1	øD2	L	H	Weight (lbs.)
	Measuring Device	Fig.	Display	Cable							
SNT30-DF10	NT30-DF10	1	DFA-1 (AA battery x2)	DFC-1 (1m)	30	10 kN (980 kgf)	2.559	2.283	3.150	.787	3.3
SBT30-DF10	BT30-DF10	2						1.811	2.858	1.024	3.5
SNT40-DF30	NT40-DF30	1			50	30 kN (2,940 kgf)	2.874	2.958	3.543	.945	5.5
SNT50-DF50	NT50-DF50	1				50 kN (4,900 kgf)	3.780	3.543	4.331	1.299	13.2
SNT50-DF30 ●	NT50-DF30	1				30 kN (2,940 kgf)	2.874	2.756	3.386	.787	8.6

- Each component is also available separately
- SBT30-DF10 is designed exclusively for machines not capable of automatic tool change
- SBT30-DF10 is suitable for BT/BBT30 machines only
- Pull stud bolt must be ordered separately, and for DIN, ISO, ANSI & CAT standard machines, an exclusive pull stud bolt for Dyna Force is required
- SNT50-DF30 marked ● indicates light-weight model
- Certificate of calibration and diagram of traceability system are available for a charge in order to maintain the reliability of the device

## Pull Stud Bolts for Dyna Force

An exclusive pull stud bolt is needed for machine spindles with DIN, ANSI or CAT tapers. Pull stud bolts in MAS and JIS standards can be used.

Standard No.	Taper No.		
	30	40	50
DIN 69872	DF-PDV30	DF-PDV40A	DF-PDV50A
ISO 7388	Type A	-	DF-PAV40
	Type B		
ANSI B5.50	DF-PAV30	DF-PAV40	DF-PAV50
ASME B5.50	DF-PCV30	DF-PCV40	DF-PCV50

**NEW!**

**ATC Alignment Tool**

Misalignment of the center between the machine tool spindle and ATC gripper may cause damage to the spindle taper when a tool holder is loaded into the spindle. A clamped tool holder under misalignment leads to increased runout, resulting in shorter life of machine tools and tool holders, as well as cutting tools. The ATC Alignment Tool can also be used for re-aligning the ATC gripper and tool magazine pots. Overall cost reduction is achieved by using equipment in good condition.

**How To Use**

1. Load the AL Shank in the machine spindle and mount the AL Flange on the ATC arm.
2. Insert the AL Plug into the AL Flange.
3. Rotate the AL Plug and read the highest and lowest values of the dial indicator. This direction is the eccentric direction. Half of the gap of the values is the eccentric amount.
4. Adjust the position of the ATC arm so that the front end of the AL Plug will be inserted into the AL Flange fully.

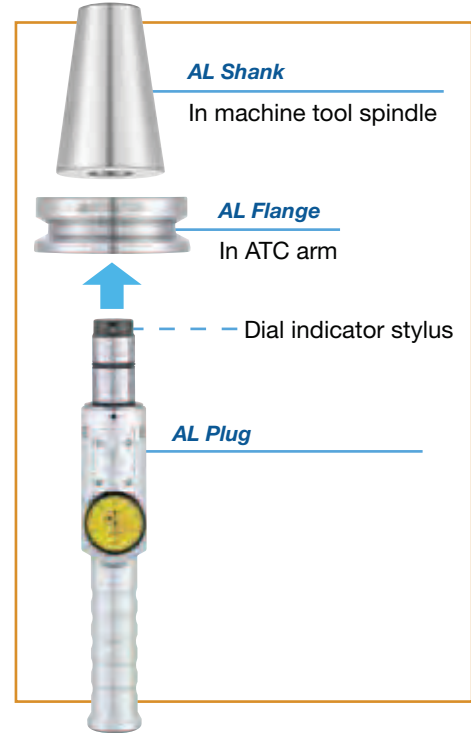

**Included:**  
ATC Alignment Tool & Plastic Storage Case

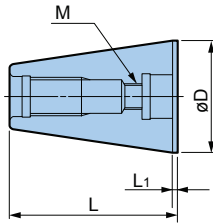

**AL Shank**

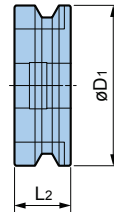

**AL Flange**

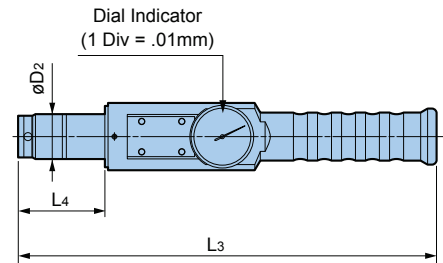

**AL Plug**

**CV Taper**

Catalog Number	øD	D1	D2	L	L1	L2	L3	L4	M
<b>CV40-ATC20</b>	1.750	2.500	.787	2.812	.123	.958	9.882	1.732	1/2"-13
<b>CV50-ATC28</b>	2.750	3.875	1.102	4.125	.123	1.301	10.276	2.126	5/8"-11

• DIN 7/24 taper spindle models available

**BT Taper**

Catalog Number	øD	D1	D2	L	L1	L2	L3	L4	M
<b>BT30-ATC18</b>	31.75mm	46mm	18mm	50.4mm	2mm	20mm	251mm	44mm	12mm
<b>BT40-ATC20</b>	44.45mm	63mm	20mm	67.4mm	2mm	25mm	251mm	44mm	12mm
<b>BT50-ATC28</b>	69.85mm	100mm	28mm	104.8mm	3mm	35mm	261mm	54mm	16mm

## Level Master

High precision device for the leveling of machine tool tables.

- Simultaneous 2-axis detection leveler
- LED and buzzer indication when leveling is complete
- Uses optical level sensor technology
- 10 micron per meter precision (.01mm/m)



*Simultaneous 2-axis detection saves the extra time & cost of using 2 levelers*

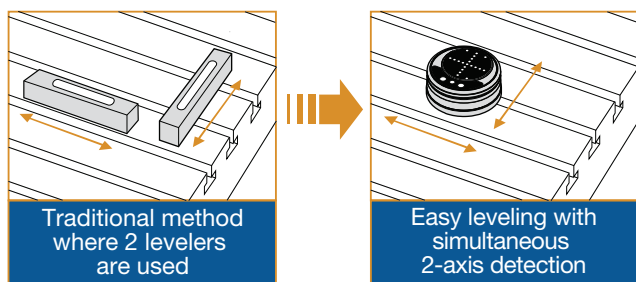

Catalog Number
<b>LVM-01</b>

Minimum Read Value	.01mm inclination/m
Power Source	Alkaline batteries (AAA x 4 pcs.)
Auto Power Off	30 minutes after power is turned on
Operational Temperature	32-104° F (Recommended 66° F ±9°)
Battery Life	50 hours
Dimensions	ø4.3 x 2.2 H
Weight	2.2 lbs

- In the case of high precision leveling, we recommend that you check the Level Master in advance on a reference level, such as a level block

*LED and buzzer indicates leveling completion*

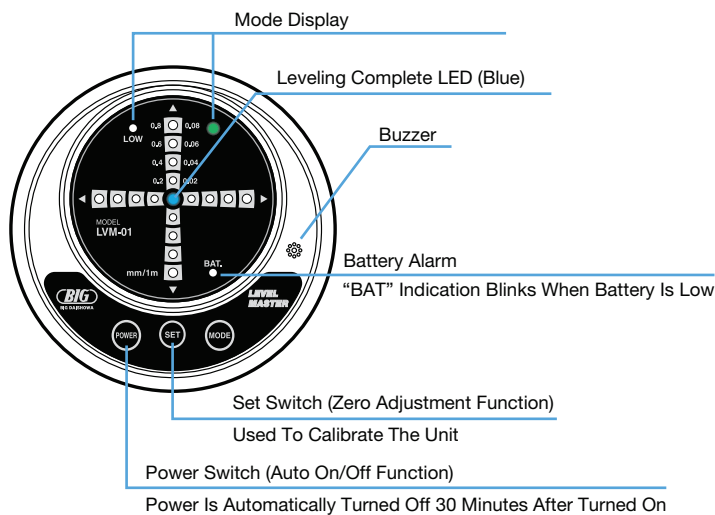
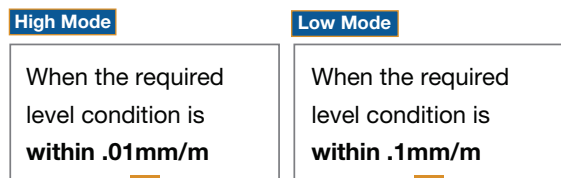

LED Status	Inclination
● LED (red) on:	over .08mm/m
● LED (red) blinking:	within .08mm/m
● LED (orange) blinking:	within .06mm/m
● LED (yellow) blinking:	within .04mm/m
● LED (green) blinking:	within .02mm/m
● LED (blue) blinking:	within .01mm/m

LED Status	Inclination
● LED (red) on:	over .8mm/m
● LED (red) blinking:	within .8mm/m
● LED (orange) blinking:	within .6mm/m
● LED (yellow) blinking:	within .4mm/m
● LED (green) blinking:	within .2mm/m
● LED (blue) blinking:	within .1mm/m



**Included:**  
 Level Master, Aluminum Storage Case, Alkaline Batteries (AAA x 4 pcs.),  
 Manual, Guarantee Certificate & Inspection Sheet

## CCD Camera

For visual monitoring and image capturing of a machine's inside and production line. An air spray nozzle eliminates any spots around the pin-hole camera lens. The signal cable is protected by a shielded tube.

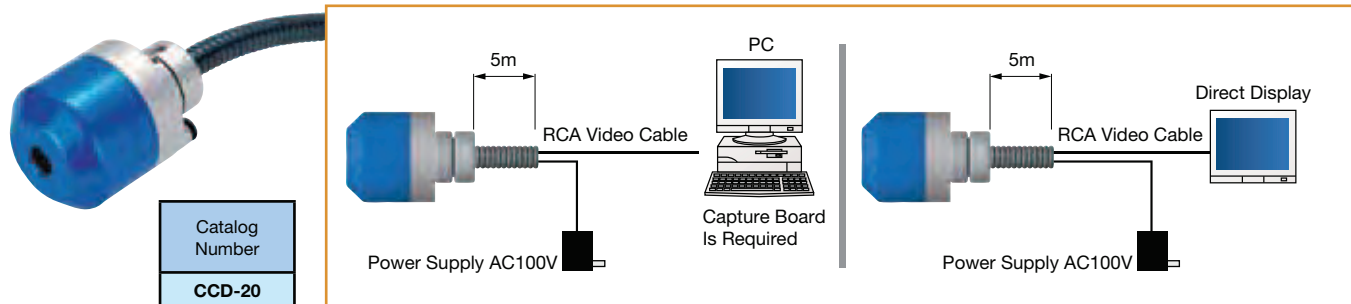

- M8 P1.25 thread on bottom of the CCD Camera is for adapting to indicator stands which offer ideal mounting and positioning inside machines

## BIG-PLUS® Cleaner

Blowing air cleans the BIG-PLUS® machine spindle face of all debris.

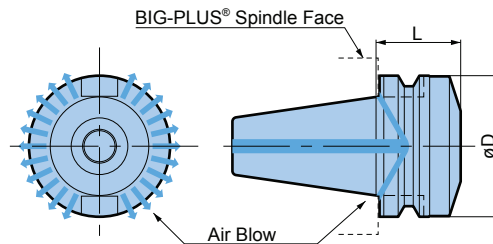

### BCV

Catalog Number	øD	L
<b>SCV40-ASC-1.750T</b>	2.480	1.750
<b>SCV50-ASC-2.5T</b>	3.875	2.480

### BBT

Catalog Number	øD	L
<b>SBT30-ASC-30T</b>	1.811	1.181
<b>SBT40-ASC-40T</b>	2.480	1.575
<b>SBT50-ASC-60T</b>	3.937	2.362

- When the cleaner is clamped into a BIG-PLUS® machine spindle, faces have 1mm (.039") clearance



**Clean-Tec Chip & Coolant Fan**

Fast, safe and automatic chip and coolant fans for in-process cleaning without stopping production. As the machine spindle turns, the blades deploy to provide high volume air cleaning power.

- Clean-Tec provides a safer and faster method of removing chips and coolant from your tables, fixtures and workpieces
- No more dripping coolant and flying chips from conventional air hose blasts
- A quieter workplace environment
- Less spindle downtime for cleaning results in increased profits
- Saves expensive compressed air
- Coolant-through shank for rinsing capability (coolant-through spindle required)

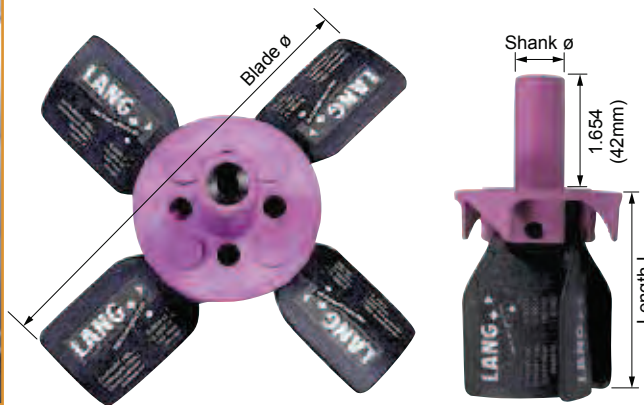
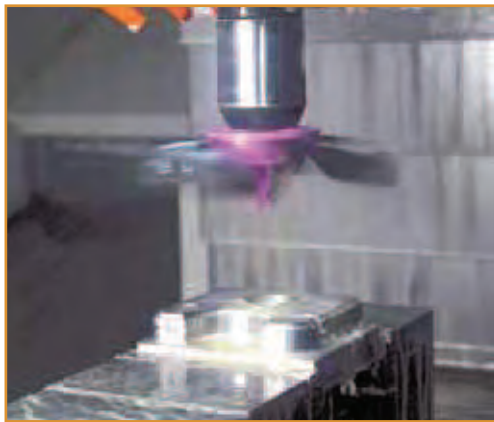

*Can be used in all enclosed horizontal & vertical machining centers*

Shank ø	Catalog Number	Description	Blade ø	Length L	Speed (RPM)	
					Min	Max
20mm	24.303.202	Chip Fan 20mm x 160mm	160mm	82mm (3.228)	6,000	12,000
	24.303.203	Chip Fan 20mm x 260mm	260mm	130mm (5.118)	5,000	8,000
	24.303.201	Chip Fan 20mm x 330mm	330mm	166mm (6.535)	5,000	8,000
.750	24.313.202	Chip Fan 3/4" x 160mm	6.299	3.228 (82mm)	6,000	12,000
	24.313.203	Chip Fan 3/4" x 260mm	10.236	5.118 (130mm)	5,000	8,000
	24.313.201	Chip Fan 3/4" x 330mm	12.992	6.535 (166mm)	5,000	8,000
Repair Kits	24.303.206	Chip Fan Repair Kit 160				
	24.303.207	Chip Fan Repair Kit 260	—	—	—	—
	24.303.205	Chip Fan Repair Kit 330				
Springs	24.303.210	Replacement Springs (10/pack)	—	—	—	—

**Operating Instructions**

- Clean-Tec fans should only be used in enclosed machining centers
- Clean-Tec fans equipped with either a ø.750 or ø20mm straight shank should be securely mounted in either a collet chuck or end mill holder
- Rotational direction clockwise only
- Optimum feed rate for cleaning is between 120-390 in/min
- Distance from workpiece should be between 4"-6"
- Upon rotational start-up, program an initial speed of 2,000 RPM (max) before obtaining running speed to reduce the possibility of blade failure due to excessive centrifugal force
- Please note the clearance dimensions with Clean-Tec fans for optimum performance and to avoid collisions upon cycle starts and stops

## T-Slot Clean

Improve your work safety environment and efficiency of table cleaning. Save the time required to clean T-slots packed with chips. Coolant quickly removes heated swarf and helps to prevent thermal displacement of the machine.

- Quick removal of chips from a machine
- Faster table cleaning → A reduction of clean-up time
- Volume control of heated chips → Better machining precision
- Three sizes of T-slot widths are available to fit your machine table



T-slots packed with difficult to remove chips

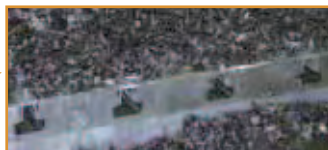

T-slots protected & clear by T-Slot Clean



Removal pin for easy removal

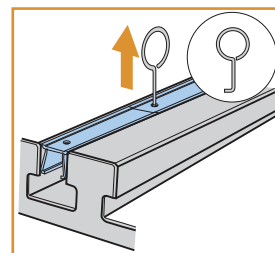
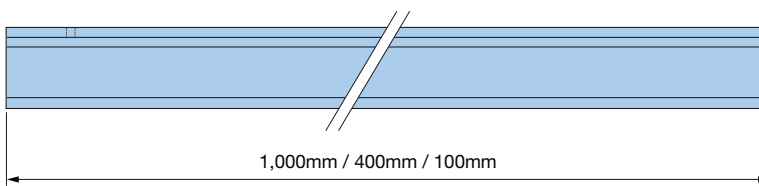
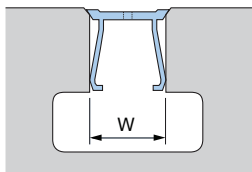

### Standard Set

Type	Catalog Number	Width W	Contents
Metric	TS14-S	14mm	400mm x 4 pcs. 100mm x 4 pcs.
	TS18-S	18mm	
	TS22-S	22mm	

- If necessary, cut to the length that you need
- Removal pin is included

### Cost Saving Set

Type	Catalog Number	Width W	Contents
Metric	TS14-10S	14mm	TS14-S x 10 sets
	TS18-10S	18mm	TS18-S x 10 sets
	TS22-10S	22mm	TS22-S x 10 sets

- Contains 10 Standard Sets for cost savings

### Long Set

Type	Catalog Number	Width W	Contents
Metric	TS18-400L-100P	18mm	400mm x 100 pcs.
	TS22-400L-100P	22mm	

### Extra Long Set

Type	Catalog Number	Width W	Contents
Metric	TS18-1000L-10P	18mm	1,000mm x 10 pcs.
	TS22-1000L-10P	22mm	

BIG Kaiser Precision Tooling Inc. is not just accessories. We're boring tools, tool holders, cutting tools, tool presetters, zero-point workholding and so much more. We're BIG-PLUS®, CAT, BT, HSK and BIG CAPTO. We're tightening tolerances, reducing set-up and cycle times, increasing tool life, and enhancing performance while driving down cost. We're delivering high-performance products and ingenuity for shops that demand results.



# **BIG KAISER**®

## **PRECISION TOOLING INC.**

2600 Huntington Blvd, Hoffman Estates, IL 60192  
Phone: 847.228.7660 • Fax: 847.228.0881  
[www.bigkaiser.com](http://www.bigkaiser.com) • [bigkaiser@bigkaiser.com](mailto:bigkaiser@bigkaiser.com)